

# Enterasys® 7100G-Series

7100G-Series Switch

---

## Hardware Installation Guide

**71G21K2L2-48P**

**71G21K2L2-24P24**

**71G11K2L2-48**





**Electrical Hazard:** Only qualified personnel should perform installation procedures.

**Riesgo Electrico:** Solamente personal calificado debe realizar procedimientos de instalacion.

**Elektrischer Gefahrenhinweis:** Installationen sollten nur durch ausgebildetes und qualifiziertes Personal vorgenommen werden.

**Risques d'électrocution:** Seul un personnel qualifié doit effectuer les procédures d'installation.

## Notice

Enterasys Networks reserves the right to make changes in specifications and other information contained in this document and its web site without prior notice. The reader should in all cases consult Enterasys Networks to determine whether any such changes have been made.

The hardware, firmware, or software described in this document is subject to change without notice.

IN NO EVENT SHALL ENTERASYS NETWORKS BE LIABLE FOR ANY INCIDENTAL, INDIRECT, SPECIAL, OR CONSEQUENTIAL DAMAGES WHATSOEVER (INCLUDING BUT NOT LIMITED TO LOST PROFITS) ARISING OUT OF OR RELATED TO THIS DOCUMENT, WEB SITE, OR THE INFORMATION CONTAINED IN THEM, EVEN IF ENTERASYS NETWORKS HAS BEEN ADVISED OF, KNEW OF, OR SHOULD HAVE KNOWN OF, THE POSSIBILITY OF SUCH DAMAGES.

Enterasys Networks, Inc.  
9 Northeastern Boulevard  
Salem, NH 03079

© 2013 Enterasys Networks, Inc. All rights reserved.

Part Number: 9034795 December 2013

ENTERASYS, ENTERASYS NETWORKS, ENTERASYS SECURE NETWORKS, NETSIGHT, ENTERASYS NETSIGHT, and any logos associated therewith, are trademarks or registered trademarks of Enterasys Networks, Inc., in the United States and/or other countries. For a complete list of Enterasys trademarks, see <http://www.enterasys.com/company/trademarks.aspx>.

All other product names mentioned in this manual may be trademarks or registered trademarks of their respective companies.

**Documentation URL:** <https://extranet.enterasys.com/downloads/>

## Regulatory Compliance Information

### Federal Communications Commission (FCC) Notice

This device complies with Part 15 of the FCC rules. Operation is subject to the following two conditions: (1) this device may not cause harmful interference, and (2) this device must accept any interference received, including interference that may cause undesired operation.

**NOTE:** This equipment has been tested and found to comply with the limits for a class A digital device, pursuant to Part 15 of the FCC rules. These limits are designed to provide reasonable protection against harmful interference when the equipment is operated in a commercial environment. This equipment uses, generates, and can radiate radio frequency energy and if not installed in accordance with the operator's manual, may cause harmful interference to radio communications. Operation of this equipment in a residential area is likely to cause interference in which case the user will be required to correct the interference at his own expense.

**WARNING:** Changes or modifications made to this device which are not expressly approved by the party responsible for compliance could void the user's authority to operate the equipment.

### Industry Canada Notice

This digital apparatus does not exceed the class A limits for radio noise emissions from digital apparatus set out in the Radio Interference Regulations of the Canadian Department of Communications.

Le présent appareil numérique n'émet pas de bruits radioélectriques dépassant les limites applicables aux appareils numériques de la class A prescrites dans le Règlement sur le brouillage radioélectrique édicté par le ministère des Communications du Canada.

### Class A ITE Notice

**WARNING:** This is a Class A product. In a domestic environment this product may cause radio interference in which case the user may be required to take adequate measures.

### Clase A. Aviso de ITE

**ADVERTENCIA:** Este es un producto de Clase A. En un ambiente doméstico este producto puede causar interferencia de radio en cuyo caso puede ser requerido tomar medidas adecuadas.

### Klasse A ITE Anmerkung

**WARNHINWEIS:** Dieses Produkt zählt zur Klasse A (Industriebereich). In Wohnbereichen kann es hierdurch zu Funkstörungen kommen, daher sollten angemessene Vorkehrungen zum Schutz getroffen werden.

### VCCI Notice

This is a class A product based on the standard of the Voluntary Control Council for Interference by Information Technology Equipment (VCCI). If this equipment is used in a domestic environment, radio disturbance may arise. When such trouble occurs, the user may be required to take corrective actions.

この装置は、情報処理装置等電波障害自主規制協議会（VCCI）の基準に基づくクラスA情報技術装置です。この装置を家庭環境で使用すると電波妨害を引き起こすことがあります。この場合には使用者が適切な対策を講ずるよう要求されることがあります。

## BSMI EMC Statement — Taiwan

This is a class A product. In a domestic environment this product may cause radio interference in which case the user may be required to take adequate measures.

警告使用者：

這是甲類的資訊產品，在居住的環境中使用時，可能會造成射頻干擾，在這種情況下，使用者會被要求採取某些適當的對策。

## AS/NZS CISPR 22



## Hazardous Substances

This product complies with the requirements of Directive 2011/65/EU of the European Parliament and of the Council of 8 June 2011 on the restriction of the use of certain hazardous substances in electrical and electronic equipment .

## European Waste Electrical and Electronic Equipment (WEEE) Notice

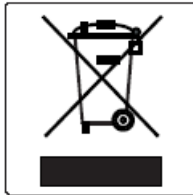

In accordance with Directive 2011/65/EU of the European Parliament on waste electrical and electronic equipment (WEEE):

1. The symbol above indicates that separate collection of electrical and electronic equipment is required and that this product was placed on the European market after August 13, 2005, the date of enforcement for Directive 2011/65/EU.
2. When this product has reached the end of its serviceable life, it cannot be disposed of as unsorted municipal waste. It must be collected and treated separately.
3. It has been determined by the European Parliament that there are potential negative effects on the environment and human health as a result of the presence of hazardous substances in electrical and electronic equipment.
4. It is the users' responsibility to utilize the available collection system to ensure WEEE is properly treated. For information about the available collection system, please contact Enterasys Customer Support at +353 61 705500 (Ireland).

## Battery Notice

This product contains a battery used to maintain product information. If the battery should need replacement it must be replaced by Service Personnel. Please contact Technical Support for assistance.



**Caution:** There is an explosion risk if you replace the battery with the incorrect type. Dispose of expended battery in accordance with local disposal regulations.

**Precaución:** Hay riesgo de explosión si la batería se reemplaza con el tipo incorrecto. Deshágase de las baterías gastadas de conformidad con las regulaciones de eliminación local.

## 产品说明书附件 Supplement to Product Instructions

部件名称 (Parts)	有毒有害物质或元素 (Hazardous Substance)					
	铅 (Pb)	汞 (Hg)	镉 (Cd)	六价铬 (Cr <sup>6+</sup> )	多溴联苯 (PBB)	多溴二苯醚 (PBDE)
金属部件 (Metal Parts)	×	○	○	×	○	○
电路模块 (Circuit Modules)	×	○	○	×	○	○
电缆及电缆组件 (Cables & Cable Assemblies)	×	○	○	×	○	○
塑料和聚合物部件 (Plastic and Polymeric parts)	○	○	○	○	○	×
电路开关 (Circuit Breakers)	○	○	×	×	○	○

○： 表示该有毒有害物质在该部件所有均质材料中的含量均在 SJ/T 11363-2006 标准规定的限量要求以下。  
Indicates that the concentration of the hazardous substance in all homogeneous materials in the parts is below the relevant threshold of the SJ/T 11363-2006 standard.

×： 表示该有毒有害物质至少在该部件的某一均质材料中的含量超出SJ/T 11363-2006 标准规定的限量要求。  
Indicates that the concentration of the hazardous substance of at least one of all homogeneous materials in the parts is above the relevant threshold of the SJ/T 11363-2006 standard.

对销售之日的所售产品, 本表显示,  
凯创供应链的电子产品信息产品可能包含这些物质。注意: 在所售产品中可能会也可能不会含有所有所列的部件。  
This table shows where these substances may be found in the supply chain of Enterasys' electronic information products, as of the date of sale of the enclosed product. Note that some of the component types listed above may or may not be a part of the enclosed product.

除非另外特别的标注, 此标志为针对所涉及产品的环保使用期标志。某些零部件会有一个不同的环保使用期(例如, 电池单元模块)贴在其产品上。  
此环保使用期限只适用于产品是在产品手册中所规定的条件下工作。  
The Environmentally Friendly Use Period (EFUP) for all enclosed products and their parts are per the symbol shown here, unless otherwise marked. Certain parts may have a different EFUP (for example, battery modules) and so are marked to reflect such. The Environmentally Friendly Use Period is valid only when the product is operated under the conditions defined in the product manual.



## Safety Information Class 1 Laser Transceivers

**The single mode interface modules use Class 1 laser transceivers.  
Read the following safety information before installing or operating these modules.**

The Class 1 laser transceivers use an optical feedback loop to maintain Class 1 operation limits. This control loop eliminates the need for maintenance checks or adjustments. The output is factory set, and does not allow any user adjustment. Class 1 Laser transceivers comply with the following safety standards:

- 21 CFR 1040.10 and 1040.11 U.S. Department of Health and Human Services (FDA).
- IEC Publication 825 (International Electrotechnical Commission).
- CENELEC EN 60825 (European Committee for Electrotechnical Standardization).

When operating within their performance limitations, laser transceiver output meets the Class 1 accessible emission limit of all three standards. Class 1 levels of laser radiation are not considered hazardous.

When the connector is in place, all laser radiation remains within the fiber. The maximum amount of radiant power exiting the fiber (under normal conditions) is -12.6 dBm or  $55 \times 10^{-6}$  watts.

Removing the optical connector from the transceiver allows laser radiation to emit directly from the optical port. The maximum radiance from the optical port (under worst case conditions) is  $0.8 \text{ W cm}^{-2}$  or  $8 \times 10^3 \text{ W m}^{-2} \text{ sr}^{-1}$ .

**Do not use optical instruments to view the laser output. The use of optical instruments to view laser output increases eye hazard. When viewing the output optical port, power must be removed from the network adapter.**

### Safety Compliance

#### Warning: Fiber Optic Port Safety

**CLASS I  
LASER DEVICE**

When using a fiber optic media expansion module, never look at the transmit laser while it is powered on. Also, never look directly at the fiber TX port and fiber cable ends when they are powered on.

#### Avertissement: Ports pour fibres optiques - sécurité sur le plan optique

**DISPOSITIF LASER  
DE CLASSE I**

Ne regardez jamais le laser tant qu'il est sous tension. Ne regardez jamais directement le port TX (Transmission) à fibres optiques et les embouts de câbles à fibres optiques tant qu'ils sont sous tension.

#### Warnhinweis: Faseroptikanschlüsse - Optische Sicherheit

**LASERGERÄT  
DER KLASSE I**

Niemals ein Übertragungslaser betrachten, während dieses eingeschaltet ist. Niemals direkt auf den Faser-TX-Anschluß und auf die Faserkabelenden schauen, während diese eingeschaltet sind.

## Declaration of Conformity

Application of Council Directive(s): **2004/108/EC**  
**2006/95/EC**

Manufacturer's Name: **Enterasys Networks, Inc.**

Manufacturer's Address: **9 Northeastern Boulevard**  
**Salem, NH 03079**  
**USA**

European Representative Name: **Enterasys Networks Limited**

European Representative Address: **Nexus House, Newbury Business Park**  
**London Road, Newbury**  
**Berkshire RG14 2PZ, England**

Conformance to Directive(s)/Product Standards: **EC Directive 2004/108/EC**  
**EN55022:2006**  
**A1:2007**  
**EN 55024:1998**  
**A1:2001**  
**A2:2003**  
**EN 61000-3-2:2006**  
**A1:2009**  
**A2:2009**  
**EN 61000-3-3:2008**  
**EC Directive 2006/95/EC**  
**EN 60950-1:2006**  
**A1:2009**  
**EN 60825-1:2007**  
**EN 60825-2:2004**  
**A1:2007**  
**EC Directive 2011/65/EU**

Equipment Type/Environment: **Information Technology Equipment, for use in a Commercial or Light Industrial Environment.**

The object of the declaration described above is in conformity with Directive 2011/65/EU of the European Parliament and of the Council of 8 June 2011 on the restriction of the use of certain hazardous substances in electrical and electronic equipment.



# Enterasys Networks, Inc. Firmware License Agreement

## BEFORE OPENING OR UTILIZING THE ENCLOSED PRODUCT, CAREFULLY READ THIS LICENSE AGREEMENT.

This document is an agreement (“Agreement”) between the end user (“You”) and Enterasys Networks, Inc., on behalf of itself and its Affiliates (as hereinafter defined) (“Enterasys”) that sets forth Your rights and obligations with respect to the Enterasys software program/firmware (including any accompanying documentation, hardware or media) (“Program”) in the package and prevails over any additional, conflicting or inconsistent terms and conditions appearing on any purchase order or other document submitted by You. “Affiliate” means any person, partnership, corporation, limited liability company, other form of enterprise that directly or indirectly through one or more intermediaries, controls, or is controlled by, or is under common control with the party specified. This Agreement constitutes the entire understanding between the parties, with respect to the subject matter of this Agreement. The Program may be contained in firmware, chips or other media.

BY INSTALLING OR OTHERWISE USING THE PROGRAM, YOU REPRESENT THAT YOU ARE AUTHORIZED TO ACCEPT THESE TERMS ON BEHALF OF THE END USER (IF THE END USER IS AN ENTITY ON WHOSE BEHALF YOU ARE AUTHORIZED TO ACT, “YOU” AND “YOUR” SHALL BE DEEMED TO REFER TO SUCH ENTITY) AND THAT YOU AGREE THAT YOU ARE BOUND BY THE TERMS OF THIS AGREEMENT, WHICH INCLUDES, AMONG OTHER PROVISIONS, THE LICENSE, THE DISCLAIMER OF WARRANTY AND THE LIMITATION OF LIABILITY. IF YOU DO NOT AGREE TO THE TERMS OF THIS AGREEMENT OR ARE NOT AUTHORIZED TO ENTER INTO THIS AGREEMENT, ENTERASYS IS UNWILLING TO LICENSE THE PROGRAM TO YOU AND YOU AGREE TO RETURN THE UNOPENED PRODUCT TO ENTERASYS OR YOUR DEALER, IF ANY, WITHIN TEN (10) DAYS FOLLOWING THE DATE OF RECEIPT FOR A FULL REFUND.

IF YOU HAVE ANY QUESTIONS ABOUT THIS AGREEMENT, CONTACT ENTERASYS NETWORKS, LEGAL DEPARTMENT AT (603) 952-5000.

### You and Enterasys agree as follows:

1. **LICENSE.** You have the non-exclusive and non-transferable right to use only the one (1) copy of the Program provided in this package subject to the terms and conditions of this Agreement.
2. **RESTRICTIONS.** Except as otherwise authorized in writing by Enterasys, You may not, nor may You permit any third party to:
  - (a) Reverse engineer, decompile, disassemble or modify the Program, in whole or in part, including for reasons of error correction or interoperability, except to the extent expressly permitted by applicable law and to the extent the parties shall not be permitted by that applicable law, such rights are expressly excluded. Information necessary to achieve interoperability or correct errors is available from Enterasys upon request and upon payment of Enterasys’ applicable fee.
  - (b) Incorporate the Program in whole or in part, in any other product or create derivative works based on the Program, in whole or in part.
  - (c) Publish, disclose, copy reproduce or transmit the Program, in whole or in part.
  - (d) Assign, sell, license, sublicense, rent, lease, encumber by way of security interest, pledge or otherwise transfer the Program, in whole or in part.
  - (e) Remove any copyright, trademark, proprietary rights, disclaimer or warning notice included on or embedded in any part of the Program.
3. **APPLICABLE LAW.** This Agreement shall be interpreted and governed under the laws and in the state and federal courts of the State of New Hampshire without regard to its conflicts of laws provisions. You accept the personal jurisdiction and venue of the State of New Hampshire courts. None of the 1980 United Nations Convention on the Limitation Period in the International Sale of Goods, and the Uniform Computer Information Transactions Act shall apply to this Agreement.
4. **EXPORT RESTRICTIONS.** You understand that Enterasys and its Affiliates are subject to regulation by agencies of the U.S. Government, including the U.S. Department of Commerce, which prohibit export or diversion of certain technical products to certain countries, unless a license to export the product is obtained from the U.S. Government or an exception from obtaining such license may be relied upon by the exporting party.

If the Program is exported from the United States pursuant to the License Exception CIV under the U.S. Export Administration Regulations, You agree that You are a civil end user of the Program and agree that You will use the Program for civil end uses only and not for military purposes.

If the Program is exported from the United States pursuant to the License Exception TSR under the U.S. Export Administration Regulations, in addition to the restriction on transfer set forth in Section 1 or 2 of this Agreement, You agree not to (i) reexport or release the Program, the source code for the Program or technology to a national of a country in Country Groups D:1 or E:2 (Albania, Armenia, Azerbaijan, Belarus, Cambodia, Cuba, Georgia, Iraq, Kazakhstan, Laos, Libya, Macau, Moldova, Mongolia, North Korea, the People’s Republic of China, Russia, Tajikistan, Turkmenistan, Ukraine, Uzbekistan,

Vietnam, or such other countries as may be designated by the United States Government), (ii) export to Country Groups D:1 or E:2 (as defined herein) the direct product of the Program or the technology, if such foreign produced direct product is subject to national security controls as identified on the U.S. Commerce Control List, or (iii) if the direct product of the technology is a complete plant or any major component of a plant, export to Country Groups D:1 or E:2 the direct product of the plant or a major component thereof, if such foreign produced direct product is subject to national security controls as identified on the U.S. Commerce Control List or is subject to State Department controls under the U.S. Munitions List.

5. **UNITED STATES GOVERNMENT RESTRICTED RIGHTS.** The enclosed Program (i) was developed solely at private expense; (ii) contains "restricted computer software" submitted with restricted rights in accordance with section 52.227-19 (a) through (d) of the Commercial Computer Software-Restricted Rights Clause and its successors, and (iii) in all respects is proprietary data belonging to Enterasys and/or its suppliers. For Department of Defense units, the Program is considered commercial computer software in accordance with DFARS section 227.7202-3 and its successors, and use, duplication, or disclosure by the U.S. Government is subject to restrictions set forth herein.

6. **DISCLAIMER OF WARRANTY.** EXCEPT FOR THOSE WARRANTIES EXPRESSLY PROVIDED TO YOU IN WRITING BY ENTERASYS, ENTERASYS DISCLAIMS ALL WARRANTIES, EITHER EXPRESS OR IMPLIED, INCLUDING BUT NOT LIMITED TO IMPLIED WARRANTIES OF MERCHANTABILITY, SATISFACTORY QUALITY, FITNESS FOR A PARTICULAR PURPOSE, TITLE AND NON-INFRINGEMENT WITH RESPECT TO THE PROGRAM. IF IMPLIED WARRANTIES MAY NOT BE DISCLAIMED BY APPLICABLE LAW, THEN ANY IMPLIED WARRANTIES ARE LIMITED IN DURATION TO THIRTY (30) DAYS AFTER DELIVERY OF THE PROGRAM TO YOU.

7. **LIMITATION OF LIABILITY.** IN NO EVENT SHALL ENTERASYS OR ITS SUPPLIERS BE LIABLE FOR ANY DAMAGES WHATSOEVER (INCLUDING, WITHOUT LIMITATION, DAMAGES FOR LOSS OF BUSINESS, PROFITS, BUSINESS INTERRUPTION, LOSS OF BUSINESS INFORMATION, SPECIAL, INCIDENTAL, CONSEQUENTIAL, OR RELIANCE DAMAGES, OR OTHER LOSS) ARISING OUT OF THE USE OR INABILITY TO USE THE PROGRAM, EVEN IF ENTERASYS HAS BEEN ADVISED OF THE POSSIBILITY OF SUCH DAMAGES. THIS FOREGOING LIMITATION SHALL APPLY REGARDLESS OF THE CAUSE OF ACTION UNDER WHICH DAMAGES ARE SOUGHT.

THE CUMULATIVE LIABILITY OF ENTERASYS TO YOU FOR ALL CLAIMS RELATING TO THE PROGRAM, IN CONTRACT, TORT OR OTHERWISE, SHALL NOT EXCEED THE TOTAL AMOUNT OF FEES PAID TO ENTERASYS BY YOU FOR THE RIGHTS GRANTED HEREIN.

8. **AUDIT RIGHTS.** You hereby acknowledge that the intellectual property rights associated with the Program are of critical value to Enterasys, and, accordingly, You hereby agree to maintain complete books, records and accounts showing (i) license fees due and paid, and (ii) the use, copying and deployment of the Program. You also grant to Enterasys and its authorized representatives, upon reasonable notice, the right to audit and examine during Your normal business hours, Your books, records, accounts and hardware devices upon which the Program may be deployed to verify compliance with this Agreement, including the verification of the license fees due and paid Enterasys and the use, copying and deployment of the Program. Enterasys' right of examination shall be exercised reasonably, in good faith and in a manner calculated to not unreasonably interfere with Your business. In the event such audit discovers non-compliance with this Agreement, including copies of the Program made, used or deployed in breach of this Agreement, You shall promptly pay to Enterasys the appropriate license fees. Enterasys reserves the right, to be exercised in its sole discretion and without prior notice, to terminate this license, effective immediately, for failure to comply with this Agreement. Upon any such termination, You shall immediately cease all use of the Program and shall return to Enterasys the Program and all copies of the Program.

9. **OWNERSHIP.** This is a license agreement and not an agreement for sale. You acknowledge and agree that the Program constitutes trade secrets and/or copyrighted material of Enterasys and/or its suppliers. You agree to implement reasonable security measures to protect such trade secrets and copyrighted material. All right, title and interest in and to the Program shall remain with Enterasys and/or its suppliers. All rights not specifically granted to You shall be reserved to Enterasys.

10. **ENFORCEMENT.** You acknowledge and agree that any breach of Sections 2, 4, or 9 of this Agreement by You may cause Enterasys irreparable damage for which recovery of money damages would be inadequate, and that Enterasys may be entitled to seek timely injunctive relief to protect Enterasys' rights under this Agreement in addition to any and all remedies available at law.

11. **ASSIGNMENT.** You may not assign, transfer or sublicense this Agreement or any of Your rights or obligations under this Agreement, except that You may assign this Agreement to any person or entity which acquires substantially all of Your stock assets. Enterasys may assign this Agreement in its sole discretion. This Agreement shall be binding upon and inure to the benefit of the parties, their legal representatives, permitted transferees, successors and assigns as permitted by this Agreement. Any attempted assignment, transfer or sublicense in violation of the terms of this Agreement shall be void and a breach of this Agreement.

12. **WAIVER.** A waiver by Enterasys of a breach of any of the terms and conditions of this Agreement must be in writing and will not be construed as a waiver of any subsequent breach of such term or condition. Enterasys' failure to enforce a term upon Your breach of such term shall not be construed as a waiver of Your breach or prevent enforcement on any other occasion.

13. **SEVERABILITY.** In the event any provision of this Agreement is found to be invalid, illegal or unenforceable, the validity, legality and enforceability of any of the remaining provisions shall not in any way be affected or impaired thereby, and that provision shall be reformed, construed and enforced to the maximum extent permissible. Any such invalidity, illegality, or unenforceability in any jurisdiction shall not invalidate or render illegal or unenforceable such provision in any other jurisdiction.

14. **TERMINATION.** Enterasys may terminate this Agreement immediately upon Your breach of any of the terms and conditions of this Agreement. Upon any such termination, You shall immediately cease all use of the Program and shall return to Enterasys the Program and all copies of the Program.



---

# Contents

## About This Guide

Who Should Use This Guide .....	xv
How to Use This Guide .....	xv
Related Documents .....	xvi
Typographical Conventions .....	xvi
Getting Help .....	xvii

## Chapter 1: Introduction

71G21K2L2-48P .....	1-1
71G21K2L2-24P24 .....	1-2
71G11K2L2-48 .....	1-2
AC Power Supplies .....	1-3
Fans .....	1-3
Micro-USB Port .....	1-3
Management .....	1-3
Virtual Switch Bonding .....	1-4

## Chapter 2: Installation

Required Tools .....	2-1
Installation Site Requirements .....	2-2
Unpacking the 7100G-Series Switch .....	2-2
Mounting the 7100G-Series Switch .....	2-3
Power Supply Air Flow and Switch Fan Module Air Flow .....	2-4
Reversing the Fan Module Air Flow .....	2-5
Removing the Fan Module .....	2-5
Reversing the Fan Unit.....	2-6
Reinstall the Fan Module.....	2-6
Rack Mount Ear Positioning .....	2-7
Flush-Mount Switch I/O Ports Facing Front Configuration .....	2-7
Mid-Mount Switch I/O Ports Facing Front Configuration .....	2-8
Mid-Mount Power Supply Facing Front Configuration.....	2-9
Securing the 7100G-Series Switch to the Rack .....	2-10
Flat Surface Installation .....	2-12
Unpacking the Power Supplies .....	2-12
Installing the Power Supplies .....	2-12
Powering Up the 7100G-Series Switch .....	2-14
Installing the Power Cord Retention Clip Assembly .....	2-14
Connecting to the Network .....	2-15
Connecting Category 5E Ethernet Cables to the BASE-T Ports .....	2-15
Connecting Pluggable Transceivers to the SFP+ and QSFP+ Ports .....	2-16
Multiple 7100G-Series Chassis Stacking (Virtual Switch Bonding) .....	2-18
Connecting to the COM Port for Local Management .....	2-19
What Is Needed .....	2-19
Connecting to a PC or Laptop .....	2-19
Connecting to a VT Series Terminal .....	2-19
Adapter Wiring and Signal Assignments .....	2-20
Completing the Installation .....	2-21

## Chapter 3: Troubleshooting

LEDs .....	3-1
------------	-----

Port LEDs .....	3-1
System LEDs .....	3-4
Power Supply LED .....	3-5
Troubleshooting Checklist .....	3-6
Replacing the 7100G-Series Fan Module .....	3-8
Removing a Power Supply .....	3-9
Using the OFFLINE/RESET Button .....	3-10
Recommended Shutdown Procedure Using OFFLINE/RESET Button .....	3-10
Last Resort Shutdown Procedure Using OFFLINE/RESET Button .....	3-11

## Appendix A: Specifications

7100G-Series Switch Specifications .....	A-1
Pluggable Transceiver Specifications .....	A-2
COM Port Pinout Assignments .....	A-2
Regulatory Compliance .....	A-3

## Appendix B: Clearing the Persistent Storage or System Password

Clearing Persistent Storage or Password using the Boot Loader Method .....	B-1
Clearing System Storage or Password Using the Dip Switch Method .....	B-2
Required Tools .....	B-3
About the Mode Switches .....	B-3
Setting the Mode Switches .....	B-4

## Appendix C: Optional Rack Mount Rail Kit Installation

Required Tools .....	C-1
Contents of Mounting Kit .....	C-2
Installation Site Requirements .....	C-2
Required Order of Installation .....	C-3
Removing the Rack Mount Ears from the 7100G-Series Chassis .....	C-3
Installing the Adapter Plates .....	C-3
4-Post Rack Mount Installation .....	C-5
Rack Mount Rail with Attached Extension Assembly Installation .....	C-6
Chassis to Rail Assembly Installation .....	C-6
2-Post Rack Mount Installation .....	C-7
Pre-Installation Tasks .....	C-8
Rack Mount Rail Assembly Extension Removal.....	C-8
Mid-Bracket to Rail Assembly.....	C-9
Securing the Rail Assembly for a 2-Post Flush Mount Configuration .....	C-11
Securing the Rail Assembly for a 2-Post Mid-Mount Configuration .....	C-12
Securing the 7100G-Series Chassis to the Rack .....	C-13

## Appendix D: About PoE (Power over Ethernet)

Overview .....	D-1
Proprietary PD Detection .....	D-1
PoE Port Status LEDs .....	D-2
Allocation of PoE Power to Devices .....	D-2
Power Distribution Upon Power Supply Removal or Addition .....	D-2
Management of PoE Power to PDs .....	D-3

## Appendix E: Environmental Guidelines

Temperature and Humidity Guidelines .....	E-1
Operating Temperatures .....	E-1
Inlet Air Temperature Measurement .....	E-1
Cooling Air .....	E-1

Power Conditioning .....	E-1
Airflow Concerns for Closed Racks .....	E-2
Airflow Concerns for Open Racks .....	E-3
Dust Mitigation and Prevention .....	E-5
Airborne Chemicals and Prevention .....	E-6

## Figures

1-1 71G21K2L2-48P I/O Port Panel .....	1-1
1-2 71G21K2L2-24P24 I/O Port Panel .....	1-2
1-3 71G11K2L2-48 I/O Port Panel.....	1-2
2-1 7100G-Series Switch Rack Configurations .....	2-3
2-2 Removing the Switch Fan Module.....	2-5
2-3 Reversing the Fan Module Air Flow .....	2-6
2-4 Flush Mount Switch I/O Ports Front Configuration .....	2-8
2-5 Mid-Mount Switch I/O Ports Facing Front Configuration .....	2-9
2-6 Mid-Mount Power Supply Front Configuration.....	2-10
2-7 Securing the 7100G-Series Switch to the Rack in a Flush Mount Configuration .....	2-11
2-8 Securing the 7100G-Series Switch to the Rack in a Mid-Mount Configuration .....	2-11
2-9 Installing a Power Supply .....	2-13
2-10 Removing the Power Supply Bay Coverplate.....	2-14
2-11 Installing the Power Cord Clip Assembly in the Power Supply.....	2-15
2-12 7100G-Series Switch Ground Receptacle.....	2-17
3-1 SFP+ and QSFP+ Port LEDs.....	3-2
3-2 1000 BASE-T (RJ45) Port LEDs.....	3-3
3-3 7100G-Series System LEDs.....	3-4
3-4 Removing the Fan Module .....	3-8
3-5 Removing the Power Supply .....	3-9
3-6 OFFLINE/RESET Button .....	3-10
B-1 Mode Switch Location .....	B-4
C-1 Removing the 7100G-Series Chassis Rack Mount Ears.....	C-3
C-2 Installing the Adapter Plates.....	C-4
C-3 Four Post Rack Supported Configurations.....	C-5
C-4 Installing the Rack Mount Rail with Extension Assemblies .....	C-6
C-5 Installing the Chassis on to the Rack Mount Rail Assembly.....	C-7
C-6 Two Post Rack Supported Configurations.....	C-8
C-7 Removing the Extension from the Rack Mount Rail Assembly .....	C-9
C-8 Securing Mid-Bracket to Rail 3 Inch Flush Mount .....	C-10
C-9 Securing Mid-Bracket to Rail 7.25 Inch Flush Mount or Mid-Mount .....	C-11
C-10 Securing a Flush Mount Rail Assembly.....	C-12
C-11 Securing Mid-Mount Rail Assembly.....	C-13
C-12 Securing the 7100G-Series Chassis to the Rack .....	C-14
E-1 Closed Rack Ideal Configuration .....	E-2
E-2 Open Rack Ideal Configuration .....	E-3
E-3 Non-ideal Open Rack Configuration.....	E-4
E-4 Mitigated Non-ideal Open Rack Configuration .....	E-4
E-5 Another Mitigated Non-ideal Open Rack Configuration.....	E-5

## Tables

2-1 Contents of 7100G-Series Switch .....	2-2
2-2 Switch Fan Module Air Flow Direction.....	2-4
2-3 71A-PS-A/B Power Supply Air Flow Based on Model Number .....	2-4
2-4 Contents of 7100G-Series Power Supply Carton .....	2-12
3-1 SFP+ Port LEDs .....	3-2
3-2 QSFP+ Port LEDs .....	3-3
3-3 BASE-T Port LEDs .....	3-3

3-4	System LEDs .....	3-4
3-5	CPU LED in Virtual Switch Bonding (VSB) Configuration .....	3-5
3-6	Power Supply LED Status Definitions .....	3-6
3-7	Troubleshooting Checklist .....	3-6
A-1	7100-Series Switch Ports .....	A-1
A-2	Specifications .....	A-2
A-3	COM Port Pin Assignments .....	A-2
A-4	Compliance Standards .....	A-3
C-1	Contents of 71A-RACK-U .....	C-2
D-1	Powered Device Classifications .....	D-1
D-2	PoE LED Status .....	D-2
E-1	Airborne Dust Specification for Enterasys Equipment — Airborne Dust Maximum Values .....	E-6



---

# About This Guide

This guide provides an overview, installation, troubleshooting, and optional rack mount rail kit installation instructions, and specifications for the Enterasys® 7100G-Series switch models:

- 71G21K2L2-48P
- 71G21K2L2-24P24
- 71G11K2L2-48

## Who Should Use This Guide



**Electrical Hazard:** Only qualified personnel should install or service this unit.

**Riesgo Electrico:** Nada mas personal capacitado debe de instalar o darle servicio a esta unida.

**Elektrischer Gefahrenhinweis:** Installationen oder Servicearbeiten sollten nur durch ausgebildetes und qualifiziertes Personal vorgenommen werden.

**Risques d'électrocution:** Seul un personnel qualifié doit effectuer les procédures d'installation.

This guide is intended for a network administrator who is responsible for installing and setting up the 7100G-Series switch.

## How to Use This Guide

Read through this guide completely to familiarize yourself with its contents and to gain an understanding of the features and capabilities of the 7100G-Series switch. A general working knowledge of data communications networks is helpful when setting up the 7100G-Series switch.

This preface provides the following:

- An overview of this guide and the 7100G-Series manual set
- A brief summary of each chapter
- Definitions of the conventions used in this document
- Instructions regarding how to obtain technical support from Enterasys Networks.

To locate information about various subjects in this guide, refer to the following table.

For...	Refer to...
An overview of the 7100G-Series switch and its features.	<a href="#">Chapter 1, Introduction</a>
Instructions for installing the 7100G-Series switch hardware and connecting the 7100G-Series switch to the network.	<a href="#">Chapter 2, Installation</a>
Information on port, system, and power supply LEDs; how to replace a 7100G-Series fan module and power supply; and how to restart or shut down the 7100G-Series switch using the OFFLINE/RESET button.	<a href="#">Chapter 3, Troubleshooting</a>
Specifications, environmental requirements, and physical properties of the 7100G-Series switch.	<a href="#">Appendix A, Specifications</a>

For...	Refer to...
Details on how to clear either the persistent storage or the system password as troubleshooting tools.	<a href="#">Appendix B, Clearing the Persistent Storage or System Password</a>
Details on how to install the optional rack mount kit.	<a href="#">Appendix C, Optional Rack Mount Rail Kit Installation</a>
Details environmental guidelines such as operating temperature, air flow, inlet temperature, and dust mitigation and prevention.	<a href="#">Appendix E, Environmental Guidelines</a>

## Related Documents

The *Enterasys 7100-Series Configuration Guide* and *Enterasys 7100-Series CLI Reference Guide* provide information on how to use the CLI to set up and manage the 7100G-Series switch.



The *Enterasys 7100-Series Quick Reference* provides an overview of key considerations when installing the 7100G-Series switch.

These manuals can be obtained from the World Wide Web in Adobe Acrobat Portable Document Format (PDF) at the following site:

<https://extranet.enterasys.com/downloads/>

## Typographical Conventions

The following typographical conventions and icons are used in this document.

<b>blue type</b>	Indicates a hypertext link. When reading this document online, click the text in blue to go to the referenced figure, table, or section.
Lowercase x	Indicates the general use of an alphanumeric character.
	<b>Note:</b> Calls the reader's attention to any item of information that may be of special importance.
	<b>Caution:</b> Contains information essential to avoid damage to the equipment. <b>Precaución:</b> Contiene información esencial para prevenir dañar el equipo. <b>Achtung:</b> Verweist auf wichtige Informationen zum Schutz gegen Beschädigungen.
	<b>Warning:</b> Warns against an action that could result in personal injury or death. <b>Advertencia:</b> Advierte contra una acción que pudiera resultar en lesión corporal o la muerte. <b>Warnhinweis:</b> Warnung vor Handlungen, die zu Verletzung von Personen oder gar Todesfällen führen können! <b>Avertissement:</b> Met en garde contre un geste qui pourrait entraîner des blessures ou la mort.



**Electrical Hazard:** Warns against an action that could result in personal injury or death.

**Riesgo Electrico:** Advierte contra una acción que pudiera resultar en lesión corporal o la muerte debido a un riesgo eléctrico.

**Elektrischer Gefahrenhinweis:** Warnung vor sämtlichen Handlungen, die zu Verletzung von Personen oder Todesfällen – hervorgerufen durch elektrische Spannung – führen können!

**Risques d'électrocution:** Met en garde contre un geste qui pourrait entraîner des blessures ou la mort à la suite d'une électrocution.

## Getting Help

For additional support related to the 7100G-Series switch or this document, contact Enterasys Networks using one of the following methods:

World Wide Web	<a href="http://www.enterasys.com/support">www.enterasys.com/support</a>
Phone	1-800-872-8440 (toll-free in U.S. and Canada) or 1-603-952-5000  For the Enterasys Networks Support toll-free number in your country: <a href="http://www.enterasys.com/support">www.enterasys.com/support</a>
Email	<a href="mailto:support@enterasys.com">support@enterasys.com</a>  To expedite your message, please type <b>[7100-Series]</b> in the subject line.

**Before contacting Enterasys Networks for technical support, have the following data ready:**

- Your Enterasys Networks service contract number
- A description of the failure
- A description of any action(s) already taken to resolve the problem (for example, changing mode switches or rebooting the unit)
- The serial and revision numbers of all involved Enterasys Networks products in the network
- A description of your network environment (such as layout, cable type, other relevant environmental information)
- Network load and frame size at the time of trouble (if known)
- The device history (for example, if you have returned the device before, or if this is a recurring problem)
- Any previous Return Material Authorization (RMA) numbers



## Introduction

This chapter provides an overview of the capabilities of the Enterasys® 7100G-Series models:

- [71G21K2L2-48P](#)
- [71G21K2L2-24P24](#)
- [71G11K2L2-48](#)

For information about firmware features of the 7100G-Series switch and how to configure them, refer to the *Enterasys 7100-Series Configuration Guide*.

### 71G21K2L2-48P

The 71G21K2L2-48P has forty-eight 10/100/1000 PoE (.at+ .af capable) RJ45 ports, two 1/10Gb SFP+ ports, and two 10/40Gb QSFP+ ports, as shown in [Figure 1-1](#).

**Figure 1-1 71G21K2L2-48P I/O Port Panel**

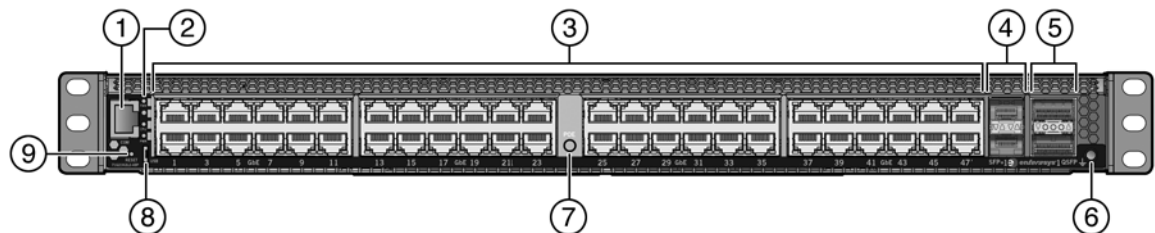

- |   |   |   |                        |
|---|---|---|------------------------|
| 1 | COM port                                      | 6 | Ground receptacle      |
| 2 | System LEDs                                   | 7 | PoE LED button         |
| 3 | 10/100/1000 PoE (.at+ .af capable) RJ45 ports | 8 | Micro-USB port         |
| 4 | 1/10Gb SFP+ ports                             | 9 | OFFLINE/RESTART button |
| 5 | 10/40Gb QSFP+ uplink ports                    |   |                        |

Each of the RJ45 ports operate in full-duplex mode.

The SFP+ and QSFP+ ports support a number of pluggable transceivers. For more information about the transceivers, see the following:

<http://www.enterasys.com/products/transceivers-ds.pdf>

## 71G21K2L2-24P24

The 71G21K2L2-24P24 has twenty-four 100Mb/1Gb SFP ports, twenty-four 10/100/1000 PoE (.at+.af capable) RJ45 ports, two 1/10Gb SFP+ ports and two 10/40Gb QSFP+ ports, as shown in [Figure 1-2](#).

**Figure 1-2 71G21K2L2-24P24 I/O Port Panel**

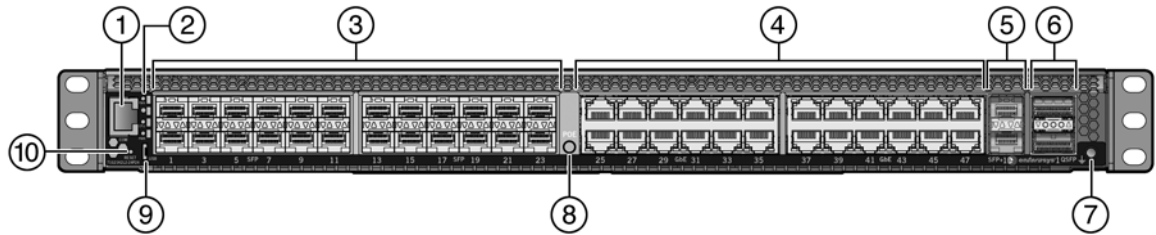

- |   |  |    |                            |
|---|--|----|----------------------------|
| 1 | COM port                                     | 6  | 10/40Gb QSFP+ uplink ports |
| 2 | System LEDs                                  | 7  | Ground receptacle          |
| 3 | 100Mb/1Gb SFP ports                          | 8  | PoE LED button             |
| 4 | 10/100/1000 PoE (.at+.af capable) RJ45 ports | 9  | Micro-USB port             |
| 5 | 1/10Gb SFP+ ports                            | 10 | OFFLINE/RESTART button     |

Each of the 100Mb/1Gb SFP and 10/100/1000 PoE (.at+.af capable) RJ45 ports operate in full-duplex mode.

The SFP+ and QSFP+ ports support a number of pluggable transceivers. For more information about the transceivers, see the following:

<http://www.enterasys.com/products/transceivers-ds.pdf>

## 71G11K2L2-48

The 71G11K2L2-48 has forty-eight 100Mb/1Gb SFP ports, two 1/10Gb SFP+ ports and two 10/40Gb QSFP+ ports, as shown in [Figure 1-3](#).

**Figure 1-3 71G11K2L2-48 I/O Port Panel**

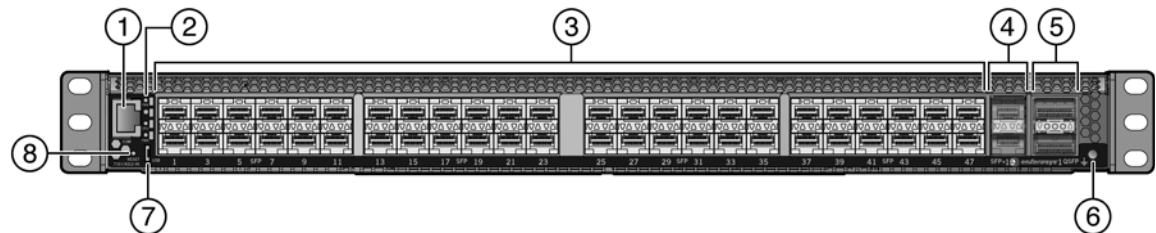

- |   |                        |   |                            |
|---|------------------------|---|----------------------------|
| 1 | COM port               | 5 | 10/40Gb QSFP+ uplink ports |
| 2 | System LEDs            | 6 | Ground receptacle          |
| 3 | 100Mb/1Gb SFP ports    | 7 | Micro-USB port             |
| 4 | 1/10GBASE-T RJ45 ports | 8 | OFFLINE/RESTART button     |

Each of the 100Mb/1Gb SFP ports operate in full-duplex mode.

The SFP+ and QSFP+ ports support a number of pluggable transceivers. For more information about the transceivers, see the following:

<http://www.enterasys.com/products/transceivers-ds.pdf>

## AC Power Supplies

Two 800 watt (PoE) and two 460 watt AC power supply models, which you must order separately, are available for the 7100G-Series switch depending upon the model:

**71G21K2L2-48P and 71G21K2L2-24P24:**

- 71A-POE-A – I/O port side air exhaust
- 71A-POE-B – I/O port side air intake

**71G11K2L2-48:**

- 71A-PS-A – I/O port side air exhaust
- 71A-PS-B – I/O port side air intake

Each power supply option contains a single non-reversible fan. The two power supply options for each 7100-Series model are differentiated by the direction of the power supply fan air flow. Power supply air flow must agree with the air flow direction of the installed fan modules.

The 7100G-Series AC power supplies automatically adjust to the input voltage and frequency, which allows for an input voltage of 100 to 240 Vac, and a frequency between 50 and 60 Hz. See the operating specifications in [Appendix A, Specifications](#). No additional adjustments are necessary. For installations in North America, a 15 Amp power cord is required. See [“Powering Up the 7100G-Series Switch”](#) on page 2-14 for more details.

You can install up to two power supplies in the 7100G-Series chassis. All the power supply needs of the 7100G-Series switch can be met by installing a single power supply. If you choose to use two power supplies, system power redundancy is guaranteed if one supply is lost. Power supplies are hot swappable in redundant power supply mode.

For more information, see [“Installing the Power Supplies”](#) on page 2-12. For information on the power supply LED, see [“Power Supply LED”](#) on page 3-5.

## Fans

The 7100G-Series switch comes with a single installed fan module to cool the system. The direction of the fan module air flow is reversible. By default air flows from the power supply side to the switch I/O port side of the unit. If your 7100G-Series switch configuration requires switch I/O port side to power supply side air flow, see [“Reversing the Fan Module Air Flow”](#) on page 2-5 for details about how to reverse the fan module air flow.

The 7100G-Series fan module is field replaceable. For information on how to replace 7100G-Series fan module, see [“Replacing the 7100G-Series Fan Module”](#) on page 3-8.

## Micro-USB Port

The micro-USB port is provided for local file transfer.

## Management

You can manage the 7100G-Series switch either in-band or out-of-band. In-band remote management is possible using the Enterasys Networks' NetSight<sup>®</sup> management application or the command line interface (CLI) via Telnet. Out-of-band management is provided through the RJ45 COM (Communication) port on the front panel using a PC, a VT terminal, or a VT terminal emulator. For more information, see [“Connecting to the Network”](#) on page 2-15.

## Virtual Switch Bonding

For data center redundancy, you can configure two co-located 7100G-Series chassis to operate as a single logical chassis (a virtual switch bonded chassis) managed by one IP address. Connect the chassis to each other by using the two 40Gb ports on each 7100G-Series chassis.



**Note:** For virtual switch bonding configuration details, see the *Enterasys 7100-Series Configuration Guide*.



# 2

## Installation



**Electrical Hazard:** Only qualified personnel should perform installation procedures.

**Riesgo Electrico:** Solamente personal calificado debe realizar procedimientos de instalacion.

**Elektrischer Gefahrenhinweis:** Installationen sollten nur durch ausgebildetes und qualifiziertes Personal vorgenommen werden.

**Risques d'électrocution:** Seul un personnel qualifié doit effectuer les procédures d'installation.

Follow the order of the sections listed below for correct installation:

For information about...	Refer to page...
<a href="#">Required Tools</a>	<a href="#">2-1</a>
<a href="#">Installation Site Requirements</a>	<a href="#">2-2</a>
<a href="#">Unpacking the 7100G-Series Switch</a>	<a href="#">2-2</a>
<a href="#">Mounting the 7100G-Series Switch</a>	<a href="#">2-3</a>
<a href="#">Unpacking the Power Supplies</a>	<a href="#">2-12</a>
<a href="#">Installing the Power Supplies</a>	<a href="#">2-12</a>
<a href="#">Powering Up the 7100G-Series Switch</a>	<a href="#">2-14</a>
<a href="#">Connecting to the Network</a>	<a href="#">2-15</a>
<a href="#">Multiple 7100G-Series Chassis Stacking (Virtual Switch Bonding)</a>	<a href="#">2-18</a>
<a href="#">Connecting to the COM Port for Local Management</a>	<a href="#">2-19</a>
<a href="#">Completing the Installation</a>	<a href="#">2-21</a>

### Important Notice

Read the Release Notes specific to the firmware image running in the chassis to check for any exceptions to the supported features and operation documented in this guide.

## Required Tools

- ESD wrist strap (included with the 7100G-Series switch)
- Phillips screwdriver

## Installation Site Requirements

You need to have 3–4 inches of clearance on the switch I/O port side of the 7100G-Series switch depending upon the cabling used.

See [Appendix E, Environmental Guidelines](#) for environmental guidelines relating to the 7100G-Series switch installation.

The installation site must be within reach of the network cabling and meet the requirements listed below:

- Appropriate grounded power receptacles must be located within 7 feet of the site.
- A temperature of between 5°C (41°F) and 40°C (104°F) must be maintained at the installation site with fluctuations of less than 10°C (18°F) per hour.



**Caution:** To ensure proper ventilation and prevent overheating, leave a minimum clearance space of 5.1 cm (2.0 in.) at the front and rear of the device.

**Precaución:** Para asegurar una buena ventilación y evitar que el sistema se sobrecaliente, deje un espacio mínimo de 5.1 cm (2 pulgadas) con respecto al anverso y reverso del aparato.

## Unpacking the 7100G-Series Switch

Unpack the 7100G-Series switch as follows:

1. Open the box and remove the packing material protecting the 7100G-Series switch.  
Save the shipping box and materials in the event the unit must be reshipped.
2. Remove and set aside the RJ45-to-DB9 converter, anti-static wrist strap, adhesive feet (for flat surface placement), and power cord retention clips.  
The 7100G-Series switch does not include screws for attaching the 7100G-Series switch to rack posts.
3. Verify the contents of the carton as listed in the [Table 2-1](#).

**Table 2-1 Contents of 7100G-Series Switch**

Item	Number
7100G-Series chassis	1
RJ45 management cable	1
RJ45-to-DB9 converter	1
Anti-static wrist strap	1
Adhesive rubber feet	4
Power cord retention clips	2
7100G-Series Quick Reference	1

4. Inspect the 7100G-Series switch for any signs of physical damage.

If there are any signs of damage, DO NOT install the 7100G-Series switch; instead, contact Enterasys Networks. Refer to [“Getting Help”](#) on page xvii for details.

## Mounting the 7100G-Series Switch



**Note:** The 7100G-Series switch comes with integrated mounting ears that are adequate for most installations. For slide-in mounting, high vibration, or high shock installations, an optional rack mount kit (71A-RACK-U) is available.

To install the 7100G-Series switch in a rack using the 71A-RACK-U optional rack mount kit, follow the pre-installation discussion here including: “[Power Supply Air Flow and Switch Fan Module Air Flow](#)” on page 2-4 and “[Reversing the Fan Module Air Flow](#)” on page 2-5, before proceeding to “[Optional Rack Mount Rail Kit Installation](#)” on page C-1.

You can install a 7100G-Series switch on a flat surface or in a rack. For more information about flat surface installation, see “[Flat Surface Installation](#)” on page 2-12.

There are four possible rack mounting configurations as shown in [Figure 2-1](#), based upon whether:

- The switch I/O ports side or the power supply side of the device face front
- The device is mounted flush with the rack posts or mid-mounted

**Figure 2-1 7100G-Series Switch Rack Configurations**

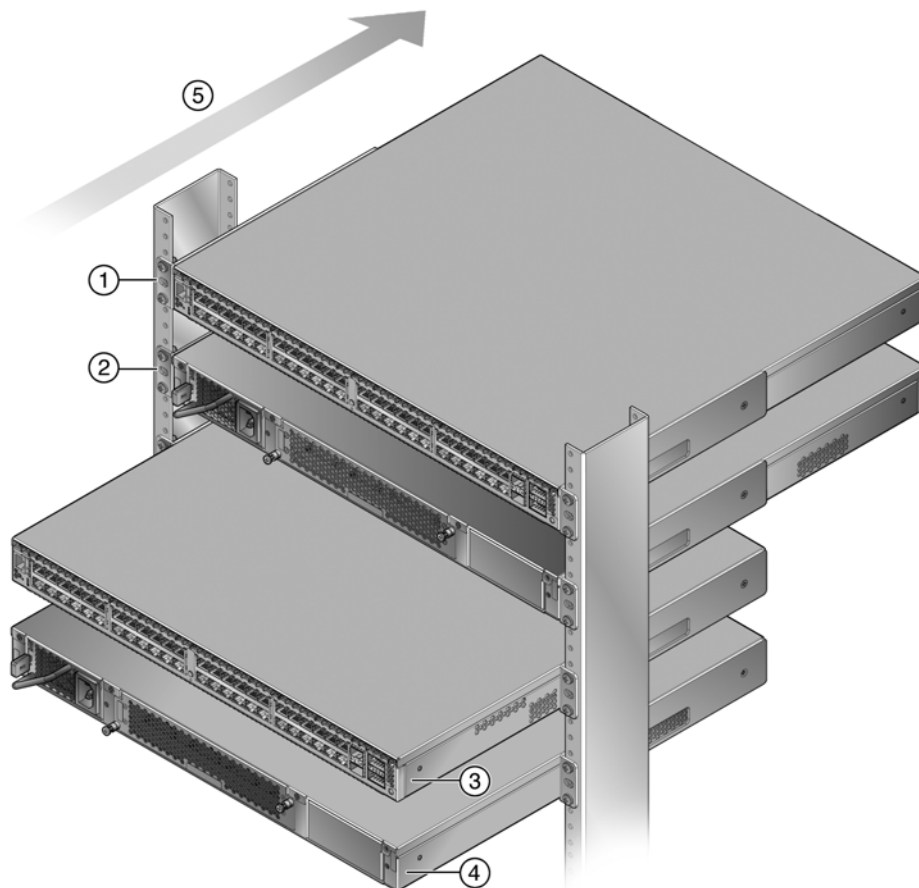

- |   |  |   |  |
|---|--|---|--|
| 1 | Flush mounted with the switch I/O ports facing front (cool air side) | 3 | Mid-mounted with the switch I/O ports facing front |
| 2 | Flush mounted with the power supply facing front (cool air side)     | 4 | Mid-mounting with the power supply facing front    |
|   |  | 5 | Air flow direction                                 |

## Power Supply Air Flow and Switch Fan Module Air Flow

The power supply module has its own fan for cooling the power supply, and the switch fan module has four fans for cooling the switch circuitry. The air flow direction of both the power supply and fan modules must agree in order to properly cool the installed 7100G-Series system. In rack mount configurations it is best practice to mount all devices with a common cool air side and a common exhaust (hot air) side.

On the 7100-Series switch, air flow direction can be from either:

- The power supply side to the switch I/O port side
- The switch I/O port side to the power supply side



**Note:** The power suppl(ies) must be ordered separately from the switch unit, and air flow direction must be specified when ordering them. Power supply air flow direction is fixed and can not be manually changed. If the ordered power supply has an air flow direction that does not work for your rack configuration, you must re-order the power supply that has the correct air flow direction (see [Table 2-3](#)).

The 7100-Series switch is shipped from the factory set up for air flow direction from the power supply side to the switch I/O port side of the device. If your installation requires that air flow direction be from the I/O port side to the power supply side, you will need to reverse the air flow of the switch fan module fans (see [“Reversing the Fan Module Air Flow”](#) on page 2-5). Also, the rack mount flanges (ears) need to be reversed (see [“Rack Mount Ear Positioning”](#) on page 2-7).

Air flow direction of the switch fan modules can be determined by visually inspecting them for whether a white label or a fan blade is visible through the fan screen. Before securing the 7100G-Series switch to the rack or installing the power supply into the 7100G-Series switch, perform a visual verification that both power supply module and switch fan module air flow agree with the intended configuration as defined in [Table 2-2](#) and [Table 2-3](#).

Unpack each power supply you ordered for the 7100G-Series switch (See [“Unpacking the Power Supplies”](#) on page 2-12).

**Table 2-2 Switch Fan Module Air Flow Direction**

Air Flow Direction	Visual Indication
From power supply side to switch I/O port side	Fan blade is visible on fan unit
From switch I/O port side to power supply side	White label is visible on fan unit

For the non-PoE power supplies, the power supply air flow direction can also be verified based upon the power supply manufacturer’s part number located on the power supply bottom label and the airflow direction indicator on the serial number label located on the lower right edge of the regulatory label. The PoE power supplies are labeled with the model number and an air flow arrow indicating unit air flow direction on the power supply bottom label.

**Table 2-3 71A-PS-A/B Power Supply Air Flow Based on Model Number**

Model Number	Mfg. Part Number	Air Flow Direction	Serial Number Label
71A-PS-A	DS460S-3-003	From power supply side to switch I/O port side	

**Table 2-3 71A-PS-A/B Power Supply Air Flow Based on Model Number (continued)**

Model Number	Mfg. Part Number	Air Flow Direction	Serial Number Label
71A-PS-B	DS460S-3-002	From switch I/O port side to power supply side	
71A-POE-A	N/A	From power supply side to switch I/O port side	N/A
71A-POE-B	N/A	From switch I/O port side to power supply side	N/A

## Reversing the Fan Module Air Flow



**Note:** If the 7100-Series switch rack configuration requires the air flow to be from the switch I/O port side to the power supply side, the air flow in the switch fan modules must be reversed for the switch fan module.

## Removing the Fan Module

To remove the switch fan module:

1. Unscrew the two fan module captive screws as shown in [Figure 2-2](#) on page 2-5.
2. Slide the fan module forward until it is unplugged from the device.

**Figure 2-2 Removing the Switch Fan Module**

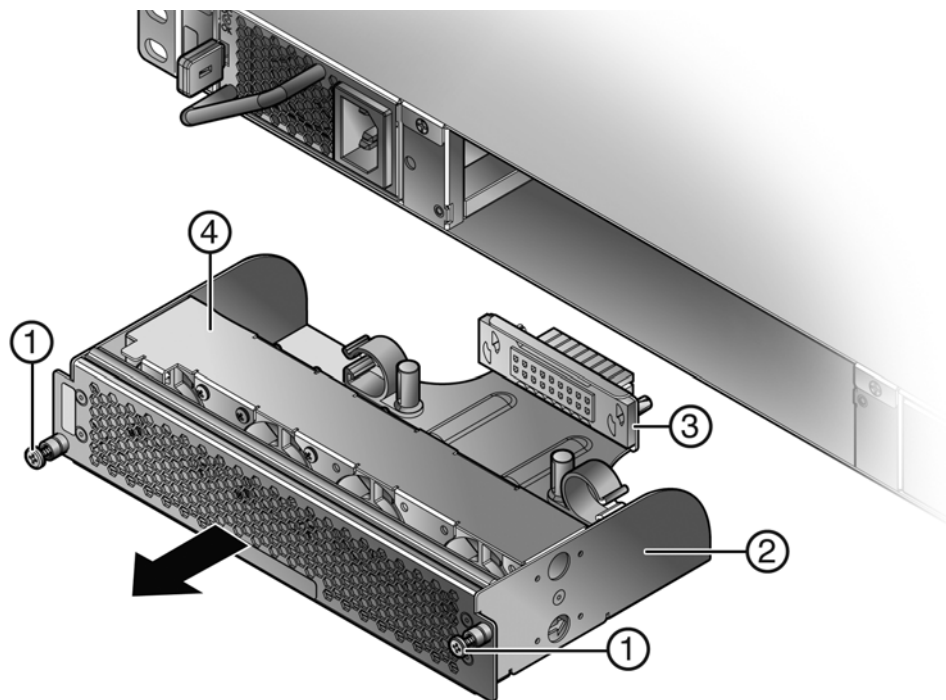

- |                             |                        |
|-----------------------------|------------------------|
| 1 Fan module captive screws | 3 Fan module connector |
| 2 Switch Fan module         | 4 Fan unit metal plate |

## Reversing the Fan Unit

The switch fan module has a single reversible dual fan unit. When the fan unit is properly seated, the air flow indicator arrow is completely visible as shown in callout 1, [Figure 2-3](#) on page 2-6. The air flow indicator arrow points in the direction the fan unit flows air through the fan module.

In the power supply module to switch I/O port (default) air flow configuration, a metal plate covers the fan unit (as shown in [Figure 2-2](#), callout 4, above). When the fan unit is reversed, the fan unit is visible (as shown in callout 3, [Figure 2-3](#)). To reverse the fan module air flow:

1. Hold the module in your hand
2. Apply pressure to the inner edge of the fan unit to rotate the fan unit (thick black arrows in [Figure 2-3](#)).
3. Flip the fan unit 180 degrees until the air flow indicator is again completely visible and pointing towards the fan module screen, as shown in callout 4, [Figure 2-3](#).

**Figure 2-3 Reversing the Fan Module Air Flow**

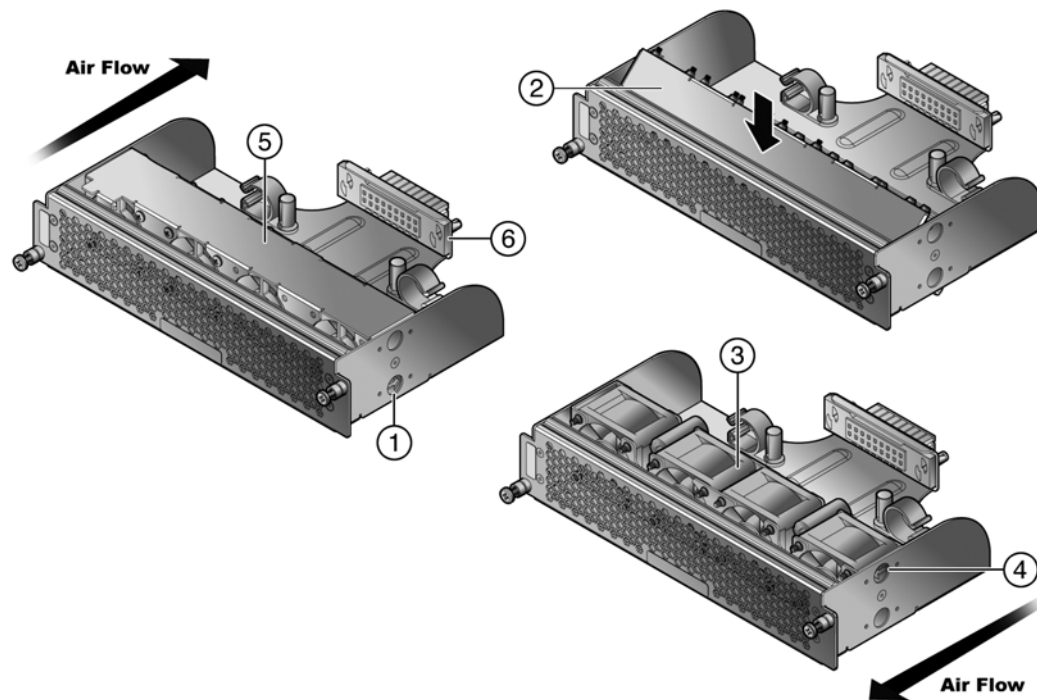

- |   |   |
|---|---|
| 1 Air flow indicator arrow <sup>1</sup> | 4 Air flow indicator arrow <sup>2</sup> |
| 2 Fan unit in mid-reversal              | 5 Fan unit                              |
| 3 Reversed fan unit                     | 6 Fan connector                         |

1. Callout 1 shows air flow from the power supply side to the switch I/O port side of the module.
2. Callout 4 shows air flow from the switch I/O port side of the module to the power supply side.

## Reinstall the Fan Module

To reinstall the fan module:

1. Align the fan module with the fan module opening.
2. Insert the module into the fan module opening, applying enough pressure that the fan module is flush with the device.
3. Secure the two fan module captive screws.

## Rack Mount Ear Positioning

If you are installing the 7100G-Series switch using the 71A-RACK-U optional rack mount kit, proceed to [“Optional Rack Mount Rail Kit Installation”](#) on page C-1.

When shipped from the factory, the 7100G-Series switch has rack mount ears attached to the edge of the side of the switch containing the power supply in a flush mount configuration, as shown in callout 2 of [Figure 2-1](#) on page 2-3. If you are mounting the switch using the factory positioning of the rack mount ears, go to [“Securing the 7100G-Series Switch to the Rack”](#) on page 2-10.

The rack mount ears can be repositioned providing three alternative mounting options.

Alternative mounting options are described in the following sections:

- [“Flush-Mount Switch I/O Ports Facing Front Configuration”](#) on page 2-7
- [“Mid-Mount Switch I/O Ports Facing Front Configuration”](#) on page 2-8
- [“Mid-Mount Power Supply Facing Front Configuration”](#) on page 2-9



**Note:** The side air vents are intentionally covered by the rack mount ears in certain mounting configurations. The 7100G-Series switch cooling design is from front to back, not side to side.

### Flush-Mount Switch I/O Ports Facing Front Configuration

The flush-mount, switch I/O ports facing front, configuration is depicted in callout 1 of [Figure 2-1](#) on page 2-3. This 7100G-Series switch rack mount configuration requires the repositioning of the rack mount ears on both sides of the device.

To reposition the rack mount ears for this configuration:

1. Remove the screw by the three holed ear, as shown in [Figure 2-4](#) callout 1, and loosen the opposite screw, shown by callout 2.
2. Pivot the rack mount ear at the loosened screw, shown by callout 3, repositioning the rack mount ear so that the three-holed ear is flush with the switch I/O port side of the device.
3. Reinsert the front screw, shown by callout 4, and retighten the middle screw, shown by callout 5.
4. Repeat steps 1–3 on the other side of the chassis.

**Figure 2-4 Flush Mount Switch I/O Ports Front Configuration**

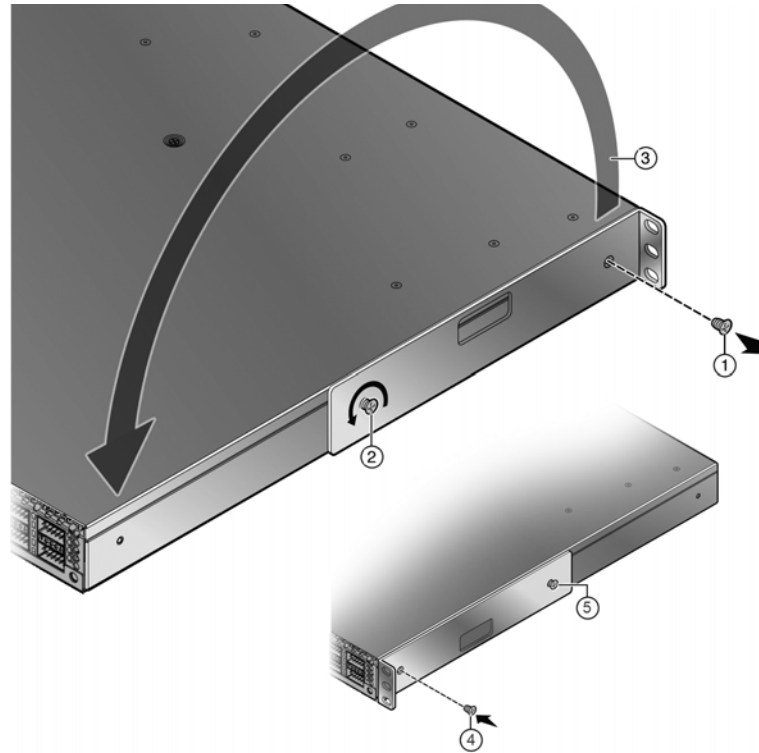

- |                                |                             |
|--------------------------------|-----------------------------|
| 1 Ear mount screw removal      | 4 Ear mount screw insertion |
| 2 Rack mount ear pivot screw   | 5 Pivot screw retightened   |
| 3 Reposition of rack mount ear |                             |
- 

### Mid-Mount Switch I/O Ports Facing Front Configuration

The mid-mount, switch I/O ports facing front configuration is depicted in callout 3 of [Figure 2-1](#) on page 2-3. This rack mount configuration requires repositioning the rack mount ears on both sides of the device.

To reposition the rack mount ears for this configuration:

1. Unscrew the two rack mount ear screws as shown by callout 1 of [Figure 2-5](#) on page 2-9.
2. Reposition the rack mount ear, shown by callout 2, with the middle and power supply side screw holes.
3. Reinsert the two rack mount ear screws, shown by callout 3.
4. Repeat steps 1–3 on the other side of the chassis.

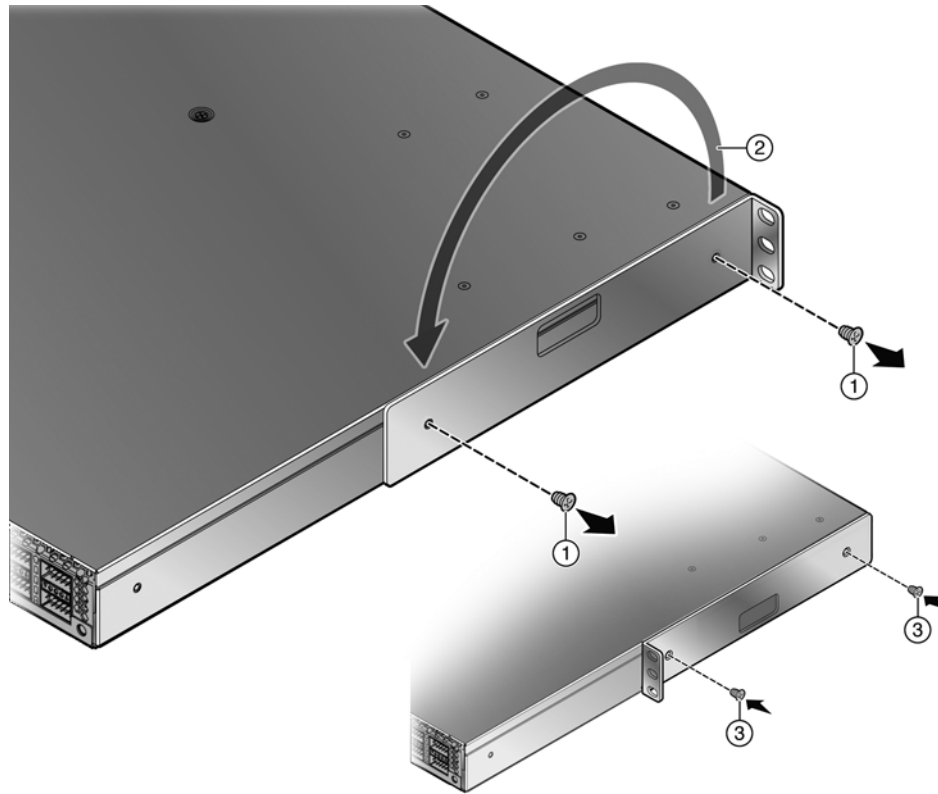

**Figure 2-5 Mid-Mount Switch I/O Ports Facing Front Configuration**

- 1 Ear mount screw removal  
2 Reposition of rack mount ear

- 3 Ear mount screw insertion

### Mid-Mount Power Supply Facing Front Configuration

The mid-mount, power supply facing front, configuration is depicted in callout 4 of [Figure 2-1](#) on page 2-3. This rack mount configuration requires repositioning the rack mount ears on both sides of the device.

To reposition the rack mount ears for this configuration:

1. Unscrew the two rack mount ear screws as shown by callout 1 of [Figure 2-6](#) on page 2-10.
2. Reposition the rack mount ear towards the switch I/O ports end of the device, shown by callout 2 and the thick black arrow. The three-holed ear is now located in the middle of the device, still facing the power supply side.
3. Reinsert the two rack mount ear screws, shown by callout 3.
4. Repeat steps 1–3 on the other side of the chassis.

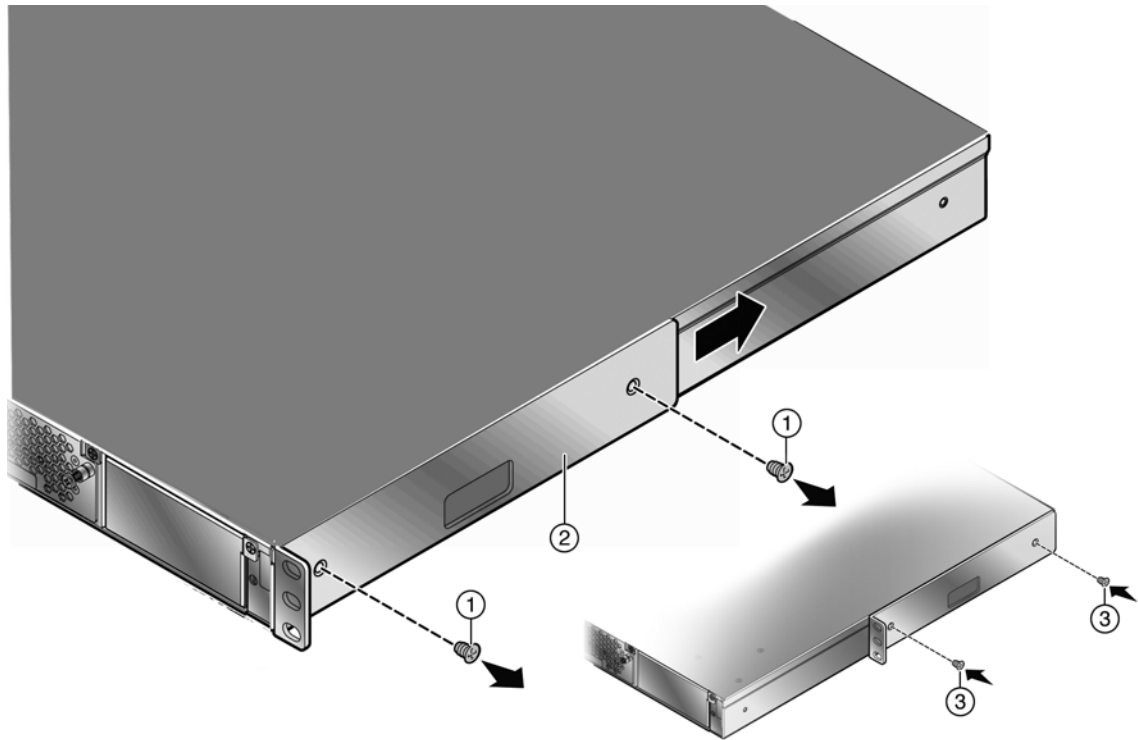
**Figure 2-6 Mid-Mount Power Supply Front Configuration**

- 1 Ear mount screw removal  
2 Reposition of rack mount ear

- 3 Ear mount screw insertion

## Securing the 7100G-Series Switch to the Rack



**Warning:** Before rack-mounting the device, ensure that the rack can support it without compromising stability. Otherwise, personal injury and/or equipment damage may result.

**Advertencia.** Antes de montar el equipo en el rack, asegurarse que el rack puede soportar su peso sin comprometer su propia estabilidad, de otra forma, daño personal o del equipo puede ocurrir.

**Warnhinweis:** Überzeugen Sie sich vor dem Einbau des Gerätes in das Rack von dessen Stabilität, ansonsten könnten Personenschäden oder Schäden am Gerät die Folge sein.

**Avertissement:** Avant de monter l'appareil sur le bâti, assurez-vous que l'étagère peut en supporter le poids sans en compromettre la stabilité. Cela pourrait, dans le cas contraire, entraîner des blessures ou des dommages matériels.



**Notes:** The rack mounting ear provides three holes for securing the 7100G-Series switch to the rack. Use at least two screws or fasteners appropriate to your rack on each side when securing the 7100G-Series switch to the rack.

It is recommended that power supplies be installed after the 7100G-Series switch has been secured to the rack to minimize weight that must be supported when installing rack screws.

To secure the 7100G-Series switch to the rack:

1. Ensure that the rack mount ears are properly installed based upon the discussion in section [“Rack Mount Ear Positioning”](#) on page 2-7.
2. Align the rack mount ear holes with the front rack post holes in either a flush ([Figure 2-7](#)) or mid-mount ([Figure 2-8](#) on page 2-11) configuration.

- Secure the 7100G-Series switch to each rack post with at least two screws or fasteners appropriate to the rack as shown in callout 1 of the appropriate figure ([Figure 2-7](#) or [Figure 2-8](#)).

**Figure 2-7 Securing the 7100G-Series Switch to the Rack in a Flush Mount Configuration**

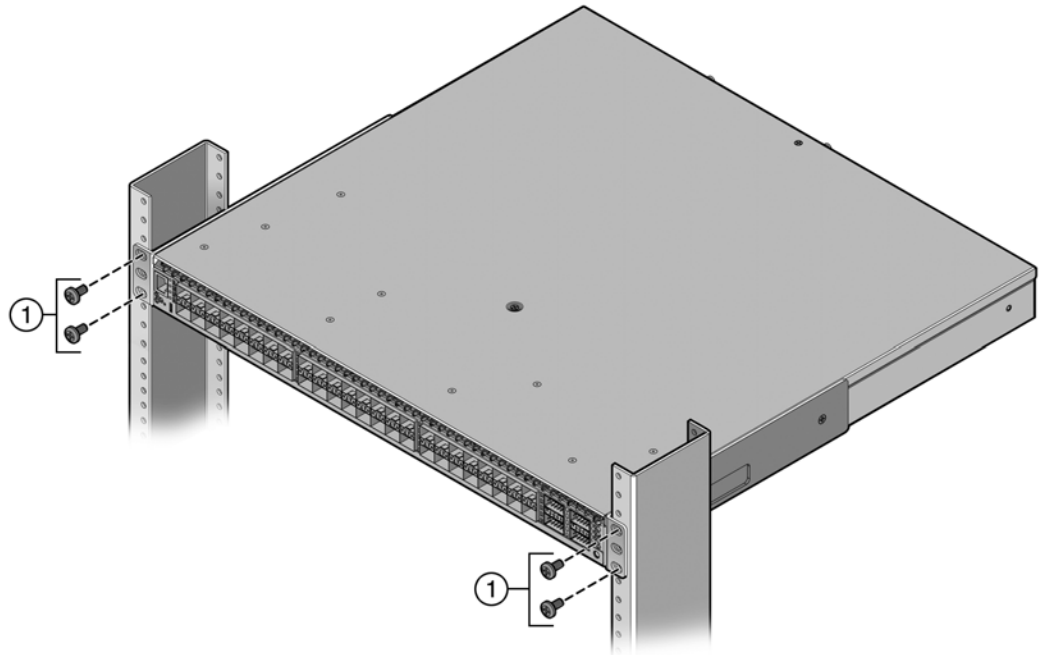

- 4 or 6 screws or fasteners appropriate to the rack

**Figure 2-8 Securing the 7100G-Series Switch to the Rack in a Mid-Mount Configuration**

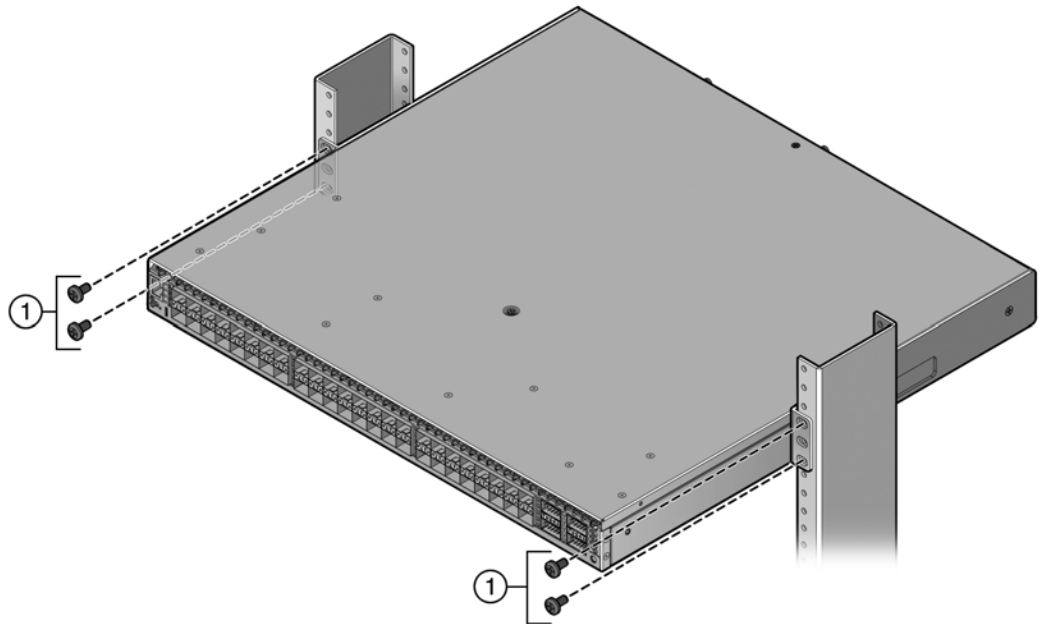

- 4 - 6 screws or fasteners appropriate to the rack

You can now install the 7100G-Series power supplies. See [“Installing the Power Supplies”](#) on page 2-12.

## Flat Surface Installation

For flat surface installation, optionally attach the adhesive rubber feet to the bottom of the 7100G-Series switch.

To attach the rubber feet to the bottom of the 7100G-Series switch:

1. Place the 7100G-Series switch upside down on a sturdy, flat surface.
2. Remove the adhesive backing from the four rubber feet.
3. Adhere the rubber feet to the round, recessed areas on the bottom of the 7100G-Series switch.

You can now install the 7100G-Series power supplies. See [“Installing the Power Supplies”](#) on page 2-12.

## Unpacking the Power Supplies

The power supply modules are shipped in boxes separate from the 7100G-Series switch. To unpack a power supply:

1. Remove the power supply from the shipping box and slide the two foam end caps off the unit.  
Save the shipping box and materials in the event the unit must be reshipped.
2. Verify the contents of the box using [Table 2-4](#).
3. Remove the power supply from its protective plastic bag.
4. Examine the power supply carefully, checking for damage.

If there are any signs of damage, DO NOT install the power supply; instead, contact Enterasys Networks. Refer to [“Getting Help”](#) on page xvii for details.

**Table 2-4 Contents of 7100G-Series Power Supply Carton**

Item	Quantity
Power supply (71A-PS-A, 71A-PS-B, 71A-POE-A, or 71A-POE-B)	1
For USA shipments: NEMA Power Cord 5-15, C13 Type of power cord is dependent on country of installation.	1
IMPORTANT AIR FLOW NOTICE	1

## Installing the Power Supplies

If you are installing only one power supply, you must put the power supply in the left power supply bay (labeled PS1). The 7100G-Series switch ships without a coverplate for the PS1 bay.

To install the power supplies in the 7100G-Series switch:

1. Use appropriate antistatic protection when handling power supplies.
2. Perform a visual verification of the power supply air flow direction, verifying that the power supply air flow direction agrees with the installed fan module air flow direction. For details, see [“Power Supply Air Flow and Switch Fan Module Air Flow”](#) on page 2-4.

3. Holding the power supply by the handle and bottom, align the power supply with the left power supply bay (labeled PS1).
4. Slide the power supply forward until it is plugged into the chassis connector and the lock tab clicks to the right. Pull on the power supply handle to ensure that the power supply is firmly in place. See [Figure 2-9](#).

**Figure 2-9 Installing a Power Supply**

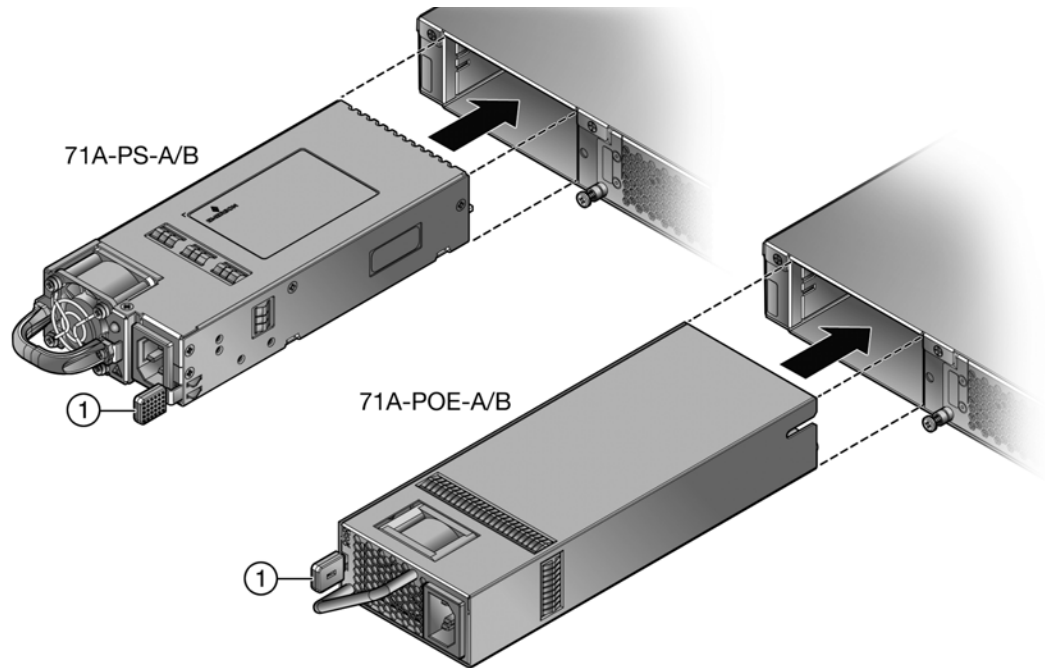

1 Lock Tab

5. If you are installing a second power supply, remove the coverplate from the right power supply bay by unscrewing the screw that attaches the coverplate to the 7100G-Series switch and rotating the coverplate out of its position from right to left before disengaging it from the chassis (see [Figure 2-10](#) on page 2-14). Reinstall the screw once the cover plate is removed.

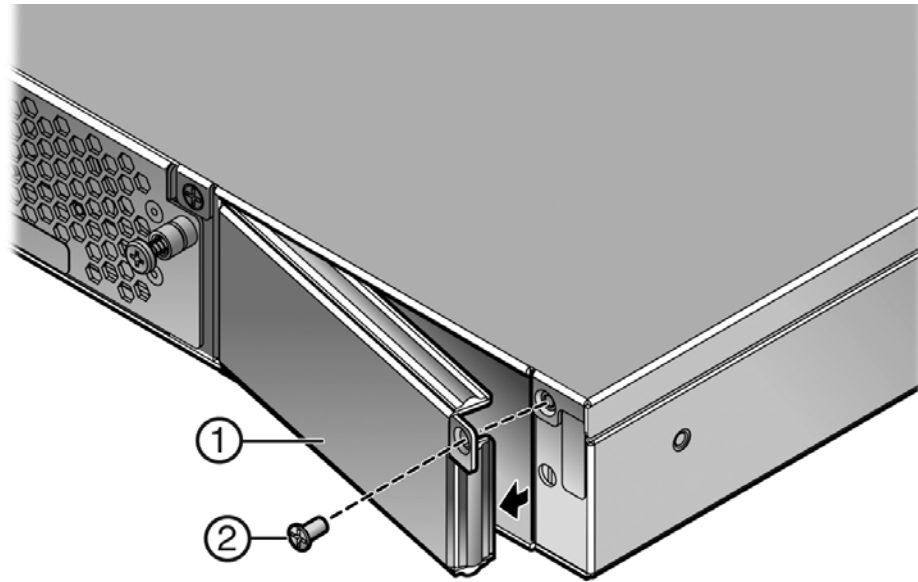
**Figure 2-10 Removing the Power Supply Bay Coverplate**

1 Coverplate

2 Coverplate Screw

Keep the coverplate in the event you need to revert to a single power supply configuration. If a power supply is not installed, the coverplate must be in place for proper air flow.

6. Repeat steps 2-3 to install the power supply in the right power supply bay.

## Powering Up the 7100G-Series Switch

To connect the 7100G-Series switch to the power sources:

1. Plug a power cord into each power supply's AC power receptacle.
2. Plug the cord into a dedicated grounded AC outlet.

In the case of a two power supply configuration, to take advantage of redundancy capabilities, plug each power cord into a separate dedicated AC outlet.

The system PWR LED, located on the switch I/O port panel, turns ON (green) and the CPU LED turns red until the 7100G-Series switch completes its initialization. See [Figure 3-3](#) on page 3-4 for the PWR and CPU LED locations. It takes under 30 seconds for the 7100G-Series switch to boot up.



**Note:** If the power-up sequence is interrupted on the 7100G-Series switch, it may run an extended diagnostics sequence that may take up to two minutes to complete.

When the initialization process is successful, the CPU LED turns green. If the CPU LED does not turn green, refer to [Chapter 3, Troubleshooting](#), for troubleshooting information.

## Installing the Power Cord Retention Clip Assembly

The 7100G-Series switch comes with two optional power cord retention clip assemblies. Power cord retention clips provide added security against the inadvertent removal of the power cord from the the power supply AC receptacle.

To install the power cord retention clip assembly:

1. Holding the strap piece with the rough side facing away from the power supply, shown by callout 2 of [Figure 2-11](#) on page 2-15, insert the strap piece into the hole to the right of the power cord receptacle, shown by callout 1.
2. Slide the power cable clamp, shown by callout 3, onto the strap piece with the tab on the clamp piece facing out.
3. Insert the power cord in the open clamp.
4. Close the clamp piece.

To open the clamp piece, push down the clamp release tab, shown by callout 4.

**Figure 2-11 Installing the Power Cord Clip Assembly in the Power Supply**

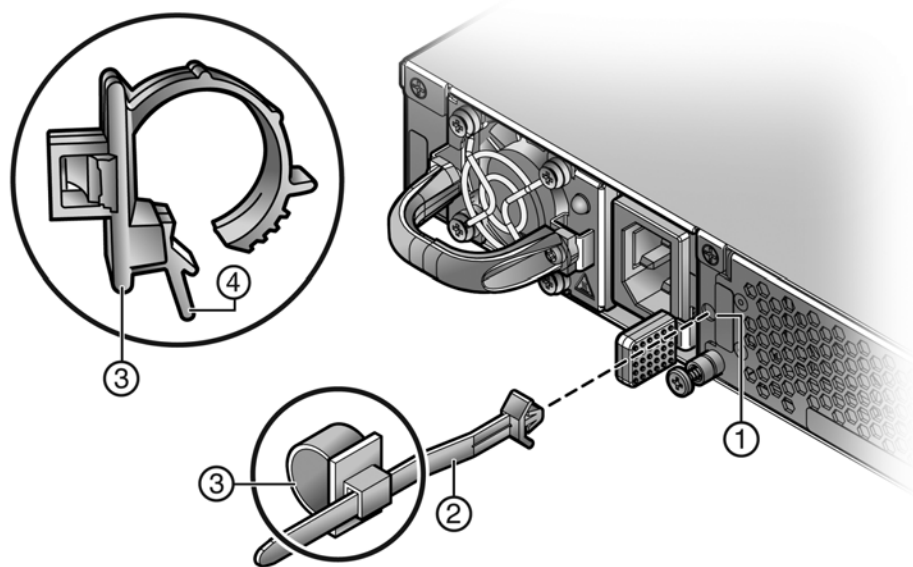

- |   |   |   |                   |
|---|---|---|-------------------|
| 1 | Retention clip receptacle                                   | 3 | Power cable clamp |
| 2 | Retention clip strap piece, smooth side facing power supply | 4 | Clamp release tab |

## Connecting to the Network

This section provides the procedures for connecting Category 6 unshielded twisted pair (UTP) segments or SFP+ or QSFP+ pluggable transceivers from the network or other devices to the 7100G-Series switch.



**Note:** If the 7100G-Series switch is being installed in a network using Link Aggregation, there are rules concerning the network cable and port configurations that must be followed for Link Aggregation to operate properly. Before connecting the cables, refer to the *Enterasys 7100-Series Configuration Guide* for configuration information. For details on how to obtain manuals, refer to [“Related Documents”](#) on page xvi.

### Connecting Category 5E Ethernet Cables to the BASE-T Ports

The fixed BASE-T (RJ45) front panel connections of the 71G21K2L2-48P and 71G21K2L2-24P24 are 10/100/1000Mb PoE (.at+.af capable) ports. They have internal crossovers and support

automatic-polarity sensing which eliminates the need for a crossover cable, regardless of whether the connection is to another network device or a workstation.



**Note:** All RJ45 front panel ports on the 71G21K2L2-48P and 71G21K2L2-24P24 support Category 5E or better cabling.

1. Ensure that the far-end device connected to the other end of the segment is powered ON.
2. Connect the far-end device's twisted pair segment into the appropriate 7100G-Series switch BASE-T port connector.
3. Verify that a link exists by checking that the port RX (Receive) LED is ON (flashing amber, blinking green, or solid green).

If the RX LED is OFF and the TX (Transmit) LED is not blinking amber, perform the following steps until it is on:

- a. Verify that cabling is Category 5E or better.
- b. Verify that the device at the other end of the twisted pair segment is on and properly connected to the segment.
- c. Verify that the BASE-T connectors on the twisted pair segment have the proper pinouts and check the cable for continuity.

If a link is not established, refer to [Chapter 3, Troubleshooting](#), for details.

4. Repeat steps 1–3, until all connections have been made.

## Connecting Pluggable Transceivers to the SFP+ and QSFP+ Ports

This section describes how to install an SFP+ and QSFP+ pluggable transceiver in appropriate 7100G-Series switch ports. See [Figure 1-1](#) on page 1-1 and [Figure 1-2](#) on page 1-2 for appropriate pluggable transceiver port locations for your 7100G-Series switch.

For a list of supported SFP+ and QSFP+ pluggable transceivers and their specifications, refer to the 7100-Series firmware *Release Notes* for the latest compatibility matrix for pluggable transceivers. You can also refer to the datasheet located at the following URL:

<http://www.enterasys.com/products/transceivers-ds.pdf>



**Note:** A 40Gb QSFP+ port can be configured as four 10Gb SFP+ ports. The 10Gb, QSFP+ to SFP+ adaptor cables (model numbers: 10GB-4-C03-QSFP, 10GB-4-F10-QSFP, or 10GB-4-F20-QSFP) provide for the single QSFP+ to four SFP+ cable conversion. See the **set port speed** command information *Enterasys 7100-Series CLI Reference* for port configuration details. The two 10Gb ports are taken off-line when 40Gb ports are used in 4x10Gb mode.



**Note:** The 10GB-LRM-SFPP SFP+ transceiver cannot be used in QSFP+ ports when using the Enterasys QSFP+ to SFP+ adapter (Model number QSFP-SFPP-ADPT) to support 10 Gigabit Ethernet SFP+ transceivers in QSFP+ ports. The 10GB-LRM-SFPP SFP+ transceiver is only supported on the 7100 in native SFP+ ports.





**Warning:** Fiber-optic pluggable transceivers use Class 1 lasers. Do not use optical instruments to view the laser output. The use of optical instruments to view laser output increases eye hazard. When viewing the output optical port, power must be removed from the network adapter.

**Advertencia:** Los transmisores receptores de fibra óptica SFP+ y QSFP+ conectables utilizan sistemas de láser clase 1. No emplee instrumentos ópticos para ver la salida del láser. Hacerlo podría incrementar el riesgo de daño en los ojos. Cuando se revise el puerto óptico de salida, deberá cortarse la energía del adaptador de red.

**Warnhinweis:** Faseroptische, steckbare Transceiver der Typen SFP+ und QSFP+ verwenden Laser der Klasse 1. Zur Ansicht der Laserausgabe dürfen keine optischen Geräte verwendet werden, da hierdurch die Wahrscheinlichkeit einer Gefährdung der Augen erhöht wird. Vor der Inspektion des optischen Ausgangsanschlusses muss das Stromkabel des Netzwerkadapters herausgezogen werden.

**Avertissement:** Les émetteurs-récepteurs en fibre optique enfichables ne fonctionnent qu'avec des lasers de classe 1. N'utilisez aucun instrument d'optique pour observer la sortie du laser. L'utilisation d'instruments d'optique augmente les risques de blessure aux yeux. L'alimentation de l'adaptateur de réseau doit être coupée lorsque vous inspectez le port optique de sortie.



**Caution:** Carefully follow the instructions in this manual to avoid damaging the pluggable transceivers and 7100G-Series chassis.

The pluggable transceivers and 7100G-Series chassis are sensitive to static discharges. Use an antistatic wrist strap and observe all static precautions during this procedure. Failure to do so could result in damage to the SFP+, QSFP+, and 7100G-Series. Always leave the SFP+ or QSFP+ in the antistatic bag or an equivalent antistatic container when not installed.

**Precaución:** Siga las instrucciones del manual para no dañar el SFP+, QSFP+ ni el 7100G-Series, puesto que son muy sensible a las descargas de electricidad estática.

Utilice la pulsera antiestática y tome todas las precauciones necesarias durante este procedimiento. Si no lo hace, podría dañar el SFP+, QSFP+ o el 7100G-Series. Mientras no esté instalado, mantenga el SFP+ o QSFP+ en su bolsa antiestática o en cualquier otro recipiente antiestático.

## Preparation

Before installing the pluggable transceiver, proceed as follows:

1. Put on the antistatic wrist strap, shipped with the switch, and attach it to the ground receptacle on the switch I/O port side of the 7100G-Series switch before removing the pluggable transceiver from the anti-static packaging. Refer to the instructions in the anti-static wrist strap package. See [Figure 2-12](#) for the location of the ground receptacle.

**Figure 2-12 7100G-Series Switch Ground Receptacle**

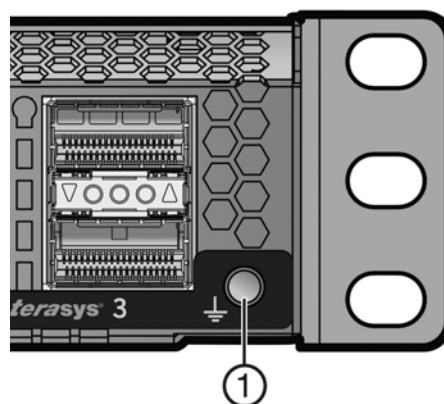

- 1 Ground receptacle

2. Remove the pluggable transceiver from the packaging.
3. If there is a protective dust cover on the pluggable transceiver, do not remove it at this time.

### Installing the Pluggable Transceiver

To install an SFP+ or QSFP+ pluggable transceiver in the 7100G-Series switch:

1. Hold the pluggable transceiver so that the connector will seat properly.
2. Carefully align the pluggable transceiver with the port.
3. Push the pluggable transceiver into the port until the pluggable transceiver clicks and locks into place.

### Removing the Pluggable Transceiver

To remove a pluggable transceiver from a port:



**Caution:** Do NOT remove an SFP+ or QSFP+ pluggable transceiver from a slot without releasing the locking tab located under the front bottom end of the SFP+ or QSFP+. This can damage the SFP+ or QSFP+.

The SFP+, QSFP+, and 7100G-Series are sensitive to static discharges. Use an antistatic wrist strap and observe all static precautions during this procedure. Failure to do so could result in damage to the SFP+, QSFP+, and 7100G-Series. Always leave the SFP+ or QSFP+ in the antistatic bag or an equivalent antistatic container when not installed.

**Precaución:** NO quite el SFP+ o QSFP+ de la ranura sin antes abrir la traba ubicada en la parte frontal del el SFP o SFP+.

Utilice la pulsera antiestática y tome todas las precauciones necesarias durante este procedimiento. Si no lo hace, podría dañar el SFP+, QSFP+ o el 7100G-Series. Mientras no esté instalado, mantenga el SFP+ o QSFP+ en su bolsa antiestática o en cualquier otro recipiente antiestático.

1. Put on the antistatic wrist strap and attach it to the ground receptacle on the switch I/O port side of the 7100G-Series switch before removing the pluggable transceiver. Refer to the instructions in the anti-static wrist strap package. See [Figure 2-9](#) on page 2-13 for the location of the ground receptacle.
2. Remove the cables connected to the pluggable transceiver.
3. Release the pluggable transceiver from the port.
4. Grasp the sides of the pluggable transceiver and pull it straight out of the port.

If storing or shipping the pluggable transceiver, insert its dust protector to protect its fiber-optic ports.

## Multiple 7100G-Series Chassis Stacking (Virtual Switch Bonding)

If you are configuring two or more 7100G-Series chassis for virtual switch bonding, you must create at least one physical connections between each 7100G-Series chassis using the 40Gb ports. If you are bonding three or more physical chassis, it is highly recommended that you create a closed ring configuration by interconnecting the first chassis with the last chassis in the stack. See the *7100-Series Configuration Guide* for Virtual Switch Bonding configuration details.

## Connecting to the COM Port for Local Management

This section describes how to install a UTP cable with RJ45 connectors and adapters to connect a PC or VT series terminal to an 7100G-Series switch to access Local Management. This section also details adapter pinout assignments.

### What Is Needed

The following is a list of the parts that may be needed depending on the connection:

- UTP cable with RJ45 connectors (supplied with the 7100G-Series switch)
- RJ45-to-DB9 female adapter (supplied with the 7100G-Series switch)
- RJ45-to-DB25 female adapter (customer-supplied)

Using the UTP cable with RJ45 connectors and RJ45-to-DB9 adapter, you can connect from the 7100G-Series RJ45 COM port to a PC running a VT series emulation software package.

Using the UTP cable with RJ45 connectors and an optional RJ45-to-DB25 female adapter, you can connect from the 7100G-Series RJ45 COM port to a VT series terminal or VT type terminals running emulation programs for the VT series.

### Connecting to a PC or Laptop

To connect a PC or laptop running the VT terminal emulation to the 7100G-Series COM port:

1. Connect the RJ45 connector at one end of the cable to the COM port on the 7100G-Series switch.
2. Plug the RJ45 connector at the other end of the cable into an RJ45-to-DB9 adapter.
3. Connect the RJ45-to-DB9 adapter to the communications port on the PC.
4. Configure the VT emulation package on your PC or laptop as follows:

Parameter	Setting
Mode	7 Bit Control
Transmit	Transmit = 57600
Bits Parity	8 Bits, No Parity
Stop Bit	1 Stop Bit

When these parameters are set, the Local Management password screen will display. Refer to [“Completing the Installation”](#) on page 2-21 for further information.

### Connecting to a VT Series Terminal

To connect a VT Series terminal to the 7100G-Series COM port, use a UTP cable with RJ45 connectors and an **optional** RJ45-to-DB25 female adapter.

1. Connect the RJ45 connector at one end of the cable to the COM port on the 7100G-Series switch.
2. Plug the RJ45 connector at the other end of the cable into the RJ45-to-DB25 female adapter.
3. Connect the RJ45-to-DB25 adapter to the port labeled COMM on the VT terminal.
4. Turn on the VT terminal and access the Setup Directory.
5. Set the following parameters:

Parameter	Setting
Mode	7 Bit Control
Transmit	Transmit = 57600
Bits Parity	8 Bits, No Parity
Stop Bit	1 Stop Bit

When these parameters are set, the Local Management password screen will display. Refer to [“Completing the Installation”](#) on page 2-21 for further information.

## Adapter Wiring and Signal Assignments

COM Port Adapter Wiring and Signal Diagram			
RJ45		DB9	
Pin	Conductor	Pin	Signal
1	Blue	2	Receive (RX)
4	Red	3	Transmit (TX)
5	Green	5	Ground (GRD)
2	Orange	7	Request to Send (RTS)
6	Yellow	8	Clear to Send (CTS)

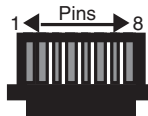

RJ45 Connector (Female)

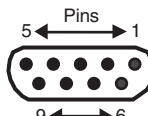

DB9 Connector (Female)

VT Series Port Adapter Wiring and Signal Diagram			
RJ45		DB25	
Pin	Conductor	Pin	Signal
4	Red	2	Transmit (TX)
1	Blue	3	Receive (RX)
6	Yellow	5	Clear to Send (CTS)
5	Green	7	Ground (GRD)
2	Orange	20	Data Terminal Ready

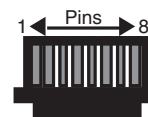

RJ45 Connector (Female)

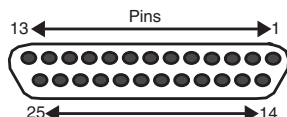

DB25 Connector (Female)

## Completing the Installation

After installing the 7100G-Series switch and making the connections to the network, access the device management startup screen from your PC or terminal connection as described in the following section.



**Note:** This procedure applies only to initial log-in and to logging in to a device not yet configured with administratively-supplied user and password settings.

By default, the 7100G-Series switch is configured with three user login accounts: **ro** for Read-Only access; **rw** for Read-Write access; and **admin** for super-user access to all modifiable parameters. The default password is set to blank (null). For information on changing these default passwords, refer to the *Enterasys 7100-Series Configuration Guide*.

Start the Command Line Interface (CLI) from the device's local console port as follows:

1. Connect a terminal to the local console port as described in "[Connecting to the COM Port for Local Management](#)" on page 2-19. The startup screen displays.

```
login: admin
Password:
```

```
7100G-Series
Command Line Interface
```

```
Enterasys Networks, Inc.
9 Northeastern Blvd.
Salem, NH 03079 U.S.A.
```

```
Phone: +1 603 952 5000
E-mail: support@enterasys.com
WWW: http://www.enterasys.com
```

```
(c) Copyright Enterasys Networks, Inc. 2012
```

```
Chassis Serial Number: xxxxxxxxxxxxxx
Chassis Firmware Revision: xx.xx.xx
```

```
7100(su)->
```

2. At the login prompt, enter one of the following default user names:
  - **ro** for Read-Only access
  - **rw** for Read-Write access
  - **admin** for Super User access. (This access level allows Read-Write access to all modifiable parameters, including user accounts.)
3. Press **Enter**.
4. The Password prompt displays. Leave this string blank and press **Enter**. The device information and 7100G-Series switch prompt appear as shown above.

The 7100G-Series switch is now ready to be configured. For information about setting the IP address and configuring Telnet settings for remote access to 7100G-Series switch management, refer to the *Enterasys 7100 Series Configuration Guide*.

The CLI commands enable you to initially set up and perform more involved management configurations. The *Enterasys 7100 Series Configuration Guide* is available online at:

<https://extranet.enterasys.com/downloads/Pages/default.aspx>



## Troubleshooting

This chapter provides information concerning the following:

For information about...	Refer to page...
<a href="#">LEDs</a>	<a href="#">3-1</a>
<a href="#">Troubleshooting Checklist</a>	<a href="#">3-6</a>
<a href="#">Replacing the 7100G-Series Fan Module</a>	<a href="#">3-8</a>
<a href="#">Removing a Power Supply</a>	<a href="#">3-9</a>
<a href="#">Using the OFFLINE/RESET Button</a>	<a href="#">3-10</a>

## LEDs

The 7100G-Series switch has port, system, and power supply LEDs.

### Port LEDs

On the 7100G-Series switch, you can view:

- The link, receive, and transmit activity on the RX and TX LEDs for the SFP+ ports. See [Figure 3-1](#) on page 3-2 for the port LED location (Callouts 1 - 4). See [Table 3-1](#) on page 3-2 for LED state definitions.
- The link and data transmission activity on the port status LED for the QSFP+ ports. See [Figure 3-1](#) on page 3-2 for the port LED location (Callouts 5 and 6). See [Table 3-2](#) on page 3-3 for LED state definitions.
- The link and data transmission activity on the port status LED for the 1000 BASE-T (RJ45) ports (see [Figure 3-2](#) on page 3-3. See [Table 3-3](#) on page 3-3 for LED state definitions.
- The PoE status for PoE capable (10/100/1000 PoE (.at+ .af capable) RJ45 ports. See “[PoE Port Status LEDs](#)” on page D-2 for PoE LED details.

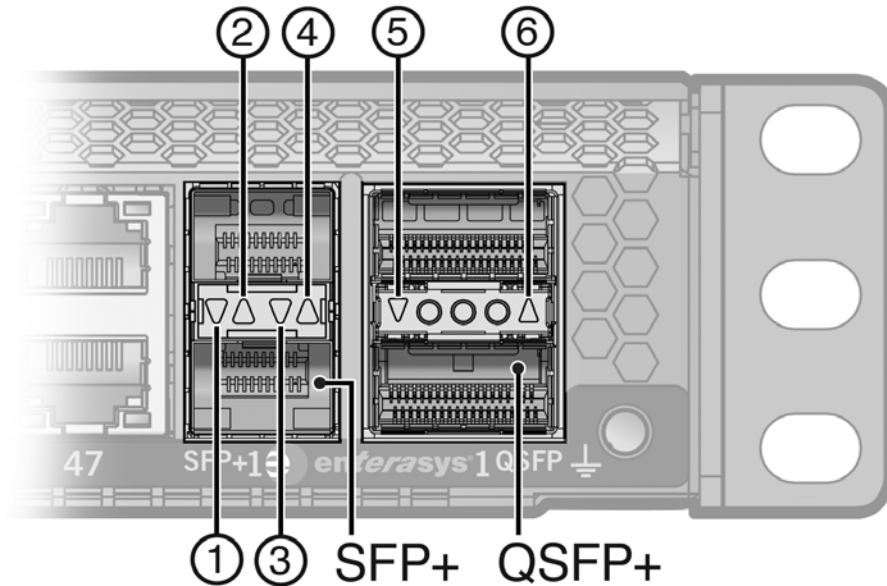
**Figure 3-1 SFP+ and QSFP+ Port LEDs**

- |                               |                               |
|-------------------------------|-------------------------------|
| 1 SFP+ RX LED for bottom port | 4 SFP+ TX LED for top port    |
| 2 SFP+ RX LED for top port    | 5 QSFP+ Lower Port Status LED |
| 3 SFP+ TX LED for bottom port | 6 QSFP+ Upper Port Status LED |



**Note:** Though [Figure 3-1](#) shows SFP+ and QSFP+ ports, the LEDs are the same for both SFP and SFP+ ports.

[Table 3-1](#) describes the LED indications for the RX and TX LEDs for the SFP+ ports and provides recommended actions.

**Table 3-1 SFP+ Port LEDs**

LED	Color	State	Recommended Action
RX (Receive)	None	No link. No activity. Port enabled or disabled.	None.
	Green (solid)	Link present, port enabled, no traffic is being received by the interface.	None.
	Yellow (blinking)	Link present, port enabled, traffic is being received by the interface.	None.
TX (Transmit)	None	Port enabled, but no activity.	If you know the port should be active and is not, contact Enterasys Technical Support.
	Green (blinking)	Indicates data transmission activity. Flashing frequency indicates the data rate.	None.
	Yellow (solid)	Fault or error (collision).	None, unless activity is high; in which case, check for network configuration problems or a defective device.



Table 3-2 describes the LED indications for the port status LED for the QSFP+ ports and provides recommended actions.

**Table 3-2 QSFP+ Port LEDs**

Color	State	Recommended Action
None	No link. No activity. Port enabled or disabled.	If you know the port should be active and is not, contact Enterasys Technical Support.
Green (solid)	Link present, port enabled, no traffic is being received by the interface.	None.
Yellow (blinking)	Link present, port enabled, traffic is being received by the interface.	None.

Table 3-3 on page 3-3 describes the LED indications for the port status LED for the 1000 BASE-T ports and provides recommended actions.

**Figure 3-2 1000 BASE-T (RJ45) Port LEDs**

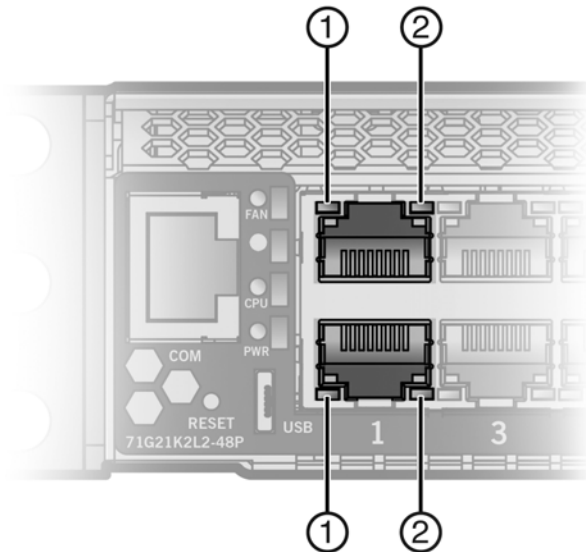

1 Receive Port Status LED

2 Transmit Port Status LED

**Table 3-3 BASE-T Port LEDs**

Rx Color	Tx Color	State	Recommended Action
None	None	No link. No activity. Port enabled or disabled.	If you know the port should be active and is not, contact Enterasys Technical Support.
Green (solid)	Green (solid)	Link present, port enabled, no traffic is being received by the interface.	None.
Amber (blinking/solid)	Green (blinking)	Link present, port enabled, traffic is being received by the interface.	None.
	Amber (solid)	A transmit fault or error condition exists	Contact Enterasys Technical Support if assistance is required.

## System LEDs

Figure 3-3 shows the 7100G-Series system fan module, CPU, and power LEDs.

**Figure 3-3 7100G-Series System LEDs**

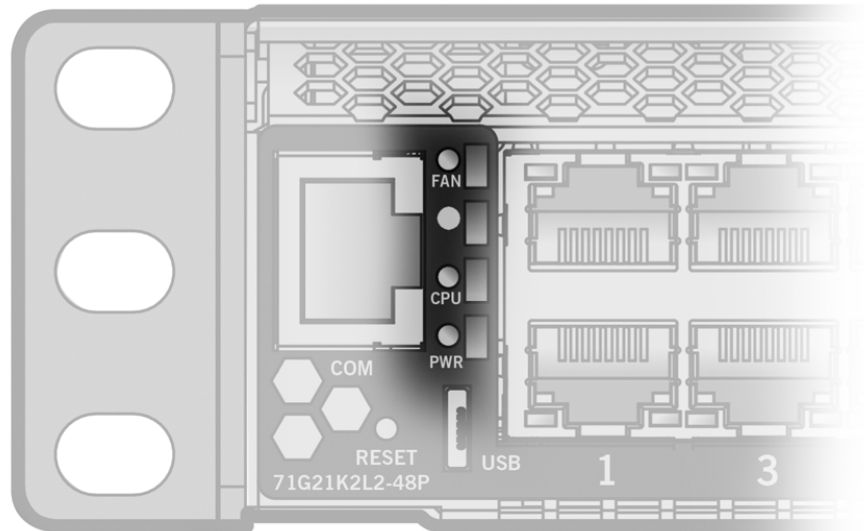

Table 3-4 describes the LED indications for the system LEDs and provides recommended actions.

**Table 3-4 System LEDs**

LED	Color	State	Recommended Action
FAN	Off	Fan module is off or booting up.	None.
	Green	Fan module operating normally.	None.
	Red	One or more of the following conditions has occurred: <ul style="list-style-type: none"> <li>• Temperature is out of range.</li> <li>• The fan controller has failed.</li> <li>• The fan module has failed.</li> </ul>	Use the <b>show system</b> CLI command to check the exact condition of the fan module.  If the fan module has failed, replace the fan module. See <a href="#">“Replacing the 7100G-Series Fan Module”</a> on page 3-8.
CPU	Off	Power off.	Ensure chassis has adequate power.
	Amber	<b>Blinking.</b> Device in bootup process.	None.
		<b>Solid.</b> Testing.	If the LED remains amber for several minutes, contact Enterasys Networks for technical support.
	Green	<b>Blinking.</b> Image starts running.	None.
		<b>Solid.</b> Functional.	None.
	Red	<b>Solid.</b> Processor in reset.	None.
	Green and Amber	<b>Blinking.</b> Indicates that the 7100G-Series switch is in the process of shutting down.	None. This state is activated when the RESET button is pressed for less than 1 second to start an orderly shutdown.
Amber and off	<b>Alternating (67% on, 33% off).</b> Indicates a shutdown is complete. The indication will hold for 60 seconds then automatically restart.	While in this state, you have 60 seconds before the 7100G-Series switch will reboot.	

**Table 3-4 System LEDs (continued)**

LED	Color	State	Recommended Action
	Blue	<b>Blinking.</b> Virtual Switch Bonding is enabled, but the devices are not bonded	None.
		<b>Solid.</b> Virtual Switch Bonding is enabled, and the devices are bonded.	None.
PWR	Off	The 7100G-Series switch is not receiving power from the power supplies.	Ensure the power cords are plugged in and power is available at the source. Contact Enterasys Networks for technical support.
	Green	<b>Functional.</b> Indicates one of the following conditions: <ul style="list-style-type: none"> <li>A single power supply is present and operating normally.</li> <li>Two power supplies are present and operating normally.</li> </ul>	None.
	Amber	One of the following conditions has occurred: <ul style="list-style-type: none"> <li>Two power supplies are present but only one is operating normally while the other is not connected.</li> <li>Two power supplies are present but only one is operating normally while the other indicates a fault.</li> <li>Both power supplies are faulty but the 7100G-Series switch is still receiving power.</li> <li>Power supplies are operating in additive (non-redundant) mode.</li> <li>Other internal fault.</li> </ul>	Ensure the power cords are plugged in and power is available at the source. Contact Enterasys Networks for technical support.



**Note:** The PWR LED status indication is based on power supplies being powered on.

Table 3-5 describes the CPU LED when the 7100G-Series switch is in a virtual switch bonding configuration.

**Table 3-5 CPU LED in Virtual Switch Bonding (VSB) Configuration**

Color	State
Green and Blue	<b>Blinking.</b> Image has started and found chassis bonding enabled.
Blue	<b>Solid.</b> Functional (bonding is operational and ready to switch).
Blue	<b>Blinking.</b> Bonding is not functional (non-operational).

## Power Supply LED

The 71A-PS-A/B power supplies have a single LED and 71A-POE-A/B power supplies have two LEDs. Table 3-6 describes the different states of the power supply LEDs.

**Table 3-6 Power Supply LED Status Definitions**

LED Color	Status
Green	<p><b>71A-PS-A/B</b> – Sufficient power is available to the system.</p> <p><b>71A-POE-A/B</b> – LED labeled AC when green indicates that AC power is attached. The LED labeled DC when green indicates that the power supply is delivering power. Normally the DC LED turns on a few seconds after the AC.</p>
Off	No AC power to the power supply or power supply malfunctioning.

## Troubleshooting Checklist

If the 7100G-Series switch is not working properly, refer to [Table 3-7](#) for a checklist of problems, possible causes, and recommended actions to resolve the problem.

**Table 3-7 Troubleshooting Checklist**

Problem	Possible Cause	Recommended Action
All LEDs are OFF.	Loss of power.	Ensure the 7100G-Series switch was installed properly according to the installation instructions in <a href="#">Chapter 2, Installation</a> , and that the chassis has power.
No Local Management Password screen.	Incorrect terminal setup.	Refer to the <i>7100-Series Configuration Guide</i> for proper setup procedures.
	Improper console cable pinouts.	Refer to <a href="#">Appendix A, Specifications</a> for proper COM port pinouts.
	Corrupt firmware image or hardware fault.	If possible, attempt to download the image to the 7100G-Series switch again. Refer to <a href="#">Appendix B, Clearing the Persistent Storage or System Password</a> for instructions to clear NVRAM.
Cannot navigate beyond Password screen.	Improper username/ password combination entered.	If the username/password combination has been forgotten, refer to <a href="#">Appendix B, Clearing the Persistent Storage or System Password</a> for instructions on how to clear the password, resetting it to the default value of null (blank), using either the boot loader <b>clearpassword</b> command or set mode switch method.
Cannot contact the 7100G-Series switch through in-band management.	IP address not assigned.	See <i>Enterasys 7100-Series Configuration Guide</i> for instructions to assign an IP address.
	Port is disabled.	Enable port. See the <i>Enterasys 7100-Series Configuration Guide</i> for instructions to enable/disable ports.
	Host Port policy and/or management VLAN is incorrectly configured, or not configured.	Verify that a management VLAN exists and that it is associated with the Host Port. Refer to the <i>Enterasys 7100-Series Configuration Guide</i> for information about Host Port and management VLAN configuration.
	No link to device.	Verify that all network connections between the network management station and the 7100G-Series switch are valid and operating.  If the problem continues, contact Enterasys Networks for technical support.

**Table 3-7 Troubleshooting Checklist (continued)**

<b>Problem</b>	<b>Possible Cause</b>	<b>Recommended Action</b>
Port(s) goes into standby for no apparent reason.	Loop condition detected.	<p>Verify that Spanning Tree is enabled. Refer to the <i>Enterasys 7100-Series Configuration Guide</i> for the instructions to set the type of STP.</p> <p>Review the network design and delete loops.</p> <p>If the problem continues, contact Enterasys Networks for technical support.</p>
User parameters (IP address, device and device name, etc.) were lost when the 7100G-Series power was cycled or the OFFLINE/RESET button was pressed.	<p>Position of Mode switch (7), Persistent Data Reset, was changed sometime before either cycling power or pressing the RESET button, causing the user-entered parameters to reset to factory default settings.</p> <p>Clear Persistent Data that was set through Local Management.</p>	<p>Reenter the lost parameters as necessary. Refer to the <i>Enterasys 7100-Series Configuration Guide</i> for the instructions to configure the device.</p> <p>If the problem persists, contact Enterasys Networks for technical support.</p>

## Replacing the 7100G-Series Fan Module

The 7100G-Series switch is cooled by a fan module accessible from the power supply side of the unit. If the FAN LED and the output of the CLI **show system** command indicate that the fan module has failed, you must replace the failed fan module.



**Note:** The 7100G-Series fan module is hot-swappable. Do not uninstall a failed fan module until its replacement is available. All 7100G-Series switch components and cover plates must be installed to ensure proper air flow.

The replacement fan kit, 71A-71GFAN, which you must order separately, contains one replacement fan.

To replace the failed fan module:

1. Unscrew the two captive screws of the failed fan module as shown in [Figure 3-4](#) on page 3-8.
2. Following the discussion in “[Power Supply Air Flow and Switch Fan Module Air Flow](#)” on page 2-4, ensure that the new fan module air flow direction agrees with the installed 7100G-Series switch configuration.
3. If a non-default air flow is required, see “[Reversing the Fan Module Air Flow](#)” on page 2-5 for directions on how to reverse the fan unit direction.
4. Once you have ensured that the fan module air flow is appropriate to your system configuration, slide the currently installed fan module forward until it is unplugged from the device as shown in [Figure 3-4](#).

**Figure 3-4** Removing the Fan Module

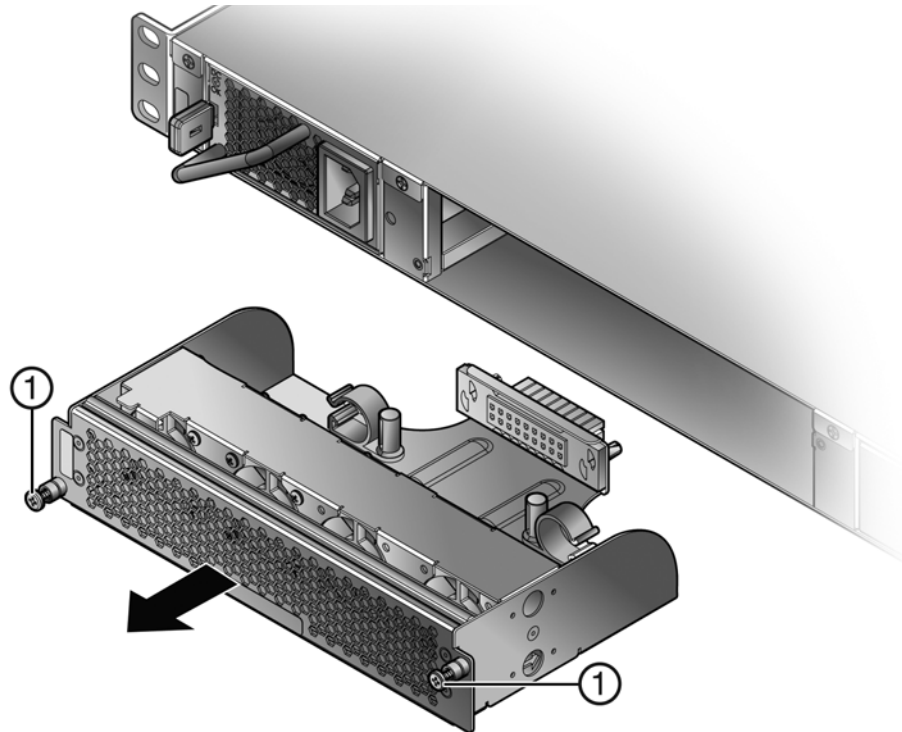

1 Fan Module Screws

5. Align the new fan module with the fan module opening.

6. Insert the module into the fan module opening, applying enough pressure that the fan module is flush with the device.
7. Secure the two fan module captive screws.

## Removing a Power Supply

To remove a power supply from the 7100G-Series switch:

1. Use appropriate antistatic protection when handling power supplies.
2. If a power cord retention clip is securing the power cord, push down on the retention clip clamp tab to open the clamp and disengage the power cord from the clamp.
3. Unplug the associated power cord from the AC inlet.
4. Do not remove the power supply in power supply bay PS1 until a replacement power supply is available.
5. Remove the power supply by simultaneously pressing the power supply lock tab in the direction specified for your unit in [Figure 3-5](#), grasping the handle, and pulling the power supply straight out of the 7100G-Series switch.
6. If you are removing the power supply from power supply bay PS2, and you are not immediately installing another power supply, reinstall the coverplate that comes with the 7100G-Series switch over the empty PS2 power supply bay.



**Caution:** If you plan to operate the chassis with only one power supply, the power supply must be installed in the left power slot labeled PS1 and the coverplate must be in place in the right power slot to contain EMI radiation and ensure proper air circulation.

**Precaución:** Si desea trabajar sólo con una fuente de poder, no olvide colocar la tapa en el compartimiento de la fuente de poder que haya eliminado, para reducir la interferencia electromagnética y para asegurar una buena ventilación.

**Figure 3-5 Removing the Power Supply**

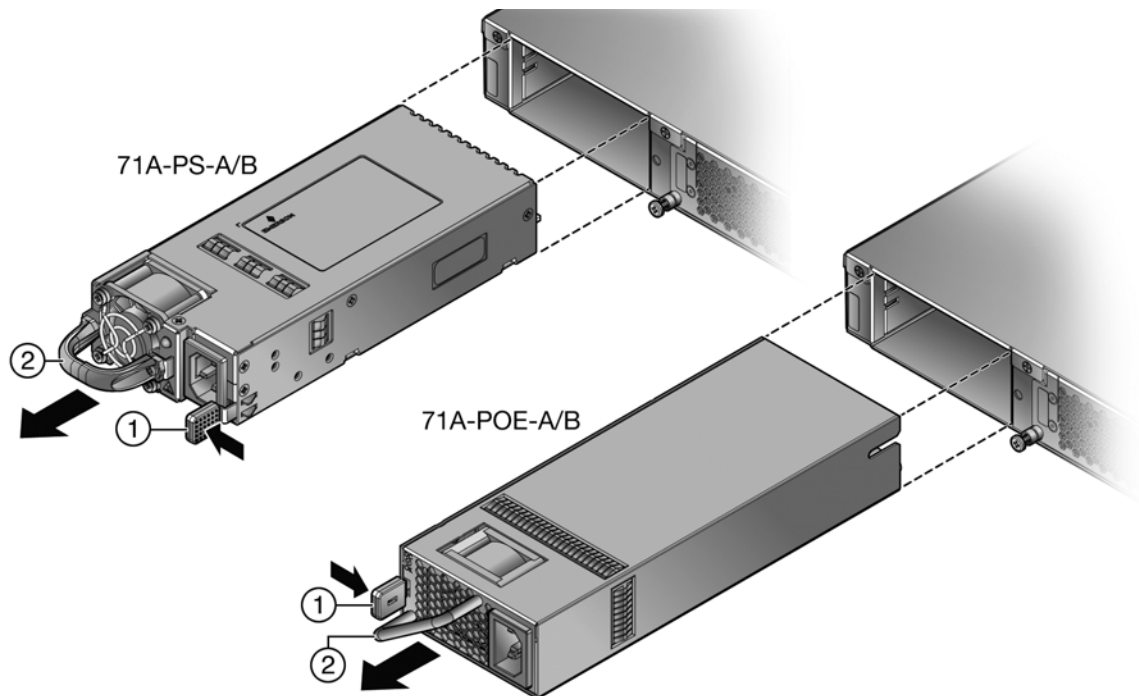

## Using the OFFLINE/RESET Button

You can shut down a 7100G-Series switch using the OFFLINE/RESET button, shown in [Figure 3-6](#), which is slightly recessed behind the 7100G-Series switch faceplate. There are two procedures to shut down a 7100G-Series switch:

- [Recommended Shutdown Procedure Using OFFLINE/RESET Button](#)
- [Last Resort Shutdown Procedure Using OFFLINE/RESET Button](#) (This procedure is not recommended)

**Figure 3-6** OFFLINE/RESET Button

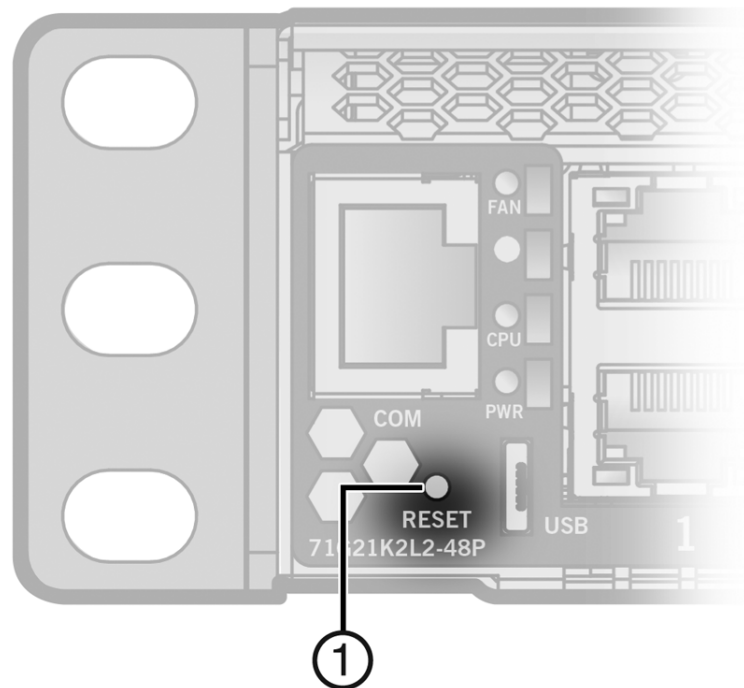

1 OFFLINE/RESET button

### Recommended Shutdown Procedure Using OFFLINE/RESET Button

Before shutting off power to a 7100G-Series switch, **press or tap** on its OFFLINE/RESET button for less than one second.

The 7100G-Series system CPU LED changes from solid green to blinking between green and amber, indicating that the 7100G-Series switch is shutting down. At the end of the shutdown routine, the CPU LED changes to a 67%/33% sequence of amber/off, respectively, indicating the system is in a halt state. At this time it is safe to restart the 7100G-Series switch.

When you initiate a controlled shutdown with the OFFLINE/RESET button, you have 60 seconds from the time the CPU LED starts flashing amber/off until the device automatically restarts.



## Last Resort Shutdown Procedure Using OFFLINE/RESET Button



**Caution:** This method of shutting down a 7100G-Series switch is not recommended except as a last resort, because all processes currently running on the 7100G-Series switch will be interrupted resulting in loss of frames.

**Precaución:** No se recomienda utilizar este método para apagar los módulos 7100G-Series. Recorra a él sólo como último recurso, puesto que interrumpe todos los procesos del módulo en funcionamiento, lo que podría resultar pérdidas de frames.

To reset an 7100G-Series switch without it performing an orderly shutdown routine, **press and hold** the OFFLINE/RESET button for approximately 6 seconds.





# Specifications

This appendix provides the following information:

For information about...	Refer to page...
<a href="#">7100G-Series Switch Specifications</a>	A-1
<a href="#">Pluggable Transceiver Specifications</a>	A-2
<a href="#">COM Port Pinout Assignments</a>	A-2
<a href="#">Regulatory Compliance</a>	A-3

Enterasys Networks reserves the right to change specifications at any time without notice.

## 7100G-Series Switch Specifications

[Table A-1](#) describes I/O ports for the 7100G-Series switch.

**Table A-1 7100-Series Switch Ports**

Item	Port Description
<b>71G21K2L2-48P</b>	
Ports 1 through 48	forty-eight 10/100/1000 PoE (.at + .af capable) RJ45 ports
Uplink Ports 1 and 2	two 1/10Gb SFP+ ports
Uplink Ports 3 and 4	two 10/40Gb QSFP+ ports
<b>71G21K2L2-24P24</b>	
Ports 1 through 24	twenty-four 10/100/1000 PoE (.at + .af capable) RJ45 ports
Ports 25 through 48	twenty-four 100Mb/1Gb SFP ports
Uplink Ports 1 and 2	two 1/10Gb SFP+ ports
Uplink Ports 3 and 4	two 10/40Gb QSFP+ ports
<b>71G11K2L2-48 Ports</b>	
Ports 1 through 48	forty-eight 100Mb/1Gb SFP ports
Uplink Ports 1 and 2	two 1/10Gb SFP+ ports
Uplink Ports 3 and 4	two 10/40Gb QSFP+ ports

Table A-2 describes physical, electrical, and environmental specifications for the 7100G-Series switch.

**Table A-2 Specifications**

Item	Specification
<b>Physical (7100G-Series Chassis)</b>	
Dimensions	4.37 cm H x 44.73cm W x 43.40cm D 1.72" H x 17.61" W x 17.086" D
Approximate Weight	Gross: 7.12 kg (15.7 lb)
Mean Time Between Failure (MTBF)	Refer to the MTBF web site at URL <a href="http://www.enterasys.com/support/mtbf/">http://www.enterasys.com/support/mtbf/</a>
<b>71A-POE-A or 71A-POE-B</b>	
Input Frequency	50 to 60 Hz
Input (Voltage/Current) at Output Power	100 to 240 V AC: 10 - 5A at 800 watts
Approximate Weight	0.86 kg (1.90 lb)
<b>71A-PS-A or 71A-PS-B</b>	
Input Frequency	50 to 60 Hz
Input (Voltage/Current) at Output Power	100 to 240 V AC: 5.29 to 2.2A at 450 watts
Approximate Weight	0.86 kg (1.90 lb)
<b>Environmental</b>	
Operating Temperature	5°C to 40°C (41°F to 104°F)
Storage Temperature	-30°C to 73°C (-22°F to 164°F)
Operating Relative Humidity	5% to 95% (non-condensing)

## Pluggable Transceiver Specifications

For SFP+ and QSFP+ transceiver specifications, refer to the datasheet at the following URL:

<http://www.enterasys.com/products/transceivers-ds.pdf>

## COM Port Pinout Assignments

The COM port is an RJ45 communications port for local access to local management. Refer to the table below for the COM port pin assignments.

**Table A-3 COM Port Pin Assignments**

Pin	Signal Name	Input/Output
1	Transmit Data (XMT)	Output
2	Data Carrier Detect (DCD)	Output
3	Data Set Ready (DSR)	Input
4	Receive Data (RCV)	Input
5	Signal Ground (GND)	NA
6	Data Terminal Ready (DTR)	Output
7	Request to Send (RTS)	Input

**Table A-3 COM Port Pin Assignments (continued)**

Pin	Signal Name	Input/Output
8	Clear to Send (CTS)	NA

## Regulatory Compliance

The 7100G-Series switch meets the safety, electromagnetic compatibility (EMC), and environmental requirements listed in [Table A-4](#):

**Table A-4 Compliance Standards**

Regulatory Compliance	Standard
Safety	UL 60950-1, FDA 21 CFR 1040.10 and 1040.11, CAN/CSA C22.2 No. 60950-1, EN 60950-1, EN 60825-1, EN 60825-2, IEC 60950-1, 2006/95/EC (Low Voltage Directive)
Electromagnetic Compatibility (EMC)	FCC 47 CFR Part 15 (Class A), ICES-003 (Class A), EN 55022 (Class A), EN 55024, EN 61000-3-2, EN 61000-3-3, AS/NZ CISPR-22 (Class A). VCCI V-3. CNS 13438 (BSMI), 2004/108/EC (EMC Directive)
Environmental	2011/65/EU (RoHS Directive), 2002/96/EC (WEEE Directive), Ministry of Information Order #39 (China RoHS)





---

## Clearing the Persistent Storage or System Password

When troubleshooting the 7100G-Series switch it may become necessary to clear the persistent storage in NVRAM or the system password. There are two methods available:

- Enter boot loader mode during the bootup process
- Manually setting a dip switch internal to the device

This appendix details the two methods available for clearing persistent storage or system password on the 7100G-Series switch.

### Clearing Persistent Storage or Password using the Boot Loader Method

Persistent storage can be cleared or the system password reset to factory default using the boot loader by connecting a terminal application to the serial (console) port. Serial console access to the boot loader has been successfully tested with the following applications:

- HyperTerminal
- TeraTerm

Any other terminal applications may work but are not explicitly supported.

To either clear the 7100G-Series switch persistent storage or only the system password, proceed as follows:

1. With the console port connected, power up the device. The following message displays:

```
Boot ROM Initialization, Version 01.00.02

Copyright (c) 2012 Enterasys Networks, Inc.
SDRAM size: 1024 MB
Testing SDRAM... PASSED.
Loading Boot Image: 0x.00.yy... DONE.
Uncompressing Boot Image... DONE.
```

2. Once the boot image is finished uncompressing, you receive a message indicating you have 3 seconds to access the bootloader menu by pressing any key. Press a key and the system image loader prompt displays:

```
###You have 3 seconds to access the bootloader menu###
Press any key to enter System Image Loader menu
PressAnyKey
```

[System Image Loader]:

3. Enter the **clearnvram** command to clear all of persistent storage; enter **clearpw** to only clear the system password:

[System Image Loader]:**clearnvram** or **clearpw**

[System Image Loader]:

4. Power the system off and back on to reboot the system using the factory defaults.
5. Enter admin at the username prompt.
6. Enter a carriage-return at the password prompt.
7. See the Image Configuration and File Management chapter of the *Enterasys 7100 Series Configuration Guide* for instructions on restoring a config if you cleared the NVRAM.

## Clearing System Storage or Password Using the Dip Switch Method



**Electrical Hazard:** Only qualified personnel should perform installation procedures.

**Riesgo Eléctrico:** Solamente personal calificado debe realizar procedimientos de instalacion.

**Elektrischer Gefahrenhinweis:** Installationen sollten nur durch ausgebildetes und qualifiziertes Personal vorgenommen werden

**Risques d'électrocution:** Seul un personnel qualifié doit effectuer les procédures d'installation.

This section of the appendix covers the following items:

For information about...	Refer to page...
<a href="#">Required Tools</a>	<a href="#">B-3</a>
<a href="#">About the Mode Switches</a>	<a href="#">B-3</a>
<a href="#">Setting the Mode Switches</a>	<a href="#">B-4</a>



**Electrical Hazard:** Do not remove any component from the 7100G-Series switch while power is applied to the unit. Hazardous voltages are present and could cause personal injury and/or damage the unit.

Do not power up the 7100G-Series switch again until all components and screws are in place.

**Riesgo Eléctrico:** No debe de remover cualquier componente durante que este conelgado a la corriente, una descarga electrica le puede causar y probocarle daños, al igual que al aparato.

No enchufe a la corriente hasta que todo componente y los tornillos esten en su lugar.

**Elektrischer Gefahrenhinweis:** Entfernen sie nicht beliebig komponenten des 7100G-Series, wenn dieser noch an die Stromzufuhr angeschossen ist, gefährliche Spannungen können Personen verletzen oder das Gerät beschädigen.

Schalten Sie den 7100G-Series nicht ein, bevor alle komponente das Gerät abdeckt und mit den Schrauben fixiert wurde.

**Risques d'électrocution:** Ne retirez aucun composant du commutateur lorsque l'appareil est sous tension. Des tensions dangereuses pourraient entraîner des blessures ou endommager l'élément. Actionnez de nouveau le commutateur uniquement une fois que tous les composants et que toutes les vis sont bien en place.





**Warning:** This unit may have more than one power supply cord. Disconnect two power supply cords before servicing to avoid electric shock.

**Advertencia:** Esta unidad puede tener mas de un cable de fuente de poder. Desconectar dos cables de fuentes de poder antes de dar servicio para prevenir riesgo eléctrico.

**Warnhinweis:** Dieses Gerät hat mehrere Netzanschlüsse, trennen Sie vor den Wartungsarbeiten beide Netzanschlüsse vom Versorgungsnetz. zum Schutz vor elektrischen Schlägen.

**Avertissement:** Cet élément pourrait avoir plus d'un câble d'alimentation. Déconnectez tous les câbles d'alimentation avant d'effectuer les opérations de maintenance sur l'appareil afin de réduire les risques d'électrocution.

## Required Tools

Use the following tools to perform the procedure provided in this appendix:

- ESD wrist strap
- Phillips screwdriver capable of extending 6 or more inches into the unit
- Flash light (recommended)



**Caution:** An antistatic wrist strap is required to perform the procedures in this appendix. Use the antistatic wrist strap to minimize ESD damage to the devices involved.

**Precaución:** Para llevar a cabo los procedimientos especificados en el apéndice deberá utilizar una pulsera antiestática. Esta pulsera sirve para minimizar los efectos de las descargas de electricidad estática.

## About the Mode Switches



**Caution:** Read the appropriate sections to be fully aware of the consequences when changing switch settings.

Only qualified personnel should change switch settings.

**Precaución:** Si desea modificar la configuración del interruptor, lea las secciones correspondientes para saber cuál será el resultado de hacerlo.

Estas modificaciones a la configuración sólo debe realizarlas personal calificado.

Figure B-1 on page B-4 shows the locations of the mode switches and the switch settings for normal operation. These switches are set at the factory and rarely need to be changed. Switches are numbered 1 through 8 from left to right.

Switch definitions and positions are as follows:

- Switches 1– 6: For Enterasys Networks use only.
- Switch 7: Clear Persistent Data. Changing the position of this switch from the up position to the down position clears persistent data on the next power-up of the 7100G-Series switch. All user-entered parameters, such as the IP address, system name, and so on, are reset to the factory default settings. Once the system resets, you can either use the factory default settings or reenter your own parameters.
- Switch 8: Clear Admin Password. Changing the position of this switch from the up position to the down position clears the admin password, and restores the factory default password on the next power-up of the system. Once the 7100G-Series switch resets, you can either use the factory default setting or reenter your own password.



**Note:** Do not change the position of Switch 8 unless it is necessary to reset the admin password to its factory default setting.

**Figure B-1 Mode Switch Location**

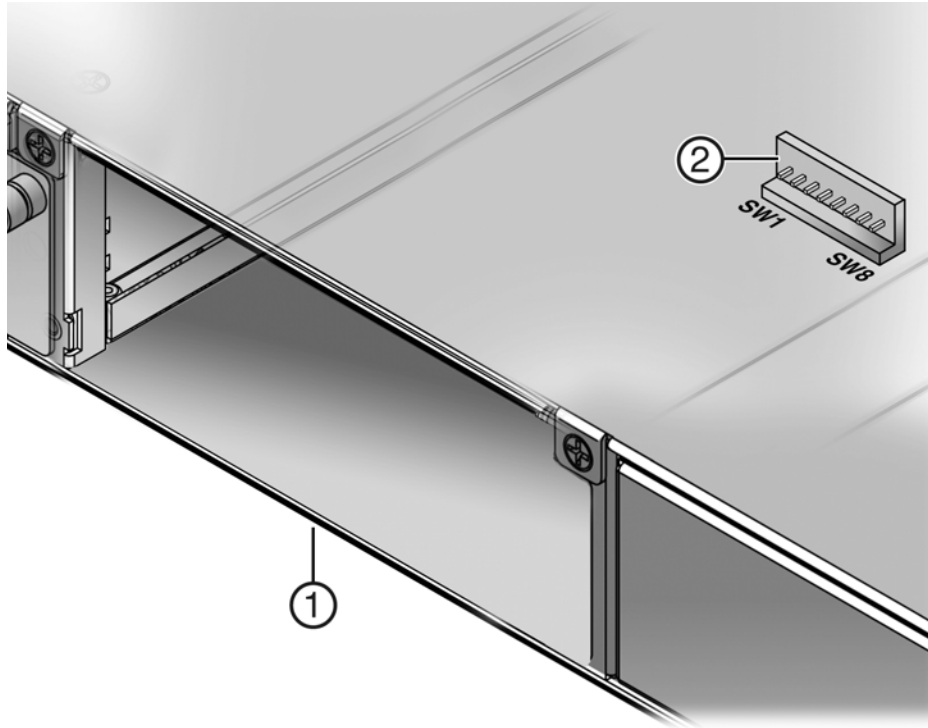

1 Fan Module Bay

2 Mode Switches

## Setting the Mode Switches

Before setting the mode switches, you must power down the 7100G-Series switch.

1. Put on the ESD wrist strap and attach it to the ground receptacle on the switch I/O ports side of the 7100G-Series switch.
2. Remove the fan module from the 7100G-Series switch detailed in steps 1 - 5 of [“Replacing the 7100G-Series Fan Module”](#) on page 3-8.
3. Toggle the appropriate switch to the opposite position relative to its current state.
4. Reinstall the fan module detailed in steps 6 - 8 of [“Replacing the 7100G-Series Fan Module”](#) on page 3-8.



**Note:** Switches 7 and 8 are treated as one time toggle switches. The system looks for a change in position since the last system reset. If the position of switch 7 has changed since the last reset, persistent storage will clear on this reboot. If the position of switch 8 has changed since the last reset, the system password will reset to the default password on this reboot.



## Optional Rack Mount Rail Kit Installation

This appendix describes the installation and use of the optional 7100 Universal Rack Mount Kit, model number 71A-RACK-U. This optional rack mounting kit provides for flexible mounting options in both 4-post and 2-post rack installations.



**Electrical Hazard:** Only qualified personnel should perform installation procedures.

**Riesgo Electrico:** Solamente personal calificado debe realizar procedimientos de instalacion.

**Elektrischer Gefahrenhinweis:** Installationen sollten nur durch ausgebildetes und qualifiziertes Personal vorgenommen werden.

**Risques d'électrocution:** Seul un personnel qualifié doit effectuer les procédures d'installation.

For information about...	Refer to page...
<a href="#">Required Tools</a>	C-1
<a href="#">Contents of Mounting Kit</a>	C-2
<a href="#">Installation Site Requirements</a>	C-2
<a href="#">Required Order of Installation</a>	C-3
<a href="#">Removing the Rack Mount Ears from the 7100G-Series Chassis</a>	C-3
<a href="#">Installing the Adapter Plates</a>	C-3
<a href="#">4-Post Rack Mount Installation</a>	C-5
<a href="#">2-Post Rack Mount Installation</a>	C-7

### Required Tools

- ESD wrist strap (included with the 7100G-Series chassis)
- Phillips screwdriver

## Contents of Mounting Kit

Table C-1 lists the contents of the 71A-RACK-U mounting kit.

**Table C-1 Contents of 71A-RACK-U**

Item	Number
Left and right rails and extensions assemblies	2
Adapter plates	2
Mid-Brackets	2
6-32 flat head screws	6
10-32 pan head screws (black)	2
10-32 cage nuts	2



**Note:** The 71A-RACK-U mounting kit does not include rack screws. You must provide screws or fasteners appropriate to your rack for securing the rails and the 7100G-Series chassis in the equipment rack. Each procedure in this guide specifies the number of rack screws that you must provide.

## Installation Site Requirements

If you plan to cable your 7100G-Series chassis with SFP+ pluggable transceivers, you may need to have 3–4 inches of clearance on the switch I/O port side of the 7100G-Series chassis.

See [Appendix E, Environmental Guidelines](#) for environmental guidelines relating to the 7100G-Series switch installation.

The installation site must be within reach of the network cabling and meet the requirements listed below:

- Appropriate grounded power receptacles must be located within 7 feet of the site.
- A temperature of between 5°C (41°F) and 40°C (104°F) must be maintained at the installation site with fluctuations of less than 10°C (18°F) per hour.



**Caution:** To ensure proper ventilation and prevent overheating, leave a minimum clearance space of 5.1 cm (2.0 in.) at the front and rear of the device.

**Precaución:** Para asegurar una buena ventilación y evitar que el sistema se sobrecaliente, deje un espacio mínimo de 5.1 cm (2 pulgadas) con respecto al anverso y reverso del aparato.



**Warning:** Before rack-mounting the device, ensure that the rack can support it without compromising stability. Otherwise, personal injury and/or equipment damage may result.

**Advertencia.** Antes de montar el equipo en el rack, asegurarse que el rack puede soportar su peso sin comprometer su propia estabilidad, de otra forma, daño personal o del equipo puede ocurrir.

**Warnhinweis:** Überzeugen Sie sich vor dem Einbau des Gerätes in das Rack von dessen Stabilität, ansonsten könnten Personenschäden oder Schäden am Gerät die Folge sein.

**Avertissement:** Avant de monter l'appareil sur le bâti, assurez-vous que l'étagère peut en supporter le poids sans en compromettre la stabilité. Cela pourrait, dans le cas contraire, entraîner des blessures ou des dommages matériels.

For more information about flat surface installation or rack installation using the mounting brackets installed on the 7100G-Series chassis, see [“Installation”](#) on page 2-1.

## Required Order of Installation

1. Remove the rack mount ears from the chassis
2. Attach the adapter plates to the chassis
3. Install the rail assemblies in either a four post rack (see [“4-Post Rack Mount Installation”](#) on page C-5) or a two post rack (see [“2-Post Rack Mount Installation”](#) on page C-7)
4. Install the chassis in the rack.

## Removing the Rack Mount Ears from the 7100G-Series Chassis

Remove the rack mount ears from both sides of the 7100G-Series chassis before continuing with the mounting kit installation. See [Figure C-1](#).

**Figure C-1 Removing the 7100G-Series Chassis Rack Mount Ears**

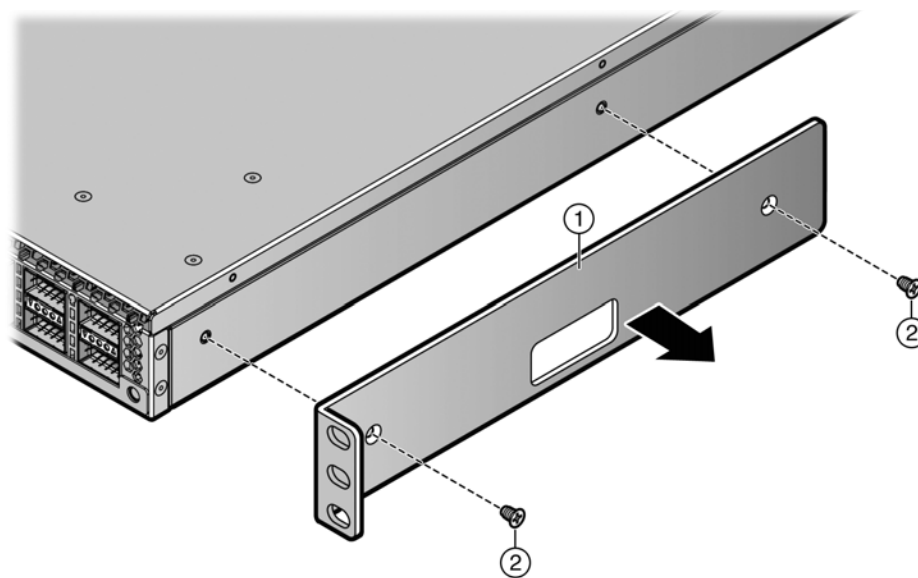

1 Rack mount ear

2 Rack mount ear screws

The removed rack mount ears and screws are not used in any mounting kit installation procedures.

## Installing the Adapter Plates

Two adapter plates come with the mounting kit. Adapter plates are used to secure the chassis to:

- The rail and extension assemblies used in the 4-post rack configuration (see [“Rack Mount Rail with Attached Extension Assembly Installation”](#) on page C-6)
- The rail and mid-bracket assemblies used in the 2-post rack configuration (see [“Pre-Installation Tasks”](#) on page C-8)
- The adapter plates can be installed in either a flush or a recessed configuration of up to 1.5 inch.



**Note:** The side air vents are intentionally covered by the adapter plates in certain mounting configurations. The 7100G-Series switch cooling design is from front to back, not side to side.

The 7100G-Series chassis can be configured for air intake on either the chassis switch I/O port side or the power supply side. Adapter plate installation must align the adapter plate ears with the air intake side of the chassis.

If you have not verified the power supply and fan module air flow for the chassis you are installing, see “[Power Supply Air Flow and Switch Fan Module Air Flow](#)” on page 2-4 for information on determining air flow direction for your chassis before installing the adapter plates.

See “[Reversing the Fan Module Air Flow](#)” on page 2-5 if the current fan module air flow direction does not match the intended chassis air flow direction.

To install the adapter plates:

1. Place the adapter plates on each side of the chassis with the ear end toward the air intake side of the chassis, ear flange pointing away from the chassis. [Figure C-2](#) shows the correct orientation for a chassis with air flow from switch I/O port side to power supply side.
2. Align either the flush mount adapter plate screw holes (Callout 2) or the appropriate recess mount adapter plate screw holes with the three chassis screw holes on each side of the chassis. Callout 3 identifies the screw holes used to recess the chassis by .5, 1.0, or 1.5 inches



**Note:** When recess mounting, use care that the installation does not result in openings above and below the chassis face at the inlet side that allow for hot air recirculation from the exhaust side of the rack or cabinet. This is especially the case for a cabinet with enclosed sides where the cold and hot aisles are meant to be isolated.

3. Insert and tighten three of the six 6-32 flat head screws that come with the mounting kit in three places on each side of the chassis.

**Figure C-2** Installing the Adapter Plates

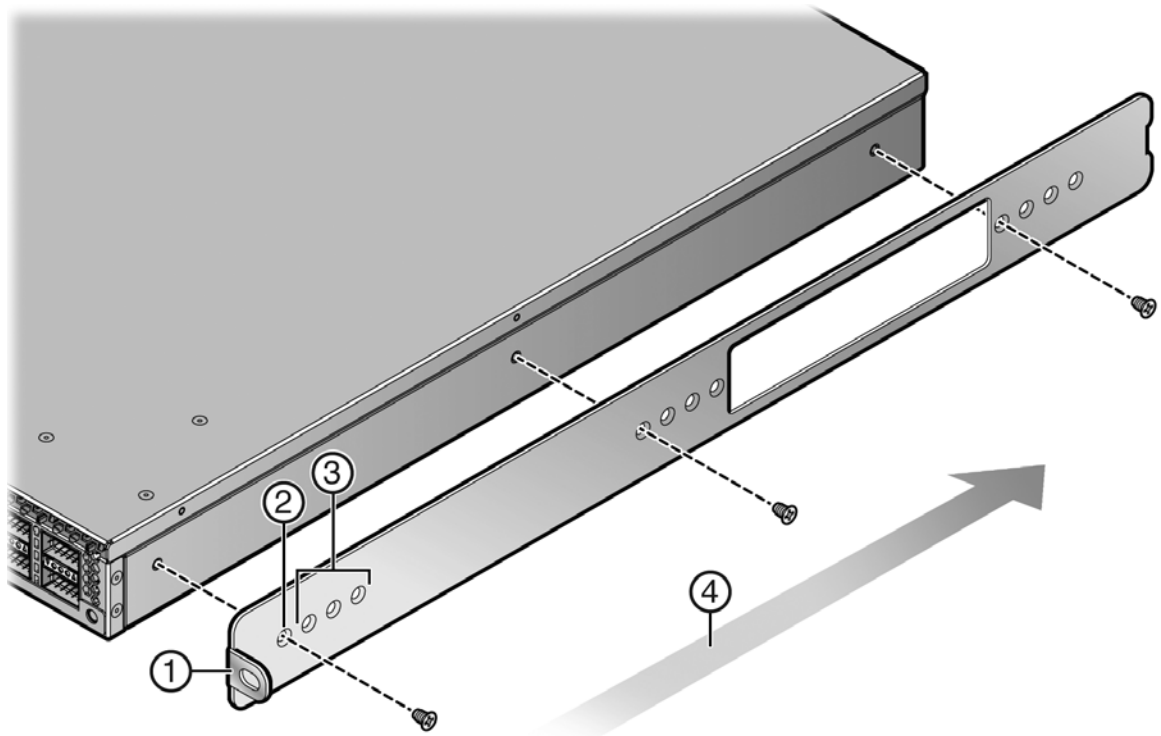

- |   |                                      |   |  |
|---|--------------------------------------|---|--|
| 1 | Adapter plate (ear side)             | 3 | Recess mount adapter plate screw holes (1.5 in.) |
| 2 | Flush mount adapter plate screw hole | 4 | Air flow direction                               |

## 4-Post Rack Mount Installation

The rack mount option kit supports the flush mount configuration for a 4-post rack installation, with the option of recessing the chassis a maximum of 1.5 inches. Both air flow directions are supported.

Figure C-3 on page C-5 displays the 4-post rack flush mount configuration for both air flow directions. The recessed chassis configurations (configured when installing the adapter plates, see “Installing the Adapter Plates” on page C-4) are not displayed.

**Figure C-3 Four Post Rack Supported Configurations**

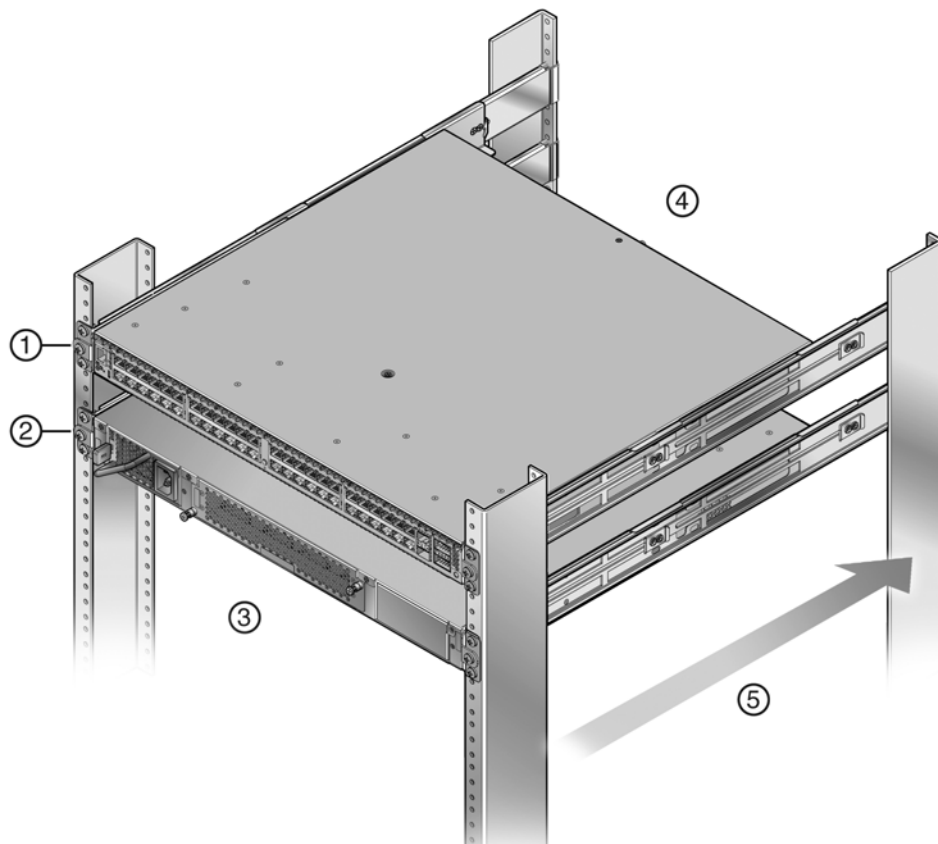

- |   |   |   |                      |
|---|---|---|----------------------|
| 1 | Flush mount, switch I/O port side to power supply side air flow | 4 | Hot air exhaust side |
| 2 | Flush mount, power supply side to switch I/O port side air flow | 5 | Air flow direction   |
| 3 | Cool air intake side  |   |                      |

This section details the installation of the optional rack mount kit for a 4-post rack and covers installing:

- The rack mount rail and extension assembly to the rack
- The 7100G-Series chassis to the rack mount rail and extension assembly

The optional rack mount kit contains two pre-assembled rack mount rails with attached extensions. The length of each assembly is adjustable from 22 inches to 30 inches. Each assembly is labeled either “right front” or “left front”. The front of the rack is always the cool air intake side. The rear of the rack is always the hot air exhaust side.

## Rack Mount Rail with Attached Extension Assembly Installation

Refer to [Figure C-4](#) on page C-6 as you perform the following procedure.

To install the rack mount rail with extension assembly:

1. Adjust the length of the two assemblies (callout 1) to agree with the distance between the outer face of the vertical rack posts. The screws (callout 5) holding the assembly together may need to be loosened slightly to allow for the adjustment. Retighten any loosened screws once the adjustment has been made.
2. Install the side of the assembly labeled “right front” (callout 2) on the front (cool air inlet) right rack post. Secure the assembly to both the front and rear posts, using rack appropriate screws or fasteners that you supply.

Do not use the middle hole when securing the assembly to the rack post. The middle hole is used to secure the adapter plate (previously installed on the chassis) to the assembly.

3. Repeat Step 2 for the assembly labeled “left front”.

**Figure C-4** Installing the Rack Mount Rail with Extension Assemblies

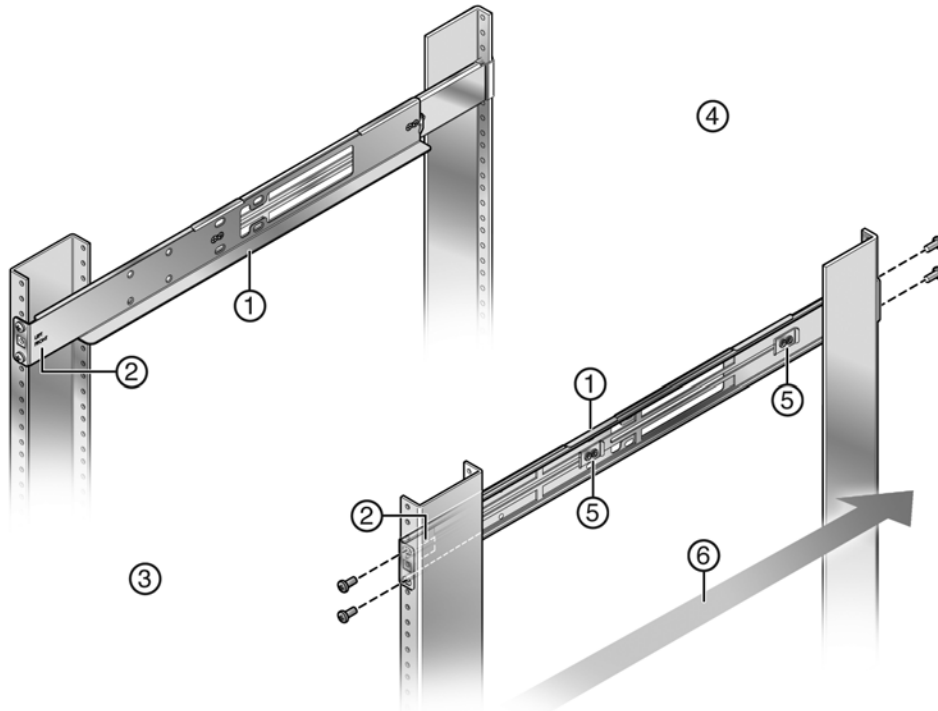

- |   |  |   |                                 |
|---|--|---|---------------------------------|
| 1 | Rack mount rail with extension assembly  | 5 | Rail assembly adjustment screws |
| 2 | Right/left front assembly label location | 6 | Air flow direction              |
| 3 | Rack front (cool air inlet)              | 7 | Rack specific screws (8)        |
| 4 | Rack rear (hot air outlet)               |   |                                 |

## Chassis to Rail Assembly Installation

Refer to [Figure C-5](#) on page C-7 as you perform the following procedure.

To install the chassis into the rail assembly:



1. Face the front (cool air) side of the rack (callout 1) with the air intake side of the chassis (callout 2) facing you.
2. Slide the chassis with the installed adapter plates onto the rack mount rails until the adapter plate ear (callout 3) meets the middle screw hole (callout 4) of the rack mount rail.
3. Secure the chassis with one screw or fastener appropriate to your rack in each of two adapter plate ear screw holes.

A flange (callout 6), towards the back of each rail assembly secures the back side of the chassis adapter plate in place. If needed, loosen the two screws (callout 8) that secure the rear of the rail assembly to the rack and adjust the rail assembly position for best fit or alignment. Retighten the two screws.

**Figure C-5 Installing the Chassis on to the Rack Mount Rail Assembly**

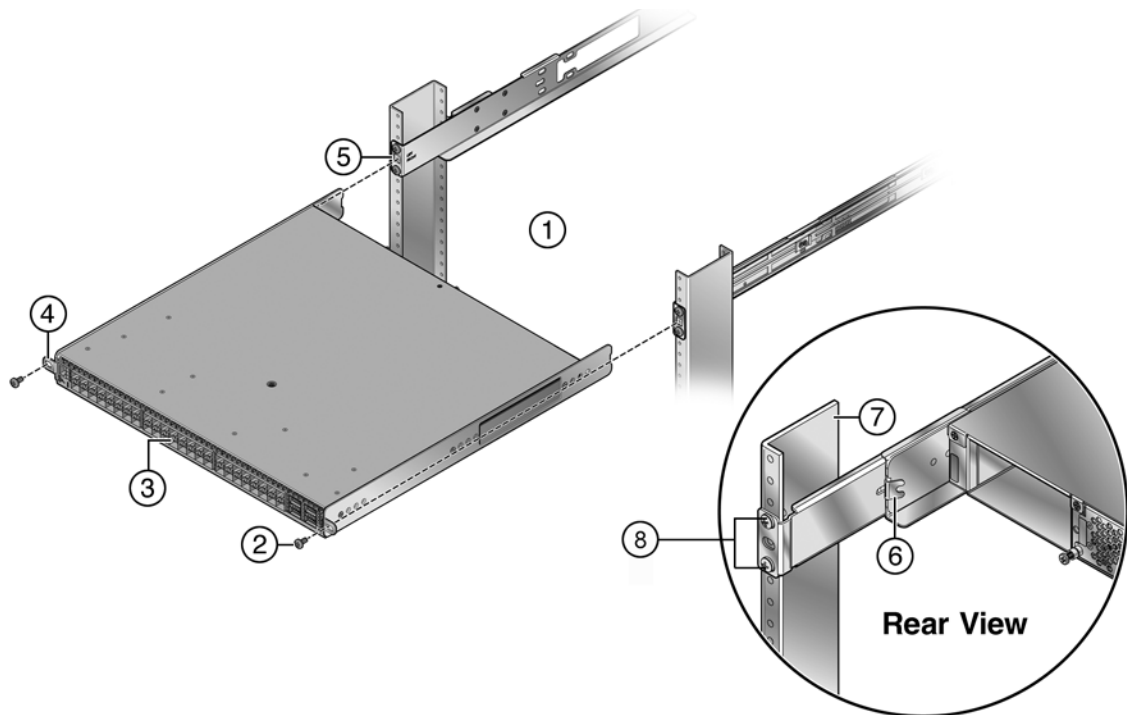

- |   |                             |   |                                 |
|---|-----------------------------|---|---------------------------------|
| 1 | Rack front (cool air inlet) | 5 | Rail assembly middle screw hole |
| 2 | Rack specific screw (2)     | 6 | Rail assembly flange            |
| 3 | Chassis air intake side     | 7 | Rear rack post                  |
| 4 | Adapter plate ear           | 8 | Rail assembly to rack screws    |

## 2-Post Rack Mount Installation

The rack mount option kit supports two configurations for a 2-post rack installation:

- A 3 inch or 7.25 inch post flush mount configuration
- A mid-mount configuration

The option of recessing the chassis up to 1.5 inches is also supported for each configuration (see [“Installing the Adapter Plates”](#) on page C-3). Both air flow directions are supported.

[Figure C-6](#) on page C-8 displays the 2-post rack flush mount and mid-mount configurations for supported air flow directions for a 3 inch post installation. The same configurations apply to a 7.25 inch post installation. The recessed chassis configurations are not displayed.

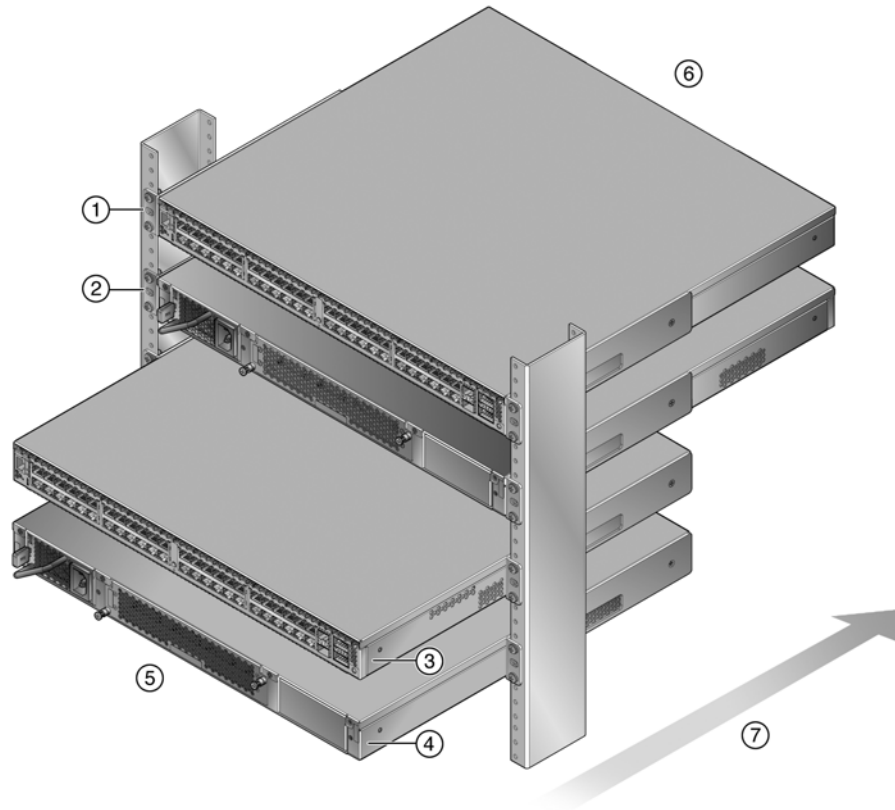
**Figure C-6 Two Post Rack Supported Configurations**

- |   |                        |
|---|------------------------|
| 1 Flush mount, switch I/O port side to power supply side air flow | 5 Cool air intake side |
| 2 Flush mount, power supply side to switch I/O port side air flow | 6 Hot air exhaust side |
| 3 Mid-mount, switch I/O port side to power supply side air flow   | 7 Air flow direction   |
| 4 Mid-mount, power supply to switch I/O port side air flow        |                        |

This section details the installation of the optional rack mount kit for a 2-post rack, including:

- Preparing the rack mount rail assembly for a 2-post rack installation, by removing the extension from the rail assembly and adding a mid-bracket to the rail
- Securing the rack mount rail and mid-bracket assembly to the rack post

## Pre-Installation Tasks

This section details the tasks required before installing in a 2-post rack. The rack mount kit rail assembly is pre-assembled for a 4-post rack installation. Before installing the rail to a 2-post rack:

- Remove the extension from each rack mount kit rail with extension assembly as described in [“Rack Mount Rail Assembly Extension Removal”](#) on page C-8.
- Install a mid-bracket in either a flush or mid-mount configuration to each rail as described in [“Mid-Bracket to Rail Assembly”](#) on page C-9.

### Rack Mount Rail Assembly Extension Removal

To remove the extension (callout 1) from the rack mount rail assembly, unscrew two screws from each of two assembly clips (callout 4) as shown in [Figure C-7](#).

Retain the four screws (callout 3) from both mount rail assemblies for securing the mid-bracket to the rail (callout 2). Both the extensions and the assembly clips are not used for a 2-post rack installation.

**Figure C-7 Removing the Extension from the Rack Mount Rail Assembly**

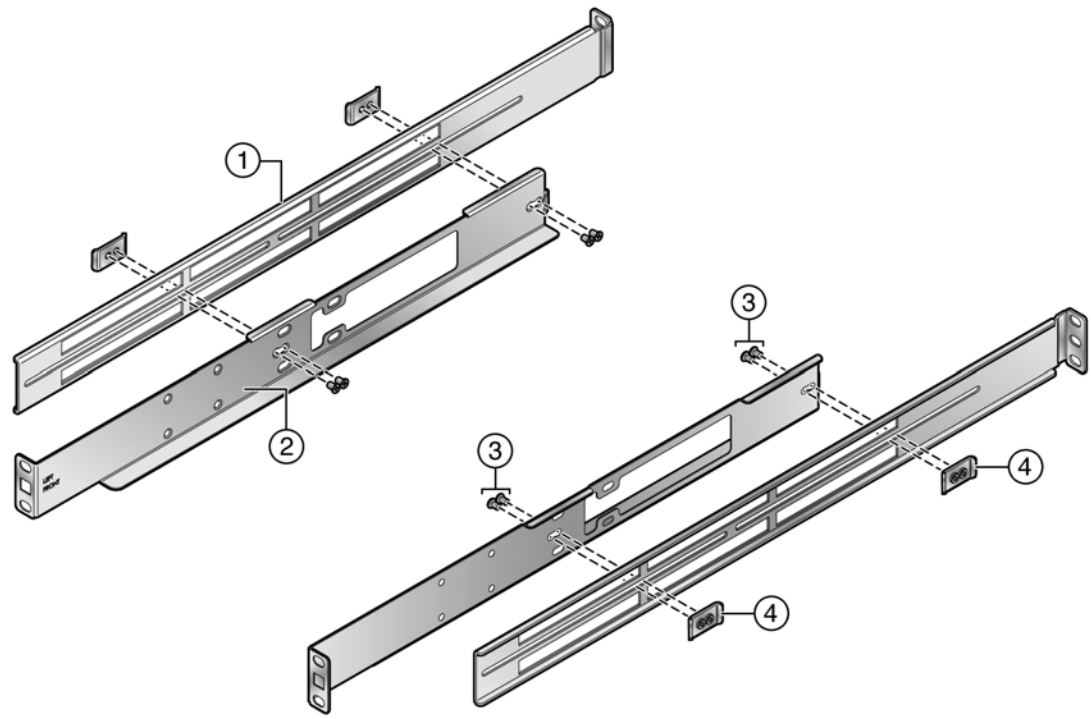

- |   |                                    |   |  |
|---|------------------------------------|---|--|
| 1 | Rack mount rail assembly extension | 3 | Rail assembly clip screws (4 per assembly) |
| 2 | Rack mount rail                    | 4 | Rail assembly clips (2 per assembly)       |

## Mid-Bracket to Rail Assembly



**Note:** The rack post must have holes on both the front and rear flanges to properly secure the rack mount rail in either a 3 inch or 7.25 inch flush 2-post rack configuration. The rack post must have holes on the front flange to secure the rack mount rail in a mid-mount 2-post rack configuration.

The mid-bracket is used to secure the rack mount rail to the rear flange of the rack post in a flush mount configuration or to the front flange of the rack post in a mid-mount configuration.

The positioning of the mid-bracket ear when secured to the rail can be in one of two configurations:

- 3 inches in from the rack mount rail ear for securing to the rear rack post flange in a 3 inch rack post flush mount configuration
- 7.25 inches in from the rack mount rail ear for securing to the rear rack post flange in a 7.25 inch rack post flush mount configuration or 7.25 inches in from the rack mount rail ear for securing to the front rack post flange for a mid-mount configuration (the rear rack post flange is not used in a mid-mount configuration)

The 2-post rack mount rail can be installed in both a flush mount or mid-mount configuration. In a flush mount configuration, the rack mount rail is secured to both the front and rear flange of either a 3 inch or 7.25 inch rack post.

## Mid-Bracket to Rail 3 Inch Flush Mount Assembly



**Note:** If you are installing the rack mount rail in a flush mount 7.25 inch rack post or a mid-mount configuration, proceed to “[Mid-Bracket to Rail 7.25 Inch Flush Mount or Mid-Mount Assembly](#)” on page C-10, otherwise continue here.

To secure the mid-bracket to the rail for a 3 inch post flush mount assembly:

1. Align the mid-bracket (callout 2) with the four rail holes closest to the rail ear (callout 3) as shown in [Figure C-8](#) for both rails
2. Insert and secure the four screws (callout 1) from the rack mount extension assembly for both rails

**Figure C-8 Securing Mid-Bracket to Rail 3 Inch Flush Mount**

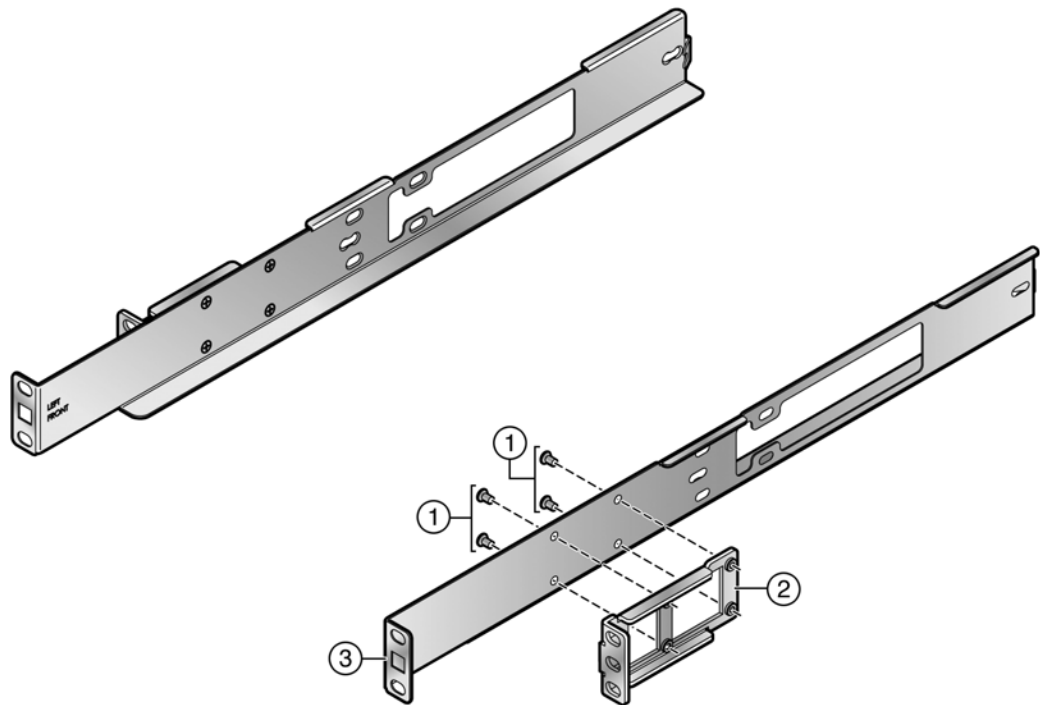

- |   |  |   |          |
|---|--|---|----------|
| 1 | Four screws from extension rack assembly | 3 | Rail ear |
| 2 | Mid-bracket                              |   |          |

## Mid-Bracket to Rail 7.25 Inch Flush Mount or Mid-Mount Assembly

To secure the mid-bracket to the rail for a 7.25 inch post flush mount assembly:

1. Align the mid-bracket (callout 2) with the four rail slots as shown in [Figure C-9](#) on page C-11
2. Insert and secure the four screws (callout 1) from the rack mount extension assembly, allowing some play to adjust the mid-bracket position within the slot space when securing the assembly to the rack post
3. If the assembly will be used in a mid-mount configuration, insert a cage nut (callout 4) that comes with the kit in the rail ear square opening (callout 3)
4. Repeat steps 1–3 for the other rail

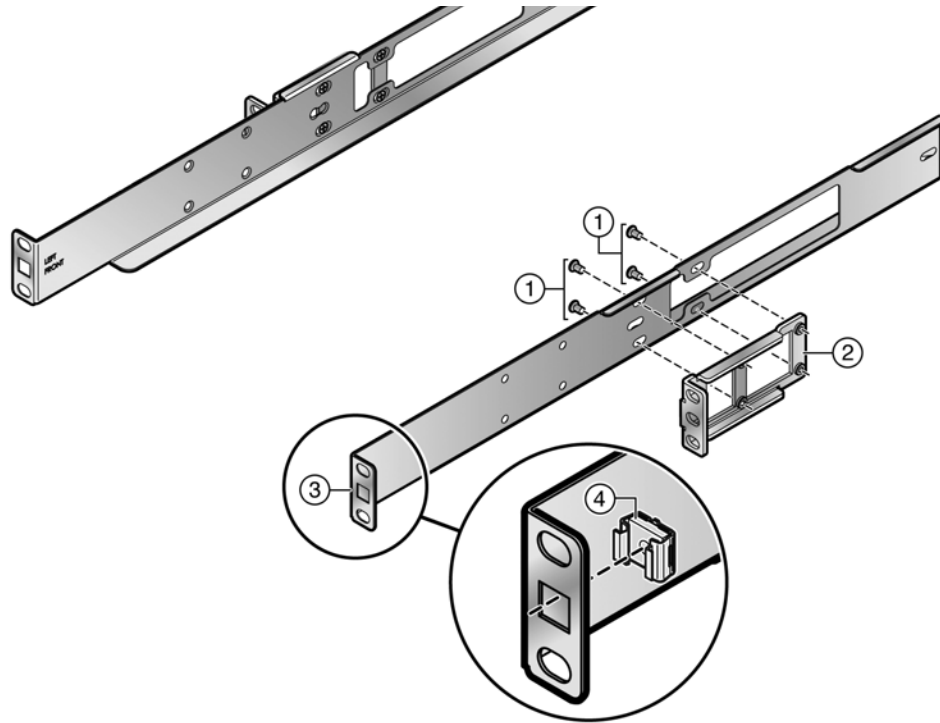
**Figure C-9 Securing Mid-Bracket to Rail 7.25 Inch Flush Mount or Mid-Mount**

- |   |  |   |   |
|---|--|---|---|
| 1 | Four screws from extension rack assembly | 3 | Rail ear square opening                 |
| 2 | Mid-bracket                              | 4 | Cage nut (mid-mount configuration only) |

## Securing the Rail Assembly for a 2-Post Flush Mount Configuration

When securing the rail and mid-bracket assembly in a flush mount configuration:

1. Align the rail ear circular openings with outer front flange rack post openings and the mid-bracket ear openings with outer rear flange rack post openings as shown in [Figure C-10](#) on page C-12
2. Secure each rail assembly with two screws or fasteners appropriate to the rack at both the rail ear and mid-bracket ear

**Figure C-10 Securing a Flush Mount Rail Assembly**

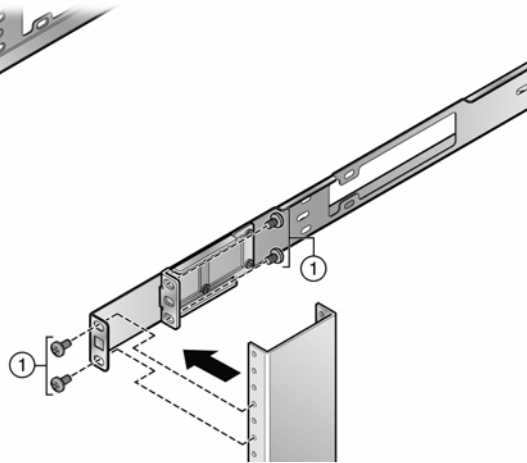

- 
- 1 Rack appropriate screws or fasteners (8)
- 

## Securing the Rail Assembly for a 2-Post Mid-Mount Configuration

When securing the rail and mid-bracket assembly in a mid-mount configuration:

1. Ensure that a cage nut is installed in the rail ear square opening as described in [“Mid-Bracket to Rail 7.25 Inch Flush Mount or Mid-Mount Assembly”](#) on page C-10
2. Align the mid-bracket ear openings with the outer front flange rack post openings as shown in [Figure C-11](#) on page C-13
3. Secure the rail assembly with two screws or fasteners appropriate to the rack at both the rail ear and mid-bracket ear

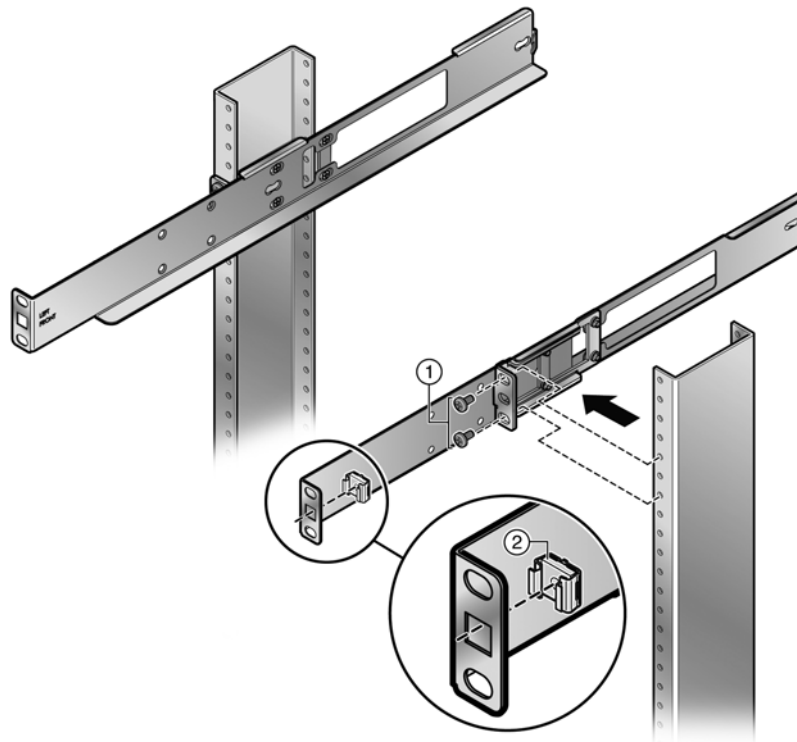
**Figure C-11 Securing Mid-Mount Rail Assembly**

- 1 Rack appropriate screws or fasteners (4)      2 Cage nuts (2)

## Securing the 7100G-Series Chassis to the Rack

To secure the 7100G-Series chassis to the rack:

1. Slide the chassis onto the rail assembly until the chassis adapter plate ears meet the rail assembly ears. See [Figure C-12](#) on page C-14.
2. For a flush mount rail assembly configuration, secure each side of the chassis using a screw or fastener appropriate to your rack that you provide.
3. For a mid-mount rail assembly configuration, secure each side of the chassis using a black, 10-32 screw that comes with the rack mount kit. These screws are screwed into the cage nut installed in the square rail ear opening as described in Step 3 of section “[Mid-Bracket to Rail 7.25 Inch Flush Mount or Mid-Mount Assembly](#)” on page C-10.

**Figure C-12 Securing the 7100G-Series Chassis to the Rack**

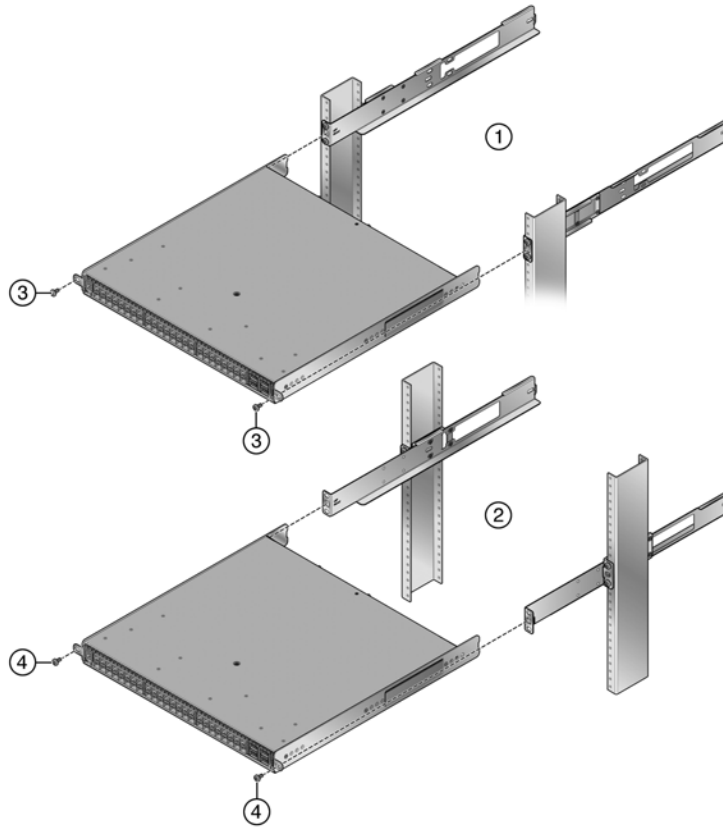

- 
- |                                    |   |
|------------------------------------|---|
| <b>1</b> Flush mount configuration | <b>3</b> Rack appropriate screws or fasteners (2) |
| <b>2</b> Mid-mount configuration   | <b>4</b> Black 10-32 screws (2)                   |
-





## About PoE (Power over Ethernet)

This appendix provides an overview of Power over Ethernet technology and how it is implemented in relation to the 7100G-Series devices.

### Overview

Power over Ethernet (PoE) refers to the ability to provide operational power through the same Ethernet cabling to a PD (powered device) connected to a data network. Modern Ethernet implementations employ differential signals over twisted pair cables. This requires a minimum of two twisted pairs for a single physical link. Both ends of the cable are isolated with transformers blocking any DC or common mode voltage on the signal pair. PoE exploits this fact by using two twisted pairs as the two conductors to supply a direct current. One pair carries the power supply current and the other pair provides a path for the return current. While several proprietary legacy implementations of PoE have been deployed by LAN equipment vendors, in 2003 the IEEE published the IEEE 802.3af-2003 specification, which is part of the 802.3 suite of standards.

The 7100G-Series devices that support PoE are fully compliant with the IEEE 802.3af and 802.3at standards. They support the standard resistor-based detection method, as well as AC disconnect capability.

Each PD has a PDC (Powered Device Classification) that is transmitted to the device for power management purposes. [Table D-1](#) lists the classifications and the associated power ranges based on the 802.3af standard. This table will be updated with 802.3at class information when the 802.3at draft is ratified.

**Table D-1 Powered Device Classifications**

Class	Usage	PD Maximum Power Range Usage
0	Default	0.44 to 12.95 Watts
1	Optional	0.44 to 3.84 Watts
2	Optional	3.84 to 6.49 Watts
3	Optional	6.49 to 12.95 Watts
4	Not Allowed	Reserved for Future Use

### Proprietary PD Detection

7100G-Series devices support a subset of the currently deployed proprietary PoE methods. This includes support for Cisco PDs, including a proprietary capacitor based detection scheme.

## PoE Port Status LEDs

The PoE port status of each 10/100/1000 Mbps RJ45 port is indicated by the two-color RX and TX LED display for each port. To observe the PoE port status indications, you must switch the device from the default RX/ TX status mode to the PoE Port status mode using the red PoE button. PoE status will be displayed on port LEDs for approximately 30 seconds and then returns to link status display mode as described in section “LEDs” on page 3-1.

**Table D-2 PoE LED Status**

Rx LED	Tx LED	Description
Green	Off	Port is delivering power.
Amber	Off	Connected device is requesting power.
Off	Amber	Connected device has exceeded power limit or faulted.
Off	Off	No PoE on port.

## Allocation of PoE Power to Devices

The 7100G-Series firmware determines the power available in the device for PoE based on power supply status and power supply redundancy mode. The system calculates and reserves the correct amount of power required by the device and then makes the balance of power available for PoE. When any change is made to the power supply status or redundancy mode, the firmware recalculates the power available for PoE.

The power available for PoE is distributed based on the configured allocation mode:

- **Automatic** mode (default), in which available power is distributed evenly. Any change in available power, due to a change in power supply status or redundancy mode, will trigger an automatic redistribution of power.
- **Manual** mode, in which the power budget is manually configured, using either CLI commands or the MIBs. The wattage configured cannot exceed the total power available on the switch for PoE.

The configured wattage assignment is used to calculate the total available PoE power. If the total available PoE power changes, a redistribution of available power will occur, applying the calculated percentage.

If the PoE power needed or requested exceeds the power available, the system will generate an SNMP trap to notify the system manager.

For more information on configuring allocation mode, see the *Enterasys 7100G-Series CLI Reference Guide*.

## Power Distribution Upon Power Supply Removal or Addition

When a power supply is removed, the device responds to the decrease in available power by doing the following:

1. Detecting the power supply removal and recalculating available power.
2. Subtracting the power capacity for its base system from available power.
3. Distributing remaining power equally for PoE.
4. Dropping support to PoE devices as necessary to stay within the programmed maximum power.

When a power supply is added, the device responds to the increase in available power by doing the following:

1. Detecting the power supply addition and recalculating available power.
2. Subtracting the power capacity for its base system from available power.
3. Distributing remaining power equally for PoE.

## Management of PoE Power to PDs

You can configure how the device makes power available to attached powered devices (PDs):

- **Real-time** mode (default), in which the PoE controller calculates the power needed by a PD based on the actual power consumption of the attached devices.
- **Class** mode, in which the PoE controller manages power based on the IEEE 802.3at definition of the class limits advertised by the attached devices. In this mode, the maximum amount of power required by a device in the advertised class is reserved for the port, regardless of the actual amount of power being used by the device.

For more information on configuring power management mode, see the *Enterasys 7100G-Series CLI Reference Guide*.





---

## ***Environmental Guidelines***

Enterasys Networks provides high quality and reliable products. To ensure customer satisfaction and the continued reliable operation of our products, installation and operation must comply with the environmental guidelines as described in our product documentation. This document references limits on operating temperature and humidity. Failure to operate the equipment in these prescribed ranges can result in reduced performance and damaged equipment. Failure to comply with these limits and guidelines may void the product warranty and it may also exclude the equipment from support entitlements of any applicable maintenance contract agreements. The following information describes these limits and recommendations in further detail.

### **Temperature and Humidity Guidelines**

#### **Operating Temperatures**

All equipment must operate within the prescribed temperature and humidity ranges specified in Enterasys documentation. Operation of the equipment outside these limits may result in damaged equipment and/or reduced performance and reliability. This may require reliable, monitored and 24x7 operation of climate control systems (heating and air conditioning).

#### **Inlet Air Temperature Measurement**

Operating temperature maximums and minimums are limits on the ambient air temperature entering the switching equipment. This area is located within 1 inch of the main equipment inlet. This is not necessarily the same air temperature throughout the room.

#### **Cooling Air**

Careful consideration is needed when mounting this equipment. Proper inlet and exit spaces must be allowed to get fresh, cool air into the equipment and to allow hot exhaust air to exit away from the equipment. Blocked venting can result in an overheating condition that can damage the equipment. Pay close attention to cable ingress and egress routing to verify that cabling is not blocking venting.

#### **Power Conditioning**

Enterasys products are rated to be used with internationally accepted AC input parameters. It is important that these parameters are monitored and verified to operate as expected for the ratings that apply to the equipment installed. Surges and excessive noise outside of these prescribed ranges in the power circuits feeding this equipment may cause permanent damage to the equipment installed and must be monitored and prevented.

## Airflow Concerns for Closed Racks



**Note:** The 7100G-Series switch directs air flow from front to back, not side to side.

When placing Enterasys switches into enclosed racks, rack exhaust fans must be considered if the rack does not contain adequate inlet and exit venting. These fans may be needed to help exhaust hot air from the rack. They must be sized properly to exhaust the collective volumetric flow from all equipment within the rack.

Figure E-1 illustrates the ideal configuration for a fully vented closed rack. All panels are vented, and side-to-side cooled sub-systems are flowing in the same direction.

Cool air ingress through the bottom of the rack must be carefully allowed to enhance overall system airflow and prevent stagnant air recirculation. This may need to be confirmed through thermal testing at the installation site.

**Figure E-1 Closed Rack Ideal Configuration**

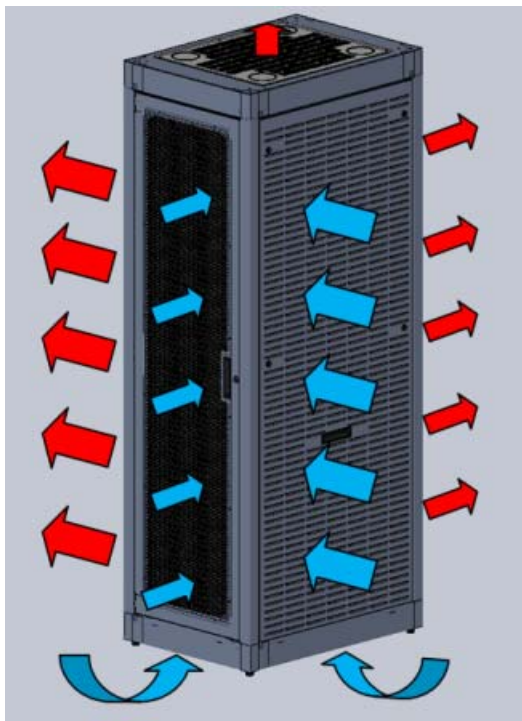

Figure Key	
	Blue arrows indicate cool air ingress
	Red arrows indicate hot air egress
	White arrows indicate airflow through the system

## Airflow Concerns for Open Racks



**Note:** The 7100G-Series switch directs air flow from front to back, not side to side.

Equipment with different air flow cooling patterns, such as front to back or side to side, can present special concerns. Recirculation of heated air through equipment is unwanted because it increases the inlet temperature which causes the equipment components to operate at elevated temperatures. Likewise, equipment in neighboring racks must be planned to prevent hot air exhaust from one system being pulled into the inlet of an adjacent system.

Figure E-2 illustrates the ideal configuration for an open rack. All sub-systems flow in the same direction, as shown by the white arrows.

**Figure E-2 Open Rack Ideal Configuration**

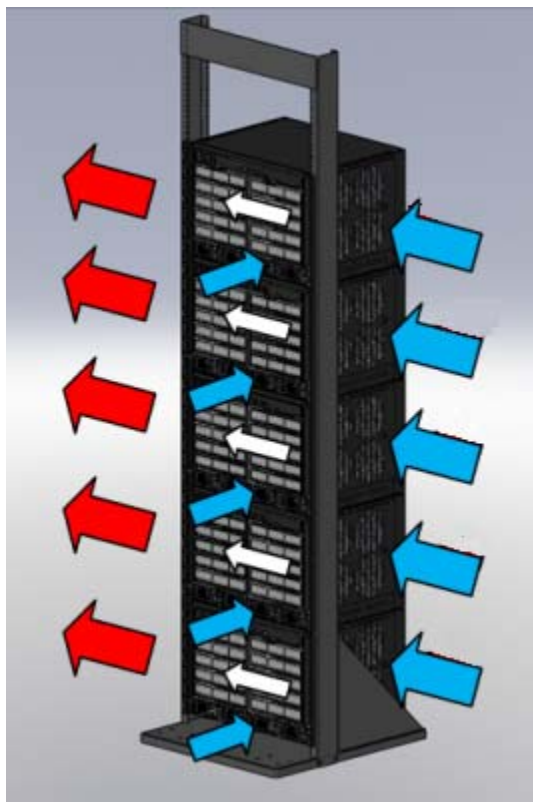
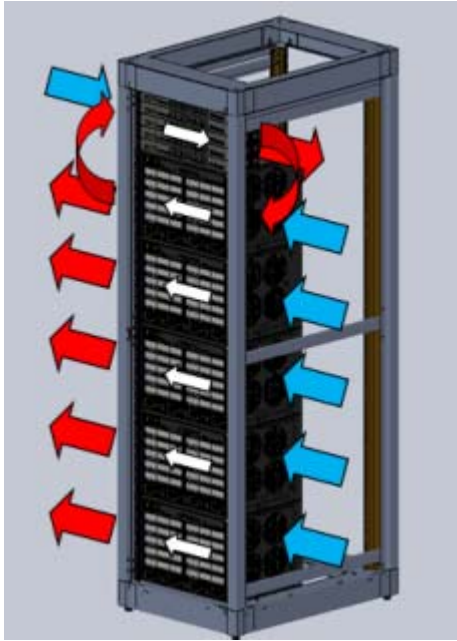

Figure E-3 on page E-4 below shows a non-ideal configuration for an open rack, where sub-systems with mixed flow directions (white arrows) are combined in one rack. Circular red arrows show potential for hot air recirculation.

**Figure E-3 Non-ideal Open Rack Configuration**



Non-ideal flows should be avoided or mitigated and confirmed through thermal testing.

Figure E-4 below shows a non-ideal open rack configuration containing sub-systems with mixed flow directions (white arrows). This configuration shows mitigation of potential hot air recirculation by leaving a gap in the rack population.

**Figure E-4 Mitigated Non-ideal Open Rack Configuration**

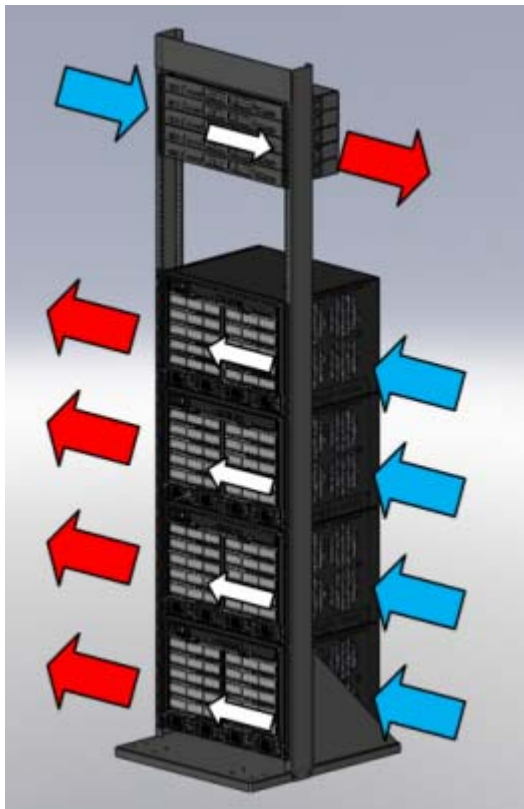
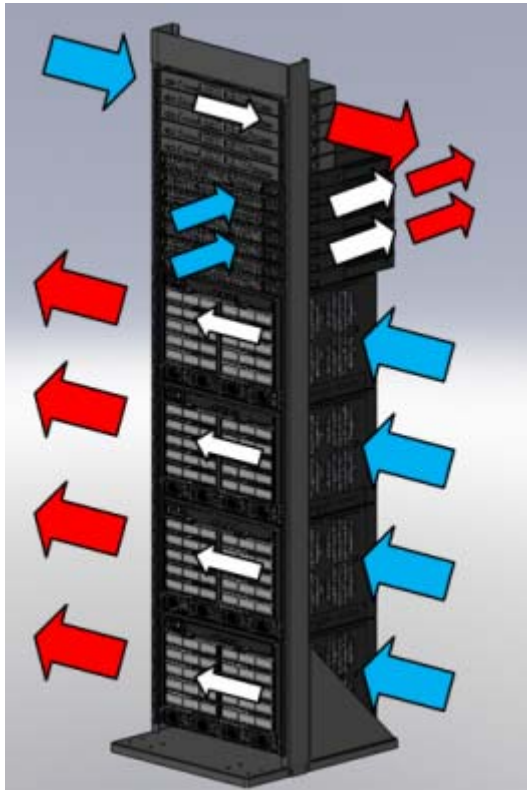



Figure E-5 below shows another mitigation strategy for open racks containing sub-systems with mixed flow direction. Mitigation of potential hot air recirculation is achieved by separating unlike systems with products having front to back airflow patterns.

**Figure E-5 Another Mitigated Non-ideal Open Rack Configuration**



## Dust Mitigation and Prevention

Dust accumulation on inlet and exit venting is not uncommon after prolonged use. In dustier environments this accumulation can be much quicker.

Enterasys strongly recommends routine maintenance to check for clean inlet and exit vents on this equipment. Over time, dust accumulation can create vent blockages, thereby decreasing airflow and increasing component temperatures, resulting in reduced reliability. Recommended maintenance should start with monthly inspections and be adjusted based on dust accumulation levels.

Table E-1 on page E-6 notes the maximum dust and debris accumulation limits for room environments as a reference.

**Table E-1 Airborne Dust Specification for Enterasys Equipment — Airborne Dust Maximum Values**

Dust	Guidelines
All/Total Airborne Particles (TSP-Dichot 15): <sup>1</sup>	20 µg/m <sup>3</sup>
PM10/Coarse Particles (2.5 to 15 microns): <sup>1,2</sup>	Preferred <sup>1</sup> : <10 µg/m <sup>3</sup> Maximum <sup>2</sup> : 20 µg/m <sup>3</sup>
PM2.5/Fine particles (< 2.5 microns): <sup>2</sup>	10 µg/m <sup>3</sup>

1 Value from NEBs GR-63-CORE issue #3 table 4-12.

2 Recommended value by WHO (World Health Organization) for 2005 air quality.

3 TSP-Dichot 15 = Total Suspended Particulates as determined using a Dichotomous sampler with a 15 micron inlet.

4 µg/m<sup>3</sup> = micro grams per cubic meter.

5 Note: The equipment will operate at higher levels than listed above. However, the higher levels can decrease the products' service life.

Dust removal from the equipment is a required part of maintenance. When removing dust:

- Use proper ESD precautions
- Use a vacuum that is properly grounded through a cord having an equipment-grounding conductor and grounding plug

Carefully vacuum the dust particles from the inlet and exit venting of the equipment to allow for proper air flow and ventilation.

Please contact Enterasys Technical Support for additional information about external filter options.

## Airborne Chemicals and Prevention

Various airborne chemicals and contaminants can cause corrosion and thus decrease the service life of most vendors' equipment. To reduce the risk of such corrosion, locate the equipment only in areas that are safe for human occupation.

For more product information and documentation, go to:

<https://extranet.enterasys.com/downloads>