



Avaya Ethernet Routing Switch 4500 Series Regulatory Information

Release 5.3
NN47205-100, 04.03 (322729-C, 02.03)
November 2010

Notice

While reasonable efforts have been made to ensure that the information in this document is complete and accurate at the time of printing, Avaya assumes no liability for any errors. Avaya reserves the right to make changes and corrections to the information in this document without the obligation to notify any person or organization of such changes.

Documentation disclaimer

Avaya shall not be responsible for any modifications, additions, or deletions to the original published version of this documentation unless such modifications, additions, or deletions were performed by Avaya. End User agree to indemnify and hold harmless Avaya, Avaya's agents, servants and employees against all claims, lawsuits, demands and judgments arising out of, or in connection with, subsequent modifications, additions or deletions to this documentation, to the extent made by End User.

Link disclaimer

Avaya is not responsible for the contents or reliability of any linked Web sites referenced within this site or documentation(s) provided by Avaya. Avaya is not responsible for the accuracy of any information, statement or content provided on these sites and does not necessarily endorse the products, services, or information described or offered within them. Avaya does not guarantee that these links will work all the time and has no control over the availability of the linked pages.

Warranty

Avaya provides a limited warranty on this product. Refer to your sales agreement to establish the terms of the limited warranty. In addition, Avaya's standard warranty language, as well as information regarding support for this product, while under warranty, is available to Avaya customers and other parties through the Avaya Support Web site: <http://www.avaya.com/support>. Please note that if you acquired the product from an authorized Avaya reseller outside of the United States and Canada, the warranty is provided to you by said Avaya reseller and not by Avaya.

Licenses

THE SOFTWARE LICENSE TERMS AVAILABLE ON THE AVAYA WEBSITE, [HTTP://SUPPORT.AVAYA.COM/LICENSEINFO/](http://support.avaya.com/licenseinfo/) ARE APPLICABLE TO ANYONE WHO DOWNLOADS, USES AND/OR INSTALLS AVAYA SOFTWARE, PURCHASED FROM AVAYA INC., ANY AVAYA AFFILIATE, OR AN AUTHORIZED AVAYA RESELLER (AS APPLICABLE) UNDER A COMMERCIAL AGREEMENT WITH AVAYA OR AN AUTHORIZED AVAYA RESELLER. UNLESS OTHERWISE AGREED TO BY AVAYA IN WRITING, AVAYA DOES NOT EXTEND THIS LICENSE IF THE SOFTWARE WAS OBTAINED FROM ANYONE OTHER THAN AVAYA, AN AVAYA AFFILIATE OR AN AVAYA AUTHORIZED RESELLER, AND AVAYA RESERVES THE RIGHT TO TAKE LEGAL ACTION AGAINST YOU AND ANYONE ELSE USING OR SELLING THE SOFTWARE WITHOUT A LICENSE. BY INSTALLING, DOWNLOADING OR USING THE SOFTWARE, OR AUTHORIZING OTHERS TO DO SO, YOU, ON BEHALF OF YOURSELF AND THE ENTITY FOR WHOM YOU ARE INSTALLING, DOWNLOADING OR USING THE SOFTWARE (HEREINAFTER REFERRED TO INTERCHANGEABLY AS "YOU" AND "END USER"), AGREE TO THESE TERMS AND CONDITIONS AND CREATE A BINDING CONTRACT BETWEEN YOU AND AVAYA INC. OR THE APPLICABLE AVAYA AFFILIATE ("AVAYA").

Copyright

Except where expressly stated otherwise, no use should be made of materials on this site, the Documentation(s) and Product(s) provided by Avaya. All content on this site, the documentation(s) and the product(s) provided by Avaya including the selection, arrangement and design of the content is owned either by Avaya or its licensors and is

protected by copyright and other intellectual property laws including the sui generis rights relating to the protection of databases. You may not modify, copy, reproduce, republish, upload, post, transmit or distribute in any way any content, in whole or in part, including any code and software. Unauthorized reproduction, transmission, dissemination, storage, and or use without the express written consent of Avaya can be a criminal, as well as a civil, offense under the applicable law.

Third-party components

Certain software programs or portions thereof included in the Product may contain software distributed under third party agreements ("Third Party Components"), which may contain terms that expand or limit rights to use certain portions of the Product ("Third Party Terms"). Information regarding distributed Linux OS source code (for those Products that have distributed the Linux OS source code), and identifying the copyright holders of the Third Party Components and the Third Party Terms that apply to them is available on the Avaya Support Web site: <http://www.avaya.com/support/Copyright/>.

Trademarks

The trademarks, logos and service marks ("Marks") displayed in this site, the documentation(s) and product(s) provided by Avaya are the registered or unregistered Marks of Avaya, its affiliates, or other third parties. Users are not permitted to use such Marks without prior written consent from Avaya or such third party which may own the Mark. Nothing contained in this site, the documentation(s) and product(s) should be construed as granting, by implication, estoppel, or otherwise, any license or right in and to the Marks without the express written permission of Avaya or the applicable third party.

Avaya is a registered trademark of Avaya Inc.

All other trademarks are the property of their respective owners.

Downloading documents

For the most current versions of documentation, see the Avaya Support Web site: <http://www.avaya.com/support>

Contact Avaya Support

Avaya provides a telephone number for you to use to report problems or to ask questions about your product. The support telephone number is 1-800-242-2121 in the United States. For additional support telephone numbers, see the Avaya Web site: <http://www.avaya.com/support>

Contents

Chapter 1: Regulatory information and safety precautions	5
International Regulatory Statements of Conformity	5
National Electromagnetic Compliance (EMC) Statements of Compliance	5
FCC statement (USA only)	5
ICES statement (Canada only)	6
Canadian Department of Communications Radio Interference Regulations	6
Règlement sur le brouillage radioélectrique du ministère des Communications	6
CE marking statement (Europe only)	6
EN 55022 statements	6
EN 55024 statement	6
EN 300386 statement	7
European Union and European Free Trade Association (EFTA) notice	7
VCCI statement (Japan/Nippon only)	7
BSMI statement (Taiwan only)	8
MIC notice (Republic of Korea only)	8
National Safety Statements of Compliance	8
EN 60950 statement	8
NOM statement (Mexico only)	8
Información NOM (unicamente para México)	9
Denan statement (Japan/Nippon only)	10
National Environmental Statement of Compliance	10
Restriction on Hazardous Substances Directive Compliance Statement	10
WEEE Directive Compliance Statement	11
Customer Service	11
Getting technical documentation	11
Getting product training	11
Getting help from a distributor or reseller	11
Getting technical support from the Avaya Web site	12
Getting technical support from the Avaya Web site	12
Notices	12
Avaya Ethernet Routing Switch 4500 Series	13
Chapter 2: Before You Begin	15
New in this release	15
Before you begin	15
Installing the switch on a table or shelf	15
Installing the switch in an equipment rack	17
Power specifications	18
AC power specifications	18
Chapter 3: Deutsche	23
Hinweise zur Verwendung	23
Installation des Switch auf einem Tisch oder Regal	23
Installation des Switch in einem Rack	25
Leistungsdaten	26
Leistungsdaten (Wechselstrom)	26
Wechselstrom-Anschluss	27
Sicherheitsinformationen	29

Chapter 4: Español	31
Antes de comenzar.....	31
Instalación del conmutador en una mesa o estantería.....	31
Instalación del conmutador en un bastidor para equipos.....	33
Especificaciones eléctricas.....	34
Especificaciones eléctricas de CA.....	34
Conexión a CA.....	35
Mensajes de seguridad.....	37
Chapter 5: Français	39
Avant de commencer.....	39
Installation du commutateur sur une table ou sur une étagère.....	39
Installation du commutateur dans un rack.....	41
Alimentation: Caractéristiques.....	42
Alimentation secteur: caractéristiques.....	42
Alimentation secteur: connexion.....	44
Messages de sécurité.....	45
Chapter 6: Português	47
Antes de começar.....	47
Instalação do comutador em uma mesa ou estante.....	47
Instalação do comutador em um rack de equipamento.....	49
Especificações do energia.....	50
Especificações de alimentação CA.....	50
Conexão da alimentação CA.....	52
Mensagens de segurança.....	53

Chapter 1: Regulatory information and safety precautions

Read the information in this section to learn about regulatory conformities and compliance.

International Regulatory Statements of Conformity

This is to certify that the Ethernet Routing Switch 4500 Series equipment was evaluated to the international regulatory standards for electromagnetic compliance (EMC) and safety and were found to have met the requirements for the following international standards:

- EMC – Electromagnetic Emissions – CISPR 22, Class A
- EMC – Electromagnetic Immunity – CISPR 24
- Electrical Safety – IEC 60950, with CB member national deviations

Further, the equipment has been certified as compliant with the national standards as detailed below.

National Electromagnetic Compliance (EMC) Statements of Compliance

FCC statement (USA only)

This equipment has been tested and found to comply with the limits for a Class A digital device, pursuant to Part 15 of the Federal Communications Commission (FCC) rules. These limits are designed to provide reasonable protection against harmful interference when the equipment is operated in a commercial environment. This equipment generates, uses, and can radiate radio frequency energy. If it is not installed and used in accordance with the instruction manual, it may cause harmful interference to radio communications. Operation of this equipment in a residential area is likely to cause harmful interference, in which case users will be required to take whatever measures may be necessary to correct the interference at their own expense.

ICES statement (Canada only)

Canadian Department of Communications Radio Interference Regulations

This digital apparatus (Ethernet Routing Switch 4500 Series) does not exceed the Class A limits for radio-noise emissions from digital apparatus as set out in the Radio Interference Regulations of the Canadian Department of Communications.

Règlement sur le brouillage radioélectrique du ministère des Communications

Cet appareil numérique (le commutateur ERS 4500 Series) respecte les limites de bruits radioélectriques visant les appareils numériques de classe A prescrites dans le Règlement sur le brouillage radioélectrique du ministère des Communications du Canada.

CE marking statement (Europe only)

EN 55022 statements

This is to certify that the Ethernet Routing Switch 4500 Series equipment is shielded against the generation of radio interference in accordance with the application of Council Directive 2004/108/EC. Conformity is declared by the application of EN 55022 Class A (CISPR 22).

EN 55024 statement

This is to certify that the Ethernet Routing Switch 4500 Series are shielded against the susceptibility to radio interference in accordance with the application of Council Directive 2004/108/EC. Conformity is declared by the application of EN 55024 (CISPR 24).

EN 300386 statement

The Ethernet Routing Switch 4500 Series complies with the requirements of EN 300386 V1.3.3 for emissions and for immunity for a Class A device intended for use in either Telecommunications centre or locations other than telecommunications centres given the performance criteria as specified by the manufacturer.

European Union and European Free Trade Association (EFTA) notice

 All products labeled with the CE marking comply with R&TTE Directive (1999/5/EEC) which includes the Electromagnetic Compliance (EMC) Directive (2004/108/EC) and the Low Voltage Directive (2006/95/EC) issued by the Commission of the European Community.

Compliance with these directives implies conformity to the following European Norms (ENs). The equivalent international standards are listed in parenthesis.

- EN 55022 (CISPR 22)–Electromagnetic Interference
- EN 55024 (IEC 61000-4-2, -3, -4, -5, -6, -8, -11)–Electromagnetic Immunity
- EN 61000-3-2 (IEC 61000-3-2)–Power Line Harmonics
- EN 61000-3-3 (IEC 61000-3-3)–Power Line Flicker

VCCI statement (Japan/Nippon only)

This is a Class A product based on the standard of the Voluntary Control Council for Interference (VCCI) for information technology equipment. If this equipment is used in a domestic environment, radio disturbance may arise. When such trouble occurs, the user may be required to take corrective actions.

この装置は、情報処理装置等電波障害自主規制協議会（VCCI）の基準に基づくクラスA情報技術装置です。この装置を家庭環境で使用すると電波妨害を引き起こすことがあります。この場合には使用者が適切な対策を講ずるよう要求されることがあります。

BSMI statement (Taiwan only)

This is a Class A product based on the standard of the Bureau of Standards, Metrology and Inspection (BSMI) CNS 13438 and CNS14336 , Class A.

警告使用者：

這是甲類的資訊產品，在居住的環境中使用時，可能會造成射頻干擾，在這種情況下，使用者會被要求採取某些適當的對策。

MIC notice (Republic of Korea only)

This device has been approved for use in Business applications only per the Class A requirements of the Republic of Korea Ministry of Information and Communications (MIC). This device may not be sold for use in a non-business application.

Observe the Regulatory Marking label on the back or bottom of each switch for specific certification information pertaining to this model. Each Ethernet Routing Switch 4500 Series model is approved for shipment to/usage in Korea and is labeled as such, with all appropriate text and the appropriate MIC reference number.

National Safety Statements of Compliance

EN 60950 statement

This is to certify that the Ethernet Routing Switch 4500 Series equipment is in compliance with the requirements of EN 60950 in accordance with the Low Voltage Directive. Additional national differences for all European Union countries have been evaluated for compliance.

NOM statement (Mexico only)

The following information is provided on the devices described in this document in compliance with the safety requirements of the Norma Oficial Mexicana (NOM):

Exporter: Avaya Inc., 4655 Great America Parkway, Santa Clara, CA 95054 USA.

Importer: Avaya Communication de México S.A. de C.V.
Av. Presidente Masarik 111

Piso 6, Col Chapultepec Morales
Deleg. Miguel Hidalgo
México D.F. 11570

Input:

Ethernet Routing Switch 4500 Series:

- 4548GT-PWR 100-240 VAC 6,5 A MAX 50-60 Hz
- 4550T-PWR 100-240 VAC 6,5 A MAX 50-60 Hz
- 4548GT 100-240 VAC 3 A MAX 50-60 Hz
- 4550T 100-240 VAC 3 A MAX 50-60 Hz
- 4526FX 100-240 VAC 3 A MAX 50-60 Hz
- 4526GTX-PWR 100-240 VAC 6,5 A MAX 50-60 Hz
- 4526GTX 100-240 VAC 3 A MAX 50-60 Hz
- 4526T-PWR 100-240 VAC 6,5 A MAX 50-60 Hz
- 4526T 100-240 VAC 3 A MAX 50-60 Hz
- 4524GT 100-240 VAC 3 A MAX 50-60 Hz
- 4524GT-PWR 100-240 VAC 6,5 A MAX 50-60 Hz

Información NOM (unicamente para México)

La información siguiente se proporciona en el dispositivo o en los dispositivos descritos en este documento, en cumplimiento con los requisitos de la Norma Oficial Mexicana (NOM):

Exportador: Avaya Inc., 4655 Great America Parkway, Santa Clara, CA 95054 USA.

Importador: Avaya Communication de México S.A. de C.V.
Av. Presidente Masarik 111 Piso 6,
Col Chapultepec Morales
Deleg. Miguel Hidalgo
México D.F. 11570

Embarcar a: Ethernet Routing Switch 4500 Series

- 4548GT-PWR 100-240 VAC 6,5 A MAX 50-60 Hz
- 4550T-PWR 100-240 VAC 6,5 A MAX 50-60 Hz
- 4548GT 100-240 VAC 3 A MAX 50-60 Hz
- 4550T 100-240 VAC 3 A MAX 50-60 Hz
- 4526FX 100-240 VAC 3 A MAX 50-60 Hz
- 4526GTX-PWR 100-240 VAC 6,5 A MAX 50-60 Hz
- 4526GTX 100-240 VAC 3 A MAX 50-60 Hz
- 4526T-PWR 100-240 VAC 6,5 A MAX 50-60 Hz

- 4526T 100-240 VAC 3 A MAX 50-60 Hz
- 4524GT 100-240 VAC 3 A MAX 50-60 Hz
- 4524GT-PWR 100-240 VAC 6,5 A MAX 50-60 Hz

Denan statement (Japan/Nippon only)

本製品を安全にご使用頂くため、以下のことにご注意ください。

- 接続ケーブル、電源コード、ACアダプタなどの部品は、必ず製品に同梱されております添付品または指定品をご使用ください。添付品・指定品以外の部品をご使用になると故障や動作不良、火災の原因となることがあります。
- 同梱されております付属の電源コードを他の機器には使用しないでください。上記注意事項を守らないと、死亡や大怪我など人身事故の原因となることがあります。

National Environmental Statement of Compliance

The WEEE Directive 2002/96/EC sets collection, recycling and recovery targets for various categories of electrical products and their waste.

Restriction on Hazardous Substances Directive Compliance Statement

The Restriction on Hazardous Substances Directive (RoHS) (2002/95/EC), which accompanies the WEEE Directive, bans the use of heavy metals and brominated flame-retardants in the manufacture of electrical and electronic equipment. Specifically, restricted materials under the RoHS Directive are Lead (including solder used in PCB's), Cadmium, Mercury, Hexavalent Chromium, and Bromine.

Avaya declares compliance with the European Union (EU) RoHS Directive (2002/95/EC).

WEEE Directive Compliance Statement



This product at end of life is subject to separate collection and treatment in the EU Member States, Norway, and Switzerland and therefore is marked with the symbol shown at the left. Treatment applied at end of life of these products in these countries shall comply with the applicable national laws implementing Directive 2002/96/EC on Waste of Electrical and Electronic Equipment (WEEE).

Avaya declares compliance with the European Union (EU) WEEE Directive (2002/96/EC).

Customer Service

Visit the Avaya Web site to access the complete range of services and support that Avaya provides. Go to www.avaya.com or go to one of the pages listed in the following sections.

Navigation

- [Getting technical documentation](#) on page 11
- [Getting product training](#) on page 11
- [Getting help from a distributor or reseller](#) on page 11
- [Getting technical support from the Avaya Web site](#) on page 12

Getting technical documentation

To download and print selected technical publications and release notes directly from the Internet, go to www.avaya.com/support.

Getting product training

Ongoing product training is available. For more information or to register, you can access the Web site at www.avaya.com/support. From this Web site, you can locate the Training contacts link on the left-hand navigation pane.

Getting help from a distributor or reseller

If you purchased a service contract for your Avaya product from a distributor or authorized reseller, contact the technical support staff for that distributor or reseller for assistance.

Getting technical support from the Avaya Web site

The easiest and most effective way to get technical support for Avaya products is from the Avaya Technical Support Web site at www.avaya.com/support.

Getting technical support from the Avaya Web site

The easiest and most effective way to get technical support for Avaya products is from the Avaya Technical Support Web site at www.avaya.com/support.

Notices

Notice paragraphs alert you about issues that require your attention. The following paragraphs describe the types of notices used in this guide.



Note:

Notes provide tips and useful information regarding the installation and operation of Avaya products.



Electrostatic alert:

ESD

ESD notices provide information about how to avoid discharge of static electricity and subsequent damage to Avaya products.



Caution:

Caution notices provide information about how to avoid possible service disruption or damage to Avaya products.



Warning:

Warning notices provide information about how to avoid personal injury when working with Avaya products.



Voltage:

Danger — High Voltage notices provide information about how to avoid a situation or condition that can cause serious personal injury or death from high voltage or electric shock.



Danger notices provide information about how to avoid a situation or condition that can cause serious personal injury or death.

Avaya Ethernet Routing Switch 4500 Series

The information presented in this document applies to the following products:

- Avaya Ethernet Routing Switch 4548GT
- Avaya Ethernet Routing Switch 4548GT-PWR
- Avaya Ethernet Routing Switch 4550T
- Avaya Ethernet Routing Switch 4550T-PWR
- Avaya Ethernet Routing Switch 4526FX
- Avaya Ethernet Routing Switch 4526GTX-PWR
- Avaya Ethernet Routing Switch 4526GTX
- Avaya Ethernet Routing Switch 4526T-PWR
- Avaya Ethernet Routing Switch 4526T
- Avaya Ethernet Routing Switch 4524GT
- Avaya Ethernet Routing Switch 4524GT-PWR

Chapter 2: Before You Begin

New in this release

One hardware model is added to the Avaya Ethernet Routing Switch 4500 Series in Release 5.3.

The new hardware model is Avaya Ethernet Routing Switch 4524GT-PWR.

Before you begin

Ensure the area where you install and use the 4500 Series switch meets the following environmental requirements:

- Ambient temperature between 32° and 106° F (0° and 50° C)
- Relative humidity between 10% and 90% noncondensing
- No nearby heat sources such as hot air vents or direct sunlight
- No nearby sources of severe electromagnetic noise
- No excessive dust
- Adequate power source within six feet; one 15-Amp circuit required for each power supply
- At least 2 inches (5.08 cm) on each side of the switch unit for ventilation
- Adequate space at the front and rear of the switch for access to cables

If you are installing a single Avaya Ethernet Routing Switch on a table or shelf, ensure the surface can support at least 15 to 20 pounds (7 to 9 kilograms).

Installing the switch on a table or shelf

You can install a single Avaya Ethernet Routing Switch on any flat surface that can safely support the weight of the switch and attached cables (15 to 20 pounds or 7 to 9 kilograms).

The following figures provide instructions for installing the switch on a table or shelf.

Before You Begin

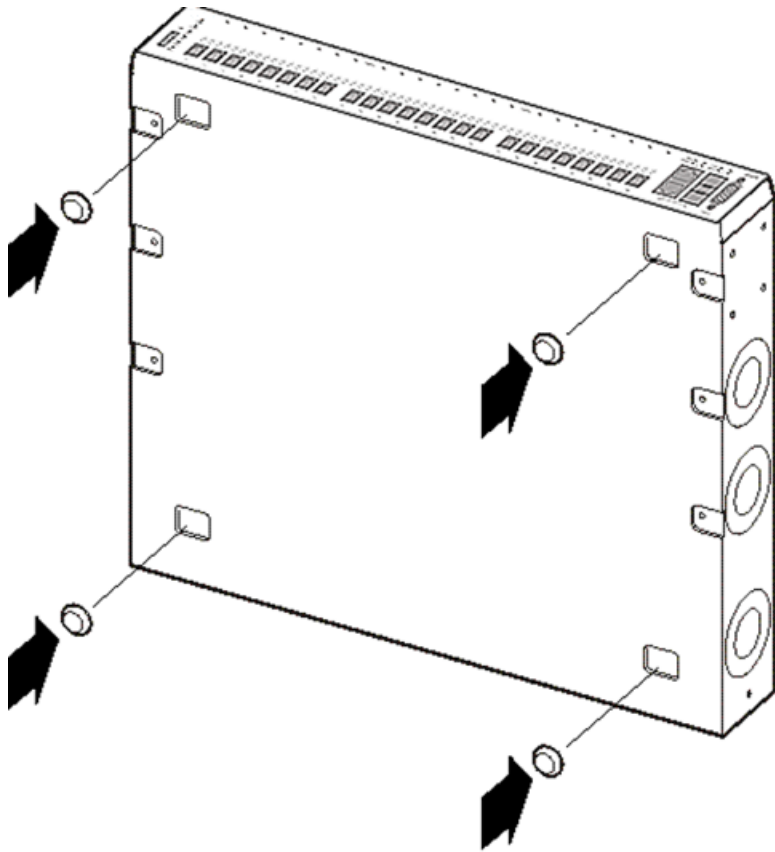

10753FC

Attach the rubber feet at the marked locations.

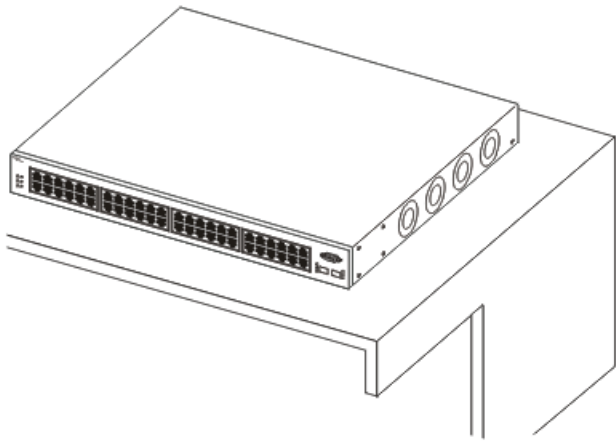

10754FC

Set the switch on a table or shelf.

*** Note:**

Allow at least 2 inches (5.1 cm) on each side for proper ventilation and at least 5 inches (12.7 cm) at the back for power cord clearance.

Installing the switch in an equipment rack

Required tool: Phillips screwdriver for attaching brackets to the switch.

Rack requirements:

A space of 2.8 inches for each switch in an EIA or IEC standard 19 inch (48.2 centimeter) equipment rack.

- The rack must be bolted to the floor and braced, if necessary.
- The rack must be grounded to the same grounding electrode used by the power service in the area. The ground path must be permanent and must not exceed 1 ohm of resistance from the rack to the grounding electrode.

The following figures provide instruction for installing the switch in a rack.

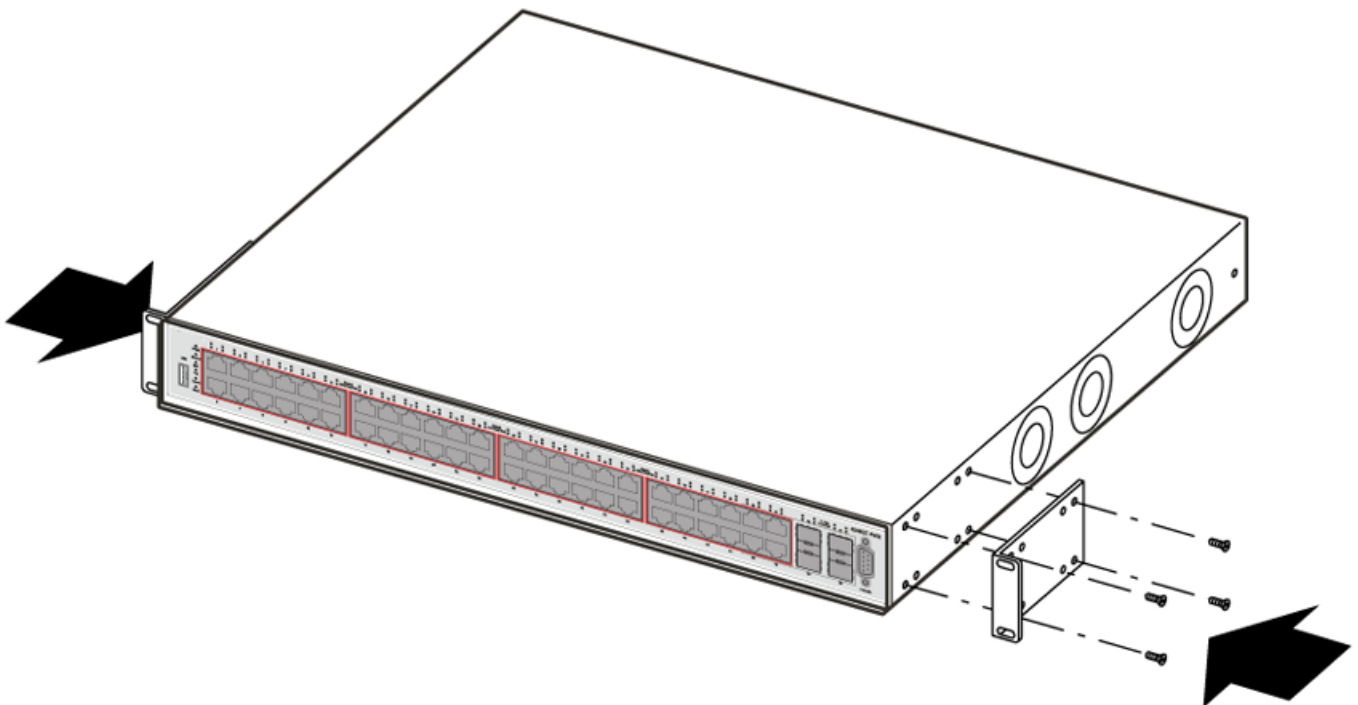

Attach a bracket to each side of the switch.

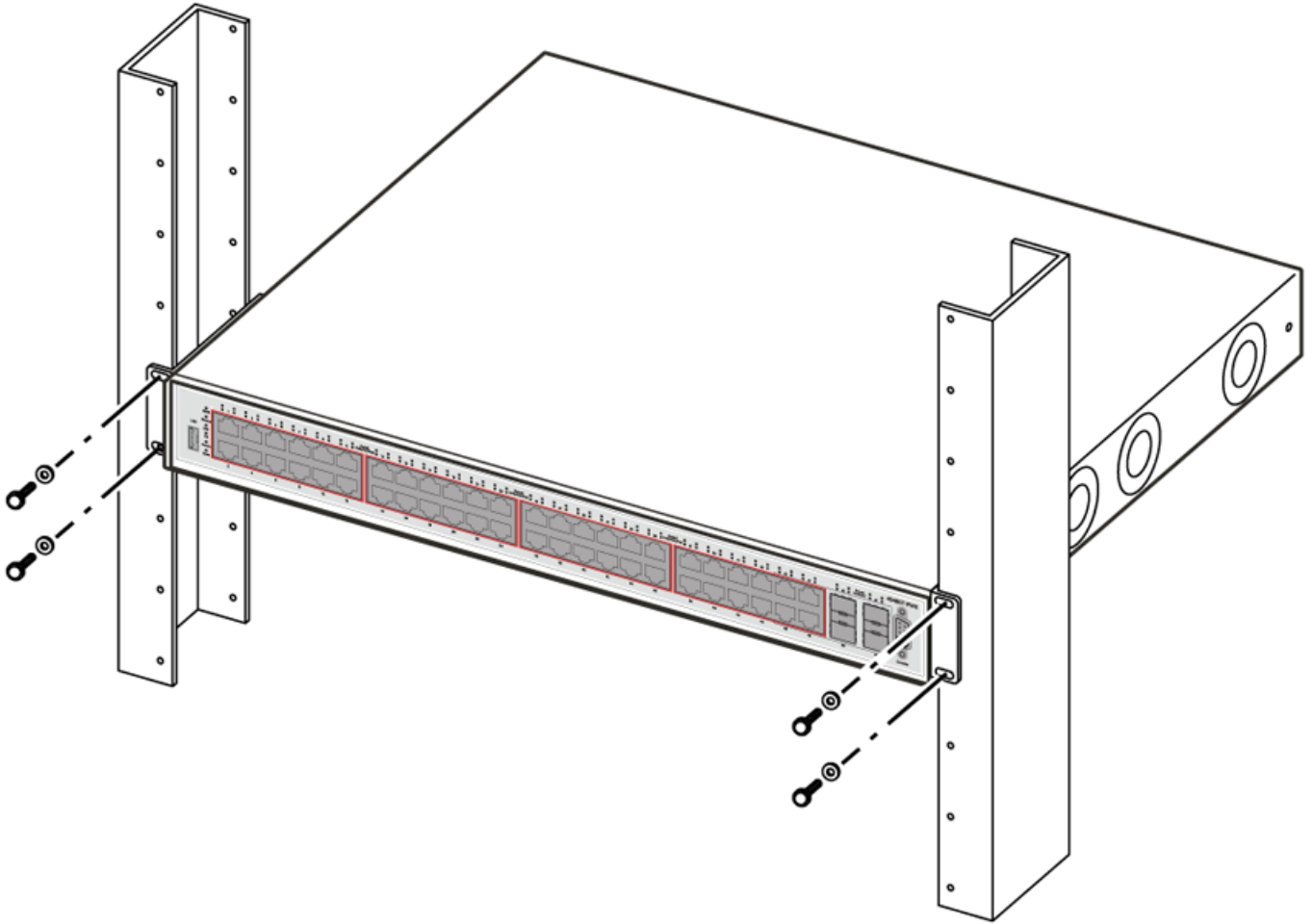

Slide the switch into the rack. Insert and tighten the rack mount screws.

Power specifications

AC power specifications

The following table describes the AC power specifications for the Ethernet Routing Switch 4500 Series.

Model	Input current (amps maximum at 100-120 VAC)	Input current (amps maximum at 200-240 VAC)	Input voltage (rms, VAC at 50-60 Hz)	Input voltage (rms, VAC at 50-60 Hz)	Power consumption (watts maximum)	Thermal rating (Btu/h maximum)
ERS 4548GT	3	1.5	100-120	200-240	150	415
ERS 4548GT-PWR	6.5	3.3	100-120	200-240	470	788
ERS 4550T	3	1.5	100-120	200-240	150	240
ERS 4550T-PWR	6.5	3.3	100-120	200-240	470	615
ERS 4526FX	3	1.5	100-120	200-240	150	256
ERS 4526GTX-PWR	6.5	3.3	100-120	200-240	470	546
ERS 4526GTX	3	1.5	100-120	200-240	150	307
ERS 4526T-PWR	6.5	3.3	100-120	200-240	470	375
ERS 4526T	3	1.5	100-120	200-240	150	188
ERS 4524GT	3	1.5	100-120	200-240	150	290
ERS 4524GT - PWR	6.5	3.3	100-120	200-240	470	478

Connecting AC power

Required cable: AC power cord that meets the requirements of your local electrical code. Refer to [Table 1: International power cord specifications](#) on page 20 for plug specifications.

Table 1: International power cord specifications

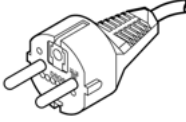
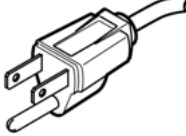
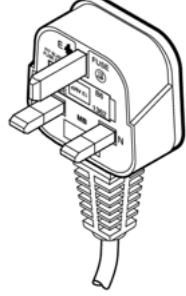
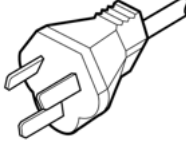
Country and plug description	Specifications	Typical plug
Continental Europe <ul style="list-style-type: none"> • CEE7 standard VII male plug • Harmonized cord (HAR marking on the outside of the cord jacket to comply with the CENELEC Harmonized Document HD-21) 	220 or 230 VAC 50 Hz Single phase	 <p style="text-align: right;">228FA</p>
U.S./Canada/Japan <ul style="list-style-type: none"> • NEMA5-15P male plug • UL-recognized (UL stamped on cord jacket) • CSA-certified (CSA label secured to the cord) 	100 or 120 VAC 50-60 Hz Single phase	 <p style="text-align: right;">227FA</p>
United Kingdom <ul style="list-style-type: none"> • BS1363 male plug with fuse • Harmonized cord 	240 VAC 50 Hz Single phase	 <p style="text-align: right;">229FA</p>
Australia AS3112-1981 male plug	240 VAC 50 Hz Single phase	 <p style="text-align: right;">230FA</p>

The Ethernet Routing Switch 4500 Series does not have a power switch. When you connect the AC power cord to a suitable AC power outlet, the switch powers up immediately.

Connect the AC power cord to the back of the switch, and then connect the cord to a power outlet.

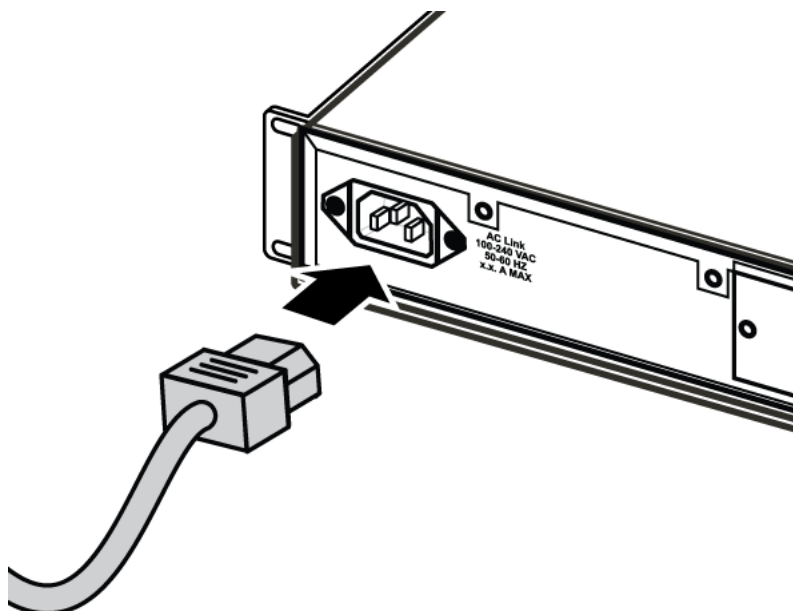

Figure 1: Connecting the AC power cord to the Ethernet Routing Switch 4500 Series

Connect the AC power cord to the back of the switch, and then connect the cord to a power outlet.

Safety messages



Warning:

Installation must be performed by qualified service personnel only. Read and follow all warning notices and instructions marked on the product or included in the documentation.



Voltage:

This equipment relies on the building's installation for overcurrent protection. Ensure that a fuse or circuit breaker no larger than 120 VAC, 15 A U.S. (240 VAC, 16 A International) is used on the phase conductors.



Caution:

This device is a Class A product. In a domestic environment, this device can cause radio interference, in which case the user may be required to take appropriate measures.



Caution:

When mounting this device in a rack, do not stack units directly on top of one another in the rack. Each unit must be secured to the rack with appropriate mounting brackets. Mounting brackets are not designed to support multiple units.

 **Voltage:**

Use only power cords that have a grounding path. Without a proper ground, a person who touches the switch is in danger of receiving an electrical shock. Lack of a grounding path to the switch can result in excessive emissions.

 **Warning:**

Disconnecting the power cord is the only way to turn off power to this device. Always connect the power cord in a location that can be reached quickly and safely in case of an emergency.

 **Warning:**

Fiber optic equipment can emit laser or infrared light that can injure your eyes. Never look into an optical fiber or connector port. Always assume that fiber optic cables are connected to a light source.



 **Caution:**

Risk of explosion if battery is replaced by an incorrect type. Dispose of used batteries according to the instructions.

Chapter 3: Deutsche

Hinweise zur Verwendung

Achten Sie bei der Installation und Verwendung des ERS 4500 Series auf die folgenden äußeren Bedingungen:

- Raumtemperatur zwischen 0° und 50° C
- relative Luftfeuchtigkeit zwischen 10% und 90% (nicht kondensierend)
- keine Hitzequellen, wie z. B. Heizungen oder direktes Sonnenlicht, in unmittelbarer Nähe
- keine elektromagnetischen Störungen in unmittelbarer Nähe
- keine Umgebungen mit starker Staubbildung
- geeignete Stromversorgung nicht weiter als zwei Meter entfernt; für jeden Anschluss wird jeweils ein 15-Amp-Stromkreis benötigt
- mindestens 5 cm Abstand auf beiden Seiten der Schalteinheit für die Belüftung
- ausreichend Platz an der Vorder- und Rückseite der Einheit für Kabelzugriff

Wenn Sie einen einzelnen ERS 4500 Series auf einem Tisch oder Regal installieren möchten, muss die entsprechende Unterlage über eine Tragfähigkeit von mindestens 7-9 kg verfügen.

Installation des Switch auf einem Tisch oder Regal

Sie können einen einzelnen ERS 4500 Series auf jeder ebenen Oberfläche installieren, die das Gewicht des Switch (7-9 kg) und der angeschlossenen Kabel tragen kann.

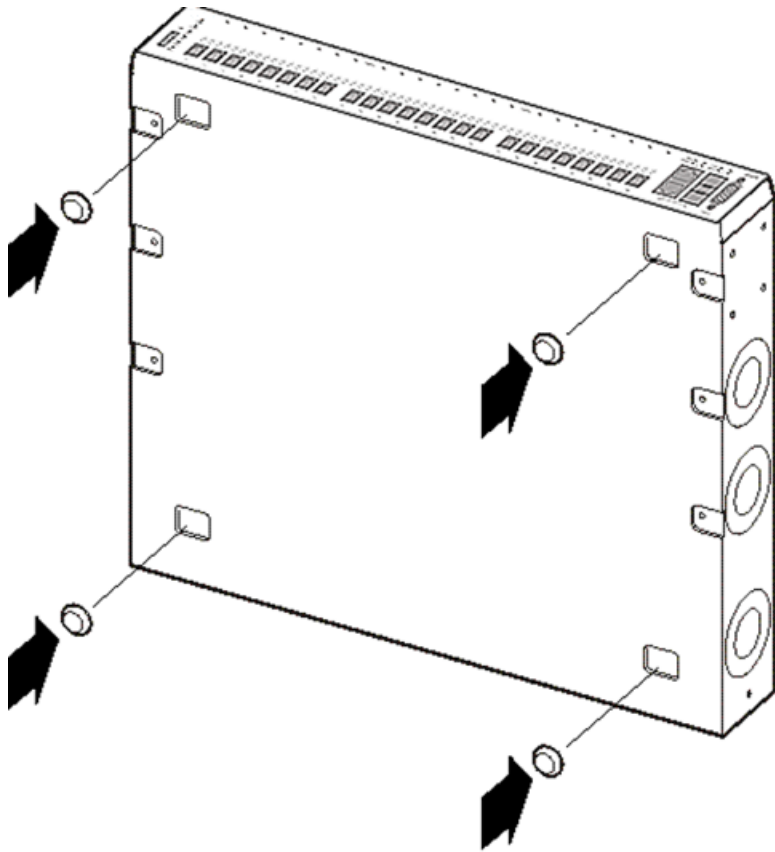

10753FC

Figure 2: Installation des Switch auf einem Tisch oder Regal

Befestigen Sie die GummifüÙe an den angezeigten Stellen.

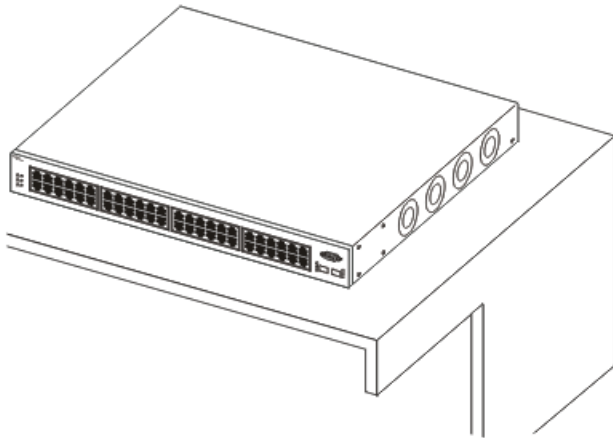

10754FC

Stellen Sie den Switch auf einen Tisch oder Regal.

⚠ Caution:

Hinweis: Lassen Sie an den Seiten des Switch jeweils mindestens 5 cm für ausreichende Belüftung frei und auf der Rückseite mindestens 13 cm, um ausreichend Platz für die Kabel zu gewährleisten.

Installation des Switch in einem Rack

Benötigtes Werkzeug: Kreuzschraubendreher, um die Winkel am Switch zu befestigen

Voraussetzungen für die Installation in einem Rack:

- In einem EIA- oder IEC-Standardrack (19 Zoll) ist für jeden Switch eine Höhe von ca. 7 cm zu berechnen.
- Das Rack muss ggf. am Boden und mit Winkeln an den Seiten verschraubt werden.
- Das Rack muss zu derselben Erdungselektrode geerdet sein, die auch von der Stromversorgung in der Umgebung verwendet wird. Die Erdung muss permanent sein und darf einen Widerstand von 1 Ohm vom Rack zur Erdungselektrode nicht überschreiten.

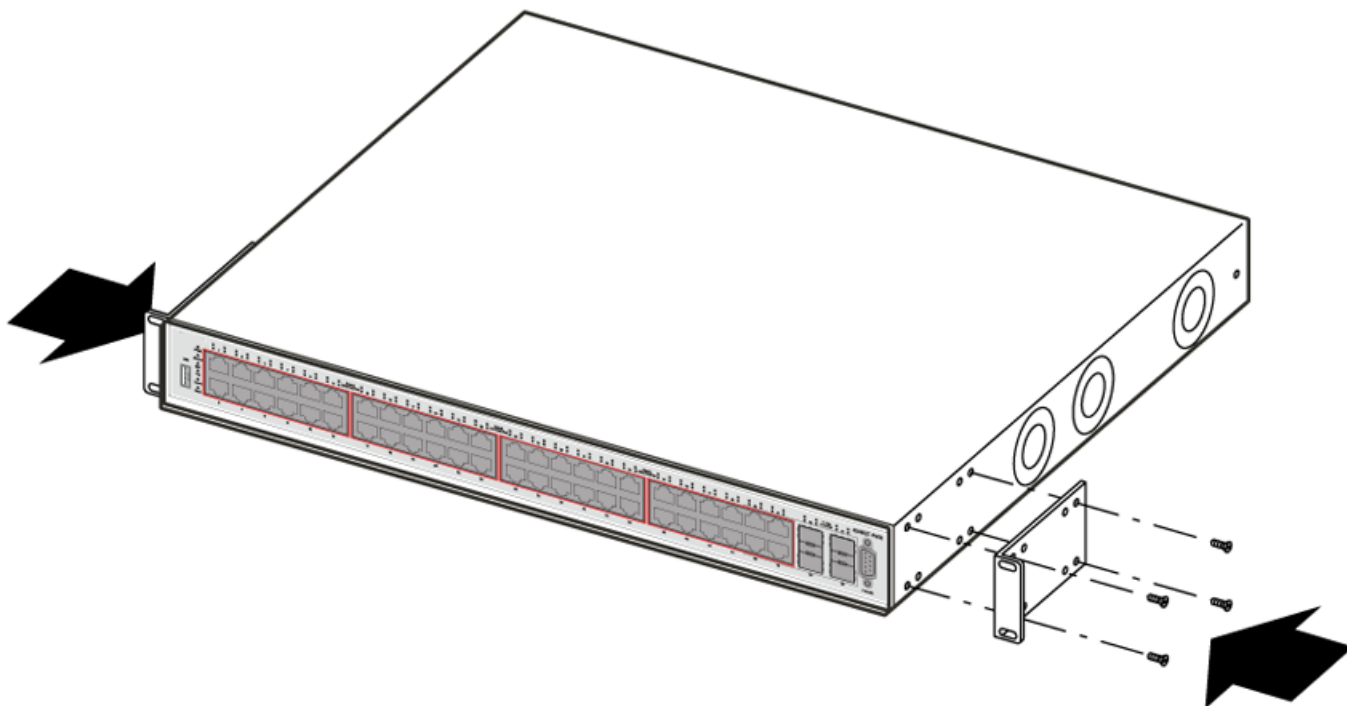
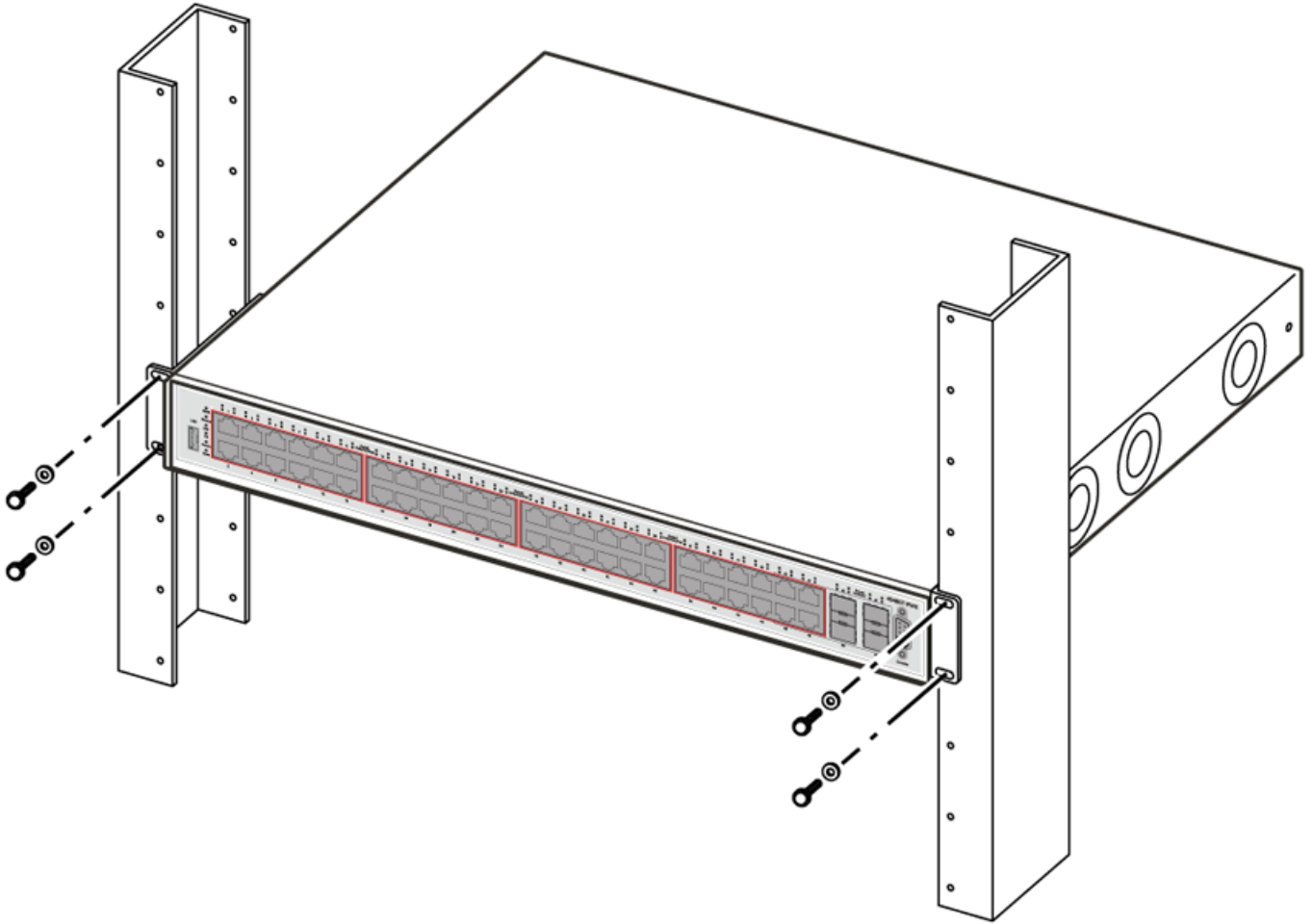

Figure 3: Installation des Switch in einem Rack

Bringen Sie auf jeder Seite des Switch einen Winkel an.



Führen Sie den Switch in das Rack ein. Befestigen Sie den Switch mit den dafür vorgesehenen Schrauben am Rack.

Leistungsdaten

Leistungsdaten (Wechselstrom)

Die folgende Tabelle beschreibt die Wechselstrom-Leistungsdaten für den ERS 4500 Series.

Table 2: Wechselstrom-Leistungsdaten: ERS 4500 Series

Modell	Eingangsstrom max.		Eingangsspannung (Effektivwert)		Energieverbrauch	Thermische Belastbarkeit
	A 100-120 VAC	A 200-240 VAC	V Wechselstrom bei 50-60 Hz		max. W	max. Btu/h
ERS 4548GT	3	1,5	100-120	200-240	150	415
ERS 4548GT-PWR	6,5	3,3	100-120	200-240	470	788
ERS 4550T	3	1,5	100-120	200-240	150	240
ERS 4550T-PWR	6,5	3,3	100-120	200-240	470	615
ERS 4526FX	3	1,5	100-120	200-240	150	256
ERS 4526GTX-PWR	6,5	3,3	100-120	200-240	470	546
ERS 4526GTX	3	1,5	100-120	200-240	150	307
ERS 4526T-PWR	6,5	3,3	100-120	200-240	470	375
ERS 4526T	3	1,5	100-120	200-240	150	188
ERS 4524GT	3	1,5	100-120	200-240	150	290
ERS 4524GT-PWR	6,5	3,3	100-120	200-240	470	478

Wechselstrom-Anschluss

Erforderliches Kabel: Stromkabel (Wechselstrom), das die örtlichen elektrischen Sicherheitsvorschriften erfüllt. Angaben zu den einzelnen Netzsteckern finden Sie in .

Table 3: Internationale Angaben zu Stromkabeln

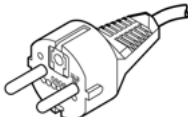
Land/Steckerbeschreibung	Angaben	Typischer Netzstecker
Europa (Kontinent): <ul style="list-style-type: none"> • Stecker CEE7 Standard VII • abgeglichenes Kabel (Markierung HAR auf der Außenseite des Kabels nach 	220 oder 230 V Wechselstrom 50 Hz einphasig	 <small>228FA</small>

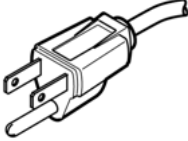
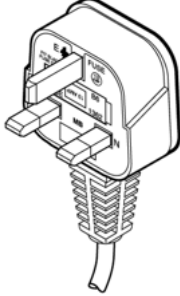
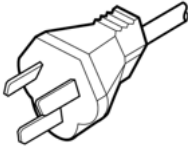
Land/Steckerbeschreibung	Angaben	Typischer Netzstecker
CENELEC Harmonized Document HD-21)		
USA/Kanada/Japan: <ul style="list-style-type: none"> • Stecker NEMA5-15P UL-geprüft • (UL-Stempel auf der Außenseite des Kabels) • CSA-zertifiziert (CSA-Label am Kabel angebracht) 	100 oder 120 V Wechselstrom 50-60 Hz einphasig	 <p style="text-align: center;">227FA</p>
Großbritannien: <ul style="list-style-type: none"> • Stecker BS1363 mit Sicherung • abgeglichenes Kabel 	240 V Wechselstrom 50 Hz einphasig	 <p style="text-align: center;">229FA</p>
Australien: Stecker AS3112-1981	240 V Wechselstrom 50 Hz einphasig	 <p style="text-align: center;">230FA</p>

Der ERS 4500 Series hat keinen Netzschalter. Wenn Sie das Stromkabel an eine geeignete Steckdose anschließen, wird der Switch automatisch eingeschaltet. Die Abbildung zeigen, wie Sie das Stromkabel am ERS 4500 Series anschließen.

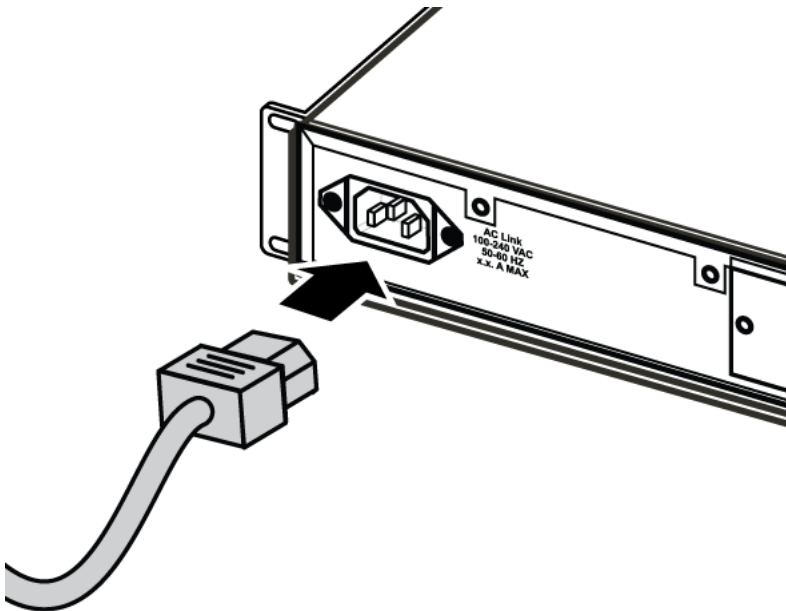

Figure 4: Anschluss des Stromkabels (Wechselstrom) am ERS 4500 Series

Schließen Sie das Stromkabel an der Rückseite des Switch an, und stecken Sie das Kabel dann in eine Steckdose.

Sicherheitsinformationen

⚠ Warning:

Warnung: Die Installation darf nur von qualifiziertem Servicepersonal durchgeführt werden. Lesen und befolgen Sie alle Warnhinweise und Anleitungen, die auf dem Produkt ausgewiesen oder in der Dokumentation enthalten sind.

⚠ Danger:

Gefahr: Diese Ausstattung setzt voraus, dass die jeweilige Einrichtung vor Überstrom geschützt ist. Achten Sie darauf, dass die Spannung der Sicherung oder des Schutzschalters, die für die Phasenleiter verwendet wird, nicht mehr als 240 V Wechselstrom, 16 A beträgt.

⚠ Caution:

Achtung: Dieses Gerät ist ein Produkt der Klasse A. In Wohngebieten kann das Gerät Hochfrequenzstörungen verursachen. In diesem Fall muss der Benutzer geeignete Maßnahmen ergreifen.

 **Caution:**

Achtung: Wenn Sie das Gerät in einem Rack installieren, platzieren Sie Einheiten im Rack nicht direkt übereinander. Jede Einheit im Rack muss mit dafür geeigneten Winkeln befestigt werden. Die Winkel sind nicht dazu geeignet, mehrere Einheiten zu tragen.

 **Danger:**

Gefahr: Verwenden Sie nur geerdete Stromkabel. Ohne Erdung besteht die Gefahr, dass eine Person beim Berühren des Switch einen elektrischen Schlag erhält. Das Fehlen einer Erdung zum Switch kann übermäßige Emissionen zur Folge haben.

 **Warning:**

Warnung: Der Strom für dieses Gerät kann nur durch Herausziehen des Stromkabels abgeschaltet werden. Schließen Sie das Stromkabel stets an einer Steckdose an, die Sie in einem Notfall schnell und sicher erreichen können.

 **Warning:**

Warnung: Glasfaser-Ausrüstung kann Laser oder Infrarotlicht abgeben, die Ihre Augen beschädigen können. Sehen Sie nie direkt in eine Glasfaser oder einen Verbindungsport. Denken Sie stets daran, dass Glasfaserkabel an eine Lichtquelle angeschlossen sein können.



 **Danger:**

Achtung: Gefahr der Explosion, wenn Batterie nach einer falschen Art ersetzt wird. Entledigen Sie sich benutzte Batterien entsprechend den Anweisungen.

Chapter 4: Español

Antes de comenzar

Asegúrese de que el área donde va a instalar y utilizar el ERS 4500 Series cumple los siguientes requisitos medioambientales:

- Temperatura ambiente entre 0° y 50° C (32° y 106° F)
- Humedad relativa entre el 10% y el 90%, sin condensación
- No estar cerca de fuentes de calor como conductos de aire caliente ni de la luz directa del sol
- No estar cerca de fuentes con altos niveles de ruido electromagnético
- No contener niveles de polvo excesivos
- Contar con una fuente de alimentación adecuada a menos de 1.8 metros (6 pies); se requiere un circuito de 15 amperios para cada fuente de alimentación
- Disponer de al menos 5.08 cm (2 pulgadas) a cada lado de la unidad del conmutador para ventilación
- Disponer de espacio suficiente en la parte delantera y posterior del conmutador para poder acceder a los cables

Si desea instalar un ERS 4500 Series en una mesa o estantería, asegúrese de que la superficie puede soportar al menos de 7 a 9 kg (de 15 a 20 libras).

Instalación del conmutador en una mesa o estantería

Puede instalar un ERS 4500 Series en cualquier superficie plana que pueda soportar de forma segura el peso del conmutador y de los cables que lo acompañan (de 7 a 9 kg o de 15 a 20 libras).

La figura se proporcionan instrucciones sobre cómo instalar el conmutador en una mesa o estantería.

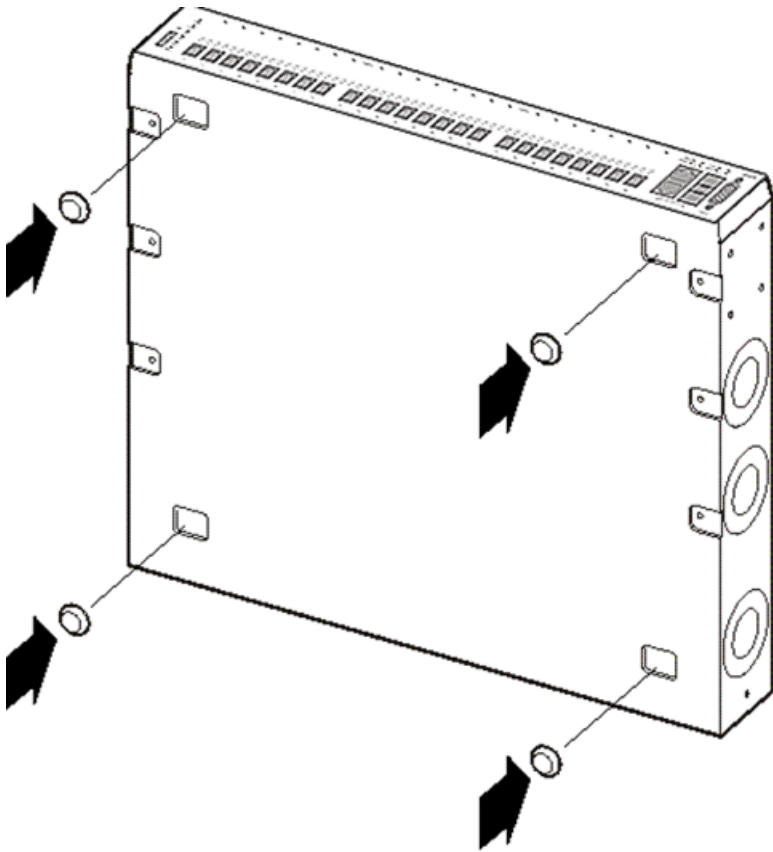

10753FC

Fije las patillas de goma en los lugares marcados.

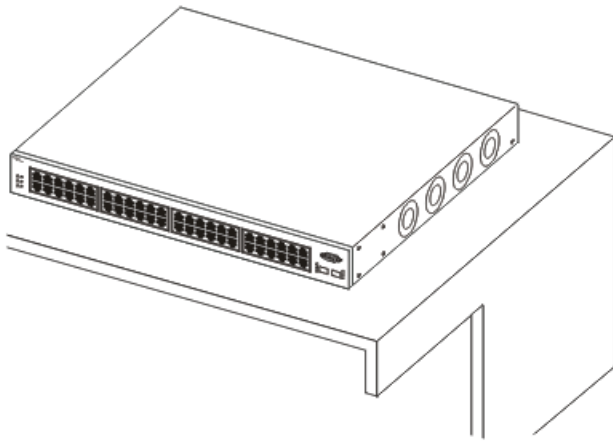

10754FC

Coloque el conmutador en una mesa o estantería.

*** Note:**

Nota: deje al menos 5.1 cm (2 pulg.) a cada lado para que el dispositivo pueda ventilarse de forma correcta y 12.7 cm (5 pulg.) en la parte posterior para el cable de alimentación.

Instalación del conmutador en un bastidor para equipos

Herramienta necesaria: destornillador Phillips para unir los soportes al conmutador

Requisitos del bastidor:

- Se necesita un espacio de 6 cm (2.8 pulg.) para cada conmutador en un bastidor para equipos de 48.2 cm (19 pulg.) que cumpla con la norma EIA o IEC.
- El bastidor debe estar atornillado al suelo y anclado, si es necesario.
- El bastidor debe estar conectado a tierra con el mismo electrodo de conexión a tierra utilizado por el servicio eléctrico de la zona. La conexión a tierra debe ser permanente y no deberá superar 1 ohmio de resistencia desde el bastidor hasta el electrodo de conexión a tierra.

En la Figura se proporcionan instrucciones sobre cómo instalar el conmutador en un bastidor.

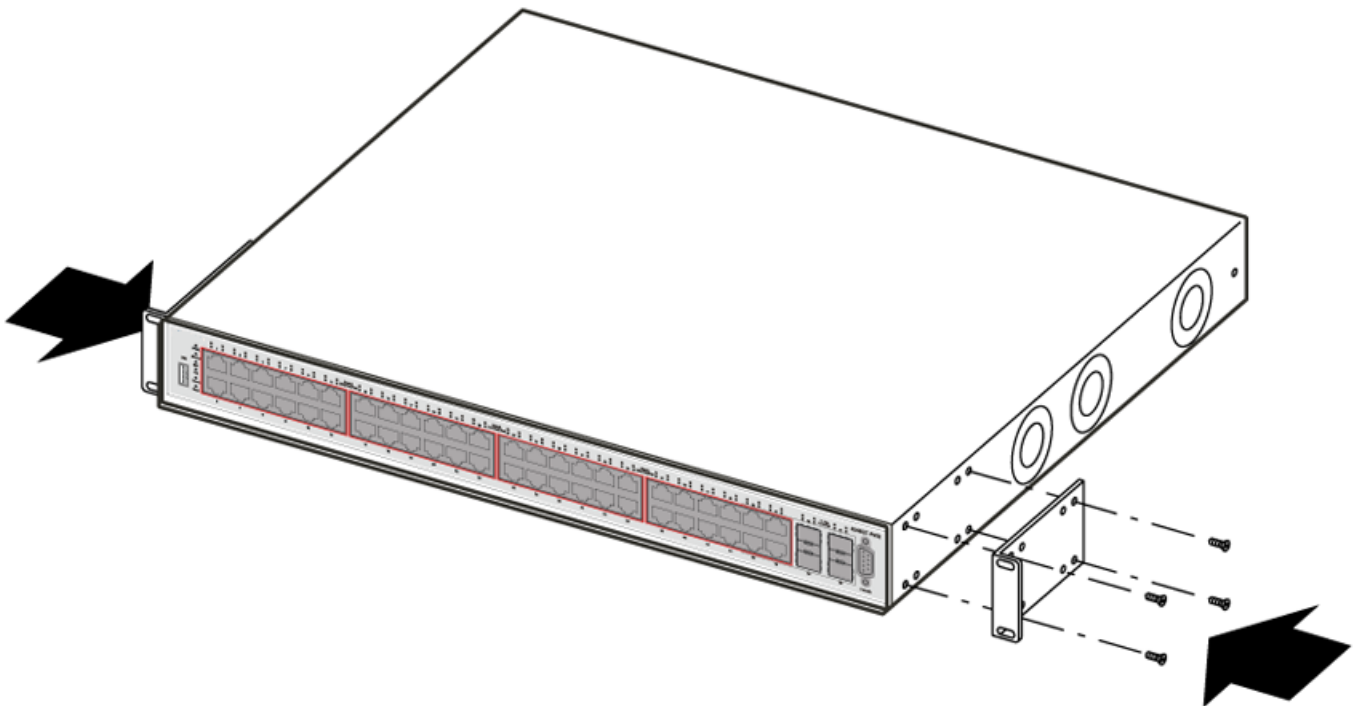

Coloque un soporte a cada lado del conmutador.

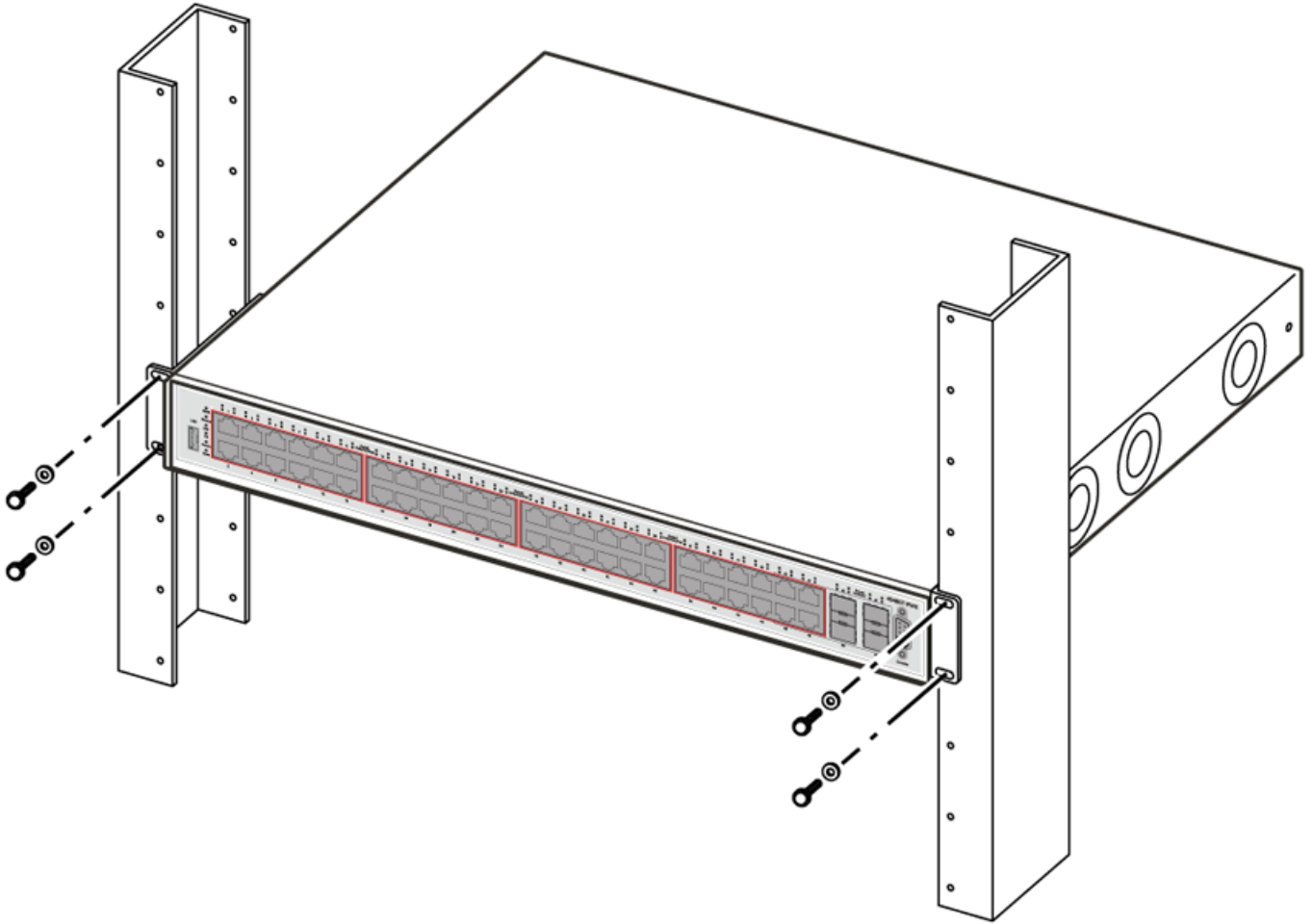

Introduzca el conmutador en el bastidor. Introduzca y apriete los tornillos para el montaje en bastidor.

Especificaciones eléctricas

Especificaciones eléctricas de CA

La tabla siguiente describe las especificaciones eléctricas de CA para el ERS 4500 Series sin fuente de alimentación.

Modelo	Corriente de entrada: (Maximo A 100-120 VAC)	Corriente de entrada: (Maximo A) 200-240 VAC	Voltaje de entrada (rms):	Voltaje de entrada (rms):	Consumo de energía: (Maximo W)	Nivel térmico: (Btu/h maximo)
ERS 4548GT	3	1.5	100-120	200-240	150	415
ERS 4548GT-PWR	6.5	3.3	100-120	200-240	470	788
ERS 4550T	3	1.5	100-120	200-240	150	240
ERS 4550T-PWR	6.5	3.3	100-120	200-240	470	615
ERS 4526FX	3	1.5	100-120	200-240	150	256
ERS 4526GTX-PWR	6.5	3.3	100-120	200-240	470	546
ERS 4526GTX	3	1.5	100-120	200-240	150	307
ERS 4526T-PWR	6.5	3.3	100-120	200-240	470	375
ERS 4526T	3	1.5	100-120	200-240	150	188
ERS 4524GT	3	1.5	100-120	200-240	150	290
ERS 4524GT-PWR	6.5	3.3	100-120	200-240	470	478

Conexión a CA

Cable necesario: cable de alimentación de CA que cumpla los requisitos del código eléctrico local. Consulte la tabla para obtener información sobre los enchufes.

Table 4: Especificaciones internacionales sobre clases de alimentación

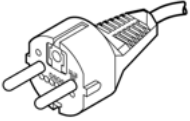
País/descripción del enchufe	Especificaciones	Enchufe típico
Europa continental: • Enchufe macho CEE7 estándar VII • Cable armonizado (marca HAR en el exterior de la funda para cumplir con el documento de armonización HD-21 de CENELEC)	220 o 230 V CA 50 Hz Monofásico	 228FA

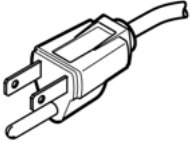
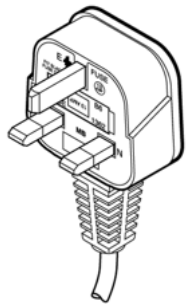
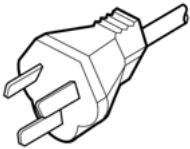
País/descripción del enchufe	Especificaciones	Enchufe típico
EE.UU./Canadá/Japón: <ul style="list-style-type: none"> • Enchufe macho NEMA5-15P • Reconocido por UL (UL impreso en la funda del cable) • Certificado por CSA (etiqueta de CSA en el cable) 	100 o 120 V CA 50-60 Hz Monofásico	 227FA
Reino Unido: <ul style="list-style-type: none"> • Enchufe macho BS1363 con fusible • Cable armonizado 	240 V CA 50 Hz Monofásico	 229FA
Australia: Enchufe macho AS3112-1981	240 V CA 50 Hz Monofásico	 230FA

El ERS 4500 Series no dispone de un interrupto de alimentación. Al conectar el cable de alimentación d CA a un conector de entrada CA adecuada, el conmutador se activa inmediatamente. La figura se muestra cómo conectar el cable de alimentación al ERS 4500 Series.

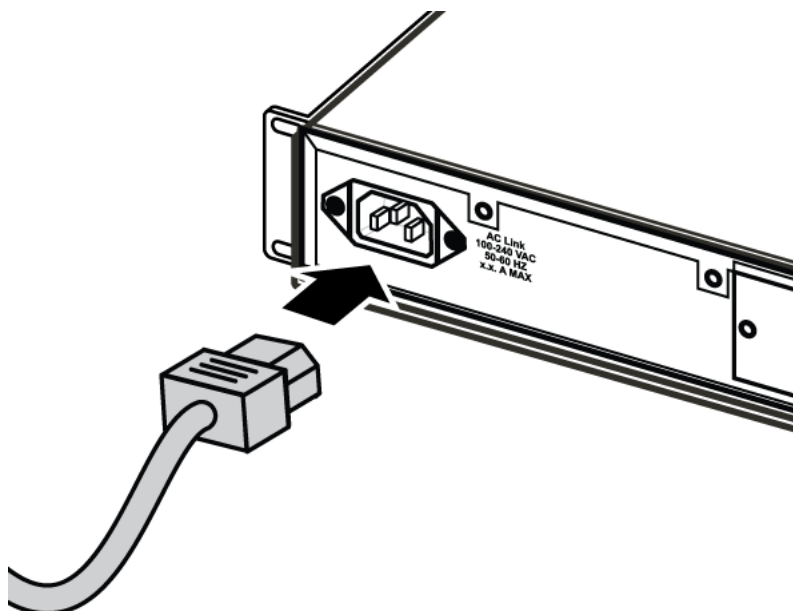

Mensajes de seguridad

⚠ Warning:

Aviso: sólo el personal de servicio cualificado puede realizar la instalación. Lea y siga todos los avisos e instrucciones de advertencia grabados en el producto o incluidos en la documentación.

⚠ Danger:

Peligro: este equipo confía en la instalación del edificio para la protección contra sobrecargas. Asegúrese de que en los conductores de fase se utiliza un fusible o un disyuntor de menos de 240 V CA, 16 A internacional (120 V CA, 15 A en EE.UU.).

⚠ Caution:

Precaución: este dispositivo es un producto de Clase A. En un entorno doméstico, este dispositivo puede causar radiointerferencias, en cuyo caso se le puede solicitar al usuario que tome las medidas apropiadas.

⚠ Caution:

Precaución: al montar este dispositivo en un bastidor, no apile las unidades directamente una encima de otra. Cada unidad debe estar fijada al bastidor con los soportes de montaje apropiados. Los soportes de montaje no están diseñados para soportar varias unidades.

 **Danger:**

Peligro: utilice sólo cables de alimentación que tengan conexión a tierra. Sin una toma de tierra adecuada, cualquier persona que toque el conmutador estará en peligro de recibir una descarga eléctrica. La no existencia de una conexión a tierra puede dar lugar a emisiones excesivas.

 **Warning:**

Aviso: el único modo de apagar este dispositivo es desconectando el cable de alimentación. Conecte siempre el cable de alimentación en un lugar que sea de acceso rápido y seguro en caso de emergencia.

 **Warning:**

Aviso: el equipamiento de fibra óptica puede emitir luz láser o infrarroja que puede dañar los ojos. No mire nunca a través de un puerto de fibra óptica ni de un puerto conector. Tenga en cuenta siempre que los cables de fibra óptica están conectados a una fuente de luz.



 **Caution:**

Precaución: Riesgo de la explosión si la batería es substituida por un tipo incorrecto. Disponga de las baterías usadas según las instrucciones.

Chapter 5: Français

Avant de commencer

Assurez-vous que l'endroit où vous installez le commutateur ERS 4500 Series et où vous l'utiliserez soit conforme aux conditions environnementales suivantes:

- Température ambiante entre 0° et 50° C (32° et 106° F)
- Humidité relative entre 10 % et 90 % sans condensation
- Aucune source de chaleur à proximité, comme par exemple une ventilation chaude ou la lumière directe du soleil
- Aucune source de bruit électromagnétique à proximité
- Pas de poussière excessive
- Source d'alimentation à une distance maximale de 180 cm. Circuit 15 Amp nécessaire pour chaque alimentation
- Distance minimale de 5,08 cm (2 po) de chaque côté de l'unité de commutation pour la ventilation
- Espace approprié à l'avant et à l'arrière du commutateur pour faciliter l'accès aux câbles.

Si vous installez un seul commutateur ERS 4500 Series sur une table ou sur une étagère, assurez-vous que cette surface puisse supporter un poids d'au moins 7 à 9 kg (15 à 20 livres).

Installation du commutateur sur une table ou sur une étagère

Vous pouvez installer un commutateur ERS 4500 Series sur toute surface plane pouvant supporter le poids du commutateur et des câbles reliés 7 à 9 kg (15 à 20 livres). La figure fournit des instructions sur l'installation du commutateur sur une table ou sur une étagère.

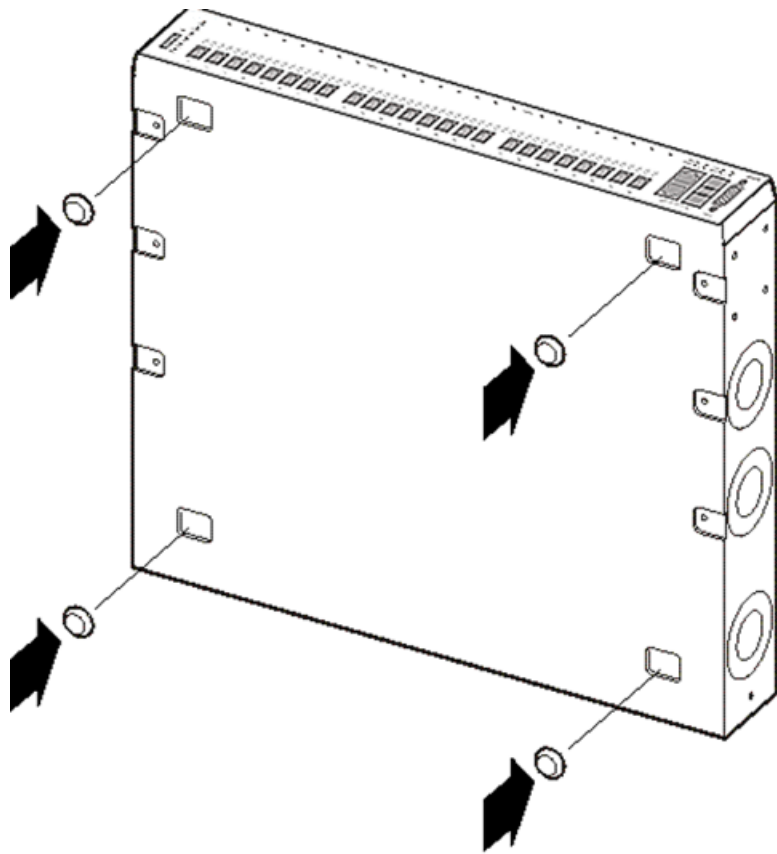

10753FC

Figure 5: Installation du commutateur sur une table ou sur une étagère

Fixez les pieds en caoutchouc aux emplacements indiqués.

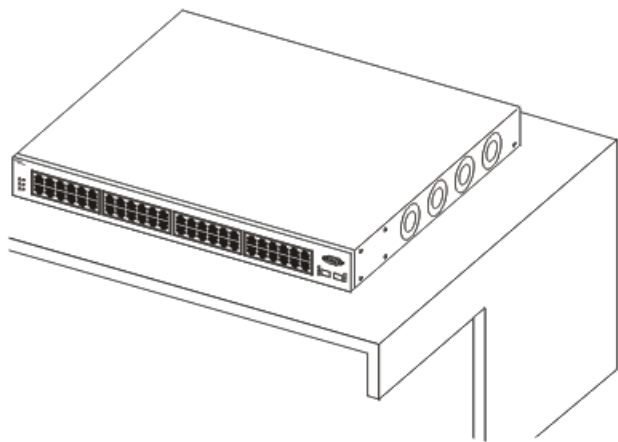

10754FC

Installation du commutateur sur une table.

*** Note:**

Remarque: Laissez au moins 5,1 cm (2 po) de chaque côté pour la ventilation et 12,7 cm (5 po) à l'arrière pour le dégagement du cordon d'alimentation.

Installation du commutateur dans un rack

Outil nécessaire: Un tournevis Philips pour attacher les supports au commutateur.

Configuration pour un rack:

- Un espace de 8,5 cm (2,8 po) est nécessaire pour chaque commutateur dans un rack EIA ou IEC standard de 48 cm (19 po).
- Le rack doit être boulonné au sol et calé si nécessaire.
- Le rack doit être mis à la terre au même conducteur de terre que celui utilisé par le service d'alimentation de l'endroit. Le conducteur de terre doit être permanent et ne doit pas dépasser 1 Ohm de résistance du rack au conducteur de terre.

La figure fournit des instructions sur l'installation du commutateur dans un rack.

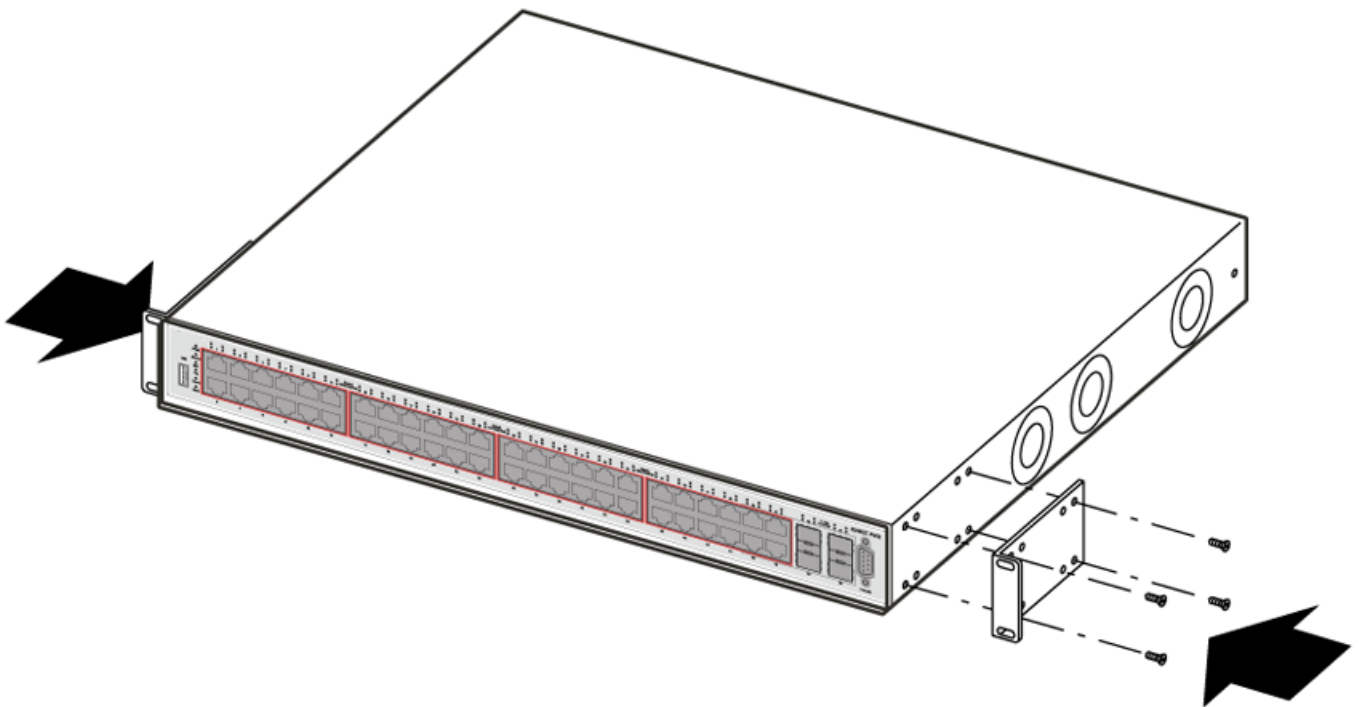
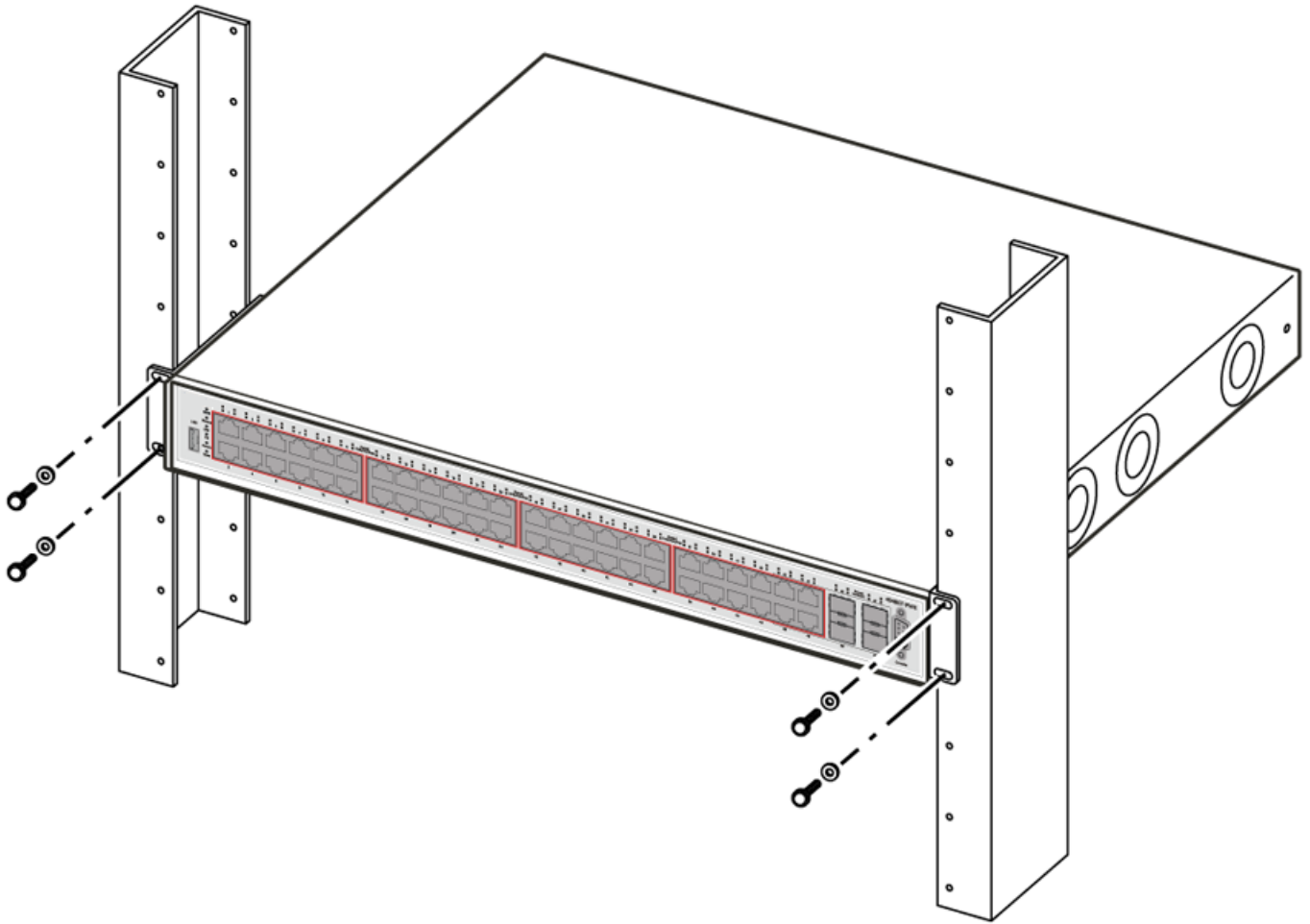

Figure 6: Installation du commutateur dans un rack

Fixez un support de chaque côté du commutateur.



Glissez le commutateur dans le rack. Insérez les vis de montage en rack et serrez-les.

Alimentation: Caractéristiques

Alimentation secteur: caractéristiques

La table suivante décrit les caractéristiques d'alimentation secteur du ERS 4500 Series.

Table 5: Alimentation secteur du ERS 4500: caractéristiques

Modèle	Courant d'entrée A maximum		Voltage d'entrée		Consom- mation d'énergie	Puissance thermique maximum
	100-120 VAC	200-240 VAC	rms		W maximum	Btu/h
ERS 4548GT	3	1,5	100-120 Vca a 50-60 Hz	200-240 Vca a 50-60 Hz	150	415
ERS 4548GT- PWR	6,5	3,3	100-120 Vca a 50-60 Hz	200-240 Vca a 50-60 Hz	470	788
ERS 4550T	3	1,5	100-120 Vca a 50-60 Hz	200-240 Vca a 50-60 Hz	150	240
ERS 4550T- PWR	6,5	3,3	100-120 Vca a 50-60 Hz	200-240 Vca a 50-60 Hz	470	615
ERS 4526FX	3	1,5	100-120 Vca a 50-60 Hz	200-240 Vca a 50-60 Hz	150	256
ERS 4526GTX- PWR	6,5	3,3	100-120 Vca a 50-60 Hz	200-240 Vca a 50-60 Hz	470	546
ERS 4526GTX	3	1,5	100-120 Vca a 50-60 Hz	200-240 Vca a 50-60 Hz	150	307
ERS 4526T- PWR	6,5	3,3	100-120 Vca a 50-60 Hz	200-240 Vca a 50-60 Hz	470	375
ERS 4526T	3	1,5	100-120 Vca a 50-60 Hz	200-240 Vca a 50-60 Hz	150	188
ERS 4524GT	3	1,5	100-120 Vca a 50-60 Hz	200-240 Vca a 50-60 Hz	150	290
ERS 4524GT- PWR	6,5	3,3	100-120 Vca a 50-60 Hz	200-240 Vca a 50-60 Hz	470	478

Alimentation secteur: connexion

Câble requis: Un cordon d'alimentation conforme aux conditions de votre code électrique local. Reportez-vous au tableau pour les caractéristiques des prises.

Table 6: Cordons secteurs internationaux: caractéristiques

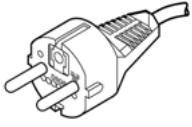
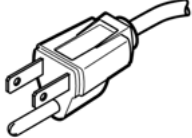
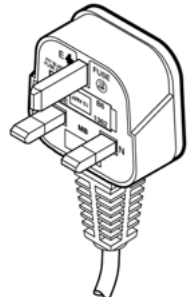
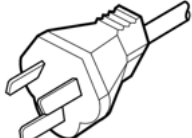
Pays/Description de la prise	Caractéristiques	Prise habituelle
Europe continentale: <ul style="list-style-type: none"> • Prise mâle CEE7 standard VII • Cordon harmonisé (une marque HAR sur l'extérieur du cordon montre la conformité au document harmonisé CENELEC HD-21) 	220 ou 230 Vca 50Hz Monophasé	 <p style="text-align: right;">228FA</p>
États-Unis/Canada/Japon: <ul style="list-style-type: none"> • Prise mâle NEMA5-15P • Reconnu par UL (Cachet UL sur le cordon) • Certifié CSA (étiquette CSA fixée sur le cordon) 	100 ou 120 Vca 50-60 Hz Monophasé	 <p style="text-align: right;">227FA</p>
Royaume-Uni: <ul style="list-style-type: none"> • Prise mâle BS1363 avec fusible • Cordon harmonisé 	240 Vca 50 Hz Monophasé	 <p style="text-align: right;">229FA</p>
Australie: Prise mâle AS3112-1981	240 Vca 50 Hz Monophasé	 <p style="text-align: right;">230FA</p>

ERS 4500 Series ne possède pas de commutateur d'alimentation. Lorsque vous connectez le cordon d'alimentation à une sortie d'alimentation secteur appropriée, le commutateur s'allume

immédiatement. La figure décrit la manière de connecter le câble d'alimentation au ERS 4500 Series.

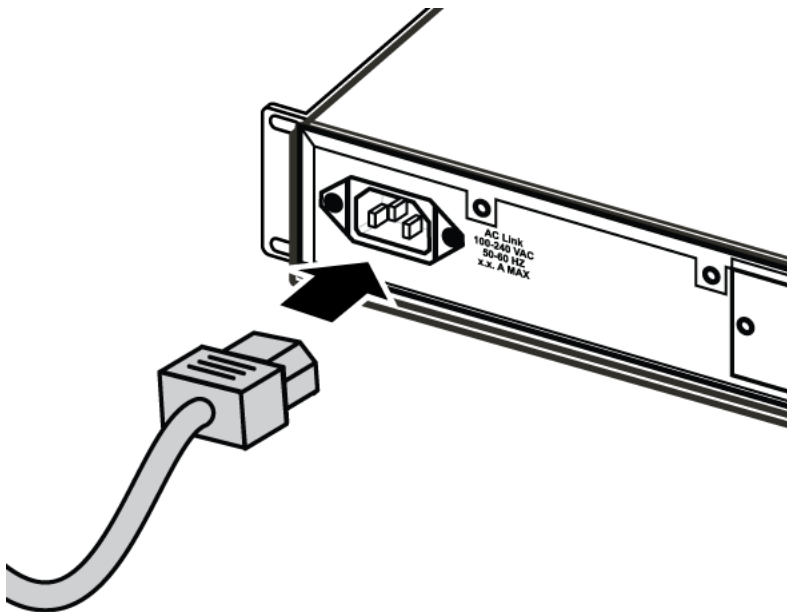

Figure 7: Connexion du cordon secteur au ERS 4500 Series

Connectez le cordon d'alimentation à l'arrière du commutateur, puis à une source d'alime

Messages de sécurité

Warning:

Avertissement: L'installation ne doit être effectuée que par des personnes qualifiées. Lisez toutes les notices et instructions d'avertissement indiquées sur le produit ou dans la documentation et suivez-les.

Danger:

Cet équipement dépend des installations du bâtiment pour la protection de surintensité. Assurez-vous de ne pas utiliser un fusible ou un disjoncteur de plus de 120 Vca, 15 A U.S. (240 Vca, 16 A internationaux) sur les conducteurs de phase.

Caution:

Avertissement: Le périphérique est un produit de Classe A. Dans un environnement domestique, ce périphérique est susceptible de provoquer des interférences radio, auquel cas l'utilisateur doit prendre les mesures appropriées.

 **Caution:**

Avertissement: Si vous montez cet appareil en rack, ne superposez pas les unités directement les unes sur les autres dans le rack. Chaque unité doit être fixée au rack à l'aide des supports de montage appropriés. Les supports de montage ne sont pas conçus pour supporter plusieurs unités.

 **Voltage:**

Utilisez uniquement des cordons d'alimentation possédant un conducteur de terre. S'il n'y a pas de conducteur de terre, une personne qui touche le commutateur peut recevoir un choc électrique. L'absence de conducteur de terre au commutateur peut provoquer des émissions excessives.

 **Warning:**

Avertissement: La seule manière de couper l'alimentation de l'appareil est de déconnecter le cordon d'alimentation. Connectez toujours le cordon d'alimentation à un endroit accessible rapidement et en toute sécurité en cas d'urgence.

 **Warning:**

Avertissement: L'équipement de fibres optiques peut émettre une lumière laser ou infrarouge nuisible à vos yeux. Ne regardez jamais en direction de fibres optiques ou d'un port connecteur. Supposez toujours que les câbles de fibres optiques sont connectés à une source de lumière.



 **Caution:**

Avertissement: Risque d'explosion si la batterie est remplacée par un type incorrect. Débarassez-vous des batteries utilisées selon les instructions.

Chapter 6: Português

Antes de começar

Verifique se a área onde deseja instalar e usar o Ethernet Routing Switch 4500 atende aos seguintes requisitos ambientais:

- Temperatura ambiente entre 0° e 50° C (32° e 106° F)
- Umidade relativa entre 10% e 90% sem condensação
- Nenhuma proximidade a fontes de calor como aberturas de ar quente ou luz solar direta
- Nenhuma proximidade a fontes de intenso ruído eletromagnético
- Não haja poeira excessiva
- Fonte de alimentação adequada acerca de 1,83 m; é necessário um circuito de 15 A para cada fonte de alimentação
- Pelo menos 2 polegadas (5,08 cm) de cada lado da unidade comutadora para ventilação
- Espaço adequado na parte frontal e posterior do comutador para acesso aos cabos

Instalação do comutador em uma mesa ou estante

É possível instalar um único Ethernet Routing Switch 4500 em qualquer superfície plana que possa suportar com segurança o peso do comutador e dos cabos conectados (7 a 9 kg). A figura fornece instruções sobre a instalação do comutador em uma mesa ou estante.

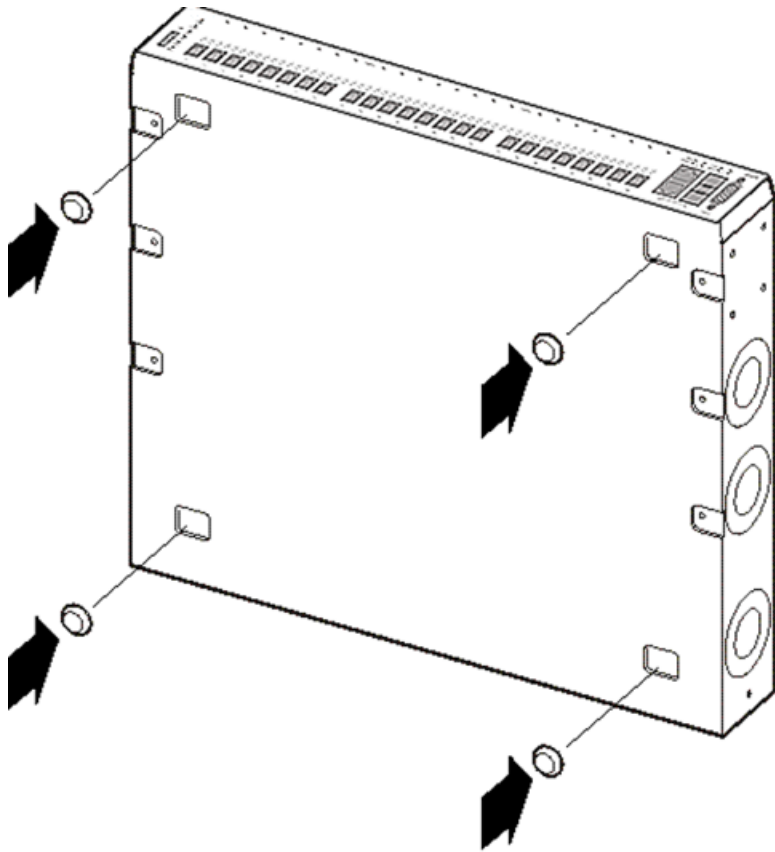

10753FC

Figure 8: Instalação do comutador em uma mesa ou estante

Instale os pés emborrachados nos locais marcados.

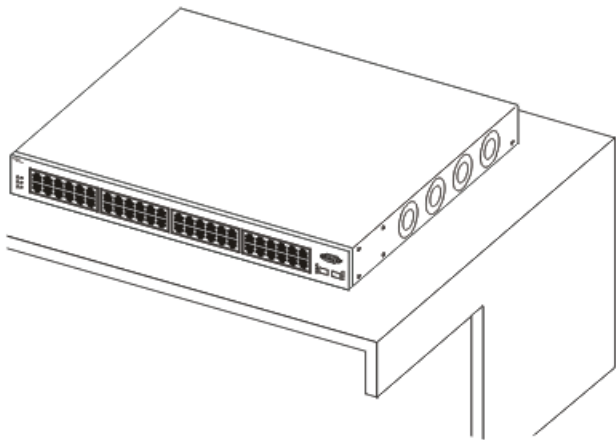

10754FC

Ajuste o comutador em uma mesa ou estante.

*** Note:**

Observação: Deixe pelo menos 2 polegadas (5,1 cm) de cada lado para ventilação adequada e pelo menos 5 polegadas (12,7 cm) na parte posterior para liberação do cabo de alimentação.

Instalação do comutador em um rack de equipamento

Ferramenta necessária: Chave de fenda Phillips para conexão dos suportes ao comutador

Requisitos do rack:

- É necessário um espaço de 2,8 polegadas de cada lado do comutador em um rack de equipamento padrão EIA ou IEC de 19 polegadas (48,2 cm).
- Se necessário, o rack deve ser preso ao chão e fixado.
- O rack deve ser aterrado ao mesmo eletrodo de aterramento usado pela companhia elétrica da região. O caminho de aterramento deve ser permanente e não exceder 1 ohm de resistência do rack ao eletrodo de aterramento.

A figura fornece instruções sobre a instalação do comutador em um rack.

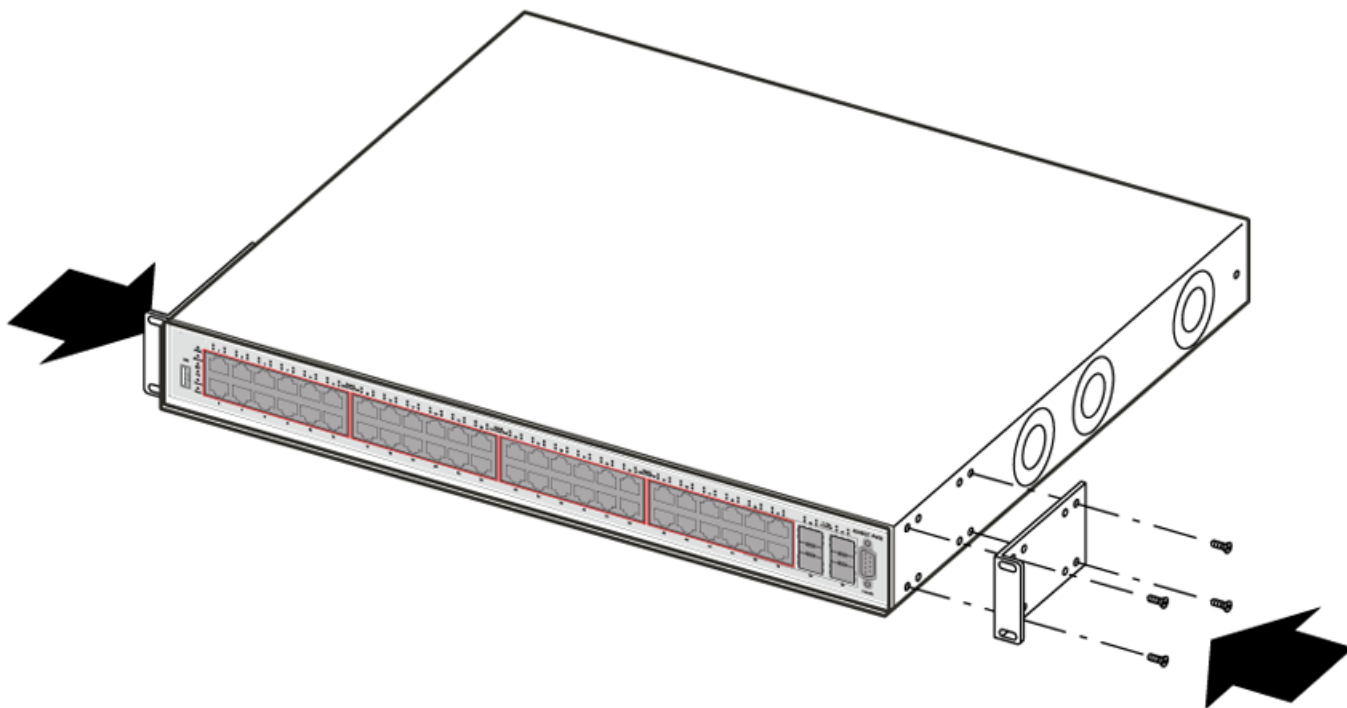
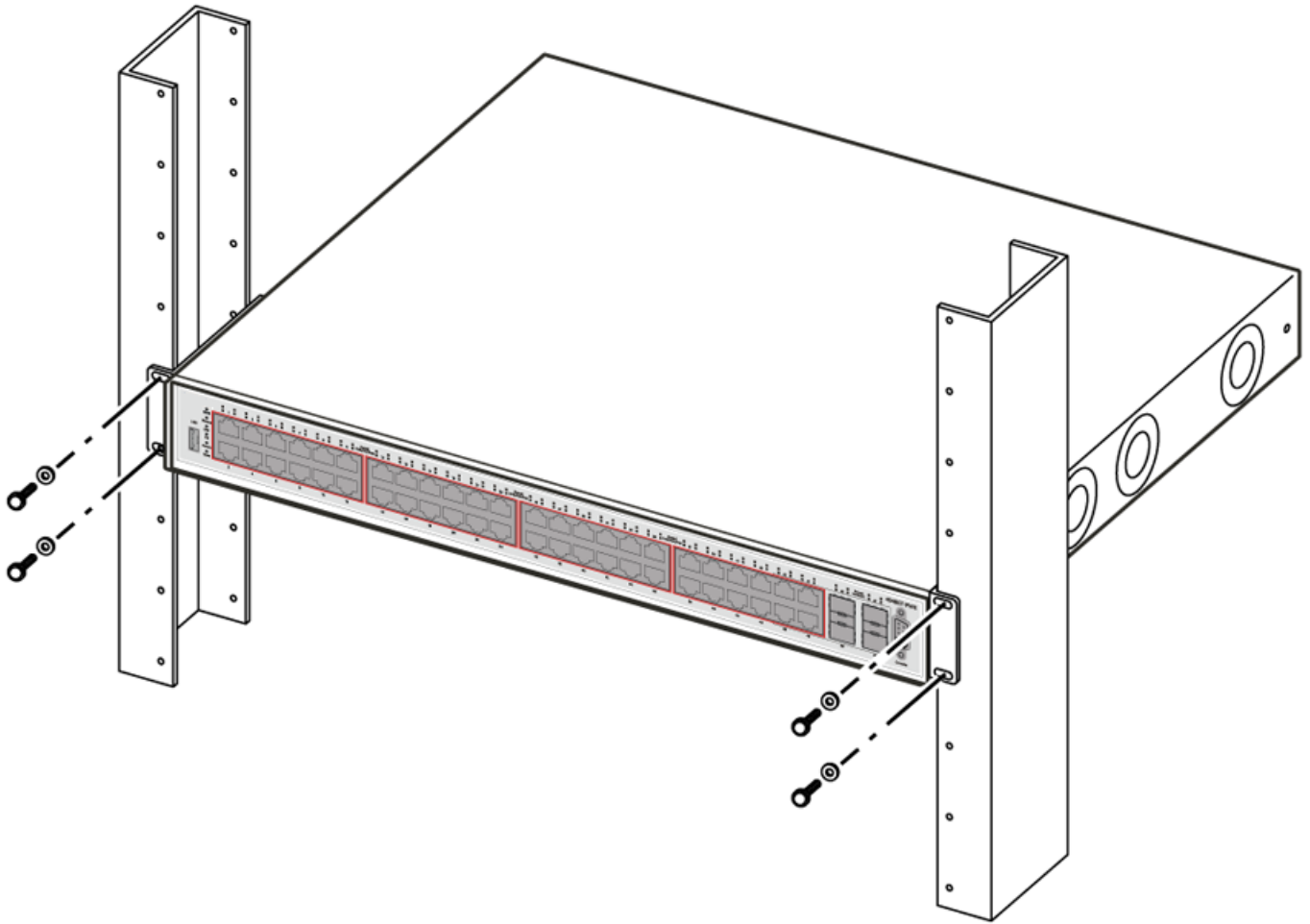

Figure 9: Instalação do comutador em um rack

Conecte um suporte em cada lado do comutador.



Deslize o comutador no rack. Insira e aperte os parafusos de montagem em rack.

Especificações do energia

Especificações de alimentação CA

A seguinte tabela descreve as especificações de alimentação CA para o Ethernet Routing Switch 4500 Series.

Table 7: Especificações de alimentação CA: Ethernet Routing Switch 4500 Series

Modelo	Corrente de entrada: (Máximo A, 100-120 VCA)	Corrente de entrada: (Máximo A, 200-240 VCA)	Tensão de entrada (rms):	Tensão de entrada (rms):	Consumo de energia: (Máximo W)	Potência térmica: (Btu/h Máximo)
ERS 4548GT	3	1,5	100-120 VCA a 50-60 Hz	200-240 VCA a 50-60 Hz	150	415
ERS 4548GT-PWR	6,5	3,3	100-120 VCA a 50-60 Hz	200-240 VCA a 50-60 Hz	470	788
ERS 4550T	3	1,5	100-120 VCA a 50-60 Hz	200-240 VCA a 50-60 Hz	150	240
ERS 4550T-PWR	6,5	3,3	100-120 VCA a 50-60 Hz	200-240 VCA a 50-60 Hz	470	615
ERS 4526FX	3	1,5	100-120 VCA a 50-60 Hz	200-240 VCA a 50-60 Hz	150	256
ERS 4526GTX-PWR	6,5	3,3	100-120 VCA a 50-60 Hz	200-240 VCA a 50-60 Hz	470	546
ERS 4526GTX	3	1,5	100-120 VCA a 50-60 Hz	200-240 VCA a 50-60 Hz	150	307
ERS 4526T-PWR	6,5	3,3	100-120 VCA a 50-60 Hz	200-240 VCA a 50-60 Hz	470	375
ERS 4526T	3	1,5	100-120 VCA a 50-60 Hz	200-240 VCA a 50-60 Hz	150	188
ERS 4524GT	3	1,5	100-120 VCA a 50-60 Hz	200-240 VCA a 50-60 Hz	150	290
ERS 4524GT-PWR	6,5	3,3	100-120 VCA a 50-60 Hz	200-240 VCA a 50-60 Hz	470	478

Conexão da alimentação CA

Cabo requerido: Cabo de alimentação CA que atende os requisitos de seu código de eletricidade local. Consulte a tabela para obter especificações de conector.

Table 8: Especificações internacionais de cabo de alimentação

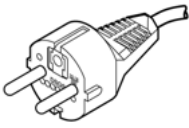
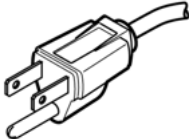
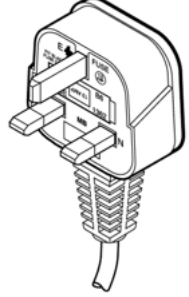
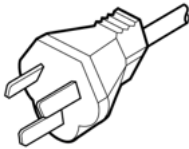
Pais/descrição de conector	Especificações	Conector típico
Europa: <ul style="list-style-type: none"> • Conector macho VII padrão CEE7 • Cabo harmonizado (marca HAR no lado externo da tomada do cabo em conformidade com o documento CENELEC Harmonized Document HD-21) 	220 ou 230 VCA 50Hz Uma fase	 228FA
EUA/Canadá/Japão: <ul style="list-style-type: none"> • Conector macho NEMA5-15P • Reconhecido por UL (UL estampado na tomada do cabo) • Certificado por CSA (etiqueta de CSA presa no cabo) 	100 ou 120 VCA 50-60 Hz Uma fase	 227FA
Reino Unido: <ul style="list-style-type: none"> • Conector macho BS1363 com fusível • Cabo harmonizado 	240 VCA 50 Hz Uma fase	 229FA
Austrália: Conector macho AS3112-1981	240 VCA 50 Hz Uma fase	 230FA

O Ethernet Routing Switch 4500 Series não possui um interruptor de alimentação. Ao conectar o cabo de alimentação CA a uma tomada de alimentação CA adequada, o comutador é

alimentado imediatamente. Da figura mostram como conectar o cabo de alimentação CA ao Ethernet Routing Switch 4500 Series.

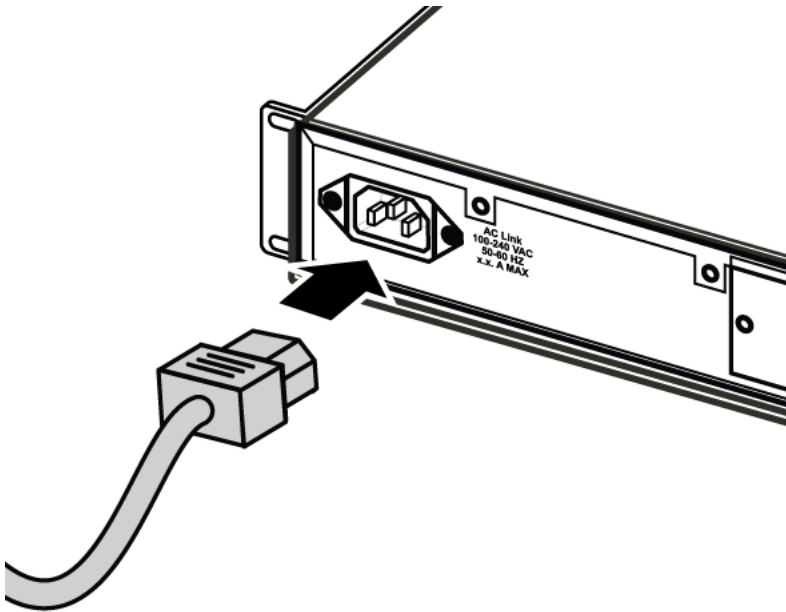

Figure 10: Conexão do cabo de alimentação CA ao Ethernet Routing Switch 4500 Series

Conecte o cabo de alimentação CA à parte posterior do Ethernet Routing Switch 4500 Series e, em seguida, conecte o cabo a uma tomada de alimentação.

Mensagens de segurança

⚠ Warning:

Aviso: A instalação só deve ser executada por técnicos qualificados. Leia e siga todos os avisos e instruções marcados no produto ou fornecidos na documentação.

⚠ Danger:

Perigo: Este equipamento depende da instalação do edifício para proteção contra corrente excessiva. Certifique-se de que um fusível ou disjuntor não superior a 120 VCA, 15 A EUA (240 VCA, 16 A Internacional) é utilizado nos condutores de fase.

⚠ Caution:

Atenção: Este dispositivo é um produto Classe A. Em um ambiente doméstico, este dispositivo pode causar interferência de rádio. Nesses casos, o usuário deverá tomar as medidas adequadas.

 **Caution:**

Atenção: Ao montar este dispositivo em um rack, não empilhe as unidades diretamente uma sobre a outra no rack. Cada unidade deve ser presa ao rack com os suportes de montagem apropriados. Os suportes de montagem não são projetados para suportar várias unidades.

 **Voltage:**

Perigo: Use apenas cabos de alimentação que possuam um caminho de aterramento. Sem um aterramento adequado, se uma pessoa tocar no computador corre o risco receber um choque elétrico. A falta de um caminho de aterramento para o computador pode resultar em emissões excessivas.

 **Warning:**

Aviso: Desconectar o cabo de alimentação é o único modo de desligar a energia deste dispositivo. Sempre conecte o cabo de alimentação em um local em que possa ser alcançado de forma rápida e segura em caso de emergência.

 **Warning:**

Aviso: Equipamento de fibra óptica pode emitir luz laser ou infravermelha que pode ferir os olhos. Nunca olhe em uma fibra óptica ou porta conectora. Sempre considere que os cabos de fibra óptica são conectados a uma fonte de iluminação.



 **Caution:**

Atenção: Risco da explosão se a bateria for substituída por um tipo incorreto. Disponha de baterias usadas de acordo com as instruções.

