



# **Installing Avaya Ethernet Routing Switch 5900 Series**

Release 7.2  
NN47211-300  
Issue 03.02  
August 2016

## Notice

While reasonable efforts have been made to ensure that the information in this document is complete and accurate at the time of printing, Avaya assumes no liability for any errors. Avaya reserves the right to make changes and corrections to the information in this document without the obligation to notify any person or organization of such changes.

## Documentation disclaimer

"Documentation" means information published in varying mediums which may include product information, operating instructions and performance specifications that are generally made available to users of products. Documentation does not include marketing materials. Avaya shall not be responsible for any modifications, additions, or deletions to the original published version of Documentation unless such modifications, additions, or deletions were performed by or on the express behalf of Avaya. End User agrees to indemnify and hold harmless Avaya, Avaya's agents, servants and employees against all claims, lawsuits, demands and judgments arising out of, or in connection with, subsequent modifications, additions or deletions to this documentation, to the extent made by End User.

## Link disclaimer

Avaya is not responsible for the contents or reliability of any linked websites referenced within this site or Documentation provided by Avaya. Avaya is not responsible for the accuracy of any information, statement or content provided on these sites and does not necessarily endorse the products, services, or information described or offered within them. Avaya does not guarantee that these links will work all the time and has no control over the availability of the linked pages.

## Warranty

Avaya provides a limited warranty on Avaya hardware and software. Refer to your sales agreement to establish the terms of the limited warranty. In addition, Avaya's standard warranty language, as well as information regarding support for this product while under warranty is available to Avaya customers and other parties through the Avaya Support website: <https://support.avaya.com/helpcenter/getGenericDetails?detailId=C20091120112456651010> under the link "Warranty & Product Lifecycle" or such successor site as designated by Avaya. Please note that if You acquired the product(s) from an authorized Avaya Channel Partner outside of the United States and Canada, the warranty is provided to You by said Avaya Channel Partner and not by Avaya.

"Hosted Service" means an Avaya hosted service subscription that You acquire from either Avaya or an authorized Avaya Channel Partner (as applicable) and which is described further in Hosted SAS or other service description documentation regarding the applicable hosted service. If You purchase a Hosted Service subscription, the foregoing limited warranty may not apply but You may be entitled to support services in connection with the Hosted Service as described further in your service description documents for the applicable Hosted Service. Contact Avaya or Avaya Channel Partner (as applicable) for more information.

## Hosted Service

THE FOLLOWING APPLIES ONLY IF YOU PURCHASE AN AVAYA HOSTED SERVICE SUBSCRIPTION FROM AVAYA OR AN AVAYA CHANNEL PARTNER (AS APPLICABLE), THE TERMS OF USE FOR HOSTED SERVICES ARE AVAILABLE ON THE AVAYA WEBSITE, [HTTPS://SUPPORT.AVAYA.COM/LICENSEINFO](https://support.avaya.com/LICENSEINFO) UNDER THE LINK "Avaya Terms of Use for Hosted Services" OR SUCH SUCCESSOR SITE AS DESIGNATED BY AVAYA, AND ARE APPLICABLE TO ANYONE WHO ACCESSES OR USES THE HOSTED SERVICE. BY ACCESSING OR USING THE HOSTED SERVICE, OR AUTHORIZING OTHERS TO DO SO, YOU, ON BEHALF OF YOURSELF AND THE ENTITY FOR WHOM YOU ARE DOING SO (HEREINAFTER REFERRED TO INTERCHANGEABLY AS "YOU" AND "END USER"), AGREE TO THE TERMS OF USE. IF YOU ARE ACCEPTING THE TERMS OF USE ON BEHALF A COMPANY OR OTHER LEGAL ENTITY, YOU REPRESENT THAT YOU HAVE THE AUTHORITY TO BIND SUCH ENTITY TO THESE TERMS OF USE. IF YOU DO NOT HAVE SUCH AUTHORITY, OR

IF YOU DO NOT WISH TO ACCEPT THESE TERMS OF USE, YOU MUST NOT ACCESS OR USE THE HOSTED SERVICE OR AUTHORIZE ANYONE TO ACCESS OR USE THE HOSTED SERVICE.

## Licenses

THE SOFTWARE LICENSE TERMS AVAILABLE ON THE AVAYA WEBSITE, [HTTPS://SUPPORT.AVAYA.COM/LICENSEINFO](https://support.avaya.com/LICENSEINFO), UNDER THE LINK "AVAYA SOFTWARE LICENSE TERMS (Avaya Products)" OR SUCH SUCCESSOR SITE AS DESIGNATED BY AVAYA, ARE APPLICABLE TO ANYONE WHO DOWNLOADS, USES AND/OR INSTALLS AVAYA SOFTWARE, PURCHASED FROM AVAYA INC., ANY AVAYA AFFILIATE, OR AN AVAYA CHANNEL PARTNER (AS APPLICABLE) UNDER A COMMERCIAL AGREEMENT WITH AVAYA OR AN AVAYA CHANNEL PARTNER. UNLESS OTHERWISE AGREED TO BY AVAYA IN WRITING, AVAYA DOES NOT EXTEND THIS LICENSE IF THE SOFTWARE WAS OBTAINED FROM ANYONE OTHER THAN AVAYA, AN AVAYA AFFILIATE OR AN AVAYA CHANNEL PARTNER; AVAYA RESERVES THE RIGHT TO TAKE LEGAL ACTION AGAINST YOU AND ANYONE ELSE USING OR SELLING THE SOFTWARE WITHOUT A LICENSE. BY INSTALLING, DOWNLOADING OR USING THE SOFTWARE, OR AUTHORIZING OTHERS TO DO SO, YOU, ON BEHALF OF YOURSELF AND THE ENTITY FOR WHOM YOU ARE INSTALLING, DOWNLOADING OR USING THE SOFTWARE (HEREINAFTER REFERRED TO INTERCHANGEABLY AS "YOU" AND "END USER"), AGREE TO THESE TERMS AND CONDITIONS AND CREATE A BINDING CONTRACT BETWEEN YOU AND AVAYA INC. OR THE APPLICABLE AVAYA AFFILIATE ("AVAYA").

Avaya grants You a license within the scope of the license types described below, with the exception of Heritage Nortel Software, for which the scope of the license is detailed below. Where the order documentation does not expressly identify a license type, the applicable license will be a Designated System License. The applicable number of licenses and units of capacity for which the license is granted will be one (1), unless a different number of licenses or units of capacity is specified in the documentation or other materials available to You. "Software" means computer programs in object code, provided by Avaya or an Avaya Channel Partner, whether as stand-alone products, pre-installed on hardware products, and any upgrades, updates, patches, bug fixes, or modified versions thereto. "Designated Processor" means a single stand-alone computing device. "Server" means a Designated Processor that hosts a software application to be accessed by multiple users. "Instance" means a single copy of the Software executing at a particular time: (i) on one physical machine; or (ii) on one deployed software virtual machine ("VM") or similar deployment.

## License types

Designated System(s) License (DS). End User may install and use each copy or an Instance of the Software only on a number of Designated Processors up to the number indicated in the order. Avaya may require the Designated Processor(s) to be identified in the order by type, serial number, feature key, Instance, location or other specific designation, or to be provided by End User to Avaya through electronic means established by Avaya specifically for this purpose.

## Heritage Nortel Software

"Heritage Nortel Software" means the software that was acquired by Avaya as part of its purchase of the Nortel Enterprise Solutions Business in December 2009. The Heritage Nortel Software is the software contained within the list of Heritage Nortel Products located at <https://support.avaya.com/LicenseInfo> under the link "Heritage Nortel Products" or such successor site as designated by Avaya. For Heritage Nortel Software, Avaya grants Customer a license to use Heritage Nortel Software provided hereunder solely to the extent of the authorized activation or authorized usage level, solely for the purpose specified in the Documentation, and solely as embedded in, for execution on, or for communication with Avaya equipment. Charges for Heritage Nortel Software may be based on extent of activation or use authorized as specified in an order or invoice.

## Copyright

Except where expressly stated otherwise, no use should be made of materials on this site, the Documentation, Software, Hosted Service, or hardware provided by Avaya. All content on this site, the

documentation, Hosted Service, and the product provided by Avaya including the selection, arrangement and design of the content is owned either by Avaya or its licensors and is protected by copyright and other intellectual property laws including the sui generis rights relating to the protection of databases. You may not modify, copy, reproduce, republish, upload, post, transmit or distribute in any way any content, in whole or in part, including any code and software unless expressly authorized by Avaya. Unauthorized reproduction, transmission, dissemination, storage, and or use without the express written consent of Avaya can be a criminal, as well as a civil offense under the applicable law.

### Virtualization

The following applies if the product is deployed on a virtual machine. Each product has its own ordering code and license types. Note that each Instance of a product must be separately licensed and ordered. For example, if the end user customer or Avaya Channel Partner would like to install two Instances of the same type of products, then two products of that type must be ordered.

### Third Party Components

"Third Party Components" mean certain software programs or portions thereof included in the Software or Hosted Service may contain software (including open source software) distributed under third party agreements ("Third Party Components"), which contain terms regarding the rights to use certain portions of the Software ("Third Party Terms"). As required, information regarding distributed Linux OS source code (for those products that have distributed Linux OS source code) and identifying the copyright holders of the Third Party Components and the Third Party Terms that apply is available in the products, Documentation or on Avaya's website at: <https://support.avaya.com/Copyright> or such successor site as designated by Avaya. The open source software license terms provided as Third Party Terms are consistent with the license rights granted in these Software License Terms, and may contain additional rights benefiting You, such as modification and distribution of the open source software. The Third Party Terms shall take precedence over these Software License Terms, solely with respect to the applicable Third Party Components to the extent that these Software License Terms impose greater restrictions on You than the applicable Third Party Terms.

The following applies only if the H.264 (AVC) codec is distributed with the product. THIS PRODUCT IS LICENSED UNDER THE AVC PATENT PORTFOLIO LICENSE FOR THE PERSONAL USE OF A CONSUMER OR OTHER USES IN WHICH IT DOES NOT RECEIVE REMUNERATION TO (i) ENCODE VIDEO IN COMPLIANCE WITH THE AVC STANDARD ("AVC VIDEO") AND/OR (ii) DECODE AVC VIDEO THAT WAS ENCODED BY A CONSUMER ENGAGED IN A PERSONAL ACTIVITY AND/OR WAS OBTAINED FROM A VIDEO PROVIDER LICENSED TO PROVIDE AVC VIDEO. NO LICENSE IS GRANTED OR SHALL BE IMPLIED FOR ANY OTHER USE. ADDITIONAL INFORMATION MAY BE OBTAINED FROM MPEG LA, L.L.C. SEE [HTTP://WWW.MPEGLA.COM](http://www.mpegla.com).

### Service Provider

THE FOLLOWING APPLIES TO AVAYA CHANNEL PARTNER'S HOSTING OF AVAYA PRODUCTS OR SERVICES. THE PRODUCT OR HOSTED SERVICE MAY USE THIRD PARTY COMPONENTS SUBJECT TO THIRD PARTY TERMS AND REQUIRE A SERVICE PROVIDER TO BE INDEPENDENTLY LICENSED DIRECTLY FROM THE THIRD PARTY SUPPLIER. AN AVAYA CHANNEL PARTNER'S HOSTING OF AVAYA PRODUCTS MUST BE AUTHORIZED IN WRITING BY AVAYA AND IF THOSE HOSTED PRODUCTS USE OR EMBED CERTAIN THIRD PARTY SOFTWARE, INCLUDING BUT NOT LIMITED TO MICROSOFT SOFTWARE OR CODECS, THE AVAYA CHANNEL PARTNER IS REQUIRED TO INDEPENDENTLY OBTAIN ANY APPLICABLE LICENSE AGREEMENTS, AT THE AVAYA CHANNEL PARTNER'S EXPENSE, DIRECTLY FROM THE APPLICABLE THIRD PARTY SUPPLIER.

WITH RESPECT TO CODECS, IF THE AVAYA CHANNEL PARTNER IS HOSTING ANY PRODUCTS THAT USE OR EMBED THE G.729 CODEC, H.264 CODEC, OR H.265 CODEC, THE AVAYA CHANNEL PARTNER ACKNOWLEDGES AND AGREES THE AVAYA CHANNEL PARTNER IS RESPONSIBLE FOR ANY AND ALL RELATED FEES AND/OR ROYALTIES. THE G.729 CODEC IS LICENSED BY SIPRO LAB TELECOM INC. SEE

[WWW.SIPRO.COM/CONTACT.HTML](http://WWW.SIPRO.COM/CONTACT.HTML). THE H.264 (AVC) CODEC IS LICENSED UNDER THE AVC PATENT PORTFOLIO LICENSE FOR THE PERSONAL USE OF A CONSUMER OR OTHER USES IN WHICH IT DOES NOT RECEIVE REMUNERATION TO: (I) ENCODE VIDEO IN COMPLIANCE WITH THE AVC STANDARD ("AVC VIDEO") AND/OR (II) DECODE AVC VIDEO THAT WAS ENCODED BY A CONSUMER ENGAGED IN A PERSONAL ACTIVITY AND/OR WAS OBTAINED FROM A VIDEO PROVIDER LICENSED TO PROVIDE AVC VIDEO. NO LICENSE IS GRANTED OR SHALL BE IMPLIED FOR ANY OTHER USE. ADDITIONAL INFORMATION FOR H.264 (AVC) AND H.265 (HEVC) CODECS MAY BE OBTAINED FROM MPEG LA, L.L.C. SEE [HTTP://WWW.MPEGLA.COM](http://WWW.MPEGLA.COM).

### Compliance with Laws

You acknowledge and agree that it is Your responsibility for complying with any applicable laws and regulations, including, but not limited to laws and regulations related to call recording, data privacy, intellectual property, trade secret, fraud, and music performance rights, in the country or territory where the Avaya product is used.

### Preventing Toll Fraud

"Toll Fraud" is the unauthorized use of your telecommunications system by an unauthorized party (for example, a person who is not a corporate employee, agent, subcontractor, or is not working on your company's behalf). Be aware that there can be a risk of Toll Fraud associated with your system and that, if Toll Fraud occurs, it can result in substantial additional charges for your telecommunications services.

### Avaya Toll Fraud intervention

If You suspect that You are being victimized by Toll Fraud and You need technical assistance or support, call Technical Service Center Toll Fraud Intervention Hotline at +1-800-643-2353 for the United States and Canada. For additional support telephone numbers, see the Avaya Support website: <https://support.avaya.com> or such successor site as designated by Avaya.

### Security Vulnerabilities

Information about Avaya's security support policies can be found in the Security Policies and Support section of <https://support.avaya.com/security>.

Suspected Avaya product security vulnerabilities are handled per the Avaya Product Security Support Flow (<https://support.avaya.com/css/P8/documents/100161515>).

### Downloading Documentation

For the most current versions of Documentation, see the Avaya Support website: <https://support.avaya.com>, or such successor site as designated by Avaya.

### Contact Avaya Support

See the Avaya Support website: <https://support.avaya.com> for product or Hosted Service notices and articles, or to report a problem with your Avaya product or Hosted Service. For a list of support telephone numbers and contact addresses, go to the Avaya Support website: <https://support.avaya.com> (or such successor site as designated by Avaya), scroll to the bottom of the page, and select Contact Avaya Support.

### Trademarks

The trademarks, logos and service marks ("Marks") displayed in this site, the Documentation, Hosted Service(s), and product(s) provided by Avaya are the registered or unregistered Marks of Avaya, its affiliates, its licensors, its suppliers, or other third parties. Users are not permitted to use such Marks without prior written consent from Avaya or such third party which may own the Mark. Nothing contained in this site, the Documentation, Hosted Service(s) and product(s) should be construed as granting, by implication, estoppel, or otherwise, any license or right in and to the Marks without the express written permission of Avaya or the applicable third party.

Avaya is a registered trademark of Avaya Inc.

All non-Avaya trademarks are the property of their respective owners. Linux® is the registered trademark of Linus Torvalds in the U.S. and other countries.

# Contents

<b>Chapter 1: Introduction</b> .....	5
Purpose.....	5
<b>Chapter 2: New in this document</b> .....	6
<b>Chapter 3: Preinstallation checklist</b> .....	7
<b>Chapter 4: Installation preparation</b> .....	9
Ethernet Routing Switch 5900 series models.....	9
Electrostatic discharge prevention.....	15
Technical specifications.....	16
Power specifications.....	18
MTBF values.....	21
AC power cord specifications.....	22
Cooling fans and power supplies.....	24
Installing the fan trays and power supply.....	26
Connecting AC power.....	29
<b>Chapter 5: Switch installation</b> .....	31
Installing ERS 5900 switch in an equipment rack.....	32
Installing ERS 59100GTS and ERS 59100GTS-PWR+ in an equipment rack.....	34
Installing the switch using optional four-post rack-mount brackets.....	38
Single and multiple switch arrangements.....	42
Stack configuration.....	50
Connecting a transceiver to the switch or switch stack.....	52
Supported optical devices .....	53
Checking status LEDs to verify switch installation.....	57
IP address information configuration.....	61
<b>Chapter 6: Installation reference</b> .....	65
Console and management connections.....	65
RJ-45 connector pin assignments.....	66
Avaya Ethernet Routing Switch 5900 Series PoE.....	67
<b>Chapter 7: Resources</b> .....	68
Support.....	68
Searching a documentation collection.....	69
Subscribing to e-notifications.....	70
<b>Appendix A: Translations of safety messages</b> .....	73
Safety messages.....	73

# Chapter 1: Introduction

---

## Purpose

This document provides the information and procedures required to install the hardware, software, cabling, and power for the Ethernet Routing Switch 5900 Series.

Unless otherwise indicated, this information applies to:

- Ethernet Routing Switch 5928GTS
- Ethernet Routing Switch 5928GTS-PWR+
- Ethernet Routing Switch 5928GTS-uPWR
- Ethernet Routing Switch 5952GTS
- Ethernet Routing Switch 5952GTS-PWR+
- Ethernet Routing Switch 59100GTS
- Ethernet Routing Switch 59100GTS-PWR+

# Chapter 2: New in this document

The following sections detail what is new in *Installing Avaya Ethernet Routing Switch 5900 Series*, NN47211-300.

## **ERS 59100GTS**

ERS 59100GTS is the new switch added to ERS 5900 Series. The switch supports 96 10/100/1000 Base-T RJ-45 ports, where each port is capable of supporting four SFP+ (10 Gbps) ports.

## **ERS 59100GTS-PWR+**

ERS 59100GTS-PWR+ is the new switch added to ERS 5900 Series. The switch supports 96 ports of 10/100/1000 Ethernet, where each port is capable of supporting PoE+ (30 W) along with four SFP+ (10 Gbps) ports.

For more information, see the following:

- [Ethernet Routing Switch 5900 series models](#) on page 9
- [Technical specifications](#) on page 16
- [Installing ERS 59100GTS and ERS 59100GTS-PWR+ in an equipment rack](#) on page 34

## **Stacking bandwidth**

The stacking bandwidth value is corrected.

For more information, see [Single and multiple switch arrangements](#) on page 42.

## **Resources**

Information about related resources is moved to the last chapter in this document.

# Chapter 3: Preinstallation checklist

Before you install the Avaya Ethernet Routing Switch 5900 Series, make sure that you complete the tasks in the preinstallation checklist.

No.	Task	Description	✓
1.	Review the technical specification for the switch. Make sure that the area where you install the switch and where it will operate meet the requirements.	For the physical, electrical, and environmental specifications, see <a href="#">Technical specifications</a> on page 16. .	
2.	Verify the power supply unit (PSU) specifications. Optionally order a redundant PSU to provide redundancy and load sharing.	See <a href="#">AC power specifications</a> on page 18.	
3.	Make sure that you have the following tools and cables: <ul style="list-style-type: none"> <li>• Phillips #2 screwdriver</li> <li>• RJ-45 console port cable</li> <li>• ESD cable</li> </ul>	See <a href="#">Identifying cables to use with the Ethernet Routing Switch</a> on page 51.	
4.	Unpack the equipment.	Observe ESD precautions when you unpack the equipment. See <a href="#">Electrostatic discharge prevention</a> on page 15.	
5.	Verify the contents of the shipped package.	See <a href="#">Verifying the package contents</a> on page 22 for a description of the components that are provided with the switch. If any components are missing, contact Avaya support at <a href="https://support.avaya.com/">https://support.avaya.com/</a> .	
6.	Make sure that the power cord has the correct country-specific termination.	See <a href="#">AC power cord specifications</a> on page 22.	
7	Prepare the rack.	Ensure that there is enough rack space of 1.75 inches (4.45 centimeters).  Ensure that the rack is bolted to the floor and braced if necessary.	

*Table continues...*

Preinstallation checklist

No.	Task	Description	✓
		<p>Ensure that the rack is grounded to the same grounding electrode used by the power service in the area. The ground path must be permanent and must not exceed 1 Ohm of resistance from the rack to the grounding electrode.</p> <p>Depending on the switch model, see <a href="#">Installing ERS 5900 switch in an equipment rack</a> on page 32 or <a href="#">Installing ERS 59100GTS and ERS 59100GTS-PWR+ in an equipment rack</a> on page 34.</p>	



# Chapter 4: Installation preparation

## Ethernet Routing Switch 5900 series models

The following table lists the different Ethernet Routing Switch 5900 Series models and the key features for each switch.

**Table 1: 5900 Series Switch Platforms**

5900 Series Switch Model	Key features	Part Number
Ethernet Routing Switch 5928GTS	<ul style="list-style-type: none"> <li>• 24 10/100/1000 Base-T RJ-45 ports</li> <li>• Four SFP+ 1/10 Gbps uplink ports</li> <li>• Non-PoE</li> <li>• Layer 2/Layer 3</li> <li>• Stackable Ethernet switch</li> <li>• 1 rack unit (U) high</li> <li>• Uses modular power supply units and has two field-serviceable power supply receptacles, which support 450 W AC power supply modules.</li> </ul>	AL590001X-E6 (no power supply unit (PSU), no power cord (PC)) AL5900A1B-E6 (no PC) AL5900A1F-E6 (no PC) AL5900B1B-E6 (EU PC) AL5900B1F-E6 (EU PC) AL5900C1B-E6 (UK PC) AL5900C1F-E6 (UK PC) AL5900D1B-E6 (Japan PC) AL5900D1F-E6 (Japan PC) AL5900E1B-E6 (NA PC) AL5900E1F-E6 (NA PC) AL5900F1B-E6 (ANZ PC) AL5900F1F-E6 (ANZ PC)
Ethernet Routing Switch 5928GTS-PWR+	<ul style="list-style-type: none"> <li>• 24 10/100/1000 Base-T RJ-45 ports with 802.3at PoE+</li> <li>• Four SFP+ 1/10 Gbps uplink ports</li> <li>• Layer 2/Layer 3</li> <li>• Stackable Ethernet switch</li> <li>• 1 rack unit (U) high</li> <li>• Uses modular power supply units and has two field-serviceable</li> </ul>	AL590002X-E6 (no PSU, no PC) AL5900A2B-E6 (no PC) AL5900A2F-E6 (no PC) AL5900B2B-E6 (EU PC) AL5900B2F-E6 (EU PC) AL5900C2B-E6 (UK PC)

*Table continues...*

5900 Series Switch Model	Key features	Part Number
	power supply receptacles, which support 1400 W AC power supply modules.	AL5900C2F-E6 (UK PC) AL5900D2B-E6 (Japan PC) AL5900D2F-E6 (Japan PC) AL5900E2B-E6 (NA PC) AL5900E2F-E6 (NA PC) AL5900F2B-E6 (ANZ PC) AL5900F2F-E6 (ANZ PC)
Ethernet Routing Switch 5928GTS-uPWR	<ul style="list-style-type: none"> <li>• 24 10/100/1000 Base-T RJ-45 ports with 802.3at PoE+</li> <li>• Four SFP+ 1/10 Gbps uplink ports</li> <li>• Layer 2/Layer 3</li> <li>• Stackable Ethernet switch</li> <li>• 1 rack unit (U) high</li> <li>• Uses modular power supply units and has two field-serviceable power supply receptacles, which support 1400 W AC power supply modules.</li> </ul>	AL5900A7x-E6 (no PSU, no PC) AL5900A7B-E6 (No PC) AL5900A7F-E6 (No PC) AL5900B7B-E6 (EU PC) AL5900B7F-E6 (EU PC) AL5900C7B-E6 (UK PC) AL5900C7F-E6 (UK PC) AL5900D7B-E6 (JP PC) AL5900D7F-E6 (JP PC) AL5900E7B-E6 (NA PC) AL5900E7F-E6 (NA PC) AL5900F7B-E6 (ANZ PC) AL5900F7F-E6 (ANZ PC)
Ethernet Routing Switch 5952GTS	<ul style="list-style-type: none"> <li>• 48 10/100/1000 Base-T RJ-45 ports</li> <li>• Four SFP+ 1/10 Gbps uplink ports</li> <li>• Non-PoE</li> <li>• Layer 2/Layer 3</li> <li>• Stackable Ethernet switch</li> <li>• 1 rack unit (U) high</li> <li>• Uses modular power supply units and has two field-serviceable power supply receptacles, which support 450 W AC power supply modules.</li> </ul>	AL590003X-E6 (no PSU, no PC) AL5900A3B-E6 (no PC) AL5900A3F-E6 (no PC) AL5900B3B-E6 (EU PC) AL5900B3F-E6 (EU PC) AL5900C3B-E6 (UK PC) AL5900C3F-E6 (UK PC) AL5900D3B-E6 (Japan PC) AL5900D3F-E6 (Japan PC) AL5900E3B-E6 (NA PC) AL5900E3F-E6 (NA PC)

*Table continues...*

5900 Series Switch Model	Key features	Part Number
		AL5900F3B-E6 (ANZ PC) AL5900F3F-E6 (ANZ PC)
Ethernet Routing Switch 5952GTS-PWR+	<ul style="list-style-type: none"> <li>• 48 10/100/1000 Base-T RJ-45 ports with 802.3at PoE+</li> <li>• Four SFP+ 1/10 Gbps uplink ports</li> <li>• Layer 2/Layer 3</li> <li>• Stackable Ethernet switch</li> <li>• 1 rack unit (U) high</li> <li>• Uses modular power supply units and has two field-serviceable power supply receptacles, which support 1400 W AC power supply modules.</li> </ul>	AL590004X-E6 (no PSU, no PC) AL5900A4B-E6 (no PC) AL5900A4F-E6 (no PC) AL5900B4B-E6 (EU PC) AL5900B4F-E6 (EU PC) AL5900C4B-E6 (UK PC) AL5900C4F-E6 (UK PC) AL5900D4B-E6 (Japan PC) AL5900D4F-E6 (Japan PC) AL5900E4B-E6 (NA PC) AL5900E4F-E6 (NA PC) AL5900F4B-E6 (ANZ PC) AL5900F4F-E6 (ANZ PC)
Ethernet Routing Switch 59100GTS	<ul style="list-style-type: none"> <li>• 96 10/100/1000 Base-T RJ-45 ports</li> <li>• Four SFP+ 1/10 Gbps uplink ports</li> <li>• Stackable Ethernet switch</li> <li>• Layer 2/Layer 3</li> <li>• Non-PoE</li> <li>• 1 rack unit (U) high</li> <li>• Uses modular power supply units and has four field-serviceable power supply receptacles, which support 450 W AC power supply modules.</li> </ul>	AL5900A5x-E6 (no PSU, no PC) AL5900A5B-E6 (no PC) AL5900A5F-E6 (no PC) AL5900B5B-E6 (EU PC) AL5900B5F-E6 (EU PC) AL5900C5B-E6 (UK PC) AL5900C5F-E6 (UK PC) AL5900D5B-E6 (JP PC) AL5900D5F-E6 (JP PC) AL5900E5B-E6 (NA PC) AL5900E5F-E6 (NA PC) AL5900F5B-E6 (ANZ PC) AL5900F5F-E6 (ANZ PC)
Ethernet Routing Switch 59100GTS-PWR+	<ul style="list-style-type: none"> <li>• 96 10/100/1000 Base- T RJ45 ports with 802.3at PoE+</li> <li>• Four SFP+ 1/10 Gbps uplink ports</li> </ul>	AL5900A6x-E6 no PSU, no PC) AL5900A6B-E6 (no PC) AL5900A6F-E6 (no PC)

*Table continues...*

5900 Series Switch Model	Key features	Part Number
	<ul style="list-style-type: none"> <li>• Layer 2/Layer 3</li> <li>• Stackable Ethernet switch</li> <li>• 1 rack unit (U) high</li> <li>• Uses modular power supply units and has four field-serviceable power supply receptacles, which support 1400 W AC power supply modules.</li> </ul>	AL5900B6B-E6 (EU PC) AL5900B6F-E6 (EU PC) AL5900C6B-E6 (UK PC) AL5900C6F-E6 (UK PC) AL5900D6B-E6 (JP PC) AL5900D6F-E6 (JP PC) AL5900E6B-E6 (NA PC) AL5900E6F-E6 (NA PC) AL5900F6B-E6 (ANZ PC) AL5900F6F-E6 (ANZ PC)
<p><b>* Note:</b>                      The 'B' in the part number (e.g. AL5900E4<b>B</b>-E6) denotes Back to Front cooling, whereas 'F' denotes Front to Back cooling (e.g. AL5900E4<b>F</b>-E6).</p>		

## Common hardware features

The following hardware features are part of all 5900 Series switches:

- One RJ-45 RS-232 Console connection at the front (note jack orientation)
- Two FRU Fan Tray modules

**\* Note:**

ERS 59100GTS and ERS 59100GTS-PWR+ support four Fan Tray modules.

- Standard ERS 19 inch rack mount hole pattern allowing horizontal or vertical, flush or offset, front or rear mount options
- One rear panel mounted Ethernet out-of-band management port
- One rear mounted Base Select Switch
- Support for two field replaceable power supply units

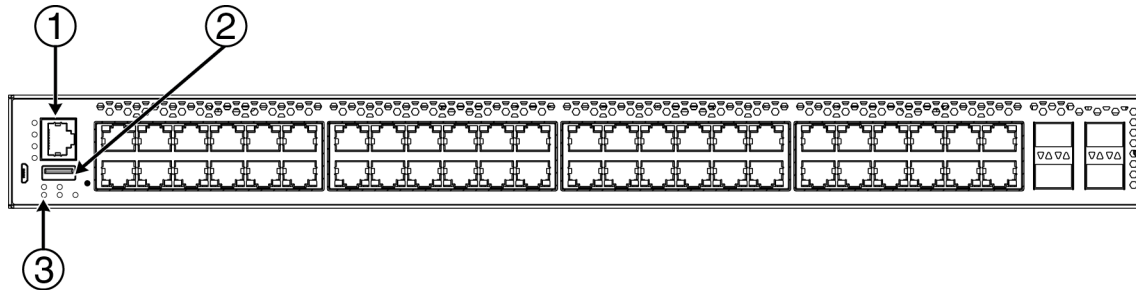
**\* Note:**

ERS 59100GTS and ERS 59100GTS-PWR+ support four field replaceable power supply units.

- One Kensington Lock slot located on the left side, near the back end of the chassis
- Two QSFP+ style stacking ports each supporting 42 Gbps of bidirectional traffic
- Status LED display panel
- One USB 2.1 Type A port
- One micro-USB 2.1 Type B port (reserved)

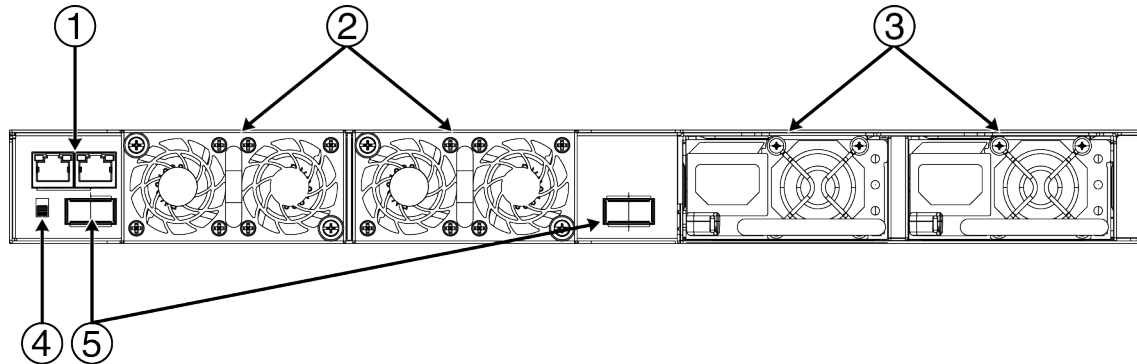
- Two 10/100/1000 Mbps copper ports (diagnostic use only)

The following figure shows the front panel of the 5932GTS switch.



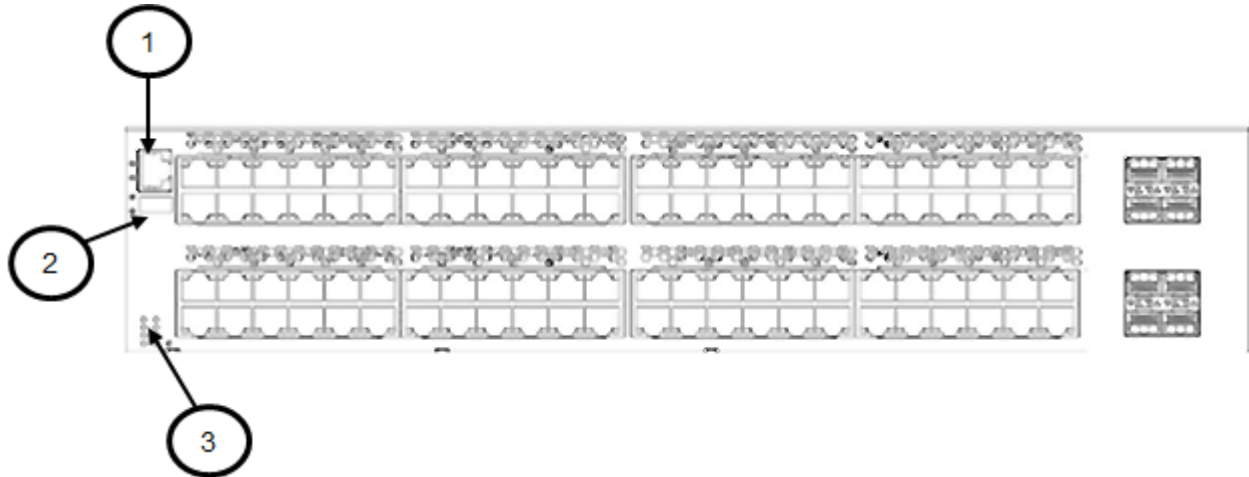
1. Console port
2. USB 2.1 Type-A port
3. LED display

The following figure shows the rear panel of the 5932GTS switch.



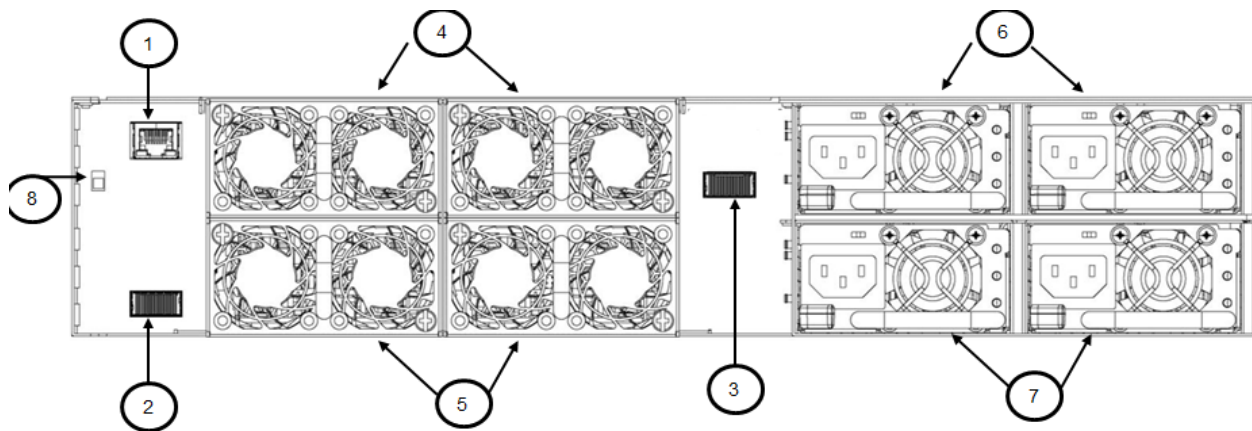
1. Diagnostic ports (SDN port (labelled as AUX cannot be enabled) and out-of-band management port)
2. Fan tray units
3. Power supply units
4. Base Unit switch
5. QSFP ports for stacking

The following figure shows the front panel of the 59100GTS switch.



- 1. Console port
- 2. USB 2.1 Type-A port
- 3. LED display

The following figure shows the rear panel of the 59100GTS switch.



- 1. Diagnostic port (SDN port (labelled as AUX cannot be enabled) and out-of-band management port)
- 2 and 3. QSFP ports for stacking
- 4 and 5. Fan tray units
- 6 and 7. Power supply units
- 8. Base Unit switch

## Universal Serial Bus ports on the Avaya Ethernet Routing Switch 5900 Series

The ERS 5900 switches include a USB Type A port on the front panel adjacent to the console port, as well as a micro-USB Type B port.

The USB Type A port enables switch administrators to perform tasks that were previously completed through TFTP with a commonly available USB Mass Storage Device (also known as a flash drive or thumb drive). These tasks include:

- software download
- syslog backup
- ASCII configuration file generation and download

File and system operations are limited by the size of the USB device in use. Only USB drives that comply with the Mass Storage sub-section of the USB 1.1, USB 2.0, and USB 2.1 specification are supported. Support is not extended to third-party devices that do not comply with these standards. Consult the documentation provided with the USB drive to ensure compliance with these standards.

**!** **Important:**

The micro-USB port on the front panel of the Ethernet Routing Switch 5900 Series models is not enabled.

---

## Electrostatic discharge prevention

This module provides information and procedures for the prevention of electrostatic discharge during the installation process.

Electrostatic discharge (ESD) is a discharge of stored static electricity that can damage equipment and impair electrical circuitry. These electrostatic voltages can result from friction, including, but not exclusive to, pulling cabling through conduits, walking across carpeted areas, and building up of static charge in clothing. ESD damage occurs when electronic components are improperly handled and can result in complete or intermittent failures. While networking equipment is commonly designed and tested to withstand common mode ESD events, voltage sometimes can be discharged to some connector pins but not others, or to some pins before others, which has the potential to damage the networking equipment.

To protect the Avaya Ethernet Routing Switch against ESD damage, take the following preventive measures before connecting any data cables to the device:

- Always use antistatic wrist straps. Make sure the strap is adjusted to provide good skin contact.
- Ensure that work surfaces and equipment racks are properly grounded for protection against electrostatic discharge. The common point must be connected to the building ground wire. In a properly wired building, the nearest reliable ground is typically at the electrical outlet.
- Avoid contact between equipment and clothing. The wrist or ankle strap only protects the equipment from ESD voltages on the body; ESD voltages on clothing can still cause damage.
- Avoid touching any connector pins.
- Do not remove the wrist or ankle strap until the installation is complete.

With new cable installations, Avaya recommends that the use of an ESD discharge cable to reduce the potential for damage from static that can build up in cables. See the following figure.

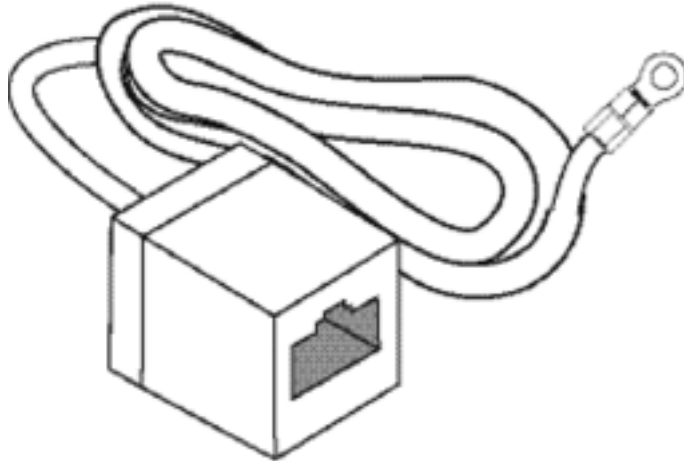


Figure 1: ESD cable

## Technical specifications

The following table provides the technical specifications for the individual switches in the Ethernet Routing Switch 5900 Series. Ensure that the area where you install the switch and where it operates meets these requirements.

**Warning:**

To avoid bodily injury from hazardous electrical shock and current, never remove the top of the device. No user-serviceable components are inside.

Table 2: Physical specifications

Specifications	5928GTS/5928GTS-PWR+/5928GTS-uPWR/5952GTS/5952GTS-PWR+/59100GTS/59100GTS-PWR+	✓
Height	<ul style="list-style-type: none"> <li>• 5928GTS/5928GTS-PWR+/5928GTS-uPWR/5952GTS/5952GTS-PWR+: 44 mm</li> <li>• 59100GTS/59100GTS-PWR+: 88.5 mm</li> </ul>	
Width	442 mm	
Depth	456 mm, 488 mm at the power supply.	
Weight (includes switch weight with 1 PSU and the required fan trays.	<ul style="list-style-type: none"> <li>• 5928GTS: 7.6 kg</li> <li>• 5928GTS-PWR+: 8.2</li> <li>• 5928GTS-uPWR: 8.3 kg</li> <li>• 5952GTS: 8.1 kg</li> <li>• 5952GTS-PWR+: 8.6 kg</li> <li>• 59100GTS: 11.9 kg</li> </ul>	

Table continues...



<b>Specifications</b>	<b>5928GTS/5928GTS-PWR+/5928GTS-uPWR/5952GTS/5952GTS-PWR+/59100GTS/59100GTS-PWR+</b>	✓
	<ul style="list-style-type: none"> <li>• 59100GTS-PWR+: 12.9 kg</li> </ul>	
Weight of spare AC power supply unit	<ul style="list-style-type: none"> <li>• PWR-450W: 1.17 kg</li> <li>• PWR-1400W: 1.32 kg</li> </ul>	

**Table 3: Electrical specifications**

Power consumption	Refer to table in section <a href="#">AC power specifications</a> on page 18.
Thermal rating	Refer to table in section <a href="#">AC power specifications</a> on page 18.
MTBF rating	<ul style="list-style-type: none"> <li>• 5928GTS — Single PSU: 248,758 hours, Dual PSU: 199,203 hours</li> <li>• 5928GTS-PWR+ — Single PSU: 246,741 hours, Dual PSU: 208,803 hours</li> <li>• 5928GTS-uPWR — Single PSU: 254,165 hours, Dual PSU: 214,112 hours</li> <li>• 5952GTS — Single PSU: 241,078 hours, Dual PSU: 194,249 hours</li> <li>• 5952GTS-PWR+ — Single PSU: 239,731 hours, Dual PSU: 203,776 hours</li> <li>• 59100GTS — Single PSU: 150,386 hours, Dual PSU: 130,727 hours, Triple PSU: 115,613 hours, Quadruple PSU: 103,632 hours</li> <li>• 59100GTS-PWR+ — Single PSU: 145,094 hours, Dual PSU: 131,088 hours, Triple PSU: 119,448 hours, Quadruple PSU: 109,875 hours</li> </ul>

**Table 4: Environmental specifications**

Operating Temperature	0° to 50°C (32° to 122°F)
Storage Temperature	-40° to 85°C (-40° to 185°F)
Operating Humidity	0 to 95 percent non-condensing
Storage Humidity	10 to 95 percent non-condensing
Maximum Operating Altitude	3048 m (10,000 feet)
Storage Altitude	-304.8 to 12,192 m (-1,000 to 40,000 feet) above sea level
Acoustic Noise	At 25°C Ambient Temperature, less than 52 dBA typical, at 50°C, less than 60 dBA.  The system should never exceed 70dBA.
Miscellaneous Operating Considerations	<ul style="list-style-type: none"> <li>• No heat sources such as hot air vents or direct sunlight located near the switch</li> <li>• No sources of severe electromagnetic interference located near the switch.</li> </ul>

*Table continues...*

	<ul style="list-style-type: none"> <li>• No excessive dust in the environment.</li> <li>• An adequate power source is located within 6 feet (1.83 meters) of the switch. One 15-amp circuit is required for each power supply.</li> <li>• At least 2 inches (5 centimeters) on all sides of the switch unit for ventilation</li> <li>• Cables should be dressed to prevent blocking air flow.</li> <li>• Adequate clearance is allotted at the front and rear of the switch for access to cables.</li> </ul>
--	--

## Power specifications

This section provides the following specifications for Ethernet Routing Switch 5900 Series:

- [AC power specifications](#) on page 18
- [Typical power consumption](#) on page 20
- [PoE+ specifications](#) on page 21

The following table describes the AC power specifications.

**Table 5: AC power specifications**

Model	Power supply configuration	Power supply		Input power (margined by 10%)		Power consumption (Thermal rating)	
		Rated	Line voltage	Watts (Total)	Amps	Watts	BTUs/hr
ERS 5928GTS	Dual supply (450 W/PSU)	450 W/PSU	100–120 VAC	77.4	0.7	77.4	264
	Single supply (450 W)			53.9	0.48	53.9	183.9
	Dual supply (450 W/PSU)	450 W/PSU	200–240 VAC	77.2	0.43	77.2	263.4
	Single supply (450 W)			53.7	0.29	53.7	183.3
ERS 5928GTS-PWR+	Dual supply (1000 W/PSU)	1000 W/PSU	100–120 VAC	858	7.52	137	467.4
	Single supply (1000 W)			851	7.4	131	447
	Dual supply (1400 W/PSU)	1400 W/PSU	200–240 VAC	846	3.77	126	429.9
	Single supply (1400 W)			824.4	3.61	103.4	352.6

*Table continues...*

Model	Power supply configuration	Power supply		Input power (margined by 10%)		Power consumption (Thermal rating)	
		Rated	Line voltage	Watts (Total)	Amps	Watts	BTUs/hr
ERS 5928GTS-uPWR	Dual supply (1000 W/PSU)	1000 W/PSU	100–120 VAC	1662	14.5	218	744
	Single supply (1000 W)			837	7.3	114	389
	Dual supply (1400 W/PSU)	1400 W/PSU	200–240 VAC	1616	7.1	172	588
	Single supply (1400 W)			1285	5.6	143	487
ERS 5952GTS	Dual supply (450 W/PSU)	450 W/PSU	100–120 VAC	90	0.78	90	307.1
	Single supply (450 W)			60.8	0.54	60.8	207.4
	Dual supply (450 W/PSU)	450 W/PSU	200–240 VAC	88.6	0.46	88.6	302.3
	Single supply (450 W)			61.6	0.32	61.6	210.3
ERS 5952GTS-PWR+	Dual supply (1000 W/PSU)	1000 W/PSU	100–120 VAC	1665	14.58	221	754.1
	Single supply (1000 W)			932.6	8.06	154.6	527.4
	Dual supply (1400 W/PSU)	1400 W/PSU	200–240 VAC	1662	7.12	176	600.5
	Single supply (1400 W)			1371.1	5.97	176.1	600.8
ERS 59100GTS	Single supply (450 W)	450 W/PSU	100–120 VAC	109.7	1.0	109.7	374.4
	Dual supply (450 W/PSU)			138.6	1.2	138.6	473.0
	Triple supply (450 W/PSU)			163.3	1.4	163.3	557.2
	Quad supply (450 W/PSU)			183.9	1.6	183.9	627.5
	Single supply (450 W)	450 W/PSU	200–240 VAC	107.3	0.5	107.3	366.2
	Dual supply (450 W/PSU)			137.3	0.7	137.3	468.6

Table continues...

Model	Power supply configuration	Power supply		Input power (margined by 10%)		Power consumption (Thermal rating)	
		Rated	Line voltage	Watts (Total)	Amps	Watts	BTUs/hr
	Triple supply (450 W/PSU)			162.2	0.8	162.2	553.4
	Quad supply (450 W/PSU)			182.6	1.0	182.6	623.1
ERS 59100GTS-PWR+	Single supply (1000 W)	1000 W/PSU	100–120 VAC	1182.5	10.3	192.4	656.6
	Dual supply (1000 W/PSU)			2338.7	20.3	353.3	1205.5
	Triple supply (1000 W/PSU)			3369.9	29.3	473.7	1616.2
	Quad supply (1000 W/PSU)			3327.2	29.0	432.0	1473.9
	Single supply (1400 W)	1400 W/PSU	200–240 VAC	1643.3	7.2	202.8	692.0
	Dual supply (1400 W/PSU)			3158.7	13.8	353.8	1203.7
	Triple supply (1400 W/PSU)			3227.7	14.1	330.5	1127.6
	Quad supply (1400 W/PSU)			3218.9	14.1	322.1	1099.0

The following table provides typical power consumption.

**Table 6: Typical power consumption**

Model	Idle Power consumption (Watts)	Typical Power consumption (Watts)		
		Devices connected to all ports, typical traffic, without SFPs	Devices connected to all ports, typical traffic, 6 W average per PoE device	With Avaya Energy Saver enabled (PoE Saver disabled on PoE models)
ERS 5928GTS	52.2	56.7	NA	52.2
ERS 5928GTS-PWR+	47.8	52.0	207.4	47.8
ERS 5928GTS-uPWR	46.0	50.7	210.6	45.9
ERS 5952GTS	60.4	69.0	NA	60.5
ERS 5952GTS-PWR+	56.5	65.6	373.59	56.5
ERS 59100GTS	92.0	111.0	NA	91.8
ERS 59100GTS-PWR+	97.1	117.7	748.5	97.1

The following table describes the Power over Ethernet (PoE+) specifications.

**Table 7: PoE+ specifications**

Model	Power supply configuration	Power supply		Power over Ethernet (PoE+) power output		
		Rated	Line voltage	Max Power per Port (Watts)	Max power output Sum of all Ports (Watts)	
ERS 5928GTS-PWR+	Dual supply (1000 W/PSU)	1000 W/PSU	100–120 VAC	30	720	24 ports @ 30 W
	Single supply (1000 W)			30		24 ports @ 30 W
	Dual supply (1400 W/PSU)	1400 W/PSU	200–240 VAC	30	720	24 ports @ 30 W
	Single supply (1400 W)			30		24 ports @ 30 W
ERS 5928GTS-uPWR	Dual supply (1000 W/PSU)	1000 W/PSU	100–120 VAC	60	1440	24 ports @ 60 W
	Single supply (1000 W)			60		720
	Dual supply (1400 W/PSU)	1400 W/PSU	200–240 VAC	60	1440	24 ports @ 60 W
	Single supply (1400 W)			60		1140
ERS 5952GTS-PWR+	Dual supply (1000 W/PSU)	1000 W/PSU	100–120 VAC	30	1440	48 ports @ 30 W
	Single supply (1000 W)			30		800
	Dual supply (1400 W/PSU)	1400 W/PSU	200–240 VAC	30	1440	48 ports @ 30 W
	Single supply (1400 W)			30		1200
ERS 59100GTS-PWR+	Dual supply (1000 W/PSU)	1000 W/PSU	100–120 VAC	30	2880	96 ports @ 30 W
	Dual supply (1400 W/PSU)	1400 W/PSU	200–240 VAC	30		96 ports @ 30 W

## MTBF values

The following table lists the MTBF values for the switches in ERS 5900 Series when two or four fans are used in combination with PSUs.

Model	Number of PSUs	Power Supply rating	MTBF (hours)
5928GTS	1	450 W	248,756
	2	450 W	199,203
5928GTS-PWR+	1	1400 W	246,741
	2	1400 W	208,803
5928GTS-uPWR	1	1400 W	254,165
	2	1400 W	214,112
5952GTS	1	450 W	241,078
	2	450 W	194,249
5952GTS-PWR+	1	1400 W	239,731
	2	1400 W	203,776
59100GTS	1	450 W	150,386
	2		130,727
	3		115,613
	4		103,632
59100GTS-PWR+	1	1400 W	145,094
	2		131,088
	3		119,548
	4		109,875

---

## AC power cord specifications

---

## Verifying the package contents

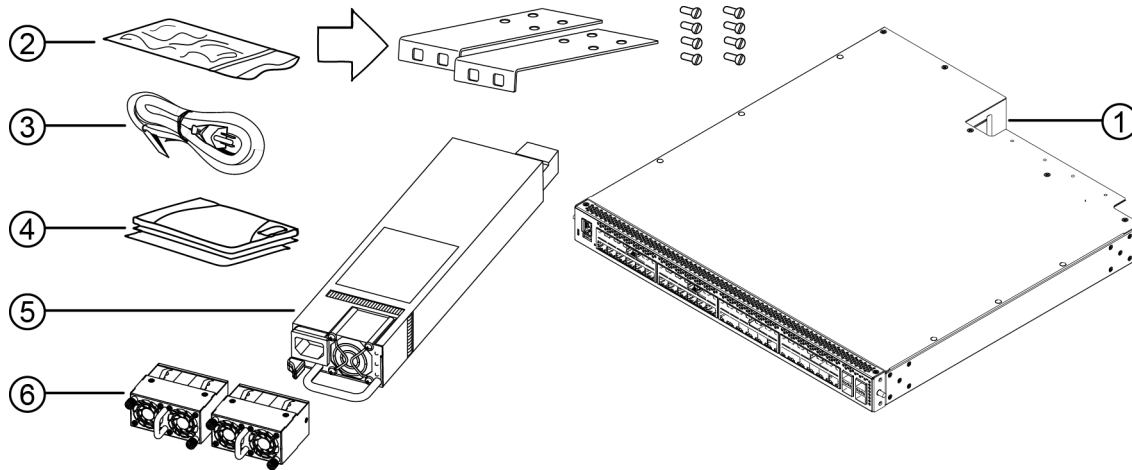
### About this task

Verify the package contents with the item list to ensure you have received all components. If components are missing, contact the vendor where you purchased the switch.

Depending on the switch model, see the following sections:

Switch Model	Section
ERS 5928GTS, ERS 5952GTS-PWR+, ERS 5928GTS-PWR+, ERS 5928GTS-uPWR	<a href="#">ERS 5900 switch package contents</a> on page 23
ERS 59100GTS, ERS 59100GTS-PWR+	<a href="#">ERS 59100 switch package contents</a> on page 24

## ERS 5900 switch package contents



**Figure 2:**

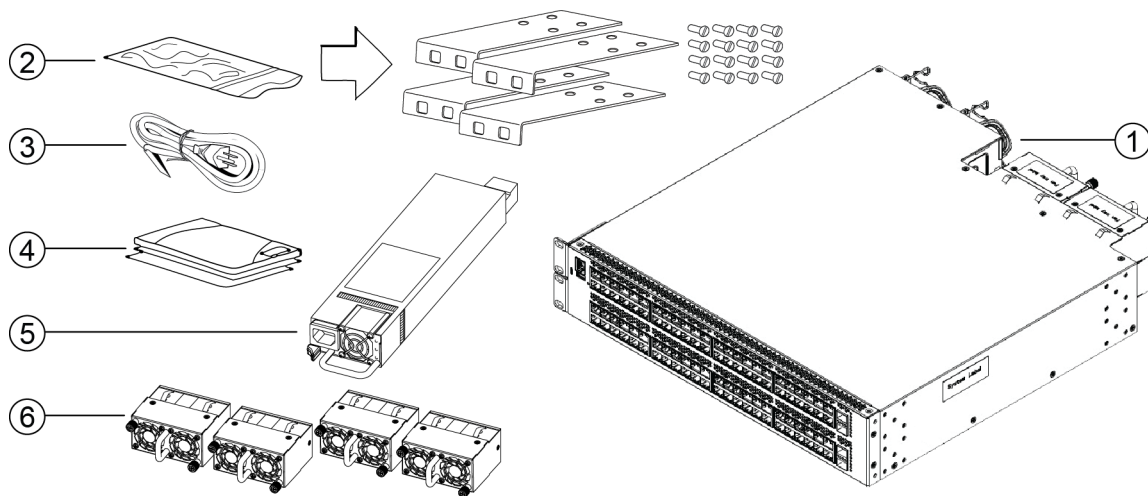
1. Avaya Ethernet Routing Switch 5900 Series
2. Rack-mounting hardware that includes:
  - Rack-mount brackets (two for a 19-inch equipment rack and two for a 23-inch equipment rack)
  - Screws for attaching brackets to the switch
3. Country-specific AC power cord (Note: A power cord is not included for the A variant of the switch.)
4. Documentation including the Quick Install poster and Regulatory document
5. One field replaceable power supply module (two power supplies are supported for models)
6. Two fan tray modules

**\* Note:**

Items 5 and 6 are not packaged with the switch. They are packed separately.

---

## ERS 59100 switch package contents



1. Avaya Ethernet Routing Switch 59100 Series
2. Rack-mounting hardware that includes:
  - Rack-mount brackets (two for a 19-inch equipment rack and two for a 23-inch equipment rack)
  - Screws for attaching brackets to the switch
3. Country-specific AC power cord (Note: A power cord is not included for the A variant of the switch.)
4. Documentation including the Quick Install poster and Regulatory document
5. One field replaceable power supply modules (four power supplies are supported by the switch models)
6. Four fan tray modules

**\* Note:**

Items 5 and 6 are not packaged with the switch. They are packed separately.

---

## Cooling fans and power supplies

Switch requires one fan tray and one power supply unit. To provide redundancy, the supported number of power supplies and fan trays can be installed.

The following table lists the switch model and the supported number of fan trays and power supply units:



**Table 8: Supported number of fan trays and power supply units**

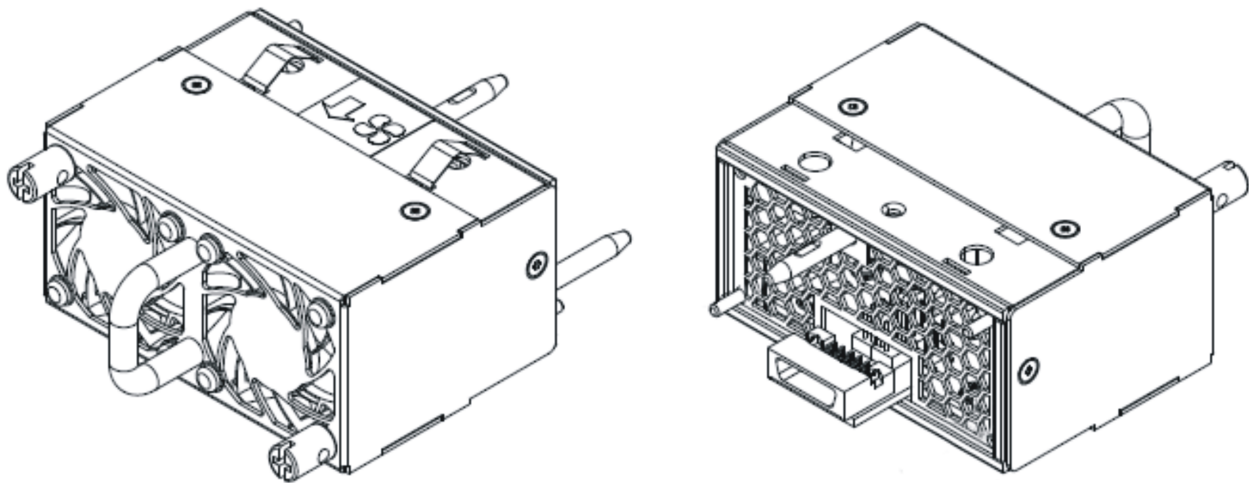
Switch Model	Supported number of fan trays	Supported number of power supply units
ERS 5928GTS, ERS 5952GTS-PWR+, ERS 5928GTS-PWR+, ERS 5928GTS-uPWR	2	2
ERS 59100GTS, ERS 59100GTS-PWR+	4	4

### Cooling fan trays

Cooling fan trays support hot-swap and are available in two models to support front to back, or back to front airflow modes. Cooling fan trays are included and must be installed before operating the switch.

The cooling system is designed to support normal operation over the specified operating range with a single fan failure. Note that fan noise may increase in this situation. The cooling system is also designed to operate for a brief period of time on a single fan tray, allowing replacement of a defective fan tray while the switch is operating.

The following figure shows cooling fan trays.



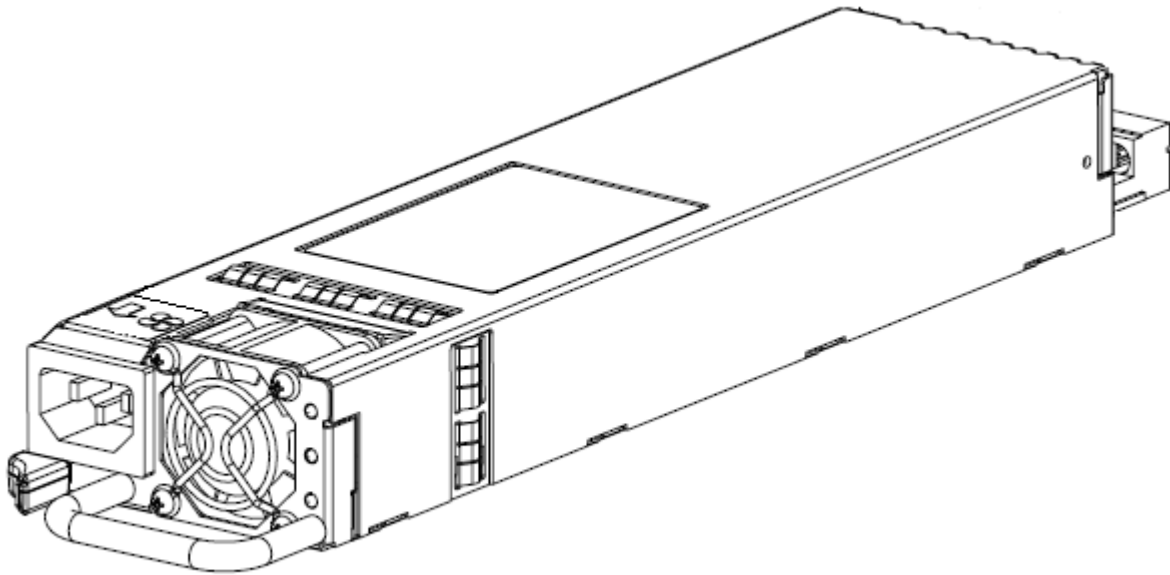
**Figure 3: Fan tray**

### Power supply compatibility with cooling fans

Power supplies support hot-swap and are available in two models to support cooling fan airflow modes.

If you are using front to back cooling or back to front cooling, ensure that you use compatible power supplies that match the cooling fan airflow.

The following figure shows AC power supply.



**Figure 4: AC power supply**

### **Redundant power supply configurations**

You can install two or four power supplies for redundancy and load sharing. You can hot-swap power supplies for nonstop, uninterrupted switch operation.

### **Power supply monitoring**

For enhanced monitoring, power supplies send information to the switch software about the type (AC and airflow mode).

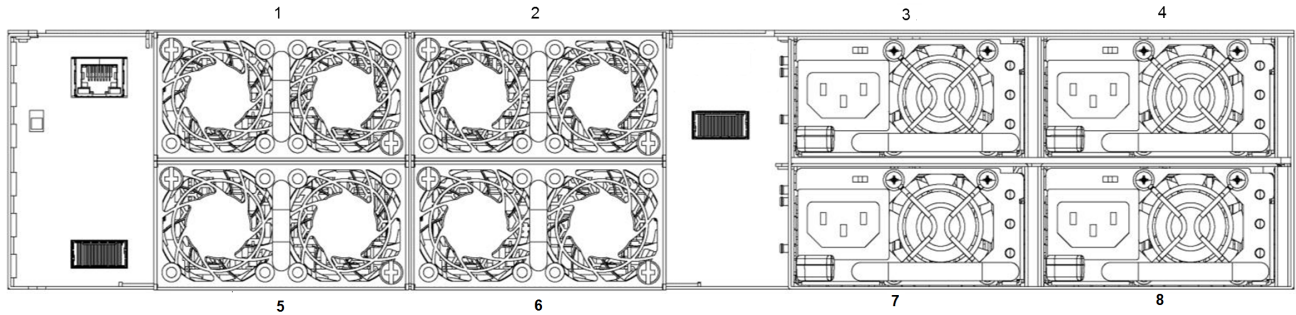
---

## **Installing the fan trays and power supply**

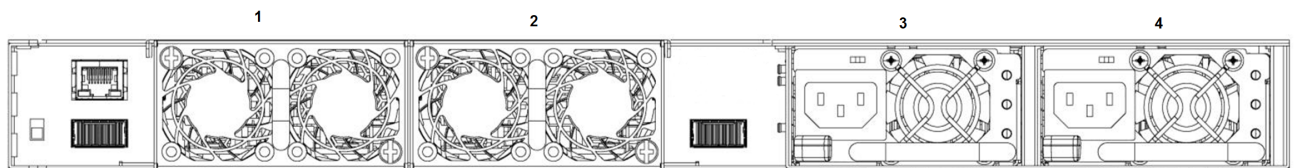
Your switch supports a combination of field-replaceable power supplies and cooling fan trays. Depending on the switch model, two or four trays are included with your switch. You must install the fan trays and at least one power supply before using the switch. The optional power supply unit can be installed for redundancy and load sharing.

For more information, see [Supported number of fan trays and power supplies](#) on page 25.

The following figures show fan trays and power supply location:



**Figure 5: ERS 59100GTS and ERS 59100GTS-PWR+ rear panel**



**Figure 6: ERS 5900 Series rear panel**

1	Fan Tray 2
2	Fan Tray 1
3	Power Supply Unit 1 (PS 1)
4	Power Supply Unit 2 (PS 2)
5	Fan Tray 4
6	Fan Tray 3
7	Power Supply Unit 3 (PS 3)
8	Power Supply Unit 4 (PS 4)

To install the fan trays and power supplies to your switch, use the following procedure.

**! Important:**

Supported cooling airflow directions are: front to back or back to front. The airflow direction of fan trays and power supplies are labelled and fixed. Ensure the fan trays and power supplies have the same direction of airflow.

The fan trays and power supplies do not support the ability to change their airflow direction. The first power supply determines the airflow direction.

In a single power supply installation, keep the blanking plate installed over the unused power supply slot for proper cooling. Avaya recommends you use PS 1 (the left most power supply slot when viewed from the front) in a single power supply installation.

**Before you begin**

Verify that the fan trays and power supply are compatible—ensure that the airflow direction for all fans and power supplies match.

## Procedure

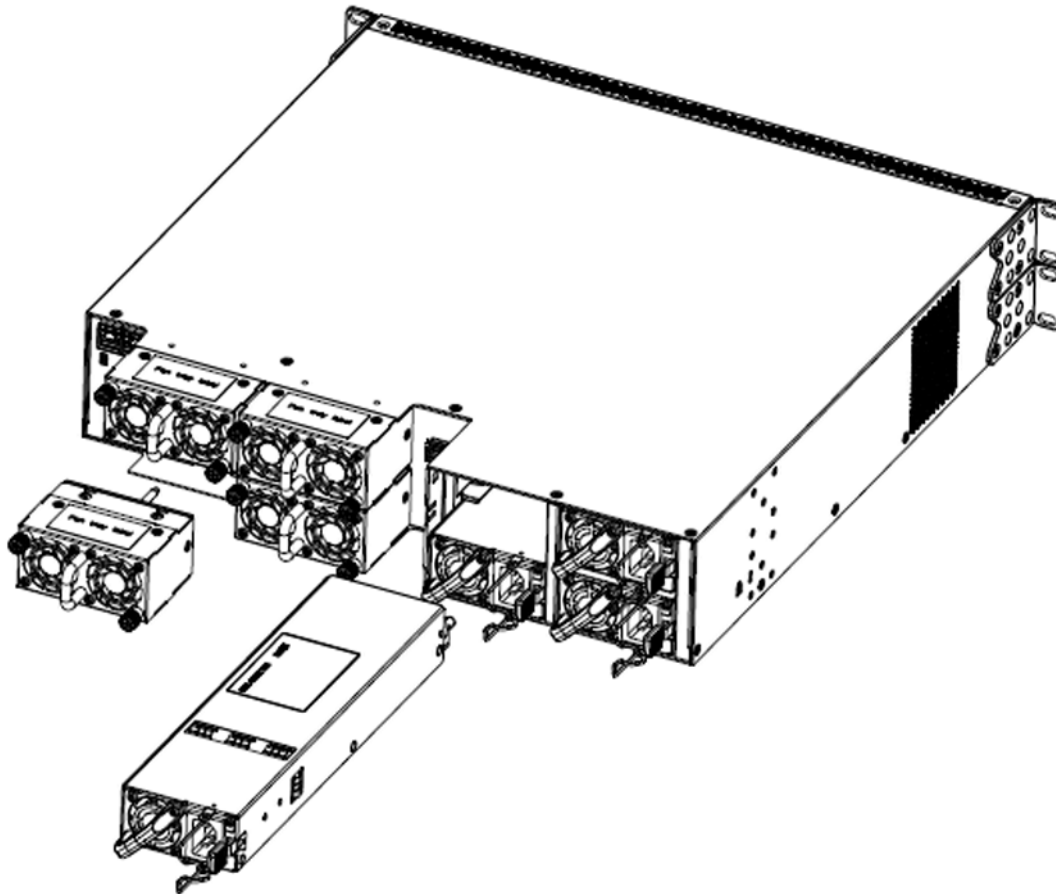
1. Insert each fan tray into a rear fan tray slot.
2. Verify that each fan tray is fully seated in the slot and secure each fan tray with two thumb screws.
3. Insert each power supply into a rear power supply slot.

If a blanking plate covers the required power-supply slot, remove the plate before inserting the power supply.

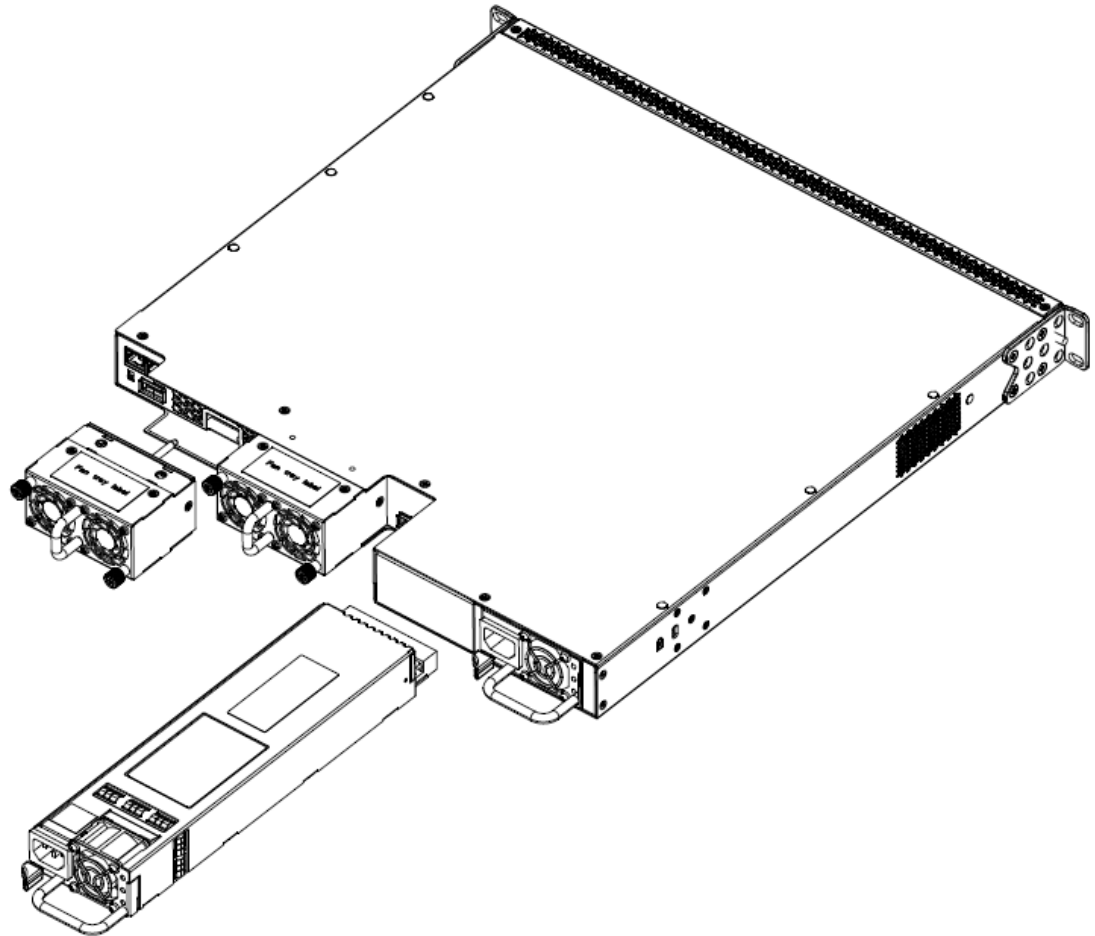
4. Verify that each power supply is fully seated in the slot and securely clipped in place.

## Example

The following figures show how to properly insert the cooling fan trays and power supplies into your switch.



**Figure 7: Installing the fan trays and power supplies in ERS 59100GTS and ERS 59100GTS-PWR+**



**Figure 8: Installing the fan trays and power supplies in ERS 5900 Series**

### **Next steps**

After you install the two fan trays and at least one power supply, you can install and connect power to the switch.

---

## **Connecting AC power**

Perform the following procedure to connect an AC power source to the switch.

### **Before you begin**

To connect AC power to the switch an appropriate AC power cord is required. Ensure the switch power supply supports AC power input.

 **Danger:**

Use only power cords with a grounding path. Without a proper ground, a person who touches the switch is in danger of receiving an electrical shock. A switch without a proper grounding path can result in excessive emissions.

**Procedure**

1. Plug the female end of the AC power cord into the back of the switch power supply.

 **Important:**

The switch will power on immediately when it is connected to a suitable AC power source. The switch does not have a power switch.

2. Plug the male end of the AC power cord into a suitable AC power outlet.

 **Caution:**

Ensure you only use an appropriately rated AC power cord. Do not use an extension cord.

 **Warning:**

The only way to turn off the switch is to disconnect the power. Always connect the AC power cord in a location that can be reached quickly and safely in case of an emergency.

# Chapter 5: Switch installation

This chapter provides information and procedures to install and configure the switch.

## Installing the switch

The switch can be installed on an equipment rack or using optional four-post rack-mount brackets.

See the following sections for installing the switch depending on the switch model:

Switch model	Procedure	Description
ERS 5928GTS, ERS 5952GTS-PWR+, ERS 5928GTS-PWR+, ERS 5928GTS-uPWR	<a href="#">Installing the ERS 5900 switch in an equipment rack</a> on page 32	Describes how to install the switch using the supplied brackets on a two-post equipment rack.  The brackets secure the chassis and prevent it from sliding around during vibration or when inserting or extracting transceivers.
	<a href="#">Installing the switch using optional four-post rack mount brackets</a> on page 38	Describes how to install the switch using optional four-post rack mount brackets and then, slide the switch.  The brackets secure the chassis and prevent it from sliding around during vibration or when inserting or extracting transceivers.
ERS 59100GTS, ERS 59100GTS-PWR+	<a href="#">Installing ERS 59100GTS and ERS 59100GTS-PWR+ in an equipment rack</a> on page 34	Describes how to install the switch using the supplied brackets on a two-post equipment rack.  The brackets secure the chassis and prevent it from sliding around during vibration or when inserting or extracting transceivers.
	<a href="#">Installing the switch using optional four-post rack mount brackets</a> on page 38	Describes how to install the switch using optional four-post rack mount brackets and then, slide the switch.  The brackets secure the chassis and prevent it from sliding around during vibration or when inserting or extracting transceivers.

---

## Installing ERS 5900 switch in an equipment rack

### About this task

To install switches ERS 5952GTS, ERS 5928GTS, ERS 5952GTS-PWR+, ERS 5928GTS-PWR+, and ERS 5928GTS-uPWR.

### Before you begin

#### Tool requirements

- Phillips screwdriver to attach brackets to the switch and the switch to the rack

#### Rack requirements

- Space of 2.8 inches (7.1 cm) for each switch is available in an E1A or 1EC standard 19 inch (48.2 cm) equipment rack and T1A 23 inch (58.5 cm) equipment rack.
- Appropriate rack space is available to accommodate 1U switch height (44 mm).
- Rack is bolted to the floor and braced if necessary.
- Rack is grounded to the same grounding electrode used by the power service in the area. The ground path must be permanent and must not exceed 1 Ohm of resistance from the rack to the grounding electrode.

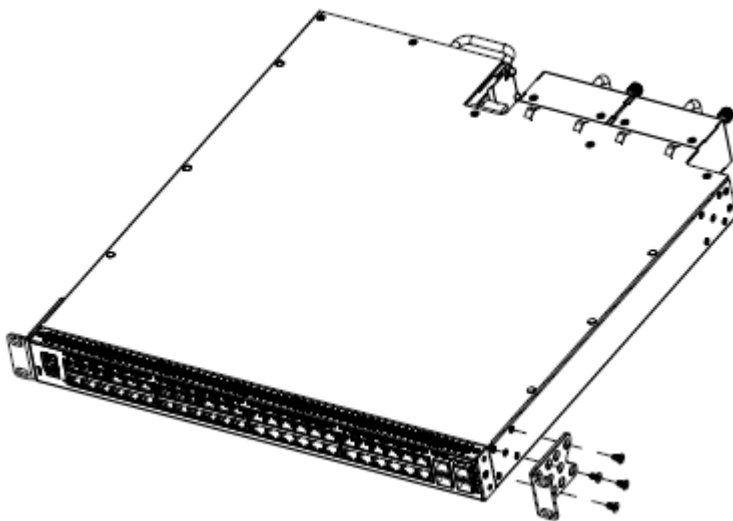
#### \* Note:

Avaya does not supply the bolts used to secure the switch to the rack. Ensure you obtain the appropriate bolts to secure the switch to your specific rack before you begin.

### Procedure

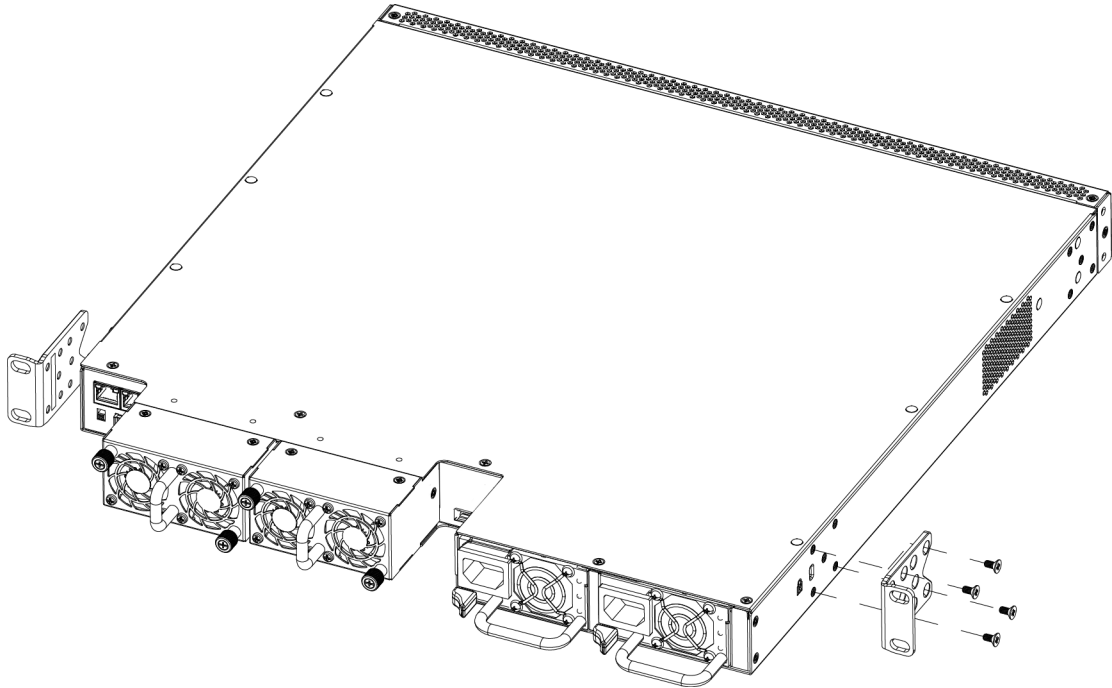
1. Ensure power is disconnected from the switch.
2. Attach a bracket to each side of the switch with the included screws.

You have different options for front and rear mounting positions. Attach the brackets in the best position for your specific equipment rack.



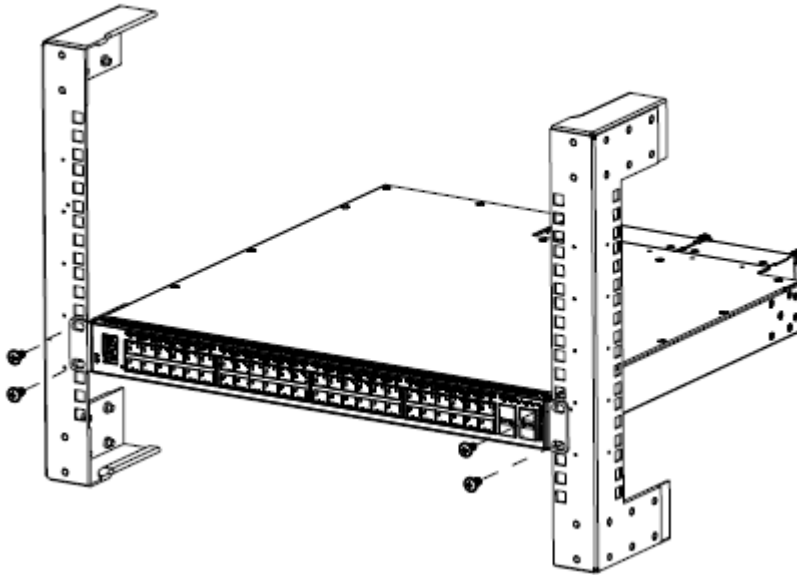
**Figure 9: Front-mounted rack bracket installation**





**Figure 10: Rear-mounted rack bracket installation**

3. Slide the switch into the rack.
4. Insert and tighten the rack mount screws.



**Figure 11: Front-mounted rack installation**

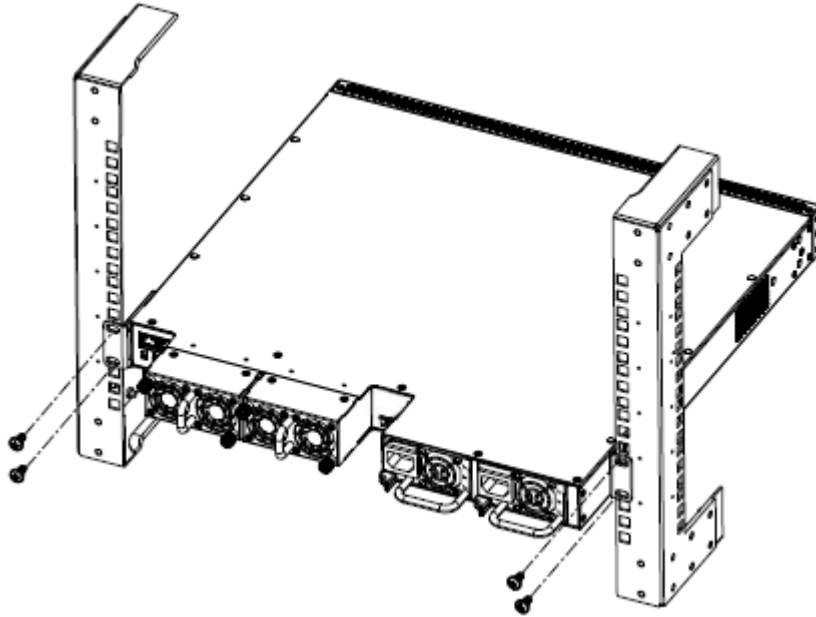


Figure 12: Rear-mounted rack bracket installation

---

## Installing ERS 59100GTS and ERS 59100GTS-PWR+ in an equipment rack

### About this task

Install ERS 59100GTS and ERS 59100GTS-PWR+ on an equipment rack. To install other switches in ERS 5900 Series, see [Installing ERS 5900 switch in an equipment rack](#) on page 32.

### Before you begin

#### Tool requirements

- Phillips screwdriver to attach brackets to the switch and the switch to the rack.

#### Rack requirements

- Space of 2.8 inches (7.1 cm) for each switch is available in an E1A or 1EC standard 19 inch (48.2 cm) equipment rack and T1A 23 inch (58.5 cm) equipment rack.
- Appropriate rack space is available to accommodate 2U switch height (88.5 mm).
- Rack is bolted to the floor and braced if necessary.
- Rack is grounded to the same grounding electrode used by the power service in the area. The ground path must be permanent and must not exceed 1 Ohm of resistance from the rack to the grounding electrode.

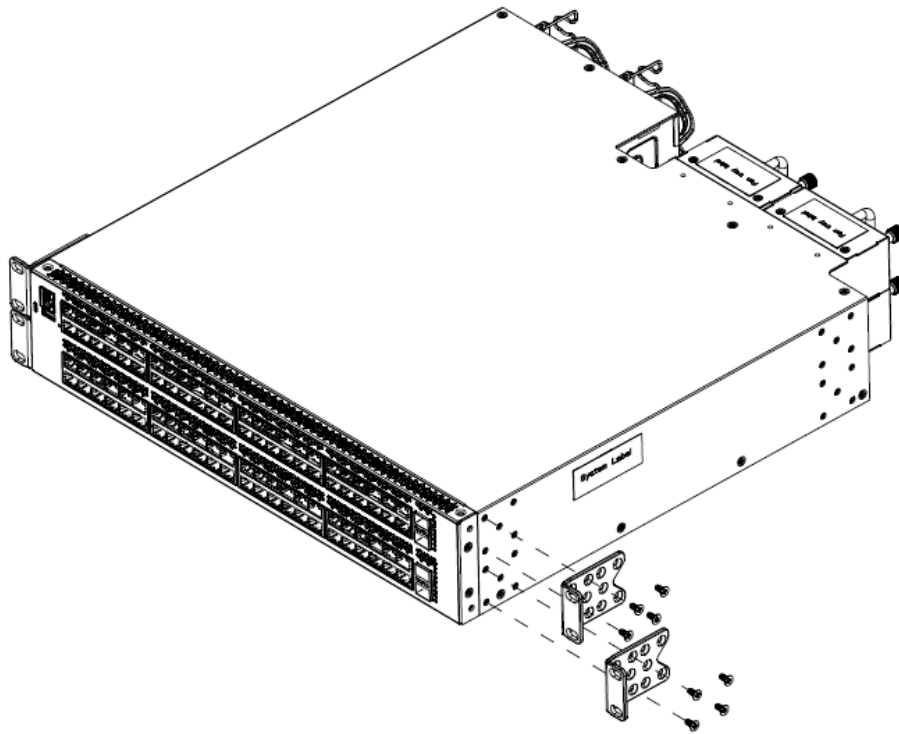
**\* Note:**

Avaya does not supply the bolts used to secure the switch to the rack. Ensure you obtain the appropriate bolts to secure the switch to your specific rack before you begin.

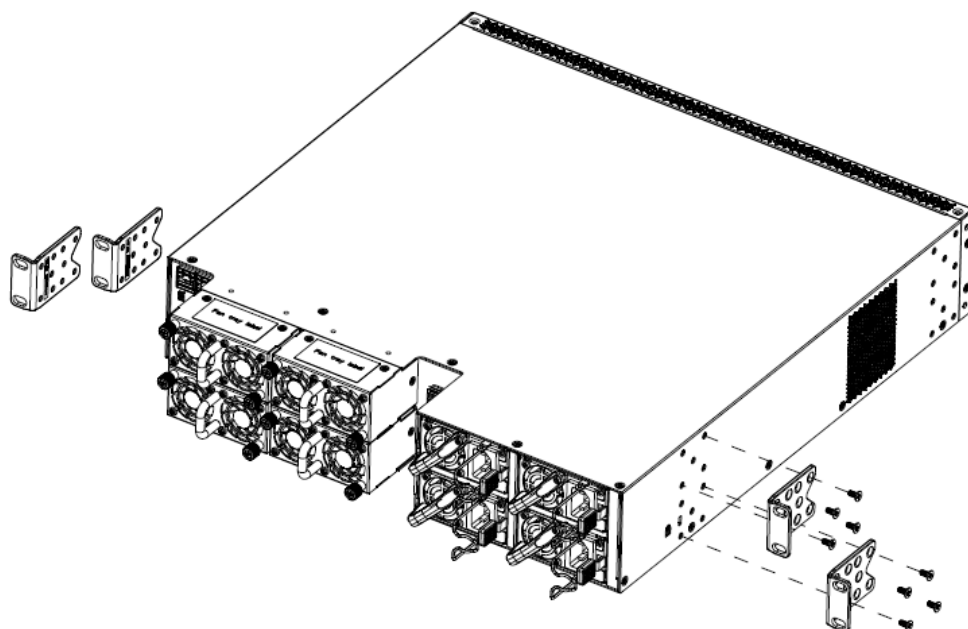
**Procedure**

1. Ensure power is disconnected from the switch.
2. Attach a bracket to each side of the switch with the included screws.

You have different options for front and rear mounting positions. Attach the brackets in the best position for your specific equipment rack.

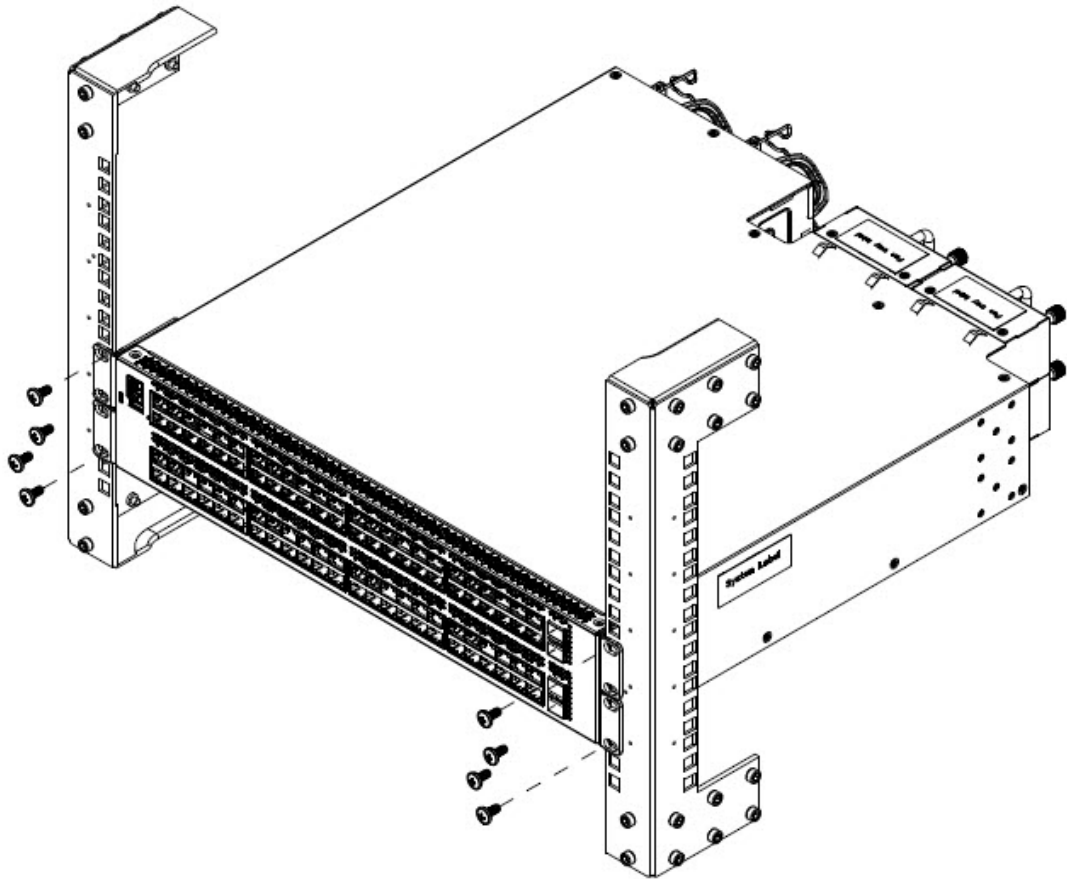


**Figure 13: Front-mounted rack bracket installation**

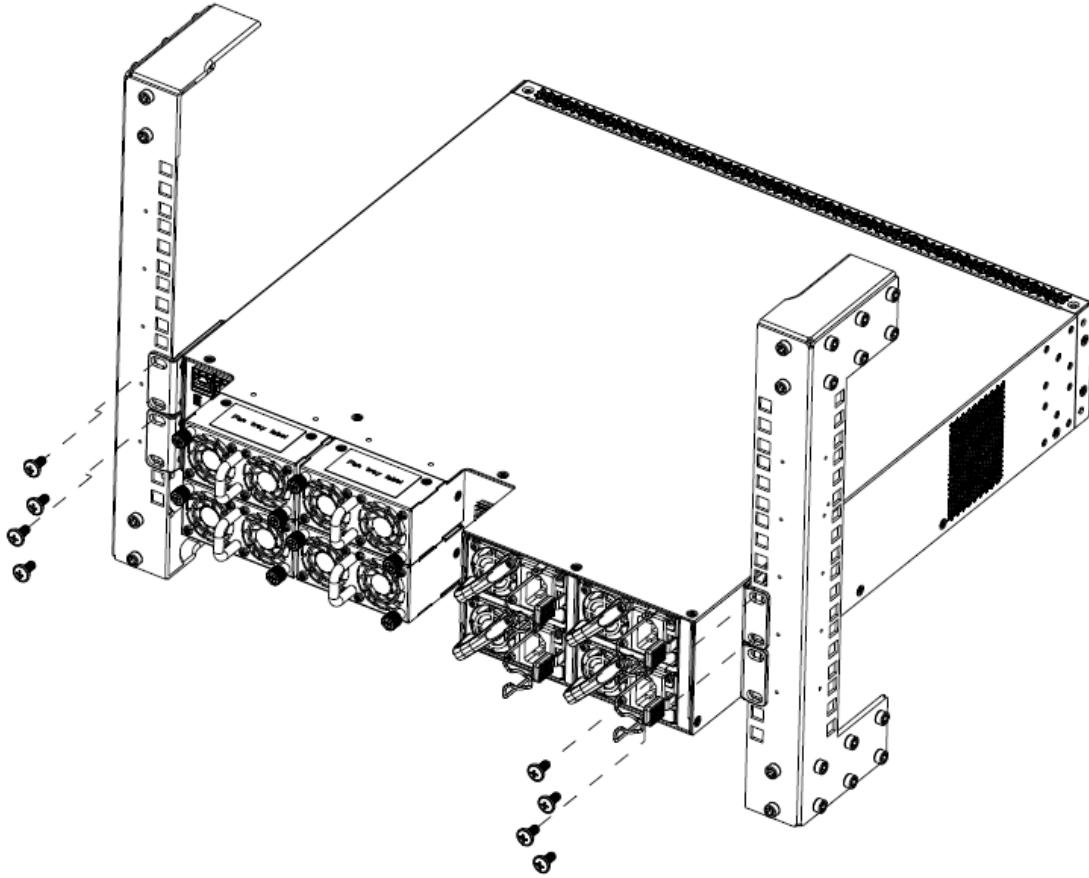


**Figure 14: Rear-mounted rack bracket installation**

3. Slide the switch into the rack.



**Figure 15: Front-mounted rack installation**



**Figure 16: Rear-mounted rack installation**

4. Insert and tighten the rack mount screws.
5. Verify that the switch is securely fastened to the rack.

You can proceed with the installation by connecting power and network connections to the switch.

---

## Installing the switch using optional four-post rack-mount brackets

Perform this procedure to assemble and install the four-post rack-mount bracket kit.

### Before you begin

ERS 5900 Series four-post server rack-mount kit — AL5911001-E6

### Tool requirements

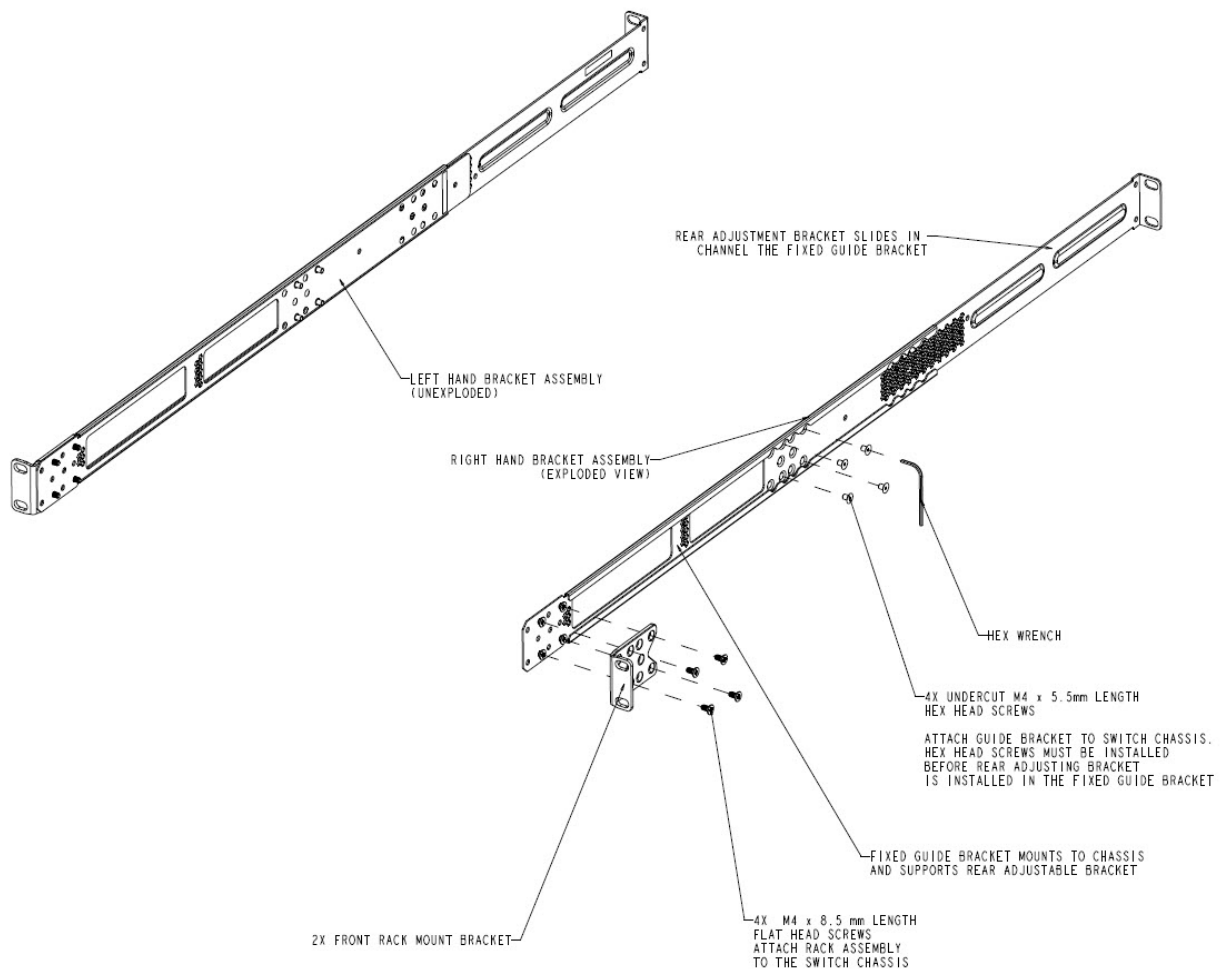
- Phillips screwdriver to attach brackets to the switch and the switch to the rack.

- Hex wrench to assemble and attach the optional four-post rack-mount brackets.

### Rack requirements

- Space of 2.8 inches (7.1 centimeters) for each switch in an E1A or 1EC standard 19 inch (48.2 centimeter) equipment rack and T1A 23 inch (58.5 centimeter) equipment rack.
- Appropriate rack space to accommodate 1U or 2U switch height.
- Four-post rack bolted to floor and braced if necessary.
- Four post-rack must be grounded to the same grounding electrode used by the power service in the area. The ground path must be permanent and must not exceed 1 ohm of resistance from the rack to the grounding electrode.

Verify that you have all the screws and brackets to assemble and install the four-post rack mount kit.

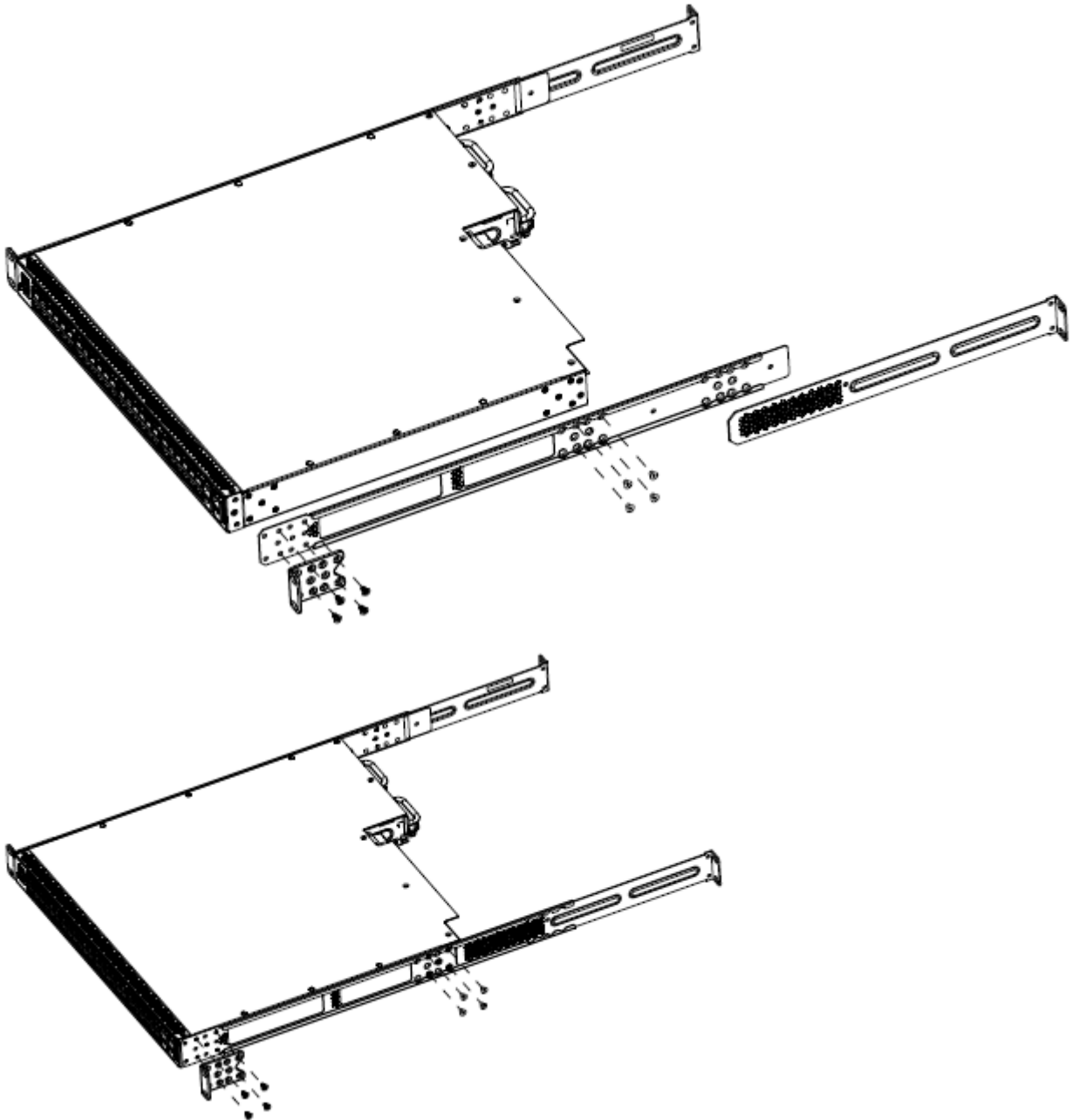


**Figure 17: Four-post rack-mount kit assembly**

### Procedure

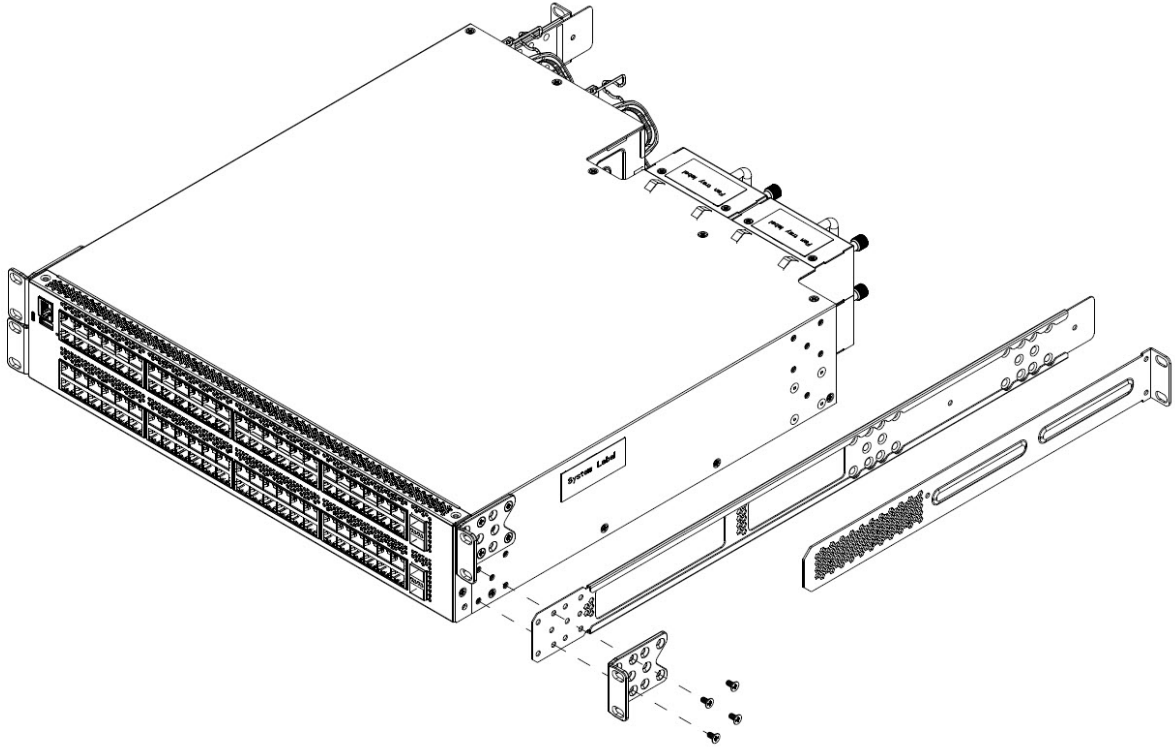
1. Attach a front bracket to each guide bracket with four 8.5 mm length flat head machine screws.

2. Attach the guide brackets to the switch chassis.



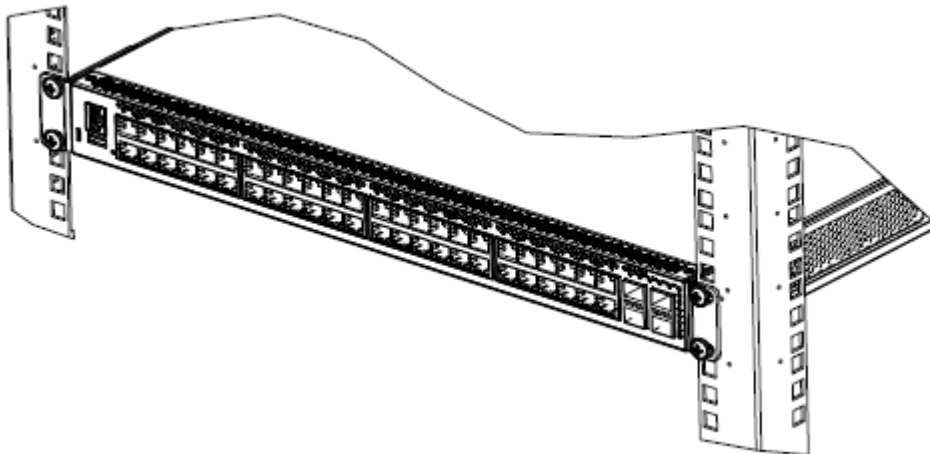
**Figure 18: Attaching guide brackets to ERS 5900 switch**





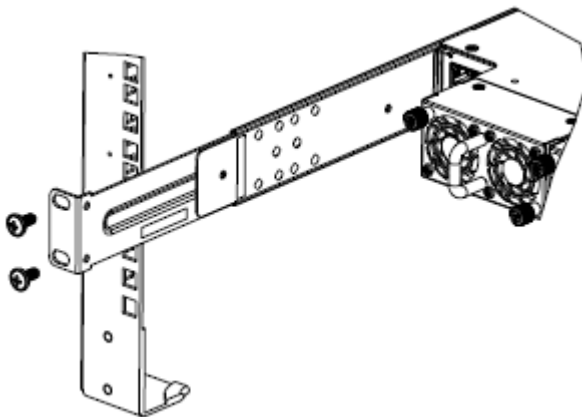
**Figure 19: Attaching guide brackets to ERS 59100 switch**

- a. Use four M4 x 5.5 mm undercut flat-head hex machine screws to attach the rear of each guide bracket to the switch chassis.
  - b. Verify that the rear screws sit flush in the guide brackets.
  - c. Test fit the rear mounting brackets in the guide brackets and verify that the rear brackets can slide in the channels. Remove the rear brackets.
3. Install the switch into the equipment rack, temporarily using only the front rack mounts and screws.



**Figure 20: Install ERS 5900 switch in rack using front rack mounts**

4. Attach the rear mounting brackets and secure the switch to the rear rack posts.
  - a. Slide a rear mounting bracket into each guide bracket channel until flush with the rear rack posts.
  - b. Secure the rear mounting brackets to the switch chassis with the pan-head screws.



**Figure 21: Attach ERS 5900 switch rear mounting brackets**

You can proceed with the installation by connecting power and network connections to the switch.

---

## Single and multiple switch arrangements

This module describes standalone and stacked arrangements.

You can stack any of the switches in the ERS 5900 Series. You can connect up to eight switch devices that are in one Rack Unit (RU) height in a stack to provide uninterrupted connectivity for up to 384 ports.

For ERS 5900 Series, the stacking bandwidth is 42 Gbps per port and 84 Gbps per switch.

**\* Note:**

The height of ERS 59100GTS and ERS 59100GTS-PWR+ are 2 RUs. You can connect up to four switch devices in a stack.

---

## Standalone arrangement

Any one switch can operate in a standalone configuration. You can add more switches as your traffic increases.

---

## Stack arrangement

You connect the switches in the stack by the stack connectors. You designate one unit as the base unit by setting a switch on the back panel.

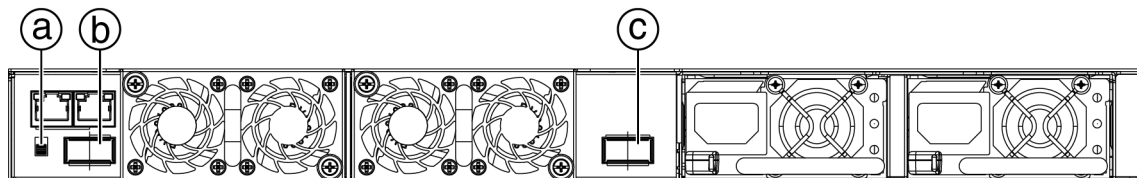
The stack connector is a component of the back panel and consists of the Base Unit Select switch, Cascade Down connector, and Cascade Up connector.

The Cascade Down connector connects this switch to the next unit in the stack through a cascade cable. A connection from this connector must be attached to the Cascade Up connector of the next switch in the stack. A return cable from another Cascade Down connector to this unit's Cascade Up connector completes the stack connection.

**! Important:**

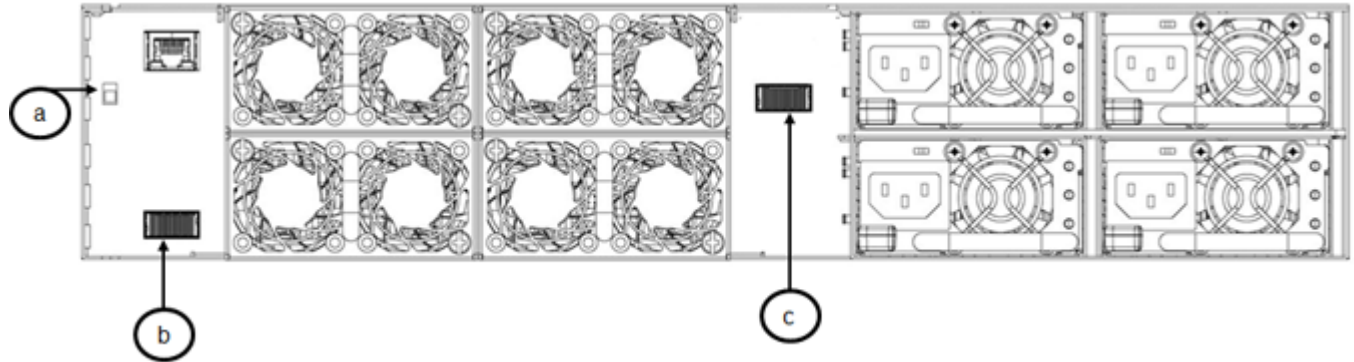
To create a stack connection, order the appropriate cascade cables to ensure fail-safe stacking. Order stacking cables of the correct length for a stack of three or more units. You require one long cable (stack return cable) to complete the loop in a stack from the bottom unit to the top unit. See [Cascade down](#) on page 45 and [Cascade up](#) on page 47.

The Cascade Up connector provides an attachment point for accepting a cascade cable connection from another unit in the stack. A return cable from the Cascade Down connector to the Cascade Up connector on the adjacent unit completes the stack connection.



- a. Base Unit switch
- b. Cascade Down connector
- c. Cascade Up connector

**Figure 22: ERS 5900 stack connectors**



- a. Base Unit switch
- b. Cascade Down connector
- c. Cascade Up connector

**Figure 23: ERS 59100 stack connectors**

---

## Understanding stack types

This section describes the different stack types.

Due to stack parameters being associated with the base unit, the physical stack order depends on the base unit position and whether the stack is configured cascade up (stack up) or cascade down (stack down). This designation depends on the stack cabling arrangement.

The Unit Select switch is used to designate a switch in the stack as a base or non-base unit. Sliding the switch down designates that switch as the base unit. Only one switch in a stack can have the Unit Select switch in the base unit position. All other switches in the stack must have the Unit Select switch in the up position which designates them as non-base units.

During the initial installation of the stack, the software automatically determines the physical order of all units in the stack according to the position of the base unit within the stack. Thereafter, the individual units maintain their original unit numbering, even if the position of one or more units in the stack is changed.

For example, when the stack is initially powered, the base unit becomes unit 1 and the unit that the base unit connects to (via the Cascade Down cable) becomes unit 2 (and the next unit is unit 3 and so on), until the maximum stack configuration (up to eight units for a ERS 5900 Series stack and up to four units for a ERS 59100 stack) is reached. If the base unit is changed to another unit in the stack, the new base unit keeps its original unit number in the stack.

When a switch participates in a stack configuration, a stack MAC address is automatically assigned during stack initialization. The stack MAC address is the base unit MAC address plus 1. If another

unit in the stack is assigned as the base unit, the new stack MAC address is the MAC address of the new base unit plus 1. The original stack IP address still applies to the new base unit.

If an assigned base unit fails, the next unit in the stack order automatically becomes the new temporary base unit. This change is indicated by the Base LED on the temporary base unit LED display panel moving to a steady amber state.

This automatic failover is a temporary safeguard only. If the stack configuration loses power, the temporary base unit will not power up as the base unit when power is restored. Also, if the original unit rejoins the stack, it will not resume base unit status. For this reason, always assign the temporary base unit as the base unit until the failed unit is repaired or replaced.

**!** **Important:**

If the temporary base unit is not assigned as the new base unit, and the temporary base unit fails, the next unit in the stack order becomes the temporary base unit. This process will continue after successive failures until only two units are left in the stack.

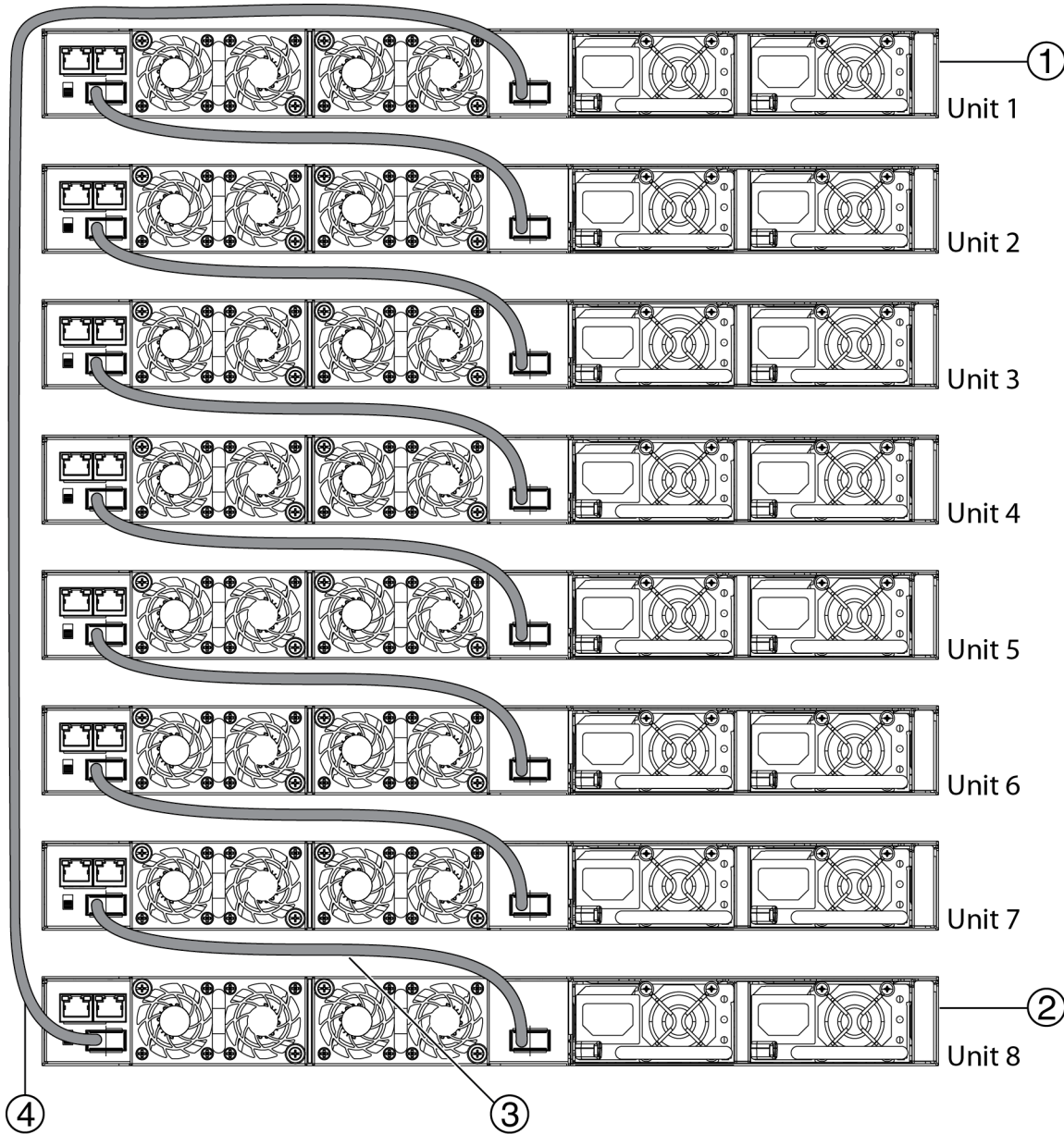
Regardless of stack configuration, the following applies:

- When power is applied to the stack the base unit initializes, typically within 60 seconds, and the entire stack powers up as a single logical unit.
- A RS-232 communications cable can be attached to the console port of any switch in the stack to establish a console connection.
- A software upgrade can be performed on the stack from any switch using the console interface, a Telnet session, the Enterprise Device Manager interface, or any SNMP-based management software.
- The stack can be managed using a Telnet session, Enterprise Device Manager interface, or any SNMP-based management software through any stack switch port.

---

## Cascade down

The system automatically numbers the physical units based on the designated base unit (Unit 1). In a cascade down configuration, the base unit is physically located as the top unit in the stack. The cable connected to the Cascade Down connector of the base unit terminates in the Cascade Up connector on the next unit in the stack which is physically located below the base unit. This next unit is designated Unit 2. The stack is wired downward through the units and the system continues to number in this manner throughout the stack. In this configuration, the base unit discovers the stack in a cascade down (stack down) direction. The following illustration shows a cascade down (stack down) configuration for ERS 5900 switch series. The ERS 59100 switch can be connected similarly.



- 1 = Base unit
- 2 = Last unit
- 3 = 0.5m Cascade/Stack cable
- 4 = 1.0m Cascade/Stack cable (Return cable)

**Figure 24: ERS 5900 cascade down configuration**

**\* Note:**

Return cable length may vary depending on unit spacing. Ensure you order the proper length return cable to provide adequate strain relief.

**!** Important:

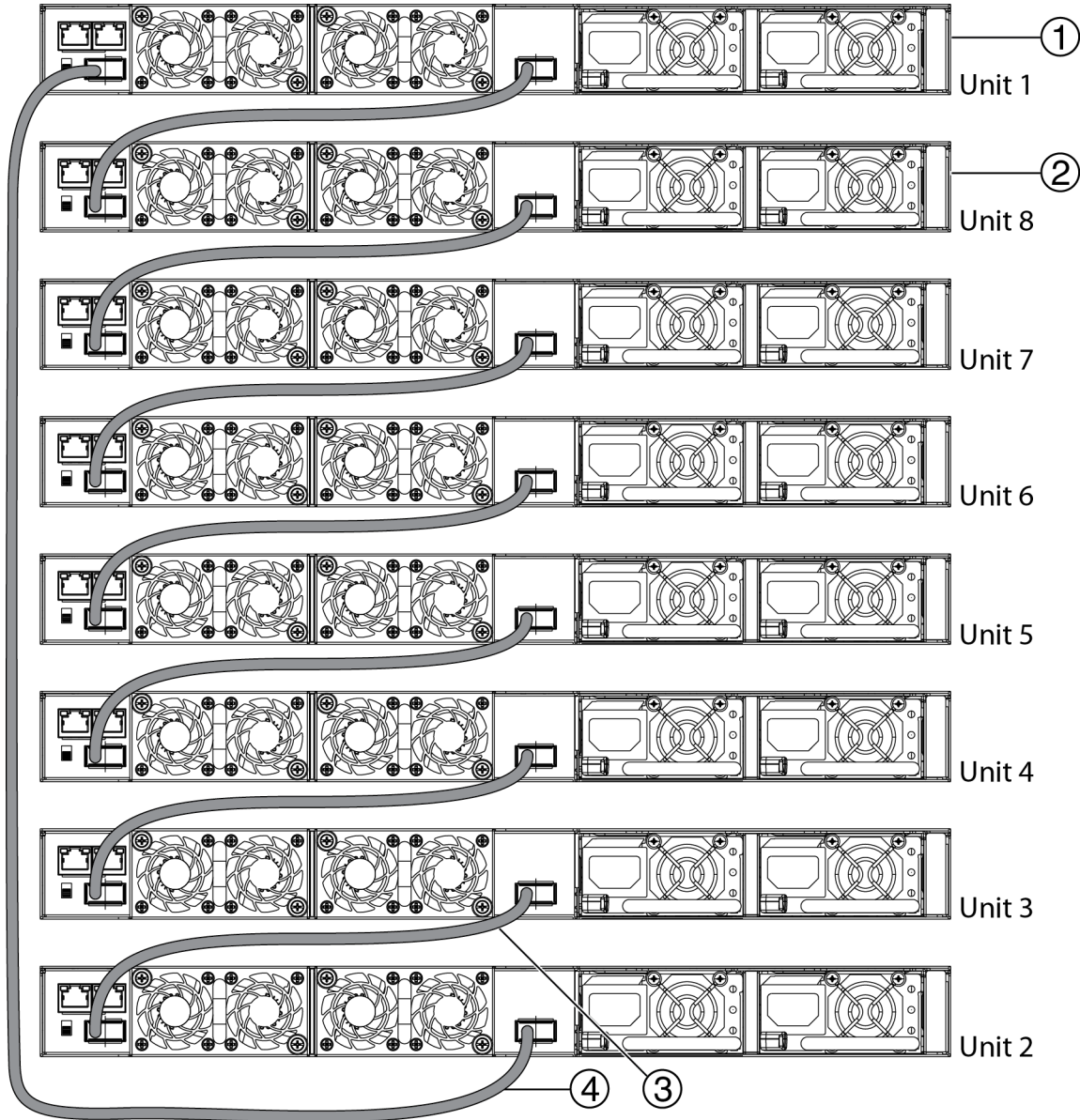
Since many network management software packages assume a cascade down (stack down) configuration, Avaya recommends the usage of this configuration.

For stack installation procedures, see [Stack configuration](#) on page 50.

---

## Cascade up

In a cascade up (stack up) configuration, the base unit is physically located as the top unit in the stack. The cable connected to the Cascade Down connector of the base unit terminates in the Cascade Up connector physically located at the bottom of the stack. This next unit is designated Unit 2. The stack is wired upward through the units and the system continues to number in this manner throughout the stack. In this configuration, the base unit discovers the stack in a cascade up (stack up) direction. The following illustration shows a cascade up (stack up) configuration.



- 1 = Base unit
- 2 = Last unit
- 3 = 0.5m Cascade/Stack cable
- 4 = 1.0m Cascade/Stack cable (Return cable)

**Figure 25: Cascade up configuration**

**\* Note:**

Return cable length may vary depending on unit spacing. Ensure you order the proper length return cable to provide adequate strain relief.

For stack installation procedures, see [Stack configuration](#) on page 50.



---

## Redundant cascade stacking

The 5900 Series switches allow a stack of up to eight units in a 5900 Series stack. If any single unit fails or if a cable is accidentally disconnected, other units in the stack remain operational without interruption.

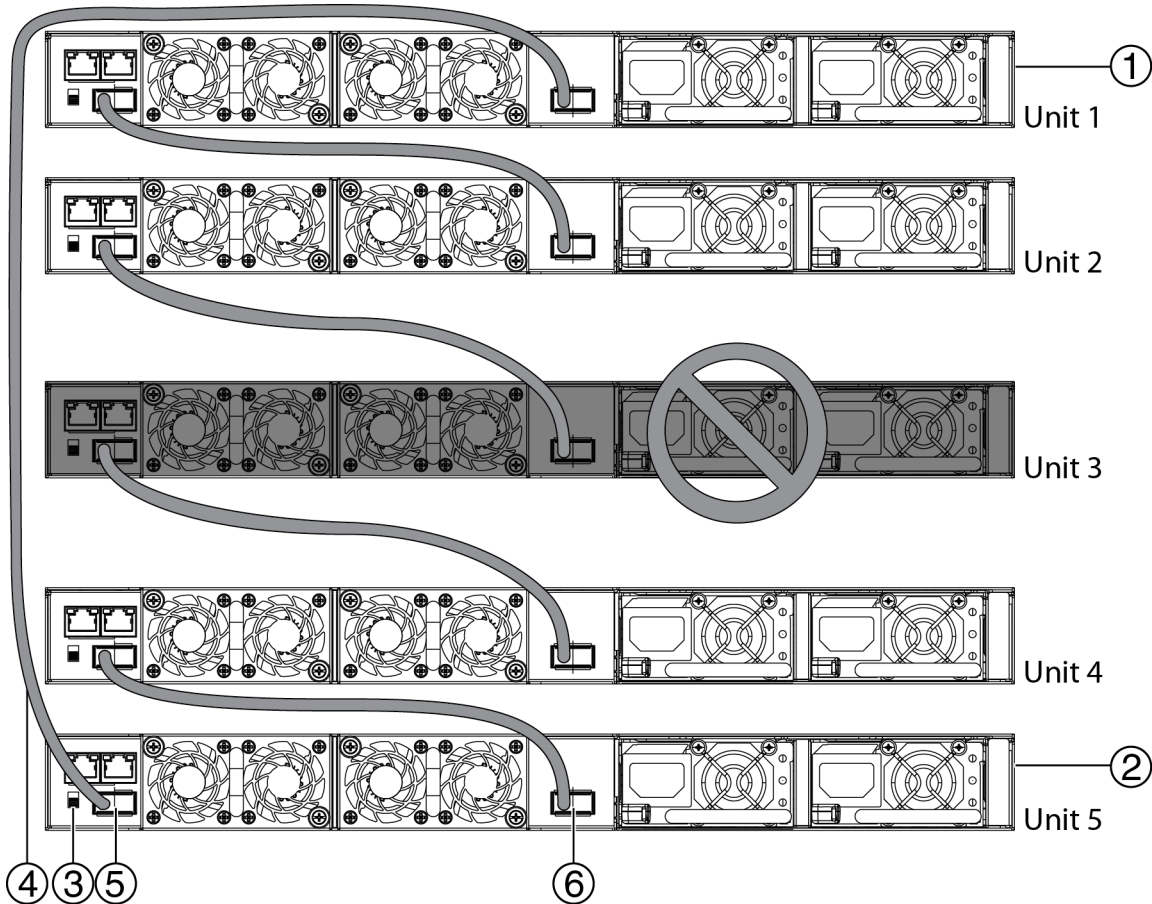
In addition to increasing bandwidth, the software uses the cables to provide two paths between units. If one path breaks the data travels over the remaining path with half the normal inter-switch bandwidth.

The following diagram shows an example of how a stack configuration reacts to a failed connection in the stack configuration. In the illustrated example, the following occurs:

- Unit 3 becomes non-operational due to a unit failure, cable disconnection, or a loss of power.
- Units 2 and 4, directly upstream and downstream from Unit 3, sense the loss of link signals from unit 3. The software causes all the data to traverse the remaining path.
- The Cascade Down LED for Unit 2 and the Cascade Up LED for Unit 4 turn amber to indicate an error has been detected.
- The remaining stack units continue to be connected.

There are four internal ports for two Cascade links. Internal ports 1 and 2 are associated with Cascade-Down link and internal ports 3 and 4 are associated with Cascade-Up link. When viewing the event log after a stack port goes down, use the following information to help determine the problem:

- Message Stack port 1 DOWN or Stack port 2 DOWN means Cascade-Down link is down.
- Message Stack port 1 UP or Stack port 2 UP means Cascade-Down link is up.
- Message Stack port 3 DOWN or Stack port 4 DOWN means Cascade-Up link is down.
- Message Stack port 3 UP or Stack port 4 UP means Cascade-Up link is up.



**Figure 26: Redundant stack configuration**

For stack installation procedures, see [Stack configuration](#) on page 50.

---

## Stack configuration

### About this task

This section describes the procedures to configure a stack.

**!** **Important:**

You can change base unit switches with switches on (hot), but changes do not take effect until switches are rebooted.

### Selecting a base unit

#### About this task

This procedure describes the steps to select a base unit.

#### Procedure

1. Determine which unit will be the base unit.

2. Locate the Base Unit switch on the rear panel.
3. Slide the switch to the down position to designate it as the base unit.

## Setting non-base units

### About this task

The following procedure describes the steps to set the units as non-base switches.

### Procedure

Set the Base Unit switches to the up position to designate them as non-base units.

---

## Cabling a stack

This procedure describes the steps to cable a stack.

### Procedure

1. Choose a Cascade up or Cascade down configuration.
2. Connect cables as appropriate for the chosen configuration.
3. Select the base unit.
4. Connect the console cable.
5. Connect the AC power cord.

If you assign the base unit and non-base units with the switches powered up, you must reset the switches for the assignments to be applied.

---

## Identifying cables to use with the Ethernet Routing Switch

The following table lists the required cables for a switch and cable specifications.

**Table 9: Switch cabling requirements**

Required cable	Description
10/100/1GBase-T Ports	The interconnect cabling must conform to the Cat5e, Cat6, or Cat6e specification of the Commercial Building Telecommunications Cabling Standard, ANSI/TIA/EIA 568-B fitted with an RJ-45 Module Jack.
Console Port	Serial cable with a DB-9 female connector on both ends. The maximum length for the console port cable is 25 feet (8.3 meters).
Shared SFP Transceiver Ports	Varies with the installed SFP Transceiver. Refer to the documentation that was shipped with the SFP Transceiver for specifications.
USB Ports	USB 2.1 compliant cable with a USB Type A connector on both ends.

**! Important:**

In Autonegotiation mode, the switches automatically provide the proper MDI/MDI-X connection on the RJ-45 ports; thereby eliminating the need for crossover cables. When Autonegotiation is disabled on 10/100 ports, they are configured as an MDI-X connection.

---

## Connecting a transceiver to the switch or switch stack

The following sections describe small form factor pluggable (SFP) transceivers in the Ethernet Routing Switch 5900 Series. For installation and removal procedures, see *Installing Transceivers and Optical Components on Avaya Ethernet Routing Switch 4900 and 5900 Series*, NN47211-302.

---

## Installing transceivers

### About this task

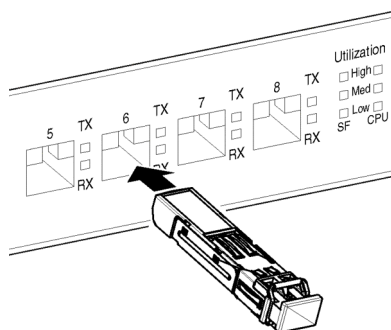
This procedure describes the steps used to install transceivers.

### Procedure

1. Remove the transceiver from the protective packaging.
2. Verify that the transceiver is the correct model for the network configuration.
3. Grasp the transceiver between the thumb and forefinger.
4. Insert the transceiver into the proper module on the switch. Apply a light pressure to the transceiver until it clicks and locks into position in the module.
5. Remove the dust cover from the transceiver optical bores.

### Job aid

The following graphic shows an SFP transceiver.



**Figure 27: SFP transceiver**

## Supported optical devices

Use optical devices to achieve high-bit-rate communications and long transmission distances. The following section describes the supported optical devices on the switches.

### ! Important:

Avaya recommends that you use Avaya branded SFP and SFP+ transceivers as they undergo extensive qualification and testing. Avaya is not responsible for any problems that arise from using non-Avaya branded SFP and SFP+ transceivers.

### Small form-factor pluggable (SFP) transceivers

SFPs are hot-swappable input and output enhancement components designed to allow gigabit Ethernet ports to link with other gigabit Ethernet ports over various media types.

You can use various SFP (1 Gbps) and SFP+ (10 Gbps) to attain different line rates and reaches. The following table describes the SFPs including the reach provided by various SFPs.

This table is informational only—not all Avaya Ethernet switching and routing products support all the SFPs listed here.

For more information about SFP and SFP+ transceivers, including technical specifications and installation instructions, see *Installing Transceivers and Optical Components on Avaya Ethernet Routing Switch 4900 and 5900 Series*, NN47211-302.

### ! Important:

The attainable cable length can vary depending on the quality of the fiber-optic cable used.

**Table 10: SFP transceivers**

Model	Description	Part number
<b>! Important:</b> Avaya supports SFP transceivers with the following part numbers: AA1419013–E5, AA1419014–E5, AA1419015–E5, and AA1419025–E5 to AA1419040–E5. However, Avaya strongly recommends using the newer DDI versions of these SFP transceivers.		
1000BASE-T SFP	gigabit Ethernet, RJ-45 connector	AA1419043–E6
1000BASE-SX SFP	850 nm LC connector	AA1419013–E5** This transceiver has reached end-of-sale (EOS). For more information about EOS transceivers, and recommended replacements for your product, see <a href="#">Locating end of sale notices</a> on page 56.
1000BASE-SX SFP	850 nm MT-RJ connector	AA1419014–E5** This transceiver has reached end-of-sale (EOS). For more information about EOS transceivers, and recommended

*Table continues...*

Model	Description	Part number
		replacements for your product, see <a href="#">Locating end of sale notices</a> on page 56.
1000BASE-LX SFP	1310 nm LC connector	AA1419015–E5** This transceiver has reached end-of-sale (EOS). For more information about EOS transceivers, and recommended replacements for your product, see <a href="#">Locating end of sale notices</a> on page 56.
1000BASE-XD CWDM SFP	From 1470 nm to 1610 nm LC connector, up to 40 km	AA1419025–E5 to AA1419032–E5** These transceivers have reached end-of-sale (EOS). For more information about EOS transceivers, and recommended replacements for your product, see <a href="#">Locating end of sale notices</a> on page 56.
1000BASE-ZX CWDM SFP	From 1470 nm to 1610 nm LC connector, up to 70 km	AA1419033–E5 to AA1419040–E5** These transceivers have reached end-of-sale (EOS). For more information about EOS transceivers, and recommended replacements for your product, see <a href="#">Locating end of sale notices</a> on page 56.
1000BASE-SX DDI SFP	850 nm, gigabit Ethernet, duplex LC connector	AA1419048–E6
1000BASE-LX DDI SFP	1310 nm, gigabit Ethernet, duplex LC connector	AA1419049–E6
1000BASE-XD DDI SFP	1310 nm, gigabit Ethernet, duplex LC connector	AA1419050–E6* * This transceiver has reached end-of-sale (EOS). For more information about EOS transceivers, and recommended replacements for your product, see <a href="#">Locating end of sale notices</a> on page 56.
1000BASE-XD DDI SFP	1550 nm, gigabit Ethernet, duplex LC connector	AA1419051–E6* * This transceiver has reached end-of-sale (EOS). For more information about EOS transceivers, and recommended replacements for your product,

*Table continues...*

Model	Description	Part number
		see <a href="#">Locating end of sale notices</a> on page 56.
1000BASE-ZX DDI SFP	1550 nm, gigabit Ethernet, duplex LC connector	AA1419052–E6* * This transceiver has reached end-of-sale (EOS). For more information about EOS transceivers, and recommended replacements for your product, see <a href="#">Locating end of sale notices</a> on page 56.
1000BASE-XD DDI SFP	gigabit Ethernet, duplex LC connector	AA1419053–E6 to AA1419060–E6** These transceivers have reached end-of-sale (EOS). For more information about EOS transceivers, and recommended replacements for your product, see <a href="#">Locating end of sale notices</a> on page 56.
1000BASE–ZX DDI CWDM 70 km SFP	gigabit Ethernet, duplex LC connector	AA1419061–E6 to AA1419068–E6** These transceivers have reached end-of-sale (EOS). For more information about EOS transceivers, and recommended replacements for your product, see <a href="#">Locating end of sale notices</a> on page 56.  <b>!</b> <b>Important:</b> AA1419065–E6 remains available for purchase.
1000BASE-BX10 DDI SFP	1310 nm (tx) and 1490 nm (rx) gigabit Ethernet, single-fiber LC connector	AA1419069–E6 (10 km at 1310 nm ) and mating pair AA1419070–E6 (10 km at 1490 nm)
1000BASE-EX DDI SFP	1550 nm, gigabit Ethernet, duplex LC connector	AA1419071–E6** This transceiver has reached end-of-sale (EOS). For more information about EOS transceivers, and recommended replacements for your product, see <a href="#">Locating end of sale notices</a> on page 56.

### Small form-factor pluggable plus (SFP+) transceivers

SFP+ transceivers are hot-swappable input and output enhancement components that allow 10 gigabit connections. All Avaya SFP+ transceivers use Lucent connectors (LC) to provide precision keying and low interface losses.

The following table lists and describes the Avaya SFP+ models.

**Table 11: Supported SFP+ transceivers and cables**

Model	Description	Part number
10GBASE-SR/SW SFP+	400 m, 850 nm MMF	AA1403015–E6
10GBASE-LRM SFP+	220 m, 1260 to 1355 nm; 1310 nm nominal MMF	AA1403017–E6
10GBASE-LR/LW SFP+	10 km, 1310 nm SMF	AA1403011–E6
10GBASE-ER/EW SFP+	40 km, 1550 nm SMF	AA1403013–E6
10GBASE-CX SFP+ 2-pair twinaxial copper cable that plugs into the SFP+ socket and connects two 10-gigabit ports	SFP+ DAC 10 meter	AA1403018–E6
10GBASE-CX SFP+ 2-pair twinaxial copper cable that plugs into the SFP+ socket and connects two 10-gigabit ports	SFP+ DAC 3 meter	AA1403019–E6
10GBASE-CX SFP+ 2-pair twinaxial copper cable that plugs into the SFP+ socket and connects two 10-gigabit ports	SFP+ DAC 5 meter	AA1403020–E6
10GBASE-ZR/ZW SFP+	70 km, 1550 nm SMF	AA1403016–E6
10GBASE CWDM DDI SFP+ (40 km)	40 km, 1471 to 1611 nm	AA1403153–E6 to AA1403160–E6
10GBASE CWDM DDI SFP+ (70 km)	70 km, 1471 to 1611 nm	AA1403161–E6 to AA1403168–E6
10GBASE-BX10 SFP+	10 km	AA1403169–E6 and AA1403170–E6

### Optical power considerations

When you connect the device to collocated equipment, ensure that enough optical attenuation exists to avoid overloading the receivers of each device. You must consider the minimum attenuation requirement based on the specifications of third-party equipment. For more information about minimum insertion losses for Avaya optical products, see *Installing Transceivers and Optical Components on Avaya Ethernet Routing Switch 4900 and 5900 Series*, NN47211-302.

### Locating end of sale notices

Use the following procedure to locate the most up-to-date information on end of sale notices and replacement recommendations for transceivers and optical components.

#### Procedure

1. Go to the Avaya Support website at <http://support.avaya.com/>.
2. Select **Support by Product > Documents**.



3. Enter the product name, and a release.
4. Select Product Lifecycle Notices.
5. Click **Enter**.
6. Select the End of Sale notice to view the information.

---

## Checking status LEDs to verify switch installation

Perform this procedure to verify the hardware installation and operation of the unit.

The eight status LEDs on the front of the unit indicate the installation and operational status of the hardware.

### Before you begin

Perform the following tasks before checking the status LEDs.

- Install the fan trays and power supplies.
- Install the switch in an equipment rack or on a shelf.
- Connect power to the switch.

### Procedure

1. Locate the status LEDs on the front of the unit; see the following figure.

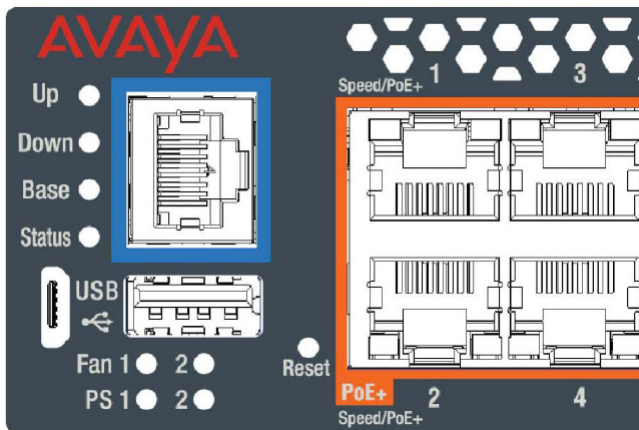
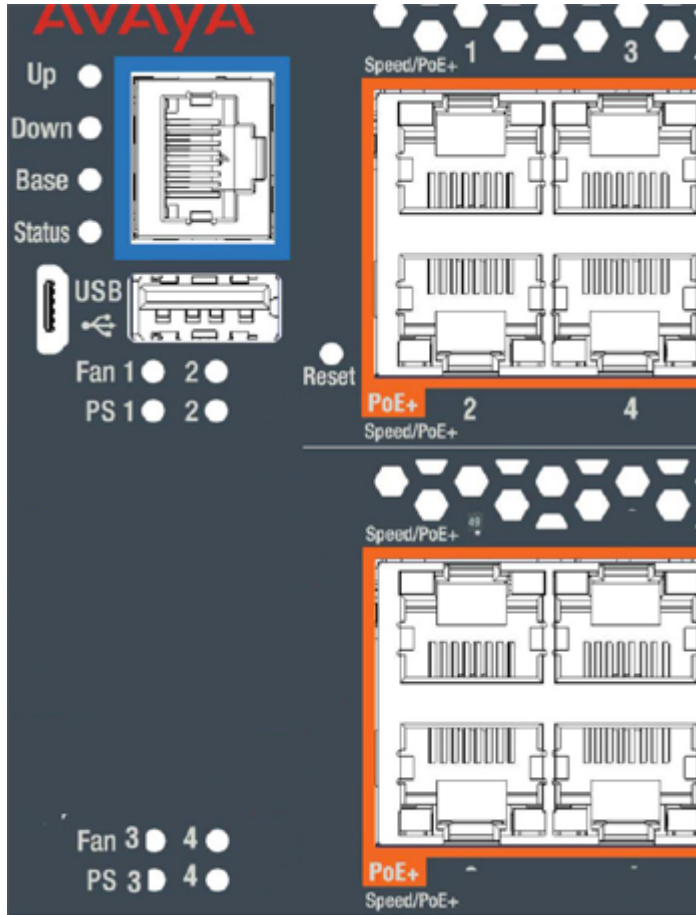


Figure 28: Status LEDs for ERS 5900 switch



**Figure 29: Status LEDs for ERS 59100 switch**


- View the status LED states to verify that the fan trays and power supplies are installed and operating correctly. You can also verify the status and operating mode of the unit.

For status LED state descriptions, see the following table.


**Table 12: Status LED descriptions**

LED	State	Description
Base	Off	The unit is operating in stand-alone mode. If in a Stack, the switch is not a Base unit or a Temporary Base unit.
	Amber (Solid)	The unit is operating as the Temporary Base unit.
	Amber (Blinking)	The unit has a Base unit election problem. Multiple units are configured with a Base unit switch on, or no unit has the Base unit switch on.

*Table continues...*

LED	State	Description
	Amber (Fast Flashing)	The unit did not join the Stack. Refer to the log for more information.
	Emerald (Solid)	The unit is operating as the Base unit in a Stack.
	Emerald (Blinking)	The unit joined the Stack and Automatic Unit Replacement is upgrading the diagnostics, agent, or configuration file.
Status	Off	The unit is not operating.
	Amber (Solid)	The unit encountered an error during diagnostics.
	Amber (Blinking)	The unit is booting. During boot the unit executes the boot loader and diagnostics.
	Emerald (Solid)	The unit is operating normally. Agent software is loaded.
	Emerald (Blinking)	The unit is loading the agent software.
Up/Down	Off	A Cascade Up or Down cable is not detected or connected to an adjacent unit.
	Amber (Solid)	A Cascade Up or Down cable is detected and connected to an adjacent unit, but adjacency with the neighbor is not complete.
	Emerald (Solid)	A Cascade Up or Down cable is detected and connected to an adjacent unit. Adjacency with the neighbor is complete.
	Emerald (Blinking)	The unit formed a partial neighbor with an adjacent unit. Check the Cascade Up and Down cable connections.  <div style="display: flex; align-items: center;"> <div style="margin-right: 5px;"></div> <div> <p><b>Note:</b></p> <p>If rear port mode is enabled, both Up and Down LEDs blink Emerald in synchronization. The Base LED is off.</p> </div> </div>
PS 1 / PS 2 / PS 3 / PS 4	Off	The power supply in slot 1, 2, 3, or 4 is not connected to a power source.
	Amber (Solid)	The power supply in slot 1, 2, 3, or 4 is removed after operating (non-service-affecting).
	Amber (Blinking)	The power supply in slot 1, 2, 3, or 4 is installed, but not providing power to the switch (non-service-affecting).
	Emerald (Solid)	The power supply in slot 1, 2, 3, or 4 is operating normally.

*Table continues...*

LED	State	Description
	Emerald (Blinking)	The power supply in slot 1, 2, 3, or 4 is disconnected from power after operating (non-service-affecting).
	Emerald / Amber (Alternating)	The power supply in slot 2 is operating, but the airflow mode does not match the power supply in slot 1. You must replace the power supply to match the airflow.
Fan 1 / Fan 2 / Fan 3 / Fan 4	Ruby (Solid)	<p>If both fan LEDs are ruby, the unit shut down from an over-voltage fault or an over-temperature fault.</p> <p>For an over-voltage fault, the unit shuts down within 4 seconds. For an over-temperature fault, the unit shuts down immediately.</p> <p> <b>Note:</b></p> <p>The unit software monitors the internal temperature and generates log and SNMP traps to indicate that the unit is running above the high-temperature threshold and is approaching a critical over-temperature fault.</p>
	Ruby (Blinking)	The fan tray in position 1, 2, 3, or 4 is missing. You must install a fan tray, and the fan tray must match the airflow mode of the power supply.
	Ruby (Fast Blinking)	The fan tray in position 1, 2, 3, or 4 is connected but is not operating. Replace the failed fan tray.
	Sapphire (Solid)	The fan tray in position 1, 2, 3, or 4 is front to back airflow and is operating normally.
	Sapphire (Blinking)	The fan tray in position 1, 2, 3, or 4 is front to back airflow and has degraded. Check for a fan failure and replace if necessary.
	Amethyst (Solid)	The fan tray in position 1, 2, 3, or 4 is back to front airflow and is operating normally.
	Amethyst (Blinking)	The fan tray in position 1, 2, 3, or 4 is back to front airflow and has degraded. Check for a fan failure and replace if necessary.
	Amethyst / Ruby (Alternating)	The fan tray in position 1, 2, 3, or 4 does not match the front to back airflow mode of the power supply. You must replace the fan tray with a front to back airflow model.
	Sapphire / Ruby (Alternating)	The fan tray in position 1, 2, 3, or 4 does not match the back to front airflow mode of the

*Table continues...*

LED	State	Description
		power supply. You must replace the fan tray with a back to front airflow model.
	Sapphire (Blink x3) / Ruby (Solid)	The fan tray in position 1, 2, 3, or 4 has degraded and does not match the front to back airflow mode of the power supply. You must replace the fan tray with a front to back airflow model.
	Amethyst (Blink x3) / Ruby (Solid)	The fan tray in position 1, 2, 3, or 4 has degraded and does not match the back to front airflow mode of the power supply. You must replace the fan tray with a back to front airflow model.

**Table 13: Shared SFP transceiver Port LED state indicators**

Label	Color / Status	Description
In Use	Green / steady	The port has a link established.
	Off	The port does not have a link established.
LNK/ACT	Green / steady	This link is operating normally.
	Green / blinking	There is activity on the port.
	Green / slow blinking	The port has been disabled by the software.
	Off	Indicates that the link has been lost.

---

## IP address information configuration

### About this task

The following sections contain information necessary to configure IP address parameters on the switch.

---

## Connecting a console

This procedure describes the steps to connect a console.

### Before you begin

- Terminal with AC power cord and keyboard.
- Serial cable with a DB-9 female connector on both ends. The maximum length for the console port cable is 25 feet (8.3 meters).

### Procedure

1. Connect one end of serial cable to the DB-9 connector on the terminal.

2. Connect the other end of the serial cable to the DB-9 connector on the switch.
3. Turn the terminal on.

---

## Accessing the console menu

### About this task

This procedure describes the steps used to access the console menu.

### Procedure

1. Connect a terminal to the console port of the switch.
2. Set the terminal protocol on the terminal or terminal emulation program to VT100 and VT100/ANSI.
3. Connect to the switch using the terminal or terminal emulation application.
4. After the Avaya banner is displayed, press CTRL + Y to display the main menu. The version of the main menu displayed is dependent on whether the switch is part of a standalone or stacked switch configuration.

---

## Assigning IP parameters using the console menu

### About this task

This procedure describes the steps used to assign IP parameters using the console menu.

### Procedure

1. From the console menu, select IP Configuration/Setup.
2. Assign an IP address to the switch.
  - For a standalone switch, enter a value in the In-Band Switch IP Address field in dotted-decimal notation.
  - For a stack configuration, enter a value in the In-Band Stack IP Address field in dotted-decimal notation.
3. In the In-Band Subnet Mask field enter the appropriate subnet mask in dotted-decimal notation.
4. In the Default Gateway field, enter the appropriate default gateway in dotted-decimal notation.
5. Press CTRL + C to return to the main menu.

---

## Assigning IP parameters using the console menu and ACLI

### Procedure

1. Connect a terminal to the console port of the switch.
2. Set the terminal protocol on the terminal or terminal emulation program to VT100 and VT100/ANSI.
3. Connect to the switch using the terminal or terminal emulation application.
4. After the Avaya banner is displayed, press CTRL + Y to display the main menu.
5. Select **Command Line Interface** . . . from the main menu.
6. Enter the Global Configuration command mode using the **enable** and **configure terminal** commands.
7. In the Global Configuration command mode, use the **ip address** command to set the switch or stack IP address.
8. Initial IP configuration is now complete. To continue with configuration operations, use the appropriate CLI commands. To disconnect from the switch use the **logout** command to return to the Console Menu and select **Logout** from the main menu.

### Job aid

Any terminal or PC with an appropriate terminal emulator can be used as the management station. The following table lists the parameters that must be used with any terminal emulation software used to connect to the switch.

**Table 14: Terminal emulation settings**

Property	Value
Baud Rate	9600 bps
Data Bits	8
Stop Bits	1
Parity	None
Flow Control	None

---

## Assigning IP parameters using Enterprise Device Manager

### About this task

The following procedure describes how to use Quick Start to assign IP parameters to the Ethernet Routing Switch 5900 Series.

## Procedure

1. Connect a computer to the switch through a data port using a standard RJ-45 network cable.
2. Open a Web browser on the attached computer.
3. Enter the factory default IP address of the switch in the following format: `http://<IPAddress>`.

The main screen of the Enterprise Device Manager Interface opens.

4. In the navigation pane, click **Administration > Quick Start**.

The IP/Community/Vlan work area opens.

5. In the In-Band Stack IP Address dialog box, type a switch or stack IP address .
6. In the In-Band Subnet Mask dialog box, type a subnet mask.
7. In the Default Gateway dialog box, type an IP address.
8. Click **Apply**.

### **Note:**

For more information about switch configuration, see *Quick Start Configuration for Avaya Ethernet Routing Switch 4900 and 5900 Series*, NN47211-500.

---

## Verifying assigned IP address is reachable

This procedure describes a method of verifying that the assigned IP address is reachable.

### Before you begin

- Ensure you have assigned an IP address to the switch.
- Physically connect the switch to the network.
- Ensure the terminal from which you ping the switch is on the same network as the switch.

### Procedure

Ping the 5900 Series switch from a terminal or workstation that is on the same network. If the network device sends a ping reply, a message indicates that the specified IP address is alive and can communicate with other devices.



# Chapter 6: Installation reference

## About this task

This section provides reference information for the Ethernet Routing Switch 5900 Series.

---

## Console and management connections

The left front panel of the switch contains the Status LEDs, Console port, Out of Band Management port, and a USB 2.1 port, as well as a micro-USB Type B port (reserved).

The rear panel of the switch contains the Base Unit switch and the Out of Band Management port.

### Console port

The console port is the RJ45 port with a blue border outline. You can use the console port to establish a management terminal connection to the switch. You can use an RJ45 to DB-9 cable, or a DB-9 to RJ45 adapter to connect the switch console port to your management terminal. The maximum length of a console cable is 25 feet (8.3 meters). The following figure and table describe the RJ45 console port pin-out information. You can use the pin-out information to verify or create a console cable for use with your maintenance terminal.

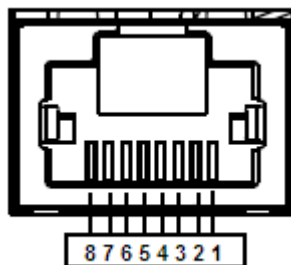


Figure 30: RJ45 console port pin-out

Table 15: Console port pin-out

RJ45 console port pin-out	Signal	Requirement
1	RTS (ready to send)	Optional (can be swapped or linked with pin 8)

*Table continues...*

RJ45 console port pin-out	Signal	Requirement
2	DTR (data terminal ready)	Optional
3	TXD (transmit data)	Mandatory
4	DCD (carrier detect)	Optional
5	GND (ground)	Mandatory
6	RXD (receive data)	Mandatory
7	DSR (data set ready)	Optional
8	CTS (clear to send)	Optional (can be swapped or linked with pin 1)

### Out of Band Management port

The Out of Band Management port is the right-most RJ45 port on the rear panel. The port supports 10/100/1000 Ethernet connections. The Out of Band Management port is available for use when the switch is running diagnostic or agent software. You can use the Out of Band Management port to perform an emergency TFTP download of diagnostic or agent software to the switch. When you perform a TFTP download, an IP address is temporarily assigned to the management port which enables the switch to receive files from the TFTP server.

When the switch is running agent software, you can use the Out of Band Management port configured with an out of band management IP and gateway for remote management. For more information about Out of Band Management configuration, see *Quick Start Configuration for Avaya Ethernet Routing Switch 4900 and 5900 Series*, NN47211-500.

### USB port

The USB port is a Standard Type-A female USB 2.1 port. The switch provides USB host functionality and can support USB flash drives.

---

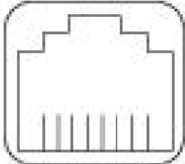
## RJ-45 connector pin assignments

The following section outlines the connector pin assignments for the RJ-45 connectors in the Ethernet Routing Switch 5900 Series.

---

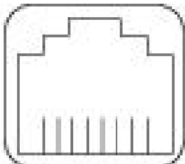
### Avaya Ethernet Routing Switch 5900 non-PoE

The following table outlines the RJ-45 connector pin assignments in the Avaya Ethernet Routing Switch 5900 Series non-PoE switches.

Connector	Pin Number	Signal for 10/100Base-T MDI configuration	Signal for 10/100Base-T MDI-X configuration
 87654321	1	Output transmit data + (TX+)	Input receive data + (RX+)
	2	Output transmit data - (TX-)	Input receive data - (RX-)
	3	Input receive data + (RX+)	Output transmit data + (TX+)
	6	Input receive data + (RX+)	Output transmit data + (TX+)
	4, 5, 7, 8	Not used	Not used
	Pin Number	Signal for 1GBase-T MDI configuration	Signal for 1GBase-T MDI-X configuration
	1	TP0+	TP1+
	2	TP0-	TP1-
	3	TP1+	TP0+
	4	TP2+	TP3+
	5	TP2-	TP3-
	6	TP1-	TP0-
	7	TP3+	TP2+
8	TP3-	TP2-	

## Avaya Ethernet Routing Switch 5900 Series PoE

The following table outlines the RJ-45 connector pin assignments in the Avaya Ethernet Routing Switch 5900 Series PoE switches.

Connector	Pin Number	Signal for 10/100Base-T MDI configuration	Signal for 10/100Base-T MDI-X configuration
 87654321	1	RX+/power+	Receive Data+/power+
	2	RX-/power+	Receive Data-/power+
	3	TX+/power-	Transmit Data+/power-
	4	Not applicable	Not applicable
	5	Not applicable	Not applicable
	6	TX-/power-	Transmit Data-/power-
	7	Not applicable	Not applicable
	8	Not applicable	Not applicable

# Chapter 7: Resources

---

## Support

Go to the Avaya Support website at <http://support.avaya.com> for the most up-to-date documentation, product notices, and knowledge articles. You can also search for release notes, downloads, and resolutions to issues. Use the online service request system to create a service request. Chat with live agents to get answers to questions, or request an agent to connect you to a support team if an issue requires additional expertise.

---

## Documentation

For a list of the documentation for this product and more information about documents on how to configure other switch features, see *Documentation Reference for Avaya Ethernet Routing Switch 4900 and 5900 Series*, NN47211-103.

For more information on new features of the switch and important information about the latest release, see *Release Notes for Avaya Ethernet Routing Switch 4900 and 5900 Series*, NN47211-400.

For more information about how to configure security, see *Configuring Security on Avaya Ethernet Routing Switch 4900 and 5900 Series*, NN47211-505.

For the current documentation, see the Avaya Support web site: [www.avaya.com/support](http://www.avaya.com/support).

---

## Training

Ongoing product training is available. For more information or to register, see <http://avaya-learning.com/>.

Enter the course code in the **Search** field and click **Go** to search for the course.

Course code	Course title
8D00020E	Stackable ERS and VSP Products Virtual Campus Offering

---

## Viewing Avaya Mentor videos

Avaya Mentor videos provide technical content on how to install, configure, and troubleshoot Avaya products.

### About this task

Videos are available on the Avaya Support website, listed under the video document type, and on the Avaya-run channel on YouTube.

### Procedure

- To find videos on the Avaya Support website, go to <http://support.avaya.com> and perform one of the following actions:
  - In **Search**, type `Avaya Mentor Videos` to see a list of the available videos.
  - In **Search**, type the product name. On the Search Results page, select **Video** in the **Content Type** column on the left.
- To find the Avaya Mentor videos on YouTube, go to [www.youtube.com/AvayaMentor](http://www.youtube.com/AvayaMentor) and perform one of the following actions:
  - Enter a key word or key words in the **Search Channel** to search for a specific product or topic.
  - Scroll down Playlists, and click the name of a topic to see the available list of videos posted on the website.

 **Note:**

Videos are not available for all products.

---

## Searching a documentation collection

On the Avaya Support website, you can download the documentation library for a specific product and software release to perform searches across an entire document collection. For example, you can perform a single, simultaneous search across the collection to quickly find all occurrences of a particular feature. Use this procedure to perform an index search of your documentation collection.

### Before you begin

- Download the documentation collection zip file to your local computer.
- You must have Adobe Acrobat or Adobe Reader installed on your computer.

### Procedure

1. Extract the document collection zip file into a folder.
2. Navigate to the folder that contains the extracted files and open the file named `<product_name_release>.pdx`.

3. In the Search dialog box, select the option **In the index named <product\_name\_release>.pdx**.
4. Enter a search word or phrase.
5. Select any of the following to narrow your search:
  - Whole Words Only
  - Case-Sensitive
  - Include Bookmarks
  - Include Comments
6. Click **Search**.

The search results show the number of documents and instances found. You can sort the search results by Relevance Ranking, Date Modified, Filename, or Location. The default is Relevance Ranking.

---

## Subscribing to e-notifications

Subscribe to e-notifications to receive an email notification when documents are added to or changed on the Avaya Support website.

### About this task

You can subscribe to different types of general notifications, for example, Product Correction Notices (PCN), which apply to any product or a specific product. You can also subscribe to specific types of documentation for a specific product, for example, Application & Technical Notes for Virtual Services Platform 7000.

### Procedure

1. In an Internet browser, go to <https://support.avaya.com>.
2. Type your username and password, and then click **Login**.
3. Under **My Information**, select **SSO login Profile**.
4. Click **E-NOTIFICATIONS**.
5. In the GENERAL NOTIFICATIONS area, select the required documentation types, and then click **UPDATE**.

GENERAL NOTIFICATIONS

1/5 Notifications Selected

End of Sale and/or Manufacturer Support Notices	<input type="checkbox"/>
Product Correction Notices (PCN)	<input checked="" type="checkbox"/>
Product Support Notices	<input type="checkbox"/>
Security Advisories	<input type="checkbox"/>
Services Support Notices	<input type="checkbox"/>

UPDATE >>

6. Click **OK**.
7. In the PRODUCT NOTIFICATIONS area, click **Add More Products**.

PRODUCT NOTIFICATIONS

Show Details

Add More Products

1 Notices

8. Scroll through the list, and then select the product name.
9. Select a release version.
10. Select the check box next to the required documentation types.

PRODUCTS	My Notifications
Virtual Services Platform 7000	
Virtualization Provisioning Service	
Visual Messenger™ for OCTEL® 250/350	
Visual Vectors	
Visualization Performance and Fault Manager	
Voice Portal	
Voice over IP Monitoring	
W310 Wireless LAN Gateway	
WLAN 2200 Series	
WLAN Handset 2200 Series	

VIRTUAL SERVICES PLATFORM 7000	
Select a Release Version	
All and Future	
Administration and System Programming	<input type="checkbox"/>
Application Developer Information	<input type="checkbox"/>
Application Notes	<input type="checkbox"/>
Application and Technical Notes	<input checked="" type="checkbox"/>
Declarations of Conformity	<input type="checkbox"/>
Documentation Library	<input checked="" type="checkbox"/>
<b>SUBMIT &gt;&gt;</b>	

11. Click **Submit**.



# Appendix A: Translations of safety messages

This module contains translations of the safety messages found in the Avaya Ethernet Routing Switch 5900 Series documentation suite.

---

## Safety messages

 **Caution:**

When mounting this device in a rack, do not stack units directly on top of one another in the rack. Each unit must be secured to the rack with appropriate mounting brackets. Mounting brackets are not designed to support multiple units.

 **Important:**

**Achtung:** Wenn diese Einheit in einem Rack montiert wird, muß ein gewisser Abstand zur nächsten Einheit gelassen werden. Jede Einheit muß mit geeignetem Befestigungsmaterial gesichert werden. Das Befestigungsmaterial ist nicht für die gleichzeitige Befestigung mehrerer Einheiten geeignet.

 **Important:**

Si vous installez le module dans une baie, ne l'empilez pas directement sur un autre. Chaque module doit être fixé à sa propre baie à l'aide des supports de montage appropriés. Ces supports ne sont pas conçus pour résister à plusieurs modules.


 **Important:**


**Precaución:** Cuando monte este dispositivo en un bastidor, no apile las unidades directamente una encima de otra. Cada unidad debe fijarse en el bastidor con las abrazaderas de montaje adecuadas. Las abrazaderas de montaje no están diseñadas para sostener varias unidades.

 **Important:**

Se il dispositivo viene installato in un rack, non impilare le unità direttamente una sull'altra. Ogni unità deve essere fissata al rack con le staffe di montaggio appropriate. Le staffe di montaggio non sono state progettate per supportare più unità.

 **警告：**在机架中安装此设备时，请勿将多个部件叠放在机架中。必须用合适的安装托架将各个部件固定在机架中。安装托架无法支撑多个部件。

 **注意：**この装置をラックに設置する場合は、ラック内のユニットを直接積み重ねないようにしてください。各ユニットは専用の取り付けブラケットでラックに固定する必要があります。取り付けブラケットは複数のユニットを支えるようには設計されていません。

 **注意：**在機箱中掛載此裝置時，請不要直接在機箱中的另一個裝置上直接堆放裝置。每一裝置都必須使用適當的掛載托架以固定在機架中。掛載托架不能用來支撐多個裝置。

 **Caution:**

If you are not installing a module in the slot, be sure to keep the metal cover plate in place over the slot. Removing the cover plate impedes airflow and proper cooling of the unit.

 **Important:**

**Achtung:** Wenn Sie kein Modul im Schacht verwenden, muß die Metallabdeckung über dem Schacht montiert sein. Eine Entfernung der Abdeckung führt zu einer Verschlechterung der Luftzirkulation und damit zu einer nicht ausreichenden Kühlung der Einheit.

 **Important:**


Si vous n'installez pas le module dans une baie, veuillez à laisser la plaque métallique sur la baie. Si vous la retirez, l'aération du module ne peut pas s'effectuer correctement.


 **Important:**


**Precaution:** Si no instala ningún módulo en la ranura, asegúrese de mantener la placa de la cubierta de metal en la misma. Si la retira, impedirá que el aire circule y la unidad se refrigere adecuadamente.


 **Important:**


**Attenzione:** Se nello slot non vengono installati moduli, assicurarsi di mantenere la piastra di copertura metallica in sede sopra lo slot. La rimozione della piastra impedisce la ventilazione e il corretto raffreddamento dell'unità.

 **注意：**この装置をラックに設置する場合は、ラック内のユニットを直接積み重ねないようにしてください。各ユニットは専用の取り付けブラケットでラックに固定する必要があります。取り付けブラケットは複数のユニットを支えるようには設計されていません。

 **注意：**スロットにモジュールを取り付けない場合は、スロットにある金属製のカバープレートが外れないように注意してください。カバープレートを動かすと気流が妨げられ、適切なユニット冷却が行われなくなります。

 **警告：**如果您不打算在该插槽中安装任何模块，请务必使金属盖板正确地盖住该插槽。如果取下盖板，将妨碍通风及部件散热。

 **注意：**如果您未在插槽中安装模组，请确定金属盖板正确地盖在插槽上。移除盖板会阻碍空气流通以及装置的适当冷卻度。

 **警告：**若要關閉此裝置的電源，拔掉插頭是唯一的方法。為了因應緊急狀況，請將電源線連接到可以快速插拔的地方。

 **Warning:**


Disconnecting the AC power cord is the only way to turn off AC power to this device. Always connect the AC power cord in a location that can be reached quickly and safely in case of an emergency.

 **Important:**

**Warnung:** Das Gerät kann nur durch Ziehen des Netzsteckers ausgeschaltet werden. Schließen Sie das Netzkabel an einer Steckdose an, die in Notfällen schnell und sicher zugänglich ist.

 **Important:**

**Avertissement:** Pour mettre le module hors tension, vous devez impérativement déconnecter le cordon d'alimentation. En outre, vous devez dégager un espace minimal dans la zone de câblage pour pouvoir y accéder facilement en cas d'urgence.

 **警告：**断开交流电源线是切断本设备的交流电源的唯一方法。交流电源线一定要连接到在紧急时刻可以快速安全地接触到的位置。

 **Important:**

**Advertencia:** Para apagar el dispositivo debe desenchufar el cable. Conecte siempre el cable de alimentación a una toma segura y de fácil acceso por si se produjera alguna situación de emergencia.

 **Important:**

**Avviso:** L'unico modo per disattivare questo dispositivo consiste nello scollegare il cavo di alimentazione. Collegare sempre il cavo di alimentazione ad una presa che sia facilmente e rapidamente accessibile in caso di emergenza.

 **Danger:**

Use only power cords that have a grounding path. Without a proper ground, a person who touches the switch is in danger of receiving an electrical shock. Lack of a grounding path to the switch may result in excessive emissions.

 **Important:**

**Vorsicht:** Verwenden Sie nur Netzkabel mit Schutzerdung. Ohne ordnungsgemäße Schutzerdung besteht für Personen, die den Switch berühren, die Gefahr eines elektrischen Schlages. Eine nichtvorhandene Schutzerdung kann zu sehr starken Abstrahlungen führen.

 **Danger:**

N'utilisez que des cordons d'alimentation équipés de trajet de mise à la terre. Sans mise à la terre adaptée, vous risquez de recevoir une décharge électrique en touchant le commutateur. Par ailleurs, l'absence de trajet de mise à la terre peut générer des émissions excessives.

 **Important:**

Peligro: Utilice únicamente cables de alimentación con toma de tierra. De lo contrario, al tocar el interruptor puede recibir una descarga eléctrica. Si no hay un circuito de toma de tierra en el enchufe, puede producirse un exceso de emisiones.

 **Important:**

**Pericolo:** Utilizzare esclusivamente cavi di alimentazione dotati di un percorso per la messa a terra. Senza un'adeguata messa a terra, chiunque tocchi lo switch corre il rischio di ricevere una scossa elettrica. L'assenza di un percorso per la messa a terra verso lo switch può comportare un eccesso di emissioni.



**危険:** 接地経路を持つ電源コードを必ず使用するようになしてください。適切な接地がない状態でスイッチに触ると、感電する危険性があります。また、スイッチへの接地経路がないと、過度な放電を引き起こす可能性があります。



**危险:** 请仅使用接地的电源线。如果电源线不接地或接地不当, 接触交换机的人员可能会受到电击。如果交换机不接地, 则可能导致放电过量。