



NORTEL

Nortel Ethernet Routing Switch 5000 Series

Installation — SFPs and XFPs

Release: 6.2

Document Revision: 03.01

www.nortel.com

NN47200-302

Nortel Ethernet Routing Switch 5000 Series

Release: 6.2

Publication: NN47200-302

Document release date: 28 June 2010

Copyright © 2007-2010 Nortel Networks. All Rights Reserved.

While the information in this document is believed to be accurate and reliable, except as otherwise expressly agreed to in writing NORTEL PROVIDES THIS DOCUMENT "AS IS" WITHOUT WARRANTY OR CONDITION OF ANY KIND, EITHER EXPRESS OR IMPLIED. The information and/or products described in this document are subject to change without notice.

Nortel, Nortel Networks, the Nortel logo, and the Globemark are trademarks of Nortel Networks.

CleTOP is a trademark of NTT-ME Corporation.

IEEE is a trademark of the Institute of Electrical and Electronics Engineers, Inc.

Lucent is a trademark of Lucent Technologies, Inc.

All other trademarks are the property of their respective owners.

Contents

New in this release	5
Features 5	
Support for additional SFPs 5	
Introduction	7
Safety and equipment care information	9
Handling, safety, and environmental guidelines 9	
Electrostatic discharge prevention 9	
Care of fiber optic equipment 10	
Fiber optic cable care 10	
Fiber optic connector care 11	
Cleaning single connectors 12	
Cleaning duplex connectors 13	
Cleaning receptacles 14	
Product safety warnings and information 16	
ESD and installation caution messages 16	
Laser safety warnings 17	
Small form factor pluggable transceivers	21
Selecting an SFP 21	
Job aid 22	
Job aid 22	
Job aid 23	
Installing an SFP 24	
Job aid 26	
Removing an SFP 27	
SFP specifications	29
SFP labels 30	
General SFP specifications 30	
100BASE-FX SFP specifications 31	
T1 SFP specifications 31	
T1 SFP—default settings 34	
1000BASE-T SFP specifications 35	
1000BASE-SX (LC) SFP specifications 35	

1000BASE-SX (MT-RJ) SFP specifications	36
1000BASE-LX SFP specifications	37
1000BASE-XD CWDM SFP specifications	37
1000BASE-ZX CWDM SFP specifications	38
1000BASE-SX DDI SFP specifications	39
1000BASE-LX DDI SFP specifications	39
1000BASE-XD DDI 1310 nm SFP specifications	40
1000BASE-XD DDI 1550 nm SFP specifications	40
1000BASE-ZX DDI SFP specifications	41
1000BASE-XD DDI CWDM SFP specifications	42
1000BASE-ZX DDI CWDM SFP specifications	42
1000BASE-BX10 DDI SFP specifications	43
1000BASE-BX40 DDI SFP specifications	44
1000BASE-EX DDI SFP specifications	45

10 Gigabit small form factor pluggable transceivers **47**

Selecting an XFP	47
Job aid	48
Installing an XFP	49
Removing an XFP	51

XFP specifications **53**

XFP labels	53
General XFP specifications	54
10GBASE-SR XFP specifications	54
10GBASE-LRM XFP specifications	56
10GBASE-LR/LW XFP specifications	58
10GBASE-ER/EW XFP specifications	60
10GBASE-ZR/ZW XFP specifications	61

Index **63**

New in this release

The following sections detail what's new in *Nortel Ethernet Routing Switch 5000 Series Installation — SFPs (NN47200-302)* for release 6.2.

Features

See the following sections for information about feature changes.

Support for additional SFPs

The 5000 Series switches support eight additional SFPs in Release 6.2. See the following for more information:

- [“T1 SFP specifications” \(page 31\)](#)
- [“1000BASE-XD DDI 1310 nm SFP specifications” \(page 40\)](#)
- [“1000BASE-XD DDI 1550 nm SFP specifications” \(page 40\)](#)
- [“1000BASE-ZX DDI SFP specifications” \(page 41\)](#)
- [“1000BASE-XD DDI CWDM SFP specifications” \(page 42\)](#)
- [“1000BASE-ZX DDI CWDM SFP specifications” \(page 42\)](#)
- [“1000BASE-BX40 DDI SFP specifications” \(page 44\)](#)
- [“1000BASE-EX DDI SFP specifications” \(page 45\)](#)

Introduction

This document provides installation instructions and technical specifications for Small Form Factor Pluggable (SFP) transceivers.

For a list of supported SFPs, see your latest product-specific release notes. Information contained in the Release Notes takes precedence over any information contained in this document.

Navigation

- [“Safety and equipment care information” \(page 9\)](#)
- [“Small form factor pluggable transceivers” \(page 21\)](#)
- [“SFP specifications” \(page 29\)](#)
- [“10 Gigabit small form factor pluggable transceivers” \(page 47\)](#)
- [“XFP specifications” \(page 53\)](#)

Safety and equipment care information

This section contains important safety and regulatory information. Read this section before you install small form factor pluggable (SFP) transceivers or 10 gigabit SFP (XFP) transceivers.

Navigation

- [“Handling, safety, and environmental guidelines” \(page 9\)](#)
- [“Care of fiber optic equipment” \(page 10\)](#)
- [“Product safety warnings and information” \(page 16\)](#)

Handling, safety, and environmental guidelines

Before you install an SFP or XFP, read the following handling, safety, and environmental guidelines:

- SFPs and XFPs are static sensitive. For more information about how to prevent damage from electrostatic discharge (ESD), see [“Electrostatic discharge prevention” \(page 9\)](#).
- Dust contamination can reduce the performance of optical parts in SFPs and XFPs. When you store an SFP or XFP, or after you disconnect it from a fiber optic cable, always keep a dust cover over the optical bore.
- Dispose of this product according to all national laws and regulations.

Electrostatic discharge prevention

To prevent equipment damage, observe the following electrostatic discharge (ESD) precautions when you handle or install the components.

- Ground yourself and the equipment to an earth or building ground. Use a grounded workbench mat (or foam that dissipates static charge) and a grounding wrist strap. The wrist strap must touch the skin and be grounded through a one megaohm resistor.
- Do not touch anyone who is not grounded.

- Leave all components in their ESD-safe packaging until installation, and use only a static-shielding bag for all storage, transport, and handling.
- Clear the area of synthetic materials such as polyester, plastic, vinyl, or styrofoam because these materials carry static electricity that damages the equipment.

Care of fiber optic equipment

You must keep fiber optic equipment connections clean and damage-free. Use the information in this section to properly maintain and care for fiber optic equipment.

Care of fiber optic equipment navigation

- [“Fiber optic cable care” \(page 10\)](#)
- [“Fiber optic connector care” \(page 11\)](#)
- [“Cleaning single connectors” \(page 12\)](#)
- [“Cleaning duplex connectors” \(page 13\)](#)
- [“Cleaning receptacles” \(page 14\)](#)

Fiber optic cable care

Although the glass fiber in fiber optic cable is protected with reinforcing material and plastic insulation, it is subject to damage. Use the following precautions to avoid damaging the glass fiber.

- Do not kink, knot, or vigorously flex the cable.
- Do not bend the cable to less than a 40 mm radius.
- Do not stand on fiber optic cable; keep the cable off the floor.
- Do not pull fiber optic cable harder than you do a cable containing copper wire of comparable size.
- Do not allow a static load of more than a few pounds on a section of the cable.
- Place protective caps on fiber optic connectors that are not in use.
- Store unused fiber optic patch cables in a cabinet, on a cable rack, or flat on a shelf.

Frequent overstressing of fiber optic cable causes progressive degeneration that leads to failure.

If you suspect damage to a fiber optic cable, either due to mishandling or an abnormally high error rate observed in one direction, reverse the cable pairs. If the high error rate appears in the other direction, replace the cable.

**CAUTION****Risk of equipment damage**

Do not crush fiber optic cable. If fiber optic cable is in the same tray or duct with large, heavy electrical cables, it can be damaged by the weight of the electrical cable.

Fiber optic connector care

Before connecting fiber optic connectors to transmission equipment, test equipment, patch panels, or other connectors, ensure fiber optic connectors are clean. The performance of an optical fiber connector depends on how clean the connector and coupling are at the time of connection.

A damaged or dirty connector can damage a connector with which it pairs. A connector must be absolutely clean before you insert it into a transmitter or receiver.

Never clean an optical connector while it carries light. Optical power can cause ignition of the cleaning material when it contacts the end of the optical connector and destroy the connector. Typical cleaning materials, for example, tissues saturated with alcohol, combust almost instantaneously after you expose them to optical power levels of +15 dBm or higher.

Visually inspect the connector to determine cleanliness and to determine if it needs replacing. You must replace a connector that has a scratch across the core, or a scratch that appears to end in the core.

The proper connector cleaning method depends on the connector contaminants:

- Judge cleanliness by visual inspection with a fiber microscope. First inspect the connector, and then clean as required.

**WARNING****Risk of eye injury**

When you inspect a connector, ensure that light sources are off. The light source in fiber optic cables can damage your eyes.

- If you suspect only the possibility of dust particles (for example, which can occur when you leave a connector uncapped in a clean environment), use high-quality canned air or a reel cleaner, for

example, a Cletop, to clean the connector. A reel cleaner is a good choice to ensure that no dust contaminates the connector.

- If the connector is visibly dirty or you suspect it to be contaminated by chemicals (for example, matching gel), use high-quality alcohol and canned air to clean the connector. This method is the most thorough cleaning method. In some cases, a reel cleaner can suffice.

The more surface manipulation you apply to the connector, the more likely the connector is to become damaged.

When you insert a connector ferrule into a connector or adapter, ensure that the ferrule tip does not touch the outside of the mating connector or adapter. This can produce scratches and dirt deposits on the connector.

To help prevent connectors from collecting dust, cover them when not in use. To avoid the transfer of oil or other contaminants from your fingers to the end face of the ferrule, handle connectors with care. Do not touch the connector end face.

Cleaning single connectors

Clean connectors so that the optical signal is minimally attenuated by the connector.

This procedure is appropriate when you suspect more than dust contamination.

Prerequisites

- You need a lens-grade, lint-free tissue, for example, Kimwipes.
- You need an optical-grade isopropyl alcohol (IPA) (98% or more pure).
- You need a high-quality canned compressed air with extension tube.
Compressed air must be free of dust, water, and oil, or filmy deposits or scratches on the surface of the connector can result.
- You need a fiber optic microscope to inspect connectors.



WARNING

Risk of eye injury

When inspecting a connector, ensure that light sources are off. The light source used in fiber optic cables can damage your eyes.

To avoid getting debris in your eyes, wear safety glasses when working with the canned air duster.

To avoid eye irritation on contact, wear safety glasses when working with isopropyl alcohol.

Procedure steps

Step	Action
1	Remove dust or debris by applying canned air to the cylindrical and end-face surfaces of the connector.
2	Gently wipe the cylindrical and end-face surfaces with a tissue dampened with optical-grade isopropyl alcohol.
3	Gently wipe the cylindrical and end-face surfaces with a dry tissue.
<div style="border: 1px solid black; padding: 5px;"> <p>ATTENTION Do not let the IPA evaporate; wipe it dry immediately. Alcohols can leave a residue that is difficult to remove.</p> </div>	
4	Dry the connector surfaces by applying canned air.
5	Inspect the connector to ensure it is clean and undamaged. To prevent contamination, do not touch the connector surfaces after cleaning; and cover connectors with dust caps if you are not going to use them right away.

--End--

Cleaning duplex connectors

Clean connectors so that the optical signal is minimally attenuated by the connector.

This procedure is appropriate when you suspect more than dust contamination.

Prerequisites

- You need a lens-grade, lint-free tissue, for example, Kimwipes.
- You need an optical-grade isopropyl alcohol (IPA) (98% or more pure).
- You need a high-quality canned compressed air with extension tube.
Compressed air must be free of dust, water, and oil, or filmy deposits or scratches on the surface of the connector can result.
- You need a fiber optic microscope to inspect connectors.



WARNING

Risk of eye injury

When you inspect a connector, ensure that light sources are off. The light source in fiber optic cables can damage your eyes.

To avoid getting debris in your eyes, wear safety glasses when you work with the canned air duster.

To avoid eye irritation on contact, wear safety glasses when you work with isopropyl alcohol.

Procedure steps

Step	Action
1	To remove or retract the shroud, do one of the following. <ul style="list-style-type: none">• On removable shroud connectors, hold the shroud on the top and bottom at the letter designation, apply medium pressure, and then pull it free from the connector body. Do not discard the shroud.• On retractable shroud connectors, hold the shroud in its retracted position.
2	Remove dust or debris by applying canned air to the cylindrical and end-face surfaces of the connector.
3	Gently wipe the cylindrical and end-face surfaces of both ferrules using a tissue saturated with optical-grade isopropyl alcohol.
4	Gently wipe the cylindrical and end-face surfaces with a dry tissue.
<div style="border: 1px solid black; padding: 5px;"><p>ATTENTION Do not let the IPA evaporate; wipe it dry immediately. Alcohols can leave a residue that is difficult to remove.</p></div>	
5	Blow dry the connector surfaces with canned air.
6	Inspect the connector to ensure it is clean and undamaged.
7	Using care to not touch the clean ferrules, gently push the shroud back onto the connector until it seats and locks in place.

--End--

Cleaning receptacles

Clean connector receptacles or ports so that the optical signal is minimally attenuated by the connection.

Prerequisites

- You need an optical-grade isopropyl alcohol (IPA) (98% or more pure).
- You need cleaning swabs (also called cleaning sticks or wands).
- You need a high-quality canned compressed air with extension tube.

Compressed air must be free of dust, water, and oil, or filmy deposits or scratches on the surface of the connector can result.



CAUTION

Risk of equipment damage

To avoid contamination, optical ports must only be cleaned when there is evidence of contamination or reduced performance, or during their initial installation.

To prevent oil contamination of connectors, use only high-quality canned compressed air.

Do not allow the air extension tube to touch the bottom of the optical port.

Procedure steps

Step	Action
1	Remove dust or debris by blowing canned air into the optical port of the device using the canned air extension tube.
2	Clean the optical port by inserting a wand moistened with alcohol into the receptacle and rotating it. Each cleaning wand must only be used to clean one optical port.
3	Dry the optical port by inserting a dry wand into the receptacle and rotating it.

ATTENTION

Do not let the IPA evaporate; wipe it dry immediately. Alcohols can leave a residue that is difficult to remove.

- | | |
|---|--|
| 4 | Remove lint by blowing compressed air into the optical port. |
| 5 | Reconnect the optical connector and check for proper function.

If you are not reinstalling the connector, be sure to use a protective cap.

If problems persist, ensure that the connector or receptacle is free from damage. |

--End--

Product safety warnings and information

The products described in this guide meet requirements of:

IEC 60950 3rd edition
CSA 22.2 No. 60950 3rd edition
UL 60950 3rd edition
EN60950 3rd edition
EN60825-1, +A11, +A2

ESD and installation caution messages

This section provides electrostatic discharge (ESD) and installation caution messages.



CAUTION

Risk of equipment damage

To prevent damage from electrostatic discharge, always wear an antistatic wrist strap connected to an ESD jack.



CAUTION

ATTENTION

Risque d'endommagement de l'équipement

Pour prévenir tout dommage dû à une décharge électrostatique, vous devez toujours porter un bracelet antistatique connecté à une prise ESD.



CAUTION

ACHTUNG

Risiko eines Geräteschadens

Risiko eines Geräteschadens Um Schäden durch elektrostatische Entladung zu verhindern, tragen Sie bei der Instandhaltung dieses Produkts immer ein antistatisches Band am Handgelenk, welches mit einer ESD-Buchse verbunden ist.



CAUTION

PRECAUCIÓN

Riesgo de daño del equipo

Para prevenir el daño producido por una descarga electrostática, use siempre una pulsera antiestática conectada a un enchufe ESD.



CAUTION

CUIDADO

Risco de danos ao equipamento

Para evitar danos com descarga eletrostática, sempre use uma pulseira antiestática que esteja conectada a uma tomada ESD.



CAUTION
ATTENZIONE
Rischio di danni all'apparecchiatura

Per evitare danni derivanti da scariche elettrostatiche, indossare sempre un polsino antistatico collegato a una presa ESD.



CAUTION
Risk of equipment damage
Only trained personnel can install this product.



CAUTION
ATTENTION
Risque d'endommagement de l'équipement
L'installation doit être effectuée exclusivement par un personnel qualifié.



CAUTION
ACHTUNG
Risiko eines Geräteschadens
Nur geschultes Personal kann dieses Produkt installieren.



CAUTION
PRECAUCIÓN
Riesgo de daño del equipo
Sólo el personal capacitado puede instalar este producto.



CAUTION
CUIDADO
Risco de danos ao equipamento
Somente pessoal treinado pode instalar este produto.



CAUTION
ATTENZIONE
Rischio di danni all'apparecchiatura
Questo prodotto può essere installato solo da personale esperto.

Laser safety warnings

This section provides laser safety warnings.



8769EB



WARNING

Risk of eye injury by laser

Fiber optic equipment can emit laser or infrared light that can injure your eyes. Never look into an optical fiber or connector port. Always assume that fiber optic cables are connected to a light source.



WARNING

AVERTISSEMENT

Risques de blessure oculaire par lumière laser L'équipement de fibres optiques peut émettre une lumière laser ou infrarouge nuisible à vos yeux. Ne regardez jamais en direction de fibres optiques ou d'un port connecteur. Supposez toujours que les câbles de fibres optiques sont connectés à une source de lumière.



WARNING

WARNUNG

Risiko einer Augenverletzung durch Laser Glasfasergeräte können Laserstrahlen oder ultraviolette Licht aussenden, das Ihre Augen verletzen kann. Schauen Sie nie direkt in einen Glasfaserleiter oder Verbindungsanschluss. Gehen Sie immer davon aus, dass Glasfaserkabel mit einer Lichtquelle verbunden sind.



WARNING

ADVERTENCIA

Riesgo de lesión en los ojos por láser El equipo de fibra óptica puede emitir una luz láser o infrarroja que dañe sus ojos. Nunca mire un puerto de fibra óptica o conector. Siempre asuma que los cables de fibra óptica están conectados a una fuente de luz.



WARNING

AVISO

O laser pode causar ferimentos no olho O equipamento de fibra óptica pode emitir laser ou luz infravermelha que pode causar danos a sua vista. Nunca olhe para dentro da fibra óptica ou da porta do conector. Tenha sempre em mente que os cabos de fibra óptica estão ligados a uma fonte de luz.



WARNING

AVVISO

Rischio di ustioni agli occhi dovute al laser. Le apparecchiature con fibre ottiche possono emettere raggi laser o infrarossi in grado di provocare ferite agli occhi. Non guardare mai all'interno di una porta di connessione o una fibra ottica. Tenere sempre presente che i cavi a fibra ottica sono collegati a una sorgente luminosa.

Small form factor pluggable transceivers

This section describes how to select and install small form factor pluggable (SFP) transceivers.

Use an SFP to connect a device motherboard to a fiber optic or unshielded twisted pair network cable. The SFPs described in this section provide Ethernet at 1 gigabit per second (Gb/s).

Navigation

- [“Selecting an SFP” \(page 21\)](#)
- [“Installing an SFP” \(page 24\)](#)
- [“Removing an SFP” \(page 27\)](#)
- [“SFP specifications” \(page 29\)](#)

Selecting an SFP

Use an SFP transceiver to connect a device motherboard to a fiber optic or unshielded twisted pair network cable. Select the appropriate transceiver to provide the required reach.

Procedure steps

Step	Action
1	Determine the required reach. Depending on the product, SFPs are available for cable distances of up to 100 meters (m), 550 m, 10 kilometers (km), 40 km, 70 km, and 120 km.
2	Determine the required media and connector type. You need fiber optic cable for a reach over 100 m.

- Possible media include CAT5, single mode fiber, and multimode fiber. Possible connectors include Lucent connector (LC), MT-RJ, and RJ-45.
- 3 If the media is optical fiber, determine wavelength restrictions or requirements.
To expand available bandwidth on a common optical fiber, use Coarse Wavelength Division Multiplexing (CWDM) SFPs.
 - 4 Determine if you need digital diagnostic monitoring (DDM).
Not all SFPs or products support DDM.
 - 5 Use the following job aids to determine the appropriate SFP for your application.

--End--

Job aid

The following table describes the reach provided by various SFPs. This table is informational only—not all Nortel Ethernet switching and routing products support all the SFPs listed here.

SFP model	Common application
1000BASE-T	Lowest-cost gigabit Ethernet solution. Up to 100 m reach over Category 5 (CAT5) unshielded twisted pair (UTP).
1000BASE-SX	Well-suited for campus local area networks (LAN) and intrabuilding links. Up to 275 or 550 m reach (fiber-dependent) over a fiber pair.
1000BASE-LX	Up to 10 km reach over a single mode fiber (SMF) pair. Up to 550 m reach over a multimode fiber (MMF) pair.
1000BASE-XD	Up to 40 km reach over a single mode fiber pair.
1000BASE-ZX	Up to 70 km reach over a single mode fiber pair.
1000BASE-BX10	Up to 10 km reach. Bidirectional over one single mode fiber. The 1000BASE-BX10 SFPs are paired devices—for more information, see “1000BASE-BX10 DDI SFP specifications” (page 43).
1000BASE-BX40	Up to 40 km reach. Bidirectional over one single mode fiber. The 1000BASE-BX40 SFPs are paired devices—for more information, see “1000BASE-BX40 DDI SFP specifications” (page 44).
1000BASE-EX	Up to 120 km reach over a single mode fiber pair.

Job aid

SFPs are hot-swappable input and output enhancement components designed for use with Nortel products to allow gigabit Ethernet ports to link with other gigabit Ethernet ports over various media types.

The SFPs described in this section do not have Digital Diagnostic Interface capability, and are RoHS -E5 compliant.

The system also supports CWDM SFPs. CWDM technology consolidates multiple optical channels on a common optical fiber. CWDM uses multiple wavelengths to expand available bandwidth.

CWDM SFPs support high speed data communications for Metropolitan Area Networks (MAN). The system uses a grid of eight CWDM optical wavelengths in both ring and point-to-point configurations. All components are color-coded by wavelength.

ATTENTION

The attainable cable length can vary depending on the quality of the fiber optic cable used.

Model and connector	Product number	Description
1000BASE-SX (LC)	AA1419013-E5	850 (nm), up to 275 or 550 m
1000BASE-SX (MT-RJ)	AA1419014-E5	850 nm, up to 275 or 550 m
1000BASE-LX (LC)	AA1419015-E5	1310 nm, up to 10 km
1000BASE-XD CWDM (LC)	AA1419025-E5 to AA1419032-E5	1470 nm to 1610 nm, up to 40 km
1000BASE-ZX CWDM (LC)	AA1419033-E5 to AA1419040-E5	1470 nm to 1610 nm, up to 70 km
100BASE-FX (LC) NOTE: Only the 5600 Series switches support this SFP.	AA1419074-E6	1310 nanometers (nm), up to 2 km
T1 (RJ-48C)	AA1419075-E6	1.544 Mb/s Fast Ethernet to T1 remote bridge.

For more information about specifications for these SFPs, see [“SFP specifications” \(page 29\)](#).

Job aid

You can use a Digital Diagnostic Indicating (DDI) SFP in an Ethernet Routing Switch module that supports SFPs. The switch supports the optical functions of the SFP. A future release will provide access to the DDI information.

The SFPs described in this section are all RoHS -E6 compliant.

The following table lists and describes the Nortel SFP models with DDI capability. All these SFPs use LC connectors.

Model	Product number	Description
1000BASE-T (RJ-45)	AA1419043-E6	CAT5 UTP, up to 100 m. Because the 1000BASE-T device is all electrical, there is no need for DDI support.
1000BASE-SX	AA1419048-E6	850 nm, up to 275 or 550 m
1000BASE-LX	AA1419049-E6	1310 nm, up to 10 km
1000BASE-XD	AA1419050-E6	1310 nm, up to 40 km
1000BASE-XD	AA1419051-E6	1550 nm, up to 40 km
1000BASE-ZX	AA1419052-E6	1550 nm, up to 70 km
1000BASE-XD CWDM	AA1419053-E6 to AA1419060-E6	1470 nm to 1630 nm, up to 40 km
1000BASE-ZX CWDM	AA1419061-E6 to AA1419068-E6	1470 nm to 1630 nm, up to 70 km
1000BASE-BX (LC type)	AA1419069-E6, AA1419070-E6	Bidirectional 1310 nm and 1490 nm, up to 10 km The 1000BASE-BX SFPs are paired devices—for more information, see “1000BASE-BX10 DDI SFP specifications” (page 43)
1000BASE-EX	AA1419071-E6	1550 nm, up to 120 km
1000BASE-BX (LC type)	AA1419076-E6, AA1419077-E6	Bidirectional 1310 nm and 1490 nm, up to 40 km The 1000BASE-BX SFPs are paired devices—for more information, see “1000BASE-BX40 DDI SFP specifications” (page 44) .

For more information about specifications for these SFPs, see [“SFP specifications” \(page 29\)](#).

Installing an SFP

Install an SFP to provide an interface between the switch and the network cable.

Installing an SFP takes about three minutes.

Prerequisites

- Verify that the SFP is the correct model for your network configuration.
- Before you install the optical connector, ensure it is clean.



WARNING

Risk of eye injury by laser

Fiber optic equipment can emit laser or infrared light that can injure your eyes. Never look into an optical fiber or connector port. Always assume that fiber optic cables are connected to a light source.



CAUTION

Risk of equipment damage

To prevent damage from electrostatic discharge, always wear an antistatic wrist strap connected to an ESD jack.



CAUTION

Risk of equipment damage

Only trained personnel can install this product.

Procedure steps

Step	Action
1	Remove the SFP from its protective packaging.
2	Grasp the SFP between your thumb and forefinger.
3	As shown in the following figure, insert the device into the slot on the module.



CAUTION

Risk of equipment damage

SFPs are keyed to prevent incorrect insertion. If the SFP resists pressure, do not force it; turn it over, and reinsert it.

Apply a light pressure to the device until it clicks and locks into position.

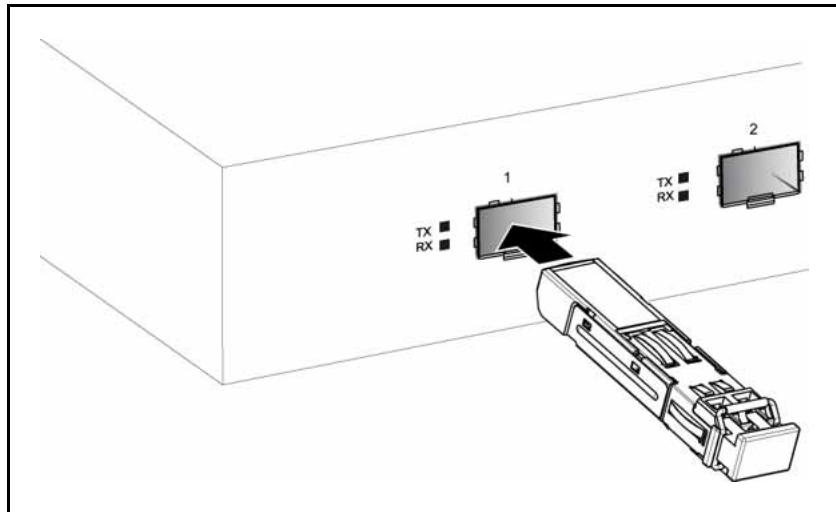

- 4 Remove the dust cover from the optical bore and insert the fiber optic connector.

--End--

Job aid

Depending on the transceiver manufacturer, your SFP transceiver can have various types of locking and extractor mechanisms.

The following figures shows a typical mechanisms used on SFP transceivers; other locking and extractor mechanisms exist, although they are not shown here. In the following figure, the SFP still has the bore plug installed. Pull the bail to release the device.

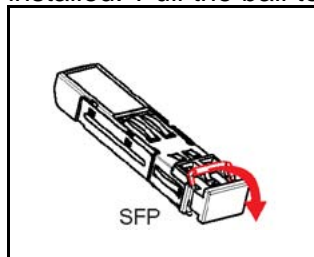

The following figure shows the 1000BASE-SX MT-RJ SFP. Push the tab to release the device.

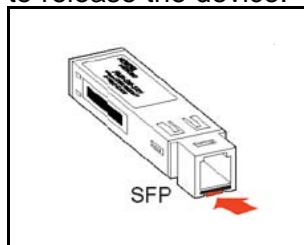

The following figure shows the wrap-around latch-type extraction mechanism. To remove the device, push the collar towards the module.

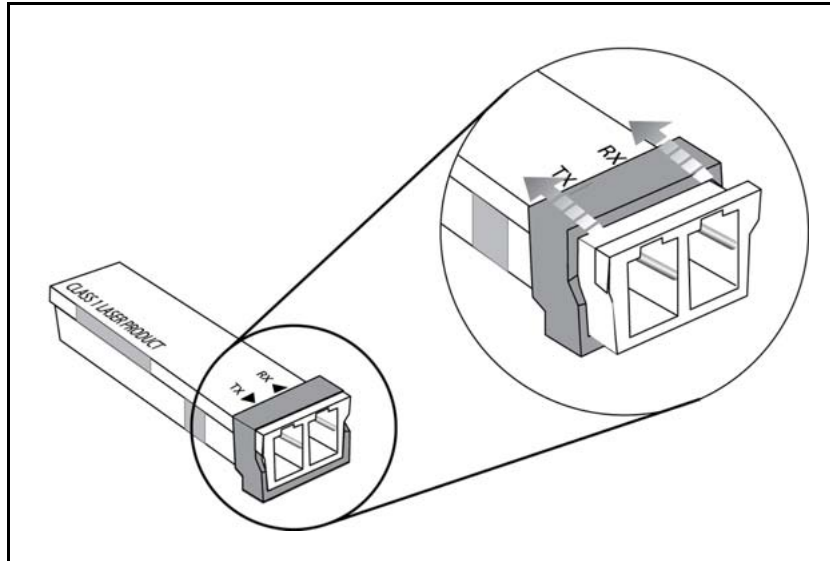

Removing an SFP

Remove an SFP to replace it or to commission it elsewhere.

Prerequisites

- Wear an antistatic wrist strap.



WARNING

Risk of eye injury by laser

Fiber optic equipment can emit laser or infrared light that can injure your eyes. Never look into an optical fiber or connector port. Always assume that fiber optic cables are connected to a light source.



CAUTION

Risk of equipment damage

To prevent damage from electrostatic discharge, always wear an antistatic wrist strap connected to an ESD jack.

Procedure steps

Step	Action
1	Disconnect the network fiber optic cable from the SFP connector.
2	Affix dust covers over the fiber optic bore and connector.
3	Depending on your SFP model, to release the SFP, press the locking and extractor mechanism.
4	Slide the SFP out of the module SFP slot.

If the SFP does not slide easily from the module slot, use a gentle side-to-side rocking motion while firmly pulling the SFP from the slot.

- 5 Store the SFP in a safe place until needed.

ATTENTION

If you discard the SFP, be sure to dispose of it according to all national laws and regulations.

--End--

SFP specifications

This section provides technical specifications for the supported small form factor pluggable (SFP) models. Use this information to aid in proper network design.

The specifications in this section meet or exceed those specified in the applicable IEEE standards, where they exist.

In these specifications, unless otherwise noted, *receiver sensitivity* is the minimum average input optical power for which the receiver is guaranteed to meet the bit error rate (BER) of 10^{-12} .

Navigation

- [“SFP labels” \(page 30\)](#)
- [“General SFP specifications” \(page 30\)](#)
- [“T1 SFP specifications” \(page 31\)](#)
- [“100BASE-FX SFP specifications” \(page 31\)](#)
- [“1000BASE-T SFP specifications” \(page 35\)](#)
- [“1000BASE-SX \(LC\) SFP specifications” \(page 35\)](#)
- [“1000BASE-SX \(MT-RJ\) SFP specifications” \(page 36\)](#)
- [“1000BASE-LX SFP specifications” \(page 37\)](#)
- [“1000BASE-XD CWDM SFP specifications” \(page 37\)](#)
- [“1000BASE-ZX CWDM SFP specifications” \(page 38\)](#)
- [“1000BASE-SX DDI SFP specifications” \(page 39\)](#)
- [“1000BASE-LX DDI SFP specifications” \(page 39\)](#)
- [“1000BASE-XD DDI 1310 nm SFP specifications” \(page 40\)](#)
- [“1000BASE-XD DDI 1550 nm SFP specifications” \(page 40\)](#)
- [“1000BASE-ZX DDI SFP specifications” \(page 41\)](#)
- [“1000BASE-XD DDI CWDM SFP specifications” \(page 42\)](#)

- “1000BASE-ZX DDI CWDM SFP specifications” (page 42)
- “1000BASE-BX10 DDI SFP specifications” (page 43)
- “1000BASE-BX40 DDI SFP specifications” (page 44)
- “1000BASE-EX DDI SFP specifications” (page 45)

SFP labels

The Nortel label on a typical SFP contains a Nortel serial number, a bar code, a manufacturer code, an interface type, and a part number.

Figure 1
SFP label

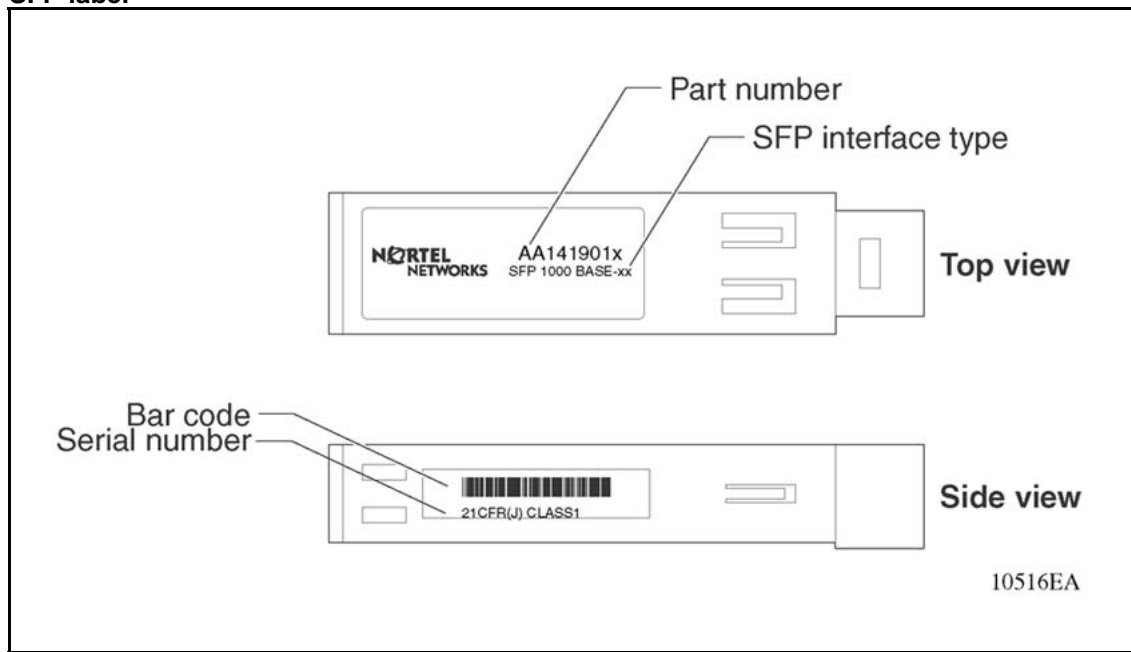

General SFP specifications

The following table describes general SFP specifications.

Table 1
General SFP specifications

Parameter	Description
Dimensions (H x W x D)	13.4 x 8.50 x 56.4 millimeters (mm) 0.53 x 0.33 x 2.22 inches (in.) unless otherwise stated
Operating temperature	- 5 to 85C for RoHS -E6 models 0 to 60C for RoHS -E5 models
Storage temperature	- 40 to 85C

Parameter	Description
Maximum supply current	300 mA unless otherwise stated
Maximum power consumption	1.0 W unless otherwise stated

100BASE-FX SFP specifications

The 100BASE-FX SFP provides 100 Mb/s Ethernet Carrier Sense Multiple Access with Collision Detection (CSMA-CD) connectivity using multimode optical fiber. The part number for this model is AA1419074-E6

The 100BASE-FX SFP is supported on the 5600 Series switches, but not on the 5500 Series switches.

The following table describes the 100BASE-FX SFP specifications.

Table 2
100BASE-FX SFP specifications

Parameter	Specifications
Maximum electrical power consumption	1.5 W
Connectors	Duplex LC (Lucent connector)
Cabling	<ul style="list-style-type: none"> • 62.5 μm MMF optic cable • 50 μm MMF optic cable
Distance	<ul style="list-style-type: none"> • Up to 2 km using 500 MHz-km MMF optic cable
Wavelength	1310 nm
Link optical power budget	10 dB
Transmitter characteristics	
Maximum launch power	- 14 dBm
Minimum launch power	- 23.5 to -20 dBm
Receiver characteristics	
Receiver sensitivity	- 33.5 dBm
Maximum input power	—

T1 SFP specifications

The T1 SFP provides full-duplex Fast Ethernet to T1 connectivity. The part number for this model is AA1419075-E6.

ATTENTION

The switch displays the interface speed of the T1/E1 SFP as a 100 Mb/s connection even though the interface is operating at the appropriate WAN speed. The system uses this value for STP path cost and MLT utilization.

ATTENTION

Nortel recommends that you enable egress traffic shaping on the port to 1.544 Mbps when using the T1 SFP to guarantee appropriate Quality of Service and traffic prioritization.

The following table describes the T1 SFP specifications.

Table 3
Fast Ethernet to T1 remote bridge specifications

Parameter	Specifications
Maximum power consumption	1 W
Dimensions	Height: 13.8 mm (0.54 in) Width: 15.8 mm (0.62 in) Depth: 75.9 mm (2.99 in)
Standards	Compliant with G.703, G.775, G.823, T1.403, IEEE 802.3
Connectors	RJ-48C
Cabling	CAT5 with RJ-48C pin connection
Distance	Up to 2874 m over 22 AWG cable. You can reduce the distance when you use common 24 AWG UTP CAT5/5E cable.
Line code	Binary 8 Zero Substitution (B8ZS) or Alternate Mark Inversion (AMI)

The T1 SFP uses an RJ-48C connector (see the following figure), which is similar to an RJ-45 connection, but with different pinouts.

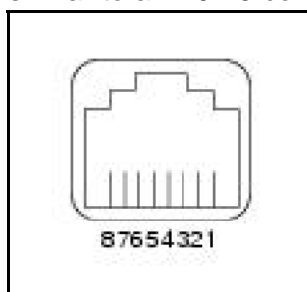

The following table describes the RJ-48C pinouts.

Table 4
RJ-48C pinouts

Pin	Description
1	Receive ring
2	Receive tip
3	Receive shield
4	Transmit ring
5	Transmit tip

Table 4
RJ-48C pinouts (cont'd.)

Pin	Description
6	Transmit shield
7	Not used
8	Not used

The T1 equipment at the far end of the T1 connection must also use an RJ-48C jack. After you determine the pinout of the RJ-48C jack at the far end, determine if you need a straight-through or crossover cable. You can use an off-the-shelf straight-through cable to directly connect the T1 SFP module and the far-end T1 equipment if the far end has the pinout shown in the following table.

Table 5
RJ-48C pinouts (opposite Tx and Rx connection)

Pin	Description
1	Transmit (Tx) ring
2	Transmit tip
3	Transmit shield
4	Receive (Rx) ring
5	Receive tip
6	Receive shield
7	Not used
8	Not used

If the far end connection does not match the connections shown in this table ([Table 5 "RJ-48C pinouts \(opposite Tx and Rx connection\)"](#) (page 33)), then you must use a crossover cable. The following table shows the crossover connections.

Table 6
RJ-48C crossover cable connections

Terminal A		Terminal B	
Pin	Description	Pin	Description
1	Receive ring	1	Transmit ring
2	Receive tip	2	Transmit tip
3	Receive shield	3	Transmit shield
4	Transmit ring	4	Receive ring
5	Transmit tip	5	Receive tip
6	Transmit shield	6	Receive shield

Table 6
RJ-48C crossover cable connections (cont'd.)

Terminal A		Terminal B	
Pin	Description	Pin	Description
7	Not used	7	Not used
8	Not used	8	Not used

You can use a short crossover cable with a straight-through cable adapter to connect to a straight-through cable. Do this to convert a straight-through cable to a crossover cable.

T1 SFP—default settings

The Ethernet Routing Switch 5000 Series switches automatically configure the following T1 SFP parameters after the system powers up:

- Transmit Line Build Out (TLBO): set according to cable length.
- Framed or Unframed: Insert framing word into the frame (1 bit for each T1 frame) or do not insert framing word into the frame.
- Line code: Binary 8 Zero Substitution (B8ZS) or Alternate Mark Inversion (AMI).
- Clock: Use Rx clock or internal clock for Tx clock (Nortel recommends internal clock for Tx clock).
- Framing: D4 or Extended Super Frame (ESF), depends on the framing word required by the T1 equipment at the far end.

Table 7
T1 SFP—default parameters

Parameter	Default setting
TLBO	0 (0 ft–133 ft)
Framed or unframed	1 (framed)
Line code	0 (B8ZS)
Tx clock source	1 (Tx clock)
Framing	1 (ESF)
Rx sensitivity	1 (limited long haul)
Yellow alarm	0 (normal operation)
Fault propagation	0 (normal operation)
Tx disabled behavior	2 (Alarm Indications Signal—AIS)
Transmit AIS	0 (normal operation)

ATTENTION

You must configure the T1 SFP module to match the parameters of the T1 equipment at the far end. If you must change the parameters, contact Nortel Technical Support.

1000BASE-T SFP specifications

The 1000BASE-T SFP provides gigabit Ethernet connectivity using a single eight-pin RJ-45 connector. The 1000BASE-T SFP only operates at 1 gigabit per second (1 Gb/s) and does not support 100BASE-T or 10BASE-T interfaces. The part number for this model is AA1419043-E6.

ATTENTION

Nortel recommends setting all 1000BaseT ports to auto-negotiate in accordance with the IEEE 802.3ab standard. By default, SFPs inserted into certain product-specific modules are set for autonegotiation = True.

The maximum current requirement of the SFP is 375 milliamperes (mA) at 5 volts (V).

The following table describes the 1000BASE-T SFP specifications.

Table 8
IEEE 802.3z 1000BASE-T SFP specifications

Parameter	Specifications
Standards	IEEE 802.3z, IEEE 802.3ab
Connectors	RJ-45
Cabling	CAT5E or better UTP
Distance	Up to 100 m

1000BASE-SX (LC) SFP specifications

The 1000BASE-SX SFP provides 1000BASE-SX gigabit Ethernet connectivity at 850 nm using multimode optical fiber. This SFP supports full-duplex operation only. The part number for this model is AA1419013-E5.

The following table describes standards, connectors, cabling, and distance for the 1000BASE-SX SFP.

Table 9
IEEE 802.3z 1000BASE-SX (LC) SFP specifications

Parameter	Specifications
Connectors	Duplex LC

Parameter	Specifications
Cabling	<ul style="list-style-type: none"> 62.5 μm MMF optic cable 50 μm MMF optic cable
Distance	<ul style="list-style-type: none"> up to 275 m using 62.5 μm MMF optic cable up to 550 m using 50 μm MMF optic cable
Wavelength	850 nanometers (nm)
Link optical power budget	7.0 deciBels (dB)
Transmitter characteristics	
Launch power	-10 to -4.0 deciBels referenced to 1 milliwatt (dBm)
Receiver characteristics	
Receiver sensitivity	-17 dBm
Maximum input power	0 dBm

1000BASE-SX (MT-RJ) SFP specifications

The 1000BASE-SX (MT-RJ type) SFP provides gigabit Ethernet connectivity using MT-RJ multimode fiber connectors. The following table describes standards, connectors, cabling, and distance for the 1000BASE-SX (MT-RJ type) SFP. The part number for this model is AA1419014-E5.

Table 10
IEEE 802.3z 1000BASE-SX (MT-RJ) SFP specifications

Parameter	Specifications
Connectors	Duplex MT-RJ
Cabling	<ul style="list-style-type: none"> 62.5 μm MMF optic cable 50 μm MMF optic cable
Distance	<ul style="list-style-type: none"> up to 275 m using 62.5 μm MMF optic cable up to 550 m using 50 μm MMF optic cable
Wavelength	850 nm
Link optical power budget	7.0 dB
Transmitter characteristics	
Launch power	- 10 to - 4.0 dBm
Receiver characteristics	
Receiver sensitivity	- 17 dBm
Maximum input power	0 dBm

1000BASE-LX SFP specifications

The 1000BASE-LX SFP provides 1000BASE-LX gigabit Ethernet connectivity at 1310 nanometers (nm) using single mode or multimode optical fiber. The 1000BASE-LX SFP supports full-duplex operation only. The part number for this model is AA1419015-E5.

The following table describes standards, connectors, cabling, and distance for the 1000BASE-LX SFP.

Table 11
IEEE 802.3z 1000BASE-LX SFP specifications

Parameter	Specifications
Connectors	Duplex LC
Cabling	<ul style="list-style-type: none"> • 50 micrometer (μm) multimode fiber (MMF) • 62.5 μm multimode fiber • 9 μm single mode fiber (SMF)
Distance	<ul style="list-style-type: none"> • Up to 550 meters (m) using MMF • Up to 10 kilometers (km) using SMF
Wavelength	1310 nm
Link optical power budget	10.5 dB
Transmitter characteristics	
Launch power	– 9.5 to – 3.0 dBm
Receiver characteristics	
Receiver sensitivity	– 20 dBm
Maximum input power	– 3.0 dBm

1000BASE-XD CWDM SFP specifications

The 1000BASE-XD SFPs provides CWDM gigabit Ethernet connectivity using single mode fiber. These SFPs support full-duplex operation only. The part numbers of the 40 km models range from AA1419025-E5 to AA1419032-E5.

ATTENTION

For the 40 km CWDM SFPs, a minimum attenuation of 4 dB must be present between the transmitter and receiver. To avoid receiver saturation, you must insert a minimum attenuation of 4 dB when you test the CWDM SFP in loopback mode, or use short runs of fiber with no intermediate CWDM OADM or CWDM OMUX.

Table 12
1000BASE-XD CWDM (40 km) SFP specifications

Parameter	Specifications
Connectors	Duplex LC
Cabling	SMF, 9 μ m
Data rate	1.0 Gb/s
Line rate (8B/10B code)	1.25 Gb/s
Operating temperature range	0 to 60C
Link optical power budget	17 dB
Transmitter characteristics	
Launch power	– 4.0 to 1.0 dBm
Receiver characteristics	
Receiver sensitivity	– 21 dBm
Maximum input power	– 3.0 dBm

1000BASE-ZX CWDM SFP specifications

The 1000BASE-ZX SFPs provides CWDM gigabit Ethernet connectivity using single mode fiber. These SFPs support full-duplex operation only. The part numbers of the 70 km models range from AA1419033-E5 to AA1419040-E5.

ATTENTION

For the 70 km CWDM SFPs, a minimum attenuation of 10 dB must be present between the transmitter and receiver.

Table 13
1000BASE-ZX CWDM (70 km) SFP specifications

Parameter	Specifications
Connectors	Duplex LC
Cabling	SMF, 9 μ m
Data rate	1.0 Gb/s
Line rate (8B/10B code)	1.25 Gb/s
Operating temperature range	0 to 60C
Link optical power budget	20 dB
Transmitter characteristics	
Launch power	– 3.0 to 2.0 dBm
Receiver characteristics	
Receiver sensitivity	– 23 dBm
Maximum input power	– 3.0 dBm

1000BASE-SX DDI SFP specifications

The following table describes the 1000BASE-SX DDI SFP, which has a reach of up to 550 m using 50 μm MMF, and of 275 m using 62.5 μm MMF. This SFP operates at 850 nm. The part number of this SFP is AA1419048-E6.

Table 14
1000BASE-SX SFP DDI (550 m) specifications

Parameter	Specifications
Maximum electrical power consumption	1 watt (W)
Connector	Duplex LC
Cabling	MMF
Data rate	1.0 Gb/s
Line rate (8B/10B code)	1.25 Gb/s
Link optical power budget	7.5 dB
Transmitter characteristics	
Launch power	- 9.5 to -4.0 dBm
Receiver characteristics	
Receiver sensitivity	- 17 dBm
Maximum receiver power	0 dBm

1000BASE-LX DDI SFP specifications

This SFP can attain a reach of up to 10 km and operates at 1310 nm. The part number of this SFP is AA1419049-E6.

Table 15
1000BASE-LX DDI SFP specifications

Parameter	Specifications
Maximum electrical power consumption	1.0 watt (W)
Connectors	Duplex LC
Cabling	SMF, 9 μm
Data rate	1.0 Gb/s
Line rate (8B/10B code)	1.25 Gb/s
Link optical power budget	9.5 dB
Transmitter characteristics	
Launch power	- 9.5 to -3.0 dBm
Receiver characteristics	

Parameter	Specifications
Receiver sensitivity	– 19.0 dBm
Maximum receiver power	– 3.0 dBm

1000BASE-XD DDI 1310 nm SFP specifications

The following table describes the 1000BASE-XD DDI SFP. This SFP operates at 1310 nm and has a reach of up to 40 km. The part number is AA1419050-E6.

Table 16
1000BASE-XD DDI 1310 nm SFP specifications

Parameter	Specifications
Maximum electrical power consumption	1.0 W
Connectors	Duplex LC
Cabling	SMF, 9 μ m
Data rate	1.0 Gb/s
Line rate (8B/10B) code	1.25 Gb/s
Link optical power budget	18 dB
Transmitter characteristics	
Launch power	– 4.5 to 0 dBm
Receiver characteristics	
Receiver sensitivity	– 22.5 dBm
Maximum receiver power	0 dBm

1000BASE-XD DDI 1550 nm SFP specifications

The following table describes the 1000BASE-XD DDI SFP. This SFP operates at 1550 nm and has a reach of up to 40 km. The part number is AA1419051-E6.

	<p>CAUTION Risk of equipment damage</p> <p>To prevent damage to the optical receiver, ensure that at least 3 dB of attenuation is present between the transmit and receive ports.</p>
---	---

Table 17
1000BASE-XD DDI 1550 nm SFP specifications

Parameter	Specification
Maximum electrical power consumption	1.0 W
Connectors	Duplex LC

Parameter	Specification
Cabling	SMF, 9 μ m
Data rate	1.0 Gb/s
Line rate (8B/10B code)	1.25 Gb/s
Link optical power budget	22 dB
Maximum dispersion power penalty	2 dB at 40 km
Transmitter characteristics	
Launch power	- 2.0 to 3.0 dBm
Receiver characteristics	
Receiver sensitivity	- 24 dBm
Maximum receiver power	0 dBm

1000BASE-ZX DDI SFP specifications

The following table describes the 1000BASE-ZX DDI SFP. This SFP operates at 1550 nm and has a reach of up to 70 km. The part number is AA1419052-E6.

	<p>CAUTION Risk of equipment damage</p> <p>To prevent damage to the optical receiver, ensure that at least 5 dB of attenuation is present between the transmit and receive ports.</p>
--	--

Table 18
1000BASE-ZX DDI 1550 nm SFP specifications

Parameter	Specifications
Maximum electrical power consumption	1.0 W
Connectors	Duplex LC
Cabling	SMF, 9 μ m
Data rate	1.0 Gb/s
Line rate (8B/10B code)	1.25 Gb/s
Link optical power budget	24 dB
Maximum dispersion power penalty	2 dB at 70 km
Transmitter characteristics	
Launch power	0 to 5 dBm
Receiver characteristics	
Receiver sensitivity	- 24 dBm
Maximum receiver power	- 0 dBm

1000BASE-XD DDI CWDM SFP specifications

The following table describes specifications for 1000BASE-XD DDI CWDM SFPs numbered AA1419053-E6 to AA1419060-E6.

	<p>CAUTION Risk of equipment damage</p> <p>To prevent damage to the optical receiver, ensure that at least 4 dB of attenuation is present between the transmit and receive ports.</p>
---	--

Table 19
1000BASE-XD CWDM SFP DDI (40 km) specifications

Parameter	Specifications
Maximum electrical power consumption	1.0 W
Connectors	Duplex LC
Cabling	SMF, 9 µm
Data rate	1.0 Gb/s
Line rate (8B/10B code)	1.25 Gb/s
Link optical power budget	17 dB
Maximum dispersion power penalty	1 dB at 40 km
Transmitter characteristics	
Launch power	– 4.0 to 1.0 dBm
Receiver characteristics	
Receiver sensitivity	– 21 dBm
Maximum receiver power	– 3.0 dBm

1000BASE-ZX DDI CWDM SFP specifications

The following table describes specifications for CWDM SFPs numbered AA1419061-E6 to AA1419068-E6.

	<p>CAUTION Risk of equipment damage</p> <p>To prevent damage to the optical receiver, ensure that at least 8 dB of attenuation is present between the transmit and receive ports.</p>
---	--

Table 20
1000BASE-ZX CWDM SFP DDI (70 km) specifications

Parameter	Specifications
Maximum electrical power consumption	1.0 W
Connectors	Duplex LC

Parameter	Specifications
Cabling	SMF, 9 μ m
Data rate	1.0 Gb/s
Line rate (8B/10B code)	1.25 Gb/s
Link optical power budget	24 dB
Maximum dispersion power penalty	2 dB at 70 km
Transmitter characteristics	
Launch power	0 to 5.0 dBm
Receiver characteristics	
Receiver sensitivity	- 24 dBm
Maximum receiver power	- 3.0 dBm

1000BASE-BX10 DDI SFP specifications

The 1000BASE-BX bidirectional SFPs (part numbers AA1419069-E6 and AA1419070-E6) provide gigabit Ethernet connectivity over a single fiber.

The following figure shows an example of a 1000BASE-BX10 SFP pair. The appearance of the connector can vary in shape and latch color.

Figure 2
1000BASE-BX

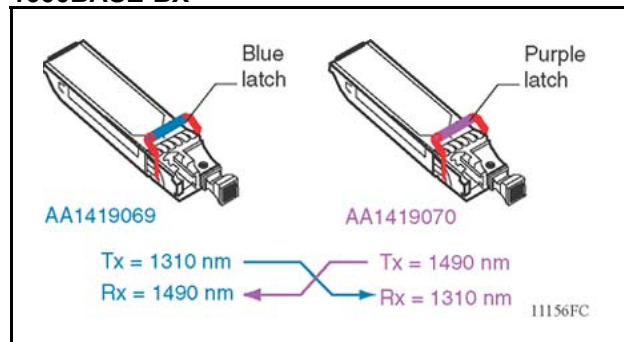

As shown in the previous figure, the transmit (Tx) and receive (Rx) paths share the same fiber by using two different wavelengths. One model transmits at 1310 nm and receives at 1490 nm, while the mating model transmits at 1490 nm and receives at 1310 nm. You can only connect a mating pair.

You can use 1000BASE-BX SFPs to double the number of your fiber links. For example, if you install 20 fiber pairs with 20 conventional ports connected, you can use 1000BASE-BX SFPs to expand to 40 ports, using the same fiber.

The long wavelength optical transceivers used in these models provide variable distance ranges using single mode fiber optic cabling.

The following table describes standards, connectors, cabling, and distances for the 1000BASE-BX SFP.

Table 21
IEEE 802.3ah 1000BASE-BX10 SFP specifications

Parameter	Specifications
Connectors	Single-fiber LC
Data rate	1.0 Gb/s
Line rate (8B/10B code)	1.25 Gb/s
Distance	Up to 10 km
Wavelength	1310 nm and 1490 nm
Link optical power budget	11.0 dB
Maximum transmitter and dispersion power penalty	3.3 dB
Transmitter characteristics	
Maximum launch power	– 3.0 dBm
Minimum launch power	– 9.0 dBm
Receiver characteristics	
Maximum receiver sensitivity	– 19.5 dBm
Maximum input power (maximum average receive power)	– 3.0 dBm

1000BASE-BX40 DDI SFP specifications

The 1000BASE-BX bidirectional SFPs (part numbers AA1419076-E6 and AA1419077-E6) provide gigabit Ethernet connectivity over a single fiber.

The transmit and receive paths share the same fiber by using two different wavelengths. One model transmits at 1310 nm and receives at 1490 nm, while the mating model transmits at 1490 nm and receives at 1310 nm. You can only connect a mating pair.

You can use 1000BASE-BX SFPs to double the number of your fiber links. For example, if you have 20 installed fiber pairs with 20 conventional ports connected, you can use 1000BASE-BX SFPs to expand to 40 ports, using the same fiber.

The long wavelength optical transceivers used in these models provide variable distance ranges using single mode fiber optic cabling.

The 1000BASE-BX SFPs (part numbers AA1419076-E6 and AA1419077-E6) can attain a reach of up to 40 km.

The following table describes standards, connectors, cabling, and distances for the 1000BASE-BX SFP.

	<p>CAUTION Risk of equipment damage Connect 1000BASE-BX SFP AA1419076-E6 to 1000BASE-BX SFP AA1419077-E6 using a single mode fiber with at least 6 dB of attenuation. Damage can result if insufficient attenuation is provided or if the same 1000-BASE-BX SFPs are connected.</p>
---	---

Table 22
IEEE 802.3ah 1000BASE-BX40 SFP specifications

Parameter	Specifications
Connectors	Single-fiber LC
Data rate	1.0 Gb/s
Line rate (8B/10B code)	1.25 Gb/s
Distance	Up to 40 km with SMF
Wavelength	1310 nm and 1490 nm
Link optical power budget	20.0 dB
Maximum transmitter and dispersion power penalty	3.3 dB
Transmitter characteristics	
Maximum launch power	3.0 dBm
Minimum launch power	– 3.0 dBm
Receiver characteristics	
Maximum receiver sensitivity	– 23 dBm
Maximum input power (maximum average receive power)	– 3.0 dBm

1000BASE-EX DDI SFP specifications

The following table describes the 1000BASE-EX DDI SFP. This SFP operates at 1550 nm and has a reach of up to 120 km. The part number of this SFP is AA1419071-E6.

**CAUTION****Risk of equipment damage**

To prevent damage to the optical receiver, ensure that at least 14 dB of attenuation is present between the transmit and receive ports.

To attain the BER of 10^{-12} , the minimum attenuation between the transmit and receive ports is 15 dB.

Table 23
1000BASE-EX DDI SFP specifications

Parameter	Specifications
Maximum electrical power consumption	1.2 W
Connectors	Duplex LC
Cabling	SMF, 9 μ m
Data rate	1.0 Gb/s
Line rate (8B/10B code)	1.25 Gb/s
Link optical power budget	30 dB
Maximum dispersion power penalty	2.0 dB at 120 km
Transmitter characteristics	
Launch power	0 to 5.0 dBm
Receiver characteristics	
Receiver sensitivity	- 30 dBm
Maximum receiver power	- 9.0 dBm

10 Gigabit small form factor pluggable transceivers

This section describes how to install and remove 10 gigabit small form factor pluggable (XFP) transceivers, and lists some technical specifications for the supported XFP models.

ATTENTION

Nortel recommends that you only use Nortel-qualified XFPs. If you do choose to use other vendor XFPs, be aware that Nortel does not support the use of other XFPs.

Navigation

- [“Selecting an XFP” \(page 47\)](#)
- [“Installing an XFP” \(page 49\)](#)
- [“Removing an XFP” \(page 51\)](#)
- [“XFP specifications” \(page 53\)](#)

Selecting an XFP

Use an XFP transceiver to interface a device motherboard to a fiber optic cable. Select the appropriate transceiver to provide the required reach.

Procedure steps

Step	Action
1	Determine the required reach. Depending on the product, XFPs are available for cable distances of up to 300 meters (m), 10 kilometers (km), 40 km, and 80 km.
2	Determine wavelength restrictions or requirements.

- 3 Use the following job aids to determine the appropriate XFP for your application.

--End--

Job aid

XFPs are hot-swappable input and output enhancement components designed for use with Nortel products to allow 10 gigabit Ethernet ports to link with other 10 gigabit Ethernet ports.

All Nortel XFPs use Lucent connectors (LC) to provide precision keying and low interface losses.

The following table lists and describes the Nortel XFP models. For more information about specifications for these XFPs, see [“XFP specifications”](#) (page 53). Not all products support all XFPs.

Model number and product number	Wavelength (nanometers [nm])	Cable	Size (micrometer [μm])	Bandwidth (megaHertz times km [MHz*km])	Maximum distance
10GBASE-SR AA1403005-E5	850	MMF	62.5	160	22 m
			62.5	200	33 m
			62.5	500	66 m
			50	500	82 m
			50	2000	300 m
10GBASE-LR/LW AA1403001-E5	1310	SMF (ITU G.652)	N/A	N/A	10 km
10GBASE-ER/EW AA1403003-E5	1550	SMF (ITU G.652)	N/A	N/A	40 km
10GBASE-LRM AA1403007-E6	1300	MMF	62.5 (FDDI grade)	500	220 m
			62.5 (ISO/IEC OM1)	500	
			50 (ISO/IEC OM2)	500	
			50 (ISO/IEC OM3)	500 (includes laser launch bandwidth)	

Model number and product number	Wavelength (nanometers [nm])	Cable	Size (micrometer [μm])	Bandwidth (megaHertz times km [MHz*km])	Maximum distance
			50	400	100 m
10GBASE-ZR/ZW AA1403006-E5	1550	SMF (ITU G.652)	N/A	N/A	80 km

Installing an XFP

Install an XFP to provide a 10 gigabit Ethernet interface between the switch and other network devices.

Installing an XFP takes approximately three minutes.

Prerequisites

- Verify that the XFP is the correct model for your network configuration.
- Before you install the optical connector, ensure it is clean.



WARNING

Risk of eye injury by laser

Fiber optic equipment can emit laser or infrared light that can injure your eyes. Never look into an optical fiber or connector port. Always assume that fiber optic cables are connected to a light source.



CAUTION

Risk of equipment damage

To prevent damage from electrostatic discharge, always wear an antistatic wrist strap connected to an ESD jack.



CAUTION

Risk of equipment damage

Only trained personnel can install this product.

Procedure steps



CAUTION

Risk of equipment damage

XFPs are keyed to prevent incorrect insertion. If the XFP resists pressure, do not force it; turn it over, and reinsert it.

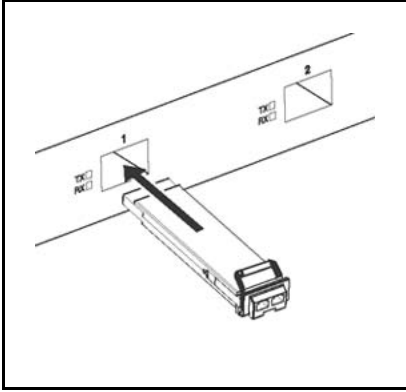
Step	Action
1	Remove the XFP from its protective packaging.
2	Grasp the XFP between your thumb and forefinger.
3	Insert the XFP into the XFP slot on the module. Apply a light pressure to the XFP until the device clicks and locks into position in the module.
	
4	Remove the dust cover from the XFP optical bores and insert the fiber optic cable.

--End--

Job aid

Depending on the transceiver manufacturer, your XFP transceiver can have various types of locking and extractor mechanisms.

The following figure shows a typical bail-type mechanism used on XFP transceivers. Pull the bail down to release the device.

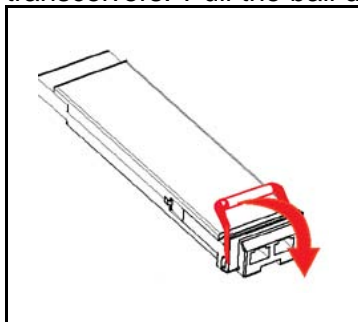

Removing an XFP

Remove an XFP to replace it or to commission it elsewhere.



WARNING

Risk of eye injury by laser

Fiber optic equipment can emit laser or infrared light that can injure your eyes. Never look into an optical fiber or connector port. Always assume that fiber optic cables are connected to a light source.



CAUTION

Risk of equipment damage

To prevent damage from electrostatic discharge, always wear an antistatic wrist strap connected to an ESD jack.

Procedure steps

Step	Action
1	Disconnect the network fiber cable from the XFP connector.
2	Affix a dust cover over the optical connector.
3	Pull the bail mechanism on the XFP to release the XFP.
4	Slide the XFP out of the module XFP slot. If the XFP does not slide easily from the module slot, use a gentle side-to-side rocking motion while firmly pulling the XFP from the slot.
5	Replace the port dust cover or EMI plug in the module.
6	Store the XFP in a safe place until needed.

ATTENTION

If you discard the XFP, be sure to dispose of it according to all national laws and regulations.

--End--

XFP specifications

This section provides technical specifications for the supported 10 gigabit SFP (XFP) models. Use these specifications to aid in network design.

The specifications in this section are a subset of the IEEE 802.3ae and 802.3aq specifications. For more information, see these standards documents. All Nortel XFPs meet or exceed these standards.

ATTENTION

Nortel recommends that you only use Nortel-qualified XFPs. If you do choose to use other vendor XFPs, be aware that Nortel does not support the use of other XFPs.

Navigation

- [“XFP labels” \(page 53\)](#)
- [“General XFP specifications” \(page 54\)](#)
- [“10GBASE-SR XFP specifications” \(page 54\)](#)
- [“10GBASE-LRM XFP specifications” \(page 56\)](#)
- [“10GBASE-LR/LW XFP specifications” \(page 58\)](#)
- [“10GBASE-ER/EW XFP specifications” \(page 60\)](#)
- [“10GBASE-ZR/ZW XFP specifications” \(page 61\)](#)

XFP labels

As shown in the following figure, the Nortel label on a typical XFP contains a Nortel serial number, a bar code, a manufacturer code, an interface type, and a part number.

Figure 3
XFP label

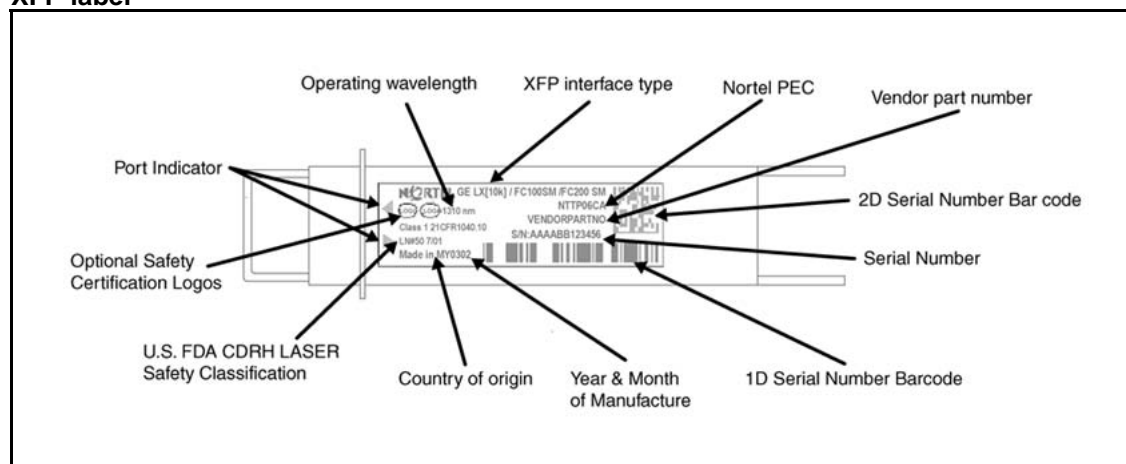

General XFP specifications

The following table describes general XFP specifications.

Table 24
General XFP specifications

Parameter	Specifications
Dimensions (H x W x D)	0.49 x 0.72 x 2.79 inches (in.) 12.5 x 18.35 x 71.1 millimeters (mm)
Connectors	Duplex LC ultra physical contact (UPC)
Storage temperature	- 40 to 85C
Operating temperature	0 to 70C

10GBASE-SR XFP specifications

The 10GBASE-SR SFP provides 10 GbE service at 850 nm.

The following table lists the specifications for the 10GBASE-SR XFP. The part number of this XFP is AA1403005-E5.

For more information about the 10GBASE-SR XFP, including test and measurement information, see the IEEE 802.3ae standard.

The 10GBASE-SR XFP is supported by the Ethernet Routing Switch 5530 (not by the 5510 or 5520), and by the Ethernet Routing Switch 5600 Series.

**CAUTION****Risk of equipment damage**

To prevent damage to the optical receiver, ensure that at least 1 dB of attenuation is present between the transmit and receive ports.

Table 25
IEEE 802.3ae 10GBASE-SR XFP specifications

Parameter	Specifications
Data rate	10.0 Gb/s
Line rate (64B/66B code)	10.3125 gigabits per second (Gb/s) \pm 100 parts per million (ppm)
Mean Time Between Failures (MTBF)	675 000 hours
Center wavelength range	840 to 860 nanometers (nm), nominal 850 nm
Distance	Using 62.5 μ m MMF optic cable: <ul style="list-style-type: none"> • 160 MHz-km fiber: 2 to 26 m • 200 MHz-km fiber: 2 to 33 m Using 50 μ m MMF optic cable: <ul style="list-style-type: none"> • 400 MHz-km fiber: 2 to 66 m • 500 MHz-km fiber: 2 to 82 m • 2000 MHz-km fiber: 2 to 300 m
Link optical power budget	7.3 dB
Maximum transmitter and dispersion penalty	3.9 dB at 300 m
Transmitter characteristics	
Root-mean-square spectral width	0.05 to 0.40 nm
Launch power	- 7.3 to - 1.0 decibels referenced to 1 milliwatt (dBm)
Maximum average launch power of OFF transmitter	- 30 dBm
Minimum extinction ratio	3.0 dB
Maximum relative intensity noise ₁₂ OMA	- 128 dB per Hertz (dB/Hz)
Maximum optical return loss tolerance	- 12 dB
Receiver characteristics	
Average receive power for BER 10 ⁻¹²	- 9.9 to - 1.0 dBm
Maximum average receive power for damage	0 dBm
Maximum receiver sensitivity in OMA	- 11.1 dBm

Table 25
IEEE 802.3ae 10GBASE-SR XFP specifications (cont'd.)

Parameter	Specifications
Maximum receiver reflectance	– 12 dB
Stressed receiver sensitivity in OMA	– 7.5 dBm
Receiver electrical 3 dB upper cutoff frequency	12.3 gigaHertz (GHz)

The stressed sensitivity values are for system level BER measurements, which include the effects of clock and data recovery (CDR) circuits. Nortel recommends that you allocate at least 0.4 dB additional margin if you make component level measurements without the effect of CDR circuits.

10GBASE-LRM XFP specifications

The 10GBASE-LRM XFP provides 10 GbE service at a wavelength of 1310 nm. This XFP can attain a reach of up to 220 m on 62.5 μm multimode fiber. This XFP provides built-in electronic dispersion compensation.

The following table lists the transmitter and receiver specifications for the 10GBASE-LRM XFP. These parameters meet the IEEE 802.3aq-2006 standard. The part number of this XFP is AA1403007-E6.

In this table, the OMA, average launch power, and peak power specifications apply at TP2, after patch cord loss is accounted for.

Table 26
IEEE 802.3aq 10GBASE-LRM XFP specifications

Parameter	Specifications
Data rate	10.0 Gb/s
Line rate (64B/66B code)	10.3125 Gb/s \pm 100 ppm
Center wavelength range	1260 to 1355 nm; 1310 nm nominal
Distance	Up to 220 m, for more information, see Table 27 "10GBASE-LRM channel insertion loss and range" (page 57)
Link optical power budget	1.7 to 1.9 dB, for more information, see Table 27 "10GBASE-LRM channel insertion loss and range" (page 57)
Maximum transmitter waveform and dispersion penalty (TWDP)	4.7 dB
Transmitter characteristics	
Average launch power	– 6.5 to 0.5 dBm
Peak launch power	3 dBm

Parameter	Specifications
Root-mean-square spectral width	2.4 to 4 nm
Launch power in OMA	– 4.5 to 1.5 dBm
Maximum average launch power of OFF transmitter	– 30 dBm
Minimum extinction ratio	3.5 dB
Maximum relative intensity noise at OMA— RIN_{12OMA}	– 128 dB/Hz
Optical return loss tolerance (minimum)	– 20 dB
Receiver characteristics	
Maximum receive average power for damage	1.5 dBm
Receiver reflectance (maximum)	– 12 dB

For more information about the conditions used for the stressed receiver tests, and other information, see the IEEE 802.3aq standard.

The following table (from IEEE 802.3aq) describes the maximum channel insertion loss. The channel insertion loss includes both attenuation and connector loss (1.5 dB); therefore the maximum fiber attenuation is 0.2 to 0.4 dB.

Table 27
10GBASE-LRM channel insertion loss and range

Fiber type (core diameter and OFL bandwidth)	Range	Maximum channel insertion loss
62.5 μ m (FDDI grade) <ul style="list-style-type: none"> • 160 MHz-km at 850 nm • 500 MHz-km at 1300 nm 	Up to 220 m	1.9 dB
62.5 μ m (ISO/IEC OM1) <ul style="list-style-type: none"> • 200 MHz-km at 850 nm • 500 MHz-km at 1300 nm 	Up to 220 m	1.9 dB
50 μ m (ISO/IEC OM2) <ul style="list-style-type: none"> • 500 MHz-km at 850 nm • 500 MHz-km at 1300 nm 	Up to 220 m	1.9 dB

Fiber type (core diameter and OFL bandwidth)	Range	Maximum channel insertion loss
50 μm <ul style="list-style-type: none"> 400 MHz-km at 850 nm 400 MHz-km at 1300 nm 	Up to 100 m	1.7 dB
50 μm (ISO/IEC OM3) <ul style="list-style-type: none"> 1500 MHz-km at 850 nm (includes laser launch bandwidth) 500 MHz-km at 1300 nm (includes laser launch bandwidth) 	Up to 220 m	1.9 dB

In the table, FDDI denotes Fiber Distributed Data Interface, ISO denotes International Standards Organization, IEC denotes International Electrotechnical Commission, and OFL denotes Over Filled Launch.

The following table is based on the 802.3aq standard and specifies the measurement conditions for each fiber type.

Table 28
Launch conditions for each fiber type

Parameter	Minimum encircled flux	Notes
Optical launch for OM1 and FDDI-grade fiber	<ul style="list-style-type: none"> 30% within 5 μm radius 81% within 11 μm radius 	Uses 62.5 μm mode conditioning patch cord
Optical launch for OM2 and 50 μm 400/400 fiber	<ul style="list-style-type: none"> 30% within 5 μm radius 81% within 11 μm radius 	Uses 50 μm mode conditioning patch cord
Optical launch for OM3 and 50 μm fiber	<ul style="list-style-type: none"> 30% within 5 μm radius 81% within 11 μm radius 	—

10GBASE-LR/LW XFP specifications

The 10GBASE-LX XFP provides 10 GbE or OC-192 service at a nominal wavelength of 1310 nm. This XFP can attain link lengths of up to 10 km.

The following table lists the transmitter and receiver specifications for the 10GBASE-LR/LW XFP. The part number of this XFP is AA1403001-E5.

For more information about the 10GBASE-LX XFP, including test and measurement information, see the IEEE 802.3ae standard.

Table 29
IEEE 802.3ae 10GBASE-LR/LW XFP specifications

Parameter	Specifications
MTBF	675 000 hours

Table 29
IEEE 802.3ae 10GBASE-LR/LW XFP specifications (cont'd.)

Parameter	Specifications
Center wavelength range	1260 to 1355 nm; 1310 nm nominal
Distance	Up to 10 km
Link optical power budget	9.4 dB
Maximum transmitter and dispersion penalty	3.2 dB at 10 km
Transmitter characteristics	
Line rate (nominal)	10GBASE-LR 10.3125 Gb/s \pm 100 ppm (10 GbE) 10GBASE-LW 9.95328 Gb/s \pm 20 ppm (OC-192)
Average launch power	– 8.2 to 0.5 dBm
Minimum side mode suppression ratio	30 dB
Minimum launch power in OMA minus transmission and dispersion penalty (TDP)	– 6.2 dBm
Minimum optical modulation amplitude	– 5.2 dBm
Maximum average launch power of OFF transmitter ^c	– 30 dBm
Minimum extinction ratio	3.5 dB
RIN ₁₂ OMA (maximum)	– 128 dB/Hz
Maximum optical return loss tolerance	– 12 dB
Maximum transmitter reflectance	– 12 dB
Receiver characteristics	
Line rate (nominal)	10GBASE-LR 10.3125 Gb/s \pm 100 ppm (10 GbE) 10GBASE-LW 9.95328 Gb/s \pm 100 ppm (OC-192)
Average receive power for BER 10 ⁻¹²	– 14.4 dBm to 0.5 dBm
Maximum average receive power for damage	1.5 dBm
Maximum receiver sensitivity in OMA	– 12.6 dBm
Maximum receiver reflectance	– 12 dB
Stressed receiver sensitivity in OMA	– 10.3 dBm
Receiver electrical 3 dB upper cutoff frequency	12.3 GHz

Examples of an OFF transmitter are as follows: no power supplied to the PDM, laser shutdown for safety conditions, activation of a PMD_global_transmit_disable or other optional transmitter shut down condition

10GBASE-ER/EW XFP specifications

The following table lists the transmitter and receiver specifications for the 10GBASE-ER/EW XFP. The reach for this XFP is up to 40 km at a wavelength of 1550 nm. The part number of this XFP is AA1403003-E5.

For more information about the 10GBASE-EX XFP, including test and measurement information and more specifications, see the IEEE 802.3ae standard.

Table 30
IEEE 802.3ae 10GBASE-ER/EW XFP specifications

Parameter	Specifications
Line rate (nominal)	10GBASE-ER 10.3125 Gb/s \pm 100 ppm (10 GbE) 10GBASE-EW 9.95328 Gb/s \pm 20 ppm (OC-192)
MTBF	675 000 hours
Center wavelength range	1530 to 1565 nm; nominal 1550 nm
Distance	Up to 40 km
Link optical power budget	15 dB
Transmitter and dispersion power penalty	3.0 dB at 40 km
Transmitter characteristics	
Launch power	-- 4.7 to 4.0 dBm
Minimum side mode suppression ratio	30 dB
Minimum launch power in OMA minus transmission and dispersion penalty (TDP)	- 2.1 dBm
Minimum optical modulation amplitude	- 1.7 dBm
Maximum average launch power of OFF transmitter	-- 30 dBm
Minimum extinction ratio	3.0 dB
Maximum RIN_{12OMA}	- 128 dB/Hz
Maximum optical return loss tolerance	- 21 dB
Receiver characteristics	
Average receive power for BER 10^{-12}	- 15.8 dBm to - 1.0 dBm
Maximum receive power for damage	4.0 dBm
Maximum receiver sensitivity in OMA	- 14.1 dBm
Maximum receiver reflectance	- 26 dB
Stressed receiver sensitivity in OMA	- 11.3 dBm
Receive electrical 3 dB upper cutoff frequency (maximum)	12.3 GHz

Examples of an OFF transmitter are as follows: no power supplied to the PDM, laser shutdown for safety conditions, activation of a PMD_global_transmit_disable or other optional transmitter shut down conditions.

10GBASE-ZR/ZW XFP specifications

The following table lists the transmit and receive specifications for the 10GBASE-ZR/ZW XFP. The reach is up to 80 km at a wavelength of 1550 nm. The part number of this XFP is AA1403006-E5.

For more information about the 10GBASE-ZX XFP, including test and measurement information and more specifications, see the IEEE 802.3ae standard.

	<p>CAUTION Risk of BER increase For proper XFP operation, ensure that at least 11 dB of attenuation is present between the transmit and receive ports.</p>
---	--

Table 31
10GBASE-ZR/ZW XFP specifications

Parameter	Specifications
Line rate (nominal)	10GBASE-ZR 10.3125 Gb/s \pm 100 ppm (10 GbE) 10GBASE-ZW 9.95328 Gb/s \pm 20 ppm (OC-192)
MTBF	675 000 hours
Distance	Up to 80 km
Link optical power budget	24 dB
Maximum transmitter and dispersion penalty	3.0 dB at 80 km (G.652 fiber)
Transmitter characteristics	
Center wavelength range	1530 to 1565 nm; nominal 1550 nm
Side mode suppression ratio (minimum)	30 dB
Average launch power	0 to 4.0 dBm
Optical modulation amplitude (minimum)	- 1.7 dBm
Average launch power of OFF transmitter (maximum)	- 30 dBm
Extinction ratio (ER)	minimum 3.5 dB end of life maximum 7.0 dB start of life
RIN ₁₂ OMA (maximum)	- 128 dB/Hz
Maximum optical return loss tolerance	- 26 dB
Maximum transmitter reflectance	- 12 dB

Parameter	Specifications
Receiver characteristics	
Wavelength range	1280 to 1575 nm. Sensitivity specified for 1530 to 1565 nm.
Signaling speed (nominal)	10GBASE-ZR 10.3125 Gb/s \pm 100 ppm (10 GbE) 10GBASE-ZW 9.95328 Gb/s \pm 100 ppm (OC-192)
Maximum average receiver sensitivity	- 24 dBm
Maximum receive power (for BER 10^{-12} and 9 dB ER)	- 7.0 dBm
Maximum average receive power for damage	5.0 dBm
Receiver reflectance (maximum)	- 27 dB
Receive electrical 3 dB upper cutoff frequency	9.3 GHz

Index

1000BASE-BX	
SFP	24
1000BASE-BX DDI	
SFP	43
1000BASE-BX10	
SFP	22
1000BASE-BX40	
SFP	22
1000BASE-EX	
SFP	22, 24
1000BASE-EX DDI	
SFP	45
1000BASE-LX	
SFP	22–24, 37
1000BASE-LX DDI	
SFP	39
1000BASE-SX	
SFP	22, 24
1000BASE-SX DDI	
SFP	39
1000BASE-SX LC	
SFP	23, 35
1000BASE-SX MT-RJ	
SFP	23, 36
1000BASE-T	
SFP	22, 24, 35
1000BASE-XD	
SFP	22–24, 37
1000BASE-XD DDI	
SFP	40, 42
1000BASE-ZX	
SFP	22–24, 38
1000BASE-ZX DDI	
SFP	41–42
100BASE-FX	
SFP	23, 31
10GBASE-ER/EW	
XFP	60
10GBASE-LR/LW	
XFP	58
10GBASE-LRM	
XFP	56
10GBASE-SR	
XFP	54
10GBASE-ZR/ZW	
XFP	61
802.3aq-2006	56
A	
AA1403001-E5	58
AA1403003-E5	60
AA1403005-E5	54
AA1403006-E5	61
AA1403007-E6	56
AA1419013-E5	23, 35
AA1419014-E5	23, 36
AA1419015-E5	23, 37
AA1419025-E5	23, 37
AA1419032-E5	23, 37
AA1419033-E5	23, 38
AA1419040-E5	23, 38
AA1419043-E6	24, 35
AA1419048-E6	24, 39
AA1419049-E6	24, 39
AA1419050-E6	24, 40
AA1419051-E6	24, 40
AA1419052-E6	24, 41
AA1419053-E6	24, 42
AA1419060-E6	24, 42
AA1419061-E6	24, 42
AA1419068-E6	24, 42
AA1419069-E6	24, 43
AA1419070-E6	24, 43
AA1419071-E6	24, 45
AA1419074-E6	23, 31

AA1419075-E6 23, 31
AA1419076-E6 24
AA1419077-E6 24

C

cable
 crossover 33
 straight-through 33
cleaning
 duplex connectors 13
 fiber optic connectors 12
 receptacles or ports 14
connector care 11
connectors
 cleaning single connectors 12

D

dispersion compensation 56
duplex connectors
 cleaning 13

E

electrostatic discharge 9

F

fiber optic cable
 cleaning connectors for 11
 precautions with 10

R

receptacles or ports
 cleaning 14
RJ-48C 32

S

safety 9
SFP
 installation 24
 label 30
 lock and extraction mechanisms 26
 physical specifications 30
 removal 27
 selection 21

T

T1

SFP 23, 31

X

XFP
 installation 49
 label 53
 lock and extraction mechanisms 50
 physical specifications 54
 removal 51
 selection 47

Nortel Ethernet Routing Switch 5000 Series

Installation — SFPs and XFPs

Release: 6.2

Publication: NN47200-302

Document revision: 03.01

Document release date: 28 June 2010

Copyright © 2007-2010 Nortel Networks. All Rights Reserved.

While the information in this document is believed to be accurate and reliable, except as otherwise expressly agreed to in writing NORTEL PROVIDES THIS DOCUMENT "AS IS" WITHOUT WARRANTY OR CONDITION OF ANY KIND, EITHER EXPRESS OR IMPLIED. The information and/or products described in this document are subject to change without notice.

Nortel, Nortel Networks, the Nortel logo, and the Globemark are trademarks of Nortel Networks.

Cletpop is a trademark of NTT-ME Corporation.

IEEE is a trademark of the Institute of Electrical and Electronics Engineers, Inc.

Lucent is a trademark of Lucent Technologies, Inc.

All other trademarks are the property of their respective owners.

To provide feedback or to report a problem in this document, go to www.nortel.com/documentfeedback

www.nortel.com

