



Installing the Avaya Virtual Services Platform 4000 VSP4850GTS Series

Release 4.0
NN46251-300
Issue 03.04
June 2014

Notice

While reasonable efforts have been made to ensure that the information in this document is complete and accurate at the time of printing, Avaya assumes no liability for any errors. Avaya reserves the right to make changes and corrections to the information in this document without the obligation to notify any person or organization of such changes.

Documentation disclaimer

"Documentation" means information published by Avaya in varying mediums which may include product information, operating instructions and performance specifications that Avaya may generally make available to users of its products and Hosted Services. Documentation does not include marketing materials. Avaya shall not be responsible for any modifications, additions, or deletions to the original published version of documentation unless such modifications, additions, or deletions were performed by Avaya. End User agrees to indemnify and hold harmless Avaya, Avaya's agents, servants and employees against all claims, lawsuits, demands and judgments arising out of, or in connection with, subsequent modifications, additions or deletions to this documentation, to the extent made by End User.

Link disclaimer

Avaya is not responsible for the contents or reliability of any linked websites referenced within this site or documentation provided by Avaya. Avaya is not responsible for the accuracy of any information, statement or content provided on these sites and does not necessarily endorse the products, services, or information described or offered within them. Avaya does not guarantee that these links will work all the time and has no control over the availability of the linked pages.

Warranty

Avaya provides a limited warranty on Avaya hardware and software. Refer to your sales agreement to establish the terms of the limited warranty. In addition, Avaya's standard warranty language, as well as information regarding support for this product while under warranty is available to Avaya customers and other parties through the Avaya Support website: <http://support.avaya.com> or such successor site as designated by Avaya. Please note that if you acquired the product(s) from an authorized Avaya Channel Partner outside of the United States and Canada, the warranty is provided to you by said Avaya Channel Partner and not by Avaya.

Licenses

THE SOFTWARE LICENSE TERMS AVAILABLE ON THE AVAYA WEBSITE, [HTTP://SUPPORT.AVAYA.COM/LICENSEINFO](http://support.avaya.com/licenseinfo) OR SUCH SUCCESSOR SITE AS DESIGNATED BY AVAYA, ARE APPLICABLE TO ANYONE WHO DOWNLOADS, USES AND/OR INSTALLS AVAYA SOFTWARE, PURCHASED FROM AVAYA INC., ANY AVAYA AFFILIATE, OR AN AVAYA CHANNEL PARTNER (AS APPLICABLE) UNDER A COMMERCIAL AGREEMENT WITH AVAYA OR AN AVAYA CHANNEL PARTNER. UNLESS OTHERWISE AGREED TO BY AVAYA IN WRITING, AVAYA DOES NOT EXTEND THIS LICENSE IF THE SOFTWARE WAS OBTAINED FROM ANYONE OTHER THAN AVAYA, AN AVAYA AFFILIATE OR AN AVAYA CHANNEL PARTNER; AVAYA RESERVES THE RIGHT TO TAKE LEGAL ACTION AGAINST YOU AND ANYONE ELSE USING OR SELLING THE SOFTWARE WITHOUT A LICENSE. BY INSTALLING, DOWNLOADING OR USING THE SOFTWARE, OR AUTHORIZING OTHERS TO DO SO, YOU, ON BEHALF OF YOURSELF AND THE ENTITY FOR WHOM YOU ARE INSTALLING, DOWNLOADING OR USING THE SOFTWARE (HEREINAFTER REFERRED TO INTERCHANGEABLY AS "YOU" AND "END USER"), AGREE TO THESE TERMS AND CONDITIONS AND CREATE A BINDING CONTRACT BETWEEN YOU AND AVAYA INC. OR THE APPLICABLE AVAYA AFFILIATE ("AVAYA").

Avaya grants you a license within the scope of the license types described below, with the exception of Heritage Nortel Software, for which the scope of the license is detailed below. Where the order documentation does not expressly identify a license type, the applicable license will be a Designated System License. The applicable number of licenses and units of capacity for which the license is granted will be one (1), unless a different number of licenses or units of capacity is specified in the documentation or other materials available to you. "Software" means Avaya's computer programs in object code, provided by Avaya or an Avaya Channel Partner, whether as stand-alone products, pre-installed, or remotely accessed on hardware products, and any upgrades, updates, bug fixes, or modified versions thereto. "Designated Processor" means a single stand-alone computing device. "Server" means a Designated Processor that hosts a software application to be accessed by multiple users. "Instance" means a single copy of the Software executing at a particular time: (i) on one physical machine; or (ii) on one deployed software virtual machine ("VM") or similar deployment.

Licence types

Designated System(s) License (DS). End User may install and use each copy or an Instance of the Software only on a number of Designated Processors up to the number indicated in the order. Avaya may require the Designated Processor(s) to be identified in the order by type, serial number, feature key, Instance, location or other specific designation, or to be provided by End User to Avaya through electronic means established by Avaya specifically for this purpose.

Heritage Nortel Software

"Heritage Nortel Software" means the software that was acquired by Avaya as part of its purchase of the Nortel Enterprise Solutions Business in December 2009. The Heritage Nortel Software currently available for license from Avaya is the software contained within the list of Heritage Nortel Products located at <http://support.avaya.com/LicenseInfo/> under the link "Heritage Nortel Products", or such successor site as designated by Avaya. For Heritage Nortel Software, Avaya grants Customer a license to use Heritage Nortel Software provided hereunder solely to the extent of the authorized activation or authorized usage level, solely for the purpose specified in the Documentation, and solely as embedded in, for execution on, or (in the event the applicable Documentation permits installation on non-Avaya equipment) for communication with Avaya equipment. Charges for Heritage Nortel Software may be based on extent of activation or use authorized as specified in an order or invoice.

Copyright

Except where expressly stated otherwise, no use should be made of materials on this site, the Documentation, Software, Hosted Service, or hardware provided by Avaya. All content on this site, the documentation, Hosted Service, and the Product provided by Avaya including the selection, arrangement and design of the content is owned either by Avaya or its licensors and is protected by copyright and other intellectual property laws including the sui generis rights relating to the protection of databases. You may not modify, copy, reproduce, republish, upload, post, transmit or distribute in any way any content, in whole or in part, including any code and software unless expressly authorized by Avaya. Unauthorized reproduction, transmission, dissemination, storage, and or use without the express written consent of Avaya can be a criminal, as well as a civil offense under the applicable law.

Third Party Components

"Third Party Components" mean certain software programs or portions thereof included in the Software or Hosted Service may contain software (including open source software) distributed under third party agreements ("Third Party Components"), which contain terms regarding the rights to use certain portions of the Software ("Third Party Terms"). As required, information regarding distributed Linux OS source code (for those Products that have distributed Linux OS source code) and identifying the copyright holders of the Third Party Components and the Third Party Terms that apply is available in the Documentation or on Avaya's website at: <http://support.avaya.com/>

[Copyright](#) or such successor site as designated by Avaya. You agree to the Third Party Terms for any such Third Party Components

Preventing Toll Fraud

“Toll Fraud” is the unauthorized use of your telecommunications system by an unauthorized party (for example, a person who is not a corporate employee, agent, subcontractor, or is not working on your company's behalf). Be aware that there can be a risk of Toll Fraud associated with your system and that, if Toll Fraud occurs, it can result in substantial additional charges for your telecommunications services.

Avaya Toll Fraud intervention

If you suspect that you are being victimized by Toll Fraud and you need technical assistance or support, call Technical Service Center Toll Fraud Intervention Hotline at +1-800-643-2353 for the United States and Canada. For additional support telephone numbers, see the Avaya Support website: <http://support.avaya.com> or such successor site as designated by Avaya. Suspected security vulnerabilities with Avaya products should be reported to Avaya by sending mail to: securityalerts@avaya.com.

Trademarks

The trademarks, logos and service marks (“Marks”) displayed in this site, the Documentation, Hosted Service(s), and Product(s) provided by Avaya are the registered or unregistered Marks of Avaya, its affiliates, or other third parties. Users are not permitted to use such Marks without prior written consent from Avaya or such third party which may own the Mark. Nothing contained in this site, the Documentation, Hosted Service(s) and Product(s) should be construed as granting, by implication, estoppel, or otherwise, any license or right in and to the Marks without the express written permission of Avaya or the applicable third party.

Avaya is a registered trademark of Avaya Inc.

All non-Avaya trademarks are the property of their respective owners. Linux® is the registered trademark of Linus Torvalds in the U.S. and other countries.

Downloading Documentation

For the most current versions of Documentation, see the Avaya Support website: <http://support.avaya.com>, or such successor site as designated by Avaya.

Contact Avaya Support

See the Avaya Support website: <http://support.avaya.com> for Product or Hosted Service notices and articles, or to report a problem with your Avaya Product or Hosted Service. For a list of support telephone numbers and contact addresses, go to the Avaya Support website: <http://support.avaya.com> (or such successor site as designated by Avaya), scroll to the bottom of the page, and select Contact Avaya Support.

Contents

| | |
|--|-----------|
| Chapter 1: Introduction | 7 |
| Purpose | 7 |
| Related Resources | 7 |
| Documentation | 7 |
| Training | 7 |
| Viewing Avaya Mentor videos | 7 |
| Support | 10 |
| Chapter 2: New in this release | 13 |
| Chapter 3: Hardware compatibility | 15 |
| Platform power supplies | 16 |
| Supported optical devices | 17 |
| Chapter 4: Installing the Avaya VSP 4000 4850GTS Series | 23 |
| Installation fundamentals | 23 |
| Electrostatic discharge | 24 |
| Preventing electrostatic discharge damage | 24 |
| Preventing electrostatic damage in new cable installations | 25 |
| Environmental requirements | 26 |
| Package contents | 27 |
| Installing the Avaya Virtual Services Platform 4000 on a table or shelf | 28 |
| Installing the Avaya Virtual Services Platform 4000 in an equipment rack | 29 |
| Cable requirements for the Avaya Virtual Services Platform 4000 | 31 |
| Installation and removal of Small Form-factor Pluggable (SFP) transceivers | 32 |
| Installing SFP transceivers | 32 |
| Removing SFP transceivers | 33 |
| RJ-45 connector pin assignments | 33 |
| Connector pin assignments for Avaya VSP 4000 switches | 34 |
| Console port pin assignments | 34 |
| Power specifications for the Avaya Virtual Services Platform 4000 | 35 |
| Power specifications for Avaya VSP 4000 switches 4850GTS and 4850GTS-PWR+ | 35 |
| Avaya Virtual Services Platform power supply power specification | 36 |
| DC power supply specifications | 38 |
| Installing the Avaya Virtual Services Platform 4000 power supply | 39 |
| Connect AC power | 39 |
| Power cord specifications | 40 |
| Connect power to the back panel | 41 |
| Check Light Emitting Diode (LED) on the Avaya Virtual Services Platform 4000 | 42 |
| Front panel LEDs | 42 |
| Switch LED state indicators | 43 |
| Port LED state indicators | 44 |
| Chapter 5: Translations of safety messages | 47 |

Chapter 1: Introduction

Purpose

This guide provides information and instructions to install a Virtual Services Platform 4000 (VSP 4850GTS Series).

Related Resources

Documentation

See *Documentation Roadmap for Avaya Virtual Services Platform 4000*, (NN46251–100), for a list of the documentation for this product.

Training

Ongoing product training is available. For more information or to register, you can access the Web site at www.Avaya-learning.com.

Viewing Avaya Mentor videos

Avaya Mentor videos provide technical content on how to install, configure, and troubleshoot Avaya products.

About this task

Videos are available on the Avaya Support web site, listed under the video document type, and on the Avaya-run channel on YouTube.

- To find videos on the Avaya Support web site, go to <http://support.avaya.com>, select the product name, and select the *videos* checkbox to see a list of available videos.
- To find the Avaya Mentor videos on YouTube, go to <http://www.youtube.com/AvayaMentor> and perform one of the following actions:
 - Enter a key word or key words in the Search Channel to search for a specific product or topic.
 - Scroll down Playlists, and click the name of a topic to see the available list of videos posted on the site.

 **Note:**

Videos are not available for all products.

Subscribing to e-notifications

Subscribe to e-notifications to receive an email notification when documents are added to or changed on the Avaya Support web site.

About this task

You can subscribe to different types of general notifications, for example, Product Correction Notices (PCN), that apply to any product or a specific product. You can also subscribe to specific types of documentation for a specific product, for example, Application & Technical Notes for Ethernet Routing Switch 8800.

Procedure

1. In an Internet browser, go to <https://support.avaya.com>
2. Type your username and password, and then click **LOG IN**.
3. Click **MY PROFILE**.



4. On the site toolbar, click your name, and then select **E Notifications**.



5. In the GENERAL NOTIFICATIONS area, select the required documentation types, and then click **UPDATE**.

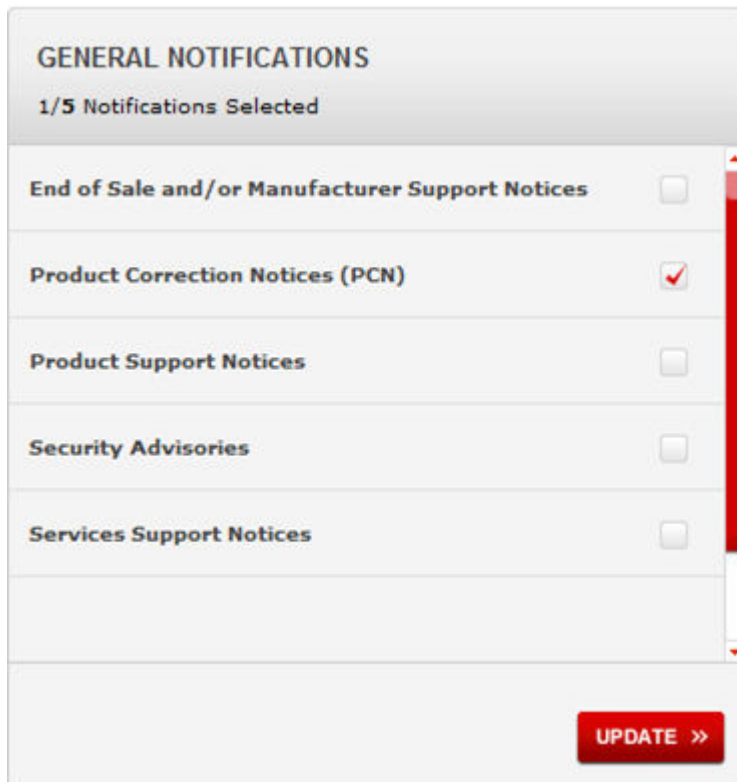

6. Click **OK**.
7. In the PRODUCT NOTIFICATIONS area, click **Add More Products**.

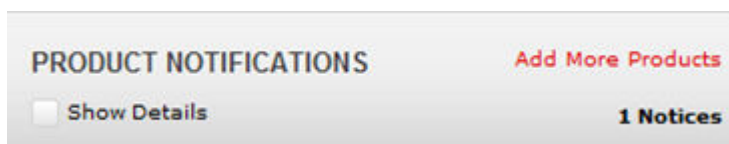

8. Scroll through the list, and then select the product name.
9. Select a release version.

10. Select the check box next to the required documentation types.

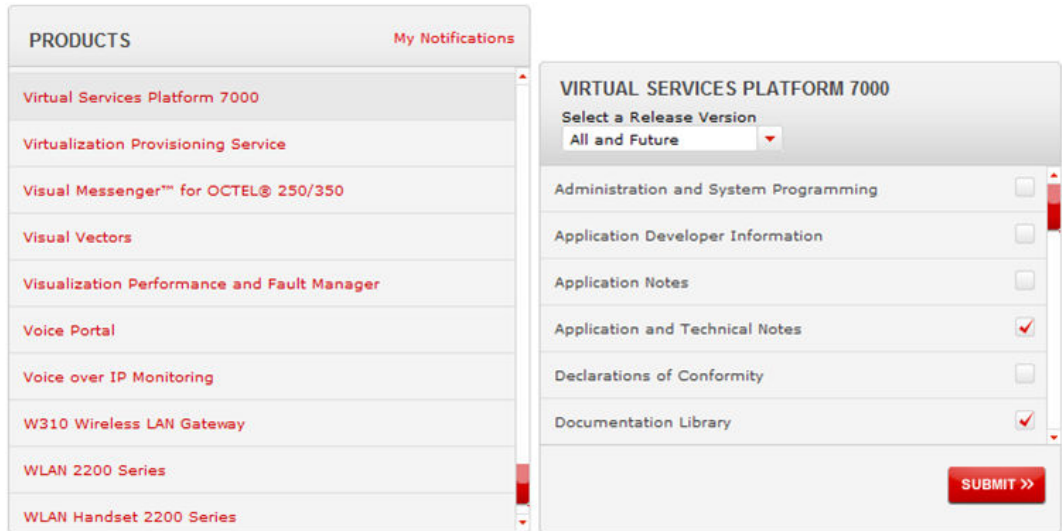

11. Click **Submit**.

Support

Visit the Avaya Support website at <http://support.avaya.com> for the most up-to-date documentation, product notices, and knowledge articles. You can also search for release notes, downloads, and resolutions to issues. Use the online service request system to create a service request. Chat with live agents to get answers to questions, or request an agent to connect you to a support team if an issue requires additional expertise.

Searching a documentation collection

On the Avaya Support website, you can download the documentation library for a specific product and software release to perform searches across an entire document collection. For example, you can perform a single, simultaneous search across the collection to quickly find all occurrences of a particular feature. Use this procedure to perform an index search of your documentation collection.

Before you begin

- Download the documentation collection zip file to your local computer.
- You must have Adobe Acrobat or Adobe Reader installed on your computer.

Procedure

1. Extract the document collection zip file into a folder.
 2. Navigate to the folder that contains the extracted files and open the file named *<product_name_release>.pdx*.
 3. In the Search dialog box, select the option **In the index named *<product_name_release>.pdx***.
 4. Enter a search word or phrase.
 5. Select any of the following to narrow your search:
 - Whole Words Only
 - Case-Sensitive
 - Include Bookmarks
 - Include Comments
 6. Click **Search**.

The search results show the number of documents and instances found. You can sort the search results by Relevance Ranking, Date Modified, Filename, or Location. The default is Relevance Ranking.
-

Chapter 2: New in this release

This document is new in Release 4.0.

New in this release

Chapter 3: Hardware compatibility

The following table describes the Avaya Virtual Services Platform 4000 hardware.

Table 1: Hardware

| VSP 4000 model | Description | Part number |
|------------------|---|--------------|
| VSP 4850GTS | <ul style="list-style-type: none"> • 48 10/100/1000 BaseTX RJ-45 ports • two shared SFP ports • two 1/10GE SFP+ ports • Base Software License • one (of two) field replaceable 300W PSUs supplied with the chassis | EC4800A78-E6 |
| | <ul style="list-style-type: none"> • Same content as EC4800A78-E6 with a EU power cord. | EC4800B78-E6 |
| | <ul style="list-style-type: none"> • Same content as EC4800A78-E6 with a UK power cord. | EC4800C78-E6 |
| | <ul style="list-style-type: none"> • Same content as EC4800A78-E6 with a JP power cord. | EC4800D78-E6 |
| | <ul style="list-style-type: none"> • Same content as EC4800A78-E6 with a NA power cord. | EC4800E78-E6 |
| | <ul style="list-style-type: none"> • Same content as EC4800A78-E6 with a EU power cord. | EC4800F78-E6 |
| VSP 4850GTS-PWR+ | <ul style="list-style-type: none"> • 48 10/100/1000 802.3at PoE+ • two shared SFP ports • two 1/10GE SFP+ ports • Base Software License • one (of two) field replaceable 1000W PSUs supplied with the chassis | EC4800A88-E6 |
| | <ul style="list-style-type: none"> • Same content as EC4800A88-E6 with a EU power cord. | EC4800B88-E6 |
| | <ul style="list-style-type: none"> • Same content as EC4800A88-E6 with a UK power cord. | EC4800C88-E6 |

| VSP 4000 model | Description | Part number |
|----------------|--|--------------|
| | • Same content as EC4800A88-E6 with a JP power cord. | EC4800D88-E6 |
| | • Same content as EC4800A88-E6 with a NA power cord. | EC4800E88-E6 |
| | • Same content a EC4800A88-E6 with a AU power cord. | EC4800F88-E6 |
| VSP 4850GTS DC | <ul style="list-style-type: none"> • 48 10/100/1000 Base TX RJ-45 ports • two shared SFP ports • two 1/10GE SFP+ ports • one (of two) field replaceable 300W DC PSUs supplied with the chassis | EC4800078-E6 |

Platform power supplies

The Virtual Services Platform 4000 supports both AC and DC power supplies. One power supply is installed in the system.

You can install a redundant power supply to support additional power requirements or to provide power redundancy.

The following table describes the Avaya Virtual Services Platform 4000 compatible AC and DC power supplies and their part numbers (order codes). All the power supplies are EUED RoHS 5/6 compliant.

*** Note:**

The 300W and 1000W AC power supplies use the IEC 60320 C16 AC power cord connector.

Use the order codes to order a replacement for the primary PSU or to order a redundant PSU for your VSP 4000 system.

Table 2: Power supply order codes

| VSP 4000 PSU | Usage | Part number (order code) |
|----------------------|---|--------------------------|
| 300W AC power supply | For use in the ERS 4626GTS, 4850GTS, VSP 4850GTS and WL8180, WL8180-16L wireless controllers. | AL1905?08-E5* |

| VSP 4000 PSU | Usage | Part number (order code) |
|---|---|--------------------------|
| Stackable 1000W AC POE+ power supply | For use in 4850GTS-PWR+ and 4450GSX-PWR + models. | AL1905?21-E6* |
| 300W DC power supply | For use in the VSP 4850GTS-DC, ERS5698TFD, 5650TD, and 5632FD. DC connector included. | AL1905005-E5 |
| <p>*Note: The seventh character (?) of the switch order number must be replaced with the proper letter to indicate desired product nationalization. See the following for details:</p> <p>“A”: No power cord included.</p> <p>“B”: Includes European “Schuko” power cord common in Austria, Belgium, Finland, France, Germany, The Netherlands, Norway, and Sweden.</p> <p>“C”: Includes power cord commonly used in the United Kingdom and Ireland.</p> <p>“D”: Includes power cord commonly used in Japan.</p> <p>“E”: Includes North American power cord.</p> <p>“F”: Includes Australian power cord.</p> | | |

Supported optical devices

Use optical devices to achieve high bit-rate communications and long transmission distances. The following section describes the supported optical devices on the VSP 4000 system.

Important:

Avaya recommends that you use Avaya branded SFP and SFP+ transceivers as they undergo extensive qualification and testing. Avaya is not responsible for any problems that arise from using non-Avaya branded SFP and SFP+ transceivers.

Small form factor (SFP) pluggable transceivers

SFPs are hot-swappable input and output enhancement components designed to allow gigabit Ethernet ports to link with other gigabit Ethernet ports over various media types.

You can use various SFP (1Gb/s) and SFP+ (10Gb/s) to attain different line rates and reaches. The following table describes the SFPs including the reach provided by various SFPs.

This table is informational only—not all Avaya Ethernet switching and routing products support all the SFPs listed here.

For more information about SFP and SFP+ transceivers, including technical specifications and installation instructions, see *Installing Transceivers and Optical components on the Avaya Virtual Services Platform 4000*, NN46251-301.

! Important:

The attainable cable length can vary depending on the quality of the fiber optic cable used.

Table 3: Supported SFP transceivers

| Model | ROHS product number | Description |
|-------------------|---|--|
| 1000BASE-T | AA1419043-E6 | CAT5 UTP, up to 100 m. Because the 1000BASE-T device is all electrical, it does not need DDI support. |
| 1000BASE-SX DDI | AA1419048-E6 | 850 nm up to 275 m using 62.5 m MMF optic cable up to 550 m using 50 µm MMF optic cable |
| 1000BASE-LX DDI | AA1419049-E6 | 1310 nm, up to 10 km |
| 1000BASE-XD DDI | AA1419050-E6 | 1310 nm, up to 40 km This transceiver has been discontinued but remains supported by the software. |
| | AA1419051-E6 | 1550 nm, up to 40km (non-CWDM) This transceiver has been discontinued but remains supported by the software. Avaya recommends AA1419057-E6 as a replacement. |
| 1000BASE-ZX DDI | AA1419052-E6 | 1550 nm, up to 70 km (non-CWDM) This transceiver has been discontinued but remains supported by the software. Avaya recommends AA1419065-E6 as a replacement. |
| 1000BASE-BX DDI | AA1419069-E6 and AA1419070-E6 mating pair | One model transmits at 1310 nm and receives at 1490 nm, while the mating model transmits at 1490 nm and receives at 1310 nm. The reach is up to 10km. |
| | AA1419076-E6 and AA1419077-E6 mating pair | One model transmits at 1310 nm and receives at 1490 nm, while the mating model transmits at 1490 nm and receives at 1310 nm. The reach is up to 40km. |
| 1000BASE-EX DDI | AA1419071-E6 | 1550 nm, up to 120 km (non-CWDM) |
| 1000BASE DDI CWDM | AA1419053-E6 | 1470 nm, up to 40 km |

| Model | ROHS product number | Description |
|------------|---------------------|----------------------|
| | AA1419054-E6 | 1490 nm, up to 40 km |
| | AA1419055-E6 | 1510 nm, up to 40 km |
| | AA1419056-E6 | 1530 nm, up to 40 km |
| | AA1419057-E6 | 1550 nm, up to 40 km |
| | AA1419058-E6 | 1570 nm, up to 40 km |
| | AA1419059-E6 | 1590 nm, up to 40 km |
| | AA1419060-E6 | 1610 nm, up to 40 km |
| | AA1419061-E6 | 1470 nm, up to 70 km |
| | AA1419062-E6 | 1490 nm, up to 70 km |
| | AA1419063-E6 | 1510 nm, up to 70 km |
| | AA1419064-E6 | 1530 nm, up to 70 km |
| | AA1419065-E6 | 1550 nm, up to 70 km |
| | AA1419066-E6 | 1570 nm, up to 70 km |
| | AA1419067-E6 | 1590 nm, up to 70 km |
| | AA1419068-E6 | 1610 nm, up to 70 km |
| 100BASE-FX | AA1419074-E6 | 1310 nm, up to 2km |

Small form factor (SFP+) pluggable plus transceivers

SFP+ transceivers are hot-swappable input and output enhancement components that allow 10 gigabit connections. All Avaya SFP+ transceivers use Lucent connectors (LC) to provide precision keying and low interface losses.

The following table lists and describes the Avaya SFP+ models.

Table 4: Supported SFP+ transceivers and cables

| Model number | Part number | Description |
|---------------------|---------------------------------|--|
| 10GBASE-CX | AA1403018-E6 to AA1403021-E6 | 4-pair twinaxial copper cable to connect 10 Gb ports. The maximum range is 15 m. |
| 10GBASE-ER/EW | AA1403013-E6 | 1550 nm SMF. The range is up to 40 km. |
| 10GBASE-ER CWDM DDI | AA1403153-E6 | 1471 nm SMF. The range is up to 40 km. |
| | AA1403154-E6 | 1491 nm SMF. The range is up to 40 km. |

| Model number | Part number | Description |
|---------------------|--------------|---|
| | AA1403155-E6 | 1511 nm SMF. The range is up to 40 km. |
| | AA1403156-E6 | 1531 nm SMF. The range is up to 40 km. |
| | AA1403157-E6 | 1551 nm SMF. The range is up to 40 km. |
| | AA1403158-E6 | 1571 nm SMF. The range is up to 40 km. |
| | AA1403159-E6 | 1591 nm SMF. The range is up to 40 km. |
| | AA1403160-E6 | 1611 nm SMF. The range is up to 40 km. |
| 10GBASE-LR/LW | AA1403011-E6 | 1310 nm SMF. The range is up to 10 km. |
| 10GBASE-LRM | AA1403017-E6 | 1310 nm. Up to 220 m reach over Fiber Distributed Data Interface (FDDI)-grade 62.5 µm multimode fiber. Suited for campus LANs. |
| 10GBASE-SR/SW | AA1403015-E6 | 850 nanometers (nm). The range is up to the following: <ul style="list-style-type: none"> • 26 m using 62.5 micrometer (µm), 160 megaHertz times km (MHz-km) MMF • 33 m using 62.5 µm, 200 MHz-km MMF • 66 m using 62.5 µm, 400 MHz-km MMF • 82 m using 50 µm, 500 MHz-km MMF • 300 m using 50 µm, 2000 MHz-km MMF • 400 m using 50 µm, 4700 MHz-km MMF (OM4) |
| 10GBASE-ZR/ZW | AA1403016-E6 | 1550 nm SMF. The range is up to 70 km. |
| 10GBASE-ZR CWDM DDI | AA1403161-E6 | 1471 nm SMF. The range is up to 70 km. |

| Model number | Part number | Description |
|--------------|--------------|--|
| | AA1403162-E6 | 1491 nm SMF. The range is up to 70 km. |
| | AA1403163-E6 | 1511 nm SMF. The range is up to 70 km. |
| | AA1403164-E6 | 1531 nm SMF. The range is up to 70 km. |
| | AA1403165-E6 | 1551 nm SMF. The range is up to 70 km. |
| | AA1403166-E6 | 1571 nm SMF. The range is up to 70 km. |
| | AA1403167-E6 | 1591 nm SMF. The range is up to 70 km. |
| | AA1403168-E6 | 1611 nm SMF. The range is up to 70 km. |

Optical power considerations

When you connect the device to collocated equipment, ensure that enough optical attenuation exists to avoid overloading the receivers of each device. You must consider the minimum attenuation requirement based on the specifications of third-party equipment. For more information about minimum insertion losses for Avaya optical products, see *Installing Transceivers and Optical components on the Avaya Virtual Services Platform 4000*, NN46251-301.

Chapter 4: Installing the Avaya VSP 4000 4850GTS Series

Installation fundamentals

The following section describes the installation fundamentals for the VSP 4850GTS series.

The VSP 4850GTS series consists of the following models:

- VSP 4850GTS
- VSP 4850GTS DC
- VSP 4850GTS-PWR+

VSP 4850GTS series models

The VSP 4850GTS series models consist of:

- 48 10/100/1000 Base TX ports
 - RJ-45 for the VSP 4850GTS and VSP 4850GTS DC models
 - 802.3at PoE+ for the VSP 4850GTS-PWR+ model
- two shared SFP ports
 - These ports support copper and fiber on the same switch port. Only one medium type can be active at any time.
 - There is an RJ-45 connector and an SFP slot for each combo port. A cable can be inserted into either or both medium types.
 - Fiber connections take precedence over copper.
 - Configuration for the port is applicable to both medium types. For example, auto-negotiation configuration applies to both the copper and fiber ports.
- two 1/10GE SFP+ ports



Figure 1: VSP 4850GTS

1. VSP 4000 USB device with USB device cover

⚠ Caution:

On a factory-supplied VSP 4000 switch, ensure that the USB device is inserted in the system at all times with the USB cover on. Otherwise system operation is affected.

2. Switch LEDs
3. 10/100/1000 PoE+ ports (LEDs above ports)
4. Combo port SFP slots. Supports Avaya 1G SFPs and 100Base low speed SFPs.
5. SFP+ slots. Supports Avaya's 1G SFPs and 10G SFP+s.
6. Console Port

Electrostatic discharge

This section provides information and procedures to prevent electrostatic discharge during installation.

Preventing electrostatic discharge damage

Electrostatic discharge (ESD) is a discharge of stored static electricity that can damage equipment and impair electrical circuitry. Electrostatic voltages can result from friction including, pulling cabling through conduits, walking across carpeted areas, and building static charge in clothing. When you improperly handle electronic components, ESD damage occurs and can result in complete or intermittent failures. While networking equipment is commonly designed and tested to withstand common mode ESD events, voltage can sometimes discharge to some connector pins, which can potentially damage the networking equipment.

⚠ Caution:

To protect the Avaya VSP 4000 against ESD damage, take the following measures before you connect data cables to the device:

- Always use antistatic wrist straps. Make sure you adjust the strap to provide good skin contact.
- Ensure that you properly ground work surfaces and equipment racks for protection against electrostatic discharge. You must connect the common point to the building ground wire. In a properly wired building, the nearest reliable ground is typically at the electrical outlet.
- Avoid contact between equipment and clothing. The wrist or ankle strap protects only the equipment from ESD voltages on the body; ESD voltages on clothing can still cause damage.
- Avoid touching any connector pins.
- Do not remove the wrist or ankle strap until the installation is complete.

Preventing electrostatic damage in new cable installations

With new cable installations, Avaya recommends that you use an ESD discharge cable to reduce the potential for damage from static, that can build up in cables. The following figure illustrates an ESD cable.

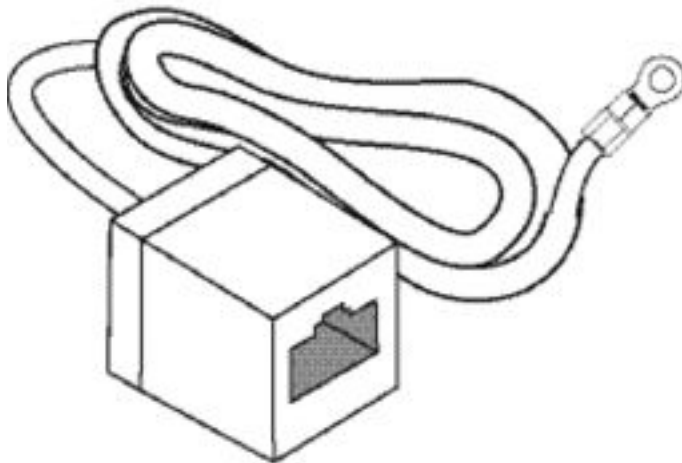

Figure 2: Job aid

To install the ESD discharge cable, perform this procedure.

1. Connect the ground lug on the ESD discharge cable to a safe and suitable earth ground.
2. Connect all RJ-45 cable connectors to the female RJ-45 connector of the ESD discharge cable for at least 5 seconds, and then connect each RJ-45 cable connector to the switch.
3. Leave cables connected to the networking equipment. After you connect cables to networking equipment, the cables do not build up charge.

Environmental requirements

The following table provides the environmental requirements for the individual switches in this series. Ensure that the area where you install the switch and where it operates meets these requirements.

Table 5: Avaya Virtual Services Platform 4000 environmental requirements

| Environmental requirement | Avaya Virtual Services Platform 4000 models |
|--|--|
| Operating Temperature | 0°C to 50°C (32°F to 104°F) |
| Storage Temperature | -40°C to 85°C (-13°F to 158°F) |
| Operating and Storage Humidity | 0 to 95 percent noncondensing |
| Maximum Operating Altitude | 3,048m (10 000 feet) above sea level |
| Altitude | 0 to 3,048m (0 to 10,000ft) above sea level |
| Storage Altitude | 0 to 12,192m (0 to 40,000ft) above sea level |
| Acoustic Noise | Less than or equal to 45 db at 35°C and less than or equal to 57 db at 50°C. The temperature is allowed to have ±3.5°C deviation around the threshold of 35C, (measurement methods based on ISO 7779). |
| Miscellaneous Operating Considerations | <ul style="list-style-type: none"> • No heat sources such as hot air vents or direct sunlight near the switch. • No sources of severe electromagnetic interference near the switch. • No excessive dust in the environment. • An adequate power source is within 6 feet (1.83 meters) of the switch. One 15-amp circuit is required for each power supply. |

| Environmental requirement | Avaya Virtual Services Platform 4000 models |
|---------------------------|--|
| | <ul style="list-style-type: none"> • At least 2 inches (5.08 centimeters) of clearance on each side of the switch unit for ventilation. • Adequate clearance at the front and rear of the switch for access to cables. |

 **Warning:**

To avoid bodily injury from hazardous electrical shock and current, never remove the top of the device. No user-serviceable components are inside. For a translation of this statement, see [Translations of safety messages](#) on page 47.

Package contents

The following describes the components that are provided with each switch. If any components are missing, contact the switch vendor.

1. Avaya Virtual Services Platform 4000 4850GTS switch with one power supply installed
2. Rack-mounting hardware that includes:
 - Rack-mount brackets
 - Screws to attach brackets to the switch
 - Screws to attach the switch to the equipment rack
3. Rubber footpads
4. AC power cord with an IEC 60320 C16 connector.

 **Note:**

A power cord is not included for the A variant of the switch.

5. Documentation that includes the following:
 - a. Locating the latest software and product Release Notes (NN46251–106)
 - b. The Regulatory guide (NN46251–105)
 - c. The Quick Install guide (NN46251–302)
 - d. The China RoHS paper

 **Note:**

Cable trays can be provided as an option.

Installing the Avaya Virtual Services Platform 4000 on a table or shelf

You can install a single Avaya VSP 4000 switch on any flat surface. The surface must support the combined weight of the switch and attached cables (from 15 and 20 pounds [7 to 9 kilograms]).

To install an Avaya VSP 4000 on a table or shelf, perform this procedure.

 **Caution:**

Do not place an Avaya Ethernet Power Supply Unit or Avaya Ethernet Redundant Power Supply on top of an Avaya VSP 4000. The switch housing of an Avaya VSP 4000 cannot support the weight of these units. For a translation of this statement, see [Translations of safety messages](#) on page 47.

1. Remove the screws that hold the USB cover but do *not* remove the USB cover.

 **Caution:**

On a factory-supplied **4850GTS series** switch, do not remove the USB device cover or the USB device from the slot. Removing the USB device affects system operation and may even prevent the system from booting up successfully. Ensure that the USB device is inserted in the system at all times with the USB cover on.

2. Attach the included rubber footpads on the bottom of the switch at the locations indicated.

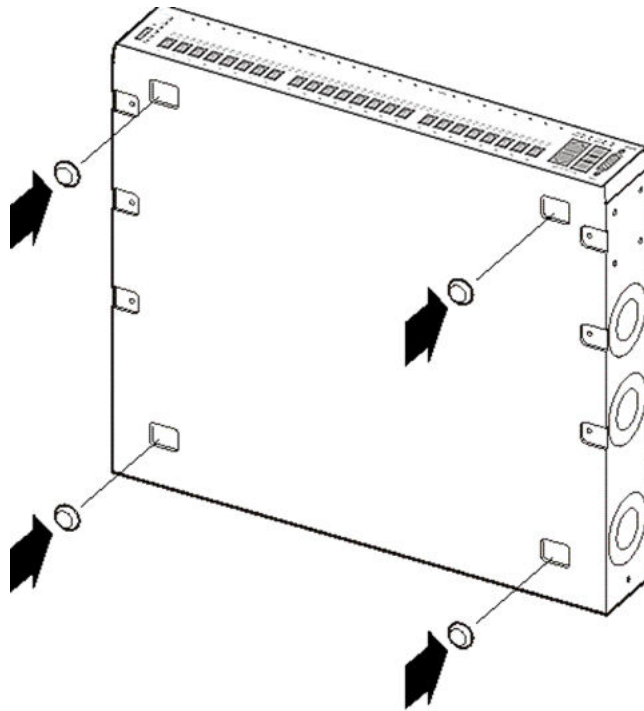

10753FC

3. Set the switch on a table or shelf as illustrated below. Allow at least 2 inches (5.1 centimeters) on each side for proper ventilation and at least 5 inches (12.7 centimeters) at the back for power cord clearance.

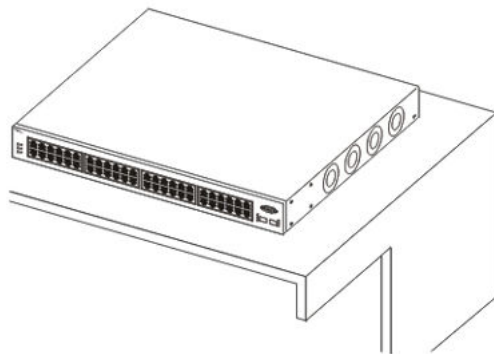

10754FC

Installing the Avaya Virtual Services Platform 4000 in an equipment rack

To install an Avaya VSP 4000 switch in an equipment rack, perform this procedure.

Prerequisites for installing the Avaya Virtual Services Platform 4000 in an equipment rack:

- Ensure that you have a space of 1.75 inches (4.45 centimeters) in height for each switch in an EIA or IEC-standard 19-inch (48.2-centimeter) equipment rack.
- The rack is bolted to the floor and braced if necessary.
- The rack is grounded to the same grounding electrode used by the power service in the area. The ground path must be permanent and must not exceed 1 Ohm of resistance from the rack to the grounding electrode.

 **Caution:**

When you mount the device in a rack, do not stack units directly on top of one another. You must secure each unit to the rack with the appropriate mounting brackets. Mounting brackets cannot support multiple units. For a translation of this statement, see [Translations of safety messages](#) on page 47.

1. Remove the screws that hold the USB cover but do *not* remove the USB cover.

 **Caution:**

On a factory-supplied **4850GTS series** switch, do not remove the USB device cover or the USB device from the slot. Removing the USB device affects system operation and may even prevent the system from booting up successfully. Ensure that the USB device is inserted in the system at all times with the USB cover on.

2. Attach the L-bracket to each side of the switch using a #2 Phillips screwdriver as illustrated below.

 **Important:**

On a factory-supplied 4850GTS series switch, ensure that the L-bracket goes over the USB cover.

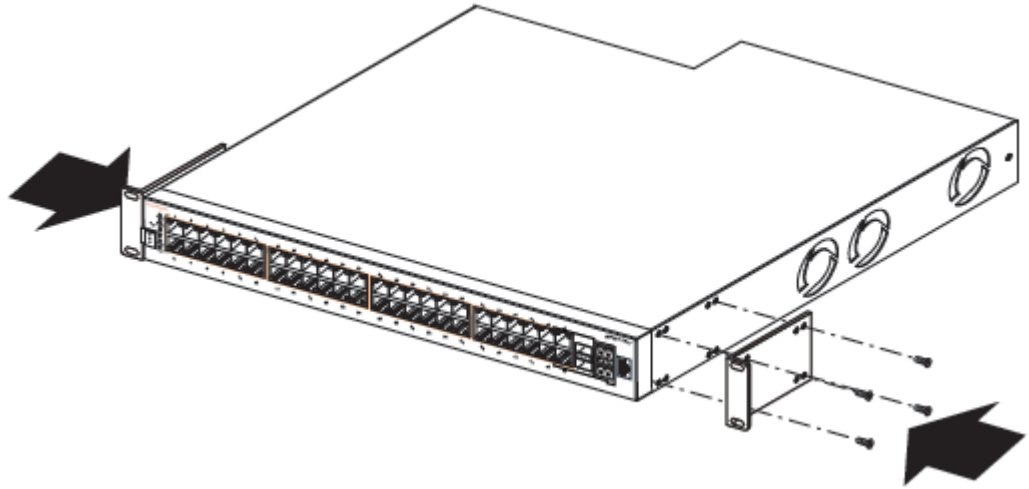

3. Slide the switch into the rack as illustrated.

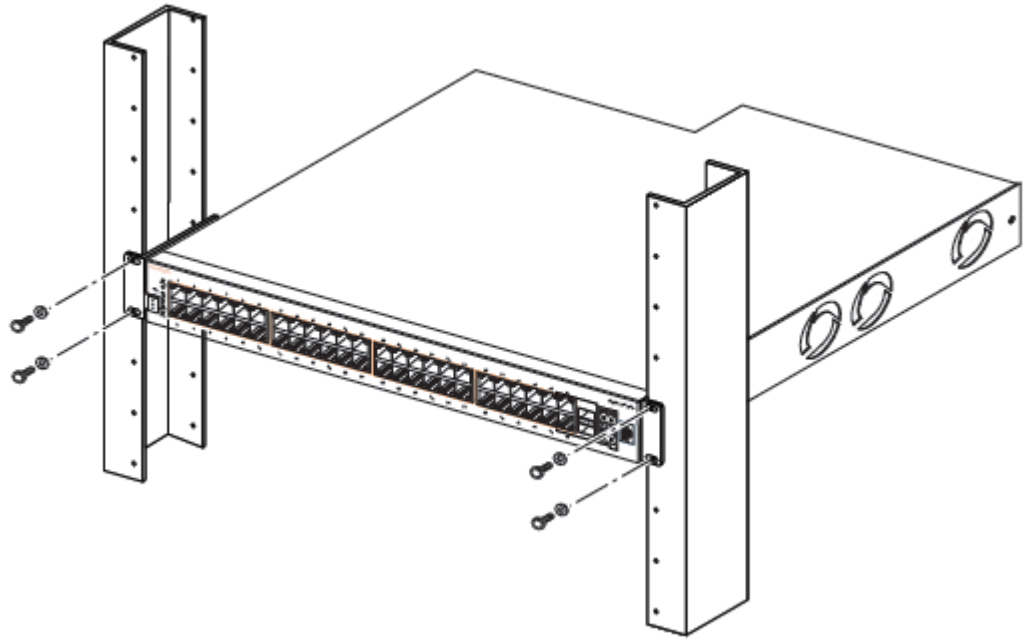

4. Insert and tighten the rack-mount screws.

Cable requirements for the Avaya Virtual Services Platform 4000

The following table describes the cables required for a an Avaya Virtual Services Platform 4000 switch.

Table 6: Switch cable requirements

| Required Cable | Description |
|--------------------------|--|
| 10/100/1000Base TX Ports | The interconnect cabling must conform to the Cat5e, Cat6, or Cat6e specification of the Commercial Building Telecommunications Cabling Standard, ANSI/TIA/EIA 568-B fitted with an RJ-45 Module jack. |
| 10/100Base TX Ports | The interconnect cabling for 10BaseT Ethernet must conform to Cat3, Cat4, Cat5 (or better) UTP cabling for distances up to 100 meters. The interconnect cabling for 100BaseTX Fast Ethernet must conform to Cat5 (or better) UTP cabling for distances up to 100 meters. |
| 100BaseFX Ports | The interconnect cabling must conform to 50/125 or 62.5/125 micron multimode fiber-optic cabling for distances up to 3 kilometers. |
| Console Port | Varies depending on the user device. The VSP 4000 has an RJ-45 female connector, so a serial cable with RJ-45 connectors, or a serial cable with a DB-9 female connector on one end and an RJ-45 on the other is appropriate. The maximum length for the console port cable is 25 feet (8.3 meters). |
| SFP Transceiver Ports | Varies with the installed SFP transceiver. See the documentation shipped with the SFP transceiver for specifications. |
| USB Port | The USB port is not user accessible on the VSP 4000. |

Installation and removal of Small Form-factor Pluggable (SFP) transceivers

The following section describes how to install and remove Small Form-factor Pluggable (SFP) transceivers in the Avaya Virtual Services Platform 4000 switch. For more information about SFP transceiver use and designation, see *Installing Transceivers and Optical components on the Avaya Virtual Services Platform 4000* (NN46251–301).

Installing SFP transceivers

Install SFP transceivers by performing this procedure.

1. Remove the transceiver from the protective packaging.
2. Verify that the transceiver is the correct model for the network configuration.
3. Grasp the transceiver between your thumb and forefinger.
4. Insert the transceiver into the proper module on the switch. Apply a light pressure to the transceiver until it clicks and locks into position in the module.
5. Remove the dust cover from the transceiver optical bores.

Removing SFP transceivers

Remove SFP transceivers by performing this procedure.

1. Disconnect the network fiber cable from the transceiver.
2. Use the locking mechanism on the transceiver to release it. The locking mechanism varies from model to model as illustrated below.

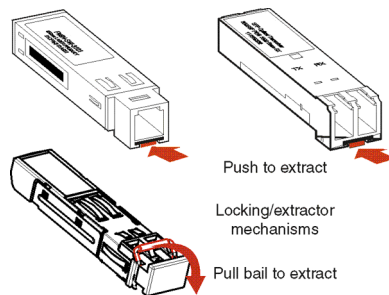

3. Slide the transceiver from the module slot.
4. If the transceiver does not slide easily from the module slot, use a gentle side-to-side rocking motion while firmly pulling the transceiver from the slot.
5. Attach a dust cover over the fiber-optic bores and store the transceiver in a safe place until you need it.

! Important:

Discard transceivers in accordance with the proper laws and regulations.

RJ-45 connector pin assignments

The following section describes the connector pin assignments for the RJ-45 connectors in the Avaya Virtual Services Platform 4000.

Connector pin assignments for Avaya VSP 4000 switches

The following table describes the Power over Ethernet Plus RJ-45 connector pin assignments in the Avaya VSP 4000.

Table 7: PWR+ RJ-45 connector pin assignments

| Connector | Pin Number | Signal | Description |
|--|------------|----------------|-----------------------|
|  <p>87854321 0464EA</p> | 1 | RX+/power- | Receive Data+/power- |
| | 2 | RX-/power- | Receive Data-/power- |
| | 3 | TX+/power+ | Transmit Data+/power+ |
| | 4 | Not applicable | Not applicable |
| | 5 | Not applicable | Not applicable |
| | 6 | TX-/power+ | Transmit Data-/power+ |
| | 7 | Not applicable | Not applicable |
| | 8 | Not applicable | Not applicable |

! Important:

The Avaya VSP 4000 PWR+ models use pins 1, 2, 3, and 6 for PoE+, and is compliant with Type 2 (MDI-X) in IEEE802.3at.

Console port pin assignments

The following table describes the console port pin assignments in the Avaya VSP 4000.

! Important:

Avaya VSP 4000 supports only CLI Quickstart use on the console port.

Table 8: DB-9 Console port pin assignments

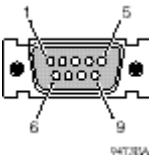
| Connector | Pin Number | Signal |
|--|------------|--------------------------------|
|  <p>04735UA</p> | 1 | Carrier detect (not used) |
| | 2 | Transmit Data (TXD) |
| | 3 | Receive Data (RXD) |
| | 4 | Data terminal ready (not used) |
| | 5 | Signal ground (GND) |

| Connector | Pin Number | Signal |
|-----------|------------|----------------------------|
| | 6 | Not used |
| | 7 | Request to send (not used) |
| | 8 | Not used |
| | 9 | Ring indicator (not used) |

Table 9: RJ-45 Console port pin assignments

| Connector | Pin Number | Signal |
|---|------------|---|
|  | 1 | Ready to send (RTS) — optional |
| | 2 | Data terminal ready (DTR) — optional, can swap or link with pin 8 |
| | 3 | Transmit data (TXD) — mandatory |
| | 4 | Carrier detect (DCD) — optional |
| | 5 | Ground (GND) — mandatory |
| | 6 | Receive data (RXD) — mandatory |
| | 7 | Data set ready (DSR) — optional |
| | 8 | Clear to send (CTS) — optional, can swap or link with pin 1 |

Power specifications for the Avaya Virtual Services Platform 4000

This section describes power specifications for the Avaya VSP 4000 switches.

Power specifications for Avaya VSP 4000 switches 4850GTS and 4850GTS-PWR+

The following table describes the regulatory AC power specifications for the Avaya Virtual Services Platform 4000 4850GTS and 4850GTS-PWR+ switches. The regulatory power specifications are based on the maximum rated capacity of the power supplies and are not based on typical power consumption which is lower.

Table 10: AC power specifications

| | 4850GTS | 4850GTS-PWR+ |
|----------------------|--|---|
| Input Current: | 5A/2.5A | 16.66A/8.33A |
| Input Voltage (rms): | 100 to 240VAC at 50 to 60 Hz | 100 to 240VAC at 50 to 60 Hz |
| Power Consumption: | Typical: 94.6W Maximum: 140W | <ul style="list-style-type: none"> • Without PoE+ <ul style="list-style-type: none"> - Typical: 107W - Maximum: 145W • With PoE+ <ul style="list-style-type: none"> - Typical power utilization depends on the number of ports using PoE+. - Maximum: 1705.2W |
| Thermal Rating: | 323 BTU/Hr maximum | 508 BTU/Hr maximum |
| Inrush Current: | 40A maximum | 70A maximum |
| Turn on Condition: | 1 second maximum after application of AC power | 1 second maximum after application of AC power |
| Efficiency: | 70 percent minimum | 70 percent minimum |

Avaya Virtual Services Platform power supply power specification

The Avaya Virtual Services Platform 4000 supports two external field replaceable power supplies. One power supply ships with the chassis. You can install a secondary power supply to provide redundancy, load sharing, and to add Power over Ethernet Plus (PoE+) power budget on PWR+ models.

1000W AC power supply

VSP 4000 4850GTS-PWR+ supports dual 54V 1000W Power over Ethernet Plus (PoE+) AC power supplies.

Important:

Ensure that you use only 1000W power supplies (both primary and secondary) on VSP 4000 PWR+ models.



Figure 3: 1000W AC power supply

300W AC power supply

The Avaya VSP 4850GTS supports 300W AC power supplies.



Figure 4: 300W AC power supply

Connector

The 300W and 1000W AC power supplies use an IEC 60320 C16 AC power cord connector. The AC power cord is in close proximity to the hot air exhaust, and supports high operating temperatures.

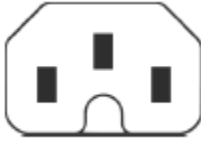

Figure 5: IEC 60320 C16 connector

Power over Ethernet Plus specifications

Table 11: Avaya VSP 4850GTS and 4850GTS-PWR+ models

| Maximum PoE+ W | Average PoE+ W on 50 port model |
|---|---|
| 855W with one power supply 1855W with two power supplies | 15.4W (802.3af) 17.8W (802.3at) — 1 power supply 32.4W (802.3at) — 2 power supplies |

- VSP 4850GTS-PWR+ can support 802.3af 15.4W on each port with one power supply installed. You can add a second power supply for redundancy.
- VSP 4850GTS-PWR+ can support 802.3at 32.4W on each port with two power supplies installed. PoE+ power reduces to an average of 17.8W on each port with one power supply.

DC power supply specifications

The following table describes the DC power supply specifications for the Avaya Virtual Services Platform 4000. For Avaya VSP 4000 AC and DC power supply order codes, see [Platform power supplies](#) on page 16.

Table 12: DC power supply specifications

| | |
|----------------|----------------|
| Description | DC-DC-12V-300W |
| Output power | 300W |
| Input voltage | 48V DC |
| Input current | 10A |
| Output voltage | 12V DC |
| Output current | 25A |

Installing the Avaya Virtual Services Platform 4000 power supply

You must install at least one power supply before using the switch. Avaya VSP 4000 PWR+ models. Avaya VSP 4000 models support two field replaceable external power supplies. If supported, you can install an optional second power supply for redundancy, load sharing, or to provide additional PoE+ power budget.

Perform the following procedure to install an external power supply into your switch.

 **Note:**

Avaya VSP 4000 hardware can vary. This procedure only applies to hardware models with field replaceable power supplies.

1. If a blanking plate covers the required power supply slot, remove the blanking plate before attempting to insert the power supply.
2. Insert each power supply into a rear power supply slot.
3. Verify that each power supply is fully seated in the slot. Secure the power supply with the two thumb screws.

 **Note:**

The switch chassis can prevent an incorrect installation of a power supply. If you insert a power supply upside down, it will not fully insert and the thumb screws will not engage.

4. Once you install a power supply, you can proceed with connecting AC power.

 **Important:**

You can hot swap power supplies while the switch is operational. One power supply is required for continued switch operation. PoE+ load reductions can occur if you remove one power supply while the switch is operating with dual power supplies.





Connect AC power

This section explains power cord specifications and how to connect AC power.

Power cord specifications

To connect AC power to the switch, you need an appropriate AC power cord as described in the following table, also see the following table for plug specifications.

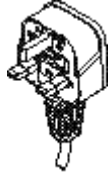
Table 13: International power cord specifications

| Country and Plug Specification | Specifications | Typical Plug |
|--|---|---|
| Continental Europe: • CEE7 standard VII male plug • Harmonized cord (HAR marking on the outside of the cord jacket to comply with the CENELEC Harmonized Document HD-21) | • 220 or 230VAC • 50 Hz • Single phase |  |
| United States of America, Canada, and Japan: • NEMA5-15P male plug • UL-recognized (UL stamped on cord jacket) • CSA-certified (CSA label secured to the cord) | • 100 or 120VAC • 50–60 Hz • Single phase |  |
| United Kingdom: • BS1363 male plug with fuse • Harmonized cord | • 240VAC • 50 Hz • Single phase |  |
| Australia: • AS3112-1981 male plug | • 240VAC • 50 Hz • Single phase |  |

⚠ Danger:

Using power cords with a proper grounding path

Use only power cords that have a grounding path. Without a proper ground, a person who touches the switch is in danger of receiving an electrical shock. Lack of a grounding path to the switch can result in excessive emissions. For a translation of this statement, see [Translations of safety messages](#) on page 47.

Connect power to the back panel

Connect the AC power cord to the back of the switch, and then connect the cord to an AC power outlet. The following figure shows how to connect the AC power cord to the switch back panel.

! **Important:**

The Avaya VSP 4000 series has no AC power switch. When you connect the power cord to a suitable, energized AC power outlet, the switch powers up immediately.

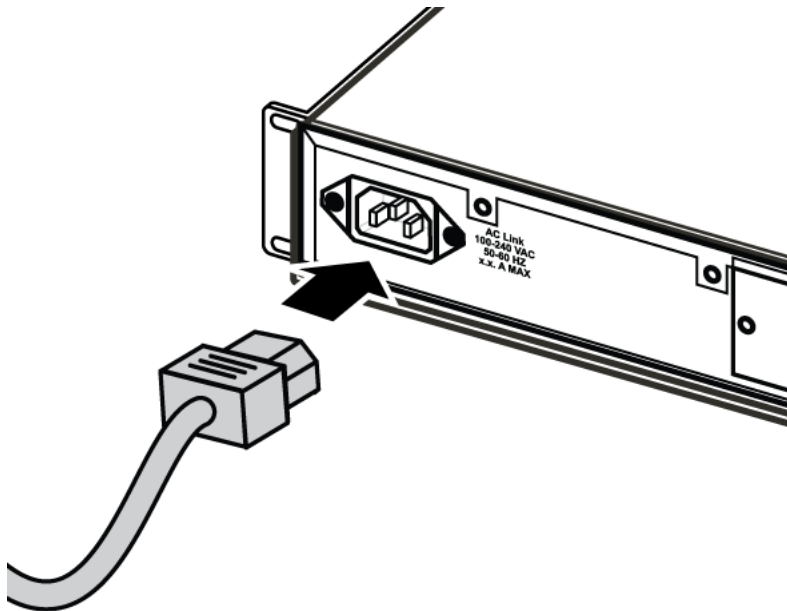

Figure 6: Connecting AC power to the back panel

⚠ Warning:

Disconnecting the AC power cord is the only way to turn off AC power to the Avaya VSP 4000. Always connect the AC power cord in a quickly and safely accessible location in case of an emergency. For a translation of this statement, see [Translations of safety messages](#) on page 47.

⚠ Caution:

Before you unplug the AC power cord, always perform the following shutdown procedure. This procedure flushes any pending data to ensure data integrity.

1. Enter the Privileged EXEC command mode:

```
enable
```

2. Shutdown the VSP 4000:

```
sys shutdown
```

3. Before you unplug the power cord, wait until you see the following message:

```
System Halted, OK to turn off power.
```

Check Light Emitting Diode (LED) on the Avaya Virtual Services Platform 4000

The figures and tables in the following sections describe the LEDs on the Avaya Virtual Services Platform 4000 switches. The tables describe LED operation for a switch that finishes the power-on self-test.

Front panel LEDs

The following diagrams illustrate the components on the front panels of the Avaya VSP 4000 switches.

For detailed explanations of the states indicated by each front panel LED type, see the following sections:

- [Port LED state indicators](#) on page 44
- [Switch LED state indicators](#) on page 43



Figure 7: VSP 4850GTS

1. VSP 4000 USB drive with USB cover
2. Switch LEDs
3. 10/100/1000 ports (LEDs above ports)

4. Combo port SFP slots. Supports Avaya 1G SFPs and 100Base low speed SFPs.
5. SFP+ slots. Supports Avaya's 1G SFPs and 10G SFP+s.
6. Console Port

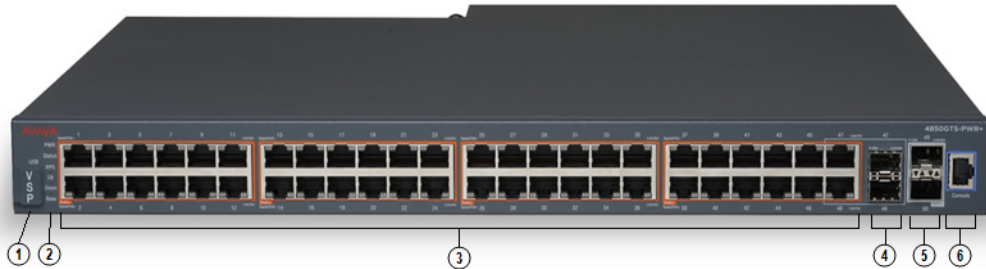

Figure 8: VSP 4850GTS-PWR+

1. VSP 4000 USB drive with USB cover
2. Switch LEDs
3. 10/100/1000 PoE+ ports (LEDs above ports)
4. Combo port SFP slots. Supports Avaya 1G SFPs and 100Base low speed SFPs.
5. SFP+ slots. Supports Avaya's 1G SFPs and 10G SFP+s.
6. Console Port

⚠ Warning:

Fiber optic equipment can emit laser or infrared light that can injure your eyes. Never look into an optical fiber or connector port. Always assume that fiber-optic cables are connected to a light source. For a translation of this statement, see [Translations of safety messages](#) on page 47.

Switch LED state indicators

The following figure describes the main switch LED state indications provided by LED color and fluctuation cues.

*** Note:**

Indicator states are applicable to all models of VSP 4000 switches.

Table 14: Switch LED state indicators

| Label | Color and Status | Description |
|--------|------------------|--|
| PWR | Green (solid) | The switch is receiving power either from the primary or secondary power supply. Normal operation. |
| | Off | The switch is not receiving power and not operating. |
| Status | Green (solid) | <ul style="list-style-type: none"> • During start-up: The power-on self-test (POST) is complete and the switch is operating normally. • After start-up: The switch is running the agent code successfully. |
| | Green (blinking) | The switch is loading the agent software code. |
| | Amber (solid) | The switch encountered an error when running the diagnostic software. |
| | Amber (blinking) | The switch is booting and running diagnostic software. Normal activity during boot process. |
| | Off | The switch failed the power-on self-test (POST) or failed to load the agent code. |
| RPS | Green (solid) | The switch is connected to a redundant power supply unit (RPS) or a secondary external power supply, and is operating normally. |
| | Green (blinking) | The switch is connected to a secondary power supply, but the power input is disconnected. |
| | Amber (solid) | The power supply in slot 1 or slot 2 was removed after operating. |
| | Amber (blinking) | The power supply in slot 1 or slot 2 is present, but not supplying power to the switch. |
| | Off | No power to secondary power supply. The switch is not connected to an RPS or secondary power supply. The RPS is not supplying power, or the DC/DC module is not supplying power.. |

Port LED state indicators

This section describes the port LED state indicators by color and fluctuation cues.

 **Note:**

Indicator states are applicable to all models of VSP 4000 switches.

The following list describes the three port LEDs:

- Activity indicates the level of activity on the link.
- Link indicates the presence of an Ethernet link.
- Speed indicates the port speed (for example, 10 Mb/s, 100 Mb/s, 1000 Mb/s).

Table 15: RJ-45 Port LED state indicators

| Label | Color and Status | Description |
|-----------------|--------------------|---|
| Speed/PoE+ | Green, Blink | The port is set to operate at 1000 Mb/s with PoE. |
| | Green, Steady | The port is set to operate at 1000 Mb/s without PoE+. |
| | Amber, Blink | The port is set to operate at 100 Mb/s with PoE+. |
| | Amber, Steady | The port is set to operate at 100 Mb/s without PoE+. |
| | Amber, Green Pulse | The port is experiencing a PoE+ error. |
| | Off | When the Link/Activity LED is green and the Speed LED is off, the port is set to operate at 10 Mb/s for all models. |
| Link / Activity | Green, Steady | The link established but no data activity exists. |
| | Green, Blink | The link is established and data activity exists (the blink rate indicates the level of activity). |
| | Green, Slow Blink | The software disabled the port. |
| | Amber, Steady | Port disabled. |
| | Amber, Blink | Port not used. |

Table 16: SFP/SFP+ transceiver Port LED state indicators

| Label | Color and Status | Description |
|-----------------|------------------|--|
| In Use | Green, Blink | Not applicable. |
| | Green, Steady | The SFP port and the transmit port are active. |
| | Amber, Blink | Not applicable. |
| | Amber, Steady | SFP Installed—TX Port Inactive |
| | Off | No SFP transceiver is present. |
| Link / Activity | Green, Blink | Activity exists on the port. |

| Label | Color and Status | Description |
|-------|-------------------|---------------------------------|
| | Green, Slow Blink | Software disabled this port. |
| | Green, Steady | The link is operating normally. |
| | Off | No link exists. |

 **Note:**

If you connect two ports explicitly set for different speeds (for example one configured as 10BaseT and the other as 100BaseTX) the port link LED may indicate a link, but the switch does not establish a link. Connect ports using the same set speed or use auto-negotiation on each switch.

Chapter 5: Translations of safety messages

 **Caution:**

When you mount this device in a rack, do not stack units directly on top of one another. You must secure each unit to the rack with appropriate mounting brackets. Mounting brackets cannot support multiple units.

 **Important:**

Achtung:

Wenn diese Einheit in einem Rack montiert wird, muß ein gewisser Abstand zur nächsten Einheit gelassen werden. Jede Einheit muß mit geeignetem Befestigungsmaterial gesichert werden. Das Befestigungsmaterial ist nicht für die gleichzeitige Befestigung mehrerer Einheiten geeignet.

 **Important:**

Si vous installez le module dans une baie, ne l'empilez pas directement sur un autre. Chaque module doit être fixé à sa propre baie à l'aide des supports de montage appropriés. Ces supports ne sont pas conçus pour résister à plusieurs modules.

 **Important:**

Precaución:

Cuando monte este dispositivo en un bastidor, no apile las unidades directamente una encima de otra. Cada unidad debe fijarse en el bastidor con las abrazaderas de montaje adecuadas. Las abrazaderas de montaje no están diseñadas para sostener varias unidades.

 **Important:**

Se il dispositivo viene installato in un rack, non impilare le unità direttamente una sull'altra. Ogni unità deve essere fissata al rack con le staffe di montaggio appropriate. Le staffe di montaggio non sono state progettate per supportare più unità.



警告: 在机架中安装此设备时, 请勿将多个部件叠放在机架中。必须用合适的安装托架将各个部件固定在机架中。安装托架无法支撑多个部件。



注意: この装置をラックに設置する場合は、ラック内のコネクタを直接積み重ねないようにしてください。各ユニットは専用の取り付けブラケットでラックに固定する必要があります。取り付けブラケットは複数のユニットを支えるようには設計されていません。



注意：在機箱中掛載此裝置時，請不要直接在機箱中的另一個裝置上直接堆放裝置。每一裝置都必須使用適當的掛載托架以固定在機架中。掛載托架不能用來支撐多個裝置。



Caution:

If you are not installing a module in the slot, be sure to keep the metal cover plate in place over the slot. Removing the cover plate impedes airflow and proper cooling of the unit.



Important:

Achtung:

Wenn Sie kein Modul im Schacht verwenden, muß die Metallabdeckung über dem Schacht montiert sein. Eine Entfernung der Abdeckung führt zu einer Verschlechterung der Luftzirkulation und damit zu einer nicht ausreichenden Kühlung der Einheit.



Important:

Si vous n'installez pas le module dans une baie, veillez à laisser la plaque métallique sur la baie. Si vous la retirez, l'aération du module ne peut pas s'effectuer correctement.



Important:

Precaution:

Si no instala ningún módulo en la ranura, asegúrese de mantener la placa de la cubierta de metal en la misma. Si la retira, impedirá que el aire circule y la unidad se refrigere adecuadamente.



Important:

Attenzione:

Se nello slot non vengono installati moduli, assicurarsi di mantenere la piastra di copertura metallica in sede sopra lo slot. La rimozione della piastra impedisce la ventilazione e il corretto raffreddamento dell'unità.



注意：この装置をラックに設置する場合は、ラック内のユニットを直接積み重ねないようにしてください。各ユニットは専用の取り付けブラケットでラックに固定する必要があります。取り付けブラケットは複数のユニットを支えるようには設計されていません。



注意：スロットにモジュールを取り付けない場合は、スロットにある金属製のカバープレートが外れないように注意してください。カバープレートを動かすと気流が妨げられ、適切なユニット冷却が行われなくなります。



注意：如果您未在插槽中安裝模組，請確定金屬殼板正確地蓋在插槽上。移除殼板會阻礙空氣流通以及裝置的適當冷卻度。



警告：如果您不打算在该插槽中安装任何模块，请务必使金属盖板正确地盖住该插槽。如果取下盖板，将妨碍通风及部件散热。



警告：この装置の電源は、電源コードを抜かない限り切断できません。緊急の場合にすばやく安全に切断できる場所に電源コードを接続してください。



警告：若要關閉此裝置的電源，拔掉插頭是唯一的方法。爲了因應緊急狀況，請將電源線連接到可以快速插拔的地方。

 **Warning:**

Disconnecting the AC power cord is the only way to turn off AC power to this device. Always connect the AC power cord in a quickly and safely accessible location in case of an emergency.

 **Important:**

Warnung:

Das Gerät kann nur durch Ziehen des Netzsteckers ausgeschaltet werden. Schließen Sie das Netzkabel an einer Steckdose an, die in Notfällen schnell und sicher zugänglich ist.

 **Important:**

Avertissement:

Pour mettre le module hors tension, vous devez impérativement déconnecter le cordon d'alimentation. En outre, vous devez dégager un espace minimal dans la zone de câblage pour pouvoir y accéder facilement en cas d'urgence.



警告：断开交流电源线是切断本设备的交流电源的唯一方法。交流电源线一定要连接到在紧急时刻可以快速安全地接触到的位置。

 **Important:**

Advertencia:

Para apagar el dispositivo debe desenchufar el cable. Conecte siempre el cable de alimentación a una toma segura y de fácil acceso por si se produjera alguna situación de emergencia.

 **Important:**

Avviso:

L'unico modo per disattivare questo dispositivo consiste nello scollegare il cavo di alimentazione. Collegare sempre il cavo di alimentazione ad una presa che sia facilmente e rapidamente accessibile in caso di emergenza.



Danger:

Use only power cords that have a grounding path. Without a proper ground, a person who touches the switch is in danger of receiving an electrical shock. Lack of a grounding path to the switch can result in excessive emissions.

! Important:

Vorsicht:

Verwenden Sie nur Netzkabel mit Schutzerdung. Ohne ordnungsgemäße Schutzerdung besteht für Personen, die den Switch berühren, die Gefahr eines elektrischen Schlages. Eine nichtvorhandene Schutzerdung kann zu sehr starken Abstrahlungen führen.

⚠ Danger:

N'utilisez que des cordons d'alimentation équipés de trajet de mise à la terre. Sans mise à la terre adaptée, vous risquez de recevoir une décharge électrique en touchant le commutateur. Par ailleurs, l'absence de trajet de mise à la terre peut générer des émissions excessives.

! Important:

Peligro:

Utilice únicamente cables de alimentación con toma de tierra. De lo contrario, al tocar el interruptor puede recibir una descarga eléctrica. Si no hay un circuito de toma de tierra en el enchufe, puede producirse un exceso de emisiones.

! Important:

Pericolo:

Utilizzare esclusivamente cavi di alimentazione dotati di un percorso per la messa a terra. Senza un'adeguata messa a terra, chiunque tocchi lo switch corre il rischio di ricevere una scossa elettrica. L'assenza di un percorso per la messa a terra verso lo switch può comportare un eccesso di emissioni.



危険: 接地経路を持つ電源コードを必ず使用するようになしてください。適切な接地がない状態でスイッチに触ると、感電する危険性があります。また、スイッチへの接地経路がないと、過度な放電を引き起こす可能性があります。



危险: 请仅使用接地的电源线。如果电源线不接地或接地不当, 接触交换机的可能受到电击。如果交换机不接地, 则可能导致放电过量。

⚠ Warning:

The lithium battery is not field replaceable. It must only be removed and replaced by authorized personnel. Contact Avaya Technical Support for assistance if the battery requires replacement.

! Important:

Warnung:

Die Lithiumbatterie kann nicht vor Ort ausgetauscht werden. Die Batterie darf nur von entsprechend befugtem Personal entfernt und ausgetauscht werden. Muss die Batterie ersetzt werden, wenden Sie sich bitte an den Technischen Support von Avaya.

! Important:

Avertissement:

La batterie au lithium n'est pas remplaçable sur site. Elle ne peut être enlevée et remplacée que par du personnel qualifié. Veuillez prendre contact avec le support technique d'Avaya si la batterie doit être remplacée.

! Important:

警告:

□□池不支持□□更□，只有授□人□才能□行拆卸和更□。如果您需要更□□池，□□系 Avaya 技□支持部□□求帮助。

! Important:

Advertencia:

La batería de litio no puede sustituirse en campo. La extracción y sustitución debe ser realizada exclusivamente por personal autorizado. Comuníquese con el Soporte técnico de Avaya si necesita asistencia para cambiar la batería.

! Important:

Aviso:

A bateria de lítio não é substituível em campo. Só deve ser removida e substituída por pessoal autorizado. Entre em contato com o Suporte Técnico da Avaya para obter assistência, se a bateria precisar de substituição.

! Important:

Предупреждение:

Литиевые аккумуляторы не подлежат самостоятельной замене в условиях эксплуатации. Их может извлекать и заменять только аттестованный персонал. Если требуется замена аккумулятора, обратитесь в службу технической поддержки Avaya.

