



Installing the Avaya Virtual Services Platform 8000 Series

Release 4.2.1
NN47277-300
Issue 05.02
July 2015

© 2015 Avaya Inc.
All Rights Reserved.

Notice

While reasonable efforts have been made to ensure that the information in this document is complete and accurate at the time of printing, Avaya assumes no liability for any errors. Avaya reserves the right to make changes and corrections to the information in this document without the obligation to notify any person or organization of such changes.

Documentation disclaimer

"Documentation" means information published by Avaya in varying mediums which may include product information, operating instructions and performance specifications that Avaya may generally make available to users of its products and Hosted Services. Documentation does not include marketing materials. Avaya shall not be responsible for any modifications, additions, or deletions to the original published version of documentation unless such modifications, additions, or deletions were performed by Avaya. End User agrees to indemnify and hold harmless Avaya, Avaya's agents, servants and employees against all claims, lawsuits, demands and judgments arising out of, or in connection with, subsequent modifications, additions or deletions to this documentation, to the extent made by End User.

Link disclaimer

Avaya is not responsible for the contents or reliability of any linked websites referenced within this site or documentation provided by Avaya. Avaya is not responsible for the accuracy of any information, statement or content provided on these sites and does not necessarily endorse the products, services, or information described or offered within them. Avaya does not guarantee that these links will work all the time and has no control over the availability of the linked pages.

Warranty

Avaya provides a limited warranty on Avaya hardware and software. Refer to your sales agreement to establish the terms of the limited warranty. In addition, Avaya's standard warranty language, as well as information regarding support for this product while under warranty is available to Avaya customers and other parties through the Avaya Support website: <http://support.avaya.com> or such successor site as designated by Avaya. Please note that if You acquired the product(s) from an authorized Avaya Channel Partner outside of the United States and Canada, the warranty is provided to You by said Avaya Channel Partner and not by Avaya.

Licenses

THE SOFTWARE LICENSE TERMS AVAILABLE ON THE AVAYA WEBSITE, [HTTP://SUPPORT.AVAYA.COM/LICENSEINFO](http://support.avaya.com/licenseinfo) OR SUCH SUCCESSOR SITE AS DESIGNATED BY AVAYA, ARE APPLICABLE TO ANYONE WHO DOWNLOADS, USES AND/OR INSTALLS AVAYA SOFTWARE, PURCHASED FROM AVAYA INC., ANY AVAYA AFFILIATE, OR AN AVAYA CHANNEL PARTNER (AS APPLICABLE) UNDER A COMMERCIAL AGREEMENT WITH AVAYA OR AN AVAYA CHANNEL PARTNER. UNLESS OTHERWISE AGREED TO BY AVAYA IN WRITING, AVAYA DOES NOT EXTEND THIS LICENSE IF THE SOFTWARE WAS OBTAINED FROM ANYONE OTHER THAN AVAYA, AN AVAYA AFFILIATE OR AN AVAYA CHANNEL PARTNER; AVAYA RESERVES THE RIGHT TO TAKE LEGAL ACTION AGAINST YOU AND ANYONE ELSE USING OR SELLING THE SOFTWARE WITHOUT A LICENSE. BY INSTALLING, DOWNLOADING OR USING THE SOFTWARE, OR AUTHORIZING OTHERS TO DO SO, YOU, ON BEHALF OF YOURSELF AND THE ENTITY FOR WHOM YOU ARE INSTALLING, DOWNLOADING OR USING THE SOFTWARE (HEREINAFTER REFERRED TO INTERCHANGEABLY AS "YOU" AND "END USER"), AGREE TO THESE TERMS AND CONDITIONS AND CREATE A BINDING CONTRACT BETWEEN YOU AND AVAYA INC. OR THE APPLICABLE AVAYA AFFILIATE ("AVAYA").

Avaya grants You a license within the scope of the license types described below, with the exception of Heritage Nortel Software, for which the scope of the license is detailed below. Where the order documentation does not expressly identify a license type, the applicable license will be a Designated System License. The

applicable number of licenses and units of capacity for which the license is granted will be one (1), unless a different number of licenses or units of capacity is specified in the documentation or other materials available to You. "Software" means computer programs in object code, provided by Avaya or an Avaya Channel Partner, whether as stand-alone products, pre-installed on hardware products, and any upgrades, updates, patches, bug fixes, or modified versions thereto. "Designated Processor" means a single stand-alone computing device. "Server" means a Designated Processor that hosts a software application to be accessed by multiple users. "Instance" means a single copy of the Software executing at a particular time: (i) on one physical machine; or (ii) on one deployed software virtual machine ("VM") or similar deployment.

Licence types

Designated System(s) License (DS). End User may install and use each copy or an Instance of the Software only on a number of Designated Processors up to the number indicated in the order. Avaya may require the Designated Processor(s) to be identified in the order by type, serial number, feature key, Instance, location or other specific designation, or to be provided by End User to Avaya through electronic means established by Avaya specifically for this purpose.

Heritage Nortel Software

"Heritage Nortel Software" means the software that was acquired by Avaya as part of its purchase of the Nortel Enterprise Solutions Business in December 2009. The Heritage Nortel Software currently available for license from Avaya is the software contained within the list of Heritage Nortel Products located at <http://support.avaya.com/LicenseInfo> under the link "Heritage Nortel Products" or such successor site as designated by Avaya. For Heritage Nortel Software, Avaya grants You a license to use Heritage Nortel Software provided hereunder solely to the extent of the authorized activation or authorized usage level, solely for the purpose specified in the Documentation, and solely as embedded in, for execution on, or for communication with Avaya equipment. Charges for Heritage Nortel Software may be based on extent of activation or use authorized as specified in an order or invoice.

Copyright

Except where expressly stated otherwise, no use should be made of materials on this site, the Documentation, Software, Hosted Service, or hardware provided by Avaya. All content on this site, the documentation, Hosted Service, and the product provided by Avaya including the selection, arrangement and design of the content is owned either by Avaya or its licensors and is protected by copyright and other intellectual property laws including the sui generis rights relating to the protection of databases. You may not modify, copy, reproduce, republish, upload, post, transmit or distribute in any way any content, in whole or in part, including any code and software unless expressly authorized by Avaya. Unauthorized reproduction, transmission, dissemination, storage, and or use without the express written consent of Avaya can be a criminal, as well as a civil offense under the applicable law.

Third Party Components

"Third Party Components" mean certain software programs or portions thereof included in the Software or Hosted Service may contain software (including open source software) distributed under third party agreements ("Third Party Components"), which contain terms regarding the rights to use certain portions of the Software ("Third Party Terms"). As required, information regarding distributed Linux OS source code (for those products that have distributed Linux OS source code) and identifying the copyright holders of the Third Party Components and the Third Party Terms that apply is available in the products, Documentation or on Avaya's website at: <http://support.avaya.com/Copyright> or such successor site as designated by Avaya. You agree to the Third Party Terms for any such Third Party Components.

Preventing Toll Fraud

"Toll Fraud" is the unauthorized use of your telecommunications system by an unauthorized party (for example, a person who is not a corporate employee, agent, subcontractor, or is not working on your company's behalf). Be aware that there can be a risk of Toll Fraud associated with your system and that, if Toll Fraud occurs, it can

result in substantial additional charges for your telecommunications services.

Avaya Toll Fraud intervention

If You suspect that You are being victimized by Toll Fraud and You need technical assistance or support, call Technical Service Center Toll Fraud Intervention Hotline at +1-800-643-2353 for the United States and Canada. For additional support telephone numbers, see the Avaya Support website: <http://support.avaya.com> or such successor site as designated by Avaya. Suspected security vulnerabilities with Avaya products should be reported to Avaya by sending mail to: securityalerts@avaya.com.

Downloading Documentation

For the most current versions of Documentation, see the Avaya Support website: <http://support.avaya.com>, or such successor site as designated by Avaya.

Contact Avaya Support

See the Avaya Support website: <http://support.avaya.com> for product or Hosted Service notices and articles, or to report a problem with your Avaya product or Hosted Service. For a list of support telephone numbers and contact addresses, go to the Avaya Support website: <http://support.avaya.com> (or such successor site as designated by Avaya), scroll to the bottom of the page, and select Contact Avaya Support.

Trademarks

The trademarks, logos and service marks ("Marks") displayed in this site, the Documentation, Hosted Service(s), and product(s) provided by Avaya are the registered or unregistered Marks of Avaya, its affiliates, or other third parties. Users are not permitted to use such Marks without prior written consent from Avaya or such third party which may own the Mark. Nothing contained in this site, the Documentation, Hosted Service(s) and product(s) should be construed as granting, by implication, estoppel, or otherwise, any license or right in and to the Marks without the express written permission of Avaya or the applicable third party.

Avaya is a registered trademark of Avaya Inc.

All non-Avaya trademarks are the property of their respective owners. Linux[®] is the registered trademark of Linus Torvalds in the U.S. and other countries.

Contents

Chapter 1: Introduction	6
Purpose.....	6
Related resources.....	6
Documentation.....	6
Training.....	6
Subscribing to e-notifications.....	7
Support.....	9
Searching a documentation collection.....	9
Chapter 2: New in this release	11
VOSS 4.2.1.....	11
Features.....	11
Other changes.....	11
VOSS 4.2.....	12
Features.....	12
Other changes.....	13
Chapter 3: Hardware models for VSP 8000 Series	14
Chapter 4: Preinstallation checklist	19
Chapter 5: Installing the Avaya Virtual Services Platform 8000 Series	21
Installation checklist.....	21
Installation fundamentals.....	22
Ethernet Switch Module.....	25
Installing an Ethernet Switch Module.....	26
Hot swap of VSP 8400 Ethernet Switch Module.....	29
40G channelization.....	30
Electrostatic discharge.....	30
Technical specifications.....	32
Package contents.....	33
Installing the VSP 8000 Series in an equipment rack.....	34
Using the optional slide rack mount kit.....	35
Using the supplied brackets.....	51
Cable requirements for the VSP 8000 Series.....	53
Installation and removal of transceivers.....	54
Console port pin assignments.....	55
AC power supply.....	55
Installing an AC power supply.....	55
AC power supply specifications.....	57
AC power cord specifications.....	58
DC power supply.....	59
Installing a DC power supply.....	59

DC power supply specifications.....	62
Removing a power supply.....	63
Airflow direction.....	64
Installing a fan tray.....	64
LED state definitions.....	66
Switch LEDs.....	66
Management port LED state indicators.....	67
SFP, SFP+, and QSFP+ port LED state indicators.....	67
Port LED state indicators.....	68
Channelized LED state indicators.....	69
Enterprise Device Manager (EDM) representation of physical LED status.....	70
40GBASE-QSFP+ ports.....	70
Chapter 6: Translations of safety messages.....	71

Chapter 1: Introduction

Purpose

This guide provides information and instructions to install Avaya Virtual Services Platform 8000 Series switches.

This document is renamed to *Installing the Avaya Virtual Services Platform 8000 Series*, NN47227-300. Avaya Virtual Services Platform 8000 Series includes Avaya Virtual Services Platform 8200 and Avaya Virtual Services Platform 8400.

Related resources

Documentation

See the *Documentation Reference for Avaya Virtual Services Platform 7200 Series and 8000 Series*, NN47227-100 for a list of the documentation for this product.

Training

Ongoing product training is available. For more information or to register, you can access the Web site at <http://avaya-learning.com/>.

Viewing Avaya Mentor videos

Avaya Mentor videos provide technical content on how to install, configure, and troubleshoot Avaya products.

About this task

Videos are available on the Avaya Support website, listed under the video document type, and on the Avaya-run channel on YouTube.

Procedure

- To find videos on the Avaya Support website, go to <http://support.avaya.com> and perform one of the following actions:
 - In **Search**, type `Avaya Mentor Videos` to see a list of the available videos.
 - In **Search**, type the product name. On the Search Results page, select **Video** in the **Content Type** column on the left.
- To find the Avaya Mentor videos on YouTube, go to www.youtube.com/AvayaMentor and perform one of the following actions:
 - Enter a key word or key words in the **Search Channel** to search for a specific product or topic.
 - Scroll down Playlists, and click the name of a topic to see the available list of videos posted on the website.

 **Note:**

Videos are not available for all products.

Subscribing to e-notifications

Subscribe to e-notifications to receive an email notification when documents are added to or changed on the Avaya Support website.

About this task

You can subscribe to different types of general notifications, for example, Product Correction Notices (PCN), which apply to any product or a specific product. You can also subscribe to specific types of documentation for a specific product, for example, Application & Technical Notes for Ethernet Routing Switch 8800.

Procedure

1. In an Internet browser, go to <https://support.avaya.com>.
2. Type your username and password, and then click **Login**.
3. Under **My Information**, select **SSO login Profile**.
4. Click **E-NOTIFICATIONS**.
5. In the GENERAL NOTIFICATIONS area, select the required documentation types, and then click **UPDATE**.

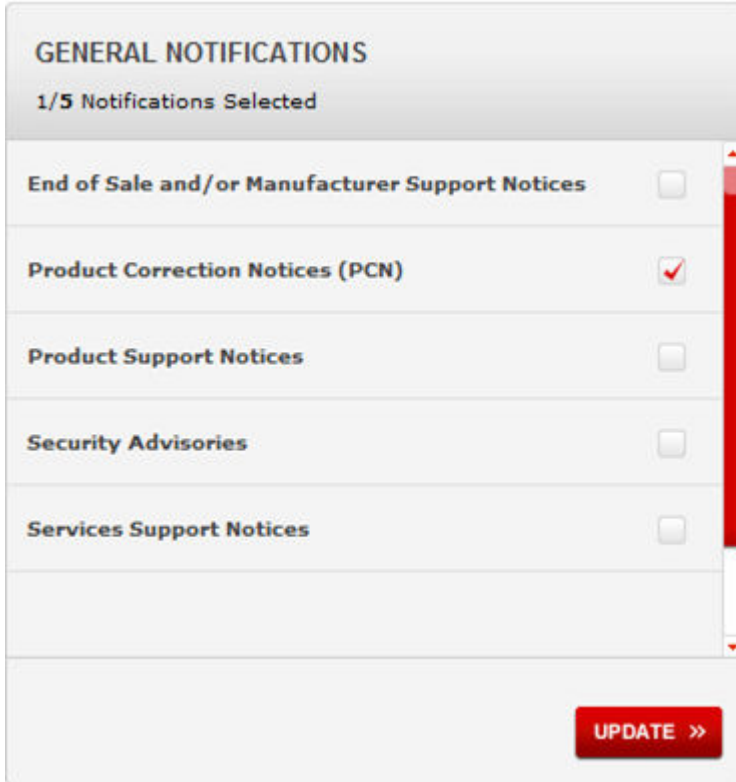

6. Click **OK**.
7. In the **PRODUCT NOTIFICATIONS** area, click **Add More Products**.

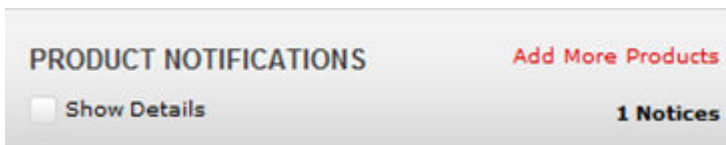

8. Scroll through the list, and then select the product name.
9. Select a release version.
10. Select the check box next to the required documentation types.

The screenshot shows two side-by-side panels. The left panel, titled 'PRODUCTS', has a 'My Notifications' link in the top right. It contains a list of products: Virtual Services Platform 7000, Virtualization Provisioning Service, Visual Messenger™ for OCTEL® 250/350, Visual Vectors, Visualization Performance and Fault Manager, Voice Portal, Voice over IP Monitoring, W310 Wireless LAN Gateway, WLAN 2200 Series, and WLAN Handset 2200 Series. The right panel is titled 'VIRTUAL SERVICES PLATFORM 7000' and features a 'Select a Release Version' dropdown menu set to 'All and Future'. Below this are several checkboxes for documentation categories: Administration and System Programming, Application Developer Information, Application Notes, Application and Technical Notes (checked), Declarations of Conformity, and Documentation Library (checked). A red 'SUBMIT >>' button is located at the bottom right of the right panel.

11. Click **Submit**.

Support

Go to the Avaya Support website at <http://support.avaya.com> for the most up-to-date documentation, product notices, and knowledge articles. You can also search for release notes, downloads, and resolutions to issues. Use the online service request system to create a service request. Chat with live agents to get answers to questions, or request an agent to connect you to a support team if an issue requires additional expertise.

Searching a documentation collection

On the Avaya Support website, you can download the documentation library for a specific product and software release to perform searches across an entire document collection. For example, you can perform a single, simultaneous search across the collection to quickly find all occurrences of a particular feature. Use this procedure to perform an index search of your documentation collection.

Before you begin

- Download the documentation collection zip file to your local computer.
- You must have Adobe Acrobat or Adobe Reader installed on your computer.

Procedure

1. Extract the document collection zip file into a folder.
2. Navigate to the folder that contains the extracted files and open the file named `<product_name_release>.pdx`.

3. In the Search dialog box, select the option **In the index named <product_name_release>.pdx**.
4. Enter a search word or phrase.
5. Select any of the following to narrow your search:
 - Whole Words Only
 - Case-Sensitive
 - Include Bookmarks
 - Include Comments
6. Click **Search**.

The search results show the number of documents and instances found. You can sort the search results by Relevance Ranking, Date Modified, Filename, or Location. The default is Relevance Ranking.

Chapter 2: New in this release

The following sections detail what is new in *Installing the Avaya Virtual Services Platform 8000 Series*, NN47227-300.

VOSS 4.2.1

Features

There are no feature-related changes for Release 4.2.1.

Other changes

See the following sections about the changes that are not feature related.

Hardware models

Updated this section with VSP 8400 hardware details.

For more information, see [Hardware models for VSP 8000 Series](#) on page 14.

Airflow direction

Added information about the airflow direction for the VSP 8000 series hardware.

For more information, see [Airflow direction](#) on page 64.

40GBASE-QSFP+ ports

Added information about 40GBASE-QSFP+ ports.

For more information, see [40GBASE-QSFP+ ports](#) on page 70.

VOSS 4.2

Features

See the following sections for information about feature changes.

VSP 8400

VSP 8400 is a flexible, compact form-factor ethernet switch that features four expansion slots for 8400 series Ethernet Switch Modules (ESMs).

Ethernet Switch Module (ESM)

Ethernet Switch Module (ESM) provides physical interfaces on the VSP 8400 series. There are four Ethernet Switch Modules (ESMs):

- 8424XS – 24-port 10GBASE-SFP+ Ethernet Switch Module
- 8424XT – 24-port 10GBASE-T Ethernet Switch Module
- 8408QQ – 8-port 40GBASE-QSFP+ Ethernet Switch Module
- 8418XSQ – 16-port 10GBASE-SFP+ and 2-port 40GBASE-QSFP+ Combination Ethernet Switch Module

For more information, see [Ethernet Switch Module](#) on page 25.

Installing an Ethernet Switch Module (ESM)

Install an ESM to replace an existing module or to add new capability.

For more information, see [Installing an Ethernet Switch Module](#) on page 26.

Note:

This feature is available only in VSP 8400.

Hot swap of VSP 8400 Ethernet Switch Module

The VSP 8400 supports hot swapping ESMs to install, remove or replace system components without having to shutdown the system.

For more information, see [Hot swap of VSP 8400 Ethernet Switch Module](#) on page 29.

40G channelization

Channelization allows you to configure 40Gbps QSFP+ ports to operate as four 10 Gigabit Ethernet ports.

For more information, see [40G channelization](#) on page 30.

Port LED state indicators

This section describes Port LED state indicator changes.

For more information, see [Port LED state indicators](#) on page 68.

LED state indicators when Channelization is enabled

This section describes Channelized LED state indicators.

For more information, see [Channelized LED state indicators](#) on page 69.

EDM representation of physical LED status

This section describes the EDM representation of physical LED status.

For more information, see [Enterprise Device Manager \(EDM\) representation of physical LED status](#) on page 70.

Other changes

See the following sections about the changes that are not feature related.

Hardware models

Updated this section with VSP 8400 hardware details.

For more information, see [Hardware models for VSP 8000 Series](#) on page 14.

Installing the Avaya Virtual Services Platform 8000 Series

Updated installation fundamentals section with VSP 8400 hardware details, illustration, and part numbers.

For more information, see [Installation fundamentals](#) on page 22.

SFP, SFP+, and QSFP+ port LED state indicators

Created sections for SFP, SFP+ port LED state indicators and QSFP+ port LED state indicators.

For more information, see [SFP port LEDs](#) on page 67.

VSP 8400 hardware

Created a new table for VSP 8400 ESMs.

For more information, see [Installing the Avaya Virtual Services 8000 Series](#) on page 21.

Technical specifications

Updated the section with VSP 8400 specifications in physical specifications table.

For more information, see [Technical specifications](#) on page 32.

Package contents

Updated VSP 8400 power cord details.

For more information, see [Package contents](#) on page 33.

Checklists

[Preinstallation checklist](#) on page 19 and [Installation checklist](#) on page 21 are added to the document. You can print these checklists to aid in your installation process.

Chapter 3: Hardware models for VSP 8000 Series

This section lists the VSP 8000 Series hardware.

VSP 8200 hardware

Table 1: VSP 8284XSQ Hardware

VSP 8284XSQ	Description	Part number
<p>VSP 8284XSQ-AC</p> <p>This model number ships with one field-replaceable 800 watt AC power supply.</p>	<ul style="list-style-type: none"> • 80 ports of 10GBASE-SFP+ • 4 ports of 40GBASE-QSFP+ • one 10/100/1000BASE-T Out-Of-Band Management Port • one RJ-45 Console Port (10101) • one USB port • Base Software License • four field-replaceable fan modules 	<p>EC8200x01-E6</p> <p> Note:</p> <p>Replace the “x” with a country-specific power cord code. See the footnote for details.</p>
<p>VSP 8284XSQ-DC</p> <p>This model number ships with one field-replaceable 800 watt DC power supply.</p>	Includes all of the above features.	EC8200001-E6
<p>VSP 8284XSQ AC PS No PC GSA</p> <p>This model number is compliant with the Trade Agreements Act (TAA). It ships with one field-replaceable 800 watt AC power supply but no power cord.</p>	Includes all of the above features.	EC8200A01-E6GS
<p>VSP 8284XSQ AC PS NA PC GSA</p> <p>This model number is also TAA compliant and ships with an AC power supply. However, it</p>	Includes all of the above features.	EC8200E01-E6GS

Table continues...

VSP 8284XSQ	Description	Part number
includes a North American power cord.		
Redundant power supplies		
800 watt AC redundant power supply	<ul style="list-style-type: none"> The VSP 8284XSQ comes with one 800 W AC PSU. For full power redundancy, you can install a second 800 W AC PSU. 	EC8005x01-E6 * Note: Replace the “x” with a country-specific power cord code. See the footnote for details.
800 watt DC redundant power supply	<ul style="list-style-type: none"> The VSP 8284XSQ comes with one 800 W DC PSU. For full power redundancy, you can install a second 800 W DC PSU. 	EC8005001-E6
<p>*Note: The character (x) in the order number indicates the power cord code. Replace the “x” with the proper letter to indicate desired product nationalization. See the following for details:</p> <p>“A”: No power cord included.</p> <p>“B”: Includes European “Schuko” power cord common in Austria, Belgium, Finland, France, Germany, The Netherlands, Norway, and Sweden.</p> <p>“C”: Includes power cord commonly used in the United Kingdom and Ireland.</p> <p>“D”: Includes power cord commonly used in Japan.</p> <p>“E”: Includes North American power cord.</p> <p>“F”: Includes Australian power cord.</p>		
Redundant fan modules		
12 volt redundant fan module	The VSP 8284XSQ comes with all four 12–V fan modules installed.	EC8011004-E6
Universal Slide Rack Mount Kit (300mm-900mm)		
Slide Rack Mount Kit (300mm-900mm)	The optional rack mount kit allows a switch to be installed in a four post rack with depths between 300mm and 900mm. It is designed for use on the VSP 7200, VSP 8200 and VSP 8400.	EC8011002-E6
<p>* Note:</p> <p>The universal slide rack mount kit is optional and must be ordered separately. VSP 7200, VSP 8200 and VSP 8400 ship with rack mount brackets. When using rack mount brackets on VSP 8200 and VSP 8400, Avaya recommends the use of a shelf to provide additional support.</p>		

VSP 8400 hardware

The following tables describe the VSP 8404 hardware.

Table 2: VSP 8404 Hardware

VSP 8404	Description	Part number
<p>VSP 8404–AC</p> <p>This model number ships with one field-replaceable 800 watt AC power supply.</p>	<ul style="list-style-type: none"> • one 10/100/1000BASE-T Out-Of-Band Management Port • one RJ-45 Console Port • one USB port • Base Software License • four field-replaceable fan modules • No power cord 	<p>EC8400x01-E6</p> <p> Note: Replace the “x” with a country-specific power cord code. See the footnote for details.</p>
<p>VSP 8404 AC PS No PC GSA</p> <p>This model number is compliant with the Trade Agreements Act (TAA). It ships with one field-replaceable 800 watt AC power supply but no power cord.</p>	Includes all of the above components.	EC8400A01-E6GS
<p>VSP8404 AC PS NA PC GSA</p> <p>This model number is also TAA compliant and ships with an AC power supply. However, it includes a North American power cord.</p>	Includes all of the above components.	EC8400E01-E6GS
<p>VSP 8404–DC</p> <p>This model number ships with one field replaceable 800 watt DC power supply.</p>	Includes all of the above components.	EC8400001-E6
Redundant power supplies		
800 watt AC redundant power supply	<ul style="list-style-type: none"> • The VSP 8404 comes with one 800 W AC PSU. • For full power redundancy, you can install a second 8001-AC-PSU. • No power cord. 	EC8005x01-E6
800 watt DC redundant power supply	<ul style="list-style-type: none"> • The VSP 8404 comes with one 800 W DC PSU. • For full power redundancy, you can install a second 800 W DC PSU. 	EC8005001-E6
<p>*Note: The character (x) in the order number indicates the power cord code. Replace the “x” with the proper letter to indicate desired product nationalization. See the following for details: “A”: No power cord included.</p>		

Table continues...

VSP 8404	Description	Part number
<p>“B”: Includes European “Schuko” power cord common in Austria, Belgium, Finland, France, Germany, The Netherlands, Norway, and Sweden.</p> <p>“C”: Includes power cord commonly used in the United Kingdom and Ireland.</p> <p>“D”: Includes power cord commonly used in Japan.</p> <p>“E”: Includes North American power cord.</p> <p>“F”: Includes Australian power cord.</p>		
Spare fan modules		
Spare fan module	The VSP 8404 comes with all four 12–V fan modules installed. This part can be purchased if a spare fan module is desired.	EC8011004-E6
Universal Slide Rack Mount Kit (300mm-900mm)		
Slide Rack Mount Kit (300mm-900mm)	The optional rack mount kit allows a switch to be installed in a four post rack with depths between 300mm and 900mm. It is designed for use on the VSP 7200, VSP 8200 and VSP 8400.	EC8011002-E6
<p>* Note:</p> <p>The universal slide rack mount kit is optional and must be ordered separately. VSP 7200, VSP 8200 and VSP 8400 ship with rack mount brackets. When using rack mount brackets on VSP 8200 and VSP 8400, Avaya recommends the use of a shelf to provide additional support.</p>		

Table 3: VSP 8400 Ethernet switch modules (ESMs)

Model Name	Description	Part Number
8424XS	24-port 10GBASE-SFP+ Ethernet Switch Module	EC8404001-E6
8424XS (TAA-compliant)	24-port 10GBASE-SFP+ Ethernet Switch Module	EC8404001-E6GS
8424XT	24-port 10GBASE-T Ethernet Switch Module	EC8404002-E6
8424XT (TAA-compliant)	24-port 10GBASE-T Ethernet Switch Module	EC8404002-E6GS
8408QQ	8-port* 40GBASE-QSFP+ Ethernet Switch Module	EC8404003-E6
8408QQ (TAA-compliant)	8-port* 40GBASE-QSFP+ Ethernet Switch Module	EC8404003-E6GS
8418XSQ	16-port 10GBASE-SFP+ and 2-port 40GBASE-QSFP+ Combo Ethernet Switch Module	EC8404005-E6
8418XSQ (TAA-compliant)	16-port 10GBASE-SFP+ and 2-port 40GBASE-QSFP+ Combo Ethernet Switch Module	EC8404005-E6GS
<p>* Note:</p> <p>* Two ports are reserved for future use.</p>		

Compatible transceivers

Important:

Avaya recommends using Avaya-branded SFP, SFP+, and QSFP+ transceivers as they have been through extensive qualification and testing. Avaya will not be responsible for issues related to non-Avaya branded transceivers.

- The VSP 8000 Series operates in forgiving mode for SFP transceivers, which means that the switch will bring up the port operationally when using non-Avaya SFP transceivers. Avaya does not provide support for operational issues related to these SFPs, but they will operate and the port link will come up. The switch logs the device as an unsupported or unknown device.
- The VSP 8000 Series operates in strict mode for SFP+ and QSFP+ transceivers, which means that the switch will not bring the port up operationally when using non-Avaya SFP+ or QSFP+ transceivers.
- The VSP 8000 Series operates in forgiving mode for SFP+ and QSFP+ direct attached cables, which means that the switch will bring up the port operationally when using Non-Avaya direct attached cables. Avaya does not provide support for operational issues related to these DACs, but they will operate and the port link will come up.

For more information about compatible transceivers, see *Installing Transceivers and Optical Components on Avaya Virtual Services Platform 7200 Series and 8000 Series*, NN47227-301.

Chapter 4: Preinstallation checklist

Before you install the Avaya Virtual Services Platform 8000 Series, make sure that you complete the tasks in the preinstallation checklist.

No.	Task	Description	✓
1.	Review the technical specification for the switch. Make sure that the area where you install the switch and where it will operate meet the requirements.	For the physical, electrical, and environmental specifications, see Technical specifications on page 32.	
2.	Verify the power supply unit (PSU) specifications. Optionally order a redundant PSU to provide redundancy and load sharing.	See AC power supply specifications on page 57 or DC power supply specifications on page 62.	
3.	Make sure that you have the following tools and cables: <ul style="list-style-type: none"> • Phillips #2 screwdriver • RJ-45 console port cable • ESD cable 	See Cable requirements for the VSP 8000 Series on page 53.	
4.	Unpack the equipment.	Observe ESD precautions when you unpack the equipment. See Electrostatic discharge on page 30	
5.	Verify the contents of the shipped package.	See Package contents on page 33 for a description of the components that are provided with the switch. If any components are missing, contact Avaya support at http://support.avaya.com/ .	
6.	Make sure that the power cord has the correct country-specific termination.		
7.	Prepare the rack.	Ensure that there is enough rack space to accommodate a 2RU switch (8.8 cm). Ensure that the rack is bolted to the floor and braced if necessary. Ensure that the rack is grounded to the same grounding electrode used by the power service in the area. The ground path must be	

Table continues...

Preinstallation checklist

No.	Task	Description	✓
		permanent and must not exceed 1 Ohm of resistance from the rack to the grounding electrode.	

Chapter 5: Installing the Avaya Virtual Services Platform 8000 Series

This section provides the information and procedures to install the Avaya Virtual Services Platform 8000 Series.

Installation checklist

Use this checklist to install the Avaya Virtual Services Platform 8000 Series.

No.	Task	Description	✓
1.	Mount the Avaya Virtual Services Platform 8000 Series in the equipment rack.	See Installing the VSP 8000 Series in an equipment rack on page 34. You have two options for installing the switch in an equipment rack: <ul style="list-style-type: none">• Using the optional slide rack mount kit on page 35• Using the supplied brackets on page 51	
2.	Install the primary or redundant power supply. ! Important: Avaya does not support a combination of AC-input and DC-input power supplies in the same chassis.	If you have an AC power supply, see Installing an AC power supply on page 55. If you have a DC power supply, see Installing a DC power supply on page 59.	
3.	For the VSP 8400, install an Ethernet Switch Module.	See Installing an Ethernet Switch Module on page 26.	
4.	Check the LEDs to verify the installation.	For a description of the LEDs, see LED state definitions on page 66.	

Installation fundamentals

VSP 8200

The VSP 8200 consists of:

- eighty 10GBASE-SFP/SFP+ ports
- four 40GBASE-QSFP+ ports
- one 10/100/1000BASE-T Out-Of-Band Management Port
- one RJ-45 Console Port
- one USB port
- Base Software License
- one field-replaceable 800 watt power supply (either AC or DC)
- four field-replaceable 12 volt fan trays

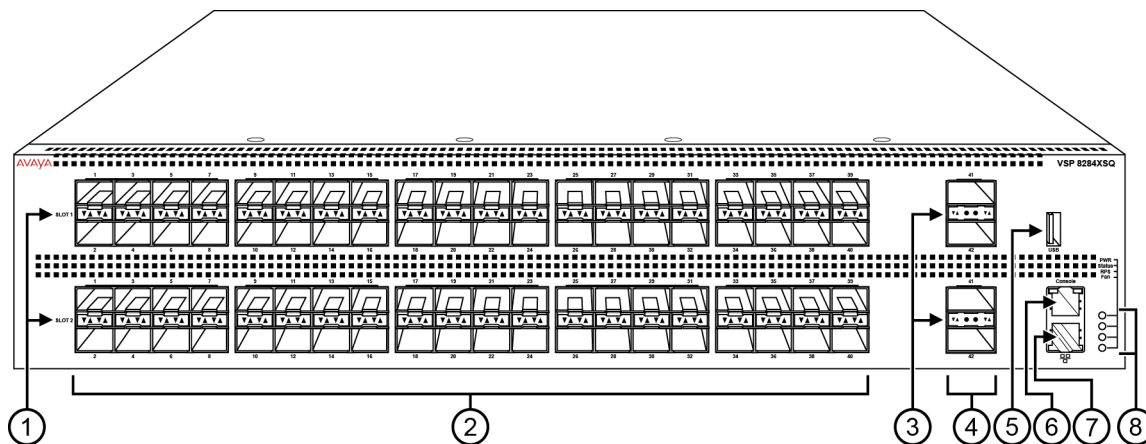

Figure 1: VSP 8284XSQ — Front view

1. SFP+ port LEDs are in between the ports on each slot. The up arrows refer to the port above and the down arrows refer to the port below. For a description of what the LEDs mean, see [SFP, SFP+, and QSFP+ port LED state indicators](#) on page 67.
2. Eighty SFP+ ports that support Avaya's 1G SFPs and 10G SFP+s.
 - 40 ports in Slot 1 on top
 - 40 ports in Slot 2 on the bottom
3. QSFP+ port LEDs are in between the ports on each slot. The up arrows refer to the port above and the down arrows refer to the port below. For a description of what the LEDs mean, see [SFP, SFP+, and QSFP+ port LED state indicators](#) on page 67.
4. Four QSFP+ ports: two in Slot 1 and two in Slot 2.
5. USB port
6. Console port (10101)

Table continues...

7. Management port — The LEDs are on the bottom of the port. For more information, see [Management port LEDs](#) on page 67.

8. LEDs for system power (PWR), switch status (Status), redundant power supply (RPS), and fan trays (Fan). For more information, see [Switch LEDs](#) on page 66.

The following figure shows the rear of the chassis with four fan trays and one power supply installed. The fan trays are numbered 1–4 from left to right, and the power supplies are numbered PSU 1 on top and PSU 2 on the bottom.

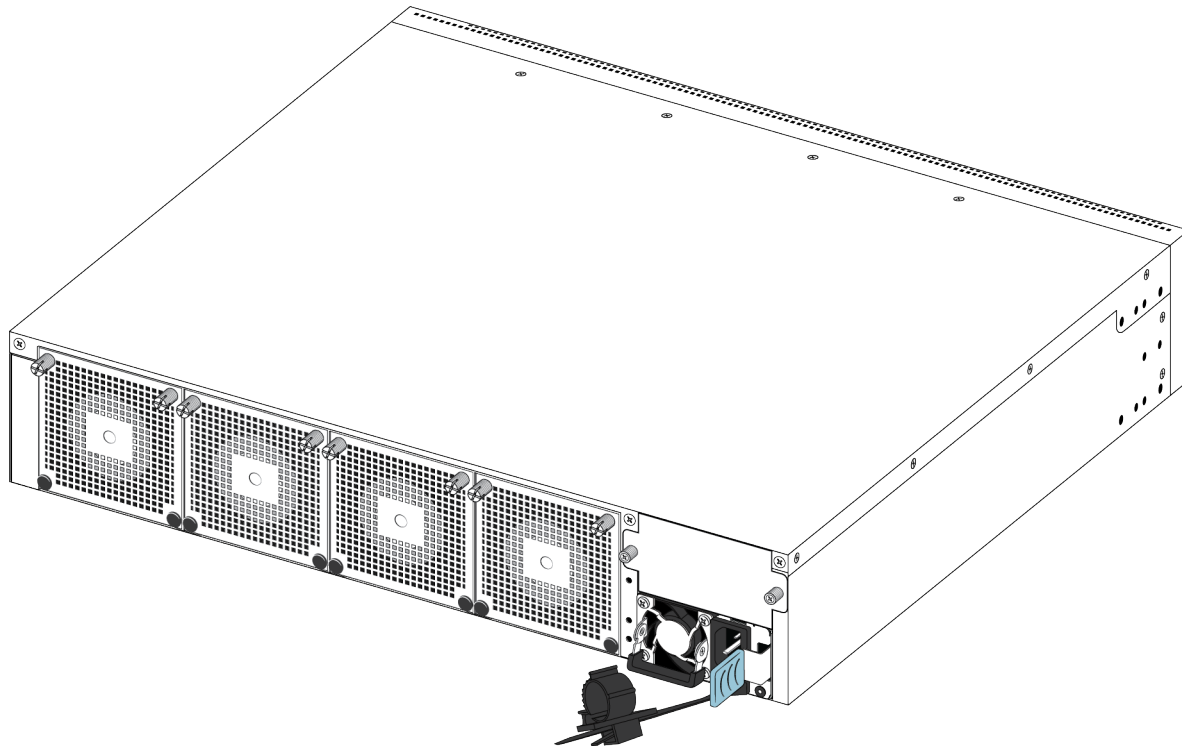

Figure 2: VSP 8284XSQ — Rear view

VSP 8400

The VSP 8400 consists of:

- four slots to install ESMs. For more information, see [Ethernet Switch Module \(ESM\)](#) on page 25
- one 10/100/1000BASE-T Out-of-Band Management port
- one RJ45 console port
- one USB port
- one field replaceable 800 watt power supply (AC or DC)
- four field replaceable 12 volt fan trays
- Base Software License

The following figure shows the front view of the VSP 8404.

*** Note:**

When looking at the front of the switch, slot numbering begins at the top row and increases from left to right. Slot 1 is the top-left slot; slot 2 is the top-right slot. Slot 3 is the bottom-left slot; slot 4 is the bottom-right slot.

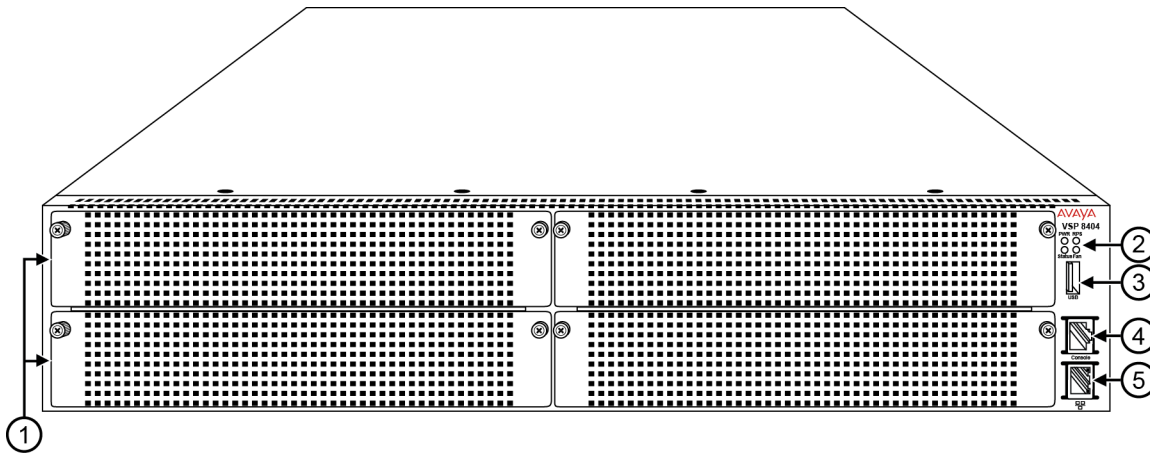

Figure 3: VSP 8404 Front view

1. Displays the four slots to install ESMs. For more information on ESMs supported in this current release, see [Ethernet Switch Module \(ESM\)](#) on page 25. The table below shows the part numbers for the ESMs:

ESM	Part number
1/10GBASE-SFP+	8424XS - EC8404001-E6 8424XS (GSA version)- EC8404001-E6GS
100M/1G/10GBASE-RJ45	8424XT - EC8404002-E6 8424XT (GSA Version) - EC8404002-E6GS
40GBASE-QSFP+	8408QQ - EC8404003-E6 8408QQ (GSA Version) - EC8404003-E6GS
1/10GBASE-SFP+ and 40GBASE-QSFP+ combination	8418XSQ - EC8404005-E6 8418XSQ (GSA Version) - EC8404005-E6GS

2. LEDs for system power (PWR), switch status (Status), redundant power supply (RPS), and fan trays (Fan).
3. USB port
4. Console port
5. OOB management port

Ethernet Switch Module

An Ethernet Switch Module (ESM) is a field replaceable expansion module that provides physical interfaces on the VSP 8400. The VSP 8400 provides four expansion slots.

The VSP 8400 supports the following ESMs.

8424XS

- 8424XS — EC8404001-E6 — provides 24 1/10G SFP+ ports.
- 8424XS (GSA version) — EC8404001-E6GS — provides 24 1/10G SFP+ ports.

Dimension	4.4cm – 1RU (H), 20.32cm (W), 29.21cm (D)
Weight	3.80 lbs = 1.72 kg
Power and thermal	93.32W (max) = 318.41 BTU/hr

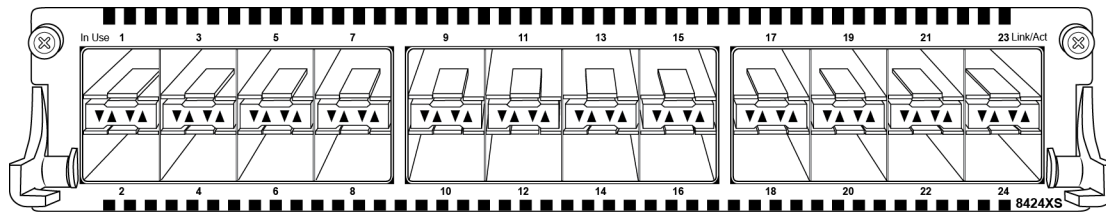

Figure 4: 8424XS

8424XT

- 8424XT — EC8404002-E6 — provides 24 100MB/1G/10G Copper ports.
- 8424XT (GSA version) — EC8404002-E6GS — 24 port 100MB/1G/10G Copper ports.

Dimension	4.4cm – 1RU (H), 20.32cm (W), 29.21cm (D)
Weight	4.05 lbs = 1.84 kg
Power and thermal	118.69W (max) = 404.97 BTU/hr

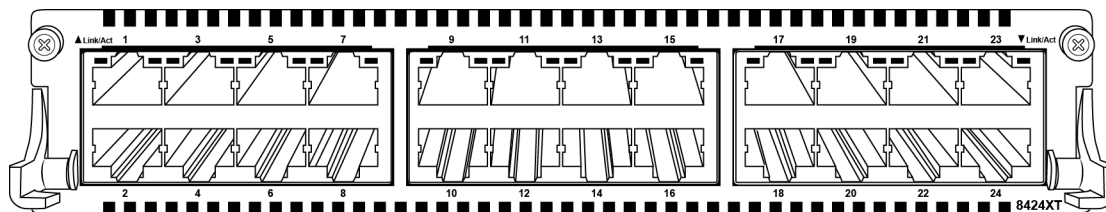

Figure 5: 8424XT

8408QQ

- 8408QQ — EC8404003-E6 — provides 8 40G QSFP+ ports.
- 8408QQ (GSA version) — EC8404003-E6GS — 8 40G QSFP+ ports.

Dimension	4.4cm – 1RU (H), 20.32cm (W), 29.21cm (D)
Weight	3.55 lbs = 1.61 kg
Power and thermal	88.64W (max) = 302.44 BTU/hr

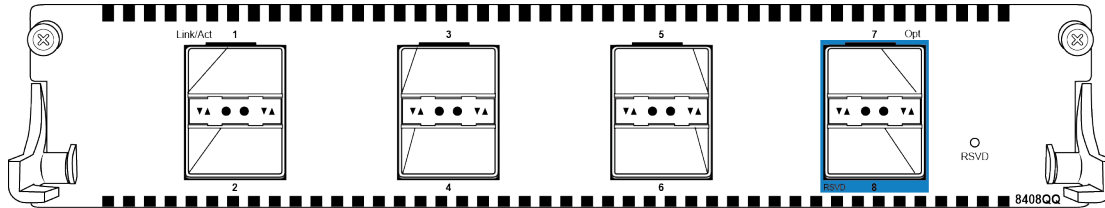

Figure 6: 8408QQ

*** Note:**

As shown in the above figure, ports 7 and 8 are reserved for future use.

8418XSQ

- 8418XSQ — EC8404005-E6 – 16 1/10G SFP+ and 2 40G QSFP+ ports.
- 8418XSQ (GSA version) — EC8404005-E6GS – 16 1/10G SFP+ and 2 40G QSFP+ ports.

Dimension	4.4cm – 1RU (H), 20.32cm (W), 29.21cm (D)
Weight	3.7 lbs = 1.68 kg
Power and thermal	86.89W (max) = 296.47 BTU/hr

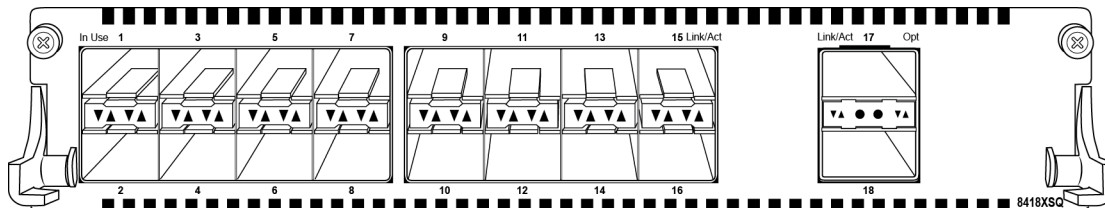

Figure 7: 8418XSQ

Installing an Ethernet Switch Module

Install an ESM to replace an existing module or to add new capability.

The switch has four bays and you can choose any one of them to install a module. The switch detects where the modules are installed so the order is not important.

You can also install a new module or hot swap an existing module while the switch is operational.

*** Note:**

When looking at the front of the switch, slot numbering begins at the top row and increases from left to right. Slot 1 is the top-left slot; slot 2 is the top-right slot. Slot 3 is the bottom-left slot; slot 4 is the bottom-right slot.

Before you begin

To prevent damage, handle the ESMs carefully by using the following guidelines:

- To prevent damage from electrostatic discharge, always wear an antistatic wrist strap connected to an ESD jack.
- Always place the modules on appropriate antistatic material.
- Support the module from underneath with two hands. Do not touch components or connector pins with your hand, or damage can result.
- Visually inspect the connectors for damage before you insert the module. If you insert a module with damaged connectors you will damage the switch.
- Do not stack modules one on top of the other when you move them.
- Do not leave bays open. Fill all bays with modules or module bay covers to maintain safety compliance, proper cooling, and EMI containment.
- Do not over tighten screws. Tighten until snug. Do not use a power tool to tighten screws.

Procedure

1. Remove the two screws that secure the module bay cover to the chassis. (Save the module bay cover for possible future use.)

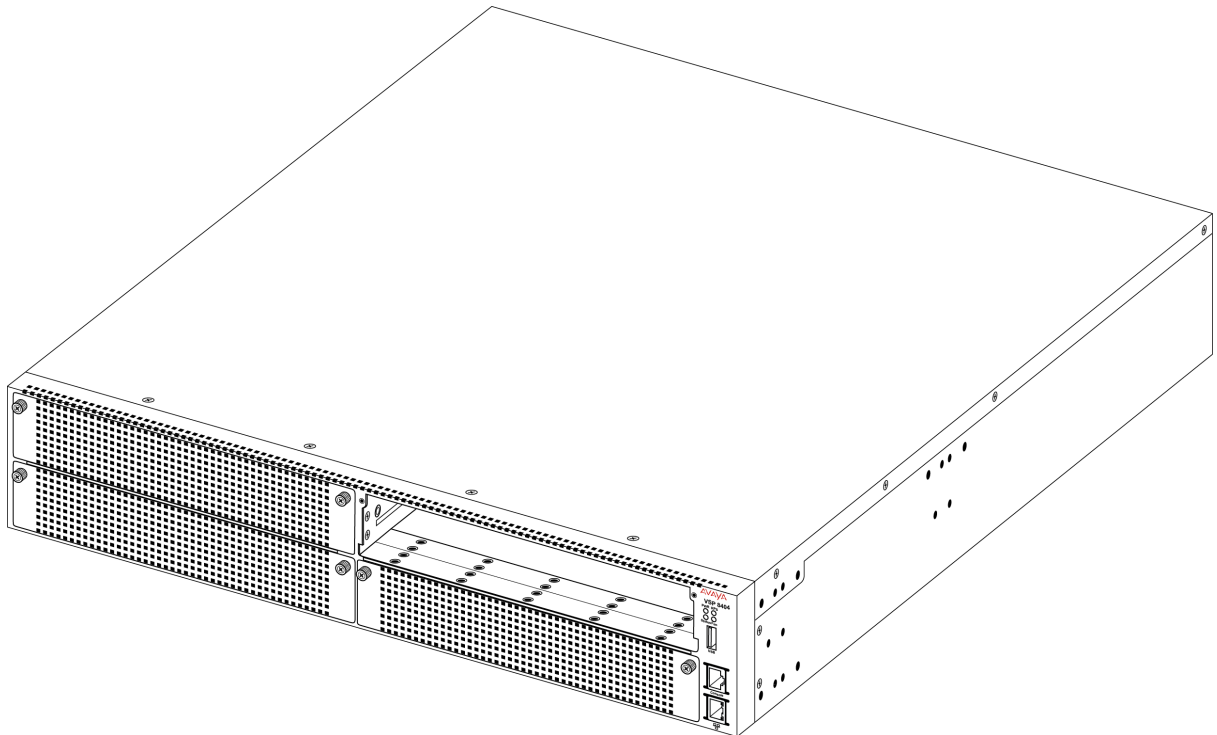

2. Slide the module into the bay.

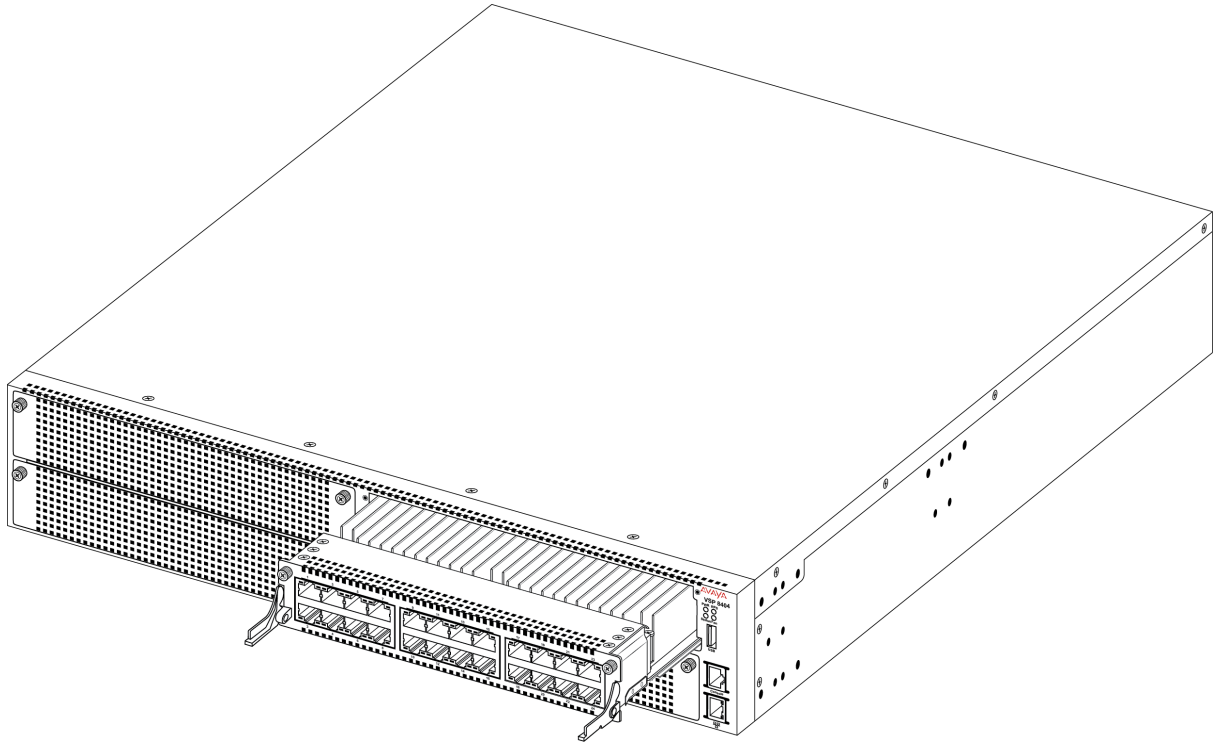

3. Apply gentle pressure anywhere on the faceplate to fully insert the module, and then screw the module in to ensure a good connection and to secure it to the chassis.

*** Note:**

The levers are designed to stay in the position shown when the module is inserted into the chassis. The levers are pulled upwards to extract the module.

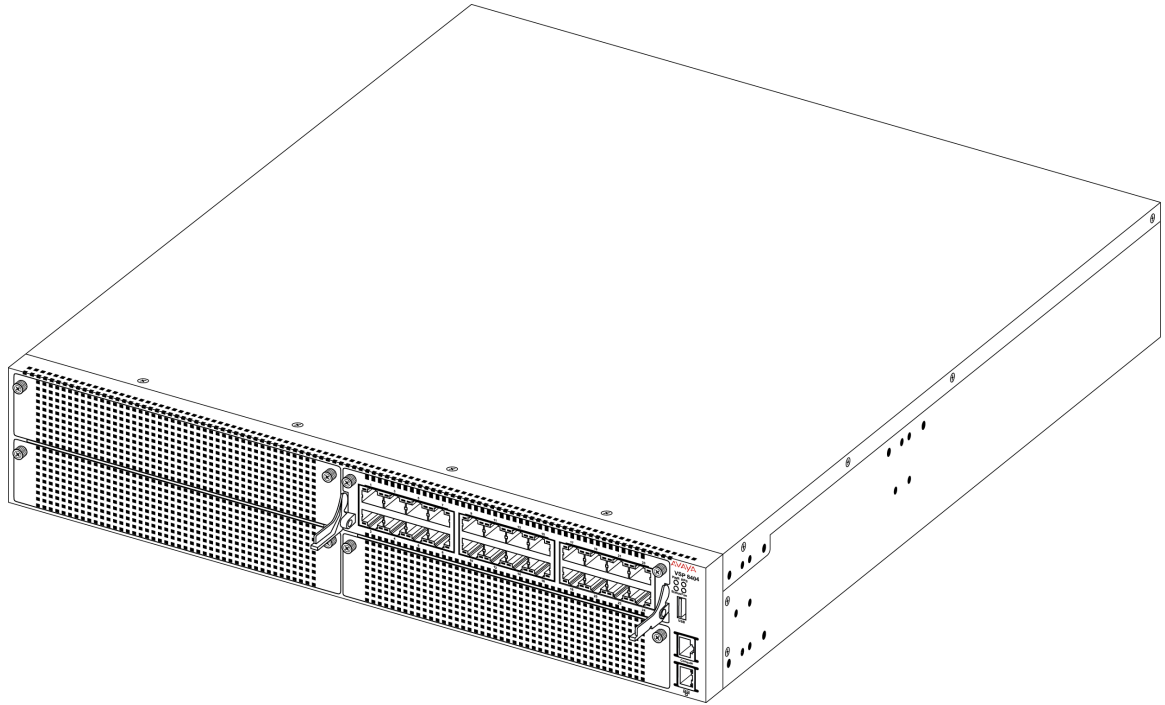

If you have to remove a module, loosen the two screws that secure the module to the chassis and rotate the extract levers up to eject the module from the chassis. Remove the module, and then either install another module or replace the module bay cover.

! Important:

You must have either a module or a module bay cover in each bay to ensure proper ventilation. Leaving a module bay unpopulated or uncovered impairs the ability of the fans to cool the chassis.

Hot swap of VSP 8400 Ethernet Switch Module

Hot swap feature is the ability to add, remove or replace system components without shutting down the system and without interrupting the operation of the system when components are inserted or removed. The VSP 8400 supports the hot swap of ESMs, power supply units and fan modules.

*** Note:**

Currently, the VSP 8404 supports only two ESM types that have the same number of ports, **8424XT** and **8424XS** both have 24 ports, however, they cannot replace one another in a hot swap situation.

The following table explains the method of hot swapping in VSP 8400.

Table 4: Methods of hot swapping in VSP 8400

Hardware	Description
Power supply	You can hot swap power supplies while the switch is operational. One power supply is required for continuous switch operation.
ESM	Any ESM can be hot swapped or replaced with the same ESM type. The rest of the configuration continues to work as original until the ESM comes online, after which the configuration for that ESM is applied.
	Any ESM except the 8424XT can be hot swapped or replaced with a different ESM type. The rest of the configuration continues to work as original until the replacement ESM comes online. When the replacement ESM is online the previous configuration for that slot is removed from the running configuration. The new ESM type can now be configured.
	An 8424XT ESM can only be hot swapped or replaced with another 8424XT ESM. The rest of the configuration continues to work as original until the ESM comes online, after which the configuration for that ESM is applied.
	If an 8424XT ESM is hot swapped or replaced with some other ESM type or if some other ESM type is replaced with an 8424XT ESM, the system must be rebooted to utilize that slot.

40G channelization

Channelization allows you to configure each 40Gbps QSFP+ ports to operate as four separate 10Gbps ports. You can use QSFP+ to four SFP+ breakout cables or QSFP+ transceivers with fiber breakout cables to connect the 10 Gigabit Ethernet ports to other servers, storage, and switches. By default, the ports are not channelized, which means that the 40Gbps QSFP+ ports operate as 40Gbps ports. You can enable or disable channelization on a port.

For breakout cable (BOC) details, see *Installing Transceivers and Optical Components on Avaya Virtual Services Platform 7200 Series and 8000 Series*, NN47227-301.

Electrostatic discharge

This section provides information and procedures to prevent electrostatic discharge during installation.

Preventing electrostatic discharge damage

Electrostatic discharge (ESD) is a discharge of stored static electricity that can damage equipment and impair electrical circuitry. Electrostatic voltages can result from friction including, pulling cabling through conduits, walking across carpeted areas, and building static charge in clothing. When you improperly handle electronic components, ESD damage occurs and can result in complete or

intermittent failures. While networking equipment is commonly designed and tested to withstand common mode ESD events, voltage can sometimes discharge to some connector pins, which can potentially damage the networking equipment.

⚠ Caution:

To protect the switch against ESD damage, take the following measures before you connect data cables to the device:

- Always use antistatic wrist straps. Make sure you adjust the strap to provide good skin contact.
- Ensure that you properly ground work surfaces and equipment racks for protection against electrostatic discharge. You must connect the common point to the building ground wire. In a properly wired building, the nearest reliable ground is typically at the electrical outlet.
- Avoid contact between equipment and clothing. The wrist or ankle strap protects only the equipment from ESD voltages on the body; ESD voltages on clothing can still cause damage.
- Avoid touching any connector pins.
- Do not remove the wrist or ankle strap until the installation is complete.

Preventing electrostatic damage in new cable installations

With new cable installations, Avaya recommends that you use an ESD discharge cable to reduce the potential for damage from static, that can build up in cables. The following figure illustrates an ESD cable.

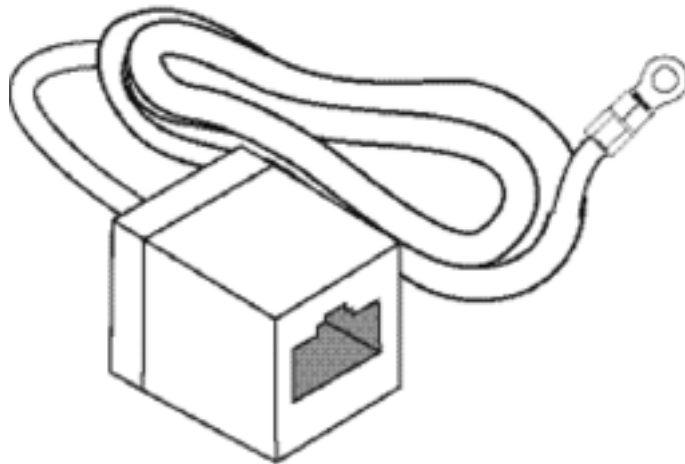

Figure 8: Job aid

To install the ESD discharge cable, perform this procedure.

1. Connect the ground lug on the ESD discharge cable to a safe and suitable earth ground.
2. Connect all RJ-45 cable connectors to the female RJ-45 connector of the ESD discharge cable for at least 5 seconds, and then connect each RJ-45 cable connector to the switch.

3. Leave cables connected to the networking equipment. After you connect cables to networking equipment, the cables do not build up charge.

Technical specifications

The following table provides the technical specifications for the individual switches in this series. Ensure that the area where you install the switch and where it operates meets these requirements.

 **Warning:**

To avoid bodily injury from hazardous electrical shock and current, never remove the top of the device. No user-serviceable components are inside.

Table 5: Physical specifications

Specifications	8200	8400
Height	3.5 in. (88.9mm) — 2U	3.5 in. (88.9mm) — 2U
Width	17.5 in. (444.5 mm) - 19" rack mountable	17.5 in. (444.5 mm) — 19" rack mount compatible
Depth	19.68 in. (500 mm)	26.5 in. (673 mm)
Weight	32.1 lb (14.56 kg) VSP 8284XSQ (EC8200x01-E6)	33.35 lb (15.13 kg) - Weight includes fan trays only (no power supplies or I/O modules) ((EC8400x01-E6))
Weight of spare AC power supply unit	1.9 lb (0.862 kg) (EC8005x01-E6)	1.9 lb (0.862 kg) (EC8005x01-E6)
Weight of spare DC power supply unit	1.76 lb (0.8 kg) (EC8005001-E6)	1.76 lb (0.8 kg) (EC8005001-E6)

Table 6: Electrical specifications

Specifications	8200	8400
Power consumption	565.34 W with no transceivers, 765.34 W with transceivers	200 W with no I/O modules, 800 W (max) with I/O modules
Thermal rating	1929.02 BTU/hr with no transceivers, 2611.448 BTU/hr with transceivers	682.4 BTU/hr with no I/O modules, 2729.7 BTU/hr with I/O modules
MTBF rating	137,000 hours (15.6 years)	Chassis = 241,723 hours 8424XS = 691,864 hours 8424XT = 582,142 hours 8408QQ = 622,514 hours 8418XSQ = 742,318 hours

Table 7: Environmental specifications

Operating Temperature	0° C to 50° C (32° F to 122° F)
Storage Temperature	–40° C to 85° C (–40° F to 185° F)
Operating Humidity	0 to 95 percent noncondensing
Storage Humidity	0 to 95 percent noncondensing
Maximum Operating Altitude	3,048m (10 000 feet) above sea level
Storage Altitude	0 to 12,192m (0 to 40,000 feet) above sea level
Acoustic Noise	Less than or equal to 35 db at 21° C and less than or equal to 43 db at 50° C. The temperature is allowed to have $\pm 3.5^{\circ}$ C deviation around the threshold of 35C, (measurement methods based on ISO 7779).
Miscellaneous Operating Considerations	<ul style="list-style-type: none"> • No heat sources such as hot air vents or direct sunlight near the switch. • No sources of severe electromagnetic interference near the switch. • No excessive dust in the environment. • An adequate power source is within 6 feet (1.83 meters) of the switch. One 15-amp circuit is required for each power supply. • At least 2 inches (5.08 centimeters) of clearance on the front and back of the switch for ventilation. • Cables should be dressed to prevent blocking air flow.

Package contents

The following describes the components that are provided with each switch. If any components are missing, contact Avaya.

1. Avaya Virtual Services Platform 8000 Series switch
2. Rack-mounting hardware that includes:
 - Rack-mount brackets
 - Screws to attach brackets to the switch
 - Screws to secure the switch to the equipment rack
3. The Avaya Virtual Services Platform 8000 Series supports two field-replaceable power supplies. One power supply ships with the unit.
4. Power cord

8200

- The VSP 8284XSQ-AC “A” model (EC8200A01–E6) does not include a power cord for the AC power supply. All other models include a country-specific power cord.

- The VSP 8284XSQ-DC model (EC8200001–E6) ships with a DC power supply wiring assembly for the DC power supply.
- The VSP 8284XSQ AC PS No PC GSA model (EC8200A01–E6GS) does not include a power cord. This model is TAA compliant.
- The VSP 8284XSQ AC PS NA PC GSA model (EC8200E01–E6GS) includes a North American power cord. This model is also TAA compliant.

8400

- The VSP 8404 “A” model (EC8400A01-E6) does not include a power cord for the AC power supply. All other models include a country-specific power cord.
 - The VSP 8404 model (EC8400001-E6) ships with a DC power supply wiring assembly for the DC power supply.
 - The VSP 8404 AC PS No PC GSA model (EC8400A01–E6GS) does not include a power cord. This model is TAA compliant.
 - The VSP 8404 AC PS NA PC GSA model (EC8400E01–E6GS) includes a North American power cord. This model is also TAA compliant.
5. Four field-replaceable fan trays
 6. Documentation

*** Note:**

A 300mm-900mm slide rack mounting kit is available as an option.

Installing the VSP 8000 Series in an equipment rack

*** Note:**

The instructions in this section apply to all switches in the Avaya Virtual Services Platform 8000 Series. The illustrations show the VSP 8200 as an example, but the instructions apply to any switch in the series.

There are different ways to install an Avaya Virtual Services Platform 8000 Series switch in an equipment rack. Refer to one of the following sections:

- Slide Rack Mount Kit-This is a separately ordered option that you can use to install your switch in equipment racks that range from 300 mm to 900 mm deep. For installation instructions, see [Using the optional slide rack mount kit](#) on page 35.
- Brackets-The switch comes with brackets that you can install in one of two positions on the chassis:
 - Use the mid-chassis position for a two-post rack.
 - Use the front panel position of the chassis for a four-post rack.

*** Note:**

It is highly recommended to mount the chassis on a tray designed for the specific rack and use the Avaya supplied rack mount brackets to hold the chassis in place. The chassis is heavy and could cause damage to a rack if only the brackets are used, especially in a vibration prone area.

For installation instructions, see [Using the supplied bracket](#) on page 51.

Before you begin

- Ensure that there is enough rack space to accommodate a 2 U switch (8.8 cm).
- The rack is bolted to the floor and braced if necessary.
- The rack is grounded to the same grounding electrode used by the power service in the area. The ground path must be permanent and must not exceed 1 Ohm of resistance from the rack to the grounding electrode.

About this task** Caution:**

When you mount the device in a rack, do not stack units directly on top of one another. You must secure each unit to the rack with the appropriate mounting brackets. Mounting brackets cannot support multiple units. For a translation of this statement, see [Translations of safety messages](#) on page 71.

Using the optional slide rack mount kit

The Universal Slide Rack Mount Kit is adjustable so that you can install your switch in equipment racks of different sizes. Use the following procedures to install your switch in equipment racks with a depth from 300mm to 900mm.

This kit is a separately ordered item (Part # EC8011002).

For instructions see:

- [Installing slides in a 300mm-600mm equipment rack](#) on page 35
- [Installing slides in a 600mm-900mm equipment rack](#) on page 44
- [Important notice about rack safety](#) on page 48
- [Removing the switch from an equipment rack](#) on page 49

 Warning:

If you pull the switch all the way out on the slide rails, there is a danger of the rack tipping over. For more information and guidelines, see [Important notice about rack safety](#) on page 48.

Installing slides in a 300mm-600mm equipment rack

Use the following procedure to install your switch in an equipment rack with a depth between 300mm and 600mm.

Procedure

1. Disconnect the power cord from the switch.
2. Use the following steps to detach the chassis rail from the slide's rack rail:
 - a. Pull the inner chassis rail and slide it out as far as you can.

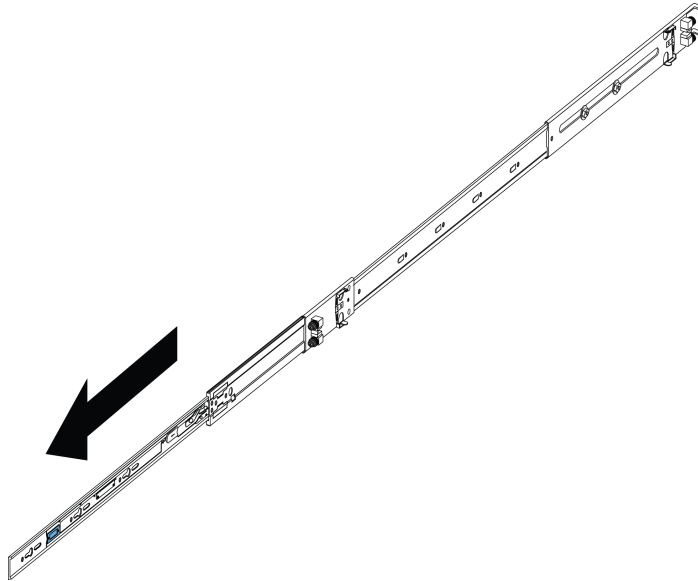

- b. Slide the white release lock in the direction of the arrow stamped on the lock.

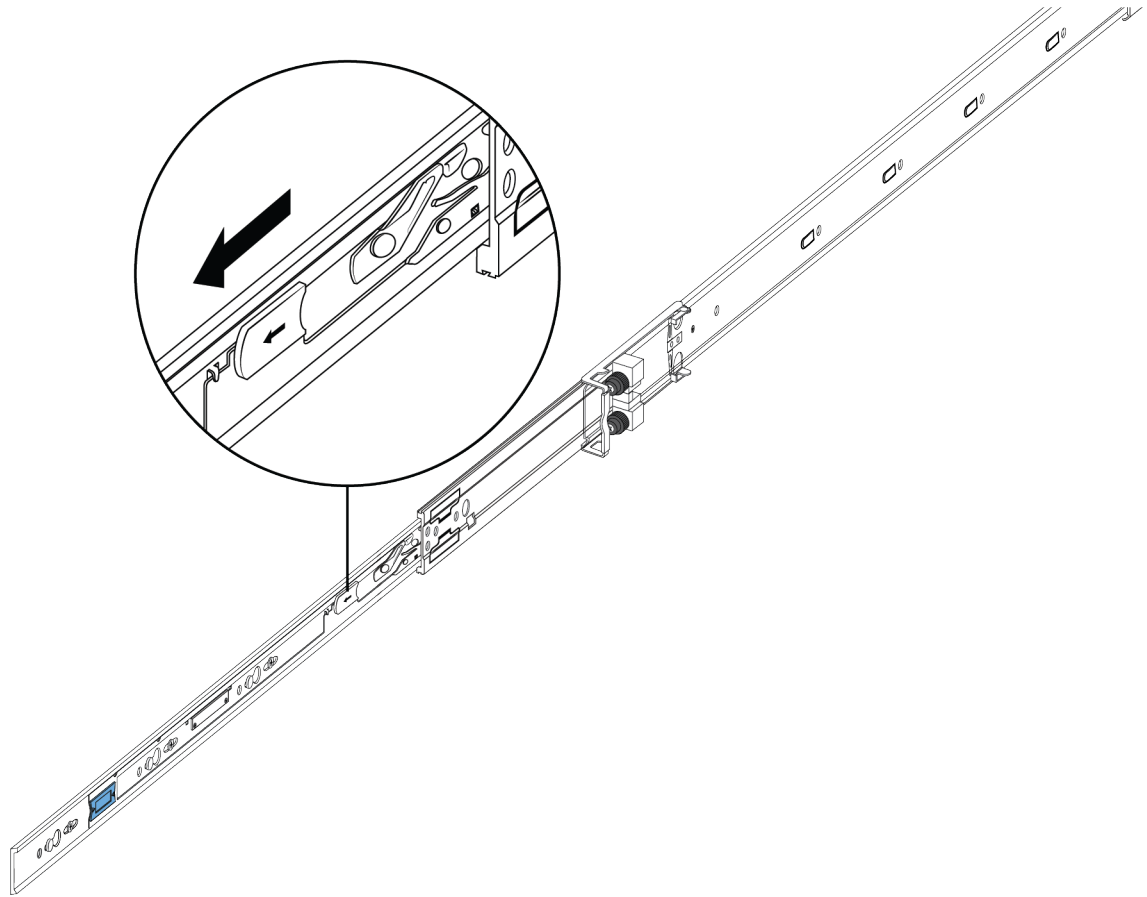

3. Lift the locking mechanism on the rack rail to slide the outer section back into the main section.

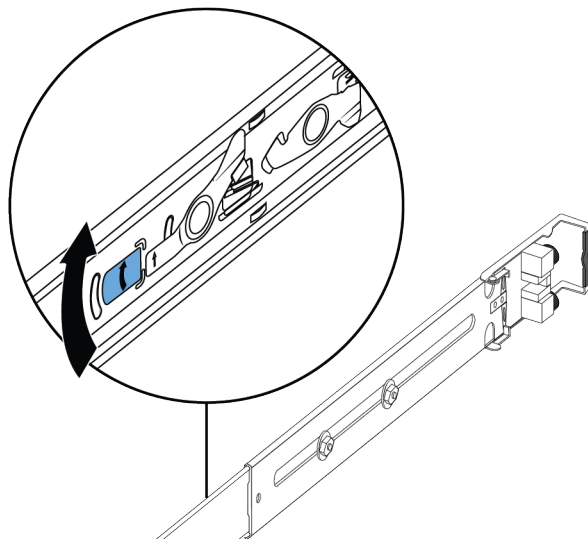

4. Use the following steps to attach the chassis rail to the chassis:
 - a. Orient the chassis rail with the blue release lock towards the front and position the rail over the standoffs on the chassis.

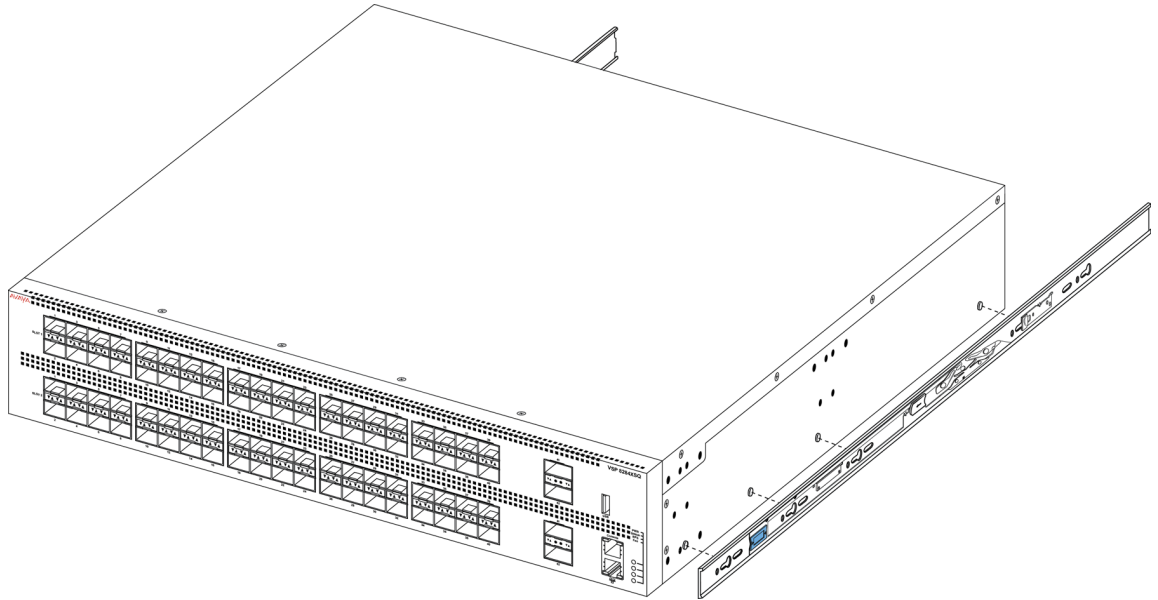

- b. Slide the chassis rail to the rear until the rail locks into the standoffs.

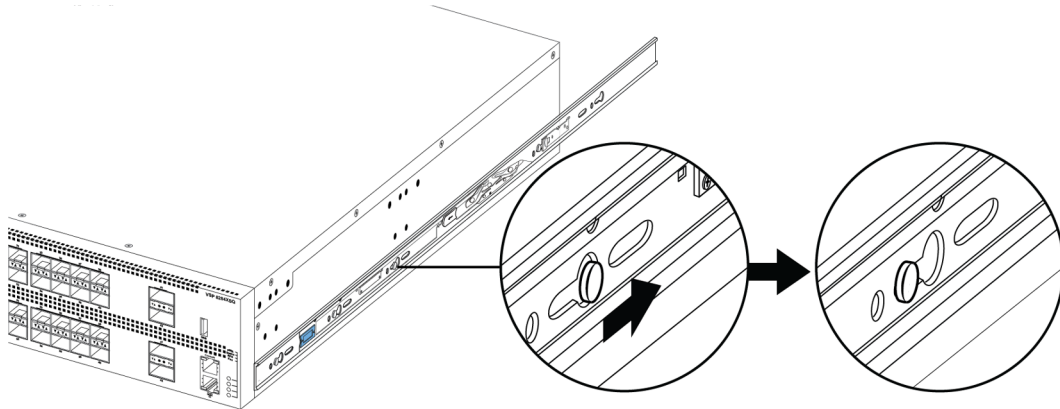

- c. Make sure the safety tab locks into place.

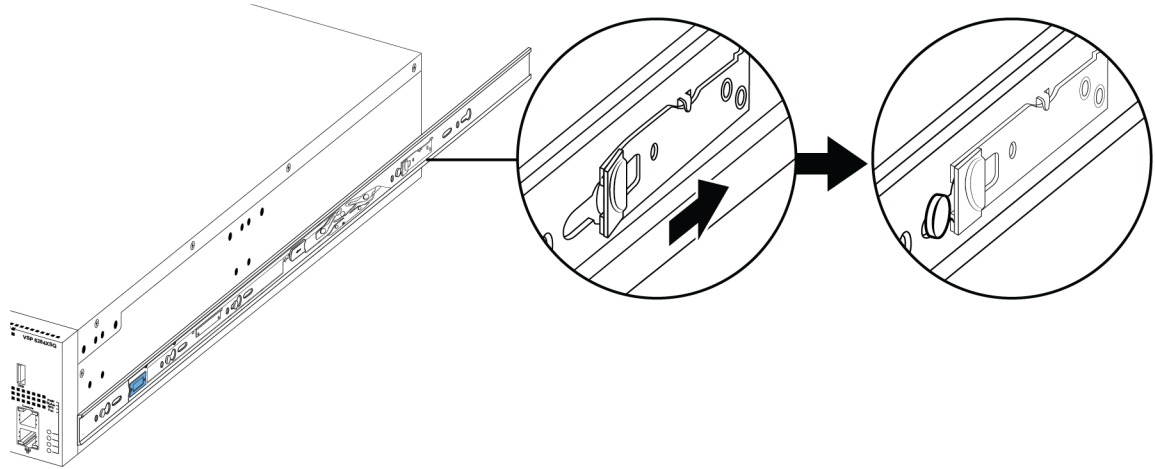

5. Use the following steps to secure the rack rails to the frame:
 - a. Orient the rack rail so that the end with the black latch is facing front.
 - b. Adjust the length of the rack rail so it fits the rack depth by loosening the two screws on the rack rail, adjusting the length, and then tightening the screws.

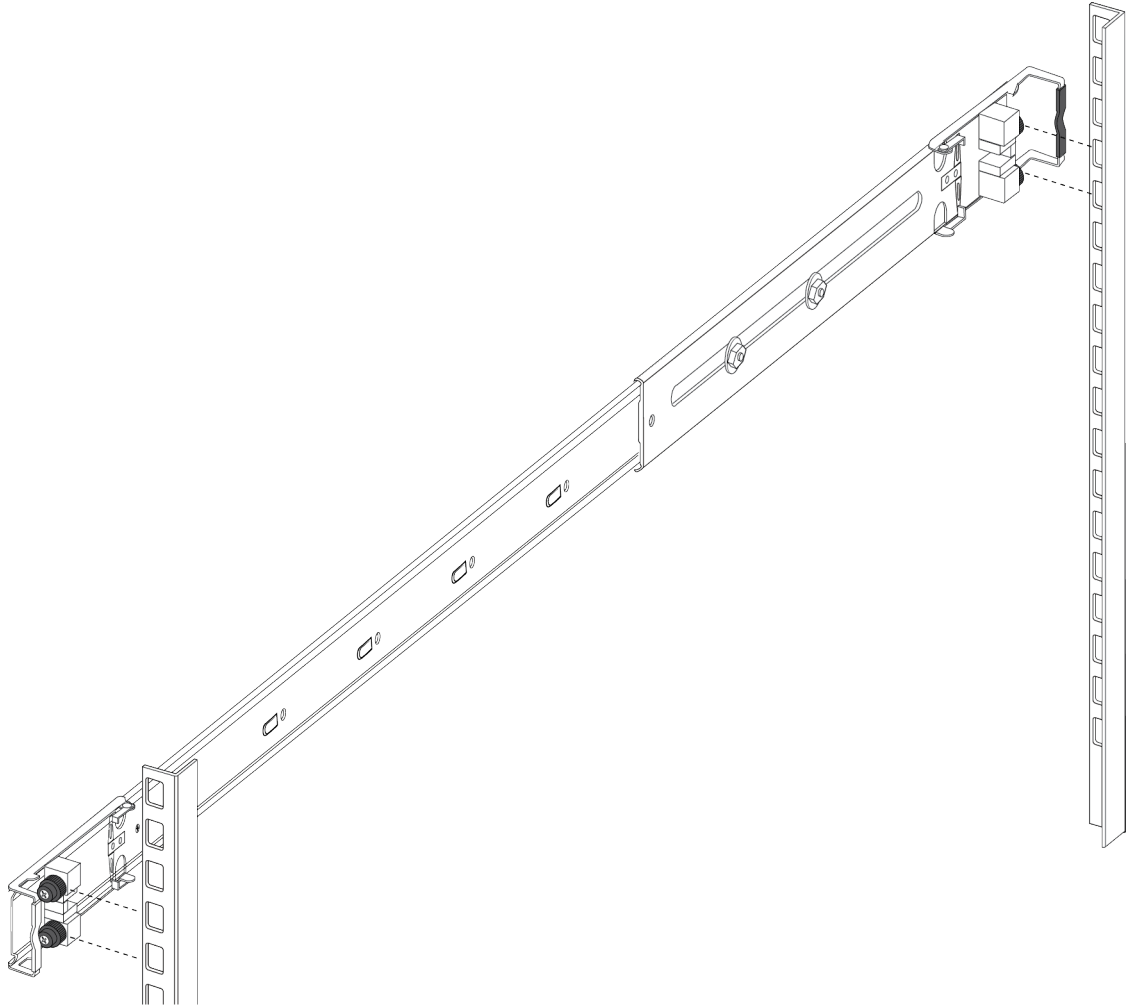

- c. Push the end of the front bracket assembly so it opens up.

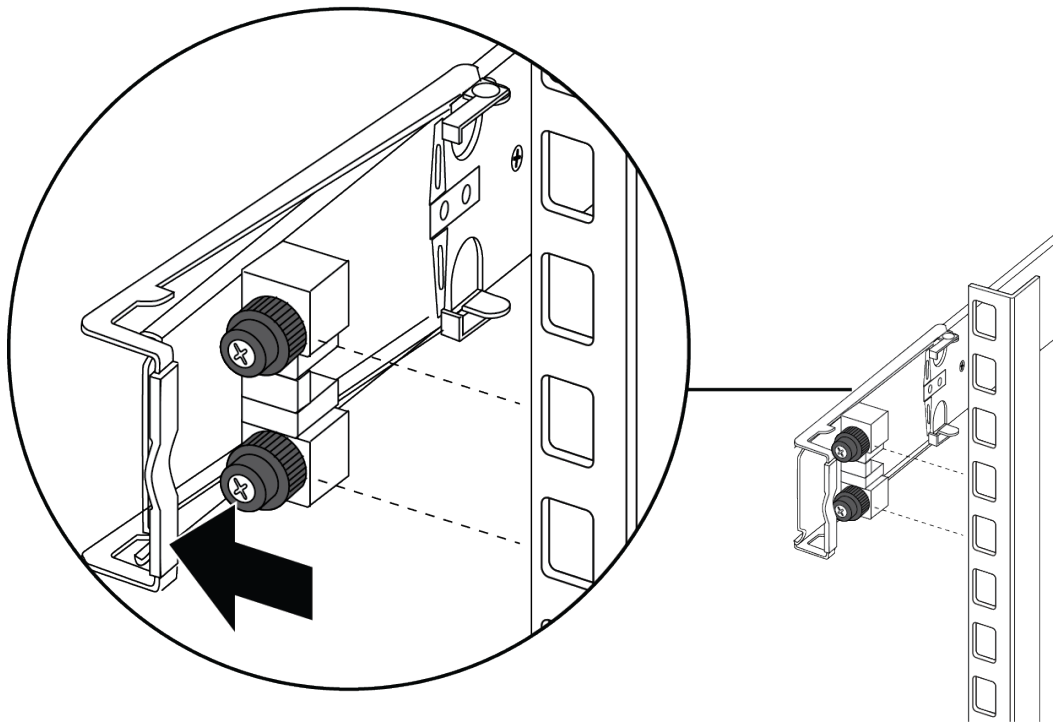

d. Insert the bracket pins into the desired holes in the frame.

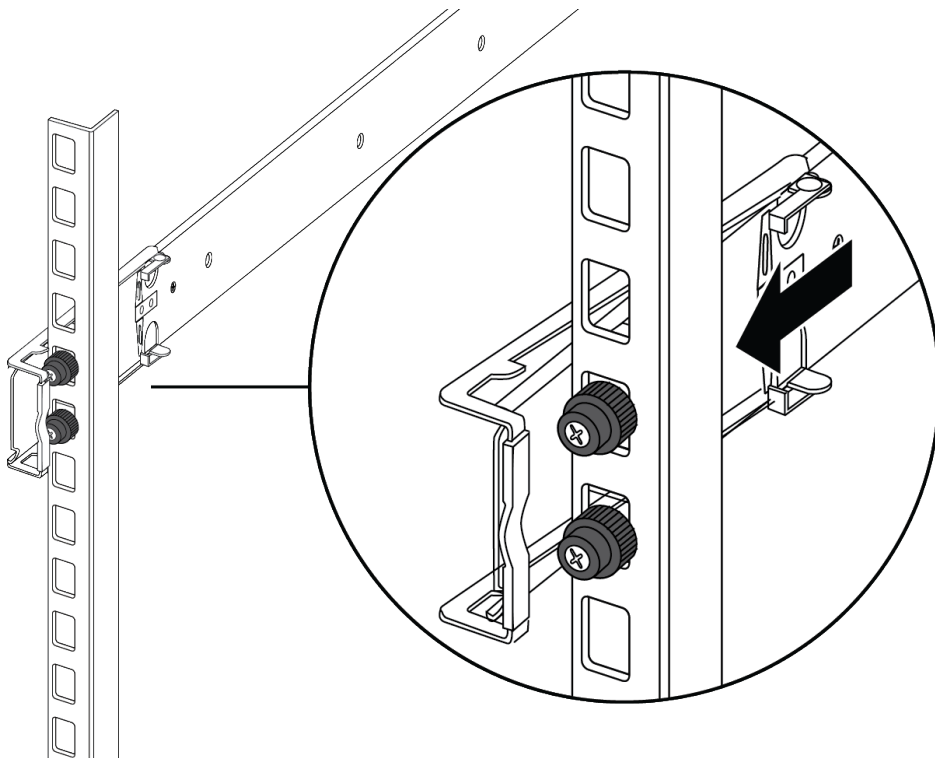

e. Close the bracket assembly so that it wraps around the frame and locks into place.

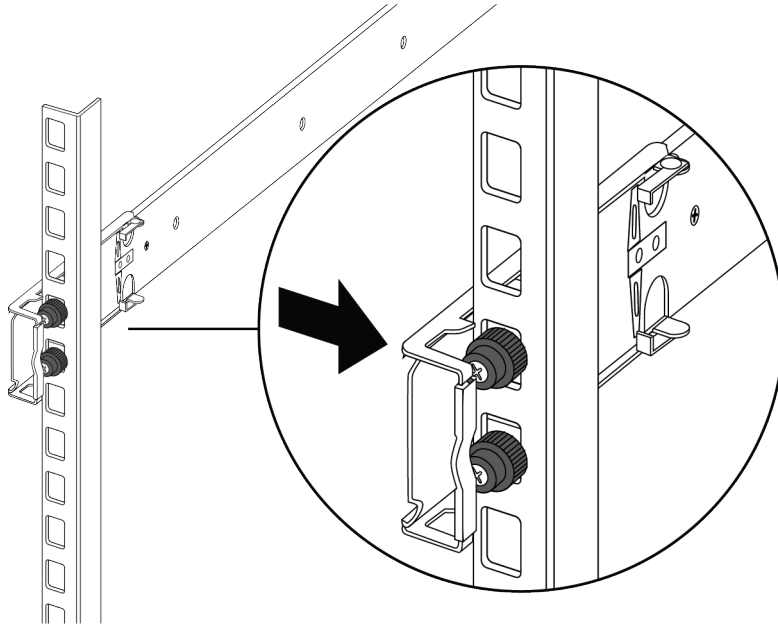

- f. Repeat the above steps on the rear bracket.
 - g. Repeat these steps for the rack rail on the other side of the frame.
6. Use the following steps to install the switch in the equipment rack to complete the installation:
- a. Insert the chassis rails on the switch into the rack rails on the frame.

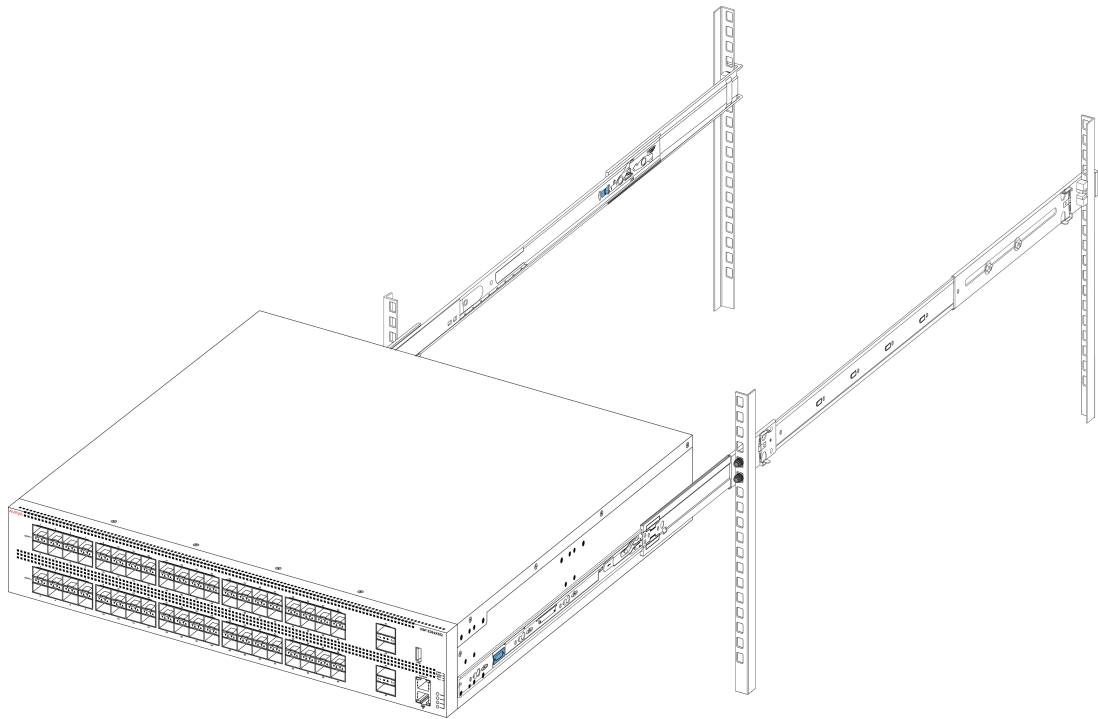

- b. Pull the blue locks on the chassis rails towards the front and slide the switch into the frame.

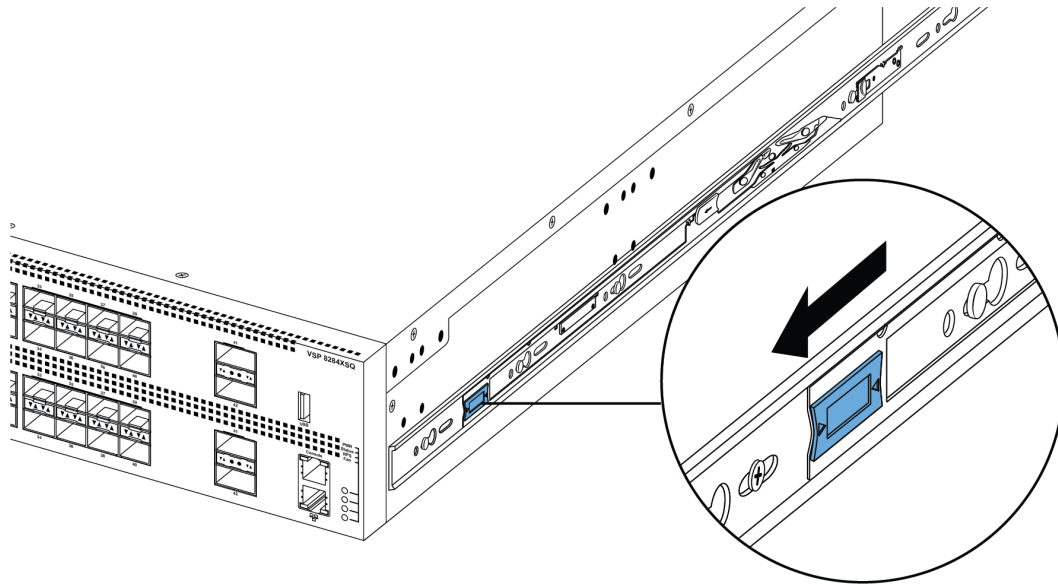

*** Note:**

After you install the switch in a rack, slide it out until the lock (shown above) engages. To slide the switch back into the rack, push the blue locks on the chassis rails towards the back and slide the switch into the frame.

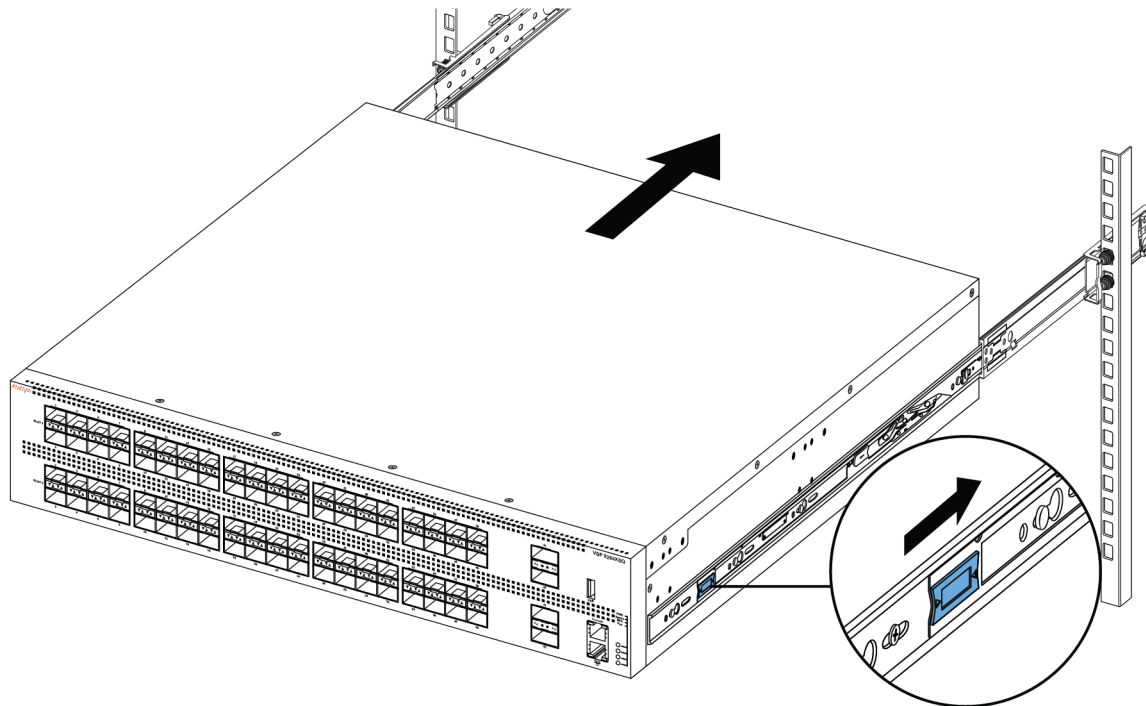

7. Connect power and network connections to the switch.

Installing slides in a 600mm-900mm equipment rack

Use the following procedure to install your switch in an equipment rack with a depth between 600mm and 900mm.

Procedure

1. Disconnect the power cord from the switch.
2. Detach the chassis rail from the slide's rack rail. (See Step 2 of [Installing slides in a 300mm-600mm equipment rack](#) on page 35.)
3. Lift the locking mechanism on the rack rail to slide the outer section back into the main section. (See Step 3 of the 300mm-600mm instructions.)
4. Attach the chassis rail to the chassis. (See Step 4 of the 300mm-600mm instructions.)
5. Remove the two screws and nuts securing the short rear bracket to the rack rail. This bracket is for 300mm-600mm equipment racks only and is not used in this installation. Save the bracket for possible future use.

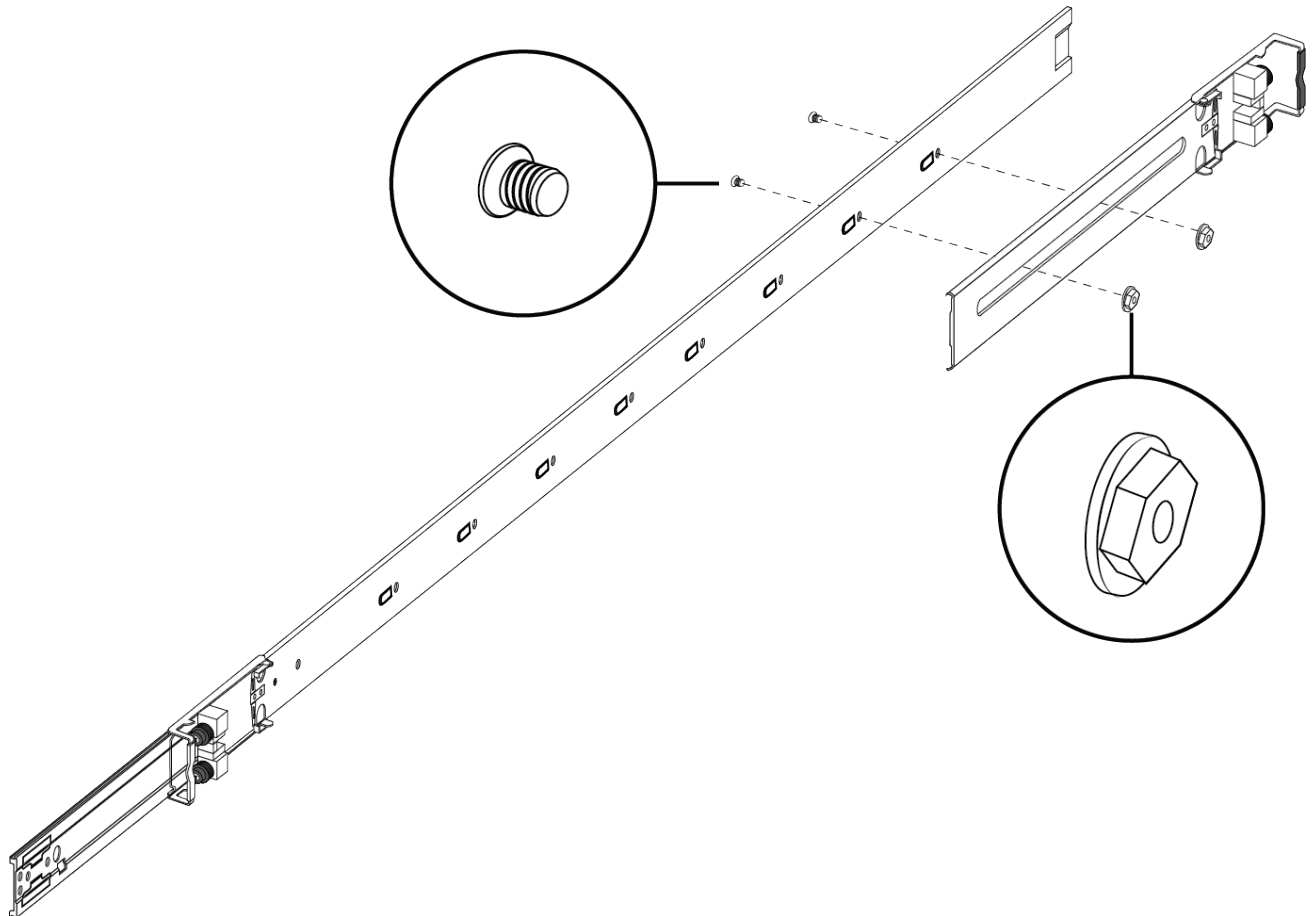

6. Use the bag with 10 countersink screws and following steps to attach the supporting plates to the rack rails:
 - a. Push the release lock up and slide the middle rail out as far as possible.

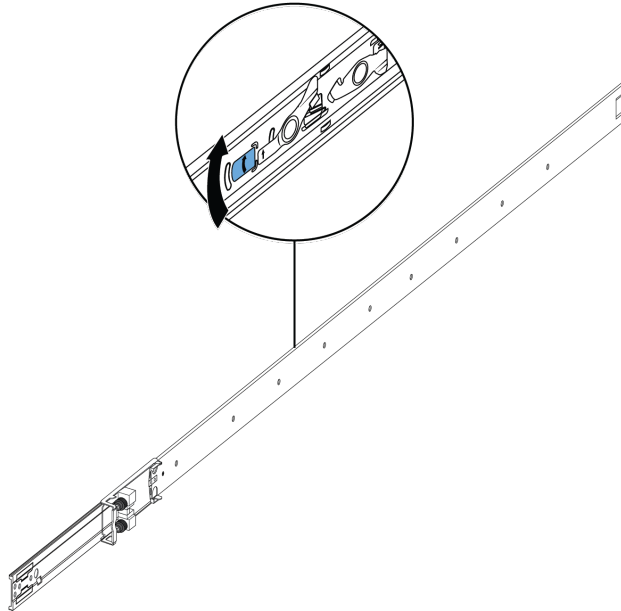

- b. Orient the supporting plate over the holes in the rack rail.
 - c. Install the first two screws on one end.
 - d. Lift the locking mechanism and slowly slide the rail back into the main assembly. This exposes a “window” over the screw holes so you can install the remaining three screws one at a time.

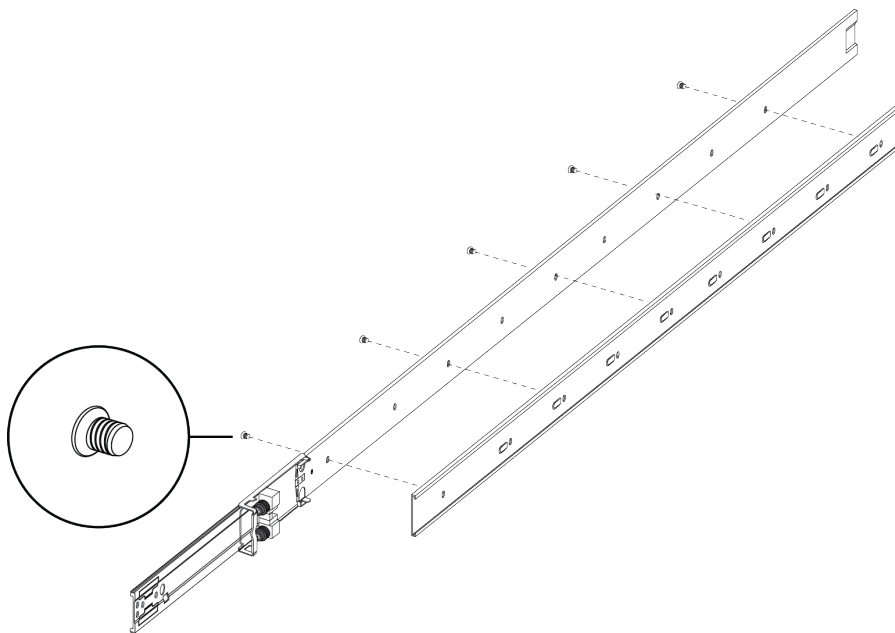

7. Insert the long rack rail bracket into the supporting plate.

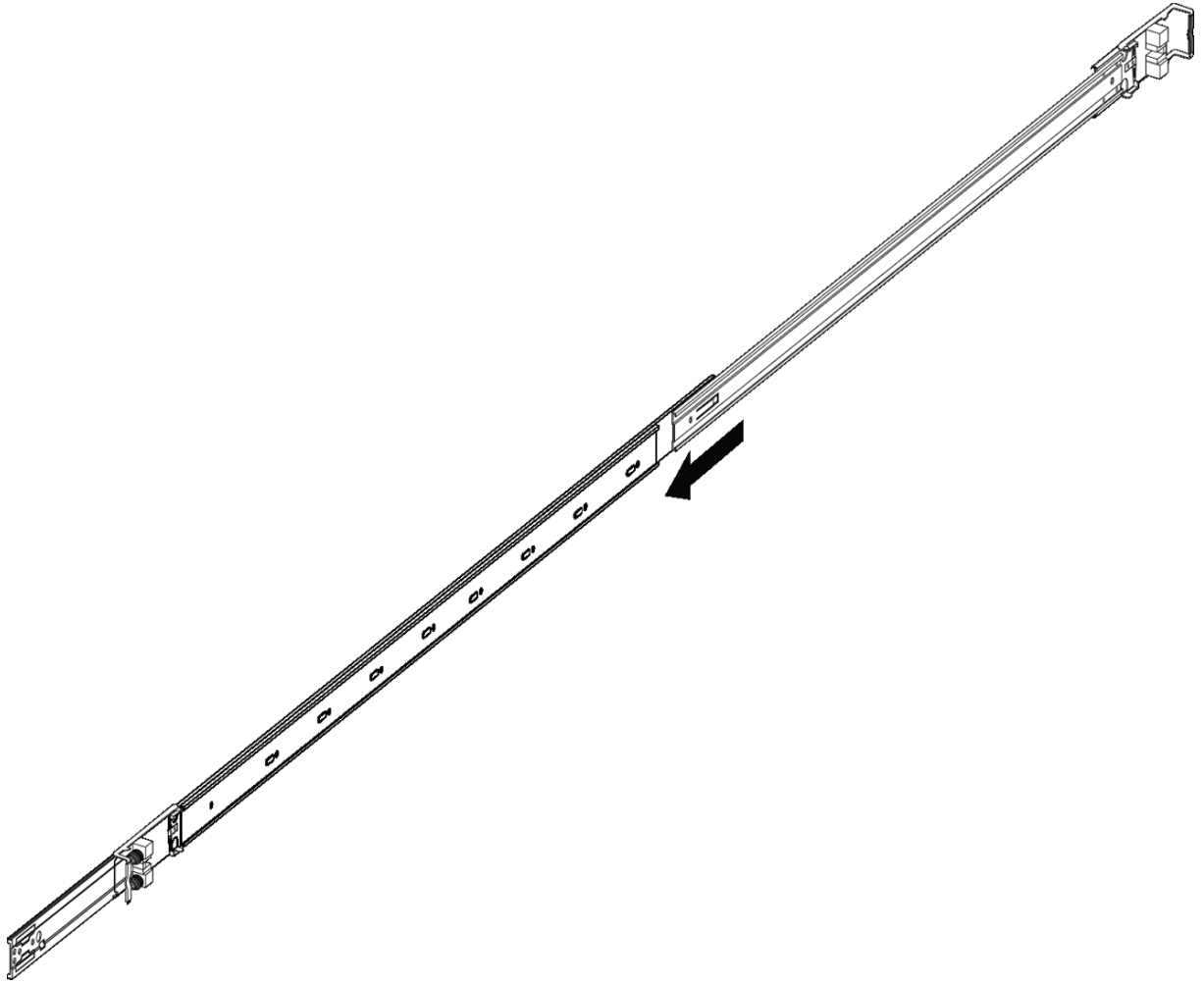

8. Use the following steps to secure the rack rails to the frame:
 - a. Orient the rack rail so that the end with the black latch is facing front.
 - b. Push the end of the front bracket assembly so it opens up.
 - c. Insert the bracket pins into the desired holes in the frame.
 - d. Close the bracket assembly so that it wraps around the frame and locks into place.

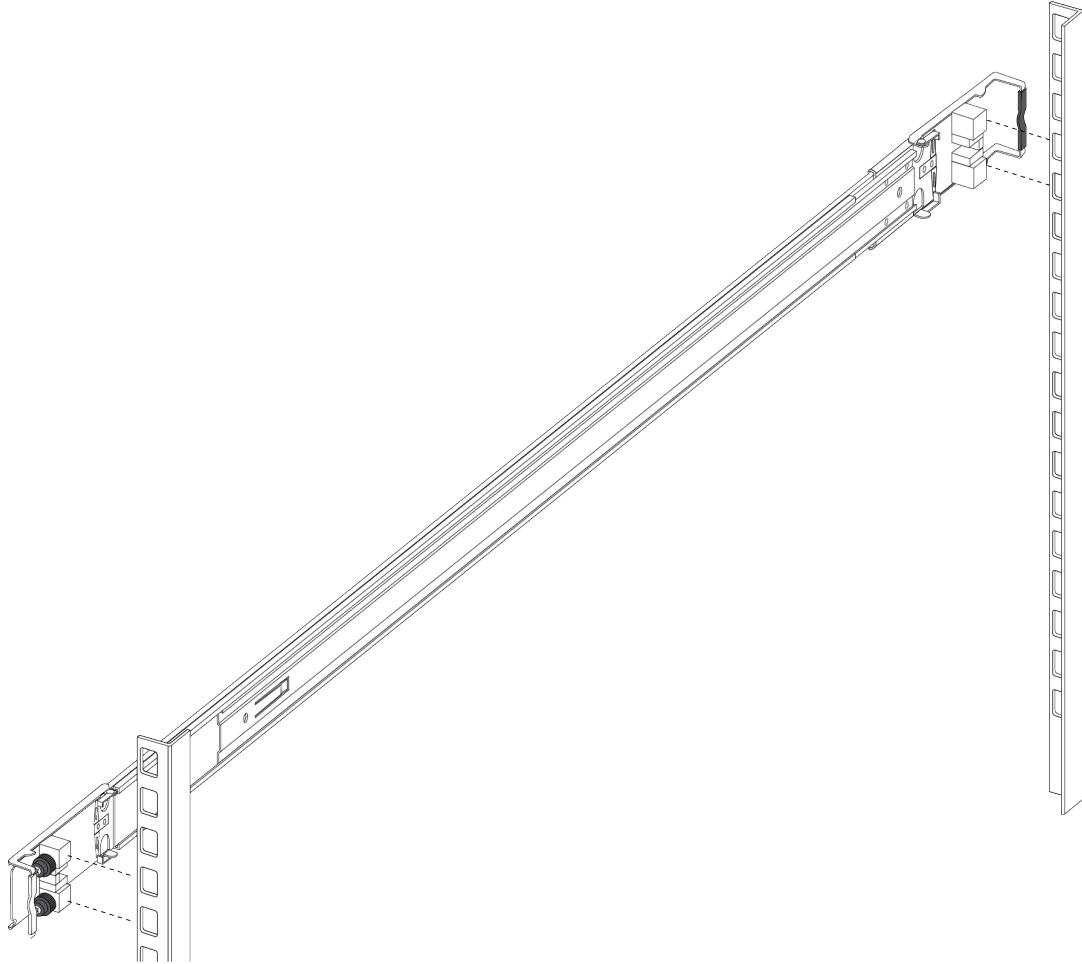

- e. Repeat the above steps on the rear bracket.
 - f. Repeat these steps for the rack rail on the other side of the frame.
9. Install the switch in the equipment rack to complete the installation. (See Step 6 of the 300mm-600mm instructions.)
- a. Insert the chassis rails on the switch into the rack rails on the frame.
 - b. Pull the blue locks on the chassis rails towards the front and slide the switch into the frame.

*** Note:**

After you install the switch in a rack, slide it out until the lock (shown above) engages.

To slide the switch back into the rack, push the blue locks on the chassis rails towards the back and slide the switch into the frame.

10. Connect power and network connections to the switch.

Important notice about rack safety

One prerequisite to installing the switch in an equipment rack is to bolt the equipment rack to the floor. This section emphasizes the safety issue if you do not bolt the rack to the floor.

⚠ Warning:

If you pull the chassis all the way out on the slide rails, there is a danger of the rack tipping over.

This can happen if your equipment rack is not bolted to the floor and there are no other devices installed as shown in the following figure. To avoid this danger, refer to the guidelines in the graph below the figure.

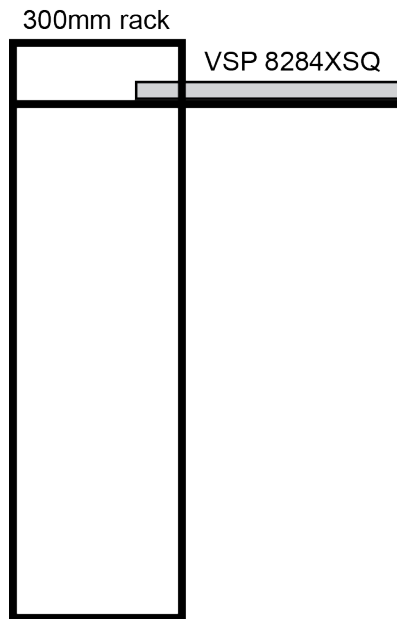

If your rack meets the following guidelines and you pull the chassis all the way out, the rack is in danger of tipping over:

- 900mm equipment rack that weighs less than 14kg
- 600mm equipment rack that weighs less than 21kg
- 300mm equipment rack that weighs less than 42kg

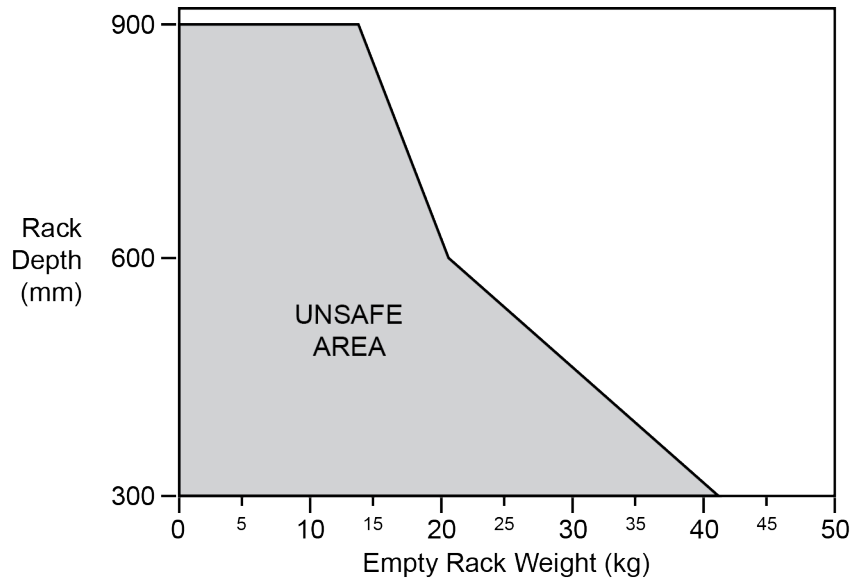

Removing the switch from an equipment rack

Follow these steps if you have to remove the switch from an equipment rack.

! Important:

This procedure requires two people.

Procedure

1. Disconnect the power cord from the switch.
2. Slide the switch out until the lock engages.

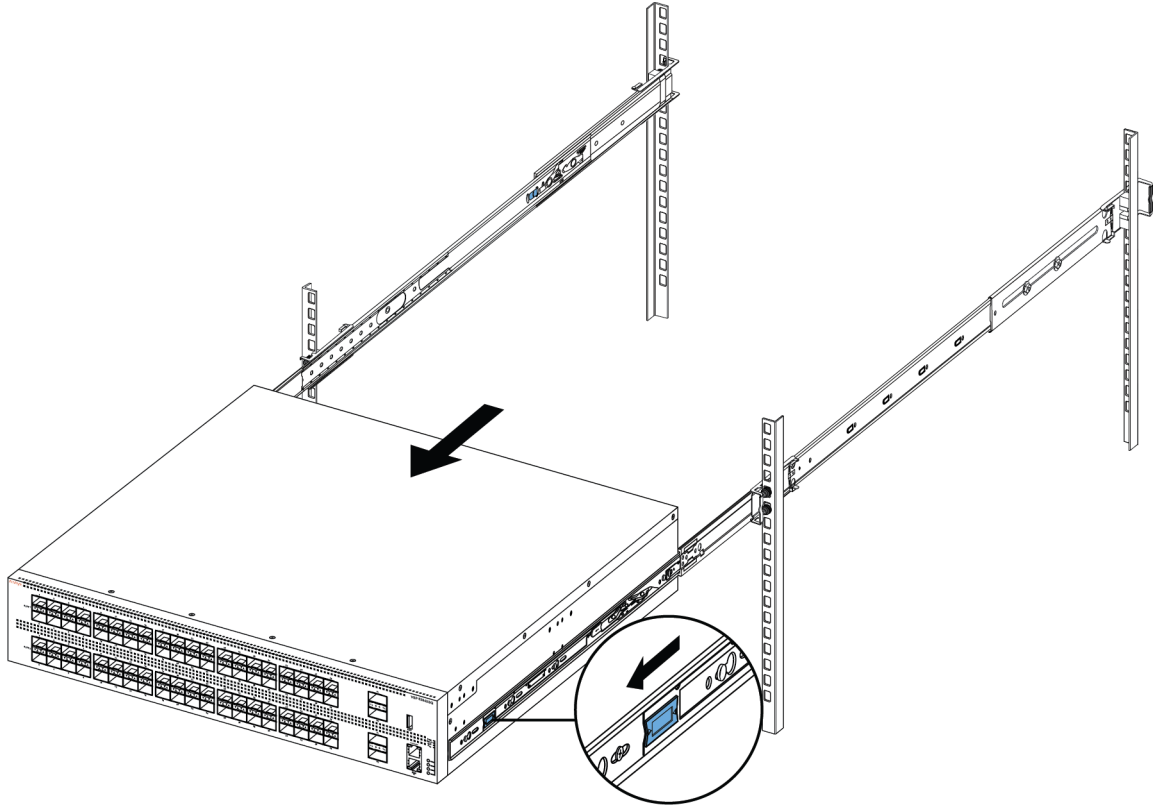

3. While the person standing in back of the chassis slides both of the white release locks (one on each side of the chassis) towards the front, the person standing in front of the chassis pulls the chassis out of the rack.

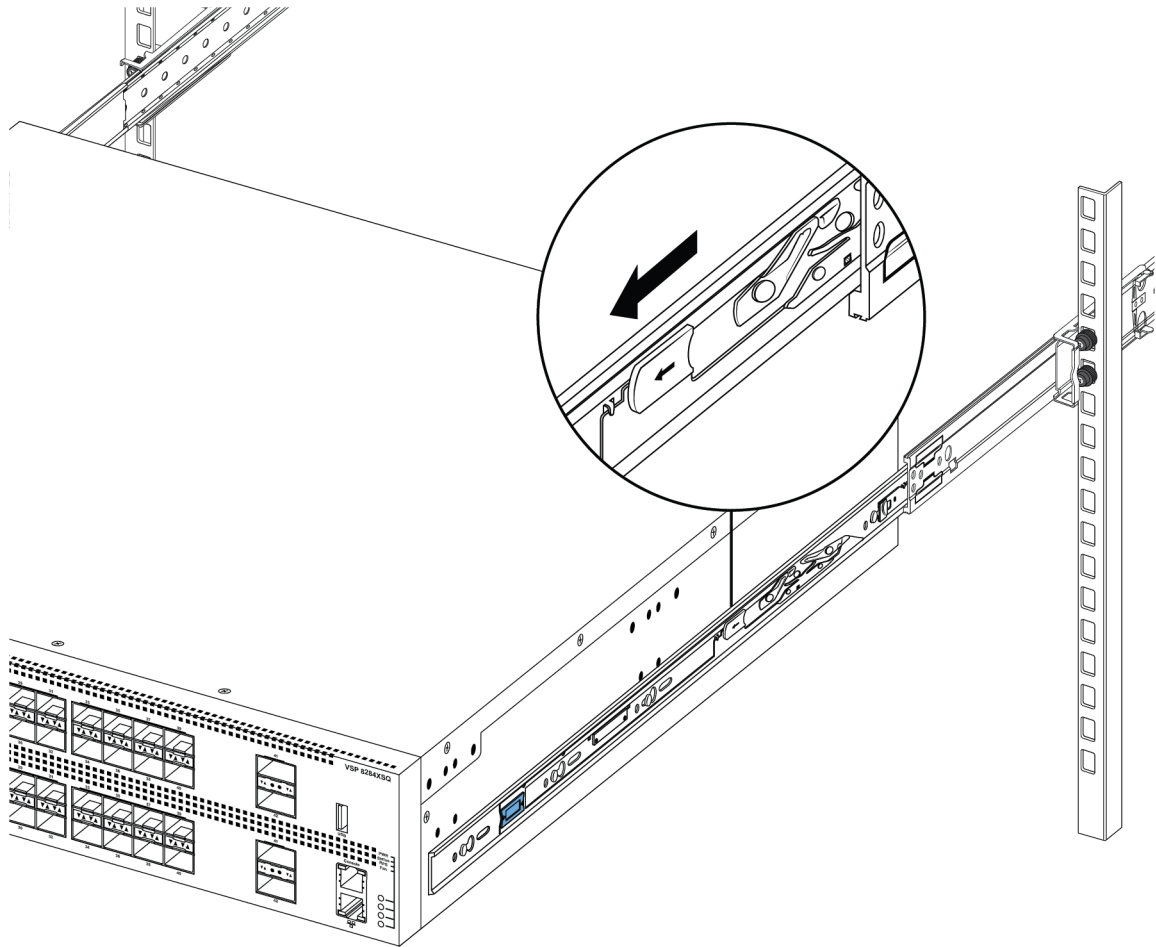

Using the supplied brackets

This procedure describes how to install the switch using the supplied brackets on a two-post or four-post equipment rack. The brackets secure the chassis and prevent it from sliding around during vibration or when inserting or extracting transceivers.

- If you have a two-post rack, install the brackets in the mid-chassis position (VSP 8200 only).
- If you have a four-post rack, install the brackets in the front chassis position. In the front position, the switch should rest on a customer-supplied tray or shelf.

Caution:

Do not mount the chassis with brackets in the front position without using a tray under the chassis. The chassis weight will cause damage to a rack when mounted by the front panel, especially in an environment with vibration or in an earthquake prone area.

Procedure

1. Disconnect the power cord from the switch.

2. Attach a bracket to each side of the switch using a #2 Phillips screwdriver as illustrated below.

⚠ Caution:

The following figure shows the bracket position for a 4-post rack installation. If you are installing the chassis in a 2-post rack, attach the bracket in the location recessed 150 mm from the front of the chassis.

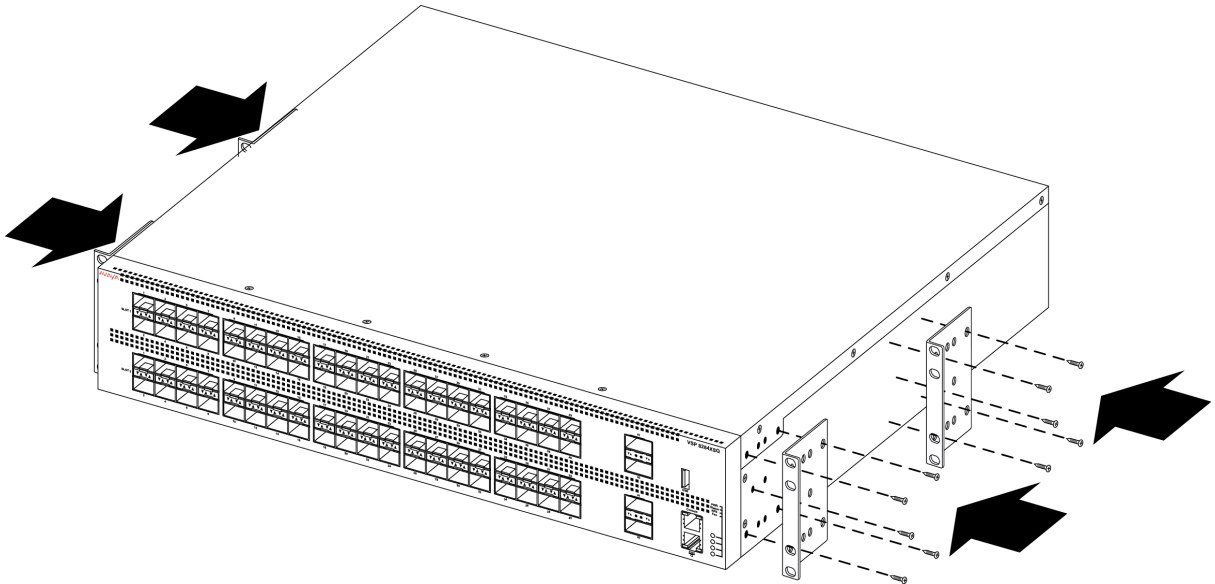

3. Slide the switch onto a shelf or tray in the rack.

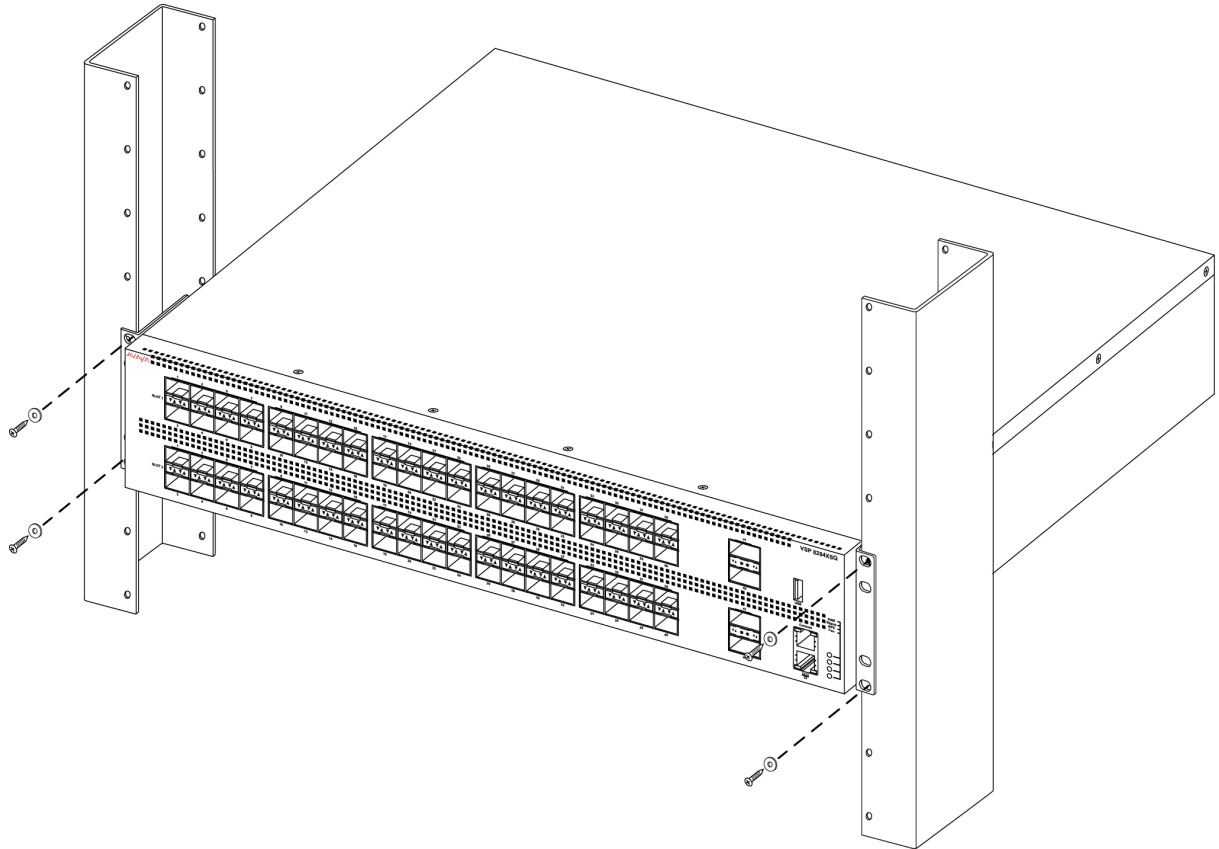

4. Insert and tighten the rack-mount screws.
5. Verify that the switch is securely fastened to the rack.
6. Connect power and network connections to the switch.

Cable requirements for the VSP 8000 Series

The following table describes the cables required for an Avaya Virtual Services Platform 8000 Series.

Table 8: Switch cable requirements

Required Cable	Description
10/100/1000BASE-TX Ports	The interconnect cabling must conform to the Cat5e, Cat6, or Cat6e specification of the Commercial Building Telecommunications Cabling Standard, ANSI/TIA/EIA 568-B fitted with an RJ-45 Module jack.
Console Port (10101)	Varies depending on the user device. The Avaya Virtual Services Platform 8000 Series has an RJ-45 female connector so a serial

Table continues...

Required Cable	Description
	cable with an RJ-45 connector on one end and an RJ-45 on the other is appropriate. The maximum length for the console port cable is 25 feet (8.3 meters).
SFP+ and QSFP+ Transceiver Ports	Varies with the installed transceiver. See the documentation shipped with the transceiver for specifications.

Installation and removal of transceivers

The following sections describe how to install and remove transceivers in the Avaya Virtual Services Platform 8000 Series switch. In this context, the term *transceiver* refers to Small Form Factor Pluggable (SFP), SFP+, and Quad 4-channel SFP (QSFP+).

For more information about transceiver use and designation, see *Installing Transceivers and Optical Components on Avaya Virtual Services Platform 7200 Series and 8000 Series*, NN47227-301.

Installing transceivers

Install transceivers by performing this procedure.

1. Remove the transceiver from the protective packaging.
2. Verify that the transceiver is the correct model for the network configuration.
3. Grasp the transceiver between your thumb and forefinger.
4. Insert the transceiver into the proper slot on the switch. Apply a light pressure to the transceiver until it clicks and locks into position.
5. Remove the dust cover from the transceiver optical bores.

Removing transceivers

Remove transceivers by performing this procedure.

1. Disconnect the network fiber cable from the transceiver.
2. Use the locking mechanism on the transceiver to release it. The locking mechanism varies from model to model.
3. Slide the transceiver from the port.
4. If the transceiver does not slide easily from the port, use a gentle side-to-side rocking motion while firmly pulling the transceiver from the port.
5. Attach a dust cover over the fiber-optic bores and store the transceiver in a safe place until you need it.

! Important:

Discard transceivers in accordance with the proper laws and regulations.

Console port pin assignments

The following section describes the console port pin assignments for the RJ-45 connectors in the Avaya Virtual Services Platform 8000 Series. The Console port and Management port both use RJ-45 connectors.

Table 9: Console port pin assignments

Connector	Pin Number	Signal
	1	Ready to send (RTS) — optional
	2	Data terminal ready (DTR) — optional, can swap or link with pin 8
	3	Transmit data (TXD) — mandatory
	4	Carrier detect (DCD) — optional
	5	Ground (GND) — mandatory
	6	Receive data (RXD) — mandatory
	7	Data set ready (DSR) — optional
	8	Clear to send (CTS) — optional, can swap or link with pin 1

*** Note:**

The Table 15 — Console port pin assignments shows only the console signalling.

AC power supply

Installing an AC power supply

! Important:

Avaya does not support installing a combination of AC-input and DC-input power supplies in the same chassis.

The Avaya Virtual Services Platform 8000 Series supports two field-replaceable 800W power supplies. One comes with the switch and you can install a second power supply to provide redundancy and load sharing.

There are two power supply slots (PSU1 on top and PSU2 on the bottom).

- If you only have one power supply, you can install it in either PSU1 or PSU2.
- If you install a second power supply, neither one acts as a primary power supply. The two power supplies load share equally.

Before you begin

- If you are replacing an installed power supply, see [Removing a power supply](#) on page 63.
- Remove the power cord before installing or removing the power supply.

*** Note:**

The design of the latch mechanism that secures the power supply enforces this safety practice.

Procedure

1. Remove the two screws that secure the filler panel to the chassis. (Save the filler panel for possible future use.)

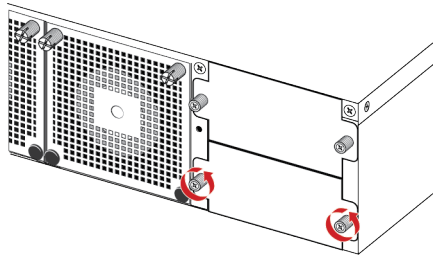

2. Slide the power supply into the slot.

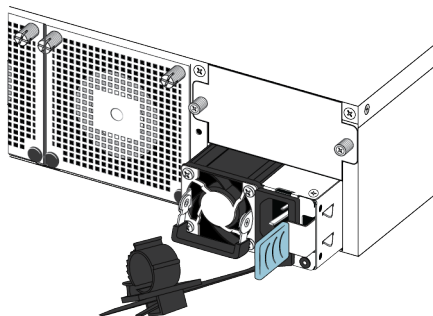

3. Verify that the power supply is fully seated in the slot. The spring latch should engage and return to its original position.

*** Note:**

The chassis design prevents an incorrect installation of a power supply. If you insert a power supply upside down, it will not fully insert.

4. Once you install a power supply, you can connect the AC power cord to the power supply on the back of the switch, and then connect the cord to an AC power outlet.

! Important:

The Avaya Virtual Services Platform 8000 Series does not have an AC power switch. When you connect the power cord to a power supply and connect the cord to an AC power outlet, the switch powers up immediately. To verify that the power supply is operating, check the LED on the bottom right side of the power supply. Solid green indicates that power is on. If it is off, check the connections.

! Warning:

Disconnecting the AC power cord is the only way to turn off AC power to the Avaya Virtual Services Platform 8000 Series. Allow at least 30 seconds for the Avaya Virtual Services Platform 8000 Series to fully power down before restoring power. Otherwise, the Avaya Virtual Services Platform 8000 Series might produce a core file during the reset leading to an extra delay during boot time. Always connect the AC power cord in a location that is quickly and safely accessible in case of an emergency. For a translation of this statement, see [Translations of safety messages](#) on page 71.

5. Check the LED on the bottom right side of the power supply. If it is off, the power supply is not operating. If it is green, the power supply is operating normally.

! Important:

You can hot swap power supplies while the switch is operational. One power supply is required for continued switch operation.

AC power supply specifications

The Avaya Virtual Services Platform 8000 Series comes with an 800 W AC power supply and you can install a secondary power supply for redundancy.

! Important:

You must have either a power supply or a power supply cover in each bay to ensure proper ventilation. Leaving a power supply bay unpopulated or uncovered impairs the ability of the fans to cool the chassis.

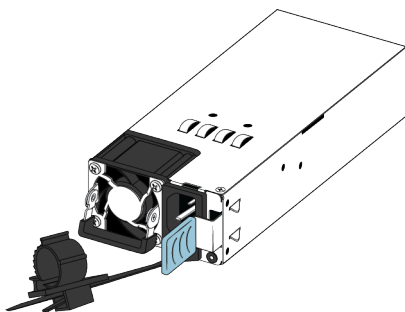

Figure 9: AC power supply

The 800 W AC power supply uses an IEC 60320 C16 AC power cord connector. The AC power cord is in close proximity to the hot air exhaust, and supports high operating temperatures.

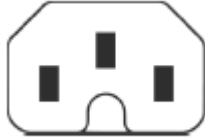

Figure 10: IEC 60320 C16 connector

The following table describes the regulatory AC power specifications for the Avaya Virtual Services Platform 8000 Series. Note that regulatory power specifications are based on the maximum rated capacity of the power supplies and are not based on typical power consumption, which is typically lower.

Table 10: AC power specifications

	VSP 8000 Series
Input Current:	9.9–4.79 A
Input Voltage (rms):	100–240 V, 47–63 Hz
Power Consumption:	800 W maximum
Thermal Rating:	2730 BTU/Hr maximum
Inrush Current:	40 A maximum
Turn on Condition:	1 second maximum after application of AC power
<p>! Important: 12 V output rise time, from 10 to 90 percent, must be the maximum of 50 ms and monotonic under all defined input and output conditions.</p>	
Efficiency:	70 percent minimum

AC power cord specifications

To connect AC power to the switch, you need an appropriate AC power cord as described in the following table, also see the following table for plug specifications.

Table 11: International power cord specifications





Country and Plug Specification	Specifications	Typical Plug
Continental Europe: • CEE7 standard VII male plug • Harmonized cord (HAR marking on the outside of the cord jacket to comply with the CENELEC Harmonized Document HD-21)	• 220 or 230VAC • 50 Hz • Single phase	

Table continues...

Country and Plug Specification	Specifications	Typical Plug
United States of America, Canada, and Japan: <ul style="list-style-type: none"> • NEMA5-15P male plug • UL-recognized (UL stamped on cord jacket) • CSA-certified (CSA label secured to the cord) 	<ul style="list-style-type: none"> • 100 or 120VAC • 50–60 Hz • Single phase 	
United Kingdom: <ul style="list-style-type: none"> • BS1363 male plug with fuse • Harmonized cord 	<ul style="list-style-type: none"> • 240VAC • 50 Hz • Single phase 	
Australia: <ul style="list-style-type: none"> • AS3112-1981 male plug 	<ul style="list-style-type: none"> • 240VAC • 50 Hz • Single phase 	

⚠ Danger:

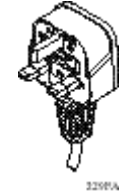
Using power cords with a proper grounding path

Use only power cords that have a grounding path. Without a proper ground, a person who touches the switch is in danger of receiving an electrical shock. Lack of a grounding path to the switch can result in excessive emissions. For a translation of this statement, see [Translations of safety messages](#) on page 71.

DC power supply

Installing a DC power supply

! Important:

Avaya does not support installing a combination of AC-input and DC-input power supplies in the same chassis.

The Avaya Virtual Services Platform 8000 Series supports two field-replaceable 800 W power supplies. One comes with the switch and you can install a second power supply to provide redundancy and load sharing.

There are two power supply slots (PSU1 on top and PSU2 on the bottom).

- If you only have one power supply, you can install it in either PSU1 or PSU2.
- If you install a second power supply, neither one acts as a primary power supply. The two power supplies load share equally.

Before you begin

- If you are replacing an installed power supply, see [Removing a power supply](#) on page 63.
- Remove the DC power supply wiring assembly before installing or removing the power supply.

*** Note:**

The design of the latch mechanism that secures the power supply enforces this safety practice.

Procedure

1. Remove the two screws that secure the filler panel to the chassis. (Save the filler panel for possible future use.)

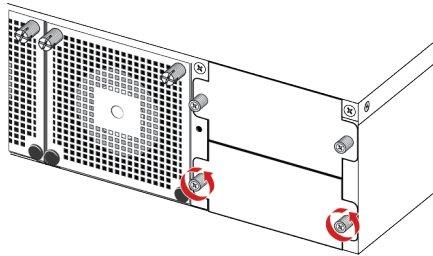

2. Slide the power supply into the slot.

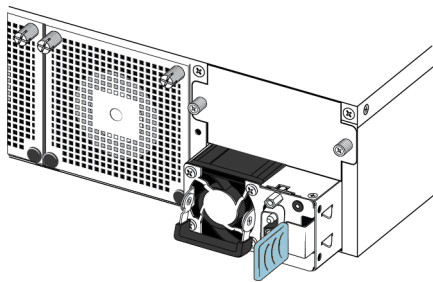

3. Verify that the power supply is fully seated in the slot. The spring latch should engage and return to its original position.

*** Note:**

The chassis design prevents an incorrect installation of a power supply. If you insert a power supply upside down, it will not fully insert.

! Important:

The Avaya Virtual Services Platform 8000 Series does not have a power switch. When you connect the DC power source to the DC power supply wiring assembly and then plug the assembly into the DC power supply, the switch powers up immediately.

! Warning:

Disconnecting the DC power supply wiring assembly from the power supply is the only way to turn off DC power to the Avaya Virtual Services Platform 8000 Series. Allow at least 30 seconds for the Avaya Virtual Services Platform 8000 Series to fully power

down before restoring power. Otherwise, the Avaya Virtual Services Platform 8000 Series might produce a core file during the reset leading to an extra delay during boot time.

4. Once you install a power supply, use the following steps to connect the DC power supply wiring assembly:
 - a. Avaya supplies a DC power supply wiring assembly to connect the DC power supply to the DC input power source.

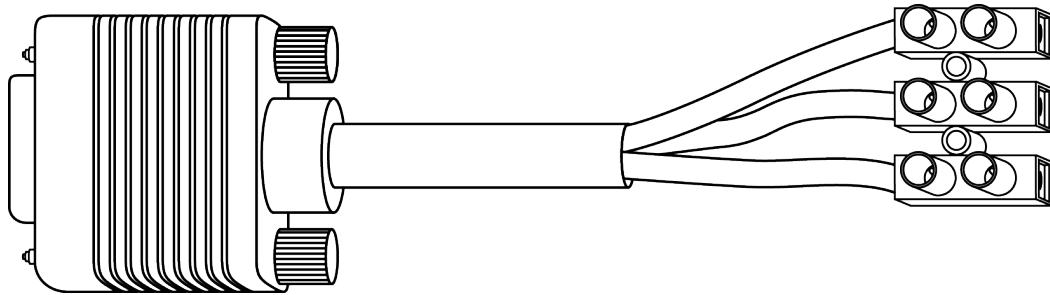

- b. Strip 0.8 in. (2 cm) of insulation from the ends of the power source cables.
 - c. Refer to the tag attached to the DC power supply wiring assembly to insert the cables into their appropriate connectors.

⚠ Voltage:

Ensure that the positive and negative power inputs are connected to the correct connectors and that the switch is properly grounded before connecting it to a power source.

- d. Use a screwdriver to crimp the cables to the DC power supply wiring assembly.

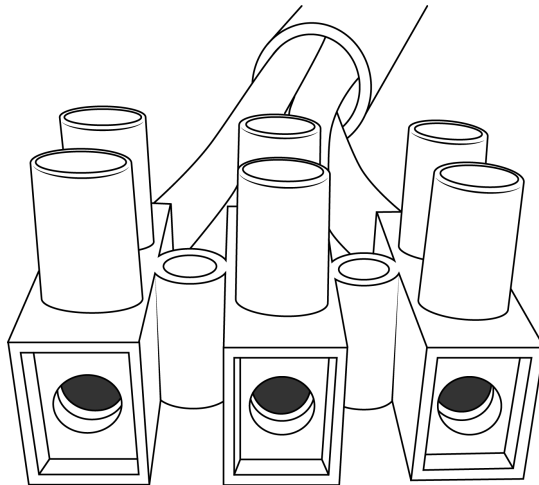

- e. Use a screwdriver to terminate the three raw wires to a DC power source.
 - f. Connect the DC power supply wiring assembly to the DC power supply and screw it in to secure the connection.

5. Check the LED on the top right side of the power supply. If it is off, the power supply is not operating. If it is green, the power supply is operating normally. The following table describes all the LED states.

Table 12: DC power supply LED states

Color and Status	Description
Off	There is no DC power to either power supply.
Green (steady)	There is output and the power supply is operating normally.
Green (blinking)	The power supply is present, but its output is standby voltage (12VSB).
Amber (steady)	SHUTDOWN: The power supply is not supplying power to the switch because the power cord is unplugged or the power supply shutdown for faults such as a fan failure or exceeding limits for Over Current Protection (OCP) or Over Voltage Protection (OVP).
Amber (blinking)	WARNING: The power supply continues to operate, but there are one or more warning events such as high temp, high power, high current, or a slow fan.

! Important:

You can hot swap power supplies while the switch is operational. One power supply is required for continued switch operation.

DC power supply specifications

The Avaya Virtual Services Platform 8000 Series comes with one 800 W DC power supply and you can install a secondary power supply for redundancy.

! Important:

You must have either a power supply or a power supply cover in each bay to ensure proper ventilation. Leaving a power supply bay unpopulated or uncovered impairs the ability of the fans to cool the chassis.

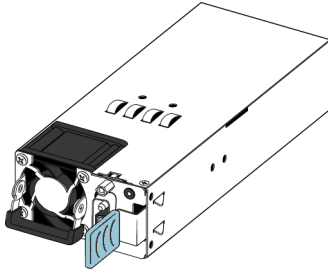

Figure 11: DC power supply

The 800 W DC power supply uses a DC power supply wiring assembly to connect the power supply to the DC power source.

The following table describes the regulatory DC power specifications for the Avaya Virtual Services Platform 8000 Series switch. Note that regulatory power specifications are based on the maximum rated capacity of the power supplies and are not based on typical power consumption, which is typically lower.

Table 13: DC power specifications

	VSP 8000 Series
Input Current:	24–16 A
Input Voltage (rms):	40.5 to 60 VDC
Power Consumption:	800 W maximum
Temperature:	Operating range: 0 to 50° C Non-operating range: -40 to 70° C
Inrush Current:	50 A maximum
Turn on Condition:	500 milliseconds maximum after application of DC power
<p>! Important: 12 V output rise time, from 10 to 90 percent, must be the maximum of 70 ms and monotonic under all defined input and output conditions.</p>	
Efficiency:	<ul style="list-style-type: none"> • 88% minimum at 100% load level • 92% minimum at 50% load level • 88% minimum at 20% load level • 80% minimum at 10% load level

Removing a power supply

You can hot swap power supplies while the switch is operational.

Procedure

1. Disconnect the power cord from the power supply.
2. Lift up the power supply handle so you can grasp it.
3. Push the spring latch to the left and use the power supply handle to pull the power supply out of the chassis.
4. If you are replacing the power supply, see [Installing a power supply](#) on page 55. If not, re-install the filler panel.

Airflow direction

The airflow direction for Avaya Virtual Services Platform 8200 and Avaya Virtual Services Platform 8400 is front-to-back.

Installing a fan tray

The Avaya Virtual Services Platform 8000 Series comes with four 12-V fan trays for switch cooling.

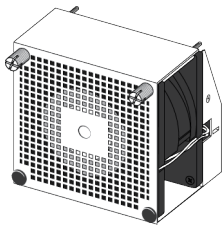

Figure 12: Fan tray

There are four sensors inside the chassis that monitor the temperature. These sensors send information to a controller that automatically regulates the fan speed to maintain the proper temperature. If any sensor exceeds its threshold, an alarm is sent. When the temperature cools by 2° below the threshold, the alarm clears.

Use this procedure if a fan fails and you have to replace it.

! Important:

All four fans must be installed at all times to ensure proper ventilation. If a fan fails, replace it as soon as you can but leave it in place until you do. Leaving a fan bay unpopulated impairs the ability of the remaining fans to cool the chassis.

Procedure

1. Check the Fan LED on the front of the chassis. Solid green indicates that all fan trays are operating normally. Blinking amber indicates that a fan tray failed.

2. Enter the following command to determine which fan tray failed.

```
show sys-info fan
```

This command shows the status of each fan tray: up, down, or Not Present when a fan is removed.

3. Remove the fan tray that failed by loosening the two thumb screws and pulling the fan tray out of the chassis.

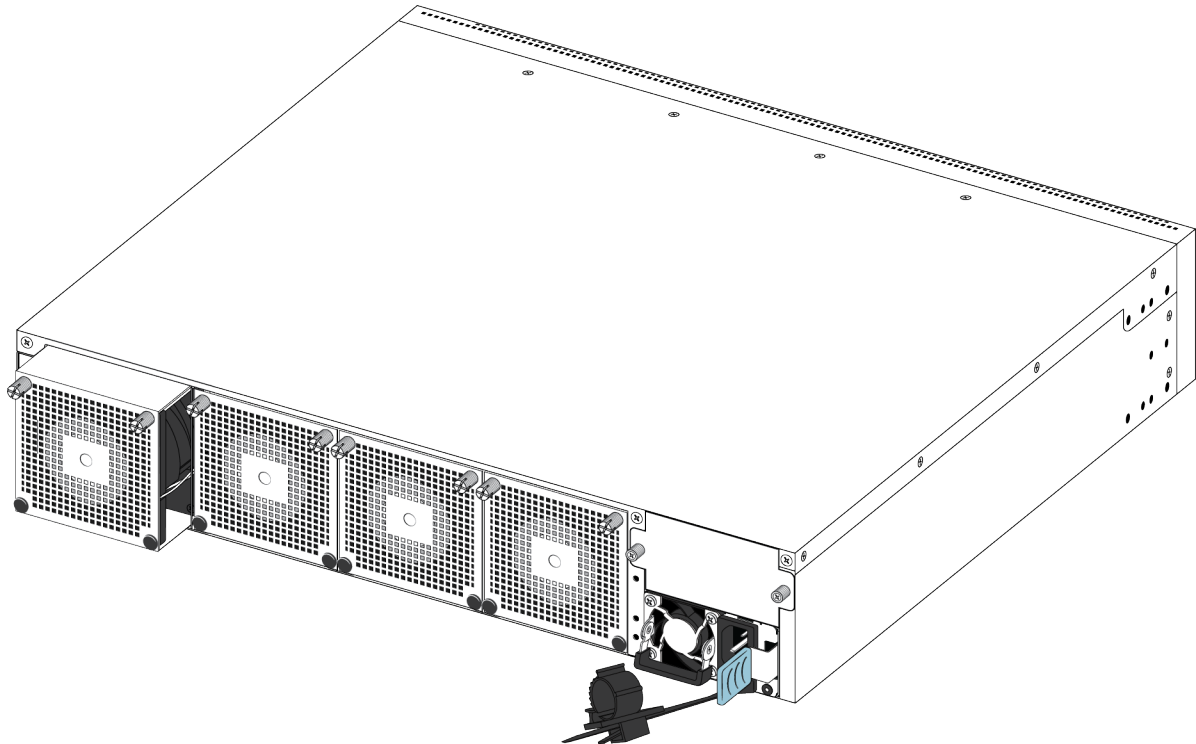

4. Insert the new fan tray into the chassis.

! Important:

You can hot swap fan trays while the switch is operational.

5. Verify that the fan tray is fully seated in the chassis and secure it with two thumb screws.
6. Enter the following command to check the temperature sensors inside the switch.

```
show sys-info temperature
```

Example

Check the status of the fan trays.

```
VSP-8000:1>show sys-info fan
Fan Info :
Fan Id   Fan Status   Fan Type
-----
1        up           regularSpeed
2        up           regularSpeed
3        up           regularSpeed
```

```
4          up          regularSpeed
```

Check the internal temperature of the switch.

```
VSP-8000:1>show sys-info temperature
Temperature Info :
  CPU Temperature      MAC Temperature      PHY1 Temperature      PHY2 Temperature
    26                 29                   24                    27
```

LED state definitions

The figures and tables in the following sections describe the LEDs on the Avaya Virtual Services Platform 8000 Series switch. The tables describe LED operation for a switch that finishes the power-on self-test.

Warning:

Fiber optic equipment can emit laser or infrared light that can injure your eyes. Never look into an optical fiber or connector port. Always assume that fiber-optic cables are connected to a light source.

Switch LEDs

The following table describes the main switch LED state indications provided by LED color and fluctuation cues.

Table 14: Switch LED state indicators

Label	Color and Status	Description
PWR	Off	The switch is not receiving power and not operating.
	Green (steady)	The switch is receiving power from either one of the power supplies (if two power supplies are installed).
Status	Off	The switch is non-operational.
	Amber (steady)	The switch encountered an error when running the diagnostic software.
	Amber (blinking)	The switch is booting and running diagnostic software. This is normal activity during the boot process.
	Green (steady)	The switch loaded the agent software code and is operating normally.
	Green (blinking)	The switch is loading the agent software code.
RPS	Off	A second power supply is not present in either PSU1 or PSU2.
	Amber (steady)	The second power supply in PSU1 or PSU2 is removed.

Table continues...

Label	Color and Status	Description
	Amber (blinking)	The second power supply, which was operating in PSU1 or PSU2, is either a fault condition or a PSU is present but not supplying power.
	Green (steady)	The second power supply (in either PSU1 or PSU2) is present and operating normally as a redundant power supply (RPS).
Fan	Amber (steady)	A fan tray has been removed.
	Amber (blinking)	A fan tray has failed.
	Green (steady)	All fan trays are operating normally.

Management port LED state indicators

This section describes the management port LED state indicators by color and fluctuation cues. The management port uses two bi-colored LEDs to indicate the activity and speed of the link.

- The LED on the left side of the port (**Speed**) indicates the current speed of the port.
- The LED on the right side of the port (**Link/Act**) indicates the status of the link and whether or not it's active.

Table 15: Management port LED state indicators

Label	Color and Status	Description
Speed	Off	The port is operating at 10 Mbps.
	Amber (steady)	The port is operating at 100 Mbps.
	Green (steady)	The port is operating at 1 Gbps.
Link/Act	Off	N/A
	Amber (steady)	The port admin is disabled.
	Amber (blinking)	The port is not in use.
	Green (steady)	The port has no data activity.
	Green (blinking)	The port has data activity.

SFP, SFP+, and QSFP+ port LED state indicators

This section describes the transceiver port LED state indicators by color and fluctuation cues.

SFP, SFP+ port LED state indicators

These ports use the LED on the left side of the port (**Link/Act**) to indicate whether or not the link is established and if a transceiver is present and active.

Table 16: SFP/SFP+ port LED state indicators

Label	Color and Status	Description
Link/Act	Off	There is no transceiver present and the port is administratively enabled.
	Amber (blinking)	The port received a remote fault indicator (RFI).
	Amber (steady)	The port is actively transmitting, but there is no link. This indicates a local fault.
	Green (steady)	The port has established a link.
	Green (blinking)	The port has established a link and there is data activity.
	Green (slow blinking)	The port is administratively disabled.
In Use	Off	Link down
	Green (blinking)	Operating at 1Gbps link speed
	Green (Solid)	Operating at 10Gbps link speed

QSFP+ port LED state indicators

The QSFP+ used in the system includes one bi-colored (amber/green) LED per port. The bi-colored LED is located in the transceiver cage. The bi-colored LED is labeled as “Link/Act”. The following table defines the operation of the QSFP+ LEDs:

Table 17: QSFP+ port LED state indicators

Label	Color and Status	Description
Link/Act	Off	There is no transceiver present and the port is administratively enabled.
	Amber (blinking)	The port received a remote fault indicator (RFI).
	Amber (steady)	The port is actively transmitting, but there is no link. This indicates a local fault.
	Green (steady)	The port has established a link.
	Green (blinking)	The port has established a link and there is data activity.
	Green (slow blinking)	The port is administratively disabled or the transceiver has been removed.
In Use or Opt	Off	Clear channel mode
	Green (Solid)	Channelized mode of operation

Port LED state indicators

The RJ45 ports used in the system have single LED labelled as “Link/Activity”. The following table shows the status of the one LED:

Table 18: 100/1G/10G RJ45 port LED state indicators

Label	Color and Status	Description
Link/Activity	Off	The port does not have link.
	Blue (solid)	The port has link in 10Gbps mode.
	Blue (blinking)	The port has link and data activity in 10Gbps mode.
	Amber (solid)	The port has link in 100Mbps mode.
	Amber (blinking)	The port has link and data activity in 100Mbps mode.
	Green (solid)	The port has link in 1Gbps mode.
	Green (blinking)	The port has link and data activity in 1Gbps mode.
	Green (slow blinking)	The port is administratively disabled.

Channelized LED state indicators

The following table describes the channelization LED state indications provided by the color. These ports use **In Use Link/Act** to indicate whether or not the link is established.

Table 19: Channelized LED state indicators



Label	Color and Status	Description
In Use	Off	Clear channel (40GB) mode of operation
	Green (solid)	Channelized mode of operation
Link/Act	Off	All ports are link down, no faults
	Amber (blinking)	One or more ports have local fault
	Amber (steady)	One or more ports have remote fault
	Green (slow blinking)	One or more ports are administratively down <p> Note: Remote fault has priority over local fault Local fault has priority over administratively down</p>

Table continues...

Label	Color and Status	Description
	Green (steady)	At least one port has link up, no activity, no faults
	Green (blinking)	At least one port has link up and activity, no faults  Note: Administratively down has priority over link up.

Enterprise Device Manager (EDM) representation of physical LED status

EDM displays the same LEDs that you see on the physical device.

 **Note:**

LED blinking in EDM is representative of, but not identical to, the actual LED blinking rates on the switch.

For more information about the LEDs and a description of the blinking rates, see the preceding LED sections.

40GBASE-QSFP+ ports

When a 40 Gigabit port is channelized, only use break out cables (DAC or Fiber) in it. Otherwise, the link behavior can be unpredictable because it can result in mismatched link status between link partners, which can further lead to network issues.

Also avoid the use of break out cables in non-channelized 40 Gigabit ports because this can result in mismatched link status between link partners, which can lead to network issues.

Chapter 6: Translations of safety messages

 **Caution:**

When you mount this device in a rack, do not stack units directly on top of one another. You must secure each unit to the rack with appropriate mounting brackets. Mounting brackets cannot support multiple units.

 **Important:**

Achtung:

Wenn diese Einheit in einem Rack montiert wird, muß ein gewisser Abstand zur nächsten Einheit gelassen werden. Jede Einheit muß mit geeignetem Befestigungsmaterial gesichert werden. Das Befestigungsmaterial ist nicht für die gleichzeitige Befestigung mehrerer Einheiten geeignet.

 **Important:**

Si vous installez le module dans une baie, ne l'empilez pas directement sur un autre. Chaque module doit être fixé à sa propre baie à l'aide des supports de montage appropriés. Ces supports ne sont pas conçus pour résister à plusieurs modules.

 **Important:**

Precaución:

Cuando monte este dispositivo en un bastidor, no apile las unidades directamente una encima de otra. Cada unidad debe fijarse en el bastidor con las abrazaderas de montaje adecuadas. Las abrazaderas de montaje no están diseñadas para sostener varias unidades.

 **Important:**

Se il dispositivo viene installato in un rack, non impilare le unità direttamente una sull'altra. Ogni unità deve essere fissata al rack con le staffe di montaggio appropriate. Le staffe di montaggio non sono state progettate per supportare più unità.



警告: 在机架中安装此设备时, 请勿将多个部件叠放在机架中。必须用合适的安装托架将各个部件固定在机架中。安装托架无法支撑多个部件。



注意: この装置をラックに設置する場合は、ラック内のユニットを直接積み重ねないようにしてください。各ユニットは専用の取り付けブラケットでラックに固定する必要があります。取り付けブラケットは複数のユニットを支えるようには設計されていません。



注意：在機箱中掛載此裝置時，請不要直接在機箱中的另一個裝置上直接堆放裝置。每一裝置都必須使用適當的掛載托架以固定在機架中。掛載托架不能用來支撐多個裝置。

 **Caution:**

If you are not installing a module in the slot, be sure to keep the metal cover plate in place over the slot. Removing the cover plate impedes airflow and proper cooling of the unit.

 **Important:**

Achtung:

Wenn Sie kein Modul im Schacht verwenden, muß die Metallabdeckung über dem Schacht montiert sein. Eine Entfernung der Abdeckung führt zu einer Verschlechterung der Luftzirkulation und damit zu einer nicht ausreichenden Kühlung der Einheit.

 **Important:**

Si vous n'installez pas le module dans une baie, veuillez à laisser la plaque métallique sur la baie. Si vous la retirez, l'aération du module ne peut pas s'effectuer correctement.

 **Important:**

Precaution:

Si no instala ningún módulo en la ranura, asegúrese de mantener la placa de la cubierta de metal en la misma. Si la retira, impedirá que el aire circule y la unidad se refrigere adecuadamente.

 **Important:**

Attenzione:

Se nello slot non vengono installati moduli, assicurarsi di mantenere la piastra di copertura metallica in sede sopra lo slot. La rimozione della piastra impedisce la ventilazione e il corretto raffreddamento dell'unità.



注意：この装置をラックに設置する場合は、ラック内のユニットを直接積み重ねないようにしてください。各ユニットは専用の取り付けブラケットでラックに固定する必要があります。取り付けブラケットは複数のユニットを支えるようには設計されていません。



注意：スロットにモジュールを取り付けない場合は、スロットにある金属製のカバープレートが外れないように注意してください。カバープレートを動かすと airflow が妨げられ、適切なユニット冷却が行われなくなります。



注意：如果您未在插槽中安裝模組，請確定金屬殼板正確地蓋在插槽上。移除殼板會阻礙空氣流通以及裝置的適當冷卻度。



警告：如果您不打算在该插槽中安装任何模块，请务必使金属盖板正确地盖住该插槽。如果取下盖板，将妨碍通风及部件散热。



警告：この装置の電源は、電源コードを抜かない限り切断できません。緊急の場合にすばやく安全に切断できる場所に電源コードを接続してください。



警告：若要關閉此裝置的電源，拔掉插頭是唯一的方法。爲了因應緊急狀況，請將電源線連接到可以快速插拔的地方。

 **Warning:**

Disconnecting the AC power cord is the only way to turn off AC power to this device. Allow at least 30 seconds for the this device to fully power down before restoring power. Otherwise, this device might produce a core file during the reset leading to an extra delay during boot time. Always connect the AC power cord in a quickly and safely accessible location in case of an emergency.

 **Important:**

Warnung:

Das Gerät kann nur durch Ziehen des Netzsteckers ausgeschaltet werden. Schließen Sie das Netzkabel an einer Steckdose an, die in Notfällen schnell und sicher zugänglich ist.

 **Important:**

Avertissement:

Pour mettre le module hors tension, vous devez impérativement déconnecter le cordon d'alimentation. En outre, vous devez dégager un espace minimal dans la zone de câblage pour pouvoir y accéder facilement en cas d'urgence.



警告：断开交流电源线是切断本设备的交流电源的唯一方法。交流电源线一定要连接到在紧急时刻可以快速安全地接触到的位置。

 **Important:**

Advertencia:

Para apagar el dispositivo debe desenchufar el cable. Conecte siempre el cable de alimentación a una toma segura y de fácil acceso por si se produjera alguna situación de emergencia.

 **Important:**

Avviso:

L'unico modo per disattivare questo dispositivo consiste nello scollegare il cavo di alimentazione. Collegare sempre il cavo di alimentazione ad una presa che sia facilmente e rapidamente accessibile in caso di emergenza.

 **Danger:**

Use only power cords that have a grounding path. Without a proper ground, a person who touches the switch is in danger of receiving an electrical shock. Lack of a grounding path to the switch can result in excessive emissions.

! Important:

Vorsicht:

Verwenden Sie nur Netzkabel mit Schutzerdung. Ohne ordnungsgemäße Schutzerdung besteht für Personen, die den Switch berühren, die Gefahr eines elektrischen Schlages. Eine nichtvorhandene Schutzerdung kann zu sehr starken Abstrahlungen führen.

⚠ Danger:

N'utilisez que des cordons d'alimentation équipés de trajet de mise à la terre. Sans mise à la terre adaptée, vous risquez de recevoir une décharge électrique en touchant le commutateur. Par ailleurs, l'absence de trajet de mise à la terre peut générer des émissions excessives.

! Important:

Peligro:

Utilice únicamente cables de alimentación con toma de tierra. De lo contrario, al tocar el interruptor puede recibir una descarga eléctrica. Si no hay un circuito de toma de tierra en el enchufe, puede producirse un exceso de emisiones.

! Important:

Pericolo:

Utilizzare esclusivamente cavi di alimentazione dotati di un percorso per la messa a terra. Senza un'adeguata messa a terra, chiunque tocchi lo switch corre il rischio di ricevere una scossa elettrica. L'assenza di un percorso per la messa a terra verso lo switch può comportare un eccesso di emissioni.



危険: 接地経路を持つ電源コードを必ず使用するようになしてください。適切な接地がない状態でスイッチに触ると、感電する危険性があります。また、スイッチへの接地経路がないと、過度な放電を引き起こす可能性があります。



危险: 请仅使用接地的电源线。如果电源线不接地或接地不当, 接触交换机的人员可能会受到电击。如果交换机不接地, 则可能导致放电过量。

⚠ Warning:

The lithium battery is not field replaceable. It should be removed and replaced by authorized personnel only. Contact Avaya Technical Support for assistance if the battery requires replacement.