

53-0000070-02
16 July, 2013



Brocade MLXe Series

Hardware Installation Guide

Supported Release: Multi-Service IronWare R05.5.00

BROCADE

Copyright © 2006-2013 Brocade Communications Systems, Inc. All Rights Reserved.

ADX, AnyIO, Brocade, Brocade Assurance, the B-wing symbol, DCX, Fabric OS, ICX, MLX, MyBrocade, OpenScript, VCS, VDX, and Vyatta are registered trademarks, and HyperEdge, The Effortless Network, and The On-Demand Data Center are trademarks of Brocade Communications Systems, Inc., in the United States and/or in other countries. Other brands, products, or service names mentioned may be trademarks of their respective owners.

Notice: This document is for informational purposes only and does not set forth any warranty, expressed or implied, concerning any equipment, equipment feature, or service offered or to be offered by Brocade. Brocade reserves the right to make changes to this document at any time, without notice, and assumes no responsibility for its use. This informational document describes features that may not be currently available. Contact a Brocade sales office for information on feature and product availability. Export of technical data contained in this document may require an export license from the United States government.

The authors and Brocade Communications Systems, Inc. shall have no liability or responsibility to any person or entity with respect to any loss, cost, liability, or damages arising from the information contained in this book or the computer programs that accompany it.

The product described by this document may contain "open source" software covered by the GNU General Public License or other open source license agreements. To find out which open source software is included in Brocade products, view the licensing terms applicable to the open source software, and obtain a copy of the programming source code, please visit <http://www.brocade.com/support/oscd>.

Brocade Communications Systems, Incorporated

Corporate and Latin American Headquarters
Brocade Communications Systems, Inc.
130 Holger Way,
San Jose, CA 95134
Tel: 1-408-333-8000
Fax: 1-408-333-8101
E-mail: info@Brocade.com

Asia-Pacific Headquarters
Brocade Communications Systems China HK, Ltd.
No. 1 Guanghua Road
Chao Yang District
Units 2718 and 2818
Beijing 100020, China
Tel: +8610 6588 8888
Fax: +8610 6588 9999
E-mail: china-info@Brocade.com

European Headquarters
Brocade Communications Switzerland Sàrl
Centre Swissair
Tour B - 4ème étage
29, Route de l'Aéroport
Case Postale 105
CH-1215 Genève 15
Switzerland
Tel: +41 22 799 5640
Fax: +41 22 799 5641
E-mail: emea-info@Brocade.com

Asia-Pacific Headquarters
Brocade Communications Systems Co., Ltd. (Shenzhen WFOE)
Citic Plaza
No. 233 Tian He Road North
Unit 1308 - 13th Floor
Guangzhou, China
Tel: +8620 3891 2000
Fax: +8620 3891 2111
E-mail: china-info@Brocade.com

Document History

Title	Publication number	Summary of changes	Date
Brocade MLXe Series Hardware Installation Guide	53-0000070-01	Release 05.4.00 document updated with enhancements in Release 05.5.00	12 April 2013
Brocade MLXe Series Hardware Installation Guide	53-0000070-02	Release 05.5.00 document updated with enhancements in Release 05.5.00c	16 July, 2013

Contents

About This Document

Audience	ix
How this document is organized	ix
Supported hardware	ix
What's new in this document	x
Document conventions	xi
Text formatting	xi
Command syntax conventions	xi
Command examples	xi
Notes, cautions, and danger notices	xi
Notice to the reader	xii
Related publications	xii
Getting technical help	xii

Chapter 1

Product Overview

Brocade router overview	1
Router applications	1
Hardware features	1
Brocade MLXe routers	2
Router modules	8
Management modules	8
Interface modules	13
Switch fabric modules	30
High-speed switch fabric modules	31
Power supplies	32
Rack mounting brackets	33
Cooling system for Brocade MLXe routers	34
Cooling system for Brocade MLXe Series routers	38
NIBI-16-FAN-EXH-A high-speed fan assemblies	38
Rack mount kit	38
Supported software features	38

Chapter 2

Installing a Brocade MLXe Router

Pre-Installation notice for the Brocade MLXe chassis bundles	39
Installation precautions	40
General precautions	40
Power precautions	41

Installing 2x100GbE interface modules in Brocade MLXe routers .	43
Installation considerations	43
Installation procedure	43
Installing BR-MLX-10Gx24-DM interface modules in Brocade MLXe routers	46
Installation considerations	46
Installation procedure	47
Installing a Brocade MLXe-4 router	48
Preparing the installation site	48
Unpacking a Brocade MLXe-4 router	48
Installing a Brocade MLXe-4 router in a rack or cabinet	48
Installing Brocade MLXe-4 modules	50
Installing power supplies in a Brocade MLXe-4 router	53
Connecting AC power	54
Connecting DC power	55
Final steps	56
Installing a Brocade MLXe-8 router	57
Preparing the installation site	57
Unpacking a Brocade MLXe-8 router	57
Installing a Brocade MLXe-8 router in a rack	58
Installing Brocade MLXe-8 modules	60
Installing power supplies in the Brocade MLXe-8 router	63
Connecting AC power	64
Connecting DC power	65
Final steps	66
Installing a Brocade MLXe-16 router	67
Preparing the installation site	67
Unpacking a Brocade MLXe-16 router	67
Installing a Brocade MLXe-16 router in a rack	68
Installing modules in a Brocade MLXe 16-slot router	70
Installing power supplies in a Brocade MLXe-16 router	73
Connecting AC power	74
Connecting DC power	75
Final steps	77
Mounting Brocade MLXe-4, -8, or -16 routers in a 4-post rack or cabinet	77
Cabinet or 4-Post Rack Mount Kit contents	77
Installing Brocade MLXe-4 and Brocade MLXe-8 routers in a cabinet or 4-post rack	77
Installing a Brocade MLXe-16 router in a cabinet or 4-post rack	82

Installing a Brocade MLXe-32 router	86
Preparing the installation site	86
Brocade MLXe-32 router shipping carton contents	86
Unpacking your Brocade MLXe-32 router	86
Installing a Brocade MLXe-32 router in a rack	88
Installing modules in the Brocade MLXe-32 router	105
Brocade MLXe-32 cable management	108
Accessing modules for service	116
Installing power supplies in a Brocade MLXe-32 router	118
Connecting AC power	120
Connecting DC power	120
Removing Brocade MLXe-32 router DC power supplies	122
Final steps	123
Attaching a management station	123
Attaching a PC or terminal to the console port or Ethernet port	123
Activating the power source	124
Verifying proper operation	125
Observing the LEDs	125
Displaying the module status	128

Chapter 3

Using Brocade Structured Cabling Components

Cable cinch overview	131
mRJ21 procedures	131
Cable cinch with two mRJ21 cables	132
Cable cinch with three mRJ21 cables	132
Cable cinch with four mRJ21 cables	133
Cable cinch with five mRJ21 cables	133
Cable cinch with six mRJ21 cables	134
Cable cinch with seven mRJ21 cables	134
Cable cinch with eight mRJ21 cables	135
RJ45 procedures	135
Cable cinch with one group of RJ45 cables	135
Cable cinch with two groups of RJ45 cables	136
Cable cinch with three groups of RJ45 cables	136
Cable cinch with four groups of RJ45 cables	137
Cable cinch with five groups of RJ45 cables	137
Cable cinch with six groups of RJ45 cables	138
Cable cinch with seven groups of RJ45 cables	138
Cable cinch with eight groups of RJ45 cables	139

Chapter 4

Connecting a Router to a Network Device

Assigning permanent passwords	141
-------------------------------------	-----

Configuring IP addresses	142
Support of subnet masks	143
Assigning an IP address to a management interface	143
Assigning IP addresses to an interface, virtual interface, or loopback interface.	144
Enabling and disabling the interfaces	145
Understanding management port functions.	145
Connecting the router to a network device	145
Installing a fiber-optic transceiver.	146
Cabling a fiber-optic transceiver	146
Cleaning fiber-optic ports and connectors.	147
Troubleshooting network connections	147
Testing network connectivity	148
Pinging an IP address	148
Tracing a route	149

Chapter 5

Managing Routers and Modules

Managing the device.	151
Disabling and re-enabling power to interface modules.	151
Monitoring I2C failures on management modules	152
Displaying device status and temperature readings.	154
Displaying the Syslog configuration and static and dynamic buffers 157	
Managing switch fabric modules	159
Forcing HSF modules to operate in normal mode.	160
Blocking discovery of G1 switch fabric modules	160
Managing the cooling system.	161
Configuring the cooling system.	161
Manually setting the fan speed	167
Monitoring the cooling system	168
Temperature log reduction	169
Managing interface modules	170
Configuring interface module boot parameters.	170
Changing priority of slots for interface modules	175
Disabling and re-enabling power to interface modules.	176
Monitoring Link Status	177
Enabling monitoring link status	177
Disabling monitoring link status	177
Displaying fabric link status	177
Syslog messages	178
Using alarms to collect and monitor device status.	178
Configuring Alarm History Buffer Size	179
Configuring alarm logging	179
Displaying alarms.	180
Clearing the alarm history log	183
Disabling SNMP trap generation and logging	183
Displaying MR2 management module memory usage	183

Enabling and disabling management module CPU usage calculations	184
Displaying CPU usage	184
Displaying management module CPU usage	186
Removing MAC address entries	187

Chapter 6

Maintenance and Field Replacement

Hardware maintenance schedule	189
Replacing a management module	190
Installing the Compact Flash Card in an MR2 management module	190
Replacing an interface module	191
Removing and replacing an interface module	191
Replacing a switch fabric module	192
Replacing a fiber-optic transceiver	193
Cabling a fiber-optic transceiver	194
Replacing a power supply	194
Determining which power supply failed	194
Setting the threshold for power supply monitoring	194
Clearing power supply failure timestamps	195
Displaying power supply monitoring timestamps	195
Enabling a power supply shutdown	197
Powering on the power supply through the CLI	197
Replacing a power supply	198
Replacing fan assemblies	200
Replacing fan assemblies in all 32-slot routers	200
Replacing fan assemblies in 16-slot routers	203
Replacing the fan tray assembly in 4-slot and 8-slot routers	204
Replacing the air filters	206
Installing upward deflectors on fan assemblies	210

Chapter 7

Hardware Specifications

Hardware specifications for Brocade MLXe routers	215
Power specifications	215
Physical dimensions	217
Operating environment	217
Storage environment	217
Safety agency approvals	218
Electromagnetic approvals	218
Port specifications for all router models	218
Console port pin assignments	218
Management port pin assignments	219
Power cords	220

Appendix A	Brocade MLXe Chassis Bundles	
Appendix B	Regulatory Statements	
	U.S.A.	237
	Industry Canada statement	237
	Europe and Australia.....	237
	Germany.....	237
	Japan	238
	Power cords (Japan Denan)	239
	China	239
	Taiwan	240
	Korea	240
	Russia	240
	Brazil	241
Appendix C	Caution and Danger Notices	
	Cautions.....	243
	Dangers	255

About This Document

Audience

This document is designed for system administrators with a working knowledge of Layer 2 and Layer 3 switching and routing.

If you are using a Brocade device, you should be familiar with the following protocols if applicable to your network – IP, RIP, OSPF, BGP, IS-IS, IGMP, PIM, MPLS, and VRRP.

How this document is organized

This document is organized to help you find the information that you want as quickly and easily as possible.

The document contains the following components:

- [Chapter 1, “Product Overview,”](#) provides an overview of Brocade MLXe Series routers.
- [Chapter 2, “Installing a Brocade MLXe Router,”](#) provides installation instructions for Brocade MLXe routers.
- [Chapter 3, “Using Brocade Structured Cabling Components,”](#) provides information on how to use the cabling components with Brocade MLXe Series routers.
- [Chapter 4, “Connecting a Router to a Network Device,”](#) describes how to connect Brocade MLXe Series routers to network devices.
- [Chapter 5, “Managing Routers and Modules,”](#) provides information on management tasks for Brocade MLXe Series routers.
- [Chapter 6, “Maintenance and Field Replacement,”](#) describes maintenance procedures for Brocade MLXe Series routers.
- [Chapter 7, “Hardware Specifications,”](#) provides hardware specifications for Brocade MLXe Series routers.
- [Appendix A, “Brocade MLXe Chassis Bundles,”](#) provides a list of FRU bundle contents for the Brocade MLXe routers.
- [Appendix B, “Regulatory Statements,”](#) contains regulatory information for Brocade MLXe Series routers.
- [Appendix C, “Caution and Danger Notices,”](#) contains Caution and Danger notices in four languages for Brocade MLXe Series routers.

Supported hardware

In instances in which procedures or parts of procedures documented here apply to some devices but not to others, this guide identifies exactly which devices are supported and which are not.

How this document is organized

Although many different hardware configurations are tested and supported by Brocade Communications Systems, Inc., documenting all possible configurations and scenarios is beyond the scope of this document.

The following hardware platforms are described in this document:

- Brocade MLXe-4 router
- Brocade MLXe-8 router
- Brocade MLXe-16 router
- Brocade MLXe-32 router

What's new in this document

This document has been updated for this release to include the following new information:

- new 24 port 10G module support for MLXe devices

Document conventions

This section describes text formatting conventions and important notice formats used in this document.

Text formatting

The narrative-text formatting conventions that are used are as follows:

bold text	Identifies command names Identifies the names of user-manipulated GUI elements Identifies keywords Identifies text to enter at the GUI or CLI
<i>italic text</i>	Provides emphasis Identifies variables Identifies document titles
<code>code text</code>	Identifies CLI output

Command syntax conventions

Command syntax in this manual follows these conventions:

command and parameters	Commands and parameters are printed in bold.
[]	Optional parameter.
<i>variable</i>	Variables are printed in italics.
...	Repeat the previous element, for example “member [;member...]”
	Choose from one of the parameters.

Command examples

This document describes how to perform simple upgrade and configuration tasks using the command line interface (CLI), but does not describe the commands in detail. For complete descriptions of commands for Brocade MLXe Series routers, see the *Brocade MLX Series and Brocade NetIron Family Configuration Guide*.

Notes, cautions, and danger notices

The following notices and danger statements are used in this manual. They are listed below in order of increasing severity of potential hazards.

NOTE

A note provides a tip, guidance, or advice, emphasizes important information, or provides a reference to related information.



CAUTION

A Caution statement alerts you to situations that can be potentially hazardous to you or cause damage to hardware, firmware, software, or data.



DANGER

A Danger statement indicates conditions or situations that can be potentially lethal or extremely hazardous to you. Safety labels are also attached directly to products to warn of these conditions or situations.

Notice to the reader

This document may contain references to the trademarks of the following corporations. These trademarks are the properties of their respective companies and corporations.

These references are made for informational purposes only.

Corporation	Referenced Trademarks and Products
Phillips Screw Company, Inc.	Phillips
Microsoft Corporation	Internet Explorer
Mozilla Corporation	Mozilla Firefox
Sun Microsystems	Java Runtime Environment

Related publications

- <http://www.brocade.com/ethernetproducts> Multi-Service IronWare Software Upgrade Guide
- Multi-Service IronWare
- Multi-Service IronWare Software Upgrade Procedures for Brocade MLX Series and NetIron Family devices

Getting technical help

To contact Technical Support, go to <http://www.brocade.com/services-support/index.page> for the latest e-mail and telephone contact information.

Product Overview

Brocade router overview

Brocade routers provide high-performance routing to service providers, distributed enterprises, and research networks, offering the following benefits:

- Scalable multi-service IP/MPLS carrier Ethernet routers.
- 100 Gbps Ethernet, 10Gbps Ethernet and 1Gbps Ethernet wire speed ports in a single router.
- Wire-speed IPv4, IPv6, and MPLS forwarding performance.
- Comprehensive IPv4 and IPv6 routing support based on Brocade Multi-Service IronWare.
- High-availability design with redundant management modules, switch fabric modules, power supplies and fans, supporting hitless failover, hitless software upgrades, and non-stop routing.
- Advanced, scalable Metro Ethernet Layer 2 services.
- Advanced Layer 2/Layer 3 VPN and multicast capabilities support residential triple-play and business services.
- Comprehensive hardware-based security and policies.
- Advanced QoS for differentiated SLAs.

Router applications

Brocade routers are commonly deployed in the following situations:

- Layer 2 metro networks
- Multiprotocol Label Switching (MPLS) Layer 3 Virtual Private Network (VPN) service provider networks supporting multi-VRFs and RFC 2547bis
- MPLS Layer 2 VPN service provider networks supporting both Virtual Private LAN Service (VPLS) and Virtual Leased Line (VLL)
- MPLS backbone 'P' routers
- Data Centers
- Enterprise backbones

Hardware features

This section describes the major hardware components of Brocade routers. The figures in this section show the router slots where you install modules and power supplies. For installation instructions for these devices, refer to the appropriate installation chapter in this guide for your model.

Brocade MLXe routers

Brocade MLXe routers are available in the following models:

- Brocade MLXe-4: 4 interface slots (see [Figure 1](#) on page 2)
- Brocade MLXe-8: 8 interface slots (see [Figure 2](#) on page 3)
- Brocade MLXe-16: 16 interface slots (see [Figure 3](#) on page 5)
- Brocade MLXe-32: 32 interface slots (see [Figure 4](#) on page 7)

The following sections described the components you can install in the router slots. For a detailed list of components that ships with each router, refer to [Appendix A, “Brocade MLXe Chassis Bundles”](#).

Brocade MLXe-4 router components

You can install the following components in the router slots:

- Up to two management modules (one active and one redundant).
- Up to three switch fabric modules.
- Up to four interface modules.
- Up to four power supplies (AC or DC).

For a detailed list of components that ships with each router, refer to [Appendix A, “Brocade MLXe Chassis Bundles”](#).

[Figure 1](#) displays the Brocade MLXe-4 router.

FIGURE 1 Brocade MLXe-4 router

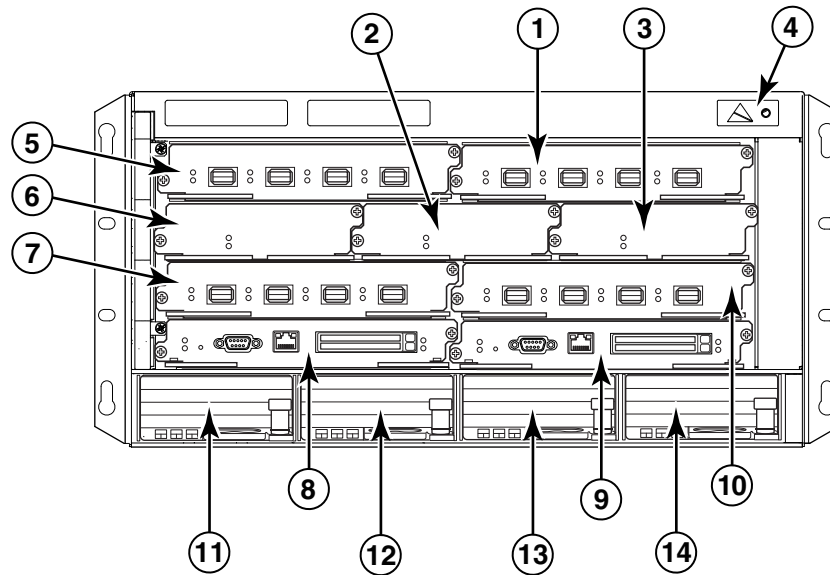

- | | | | | | | | |
|---|----------------------|---|----------------------|---|-------------------|-------|------------------|
| 1 | Interface slot 2 | 4 | ESD connector | 7 | Interface slot 3 | 10 | Interface slot 4 |
| 2 | Switch fabric slot 2 | 5 | Interface slot 1 | 8 | Management slot 1 | 11-14 | Power supplies |
| 3 | Switch fabric slot 3 | 6 | Switch fabric slot 1 | 9 | Management slot 2 | | |

Brocade MLXe-8 router components

You can install the following components in the router slots:

- Up to two management modules (one active and one redundant).
- Up to three switch fabric modules.
- Up to eight interface modules.
- Up to four power supplies (AC or DC).

For a detailed list of components that ships with each router, refer to [Appendix A, “Brocade MLXe Chassis Bundles”](#).

Figure 2 displays the Brocade MLXe-8 router.

FIGURE 2 Brocade MLXe-8 router

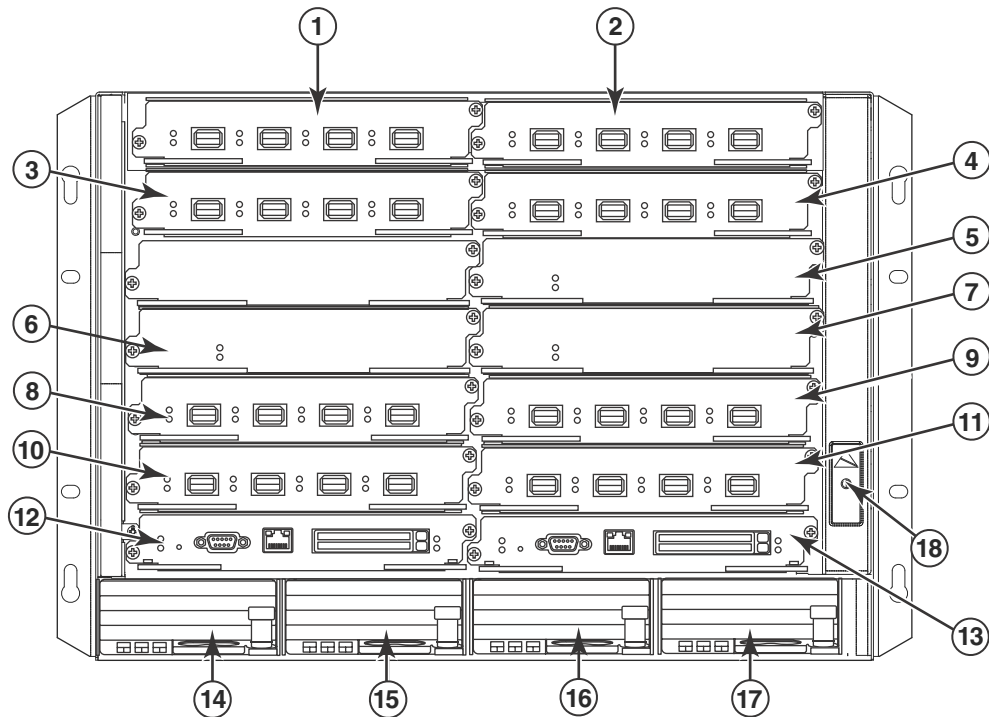

1	Interface slot 1	6	Switch fabric slot 2	11	Interface slot 8	16	Power supply slot 3
2	interface slot 2	7	Switch fabric slot 3	12	Management slot 1	17	Power supply slot 4
3	Interface slot 3	8	Interface slot 5	13	Management slot 2	18	ESD connector
4	Interface slot 4	9	Interface slot 6	14	Power supply slot 1		
5	Switch fabric slot 1	10	Interface slot 7	15	Power supply slot 2		

1 Hardware features

Brocade MLXe-16 router components

You can install the following components in the router slots:

- Up to two management modules (one active and one redundant).
- Up to four switch fabric modules.
- Up to 16 interface modules.
- Up to eight power supplies (AC or DC).

For a detailed list of components that ships with each router, refer to [Appendix A, “Brocade MLXe Chassis Bundles”](#).

Figure 3 displays the Brocade MLXe-16 router.

FIGURE 3 Brocade MLXe-16 router

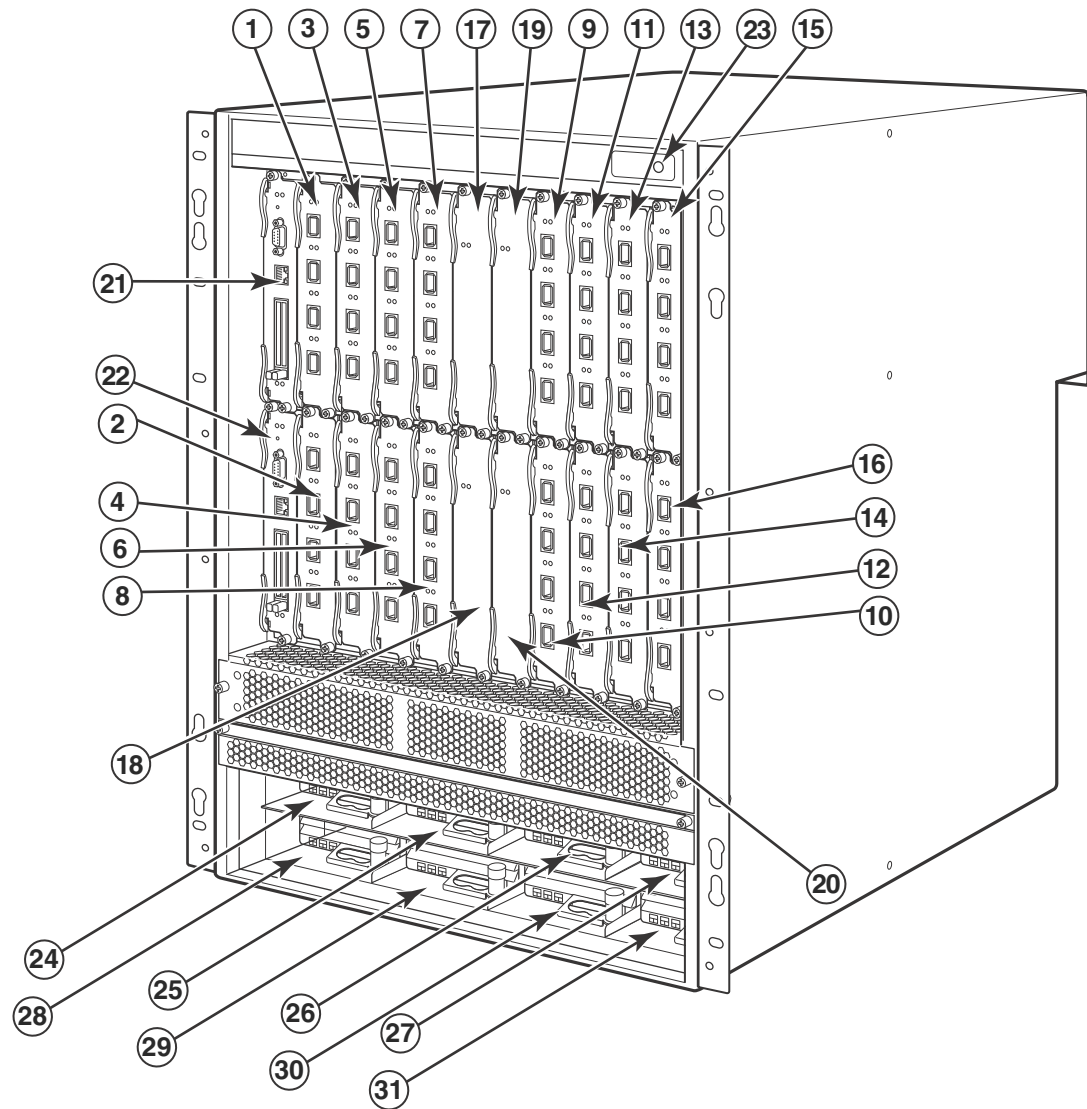

- | | | | | | |
|------|----------------------|----|----------------------|-------|----------------|
| 1-16 | Interface slots 1-16 | 20 | Switch fabric slot 4 | 24-31 | Power supplies |
| 17 | Switch fabric slot 1 | 21 | Management slot 1 | | |
| 18 | Switch fabric slot 2 | 22 | Management slot 2 | | |
| 19 | Switch fabric slot 3 | 23 | ESD connector | | |

1 Hardware features

Brocade MLXe-32 router components

You can install the following components in the router slots:

- Up to two management modules.
- Up to eight switch fabric modules.
- Up to 32 interface modules.
- Up to eight power supplies (AC or DC).

For a detailed list of components that ships with each router, refer to [Appendix A, “Brocade MLXe Chassis Bundles”](#).

Figure 4 displays the Brocade MLXe-32 router.

FIGURE 4 Brocade MLXe-32 router

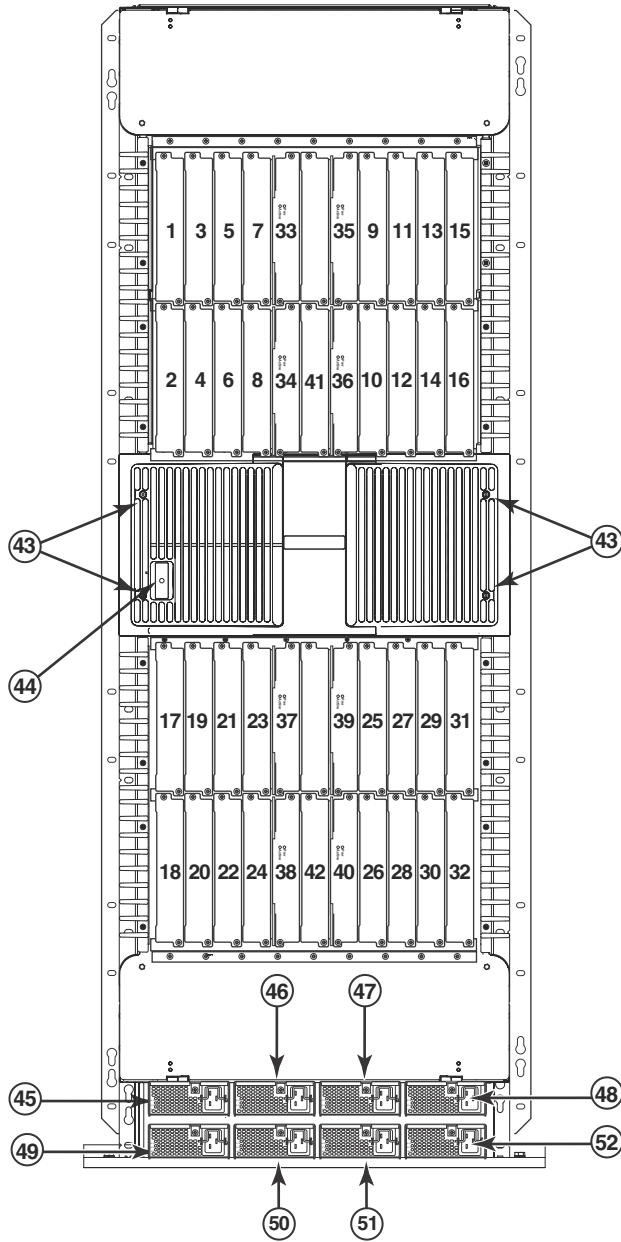

- | | | | | | | | |
|------|----------------------|----|----------------------|----|----------------|----|----------------|
| 1-32 | Interface slots 1-32 | 38 | Switch fabric slot 6 | 44 | ESD connector | 50 | Power supply 6 |
| 33 | Switch fabric slot 1 | 39 | Switch fabric slot 7 | 45 | Power supply 1 | 51 | Power supply 7 |
| 34 | Switch fabric slot 2 | 40 | Switch fabric slot 8 | 46 | Power supply 2 | 52 | Power supply 8 |
| 35 | Switch fabric slot 3 | 41 | Management slot 1 | 47 | Power supply 3 | | |
| 36 | Switch fabric slot 4 | 42 | Management slot 2 | 48 | Power supply 4 | | |
| 37 | Switch fabric slot 5 | 43 | Captive screws | 49 | Power supply 5 | | |

Router modules

This section describes management modules, interface modules, and switch fabric modules.

Management modules

Brocade MLXe routers support the following management modules types.

- MR management module
- MR2 management module

Table 1 lists the management modules available for Brocade MLXe routers.

TABLE 1 Management modules for all Brocade MLXe Series routers

Part number	Description
NI-MLX-MR	(MR) Brocade MLXe and Brocade MLX management module, 1 GB SDRAM, dual auxiliary flash slots, EIA or TIA-232 and 10/100/1000 Ethernet ports for out-of-band management.
NI-MLX-32-MR	(MR) Brocade MLXe-32 and Brocade MLX-32 management module, 1 GB SDRAM, dual auxiliary flash slots, EIA or TIA-232 and 10/100/1000 Ethernet ports for out-of-band management.
NI-XMR-MR	(MR) Brocade NetIron XMR management module, 2 GB SDRAM, dual auxiliary flash slots, EIA or TIA-232 and 10/100/1000 Ethernet ports for out-of-band management.
NI-XMR-32-MR	(MR) Brocade NetIron XMR 32000 management module, 2 GB SDRAM, dual auxiliary flash slots, EIA or TIA-232 and 10/100/1000 Ethernet ports for out-of-band management.
BR-MLX-MR2-M	(MR2) MLXe/MLX Gen2 management (M) module for 4-, 8- and 16-slot systems. Includes 4 GB RAM, 1 internal compact flash drive (2GB), 1 external compact flash slot with included 2GB card, RS-232 serial console port and 10/100/1000 Ethernet port for management.
BR-MLX-MR2-X	(MR2) MLXe/XMR Gen2 management (X) module for 4-, 8- and 16-slot systems. Includes 4 GB RAM, 1 internal compact flash drive (2GB), 1 external compact flash slot with included 2GB card, RS-232 serial console port and 10/100/1000 Ethernet port for management.
BR-MLX-32-MR2-M	(MR2) MLXe/MLX Gen2 management (M) module for 32-slot systems. Includes 4 GB RAM, 1 internal compact flash drive (2GB), 1 external compact flash slot with included 2GB card, RS-232 serial console port and 10/100/1000 Ethernet port for management.
BR-MLX-32-MR2-X	(MR2) MLXe/XMR Gen2 management (X) module for 32-slot systems. Includes 4 GB RAM, 1 internal compact flash drive (2GB), 1 external compact flash slot with included 2GB card, RS-232 serial console port and 10/100/1000 Ethernet port for management.

The management module controls the hardware components, runs the networking protocols, and provides the Real Time Operating System (RTOS).

Each router requires one management module, and can accommodate a second module for redundancy. A redundant management module works in conjunction with the active management module. If the active module becomes unavailable, the redundant management module automatically takes over the system operation, minimizing system downtime. For information about the redundancy feature, refer to the “Using a Redundant Management Module” chapter in the *Brocade MLX Series and Brocade NetIron Family Configuration Guide*.

Management modules are installed in dedicated slots marked M1 and M2. By default, the module installed in slot M1 is the active management module.

Management modules are hot-swappable, which means you can remove and replace them without powering down the system.

NOTE

MR and MR2 management modules cannot be mixed in the same chassis.

NOTE

Prior to installing or replacing the MR2 management module, you must read the Hardware Installation Notes that shipped with the hardware.

NOTE

Although management modules are designed to be hot-swappable, you must upgrade the software on all interface modules and management modules to the appropriate software release before installing them. For more information on the appropriate software release, refer to the Hardware Installation Notes that shipped with the management module.

Figure 5 shows a management module front panel.

FIGURE 5 MR management module front panel

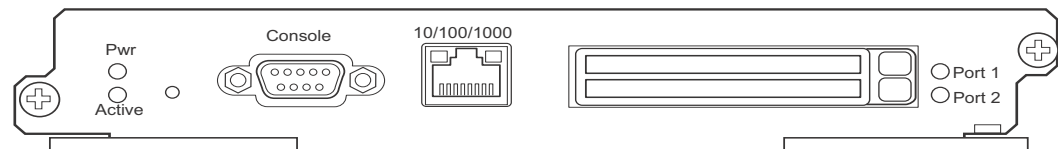
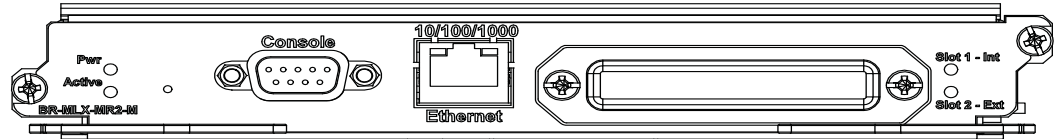

Figure 6 shows the MR2 management module front panel.

FIGURE 6 MR2 management module front panel



The front panel of the management module contains the following control features:

- Two auxiliary flash slots (available on MR management modules only)
- Compact flash slot (available on MR2 management modules only)
- Console port
- A 10/100/1000 Ethernet port
- Six LEDs

Auxiliary flash slots

Auxiliary flash slots support flash PC cards where you can store boot images, startup and running configuration files, and other system files, in addition to what is stored in system flash memory. This allows you to perform system management tasks, such as copying files between flash PC cards, or copying files between a flash PC card and flash memory.

For maximum performance, it is recommended that you use Brocade auxiliary flash cards, part number FLASH-PCC, which can be ordered from Brocade. Brocade auxiliary flash cards ship with the label on the bottom of the card; take caution to insert the card with the label on the bottom side.

NOTE

Some older auxiliary flash cards can be inserted the wrong way in the slot because there is no indication in the card about which is the right way. If you insert the card backwards, you will see continuous messages in the console and the card inserted/ card removed syslog. If this occurs, you must remove the card and reinsert it the correct way.

External compact flash

MR2 management modules do not contain an auxiliary flash slot. Instead, they contain a 2 GB internal compact flash card and an external compact flash drive. MR2 management modules come with a factory installed compact flash card in the external compact flash slot. The internal compact flash provides greater storage space for image retention, improving the upgrade process.

NOTE

Do not use compact flash cards over 2GB; they will render the system unstable.

The internal compact flash card cannot be accessed for removal or replacement.

The external compact flash slot allows you to insert a 2 GB compact flash card. If you need to replace or add an additional compact flash card, contact Brocade technical support.

Console port

The console port is a standard DB-9 serial connector through which you can attach a PC or terminal to configure the router using the CLI.

NOTE

The console port interfaces the control plane only. It does not interface the data plane.

10/100/1000 Ethernet port

Management modules also contain a 10BaseT, 100BaseTX, or 1000BaseTX auto-sensing, auto-negotiating Ethernet port. This port has an RJ45 unshielded twisted pair (UTP) connector.

Typical uses of this port include, but are not limited to, the following:

- Connecting a PC to configure, monitor, and manage the system through a Telnet or SSHv2 connection.
- Connecting to the 10BaseT, 100BaseTX, or 1000BaseTX port for connectivity to your existing management network. You can then access the router and configure, monitor, and manage the system from a management station.

NOTE

The existing management network into which you can connect the 10/100/1000 Ethernet port must be separate and isolated from the network over which user packets are switched and routed. For information about the functionality of the management port, refer to [“Understanding management port functions”](#) on page 145.

For information about connecting a PC to the 10/100/1000 Ethernet port, refer to [“Attaching a management station”](#) on page 227.

The out-of-band management port provides access to a separate system management network, and allows you to do the following tasks:

- Access the router through SSH, Telnet, the Web management interface, or the Brocade Network Advisor software.
- Access a TFTP server to perform system upgrade tasks.
- Provides SNMP polling access, as well as sending SNMP traps.
- Send Syslog packets.
- Access the system through RADIUS AAA.

Management module LEDs

The LEDs on all management module models are the same. [Table 2](#) describes the LEDs on the management module.

TABLE 2 Management module LEDs

LED	Position	State	Meaning
Port 1 and Port 2	Each adjacent to the auxiliary flash slot that it represents	On or blinking	The software is currently accessing the auxiliary flash card.
		Off	The software is not currently accessing a auxiliary flash card, although there is one inserted in the slot.
Active	Lower Left	On	The module is functioning as the active management module.
		Off	The module is functioning as the redundant management module.
Pwr	Upper Left	On	The module is receiving power.
		Off	The module is not receiving power.
10/100/1000 Ethernet Port	Above and right of RJ45 connector	On (Green)	A link is established with the remote port.
		Off	No link is established with the remote port.
10/100/1000 Ethernet Port	Above and left of RJ45 connector	On or blinking (Yellow)	The port is transmitting and receiving packets.
		Off for an extended period	The port is not transmitting or receiving packets.

Pre-Installation notice for Brocade MLXe chassis bundles with MR2 management modules

The following conditions must be met for any chassis with a MR2 management module to operate properly.

- The MR2 module requires a minimum software version of R05.2.00b to operate. Do not attempt to downgrade the MR2 module to a release lower than R05.2.00b.
- MR2-M and MR2-X modules cannot be mixed together in any MLXe chassis
- MR and MR2 modules cannot be mixed together in any MLXe chassis
- Do not downgrade the MBRIDGE version on the MR2 module.
 - The MR2 management module requires MBRIDGE version 36 or later for -4, -8, and -16 slot devices
 - The MR2 management module requires MBRIDGE32 version 35 or later for -32 slot devices
- In certain module combinations, you will need to make sure the supported software is loaded.

Interface modules

There are three generations of interface modules for Brocade MLXe routers.

[Table 3](#) lists the interface modules that are available for Brocade MLXe Series routers.

TABLE 3 Interface modules for all Brocade MLXe Series routers

SKU	Ports	Description	Generation
NI-MLX-10GX2	2	NetIron MLX Series 2-port 10-GbE module with IPv4/IPv6/MPLS hardware support - requires XFP optics	Gen 1
NI-XMR-10GX2	2	NetIron XMR Series 2-port 10-Gbps Ethernet module - requires XFP optics. IPv4, IPv6, MPLS support	Gen 1
BR-MLX-100GX-1	1	MLXE/XMR/MLX 1-port 100-GbE (X) Module with IPv4/IPv6/MPLS hardware support - requires CFP optics. Supports 1M IPv4 routes in FIB in XMR mode and 512K IPv4 routes in MLX mode. Requires high speed switch fabric modules. License upgradable to 2-ports on a MLXe.	Gen 2
BR-MLX-100GX-2	2	MLXE 2-port 100-GbE (X) Module with IPv4/IPv6/MPLS hardware support - requires CFP optics. Supports 1M IPv4 routes in FIB in XMR mode and 512K IPv4 routes in MLX mode. Requires high speed switch fabric modules.	Gen 2
NI-MLX-10GX4	4	NetIron MLX Series 4-port 10-GbE module with IPv4/IPv6/MPLS hardware support - requires XFP optics	Gen 1.1
NI-XMR-10GX4	4	NetIron XMR Series 4-port 10-GbE module with IPv4/IPv6/MPLS hardware support - requires XFP optics	Gen 1.1
BR-MLX-10GX4-X	4	XMR/MLXe 4-port 10-GbE (X) module with IPv4/IPv6/MPLS hardware support - requires XFP optics. Supports 1M IPv4 routes in FIB.	Gen 1.1
BR-MLX-10Gx4-X-ML	4	MLX/MLXe 4-port 10-GbE (ML) module with IPv4/IPv6/MPLS hardware support-requires XFP optics. Supports 512K IPv4 routes in FIB. License Upgradable to "X" scalability (1M IPv4 routes in FIB).	Gen 1.1
NI-MLX-10GX8-M	8	Brocade MLX Series 8-port 10-GbE (M) module with IPv4/IPv6/MPLS hardware support - requires SFPP optics. Supports 512K IPv4 routes in FIB. Requires high speed switch fabric modules	Gen 2
NI-MLX-10GX8-D	8	Brocade MLX Series 8-port 10-GbE (D) module with IPv4/IPv6 hardware support - requires SFPP optics. Supports 256K IPv4 routes in FIB. Doesn't support MPLS. Requires high speed switch fabric modules	Gen 2
BR-MLX-10GX8-X	8	MLXe/XMR 8-port 10-GbE (X) module with IPv4/IPv6/MPLS hardware support-requires SFPP optics. Supports 1M IPv4 routes in FIB. Requires high speed switch fabric modules.	Gen 2
NI-MLX-1GX20-SFP	20	NetIron MLX Series 20-port FE/GE (100/1000) module with IPv4/IPv6/MPLS hardware support - requires SFP optics. Note: Copper SFPs are supported at 1000Mbps only	Gen 1
NI-XMR-1GX20-SFP	20	NetIron XMR Series 20-port FE/GE (100/1000) module with IPv4/IPv6/MPLS hardware support - requires SFP optics. Note: Copper SFPs are supported at 1000Mbps only	Gen 1
NI-MLX-1GX20-GC	20	NetIron MLX Series 20-port 10/100/1000 copper module with IPv4/IPv6/MPLS hardware support	Gen 1

1 Router modules

TABLE 3 Interface modules for all Brocade MLXe Series routers (Continued)

SKU	Ports	Description	Generation
NI-XMR-1Gx20-GC	20	NetIron XMR Series 20-port 10/100/1000 copper module with IPv4/IPv6/MPLS hardware support	Gen 1
BR-MLX-1GCX24-X	24	XMR/MLXE 24-port 10/100/1000 Copper (RJ-45) Module with IPv4/IPv6/MPLS hardware support. Supports 1M IPv4 routes in FIB.	Gen 1.1
BR-MLX-1GCX24-X-ML	24	MLX/MLXE 24-port 10/100/1000 Copper (RJ-45) Module with IPv4/IPv6/MPLS hardware support. Supports 512K IPv4 routes in FIB. License Upgradable to "X" scalability (1M IPv4 routes in FIB).	Gen 1.1
BR-MLX-1GFX24-X	24	XMR/MLXE 24-port 1-GbE Fiber (SFP) Module with IPv4/IPv6/MPLS hardware support. Supports 1M IPv4 routes in FIB.	Gen 1.1
BR-MLX-1GFX24-X-ML	24	MLX/MLXE 24-port 1-GbE Fiber (SFP) Module with IPv4/IPv6/MPLS hardware support. Supports 512K IPv4 routes in FIB. License Upgradable to "X" scalability (1M IPv4 routes in FIB).	Gen 1.1
BR-MLX-10GX24-DM	24	MLXe 24-port 10-GbE Module with IPv4/IPv6/MPLS hardware support - requires SFPP optics. Bandwidth up to 200Gbps per module. Supports 256K IPv4 routes.	Gen 1.1
NI-MLX-1GX48-T-A	48	NetIron MLX Series 48-port 10/100/1000Base-T, MRJ21 module with IPv4/IPv6/MPLS hardware support. Requires high speed fans NIBI-16-FAN-EXH-A on MLX-16.	Gen 1.1

Depending on your router model, you can install up to 32 single-slot interface modules, or 16 double-slot interface modules.

Interface modules are hot-swappable, which means you can remove and replace them without powering down the system.

NOTE

For the latest and most up to date information on modules supported on MLXe chassis, log in to www.mybrocade.com and access the TECH NOTE: BROCADE MLX SERIES MODULE SUPPORT document.

NOTE

Specific information regarding RAD optics configuration on the Brocade MLXe Series platforms has been documented in the RAD optics Solutions test report. Please work with your account team to gain access to the document.

100xGbE 2-port interface module

The 100xGbE 2-port interface module is supported on all Brocade MLXe Series routers. This interface module has two 100 Gbps CFP optics ports, 2 Gbps memory, an internal flash of 32MB for local storage of CPU images, and 64MB for local storage of FPGA images. The 100xGbE 2-port interface module supports 1.5 GB buffering per port.

The 100xGbE interface module occupies two interface module slots in any chassis, with one slot active and one slot inactive. In all devices, the lower number of the two occupied slots becomes the active slot.

Before you install a 2x100GbE module, you will need to remove the center slot guide that divides the slot into two partitions. Do not discard this guide, as you will need it if you ever want to convert the slot into two slots. For information about how to remove the center guide and install high-speed fabric modules, refer to the 2x100GbE module installation instructions in the appropriate installation chapter for your router model.

NOTE

Before installing the 100GbE module in a chassis, the **tm-credit-size** must be changed to 1024 bytes.

You will also need to change the system **tm-credit-size** to 1024b (which readies the device to forward 100 Gbps traffic). Log into your system and enter the following commands in the configuration level of the CLI. Remember to write to memory and reload the device.

```
Brocade# config
Brocade(config)# system-init tm-credit-size credit_1024b
Brocade(config)# exit
Brocade# write memory
Brocade# reload
```

NOTE

The 100GbE module requires a minimum software version of R05.2.00. Please upgrade all software on the system to a minimum version of R05.2.00 before you install your 2x100G module.

NOTE

100xGbE modules require high-speed switch fabric modules to operate.

[Figure 7](#) shows the front panel of the 2x100GbE 2-port interface module.

FIGURE 7 100xGbE 2-port interface module front panel

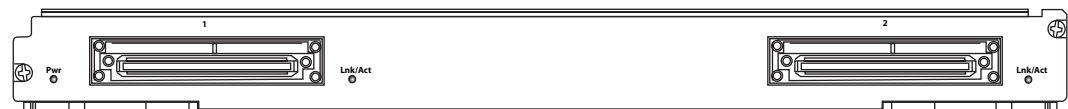

The front panel contains the following features:

- Power LED and Lnk/Act LED for each port (as described in [Table 4](#))
- Two 100xGbE CFP ports

100xGbE interface module LEDs

The LEDs on the 100xGbE interface modules indicate the status of each port, as described in [Table 4](#).

TABLE 4 100xGbE module LEDs

LED	Location	State	Meaning
Power (module state)	Left side of module	Green	Module is receiving power
		Off	Module is not receiving power
Lnk/Act	To the right of each port.	Green blinking	Port is enabled and link is up.
		Off	Port is disabled.

1 Router modules

CFP optics

The 100 GbE interface module is 802.3ba compliant, supports CFP-based optics, and can be used with existing Brocade MLXe interface modules. This interface module requires high-speed fabric modules. 100GbE interface modules will boot in turbo mode if all modules in the chassis are Gen-2 modules.

You must insert CFP-compliant fiber-optic transceivers in each port you intend to use. CFP-compliant transceivers provide an optical or physical medium-dependent (PMD) interface for single- or multi-mode fiber that can be used with either the LAN physical layer (PHY) or WAN physical layer (WAN PHY).

For a list of supported 100GbE CFP-compliant fiber-optic transceivers that are available from Brocade, refer to the latest version of the Brocade Optics Family Data Sheet, available online in the following location:

http://www.brocade.com/downloads/documents/data_sheets/product_data_sheets/Optics_DS.pdf

For more information about fiber-optic transceivers and associated cabling, refer to “[Installing a fiber-optic transceiver](#)” on page 146.

Power supply requirements for 100GbE modules

For power supply requirements for the 100GbE modules, refer to [Chapter 7, “Hardware Specifications”](#).

MLX 24-port 10Gbps (BR-MLX-10Gx24-DM) Interface Modules

Figure 8 shows the front panel of the BR-MLX-10Gx24-DM interface module.

The 24-port, 10 Gbps interface module (BR-MLX-10Gx24-DM) provides twenty four 10 Gbps ports that support SFP+ optics.

The BR-MLX-10Gx24-DM interface module supports 4.5 GB buffering per module.

BR-MLX-10Gx24-DM module is an oversubscribed module. The module can support up to 200Gbps when the system fabric mode is in Turbo mode (i.e. system has only Gen 2 and Gen 3 modules such as 8x10G, 100G or 24x10G modules). The module can support up to 12 10G wire-speed ports when the system fabric mode is in Normal mode (i.e. system also has any Gen 1 modules such as 1G or 4x10G modules).

FIGURE 8 BR-MLX-10Gx24-DM module front panel

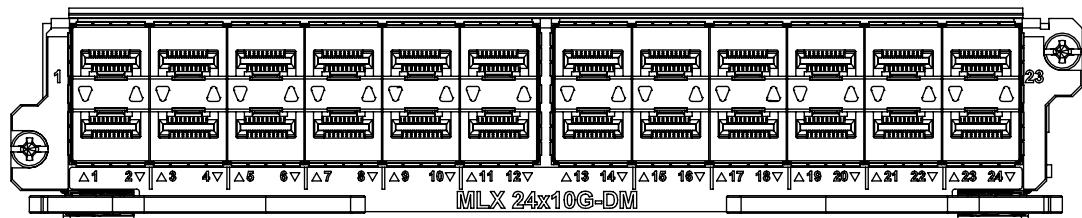

The front panel includes the following features:

- Arrow-shaped LEDs in center horizontal strip for all ports. LEDs to the left support the top ports, LEDs to the right (pointing down) support the bottom ports.
- Twenty four 10G Ethernet ports

Table 5 describes the LEDs for the BR-MLX-10Gx24-DM interface modules.

TABLE 5 BR-MLX-10Gx24-DM module LEDs

Position	State	Meaning
Arrow-shaped LEDs in center horizontal strip between ports. Left LEDs support upper ports. Right LEDs support lower ports.	Solid green	A link has been established.
	Green blinking	The port is transmitting and receiving packets.
	Off	No link exists, and the port is not transmitting or receiving packets.

1 Router modules

Power supply requirements for BR-MLX-10Gx24-DM modules

For power supply requirements for BR-MLX-10Gx24-DM interface modules, refer to [Chapter 7, “Hardware Specifications”](#).

8x10GE-X interface modules

The 8x10GE-X interface modules provide 8 ports of 10 Gigabit Ethernet with support for up to 1M IPv4 routes in hardware.

NOTE

Gen-2 8x10GE-X modules require high speed switch fabric modules to operate. You can replace switch fabric modules with high-speed switch fabric modules while the system is powered on and running. For more information about high-speed switch fabric modules, refer to “High-speed switch fabric modules” on page 31.

Figure 9 shows the faceplate of the 8x10GE-X module.

FIGURE 9 8x10GE-X module faceplate

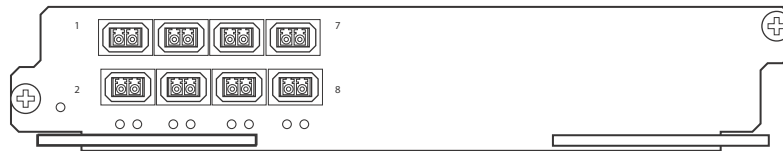

8x10GE-X modules support SFP+ optics only; they do not support SFP or XFP optics. For a list of supported SFP+ optics, refer to the latest version of the Brocade Optics Family Data Sheet, available online in the following location:

http://www.brocade.com/downloads/documents/data_sheets/product_data_sheets/Optics_DS.pdf

8x10GE-X interface module LEDs

The 8x10GE-X interface module LEDs indicate module and port status, as described in Table 6.

TABLE 6 8x10GE-X module LEDs

LED	Location	State	Meaning
Power	Lower left corner of module	Green	Module is receiving power
		Off	Module is not receiving power
Link/Act	Below the ports. Top port LED on left, bottom port LED on right.	Green blinking	Port enabled and link is passing traffic. LED is solid green when link is idle.
		Off	Port is disabled.

Power supply requirements for 8x10GE-X modules

For power supply requirements for the 8x10GE-X modules, refer to [Chapter 7, “Hardware Specifications”](#).

Gen-1 10Gx2 and 10Gx4 Ethernet interface modules

Gen-1 2-port and 4-port 10 Gbps Ethernet interface modules are available in the following formats:

- NI-MLX-10Gx2 - 2-port interface module for MLX devices
- NI-XMR-10Gx2 - 2-port interface module for XMR devices
- NI-MLX-10Gx4 - 4-port interface module for MLX devices
- NI-XMR-10Gx4 - 4-port interface module for XMR devices

NOTE

When you install Gen-1 2-port or 4-port 10 Gbps Ethernet interface modules, you must upgrade the software on all interface modules and management modules to the appropriate software release. For more information on the appropriate software release refer to the Hardware Installation Notes that shipped with the interface module.

Figure 10 shows Gen-1 2-port and 4-port 10 Gbps Ethernet interface module front panels.

FIGURE 10 Gen-1 2-port and 4-port 10 Gbps Ethernet module front panels

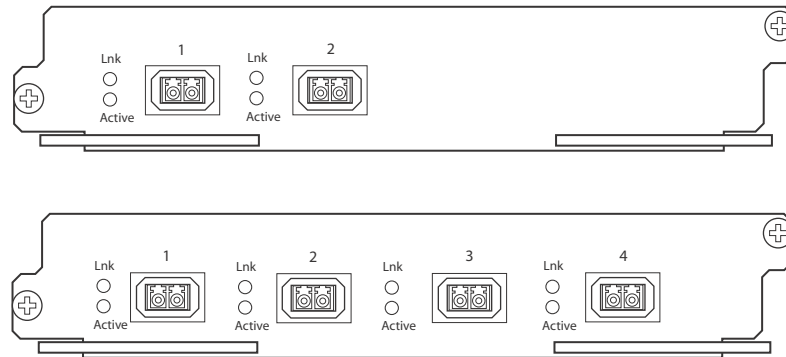

The front panel of the 2-port module includes the following features:

- Two LEDs per port (as described in [Table 7](#))
- Two 10 Gbps Ethernet XFP optics ports

The front panel of the 4-port module includes the following features:

- Two LEDs per port (as described in [Table 7](#))
- Four 10 Gbps Ethernet XFP optics ports

10 Gbps Ethernet interface module LEDs

Gen-1 2-port and 4-port interface modules have LEDs that indicate the status of each port, as described in [Table 7](#).

TABLE 7 Gen-1 2-port or 4-port 10 Gbps Ethernet module LEDs

LED	Location	State	Meaning
Link	Left of each Ethernet port	On	A link is established with the remote port.
		Off	A link is not established with the remote port.
Active	Left of each Ethernet port	On	The port is transmitting and receiving packets.
		Off	The port is not transmitting or receiving packets.

10 Gbps Ethernet ports

The Gen-1 2-port or 4-port Ethernet modules (BR-MLX-10Gx4-X) have either two or four physical ports that allow you to connect your router to other network routers at a speed of 10 Gbps.

You must insert XFP-compliant fiber-optic transceivers in each port you intend to use. XFP-compliant transceivers provide an optical or physical medium-dependent (PMD) interface for single- or multi-mode fiber that can be used with either the LAN physical layer (PHY) or WAN physical layer (WAN PHY).

For a list of XFP-compliant fiber-optic transceivers supported for Gen-1 2-port or 4-port modules, refer to the latest version of the Brocade Optics Family Data Sheet, available online in the following location:

http://www.brocade.com/downloads/documents/data_sheets/product_data_sheets/Optics_DS.pdf

For more information about fiber-optic transceivers and associated cabling, refer to “Installing a fiber-optic transceiver” on page 146.

Power supply requirements for Gen-1 2-port or 4-port 10 Gbps Ethernet interface modules

For power supply requirements for Gen-1, 2-port or 4-port 10 Gbps Ethernet interface modules, refer to [Chapter 7, “Hardware Specifications”](#).

Gen-1.1 4-port 10 Gbps Ethernet interface modules

Gen-1.1 4-port 10 Gbps Ethernet interface modules are available in the following formats:

- BR-MLX-10Gx4-X-ML - 4-port interface module
- BR-MLX-10Gx4-X - 4-port interface module licensed for 1 million routes

NOTE

The 10Gx4-X10 GbE module requires a minimum software version of R05.1.00. Please upgrade all software on the system to a minimum of R05.1.00 before installing your 10Gx4-X module.

[Figure 11](#) shows the front panel of 4-port 10 Gbps Ethernet interface modules.

FIGURE 11 BR-MLX-10Gx4-X and BR-MLX-10Gx4-X-ML interface module front panel

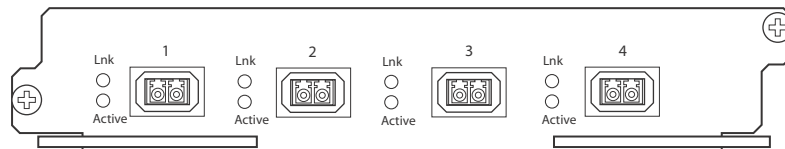

The front panel of the BR-MLX-10GX4-X and BR-MLX-10Gx4-X-ML modules includes the following features:

- Two LEDs per port
- Four 10 Gbps Ethernet XFP optics ports

BR-MLX-10GX4-X and BR-MLX-10Gx4-X-ML interface module LEDs

The BR-MLX-10GX4-X and BR-MLX-10Gx4-X-ML interface module LEDs indicate the status of each port, as described in [Table 8](#).

TABLE 8 BR-MLX-10GX4-X and BR-MLX-10Gx4-X-ML Ethernet module LEDs

LED	Location	State	Meaning
Link	Left of each Ethernet port	On	A link is established with the remote port.
		Off	A link is not established with the remote port.
Active	Left of each Ethernet port	On	The port is transmitting and receiving packets.
		Off	The port is not transmitting or receiving packets.

BR-MLX-10GX4-X and BR-MLX-10Gx4-X-ML interface module Ethernet ports

The BR-MLX-10GX4-X interface module has four physical ports that allow you to connect your router to other network routers at a speed of 10 Gbps. BR-MLX-10Gx4-X-ML supports up to 512K IPv4 routes in hardware. BR-MLX-10Gx4-X supports up to 1M IPv4 routes. BR-MLX-10Gx4-X-ML can be upgraded to an X version through a software license. Please contact Brocade to purchase the license upgrade.

You must insert XFP-compliant fiber-optic transceivers in each port you intend to use. XFP-compliant transceivers provide an optical or physical medium-dependent (PMD) interface for single- or multi-mode fiber that can be used with either the LAN physical layer (PHY) or WAN physical layer (WAN PHY).

For an up to date list of the 10 Gbps XFP-compliant fiber-optic transceivers that are available from Brocade, refer to the latest version of the Brocade Optics Family Data Sheet, available online in the following location:

http://www.brocade.com/downloads/documents/data_sheets/product_data_sheets/Optics_DS.pdf

For more information about fiber-optic transceivers and associated cabling, refer to “[Installing a fiber-optic transceiver](#)” on page 146.

Power supply requirements for 10Gx4 interface modules

For power supply requirements for the 10Gx4 modules, refer to [Chapter 7, “Hardware Specifications”](#).

8-port 10 Gbps M and D interface modules

For Brocade MLXe routers, the 8-port, 10 Gbps interface modules (NI-MLX-10Gx8-M and NI-MLX-10Gx8-D) provide eight 10 Gbps ports that support SFP+ optics. These modules contain an internal flash memory of 16 MB for local storage of CPU images, and 32 MB for local storage of FPGA images. The NI-MLX-10Gx8-M interface module supports a buffer of 3 GB buffering per module. The NI-MLX-10Gx8-D module supports 1 GB buffering per module.

NOTE

When installing NI-MLX-10Gx8-M or NI-MLX-10Gx8-D modules, you must first upgrade the software on all interface modules and management modules to Multi-Service IronWare software R05.0.00 or later. For more information, refer to the Hardware Installation Notes that shipped with the modules.

NOTE

NI-MLX-10Gx8-D interface modules do not support MPLS.

NOTE

NI-MLX-10Gx8-M or NI-MLX-10Gx8-D modules require high-speed switch fabric modules to operate. You can replace switch fabric modules with high-speed switch fabric modules while the system is powered on and running. For more information about high-speed switch fabric modules, see “High-speed switch fabric modules” on page 31.

Figure 12 displays the faceplate of the NI-MLX-10Gx8-M and NI-MLX-10Gx8-D modules. Figure 13 shows the RX and TX orientation for the ports, and identifies which LED goes with which port.

FIGURE 12 NI-MLX-10Gx8-M and NI-MLX-10Gx8-D module faceplate

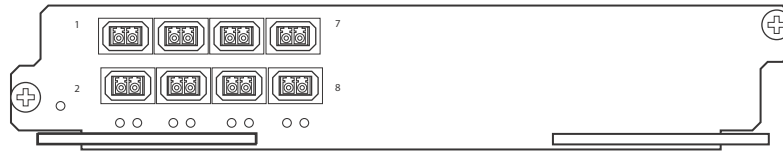
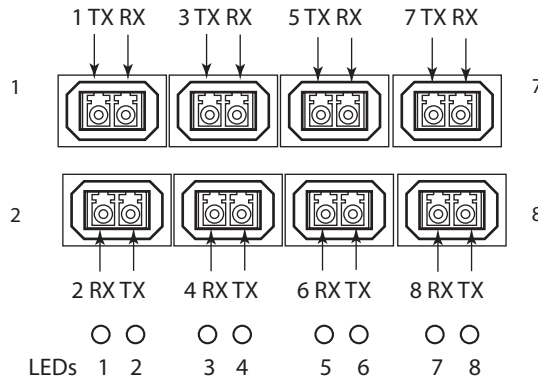

FIGURE 13 Port RX and TX, and LED designations for NI-MLX-10Gx8-M and NI-MLX-10Gx8-D modules



NI-MLX-10Gx8-M and NI-MLX-10Gx8-D modules support the SFP+ optics; they do not support SFP optics. For a list of supported SFP+ optics, refer to the latest version of the Brocade Optics Family Data Sheet, available online in the following location:

http://www.brocade.com/downloads/documents/data_sheets/product_data_sheets/Optics_DS.pdf

NI-MLX-10Gx8-M and NI-MLX-10Gx8-D interface module LEDs

The NI-MLX-10Gx8-M and NI-MLX-10Gx8-D interface module LEDs indicate module and port status, as described in Table 9.

TABLE 9 NI-MLX-10Gx8-M and NI-MLX-10Gx8-D interface module LEDs

LED	Location	State	Meaning
Power	Lower left corner of module	Green	Module is receiving power
		Off	Module is not receiving power
Link/Activity	Underneath the ports. Top port LED on left, bottom port LED on right.	Green blinking	Port enabled and link is up.
		Off	Port is disabled.

Installation considerations

When you install NI-MLX-10Gx8-M or NI-MLX-10Gx8-D modules, you must upgrade the software on all interface modules and management modules to the appropriate software release. Refer to the Hardware Installation Notes that shipped with the interface module.

NOTE

NI-MLX-10Gx8-D modules do not support Multiprotocol Label Switching (MPLS).

If you try to configure MPLS on a device that has NI MLX 8x10G -D modules installed, you will see the following error message.

```
Brocade(config)# router mpls
The command can't be used when system contains -d class modules.
```

If you install an NI-MLX-10Gx8-D module in a device that is running MPLS, the NI-MLX-10Gx8-D module boots in INTERACTIVE mode, and the following error message is displayed.

```
Brocade#
Module is inserted into slot 7
SYSLOG: May 28 16:22:35:<13>May 28 16:22:35 System: Module was inserted to slot 7
Module 7 is -d class, it can't work when router mpls is enabled.
Reset slot 7
```

```
SYSLOG: May 28 16:22:48 :<13>May 28 16:22:48 Module 7 is reset by mgmt (reason:
boot to interactive mode)
```

Power supply requirements for NI-MLX-10Gx8-M and NI-MLX-10Gx8-D modules

For power supply requirements for NI-MLX-10Gx8-M and NI-MLX-10Gx8-D modules, refer to [Chapter 7, “Hardware Specifications”](#).

24-port 1 Gbps Ethernet copper RJ45 interface module

The 24-port 1 Gbps Ethernet copper interface module is available in the following formats:

- BR-MLX-1GCx24-X-ML
- BR-MLX-1GCx24-X

This module has 32 Mb of flash memory and contains 24 RJ45 physical ports, through which you can connect your router to other network routers. BR-MLX-1GCx24-X-ML supports up to 512K IPv4 routes in hardware and BR-MLX-1GCx24-X version supports up to 1M IPv4 routes in hardware. BR-MLX-1GCx24-X-ML does not include a software license, but can be upgraded to an X version through a software license. Please contact Brocade to purchase the license upgrade.

NOTE

When you install BR-MLX-1GCx24-X modules, you must upgrade the software on all interface modules and management modules to the appropriate software release. For more information on the appropriate software release refer to the Hardware Installation Notes that shipped with the modules.

NOTE

When you are replacing older modules with 24x1G modules, you must first delete the software configuration for the older module. If you do not delete the old configuration, a configuration mismatch will occur when you install the new module. This mismatch will be displayed in the results of the **show config** command.

NOTE

The SNMP Management Information Base (MIB) uses the Interface Index (ifIndex) to assign a unique value to each port on a module or slot. The number of indexes that can be assigned per module is 20, 40, or 64, depending on the number of ports on the module. When installing 24-port copper or fiber interface modules, you must change the ifIndex allocation to 64 before you install the module, or the module will not operate properly.

Figure 14 shows the front panel of the BR-MLX-1GCx24-X interface module.

FIGURE 14 BR-MLX-1GCx24-X copper interface module front panel

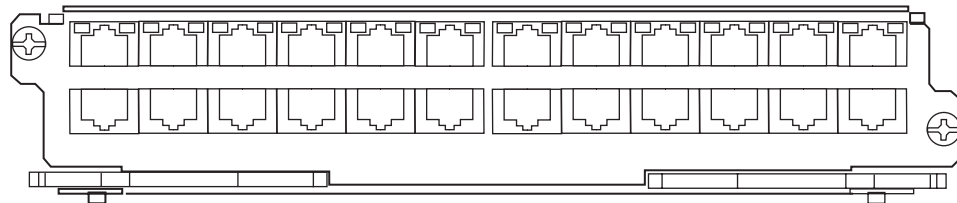

The front panel includes the following features:

- LEDs to the left support the top ports, LEDs to the right support the bottom ports
- 24 1 Gbps RJ45 copper ports

Table 10 describes the LEDs for the BR-MLX-1GCx24-X interface module.

TABLE 10 BR-MLX-1GCx24-X copper module LEDs

Position	State	Meaning
LEDs located at top right and left edge of top row ports. Left LED for top port, right LED for bottom port)	Solid green	A link has been established.
	Green blinking	The port is transmitting and receiving packets.
	Off	No link exists and the port is not transmitting or receiving packets.

Power supply requirements for BR-MLX-1GCx24-X interface modules

For power supply requirements for BR-MLX-1GCx24-X interface modules, refer to [Chapter 7, “Hardware Specifications”](#).

24-port 1 Gbps fiber interface module

The 24-port 1 Gbps fiber interface module is available in the following formats:

- BR-MLX-1GFx24-X
- BR-MLX-1GFx24-X-ML

The 24-port 1 Gbps fiber interface modules has 32 Mb of flash memory and provide 24 physical ports, through which you can connect your router to other network routers. BR-MLX-1GFx24-X-ML supports up to 512K IPv4 routes in hardware. BR-MLX-1GFx24-X supports up to 1M IPv4 routes in hardware. The ML version can be upgraded to a X version through a software license. Please contact Brocade to purchase the license upgrade.

NOTE

24-port 1 Gbps fiber interface modules support 1 Gbps Copper SFP optics at 10 Mbps, 100Mbps and 1Gbps speeds.

NOTE

When you install BR-MLX-1GFx24-X and BR-MLX-1GFx24-X-ML modules, you must upgrade the software on all interface modules and management modules to the appropriate software release. For more information on the appropriate software release refer to the Hardware Installation Notes that shipped with the modules.

NOTE

When you are replacing older modules with 24x1G modules, you must first delete the software configuration for the older module. If you do not delete the old configuration, a configuration mismatch will occur when you install the new module. This mismatch will be displayed in the results of the **show config** command.

NOTE

The SNMP Management Information Base (MIB) uses the Interface Index (ifIndex) to assign a unique value to each port on a module or slot. The number of indexes that can be assigned per module is 20, 40, or 64, depending on the number of ports on the module. When installing 24-port copper or fiber interface modules, you must change the ifIndex allocation to 64 before you install the module, or the module will not operate properly when installed.

Figure 15 shows the front panel of the BR-MLX-1GFx24-X and BR-MLX-1GFx24-X-ML fiber interface modules.

FIGURE 15 BR-MLX-1GFx24-X and BR-MLX-1GFx24-X-ML fiber interface module front panel

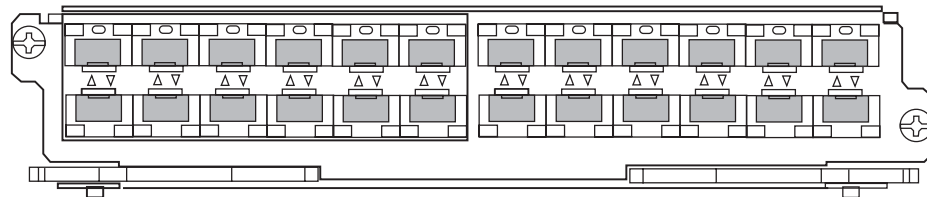

The front panel includes the following features:

- Arrow-shaped LEDs in center horizontal strip for all ports. LEDs to the left support the top ports, LEDs to the right (pointing down) support the bottom ports.
- 24 1 Gbps fiber ports

Table 11 describes the LEDs for the BR-MLX-1GFx24-X and BR-MLX-1GFx24-X interface modules.

TABLE 11 BR-MLX-1GFx24-X and BR-MLX-1GFx24-X fiber module LEDs

Position	State	Meaning
Arrow-shaped LEDs in center horizontal strip between ports. Left LEDs support upper ports. Right LEDs support lower ports.	Solid green	A link has been established.
	Green blinking	The port is transmitting and receiving packets.
	Off	No link exists, and the port is not transmitting or receiving packets.

1 Router modules

For a list of SFP optics supported for the BR-MLX-1GFx24-X and [BR-MLX-1GFx24-X](#) interface modules, refer to the latest version of the Brocade Optics Family Data Sheet, available online in the following location:

http://www.brocade.com/downloads/documents/data_sheets/product_data_sheets/Optics_DS.pdf

Power supply requirements for BR-MLX-1GFx24-X and BR-MLX-1GFx24-X-ML interface modules

For power supply requirements for BR-MLX-1GFx24 and BR-MLX-1GFx24-X ML (24-port 1 Gbps) fiber interface modules, refer to [Chapter 7, “Hardware Specifications”](#).

20-port 100/1000 Ethernet interface module

[Figure 16](#) shows the front panel of the 20-port 100/1000 Gbps Ethernet SFP interface module.

FIGURE 16 20-port 100/1000 Ethernet module front panel

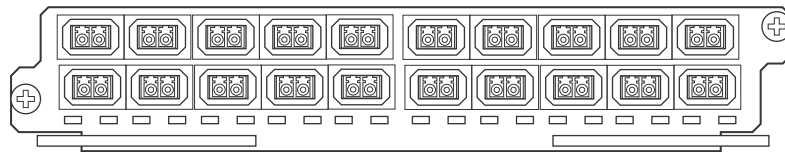

The front panel includes the following features:

- LEDs to the left support the top ports, LEDs to the right support the bottom ports
- 20 100/1000 Ethernet SFP ports

[Table 12](#) describes the LEDs for the 20-port 100/1000 Ethernet module

TABLE 12 20-port 100/1000 Ethernet module LEDs

Position	State	Meaning
Below each Ethernet port. (Left-side LED supports port in top row. Right-side LED supports port in bottom row.)	On or blinking	The port is transmitting and receiving packets.
	Off for an extended period	The port is not transmitting or receiving packets.

100/1000 Ethernet ports

The 100/1000 Ethernet interface module contains 20 physical ports, through which you can connect your router to other network routers at a speed of 100 Mbps or 1 Gbps.

You must insert an SFP-compliant fiber-optic transceiver (provided by Brocade) into a physical port. SFP-compliant fiber-optic transceivers provide a physical medium-dependent (PMD) fiber interface that can be used with either the LAN physical layer (PHY) or WAN physical layer (WAN PHY).

For a list of SFP optics supported by Brocade, refer to the latest version of the Brocade Optics Family Data Sheet, available online in the following location:

http://www.brocade.com/downloads/documents/data_sheets/product_data_sheets/Optics_DS.pdf

20-port 10/100/1000 Ethernet interface module

Figure 17 shows the front panel of the 20-port 10/100/1000 Ethernet RJ45 module.

FIGURE 17 20-port 10/100/1000 copper Ethernet interface module front panel

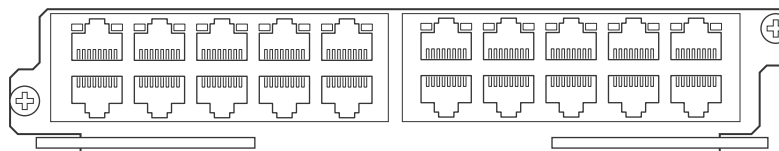

The front panel includes the following features:

- LEDs
- Twenty 10/100/1000 copper Ethernet ports.

Table 13 describes the 20-port 10/100/1000 Ethernet module LEDs.

TABLE 13 20-port 10/100/1000 Ethernet module LEDs

LED	Position	State	Meaning
Link or Active	Above the ports. The top port LED is on the left side, the bottom port LED is on the right side.	On (solid)	A link is established with the remote port (with no traffic).
		Blinking	The port is transmitting and receiving packets.
		Off	A link is not established with the remote port and no traffic is being passed.

NI-MLX-1Gx48-T-A interface module

Figure 18 shows the front panel of the NI-MLX-1Gx48-T-A interface module.

FIGURE 18 NI-MLX-1Gx48-T-A module front panel

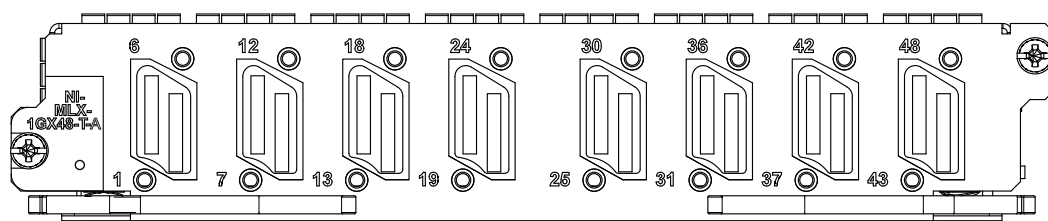

The front panel includes the following features:

- A power LED located below the part number
- Eight mini-RJ21 connectors, each supporting six 10/100/1000 Mbps Ethernet ports

The eight mini-RJ21 connectors support six 1 Gbps Ethernet ports each. You can connect a patch panel with a mini-RJ21 connector to a mini-RJ21 connector on the interface module. The patch panel provides RJ45 connectors. You can also use a cable with a mini-RJ21 connector on one end that connects to the mini-RJ21 connector on the interface module. The other end of the cable splits into six cables with RJ45 connectors on each cable.

The NI-MLX-1Gx48-T-A module ships with two cable cinches. Each cable cinch consists of a plastic part and a velcro strap. For instructions on using the cable cinches, see [Chapter 3, "Using Brocade Structured Cabling Components"](#).

1 Router modules

Cables and patch panels that support this module are available through any Tyco International distribution partner. Information about these products is available at the following URL.

www.brocade.com

NOTE

Before you install NI-MLX-1Gx48-T-A modules, you must first upgrade the software on all interface modules and management modules to the appropriate software release. For more information refer to the Hardware Installation Notes that shipped with the modules.

Power supply requirements for NI-MLX-1Gx48-T-A modules

For power supply requirements for NI-MLX-1Gx48-T-A interface modules, refer to [Chapter 7](#), “Hardware Specifications”.

NOTE

When one or more NI-MLX-1Gx48-T-A modules are installed in an MLX16-slot router, you must replace the NI-X-16-FAN-EXH modules with NIBI-16-FAN-EXH-A high-speed fan modules. For more information about high-speed fan modules, see “[NIBI-16-FAN-EXH-A high-speed fan assemblies](#)” on page 38. If the 16-slot router is not upgraded to support NIBI-16-FAN-EXH-A modules before NI-MLX-1Gx48-T-A modules are installed, the following Syslog message is displayed.

```
SYSLOG: Mar 26 14:19:53:<12>R1, 48X1G modules in slots 10,11,13,16 shouldn't be running without high speed fans.
```

NOTE

The NIBI-16-FAN-EXH-A fan module does not ship with some Brocade MLXe-16 routers. Contact Brocade to purchase this module.

To display information about NIBI-16-FAN-EXH-A modules installed in a 16-slot router, enter the **show chassis** command.

```
Brocade# show chassis
*** Brocade MLX-16 chassis ***
Power 1 (H1250CFN - AC 1200W): Installed (OK)
Power 2: Installed (Failed or Disconnected)
Power 3: not present
Power 4: Installed (Failed or Disconnected)
Power 5: (H1250CFN - AC 1200W): Installed (OK)
Power 6: (30351200 - AC 1200W): Installed (OK)
Power 7: Installed (Failed or Disconnected)
Power 8: (30351200 - AC 1200W): Installed (OK)
Total power budget for chassis = 4800 W
Total power used by system core = 762 W
Total power used by LPs = 1040 W
Total power available = 2998 W
Slot Power-On Priority and Power Usage:
Slot10 pri=1 module type=NI-MLX-1Gx48-T-A 48-port 10/100/1000Base-T MRJ21
Module power usage=260W
Slot11 pri=1 module type=NI-MLX-1Gx48-T-A 48-port 10/100/1000Base-T MRJ21
Module power usage=260W
Slot13 pri=1 module type=NI-MLX-1Gx48-T-A 48-port 10/100/1000Base-T MRJ21
Module power usage=260W
Slot16 pri=1 module type=NI-MLX-1Gx48-T-A 48-port 10/100/1000Base-T MRJ21
Module power usage=260W
--- FANS ----
Bottom fan tray (fan 1): Status = OK, Speed = LOW (50%)
Bottom fan tray (fan 2): Status = OK, Speed = LOW (50%)
```

```
Bottom fan tray (fan 3): Status = OK, Speed = LOW (50%)
Bottom fan tray (fan 4): Status = OK, Speed = LOW (50%)
Bottom fan tray (fan 5): Status = OK, Speed = LOW (50%)
Bottom fan tray (fan 6): Status = OK, Speed = LOW (50%)
Rev A Back Fan A (revision 0x09): Status = OK, Speed = LOW (50%)
Rev A Back Fan B (revision 0x0c): Status = OK, Speed = LOW (50%)
```

The output displays firmware Revision A (Rev A) for NIBI-16-FAN-EXH-A modules. Rev A indicates that the router contains the required rear fan modules to support the NI-MLX-1Gx48-T-A modules. The RPM value thresholds (LOW/MED/MED-HI/HI) are also displayed for rear fan modules.

If the router does not contain NIBI-16-FAN-EXH-A modules, the **show chassis** command will not display Rev A for rear fan modules.

Forward Error Correction (FEC) mode

Using Forward Error Correction (FEC) mode enabled modules on a Brocade MLXe series chassis will reduce packet drops due to CRC errors. FEC will automatically be enabled on supported line cards and fabric links in a Brocade MLXe series chassis.

Forward Error Correction (FEC) mode is applicable for the Brocade MLXe series platforms. It will be operational only on the 32Ke chassis for the following cards:

- 2x100G
- 24x10G
- hSFMs (FE600 based SFMs)

FEC mode is applied on a per link basis. Both sides of the link (TM side and FE side) must be in the same mode. In a Brocade MLXe series chassis, the following applies:

- All fabric facing links on the 2x100 and 24x10 TMs will have FEC enabled
- hSFM links connected to 2x100 and 24x10 will have FEC enabled

Switch fabric modules

Table 14 lists all switch fabric modules that are available for Brocade MLXe routers. For a detailed compatibility matrix of which fabric modules can be used with which router configurations, refer to the relevant *Release Notes*.

TABLE 14 Switch fabric modules available for Brocade MLXe routers

Part number	Description
NI-X-SF1	Switch fabric module for 4-slot routers
NI-X-SF3	Switch fabric module for 8- and 16-slot routers
NI-X-32-SF	Switch fabric module for 32-slot routers
NI-X-4-HSF	High speed switch fabric module for 4-slot routers
NI-X-16-8-HSF	High speed switch fabric module for 8- and 16-slot routers
NI-X-32-HSF	High speed switch fabric module for 32-slot routers

Table 15 lists all switch fabric modules that are available for Brocade MLXe routers. For a detailed compatibility matrix of which fabric modules can be used with which router configurations, refer to the relevant *Release Notes*.

TABLE 15 Switch fabric modules available for Brocade MLXe routers

Part number	Description
NI-X-4-HSF	High speed switch fabric module for 4-slot routers
NI-X-16-8-HSF	High speed switch fabric module for 8- and 16-slot routers
NI-X-32-HSF	High speed switch fabric module for 32-slot routers

Switch fabric modules switch packets from one interface module to another. Brocade MLXe routers can be configured with multiple switch fabric modules as described:

- 4-slot router: Accommodates three switch fabric modules (two required and one redundant) for a fully-loaded system. Ships with two switch fabric modules. You must purchase an additional switch fabric module to equip your router for redundancy.
- 8-slot router: Accommodates three switch fabric modules (two required and one redundant) for a fully-loaded system. Ships with two switch fabric modules. You must purchase an additional switch fabric module to equip your router for redundancy.
- 16-slot router: Accommodates four switch fabric modules (three required and one redundant) for a fully-loaded system. Ships with three switch fabric modules. You must purchase an additional switch fabric module to equip your router for redundancy.
- 32-slot router: Accommodates eight switch fabric modules. Brocade MLXe routers ship with seven fabric modules. You must purchase an additional switch fabric module to equip your MLXe router for redundancy.

NOTE

Brocade MLXe Series router switch fabric modules are dedicated, which means that they function properly in these routers only. If you attempt to install a Brocade MLXe Series router switch fabric module in another Brocade device or a switch fabric module intended for another Brocade device in a Brocade MLXe Series router, the router and switch fabric module will not function properly.

Figure 19 shows the front panel of a switch fabric module.

FIGURE 19 Switch fabric module front panel

The front panel contains two LEDs, as described in [Table 16](#).

TABLE 16 Switch fabric module LEDs

LED	Position	State	Meaning
Pwr	Above Active LED	On	The module is receiving power.
		Off	The module is not receiving power.
Active	Below Pwr LED	On (4-, 8-, and 16-slot routers only)	The switch fabric is on (active) and ready to switch user packets.
		Blinking (32-slot routers only)	The switch fabric is on (active) and being accessed by the Management Module CPU. This indicates normal operation.
		Off for extended period	The switch fabric is not active and cannot switch user packets.

High-speed switch fabric modules

NOTE

Gen-1 switch fabric modules and Gen-2 high-speed fabric (HSF) modules are not compatible and will not operate together in the same device.

HSF modules are supported on Brocade MLXe Series routers, and are interoperable with all existing interface modules.

HSF modules are hot-swappable, which means you can install or replace them while the system is powered up and running.

NOTE

Hot-swapping or installing high-speed switch fabric modules one-at-a-time may affect the performance of 2x100GbE interface modules. If you have 2x100GbE modules in your device, it is recommended that you bring your system down and install all required high-speed switch fabric modules before you bring the system back up.

NOTE

Do not remove or power-off all switch fabric modules on MLXe chassis while the device is up and running. Removing all the switch fabric modules from the device and then re-inserting them can cause the device to become unstable, resulting in protocol flaps and thereby traffic impact. A system reload is required to recover.

HSF modules can operate in normal mode or turbo mode but will boot in turbo mode only if all active interface modules are Gen-2 and Gen-3 modules.

Power supplies

Brocade supports the following power supply types:

- 1200W AC or DC power supply
- 1800W AC or DC power supply
- 2100W AC or DC power supply
- 2400W AC or DC power supply
- 3000W AC or DC power supply

Table 17 lists the power supplies that are available for Brocade MLXe routers.

TABLE 17 Power supplies

Part number	Description
BR-MLXE-ACPWR-1800	16-, 8- and 4-slot MLXe and 16- and 8-Slot XMR/MLX AC 1800W power supply.
BR-MLXE-DCPWR-1800	16-, 8- and 4-slot MLXe and 16- and 8-Slot XMR/MLX DC 1800W power supply.
NI-X-ACPWR	16-, 8- and 4-slot MLXe and 16- and 8-Slot XMR/MLX AC 1200W power supply.
NI-X-DCPWR	16-, 8- and 4-slot MLXe and 16- and 8-Slot XMR/MLX DC 1200W power supply.
NI-X-ACPWR-A	4-Slot NetIron XMR/MLX AC 1200W power supply.
NI-X-DCPWR-A	4-Slot NetIron XMR/MLX DC 1200W power supply.
BR-MLXE-32-ACPWR-3000	32-slot NetIron MLXe/XMR/MLX AC 3000W power supply.
BR-MLXE-32-DCPWR-3000	32-slot NetIron MLXe/XMR/MLX DC 3000W power supply.
NIBI-32-ACPWR-A	32-Slot NetIron MLXe/XMR/MLX AC 2400W power supply.
NIBI-32-DCPWR	32-Slot NetIron MLXe/XMR/MLX DC 2400W power supply.

Brocade MLXe Series routers support the following power supply options:

- 4-slot router: Can accommodate four 1200W or 1800W power supplies. For power redundancy, you must purchase additional power supplies depending on how you populate your router. For determining the number of power supplies required for redundancy, refer to Chapter 7, “Hardware Specifications”.
- 8-slot router: Can accommodate up to four 1200W or 1800W AC and DC power supplies. Because power is supplied over a common power bus, any power supply installed in addition to the minimum required provides backup for any supply that fails. For power redundancy, you must purchase additional power supplies depending on how you populate your router. For determining the number of power supplies required for redundancy, refer to Chapter 7, “Hardware Specifications”.
- 16-slot router: Can accommodate eight 1200W or 1800W AC and DC power supplies. Because power is supplied over a common power bus, any power supply installed in addition to the minimum required provides backup for any power supply that fails. For power redundancy, you must purchase additional power supplies depending on how you populate your router. For determining the number of power supplies required for redundancy, refer to Chapter 7, “Hardware Specifications”.

NOTE

1800W AC power supplies support low and high line operation. For line voltages between 90 - 180, the power supply operates at 1200W. For line voltages between 180 - 264, the power supply operates at 1800W.

- 32-slot router: Supports 2100W AC, 2400W AC and DC, and 3000W AC and DC models. Accommodates eight power supplies. Because power is supplied over a common power bus, any power supply installed in addition to the minimum required provides backup for any power supply that fails. For power redundancy, you must purchase additional power supplies depending on how you populate your router. For determining the number of power supplies required for redundancy, refer to Chapter 7, “Hardware Specifications”.

Power supply interoperability

For Brocade MLXe routers, power supplies for the 4-slot, 8-slot, and 16-slot devices are interchangeable. Power supplies for the Brocade MLXe 32-slot devices cannot be used in Brocade MLXe 4-slot, 8-slot, or 16-slot devices.

For power supply specifications, refer to “[Power specifications](#)” on page 215.

Power supplies are installed in slots along the bottom of 8-slot, 16-slot, and 32-slot routers. Power supplies are installed in slots in the rear of 4-slot routers.

Power supplies provide power to all router components, share the workload equally, and report status to the management module. If the management module detects that a power supply has failed or overheated, the management module redistributes the workload of the failed power supply to the remaining power supplies.

Power supplies generally have three LEDs on the faceplate that provide status for input power, output power, and notification of alarms. If the input power and output power LEDs are on (steady green), the power supply is providing power to the router components. For more information about power supply LEDs, refer to the AC and DC power supply sections in [Table 33](#) on page 229.

NOTE

After a power supply is removed from a router, the software determines if there is enough power to operate all of the interface modules. If there is not enough power, some interface modules will be powered off.

NOTE

If you want to perform a hitless upgrade, replace one power supply unit at a time, and make sure the device has at least +1 redundancy at all times.



DANGER

Power supplies are hot-swappable, which means they can be removed and replaced while the router is powered on and running. However, Brocade recommends that you disconnect a power supply from the power source before removing and replacing the supply. The 4-, 8-, and 16-slot router can be running while a power supply is being removed and replaced, but the power supply itself should not be connected to a power source. Otherwise, you could be injured, or the power supply or other parts of the router could be damaged. (In the 32-slot router, you cannot unlatch and remove a power supply without first releasing the cord retainer and removing the power cord.)

Rack mounting brackets

All routers ship with pre-installed mounting brackets that allow you to front-mount the router in a standard 19-inch (EIA310-D) rack. For instructions about how to mount the router in a rack, refer to the installation chapter that is appropriate for your router model.

1 Router modules

You can also mid-mount your 4-, 8- or 16-slot router in a rack using the brackets that ship with the router. You simply remove the brackets from the front of the router and mount them midway along the sides of the router. For more information, see the installation chapter appropriated for your router model.

Brocade MLXe routers can also be mounted in a cabinet or 4-post rack using optional rack mount kits available from Brocade. For information about how to install your Brocade MLXe router in a cabinet or 4-post rack, refer to [“Cabinet or 4-Post Rack Mount Kit contents”](#) on page 77.

Cooling system for Brocade MLXe routers

The cooling systems for Brocade MLXe routers contain the following components:

- 4-slot router: Equipped with one fan assembly that contains two 4-speed fans and two fan controllers to support redundancy.
- 8-slot router: Equipped with one fan assembly containing four 4-speed fans and four fan controllers to support redundancy.
- 16-slot router: Equipped with two high-speed fan assemblies. Each fan assembly contains two 4-speed fans with four fan controllers to support redundancy. High-speed fans are identified in the **show chassis** command output in the following manner:

```
Rev A Back Fan A-1: Status = OK, Speed = LOW (50%)  
Rev A Back Fan A-2: Status = OK, Speed = LOW (50%)
```

- 32-slot router: Equipped with ten fan assemblies. Each fan assembly contains a 4-speed fan. The fan trays support four settings, 50%, 60%, 75%, and 100%, as the normal fan speeds, which are set by the management module.

You can install an optional upward air deflector on the fans of 32-slot routers using a fan deflector kit from Brocade. For more information, refer to [“Cooling system for Brocade MLXe Series routers”](#) on page 38.

[Figure 20](#) and [Figure 21](#) show the fan locations for 4-slot and 8-slot routers. [Figure 22](#) shows the fan locations for 16-slot routers. [Figure 23](#) shows the fan locations for 32-slot routers.

FIGURE 20 Fan locations for Brocade MLXe-4 routers

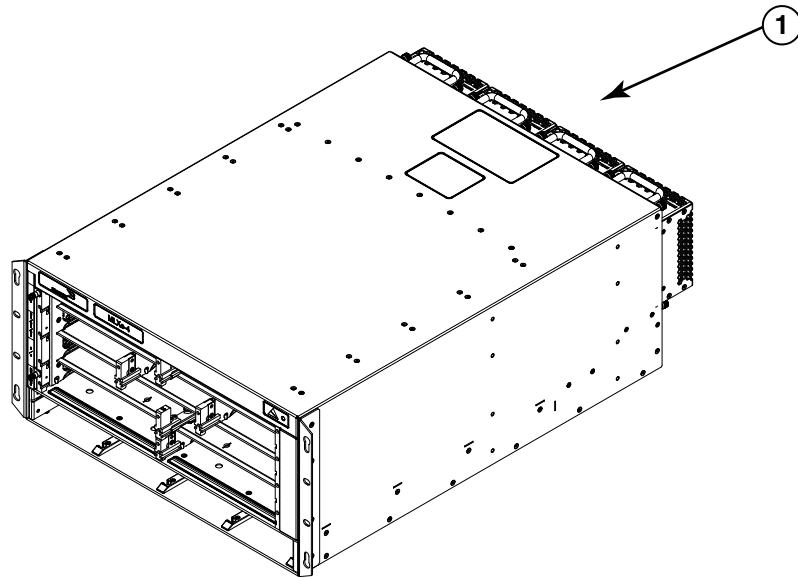

- 1 Fans in rear of chassis

FIGURE 21 Fan locations for Brocade MLXe-8-routers

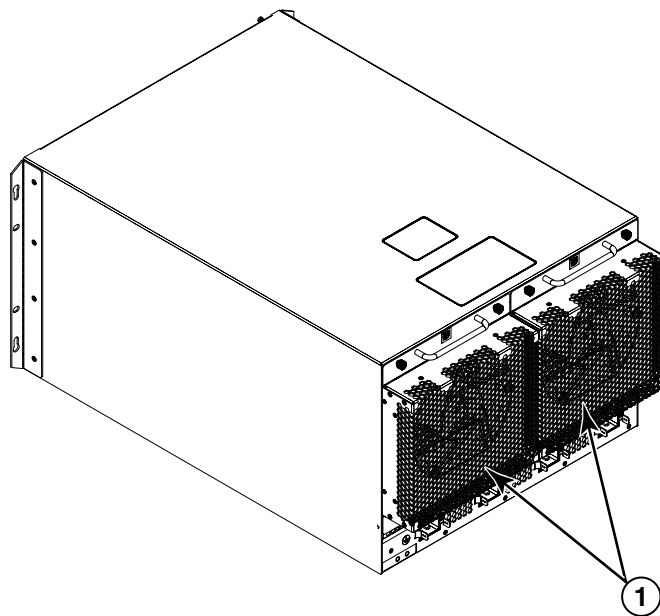

- 1 Fan modules

1 Router modules

FIGURE 22 Rear fan location for Brocade MLXe-16 routers

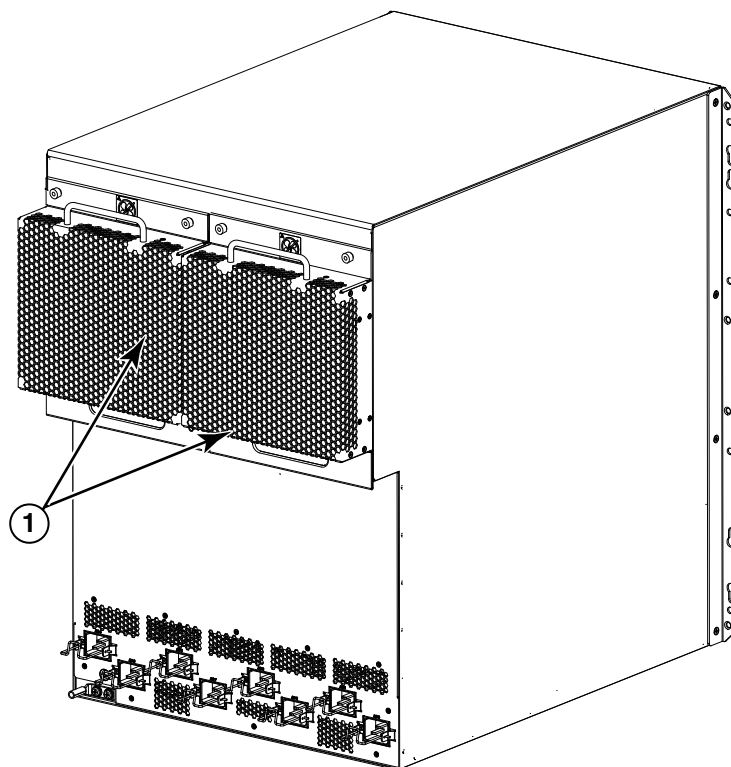

- 1 Rear fan assemblies

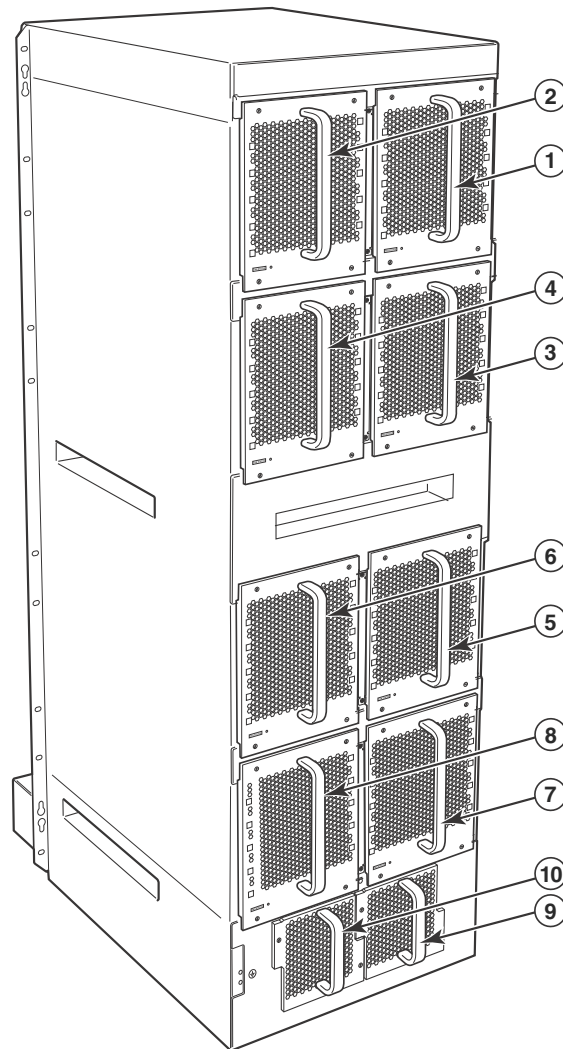
FIGURE 23 Rear fan locations for Brocade MLXe 32-slot routers

1 - 10 Fan modules 1 - 10, numbered as labeled

At startup, the fans operate at high speed. After a period of time, the management module changes the fan speed to low.

By default, the router polls the temperature sensor on each module every 60 seconds for a temperature reading. Depending on the results, the router will:

- Leave the fan speed as is
- Increase the fan speed
- Decrease the fan speed
- Shut down a module to prevent damage

If the temperature of a module exceeds specified high temperature thresholds, the system generates a Syslog message and SNMP trap. The system can also shut down the module if the temperature exceeds the highest threshold.

You can change default low and high temperature thresholds for modules and fan speeds. Refer to [“Changing temperature thresholds for modules and fan speeds”](#) on page 161.

1 Supported software features

The fan control modules include a bi-color LED, which indicates the status of the fans. [Table 18](#) describes the states of this LED.

TABLE 18 Brocade MLXe-32 router fan control LED

LED	Position	State	Meaning
Fan control LED	Rear of router on the fan assembly	Off	The fans are not receiving power.
		Green	The fans are working and responding to commands from the fan control module.
		Red	The fans are not working and not responding to commands the fan control module.

The router ships with fan assemblies fully installed. Fan assemblies are hot-swappable, which means you can remove and replace them without powering down the system.

Cooling system for Brocade MLXe Series routers

The cooling systems for Brocade MLXe routers contain the following components.

- 4-slot router: Equipped with a fan assembly that contains two 4-speed fans and two fan controllers to support redundancy.
- 8-slot router: Equipped with a fan assembly containing four 4-speed fans and four fan controllers to support redundancy.
- 16-slot router: Equipped with three fan assemblies. The fan tray located in the lower front of the router contains six 4-speed fans. There are two fan assemblies located in the rear of the router.
- 32-slot router: Equipped with ten fan assemblies located in the rear of the router. Each fan assembly contains a 4-speed fan. The fan trays support four settings, 50%, 75%, 90%, and 100%, as the normal fan speeds, which are set by the management module.

NIBI-16-FAN-EXH-A high-speed fan assemblies

NIBI-16-FAN-EXH-A high-speed fan assemblies are required for Brocade MLX Series 16-slot routers when you install NI-MLX-10Gx8-M, NI-MLX-10Gx8-D, or NI-MLX-1Gx48-T-A modules. Brocade MLX Series-16 routers ship with high-speed fan assemblies factory installed. Refer to [“Installing NIBI-16-FAN-EXH-A fan assemblies”](#) on page 182 for high-speed fan installation instructions.

Rack mount kit

Brocade MLX Series and Brocade NetIron XMR routers can be mounted in a standard 19-inch (EIA310-D) 2-post rack, using the pre-installed mounting brackets. For flush-mounting, simply use the mounting brackets as installed. For mid-mounting, move the pre-installed brackets from the front edges of the device to the holes provided in the sides of the device. For more information, refer to the appropriate installation chapter for your router model.

Supported software features

For a complete list of software features supported on Brocade MLX Series and Brocade NetIron XMR routers, refer to the *Brocade MLX Series and Brocade NetIron Family Configuration Guide*.

Installing a Brocade MLXe Router

This chapter describes how to install a Brocade MLXe router and its modules in the following sections:

- [“Installation precautions”](#) on page 40
- [“Installing 2x100GbE interface modules in Brocade MLXe routers”](#) on page 43
- [“Installing BR-MLX-10Gx24-DM interface modules in Brocade MLXe routers”](#) on page 46
- [“Installing a Brocade MLXe-8 router”](#) on page 57
- [“Installing a Brocade MLXe-16 router”](#) on page 67
- [“Mounting Brocade MLXe-4, -8, or -16 routers in a 4-post rack or cabinet”](#) on page 77
- [“Installing a Brocade MLXe-32 router”](#) on page 86
- [“Attaching a management station”](#) on page 123
- [“Activating the power source”](#) on page 124
- [“Verifying proper operation”](#) on page 125

The illustrations in this chapter display how to correctly insert the modules and routers. For a complete router module description and slot number identification, refer to [“Brocade MLXe routers”](#) on page 2 of this guide.

NOTE

Illustrations in this chapter may differ slightly from the actual equipment.

Pre-Installation notice for the Brocade MLXe chassis bundles

The following software requirements must be met for any chassis bundle to operate properly.

- All Brocade MLXe-4 and MLXe-8 chassis bundle interface modules and management modules must be running Multi-Service IronWare R05.0.00c or later.
- All Brocade MLXe-16 and MLXe-32 chassis bundle interface modules and management modules must be running Multi-Service IronWare R05.0.00 or later.
- In certain module combinations, you will need to make sure the supported software is loaded.

NOTE

In certain module combinations, a Brocade MLXe system may not have enough power supplies to support the configuration. Check the power specifications for the MLXe chassis and the modules in the “Hardware Specifications” chapter of the installation guide to determine if an additional power supply is required. Additional power supplies can be ordered through Brocade.

For additional information on upgrade procedures, refer to the *Multi-Service IronWare Software Upgrade Guide*.

Installation precautions

Read the following cautions and danger notices before installing Brocade MLXe routers.

General precautions



DANGER

The procedures in this manual are for qualified service personnel.



DANGER

All fiber-optic interfaces use Class 1 Lasers.



CAUTION

Do not install the router in an environment where the operating ambient temperature might exceed 40°C (104°F).



CAUTION

Make sure the air flow around the front, sides, and back of the router is not restricted.



CAUTION

If you do not install a module in a slot, you must keep the slot blank in place. If you operate the router with an uncovered slot, the system may overheat.



CAUTION

Never leave tools inside the router.

Power precautions



CAUTION

Use a separate branch circuit for each AC power cord for redundancy in case one of the circuits fails.



DANGER

Make sure to choose the appropriate circuit device, depending on the number of AC power supplies installed in the router.



DANGER

Disconnect the power cord from all power sources to completely remove power from the router.



DANGER

Make sure that the power source circuits are properly grounded, then use the power cord supplied with the router to connect it to the power source.



DANGER

If the installation requires a different power cord than the one supplied with the router, make sure you use a power cord displaying the mark of the safety agency that defines the regulations for power cords in your country. The mark is your assurance that the power cord can be used safely with the router.



DANGER

Make sure the rack or cabinet housing the router is adequately secured to prevent it from becoming unstable or falling over.



DANGER

Mount the routers you install in a rack or cabinet as low as possible. Place the heaviest router at the bottom and progressively place lighter routers above.



CAUTION

Ensure that the router does not overload the power circuits, wiring, and over-current protection. To determine the possibility of overloading the supply circuits, add the ampere (amp) ratings of all devices installed on the same circuit as the router. Compare this total with the rating limit for the circuit. The maximum ampere ratings are usually printed on the routers near the input power connectors.



CAUTION

Brocade MLXe routers with DC power sources are intended for installation in restricted access areas only. A restricted access area is where access can be gained only by service personnel through the use of a special tool, lock and key, or other means of security, and is controlled by the authority responsible for the location.



CAUTION

Brocade MLXe routers with AC power sources are intended for installation in restricted access areas only. A restricted access area is a location where access can be gained only by service personnel through the use of a special tool, lock and key, or other means of security.



CAUTION

For the DC input circuit to the system of Brocade MLXe-4, Brocade MLXe-8, and Brocade MLXe16 routers (1200W supply), make sure there is a 40 amp circuit breaker, minimum -48VDC, double pole, on the input lugs to the power supply. The input wiring for connection to the product should be copper wire, 6 AWG, marked VW-1, and rated minimum 90°C.



CAUTION

For the NEBS-compliant installation of Brocade MLXe-4, Brocade MLXe-8, and Brocade MLXe-16 routers with AC and DC systems, use a ground wire of at least 6 American Wire Gauge (AWG). The ground wire should have an agency-approved crimped connector (provided with the device) attached to one end, with the other end attached to building ground. The connector must be crimped with the proper tool, allowing it to be connected to both ground screws on the enclosure. Before crimping the ground wire into the provided ground lug, ensure the bare copper wire has been cleaned and antioxidant is applied to the bare wire.



CAUTION

For the NEBS-compliant installation of Brocade MLXe-32, routers with AC and DC systems, use a ground wire of at least 2 American Wire Gauge (AWG). The ground wire should have an agency-approved crimped connector (provided with the device) attached to one end, with the other end attached to building ground. The connector must be crimped with the proper tool,

allowing it to be connected to both ground screws on the enclosure. Before crimping the ground wire into the provided ground lug, ensure the bare copper wire has been cleaned and antioxidant is applied to the bare wire.

Installing 2x100GbE interface modules in Brocade MLXe routers

This section provides installation instructions for 2x100G interface modules.

Installation considerations

- 2x100G modules occupy two adjacent slots. When you install a 2x100G module, the odd numbered (low number) slot of the slot pair becomes the active slot, and the even numbered slot (higher number) is blocked.
The acceptable slots in which to install this module are odd-numbered interface module slots (1, 3, 5, 7, 9, 11, 13, and 15 for a 16-slot chassis, for example). Adjacent even-numbered slots will be in blocked state. In all cases, the lower number (odd number) becomes the active slot and the higher number (even number) becomes the blocked slot.
- 2x100G modules **cannot** be installed in the following scenarios.
 - If there is another type of module installed in either of the slots
 - If either slot is configured as something else. Before you install your 2x100G module, you will need to reconfigure the slot using the **no module** command.
- The following conditions will prevent a 2x100G interface module from operating properly.
 - If either of the two slots required to house the module is already configured for another type of module.
If the higher-number slot (even number) is configured for another type of module, you must reconfigure it by entering the **no module** command.
 - If there is a module of another type installed in either of the slots. You must remove the existing module, remove the center slot guide, and reconfigure the higher-numbered (even number) of the two slots as **no module**.
- For maximum performance you must operate your 2x100G module with high speed switch fabric modules in turbo mode.

Installation procedure

When installing modules, wear an ESD wrist strap with a plug for connection to the ESD connector on the router chassis or other suitable ground.



DANGER

For safety reasons, the ESD wrist strap should contain a 1 megohm series resistor.

2 Installing 2x100GbE interface modules in Brocade MLXe routers

1. Upgrade the software on all management modules and interface modules to Multi-Service IronWare R05.5.00 or later. For specific upgrade instructions, refer to the *Multi-Service IronWare Upgrade Guide*.
2. Before you install your 2x100G interface module into a working device, you must change the system **tm-credit-size** to 1024b (which readies the device to forward 100 Gbps traffic). Log into your system and enter the following commands in the configuration level of the CLI. Remember to write to memory and reload the device.

```
Brocade# config
Brocade(config)# system-init tm-credit-size credit_1024b
Brocade(config)# exit
Brocade# write memory
Brocade# reload
```

NOTE

The **system-init tm-credit-size** command is only available in R05.2.00 or later, so it is important to upgrade all software to R05.5.00 or later before you install your 2x100G module.

3. Remove the center slot guide. In some devices, you must lift a plunger to remove the center slot guide. Be sure to keep the plunger raised so that it does not reseat while you are removing the guide. In some devices, you must loosen a screw to remove the center slot guide. [Figure 24](#) shows the two types of center slot guides.

Remove the guide carefully so that it does not move from side to side. Excess movement of the guide may damage pins on the backplane before it is fully removed from the chassis.

NOTE

Do not discard the center slot guide, as you will need it if you want to revert to a 2-slot configuration. If you misplace your center slot guide, you can purchase a replacement from Brocade.

FIGURE 24 Removing the center slot guide

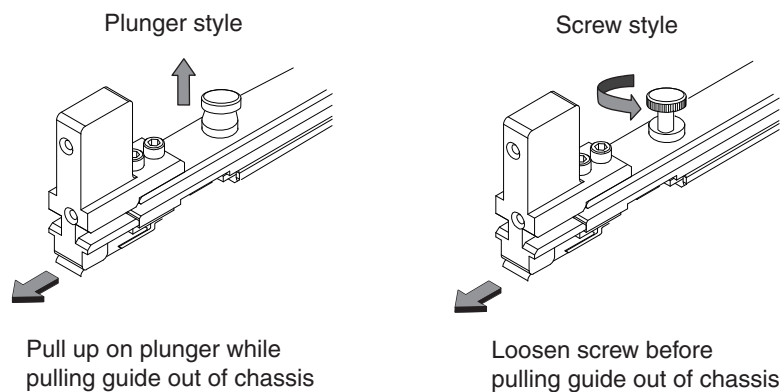

4. Remove the two connector covers from the rear connectors of the module. Refer to [Figure 25](#).
5. Remove the port cover from one or both ports, depending on how you plan to use your module. If you are using one port only (always Port 1), you must leave the port cover in the inactive port (always Port 2). Port covers are designed for a tight fit and will take some effort to remove. Refer to [Figure 25](#).

NOTE

Do not use the port cover tabs to lift the module. They are not designed to support the weight of the module, which can fall and be damaged.

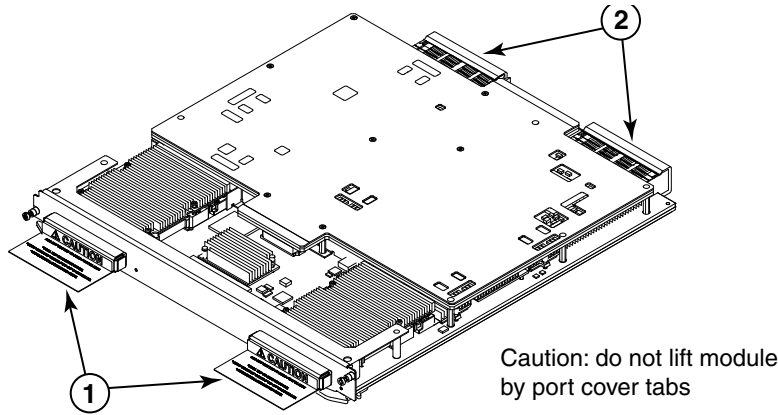
FIGURE 25 Port covers and connector covers

6. Insert the module into the slot until the connectors securely engage the backplane.

In 4- and 8-slot devices, the modules are installed horizontally. In 16- and 32-slot devices the modules are installed vertically. [Figure 26](#) and [Figure 27](#) show how to install 2x100G modules in horizontal and vertical slots (4-slot and 16-slot devices are shown, but the process is the same for 8-slot and 32-slot devices).

NOTE

The 2x100G interface module is sensitive to dust and debris. Keep the optics covers in place until you are ready to connect the fiber cable. Clean all fiber cables properly before you connect them to the 2x100G interface module.

FIGURE 26 Installing 2x100G modules in a 4- or 8-slot device (4-slot shown)

FIGURE 27 Installing 2x100G modules in a 16- or 32-slot device (16-slot shown)



Installing BR-MLX-10Gx24-DM interface modules in Brocade MLXe routers

This section provides installation instructions for BR-MLX-10Gx24-DM interface modules.

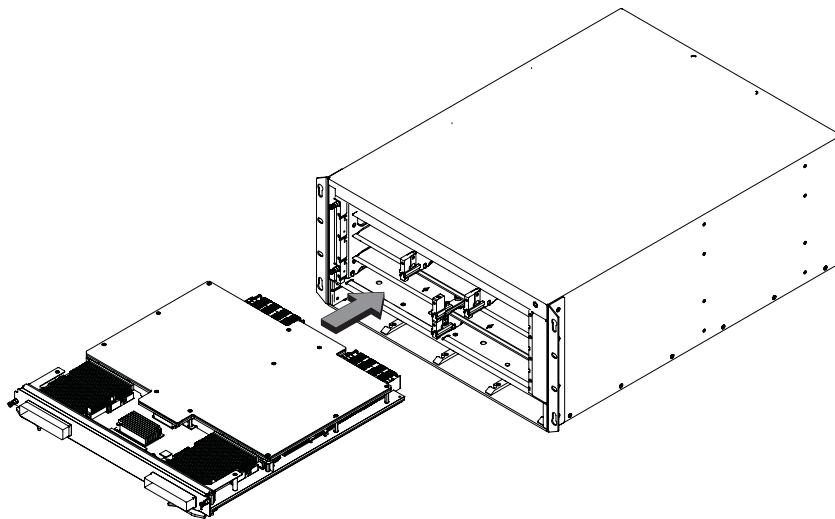
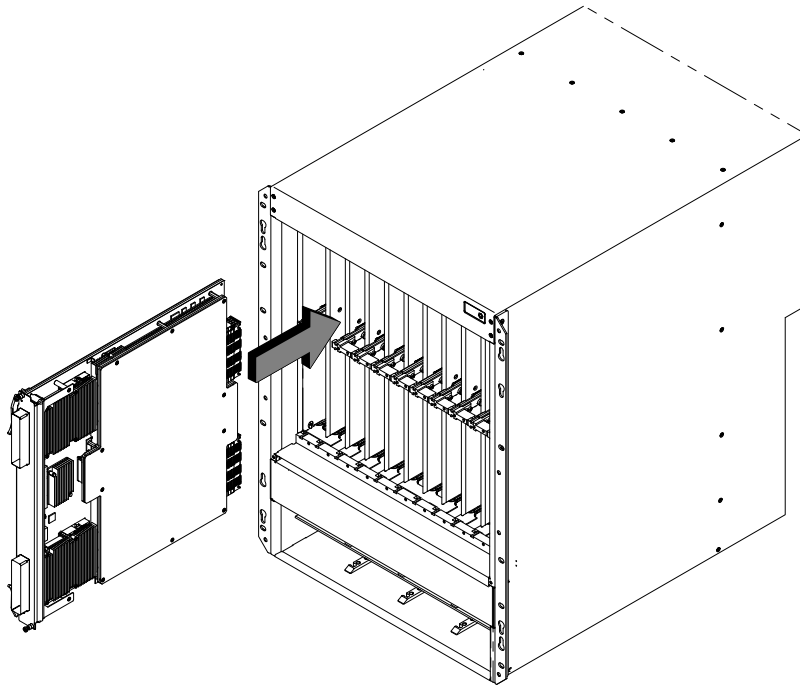
Installation considerations

- BR-MLX-10Gx24-DM interface modules can be installed only in Brocade MLXe devices running in MLX mode (NI-MLX-MR and BR-MLX-MR2-M or the equivalent 32 slot management modules).
- BR-MLX-10Gx24-DM interface modules are supported only on devices running Netron R05.4.00 or later. For the latest upgrade instructions, refer to the *Multi-Service IronWare Upgrade Guide* on the Brocade web site.
- Pull off the GBX connector cover before installing the module in the chassis.
- Use **show chassis** command to determine if you need additional power supplies
- For installation in an MLXe-32 chassis, configure the chassis differently based on whether it has a Gen-1 module or not.
- The following conditions may prevent a BR-MLX-10Gx24-DM interface module from coming up properly:
 - BR-MLX-10Gx24-DM interface modules require the **snmp-server max-ifindex-per-module 40|64** configured. Otherwise, the cards will not come up.

NOTE

Not all features available in NetIron R05.4.00 are supported on the BR-MLX-10Gx24-DM interface module. To verify if a particular feature is supported with the BR-MLX-10Gx24-DM interface module, refer to the latest version of the *Multi-Service IronWare Configuration Guide*.

NOTE

For maximum performance, you must operate your BR-MLX-10Gx24-DM interface module with high speed switch fabric modules in turbo mode. For information on switch fabric modules, refer to [“Managing switch fabric modules”](#) on page 159.

Installation procedure

When installing modules, wear an ESD wrist strap with a plug for connection to the ESD connector on the router chassis or other suitable ground.

**DANGER**

For safety reasons, the ESD wrist strap should contain a 1 megohm series resistor.

1. Upgrade the software on all management modules and interface modules to Multi-Service IronWare R05.4.00 or later. For specific upgrade instructions, refer to the *Multi-Service IronWare Upgrade Guide*.

2. Configure the snmp maximum interface index per module to 64 using the **snmp-server max-ifindex-per-module 64** command

```
Brocade (config)# snmp-server max-ifindex-per-module 64
```

3. For MLXe-32 installations only:

- a. If the chassis has a Gen-1 module, enter the following commands.

```
Brocade# config
Brocade(config)# system-init mlxe32-24x10g-enable max-tm-queue-4
Brocade(config)# system-init fabric-data-mode force-normal
Brocade# write memory
Brocade# reload
```

- b. If the chassis has no Gen-1 module, enter the following commands.

```
Brocade# config
Brocade(config)# system-init mlxe32-24x10g-enable
Brocade# write memory
Brocade# reload
```

4. Install the BR-MLX-24x10G-DM module.
5. Verify that the module comes up,

NOTE

For known limitations, please refer to the Release Notes shipped with your module.

Installing a Brocade MLXe-4 router

This section describes how to install a Brocade MLXe-4 router.

Preparing the installation site

Before installing the router, plan the location and orientation relative to other devices and equipment. For cooling purposes, allow a minimum of six inches of space between the sides, front, and the back of the router and walls or other obstructions. If a router is installed in a perforated enclosure, the perforations must cover at least 60 percent of the surface.

NOTE

This equipment is suitable for installation in a Network Telecommunication facility and where NEC requirements apply. Additionally, it may be installed in either a Common Bonding Network (CBN) or Isolated Bonding Network (IBN). It is not intended for Outside Plant (OSP) installations.

Ensure that the proper cabling is installed at the site.

For information on cabling, refer to [“Installing power supplies in a Brocade MLXe-4 router”](#) on page 53, [“Attaching a management station”](#) on page 123, and [“Connecting the router to a network device”](#) on page 145.

Unpacking a Brocade MLXe-4 router

The Brocade MLXe-4 router ships with the following items:

- Router chassis with switch fabric modules installed in slots marked SF, slot blanks installed in all empty module slots, and mounting brackets attached for front-mount.
- Insertion or extraction tool for use with RJ45 and fiber-optic connectors.

NOTE

If any items are missing, contact the place of purchase.

Follow these steps to unpack your Brocade MLXe-4 router.

1. Remove the router from the shipping carton.
2. Save the shipping carton and packing materials in case you need to move or ship the router at a later time.

Installing a Brocade MLXe-4 router in a rack or cabinet

Your Brocade MLXe-4 router ships from the factory with mounting brackets attached. You can mount your router in the following ways:

- Front-mount in a standard two-post rack using the factory-installed brackets.
- Mid-mount in a standard two-post rack by moving the factory-installed brackets to the center of the device
- Mount the device in a four-post rack or cabinet using the Cabinet Mount Kit. Refer to [“Installing Brocade MLXe-4 and Brocade MLXe-8 routers in a cabinet or 4-post rack”](#) on page 77.

NOTE

Because of the weight of a fully loaded Brocade MLXe-4 router, Brocade recommends mounting it in a rack before installing the modules and AC power supplies.

You can install up to eight Brocade MLXe-4 routers in a standard 19-inch (EIA310-D) two-post rack using the factory-installed mounting brackets for either front- or mid-mounts.

Mounting your device in a standard 2-post rack

The factory-installed mounting brackets allow you to front-mount or mid-mount your device in the rack. For a mid-mount, you must remove the factory installed brackets from the front edge of the device and install them using the holes in the center-sides of the device. Refer to [Figure 29](#).

You will need to provide four standard #12-24 pan-head screws (per router) to secure routers in the rack. You will also need a #2 Phillips screwdriver. Complete the following steps.

NOTE

When connecting the device to the rack frame, use thread-forming screws and paint-piercing washers.

1. Determine the position of each router in the rack according to the weight of the router. For example, mount the router with the fewest modules near the top of the rack, a router with more modules near the middle of the rack, and fully populated routers near the bottom of the rack.
2. Using the keyhole slots in the router mounting brackets as a guide, align one screw per rack post, as shown in [Figure 28](#). On one side of the rack, the screw should align with the top hole in the mounting bracket. On the other side of the rack, the screw should align with the bottom hole of the mounting bracket. When tightening these screws, leave approximately 1/4 inch of clearance between the back of the screw head and the rack post.

FIGURE 28 Positioning the mounting screws in rack posts

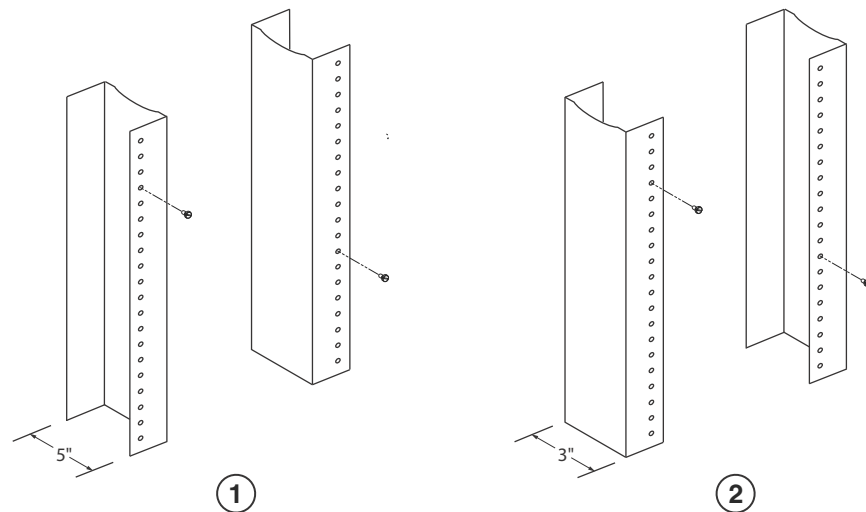

1 Unequal flange equipment rack

2 Network equipment rack

3. Mount the lowest router first. With one person on each side, lift the router and slip the widest part of each keyhole slot on the mounting bracket over the corresponding screw in the rack post. See [Figure 29](#).

2 Installing a Brocade MLXe-4 router

FIGURE 29 installing the router in a rack

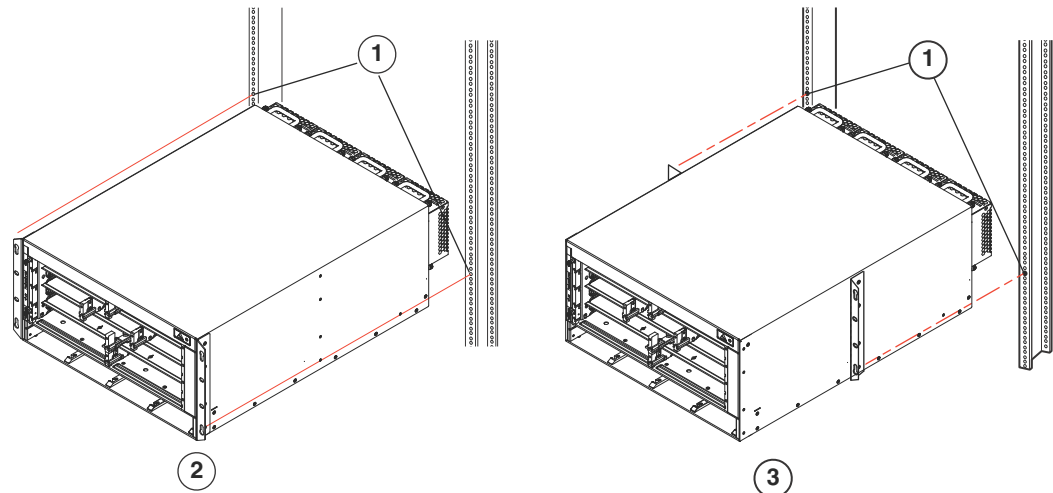

- 1 Screws on mounting posts
 - 2 Front-mount position
 - 3 Mid-mount position
4. Slide the router down so that the mounting screw heads are in the narrowest part of the keyhole slots.
 5. Tighten the screws to secure the router in place. For extra support, use additional screws.

NOTE

For better grounding of the router to the rack, attach the router using star washers. You should also use star washers with any single-hole grounding lugs to keep the lugs from rotating.

6. Repeat step 2 through step 5 to mount each router in the rack, moving from lowest to highest.

Installing Brocade MLXe-4 modules

The sequence for installing multiple modules is important to ensure proper fit. The recommended sequence for the Brocade MLXe-4 router is to install right-to-left, beginning with the lowest row and moving up.

For instructions about installing 2x100GbE interface modules, refer to [“Installing 2x100GbE interface modules in Brocade MLXe routers”](#) on page 43.

For instructions about installing 2x100GbE interface modules, refer to [“Installing BR-MLX-10Gx24-DM interface modules in Brocade MLXe routers”](#) on page 46.

NOTE

Installation procedures are identical for interface, management and switch fabric modules.



DANGER

The intra-building ports of the equipment or subassembly is suitable for connection to intra-building or unexposed wiring or cabling only. The intra-building ports of the equipment or subassembly MUST NOT be metallically connected to interfaces that connect to the outside plant (OSP) or its wiring. These interfaces are designed for use as intra-building interfaces only (Type 2

or Type 4 ports as described in GR-1089-CORE, Issue 5) and require isolation from the exposed OSP cabling. The addition of Primary Protectors is not sufficient protection in order to connect these interfaces metallicity to OSP wiring.

NOTE

Brocade MLXe modules are dedicated, which means that you must install them in Brocade MLXe routers only. If you install a Brocade MLXe module in a non-Brocade MLXe router, or install a module intended for a non-Brocade MLXe router in a Brocade MLXe router, the router and module will not function properly.

Although management modules are designed to be hot-swappable, you must upgrade the software on all interface modules and management modules to the appropriate software release before installing them. For more information on the appropriate software release, refer to the Hardware Installation Notes that shipped with the management module.

For information about how to disable and re-enable power to interface modules, see [“Disabling and re-enabling power to interface modules”](#) on page 151

[Table 19](#) identifies the router slot numbers where the modules must be installed. An identifying label can be seen at the base of each slot.

NOTE

The Brocade MLXe-4 router ships with the required switch fabric modules installed.

TABLE 19 Brocade MLXe-4 module installation

Module	Slot number
Management modules	Active module – M1 (left). Redundant module – M2 (right).
Interface modules	1 – 4
Switch fabric modules	SF1 – SF3

If you are installing a redundant management module, see the chapter titled “Using a Redundant Management Module” in the *Brocade MLX Series and Brocade NetIron Family Configuration Guide* for information about how the redundant module works, optional software configurations, and how to manage redundancy.

You can install modules while the router is powered on and running.

Before installing a new interface module, you will need to remove the slot blank from the module slot. You should also have the following items available:

- A 1/4 inch #8 flat-blade screwdriver, or a #2 Phillips screwdriver
- A new interface module, which you can order from Brocade
- An ESD wrist strap with a plug for connection to the ESD connector on the Brocade MLXe router.



DANGER

For safety reasons, the ESD wrist strap should contain a 1 megohm series resistor.

The Brocade MLXe-4 router ships with slot blanks installed in all empty module slots. The slot blanks help ensure proper airflow inside the router. You must remove the slot blank to install a module into a slot.



CAUTION

If you do not install a module in a slot, you must keep the slot blank in place. If you operate the router with an uncovered slot, the system may overheat. Tighten the screws that secure the slot blanks so that they remain in place when removing adjacent panels or modules.



CAUTION

If you are hot-swapping a module, allow a minimum of two seconds after a module (or power supply or fan tray) has been removed before inserting a module in the same slot.

Although the slot blanks differ in size, the procedure for removing them is identical. You will need a flat-blade screwdriver to remove slot blanks.

Follow these steps to remove a slot blank.

1. Loosen the screws on either end of the slot blank by hand or with a flat-blade screwdriver.
2. Pull the slot blank out of the router, and store it in a safe place for future use.

Follow these steps to install a module.

1. If you are installing a module in a slot which may have been configured for a different module type, remove the old configuration information by following these steps.

- a. Use the **show running-config** command in config mode to determine the current configuration of the slot.

```
Brocade(config)# show running-config
Current configuration:
!
ver V5.0.0T163
module 1 ni-mlx-20-port-1g-copper
!
```

This example shows that slot 1 has already been configured for a 20-port 1 Gbps copper interface module.

- b. Enter the **no module slot-number module-type** command to remove the configuration from slot 1, using the information shown as a result of the **show running-config** command.

```
Brocade(config)# no module 1 ni-mlx-20-port-1g-copper
```

This example removes the existing configuration from slot 1, leaving it ready for a new module.

2. Put on the ESD wrist strap and ground yourself by inserting the plug into the ESD connector on the front of the chassis.
3. Remove the module from the packaging.
4. Insert the module into the router slot, and slide the card along the card guide until the ejectors on either side of the module move close to the module front panel. Refer to [Figure 30](#).

NOTE

When inserting the module into the router, be sure that the faceplate does not overlap the faceplate of an adjacent module.

5. Rotate the ejectors until they are flush with the module front panel. This action will fully seat the module in the backplane.
6. Tighten the screws at each end of the module faceplate by pushing them in and turning them clockwise. Complete the tightening process using the flat-blade screwdriver.
7. Enter the **write memory** command to ensure that the slot will be correctly configured for the new module after a reboot.

```
Brocade(config)# write memory
Write startup-config done.
```

FIGURE 30 Installing a module

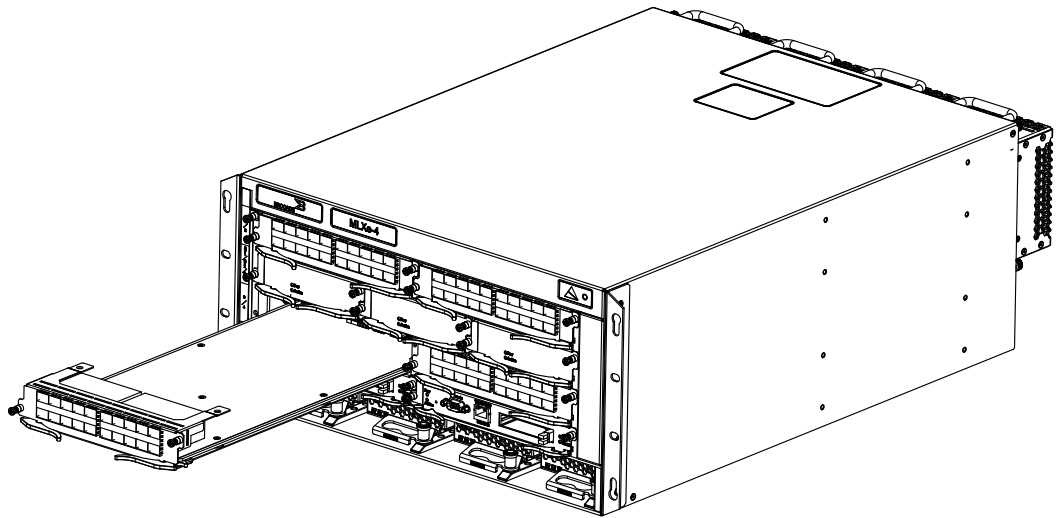

Installing power supplies in a Brocade MLXe-4 router

Follow these steps to install a power supply.

1. Remove the power supply slot blank and store it for future use.
2. Remove the power supply from the packaging.
3. Insert the power supply into the slot and slide it along the guides on each side of the slot. Refer to [Figure 31](#).

NOTE

Empty power supply slots must be covered with slot blanks.

**CAUTION**

Carefully follow the mechanical guides on each side of the power supply slot and make sure the power supply is properly inserted in the guides. Never insert the power supply upside down.

FIGURE 31 Installing a power supply

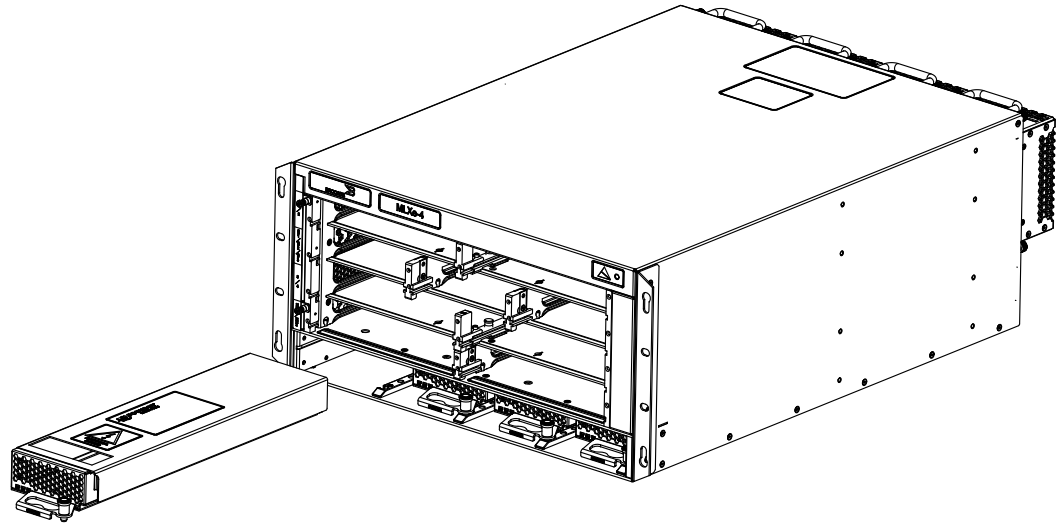

4. Push the power supply front panel into the router until it engages the backplane connector, and the latch pin clicks into place.

For information about connecting power to the router, refer to [“Connecting AC power”](#) on page 54 or [“Connecting DC power”](#) on page 55.

Connecting AC power

AC power is supplied through a power cord connected to the AC power supply installed in the router.

NOTE

For the NEBS-compliant installation, AC power connections must use a surge protection device (SPD) to protect the AC power supplies from damage due to excessive power line surges.

Follow these steps to connect the AC power cord.

1. Locate the power supply AC inlet on rear of chassis for the associated installed power supply.
2. Lift the cord retainer and connect the AC power cord to the AC inlet.
3. Snap the cord retainer over the power plug to hold it in place.



DANGER

If the installation requires a different power cord than the one supplied with the router, make sure you use a power cord displaying the mark of the safety agency that defines the regulations for power cords in your country. The mark is your assurance that the power cord can be used safely with the router.

For information about powering on the system, refer to [“Activating the power source”](#) on page 124.

Connecting DC power

You can provide DC power for the Brocade MLXe-4 router by installing a DC-to-DC power supply. The DC-to-DC supply converts 48V-DC input from a power source to 12V-DC for your router.



DANGER

The procedure in this section is for qualified service personnel.

NOTE

Because there are multiple power supply vendors, the LED layout on your DC power supply may differ from what is shown in [Figure 32](#). However, the LED functions are identical.

Follow these steps to connect a DC power source.

1. Use a #1 Phillips screwdriver to remove the two screws that hold the transparent cover over the power supply lugs, as shown in [Figure 32](#).

FIGURE 32 The Brocade MLXe-4 DC power supply

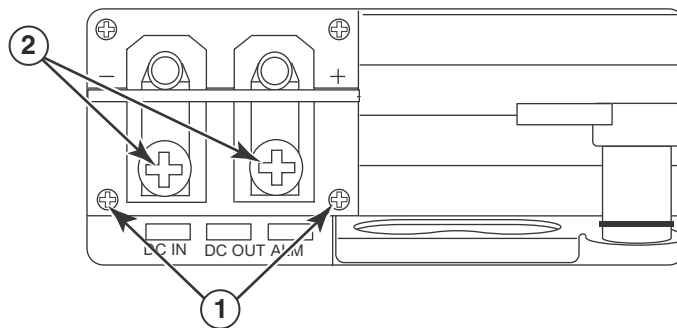

1 Screws holding transparent cover

2 Power lug screws

2. Use a #2 Phillips screwdriver to remove the power lugs.
3. Crimp #8 AWG power supply wire into the power lugs and reconnect the lugs to the power supply unit. Refer to [Figure 33](#).



CAUTION

For the NEBS-compliant installation of Brocade MLXe-4, Brocade MLXe-8, and Brocade MLXe-16 routers with AC and DC systems, use a ground wire of at least 6 American Wire Gauge (AWG). The ground wire should have an agency-approved crimped connector (provided with the device) attached to one end, with the other end attached to building ground. The connector must be crimped with the proper tool, allowing it to be connected to both ground screws on the enclosure. Before crimping the ground wire into the provided ground lug, ensure the bare copper wire has been cleaned and antioxidant is applied to the bare wire.

2 Installing a Brocade MLXe-4 router



CAUTION

For the NEBS-compliant installation of Brocade MLXe-32, routers with AC and DC systems, use a ground wire of at least 2 American Wire Gauge (AWG). The ground wire should have an agency-approved crimped connector (provided with the device) attached to one end, with the other end attached to building ground. The connector must be crimped with the proper tool, allowing it to be connected to both ground screws on the enclosure. Before crimping the ground wire into the provided ground lug, ensure the bare copper wire has been cleaned and antioxidant is applied to the bare wire.



CAUTION

To ensure adequate bonding when attaching the ground lug, a minimum of 20 PSI of torque is required to be applied to the mounting hardware used to attach the ground lug.

FIGURE 33 Crimping the power supply wire in the lug

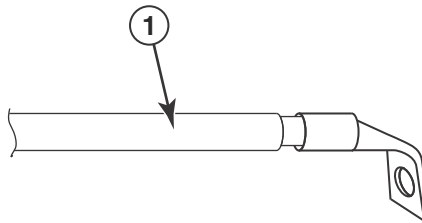

1. AWG power supply wire:
#8 AWG power supply wire for 1200W power supplies
#6 AWG power supply wire for 1800W power supplies
4. Connect the -48V cable to the negative terminal and the 0V cable to the positive terminal.

NOTE

DC return must be isolated from the router ground (DC-I) when connecting to DC power supplies.

5. Replace the transparent cover over the lugs.

This equipment installation must meet NEC/CEC code requirements. Consult local authorities for regulations.

Final steps

Complete these steps in the order listed:

- [“Attaching a management station”](#)
- [“Activating the power source”](#)
- [“Verifying proper operation”](#)

Installing a Brocade MLXe-8 router

This section describes how to install a Brocade MLXe-8 router.

NOTE

Illustrations in this chapter may differ slightly from the actual equipment.

Preparing the installation site

Before installing the router, plan the location and orientation relative to other devices and equipment. For cooling purposes, allow a minimum of six inches of space between the sides, front, and the back of the router and walls or other obstructions. If a router is installed in a perforated enclosure, the perforations must cover at least 60 percent of the surface.

NOTE

This equipment is suitable for installation in a Network Telecommunication facility and where NEC requirements apply. Additionally, it may be installed in either a Common Bonding Network (CBN) or Isolated Bonding Network (IBN). It is not intended for Outside Plant (OSP) installations.

Ensure that the proper cabling is installed at the site.

For information on cabling, refer to [“Installing power supplies in the Brocade MLXe-8 router”](#) on page 63, [“Attaching a management station”](#) on page 123, and [“Connecting the router to a network device”](#) on page 145.

Unpacking a Brocade MLXe-8 router

The Brocade MLXe-8 router ships with the following items:

- Switch fabric modules installed in slots marked SF, and slot blanks installed in all empty module slots.
- Two AC or two DC power supplies
- Insertion or extraction tool for use with RJ45 and fiber-optic connectors.

Save the shipping carton and packing materials in case you need to move or ship the router at a later time.

Lifting guidelines for Brocade MLXe-8 routers

Follow these guidelines for lifting and moving Brocade MLXe-8 routers:

2 Installing a Brocade MLXe-8 router

- Before lifting or moving the router, disconnect all external cables.
- Do not attempt to lift a fully configured router by yourself.
- It is recommended that you install router components after you have installed the router in a rack.

Installing a Brocade MLXe-8 router in a rack

Because of the weight of a fully loaded Brocade MLXe-8 router, Brocade recommends mounting it in a rack before installing the modules and AC power supplies.

You can install up to six Brocade MLXe-8 routers in a standard 19-inch (EIA310-D) rack using the standard rack installation method. If you use the cabinet mounting kit, you can install up to 4 Brocade MLXe-8 routers in a standard 19-inch rack.

Front- or mid-mount your device in a standard rack

Your Brocade MLXe-8 router ships from the factory with mounting brackets attached for front-mount installation in a standard 2-post rack. You can also use these brackets for a mid-mount installation by simply removing the brackets from the front edges of the device and re-attaching them in the center sides of the device using the pre-drilled holes. Refer to [Figure 35](#).

You will need to provide four standard #12-24 pan-head screws (per router) and a #2 Phillips screwdriver to secure routers in the rack.

If you are installing your Brocade MLXe-8 router in a cabinet or 4-post rack, refer to [“Installing Brocade MLXe-4 and Brocade MLXe-8 routers in a cabinet or 4-post rack”](#) on page 77.

NOTE

When connecting the device to the rack frame, use thread-forming screws and paint-piercing washers.

Follow these steps to mount your device in a standard 2-post rack in either a front- or mid-mount configuration.

1. Determine the position of each router in the rack according to weight. For example, mount the router with the fewest modules near the top of the rack, the router with more modules near the middle of the rack, and a fully populated router near the bottom of the rack.
2. Using the keyhole slots in the router mounting brackets as a guide, align one screw per rack post, as shown in [Figure 34](#). On one side of the rack, the screw should align with the top hole in the mounting bracket. On the other side of the rack, the screw should align with the bottom hole of the mounting bracket. When tightening these screws, leave approximately 1/4 inch of clearance between the back of the screw head and the rack post.

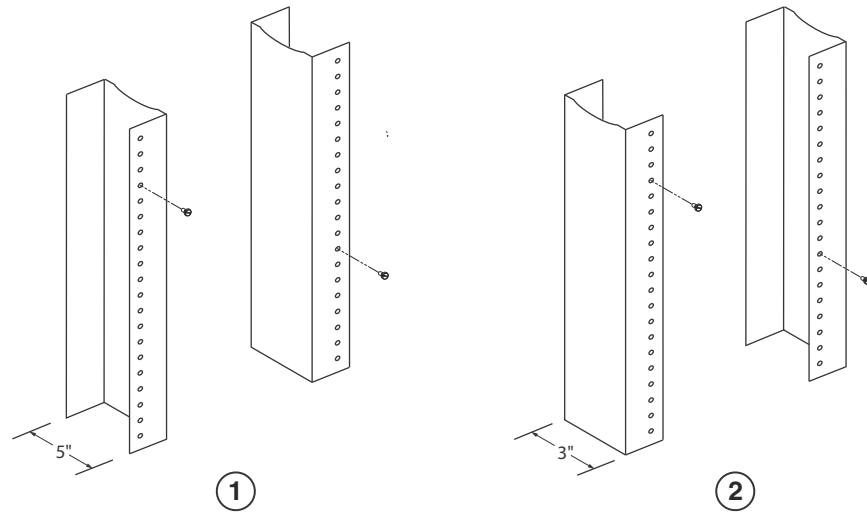
FIGURE 34 Positioning the mounting screws in rack posts

1 Unequal flange equipment rack

2 Network equipment rack

3. Mount the lowest router first. With one person on each side, lift the router and slip the widest part of each keyhole slot on the mounting bracket over the corresponding screw in the rack post. See [Figure 35](#).

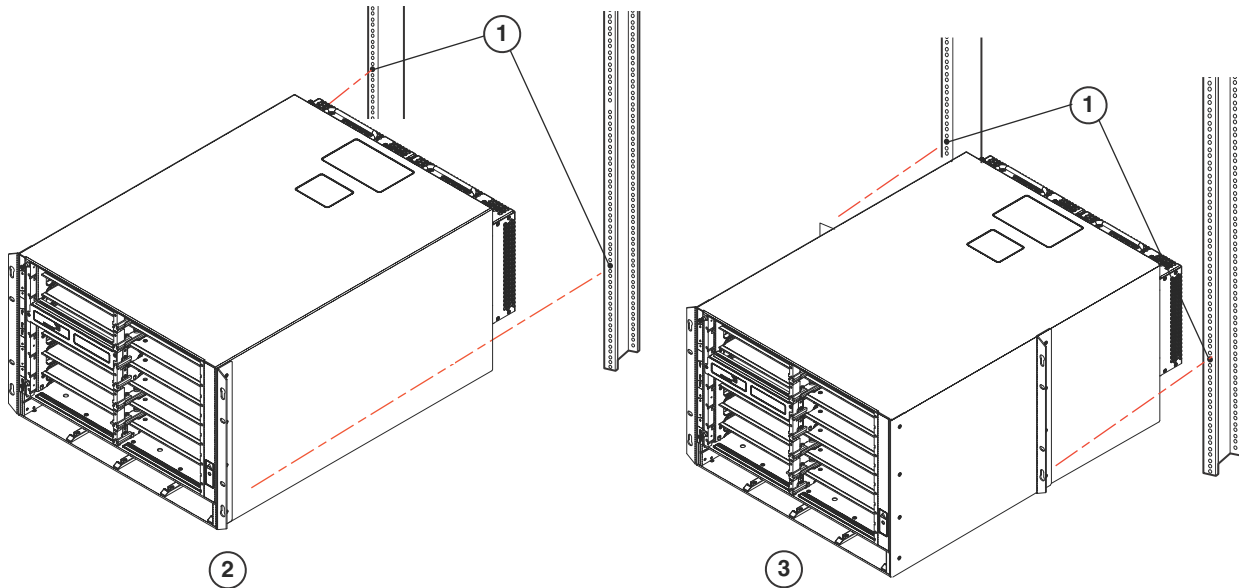
FIGURE 35 Mounting the router in a rack

1 Screws in mounting posts

2 Front-mount position installation

3 Mid-mount installation

4. Slide the router down so that the mounting screw heads are in the narrowest part of the keyhole slots.
5. Tighten the screws to secure the router in place. For extra support, use additional screws.

NOTE

For better grounding of the router to the rack, attach the router using star washers. You should also use star washers with any single-hole grounding lugs to keep the lugs from rotating.

Repeat step 2 through step 5 to mount each router in the rack, moving from lowest to highest.

Installing Brocade MLXe-8 modules

The sequence for installing multiple modules is important to ensure proper fit. The recommended sequence for the Brocade MLXe-8 router is to install right-to-left, beginning with the lowest row and moving up.

The Brocade MLXe-8 router ships with the required switch fabric modules installed.

For instructions about installing 2x100GbE interface modules, refer to [“Installing 2x100GbE interface modules in Brocade MLXe routers”](#) on page 43.

For instructions about installing BR-MLX-10Gx24-DM interface modules, refer to [“Installing BR-MLX-10Gx24-DM interface modules in Brocade MLXe routers”](#) on page 46.

NOTE

installation instructions are identical for interface, management, and switch fabric modules.



DANGER

The intra-building ports of the equipment or subassembly are suitable for connection to intra-building or unexposed wiring or cabling only. The intra-building ports of the equipment or subassembly MUST NOT be metallically connected to interfaces that connect to the outside plant (OSP) or its wiring. These interfaces are designed for use as intra-building interfaces only (Type 2 or Type 4 ports as described in GR-1089-CORE, Issue 5) and require isolation from the exposed OSP cabling. The addition of Primary Protectors is not sufficient protection in order to connect these interfaces metallically to OSP wiring.

NOTE

Brocade MLXe modules are dedicated, which means that you must install them in the Brocade MLXe router only. If you try to install a Brocade MLXe module in a non-Brocade MLXe router, or install a module intended for a non-Brocade MLXe router in a Brocade MLXe router, the router and module will not function properly.

Although management modules are designed to be hot-swappable, you must upgrade the software on all interface modules and management modules to the appropriate software release before installing them. For more information on the appropriate software release, refer to the Hardware Installation Notes that shipped with the management module.

[Table 20](#) identifies the router slot numbers where the modules must be installed. An identifying label can be seen at the base of each slot.

TABLE 20 Brocade MLXe-8 module slot designations

Module	Slot number
Management modules	Active module – M1 (left). Redundant module – M2 (right).
Interface modules	1 – 8
Switch fabric modules	SF1 – SF3

For information about how to disable and re-enable power to interface modules, see [“Disabling and re-enabling power to interface modules”](#) on page 151

If you are installing a redundant management module, refer to the chapter titled “Using a Redundant Management Module” in the *Brocade MLX Series and Brocade NetIron Family Configuration Guide* for information about how the redundant module works, optional software configurations, and how to manage redundancy.

Before installing a module in the Brocade MLXe-8 router, have the following items available:

- A large flat-blade screwdriver.
- An ESD wrist strap with a plug for connection to the ESD connector on the router.



DANGER

For safety reasons, the ESD wrist strap should contain a 1 megohm series resistor.

You can install modules while the router is powered on and running.

The router ships with slot blanks installed in all empty module slots. The slot blanks help ensure proper airflow inside the router. You must remove the slot blank to install a module.



CAUTION

If you do not install a module in a slot, you must keep the slot blank in place. If you run the router with an uncovered slot, the system may overheat. Tighten the screws that secure the slot blanks so that they remain in place when removing adjacent panels or modules.

Although the slot blanks differ in size, the procedure for removing them is identical. You will need a flat-blade screwdriver to perform this task.

Follow these steps to remove a slot blank.

1. Loosen the screws on either end of the slot blank by hand or with a flat-blade screwdriver.
2. Pull the slot blank out of the router, and store it in a safe place for future use.



CAUTION

If you are hot-swapping a module, allow a minimum of two seconds after a module (or power supply or fan tray) has been removed before inserting a module in the same slot.

Follow this procedure to install a module in the router.

1. If you are installing a module in a slot which may have been configured for a different module type, remove the old configuration information by following these steps.
 - a. Use the **show running-config** command in config mode to determine the current configuration of the slot.

```
Brocade(config)# show running-config
Current configuration:
!
ver V5.0.0T163
module 1 ni-mlx-20-port-1g-copper
!
```

2 Installing a Brocade MLXe-8 router

This example shows that slot 1 has already been configured for a 20-port 1 Gbps copper interface module.

Enter the **no module slot-number module-type** command to remove the configuration from slot 1. Use the slot number and module type shown in the output from the **show running-config** command.

```
Brocade(config)# no module 1 ni-mlx-20-port-1g-copper
```

This example removes the configuration from slot 1, leaving it ready for a new module.

2. Put on the ESD wrist strap and ground yourself by inserting the plug into the ESD connector on the chassis.
3. Remove the module from the packaging.
4. Insert the module into the router slot, and slide the card along the card guide until the ejectors on either side of the module move close to the module front panel. Refer to [Figure 36](#).

NOTE

When inserting the module into the router, be sure that the faceplate does not overlap the faceplate of an adjacent module.

5. Rotate the ejectors until they are flush with the module faceplate. This action will fully seat the module in the backplane.
6. Tighten the screws at each end of the module faceplate by pushing them in and turning them clockwise. Complete the tightening process using the flat-blade screwdriver.
7. Enter the **write memory** command to ensure that the slot will be correctly configured for the new module after a reboot.

```
Brocade(config)# write memory  
Write startup-config done.
```

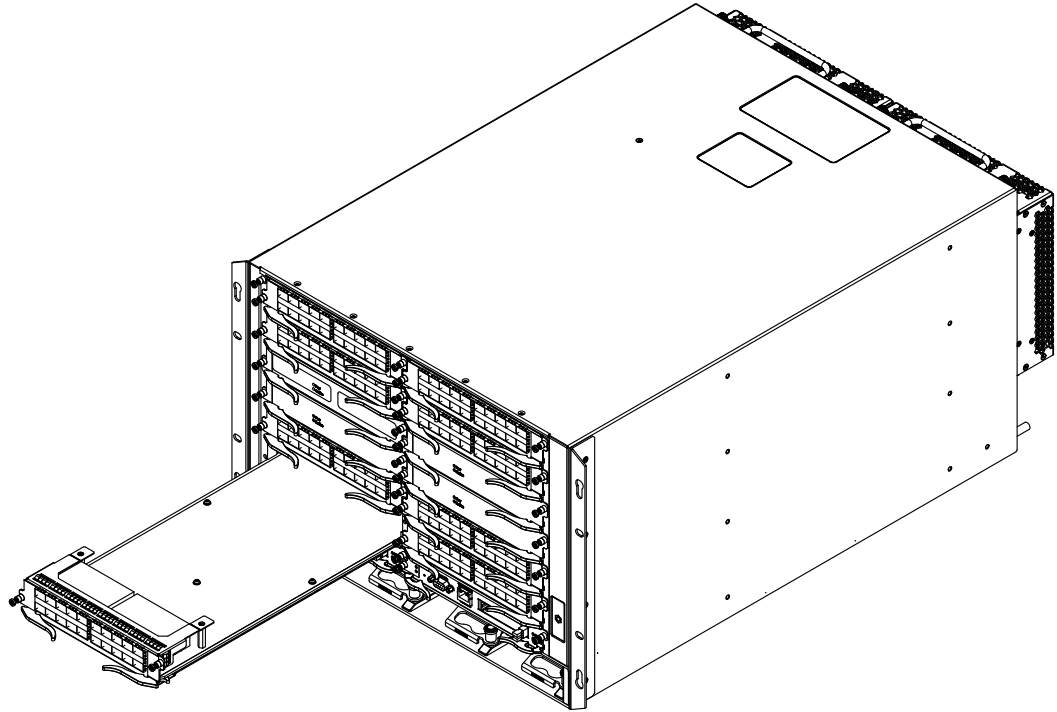
FIGURE 36 Installing a module in a Brocade MLXe-8 router

8. Rotate the ejectors flush with the module faceplate to fully seat the module in the backplane. Modules have a snug fit for maximum EMI protection.
9. Tighten the two screws on each side of the module faceplate by pushing them in and turning them clockwise. Complete the tightening process using a flat-blade screwdriver.

Installing power supplies in the Brocade MLXe-8 router

Follow these steps to install a power supply in the Brocade MLXe-8 router.

1. Remove the power supply slot blank.
2. Remove the power supply from the packaging.
3. Insert the power supply into the slot and slide it along the guides on each side of the slot. Refer to [Figure 37](#).

NOTE

Empty power supply slots must be covered with slot blanks.



CAUTION

Carefully follow the mechanical guides on each side of the power supply slot and make sure the power supply is properly inserted in the guides. Never insert the power supply upside down.

FIGURE 37 Installing a power supply in a Brocade MLXe-8 router

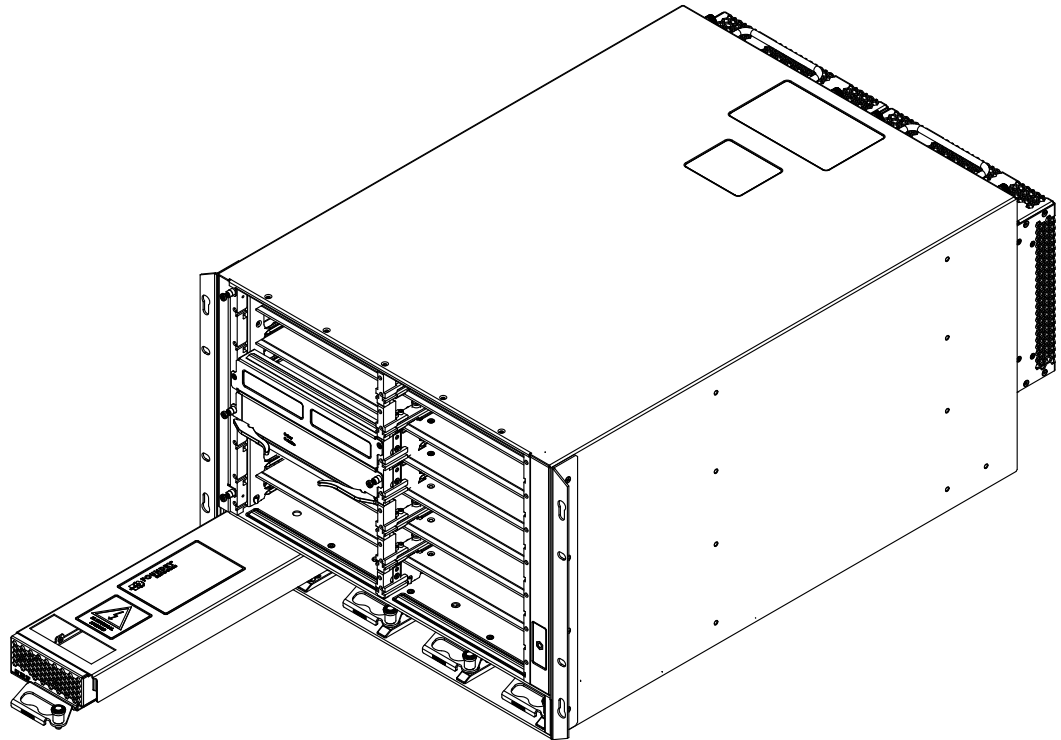

4. Push the power supply front panel into the router until it engages the backplane connector, and the latch pin clicks into place.

For information about connecting power to the router, refer to [“Connecting AC power”](#) on page 64, or [“Connecting DC power”](#) on page 65.

Connecting AC power

AC power is supplied through the power cord that is connected to the AC power supply in the router.

NOTE

For the NEBS-compliant installation, AC power connections must use a surge protection device (SPD) to protect the AC power supplies from damage due to excessive power line surges.

Follow these steps to connect the AC power cord.

1. Locate the AC inlet on rear of chassis for the associated installed AC power supply.
2. Lift the cord-retainer and connect the AC power cord to the associated power supply AC inlet.
3. Snap the cord-retainer over the power plug to hold it in place.



DANGER

If the installation requires a different power cord than the one supplied with the router, make sure you use a power cord displaying the mark of the safety agency that defines the regulations for power cords in your country. The mark is your assurance that the power cord can be used safely with the router.

For information about powering on the system, refer to [“Activating the power source”](#) on page 124.

Connecting DC power

You can provide DC power for the router by installing a DC-to-DC power supply. The DC-to-DC supply converts 48V-DC input from a power source to 12V-DC for your router.



DANGER

The procedure in this section is for qualified service personnel.

NOTE

Because there are multiple power supply vendors, the LED layout on your DC power supply may differ from what is shown in [Figure 38](#). However, the LED functions are identical.

Follow these steps to connect a DC power source.

1. Use a #1 Phillips screwdriver to remove the two screws that hold the transparent cover over the power supply lugs, as shown in [Figure 38](#).

FIGURE 38 The Brocade MLXe-8 DC power supply

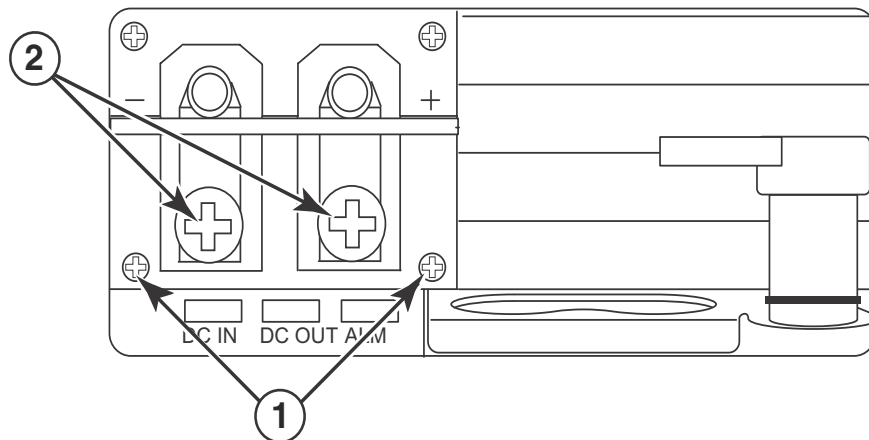

1. Screws holding transparent cover 2. Power lug screws
2. Use a #2 Phillips screwdriver to remove the power lugs.
3. Crimp #8 AWG power supply wire into the power lugs and reconnect the lugs to the power supply unit. Refer to [Figure 39](#).



CAUTION

For the NEBS-compliant installation of Brocade MLXe-4, Brocade MLXe-8, and Brocade MLXe-16 routers with AC and DC systems, use a ground wire of at least 6 American Wire Gauge (AWG). The ground wire should have an agency-approved crimped connector (provided with the device) attached to one end, with the other end attached to building ground. The connector must be

crimped with the proper tool, allowing it to be connected to both ground screws on the enclosure. Before crimping the ground wire into the provided ground lug, ensure the bare copper wire has been cleaned and antioxidant is applied to the bare wire.



CAUTION

For the NEBS-compliant installation of Brocade MLXe-32, routers with AC and DC systems, use a ground wire of at least 2 American Wire Gauge (AWG). The ground wire should have an agency-approved crimped connector (provided with the device) attached to one end, with the other end attached to building ground. The connector must be crimped with the proper tool, allowing it to be connected to both ground screws on the enclosure. Before crimping the ground wire into the provided ground lug, ensure the bare copper wire has been cleaned and antioxidant is applied to the bare wire.



CAUTION

To ensure adequate bonding when attaching the ground lug, a minimum of 20 PSI of torque is required to be applied to the mounting hardware used to attach the ground lug.

FIGURE 39 Crimping the power supply wire in the lug

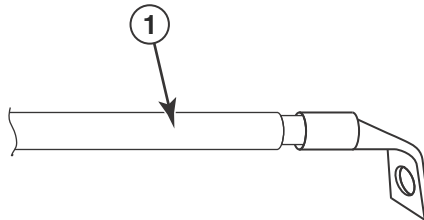

1. AWG power supply wire:
#8 AWG power supply wire for 1200W power supplies
#6 AWG power supply wire for 1800W power supplies
4. Connect the -48V cable to the negative terminal and the 0V cable to the positive terminal.

NOTE

DC return must be isolated from the router ground (DC-I) when connecting to DC power supplies.

5. Replace the transparent cover.

This equipment installation must meet NEC/CEC code requirements. Consult local authorities for regulations.

Final steps

Complete these final steps in the order listed:

- [“Attaching a management station”](#)
- [“Activating the power source”](#)
- [“Verifying proper operation”](#)

Installing a Brocade MLXe-16 router

The following sections describe how to install a Brocade MLXe-16 router.

NOTE

Illustrations may differ slightly from the actual equipment.

Preparing the installation site

Before installing the router, plan the location and orientation relative to other devices and equipment. For cooling purposes, allow a minimum of six inches of space between the sides, front, and the back of the router and walls or other obstructions. If you are installing the router in a perforated enclosure, the perforations must cover at least 60 percent of the surface.

Ensure that the proper power and network cabling is installed at the site. For information about cabling, refer to [“Installing power supplies in a Brocade MLXe-16 router”](#) on page 73, and [“Attaching a management station”](#) on page 123.

NOTE

This equipment is suitable for installation in a Network Telecommunication facility and where NEC requirements apply. Additionally, it may be installed in either a Common Bonding Network (CBN) or Isolated Bonding Network (IBN). It is not intended for Outside Plant (OSP) installations.

Unpacking a Brocade MLXe-16 router

The Brocade MLXe-16 router ships with the following items:

- Router chassis with switch fabric modules installed in the slots marked SF, and slot blanks installed in all empty module slots.
- Four AC or four DC power supplies
- Insertion or extraction tool for use with RJ45 and fiber-optic connectors.

If any of these items are missing, contact the place of purchase.

Remove your Brocade MLXe-16 router from the shipping carton. Save the shipping carton and packing materials in case you need to move or ship the router at a later time.

Lifting guidelines for Brocade MLXe-16 routers



DANGER

A fully-populated Brocade MLXe-16 router is heavy. TWO PEOPLE ARE REQUIRED WHEN LIFTING, HANDLING, OR MOUNTING THESE DEVICES.

Follow these guidelines for lifting and moving your Brocade MLXe-16 router:

2 Installing a Brocade MLXe-16 router

- Before lifting or moving the router, disconnect all external cables.
- Do not attempt to lift a fully configured router by yourself. Use two people to lift the router.
- It is recommended that you remove router components before installing the router in a rack.

Installing a Brocade MLXe-16 router in a rack



DANGER

Make sure the rack or cabinet housing the router is adequately secured to prevent it from becoming unstable or falling over.



DANGER

Mount the routers you install in a rack or cabinet as low as possible. Place the heaviest router at the bottom and progressively place lighter routers above.

You can install your router in a standard rack in either a front- or mid-mount position using the factory-installed mounting brackets. For a mid-mount configuration, simply remove the mounting brackets from the front edges of the device and re-attach them using the pre-drilled holes in the center sides of the device.

You can install up to three Brocade MLXe-16 routers in a standard 19-inch (EIA310-D) rack.

If you are installing your Brocade MLXe-16 router in a cabinet or 4-post rack, refer to [“Installing a Brocade MLXe-16 router in a cabinet or 4-post rack”](#) on page 82.

Front- or mid-mount in a standard rack

Follow these steps to mount a Brocade MLXe-16 router in a rack.

You will need to provide standard #12-24 pan-head screws to mount each router in a rack. You will need a Phillips screwdriver to perform this task.

NOTE

When connecting the device to the rack frame, use thread-forming screws and paint-piercing washers.

1. Determine the position of each router in the rack. For example, place routers with the fewest modules near the top of the rack, routers with more modules near the middle of the rack, and fully populated routers near the bottom of the rack.
2. Position four mounting screws for each router using the spacing of the keyhole slots (the ones with the narrow portion pointing up) on the mounting brackets as a guide, as shown in [Figure 40](#). When tightening the mounting screws, leave approximately 1/4 inch of clearance between the back of the screw head and the rack posts.

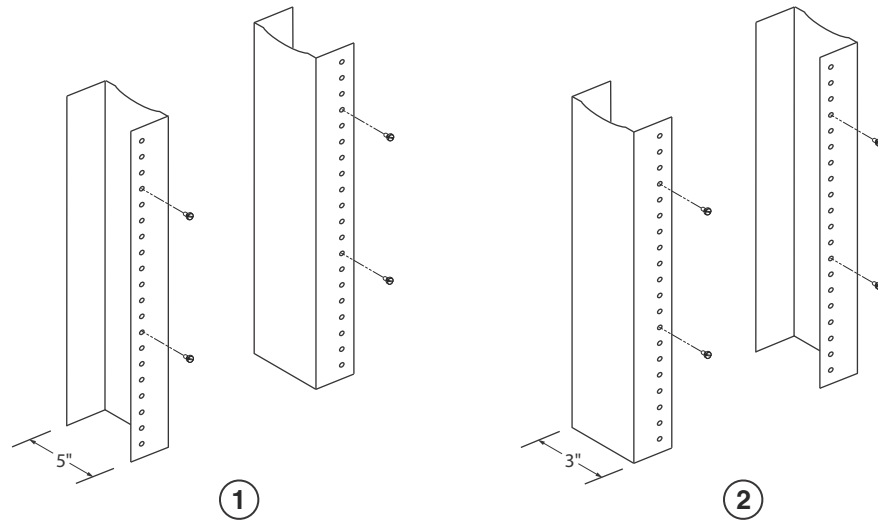
FIGURE 40 Positioning the mounting screws in the rack posts

1 Unequal flange equipment rack

2 Network equipment rack

- Starting with the router that will be in the lowest position in the rack, mount the router in the rack as shown in [Figure 41](#). With two or more people lifting the router, slip the wide portion of each keyhole slot over the corresponding mounting screw in the rack post.

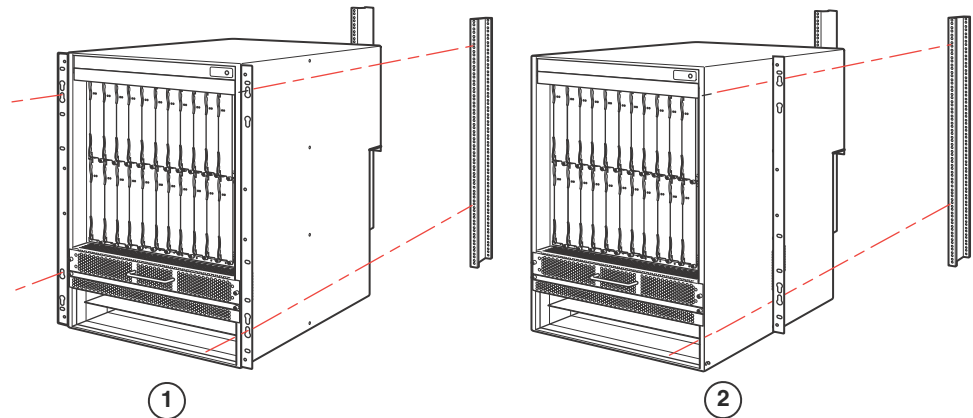
FIGURE 41 Mounting the Brocade MLXe-16 router in a rack

1 Front-mount configuration

2 Mid-mount configuration

- Slide the router down so that the mounting screw heads are in the narrow portion of the keyhole slots.
- Tighten the screws to secure the router in place. For extra support, use additional screws.

NOTE

For better grounding of the router to the rack, attach the router using star washers. You should also use star washers with any single-hole grounding lugs to keep the lugs from rotating.

NOTE

When making the primary ground connection, use a star washer to prevent lug rotation.

Repeat step 2 through step 5 to mount each router in the rack.

Installing modules in a Brocade MLXe 16-slot router

The Brocade MLXe-16 router ships with the required switch fabric modules installed.

The installation sequence for multiple modules is important to ensure proper fit. Always fill the bottom slots in the Brocade MLXe-16 router first. Begin by filling the slots from the left side of the router, and work towards the right side. Refer to [Figure 3](#) on page 5 for slot locations.

NOTE

Installation instructions are identical for interface, management, and switch fabric modules. However, there are specific requirements and installation instructions for the following devices:

For installing NI-MLX-10x8G and NI-MLX-1Gx48-T-A modules in the 16-slot router., refer to [“Installing modules in a Brocade MLXe 16-slot router”](#) on page 70.

For installing 2x100GbE interface modules, refer to [“Installing 2x100GbE interface modules in Brocade MLXe routers”](#) on page 43.

For instructions about installing BR-MLX-10Gx24-DM interface modules, refer to [“Installing BR-MLX-10Gx24-DM interface modules in Brocade MLXe routers”](#) on page 46.



DANGER

The intra-building ports of the equipment or subassembly are suitable for connection to intra-building or unexposed wiring or cabling only. The intra-building ports of the equipment or subassembly MUST NOT be metallically connected to interfaces that connect to the outside plant (OSP) or its wiring. These ports are designed for use as intra-building interfaces only (Type 2 or Type 4 ports as described in GR-1089-CORE, Issue 5) and require isolation from the exposed OSP cabling. The addition of Primary Protectors is not sufficient protection to connect these interfaces metallically to OSP wiring.

[Table 21](#) provides the router slot numbers into which you must install the modules. Markings for the router slots appear at the base of the slots.

TABLE 21 Brocade MLXe-16 module slot designations

Module	Slot number
Management modules	Active module – M1 (upper). Redundant module – M2 (lower).
Interface modules	1 – 16
Switch Fabric modules	SF1 – SF4

NOTE

If you are installing a redundant management module, refer to the chapter titled “Using a Redundant Management Module” in the *Brocade MLX Series and Brocade NetIron Family Configuration Guide* for information about how the redundant module works, optional software configurations that you can perform, and how to manage the redundancy feature.

NOTE

Brocade MLXe modules are dedicated, which means that you must install them in Brocade MLXe routers only. If you install a Brocade MLXe module in another Brocade router or install a module intended for another Brocade router in a Brocade MLXe router, the router and module may not function properly.

Although management modules are designed to be hot-swappable, you must upgrade the software on all interface modules and management modules to the appropriate software release before installing them. For more information on the appropriate software release, refer to the Hardware Installation Notes that shipped with the management module.

For information about how to disable and re-enable power to interface modules, see [“Disabling and re-enabling power to interface modules”](#) on page 151

Before installing modules in the Brocade MLXe-16 router, have the following items available:

- A large flat-blade screwdriver.
- A new or replacement interface module, which you can order from Brocade
- An ESD wrist strap with a plug to attach to the ESD connector on the router chassis.

**DANGER**

For safety reasons, the ESD wrist strap should contain a 1 megohm series resistor.

**CAUTION**

Use of a power screwdriver may twist the heads from the screws and is not recommended.

**CAUTION**

If you do not install a module in a slot, you must keep the slot blank in place. If you operate the router with an uncovered slot, the system may overheat. Tighten the screws that secure the slot blanks so that they remain in place when removing adjacent panels or modules.

Reset fan speed to auto

For Brocade MLXe 16-slot routers, if you insert a module into a slot where the fan speed for a previous module was manually configured, you will need to change the fan speed back to auto. For example, if the fan speed was manually configured to “slow”, and you are installing a module that requires more cooling power, the “slow” setting will cause the module to overheat. To configure the fan speed to auto, enter the following command:

```
Brocade# set-fan-speed auto
```

The Brocade MLXe-16 router ships with slot blanks installed in all empty module slots. The slot blanks help ensure proper airflow inside the router. You must remove the slot blank to install a module in a slot.

Although the slot blanks differ in size, the procedure for removing them is identical. You will need a flat-blade screwdriver to perform this task.

Follow these steps to remove a slot blank.

2 Installing a Brocade MLXe-16 router

1. Loosen the screws on either end of the slot blank by hand or with a flat-blade screwdriver.
2. Pull the slot blank out of the router and store it in a safe place for future use.



CAUTION

If you are hot-swapping a module, allow a minimum of two seconds after a module (or power supply or fan tray) has been removed before inserting a module in the same slot.

Follow this procedure to install modules in the router.

1. If you are installing a module in a slot which may have been previously configured for a different module type, remove the old configuration information using this procedure:

- a. Use the **show running-config** command in config mode to determine the current configuration of the slot.

```
Brocade-16(config)# show running-config
Current configuration:
!
ver V5.0.0T163
module 1 ni-mlx-20-port-1g-copper
!
```

This example shows that slot 1 is currently configured for a 20-port 1 Gbps copper interface module.

- b. With the module designation from **show running-config** command output, use the **no module slot-number module-type** command to remove the configuration from slot 1.

```
Brocade-16(config)# no module 1 ni-mlx-20-port-1g-copper
```

This command removes the configuration from slot 1, leaving it ready for a new module.

2. Put on the ESD wrist strap and ground yourself by inserting the plug into the ESD connector on the chassis.
3. Remove the module from the packaging.
4. Insert the module into the slot, and slide the module along the card guide until the ejectors on either side of the module rotate towards the module front panel.

NOTE

When inserting a module in the router, make sure that the module faceplate does not overlap the faceplate of an adjacent module.

5. Rotate the ejectors flush with the module faceplate. This action will fully seat the module in the backplane.
6. Tighten the two screws on the module faceplate by pushing them in and turning them clockwise. Complete the tightening process using the flat-blade screwdriver.
7. Enter the **write memory** command to ensure that the slot will be correctly configured for the new module after a reboot.

```
Brocade(config)# write memory
Write startup-config done.
```

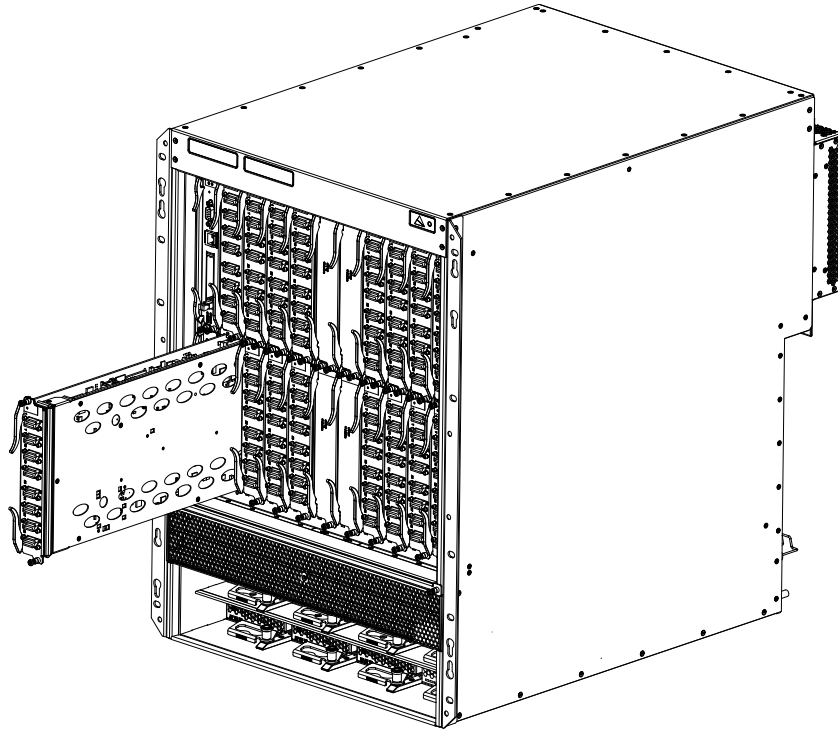
FIGURE 42 Installing a module in a Brocade MLXe-16 router

Installing power supplies in a Brocade MLXe-16 router



DANGER

High Touch Current. Earth connection is essential before connecting supply.

Follow these steps to install a power supply in a Brocade MLXe-16 router.

1. Remove the power supply slot blank.
2. Remove the power supply from the packaging.
3. Insert the power supply into the slot, using the guides on either side of the slot. Refer to [Figure 43](#).

FIGURE 43 Installing a power supply in a Brocade MLXe-16 router

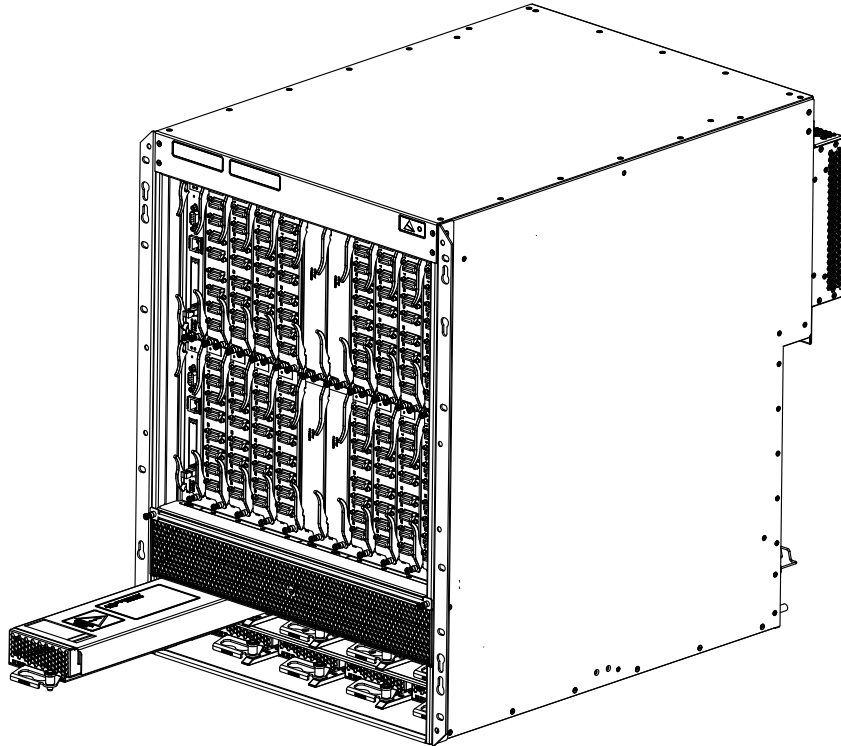

CAUTION

Carefully follow the mechanical guides on each side of the power supply slot and make sure the power supply is properly inserted in the guides. Never insert the power supply upside down.

4. Push the power supply front panel toward the back of the router. This action causes the power supply connector to engage the backplane connector.

NOTE

Do not overtighten screws when installing power supplies.

5. For information about connecting power to the router, refer to [“Connecting AC power”](#).
6. For information about powering on the system, refer to [“Activating the power source”](#) on page 124.

Connecting AC power

NOTE

For the NEBS-compliant installation, AC power connections must use a surge protection device (SPD) to protect the AC power supplies from damage due to excessive power line surges.

AC power is supplied through a power cord connected to the power supply in the Brocade MLXe-16 router.

Follow these steps to connect AC power:

1. Locate the power supply AC inlet at the bottom rear of chassis for the associated installed power supply.
2. Lift the cord retainer and connect an AC power cord to the associated power supply AC inlet.
3. Snap the cord retainer over the power plug to hold it in place.



DANGER

If the installation requires a different power cord than the one supplied with the router, make sure you use a power cord displaying the mark of the safety agency that defines the regulations for power cords in your country. The mark is your assurance that the power cord can be used safely with the router.

4. For information about powering on the system, refer to “[Activating the power source](#)” on page 124.

Connecting DC power

You can supply DC power to the Brocade MLXe-16 router using a DC-to-DC power supply. DC power must be supplied at 48 V and 30 A minimum. The DC-to-DC supply provides the DC power to the router at 12 V and 100 A.



DANGER

The procedure in this section is for qualified service personnel.

Follow these steps to connect a DC power source.

1. Use a #1 Phillips screwdriver to remove the two screws that secure the plastic cover over the power supply lugs, then remove the cover, as shown in [Figure 44](#).

FIGURE 44 Cover screws and DC power lugs

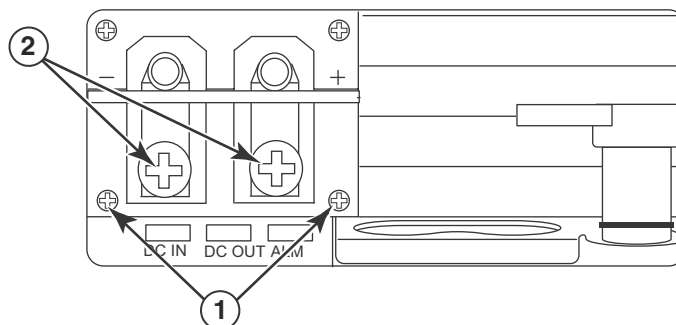

1. Transparent cover screws
 2. Power lugs
2. Use a #2 Phillips head screwdriver to remove the power lugs.
 3. Crimp #8 AWG power supply wire into the power lugs and reconnect the power lugs to the power supply unit. Refer to [Figure 45](#).



CAUTION

For the NEBS-compliant installation of Brocade MLXe-4, Brocade MLXe-8, and Brocade MLXe-16 routers with AC and DC systems, use a ground wire of at least 6 American Wire Gauge (AWG). The ground wire should have an agency-approved crimped connector (provided with the device) attached to one end, with the other end attached to building ground. The connector must be crimped with the proper tool, allowing it to be connected to both ground screws on the enclosure. Before crimping the ground wire into the provided ground lug, ensure the bare copper wire has been cleaned and antioxidant is applied to the bare wire.



CAUTION

For the NEBS-compliant installation of Brocade MLXe-32, routers with AC and DC systems, use a ground wire of at least 2 American Wire Gauge (AWG). The ground wire should have an agency-approved crimped connector (provided with the device) attached to one end, with the other end attached to building ground. The connector must be crimped with the proper tool, allowing it to be connected to both ground screws on the enclosure. Before crimping the ground wire into the provided ground lug, ensure the bare copper wire has been cleaned and antioxidant is applied to the bare wire.



CAUTION

To ensure adequate bonding when attaching the ground lug, a minimum of 20 PSI of torque is required to be applied to the mounting hardware used to attach the ground lug.

FIGURE 45 Crimping the power supply wire in the power lug

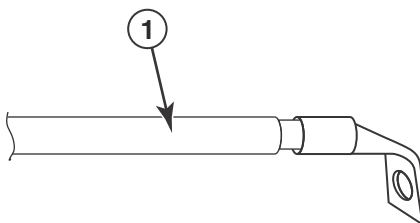

1. AWG power supply wire:
#8 AWG power supply wire for 1200W power supplies
#6 AWG power supply wire for 1800W power supplies
4. Connect the -48V cable to the negative terminal and the 0V cable to the positive terminal on the power supply.

NOTE

DC return must be isolated from the router ground (DC-I) when connecting to the power supply.

5. Replace the transparent cover.

This equipment installation must meet NEC/CEC code requirements. Consult local authorities for regulations.

Final steps

Complete these steps in the order listed:

- [“Attaching a management station”](#)
- [“Activating the power source”](#)
- [“Verifying proper operation”](#)

Mounting Brocade MLXe-4, -8, or -16 routers in a 4-post rack or cabinet

Cabinet or 4-Post Rack Mount Kit contents

You can mount Brocade MLXe routers in a cabinet or 4-post rack using the optional cabinet/4-post rack mount kits available from Brocade. [Table 22](#) lists these kits, and their contents.

TABLE 22 Cabinet/4-Post Rack Mount Kits for Brocade MLXe-4, MLXe-8, and MLXe-16 routers

Contents for RMK-CAB-MLXE-4	Contents for RMK-CAB-MLXE-8	Contents for RMK-CAB-MLXE-16
Front bracket left A (1)	Front bracket left A (1)	Front bracket left A (1)
Front bracket right B (1)	Front bracket right B (1)	Front bracket right B (1)
Left side plate A (1)	Left side plate A (1)	Left side plate A (1)
Right side plate (B 1)	Right side plate B (1)	Right side plate B (1)
2U shelf assembly (1)	2U shelf assembly (1)	Chassis alignment rail ((1)
Adjustable top rail (1)	Adjustable top rail (1)	Air block shelf (1)
Rail extender for top rail, 27-29" (1)	Rail extender for top rail, 27-29" (1)	Phillips flat-head screws, 6-32x1/4" (10)
Rail extender for top rail, 29-31" (1)	Rail extender for top rail, 29-31" (1)	Snap plastic rivets (12)
Thermal duct (1)	Thermal duct (1)	Right transport bracket, 27-29" (1)
Right transport bracket, 27-29" (1)	Right transport bracket, 27-29" (1)	Left transport bracket, 27-29" (1)
Left transport bracket, 27-29" (1)	Left transport bracket, 27-29" (1)	Right transport bracket, 29-31" (1)
Right transport bracket, 29-31" (1)	Right transport bracket, 29-31" (1)	Left transport bracket, 29-31" (1)
Left transport bracket, 29-31" (1)	Left transport bracket, 29-31" (1)	Alignment washers (4)
Alignment washers (4)	Alignment washers (4)	Phillips pan-head screws, 10-32x.63", square cone (30)
Phillips pan-head screws, 10-32x.63", square cone (30)	Phillips pan-head screws, 10-32x.63", square cone (30)	Floating clip nut, 10-32 (26)
Floating clip nut, 10-32 (26)	Floating clip nut, 10-32 (26)	Retainer nut, 10-32 (26)
Retainer nut, 10-32 (26)	Retainer nut, 10-32 (26)	Screws, 6-32, 1/4" Phillips flat-head, zinc, black (18)
Snap plastic rivets (12)	Snap plastic rivets (12)	Screws, 10-32, 1/4" Phillips flat-head, 100Deg, steel, black (16)
Phillips flat-head screws, 6-32x1/4" (10)	Phillips flat-head screws, 6-32x1/4" (10)	
Screws, 6-32, 1/4" Phillips flat-head, zinc, black (18)	Screws, 6-32, 1/4" Phillips flat-head, zinc, black (18)	
Screws, 10-32, 1/4" Phillips flat-head, 100Deg, steel, black (16)	Screws, 10-32, 1/4" Phillips flat-head, 100Deg, steel, black (16)	

Installing Brocade MLXe-4 and Brocade MLXe-8 routers in a cabinet or 4-post rack

This section describes how to install Brocade MLXe-4 or MLXe-8 routers in a cabinet or a 4-post rack using the RMK-CAB-MLXE-4 or RMK-CAB-MLXE-8 Cabinet/4-Post Rack Mount Kits.

2 Mounting Brocade MLXe-4, -8, or -16 routers in a 4-post rack or cabinet

To install a Brocade MLXe-16 router, use the RMK-CAB-MLXE-16 Cabinet/4-Post Rack Mount Kit, and refer to [“Installing a Brocade MLXe-16 router in a cabinet or 4-post rack”](#) on page 82.

NOTE

Because of the weight of fully loaded routers, it is recommended that you mount the router in a rack or cabinet before installing modules and power supplies.

You can install up to six Brocade MLXe-4 routers in a cabinet or rack using the RMK-CAB-MLXE-4 Cabinet/4-Post Rack Mount Kit. You can install up to four Brocade MLXe-8 routers in a cabinet or rack using the RMK-CAB-MLXE-8 Cabinet/4-Post Rack Mount Kit.

Many of the parts in these rack mount kits can be adjusted to accommodate a variety of cabinet and rack configurations.

Mounting your router in a cabinet or 4-post rack

Follow these steps to mount each Brocade MLXe-4 or Brocade MLXe-8 router in a cabinet or rack using the Cabinet/4-Post Rack Mount Kit, starting with the lowest device first.

The kits contain a variety of screws, nuts, clip nuts, and washers, for use in the following ways:

- Use floating clip nuts in cabinets or racks with round holes.
- Use retainer nuts in cabinets or racks with square holes.
- Use the square alignment washers for both round and square holes.

Select the appropriate hardware for your cabinet or rack configuration.

1. Place routers in the rack according to their weight. For example, mount the router with the fewest modules near the top of the rack, a router with more modules near the middle of the rack, and a fully populated router near the bottom of the rack.
2. Remove the factory-installed mounting brackets from the chassis.
3. Attach the front mounting brackets to the chassis using eight 6-32 flat head screws.

Brackets are marked with A or B. As you face the front of the cabinet or rack, A brackets must be installed on the left side, and B brackets are installed on the right side. Do not mix A and B brackets. Refer to [Figure 46](#). The process is identical for 4-slot and 8-slot routers.

FIGURE 46 Attach front mounting brackets to the router (MLXe-4 shown)

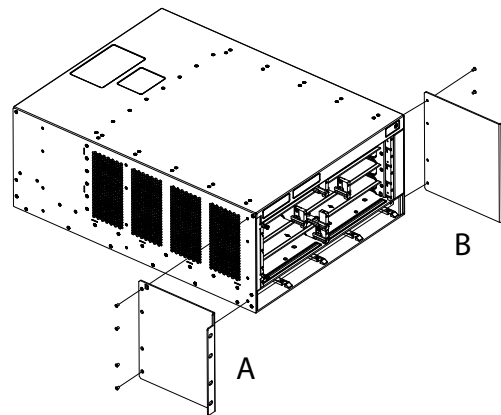

4. Attach the side plates to the rear of the router, using eight 6-32 flat-head screws. Refer to [Figure 47](#).

FIGURE 47 Attach side plates to the rear of the router (MLXe-4 shown)

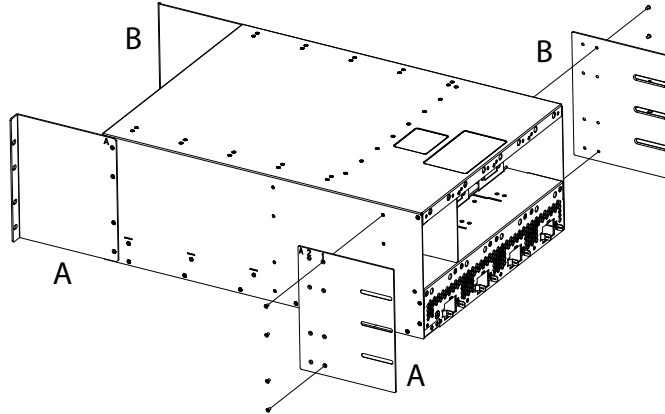

There are two sizes of side plates to accommodate cabinets or racks with depths of 27-28 inches, and depths of 29-31 inches. Be sure to select the side plate that is appropriate for your cabinet or rack.

5. The mounting shelf adjusts to accommodate racks with depths from 27 to 31 inches, for both 4-slot and 8-slot routers. Slide the adjustable rails to the proper depth for your installation, and install the mounting shelf to the rack rails using eight 10-32 screws. Refer to [Figure 48](#).

FIGURE 48 Install the mounting shelf in the rack

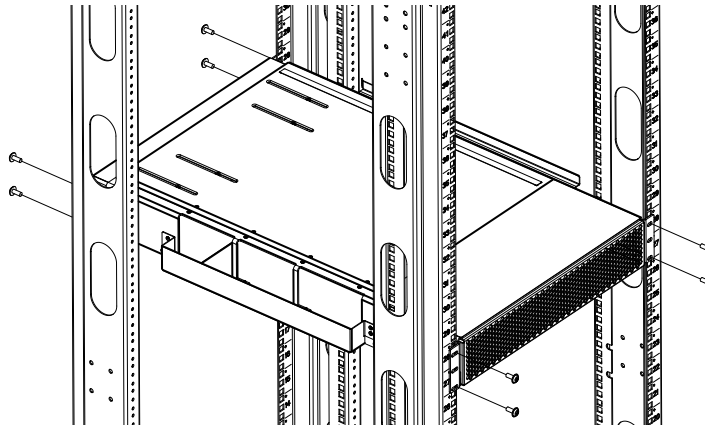

2 Mounting Brocade MLXe-4, -8, or -16 routers in a 4-post rack or cabinet

6. Install the side duct to the mounting shelf, using the tab and slot features at the base of the duct assembly. Refer to [Figure 49](#).

FIGURE 49 Install side air ducts to the mounting shelf (MLXe-4 and MLXe-8)

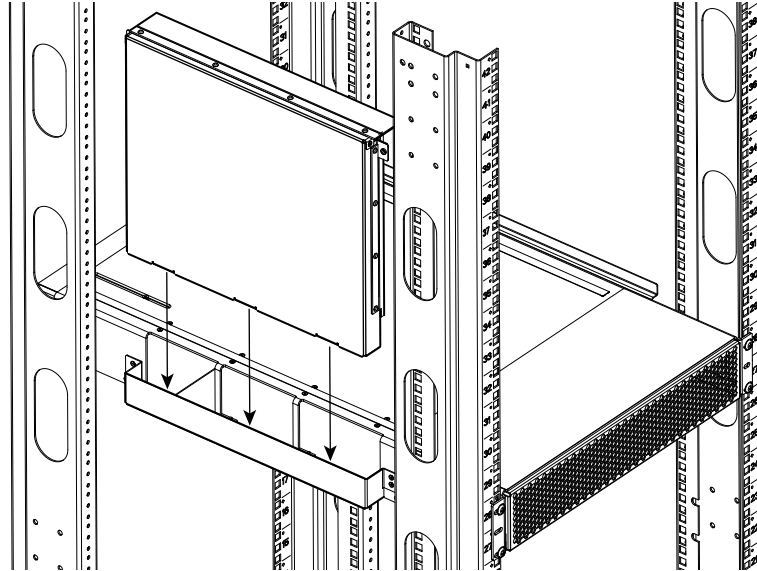

7. Select the rail extender that is appropriate for the depth of your cabinet or rack and attach it to the front of the top rail. Install the top rail to the cabinet or rack rails using four 10-32 screws. Attach the top rail to the duct assembly using two 6-32 flat-head screws. Refer to [Figure 50](#).

FIGURE 50 Install top rails to the rack

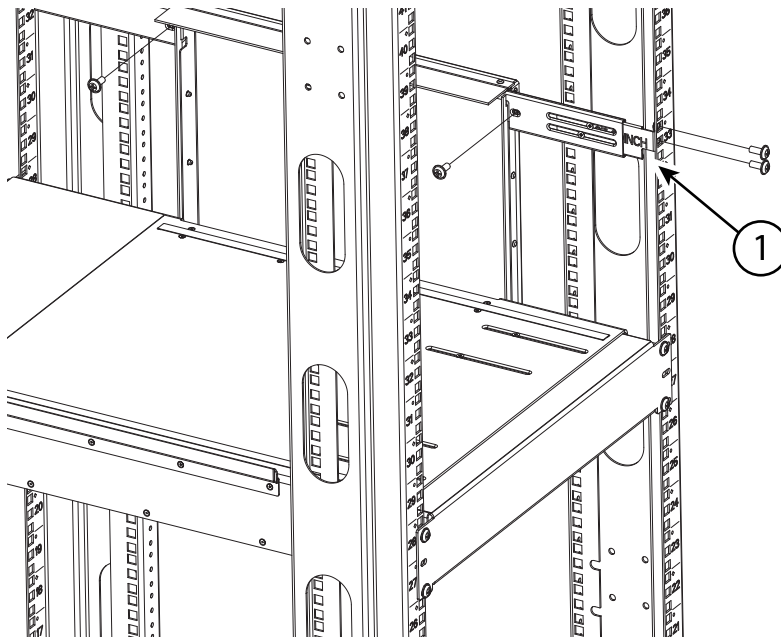

1. Rail extender

8. Install the router in the cabinet or rack. The router slides into the rack on top of the mounting shelf. Secure the router to the rack rails using eight 10-32 screws. Refer to [Figure 51](#) (MLXe-4 slot router shown).

FIGURE 51 Install the router on the mounting shelf

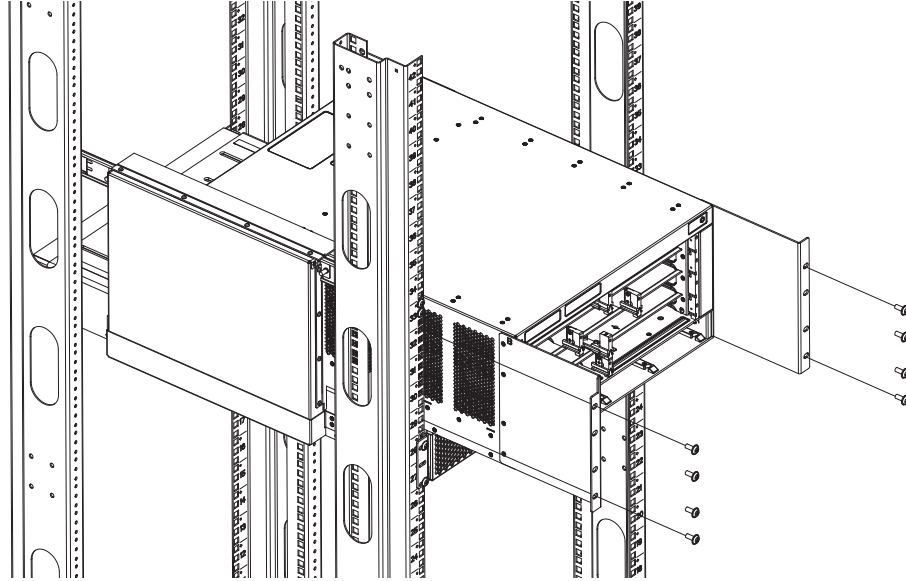

9. Install the transport brackets to the cabinet or rack rails and to the side plates on the router, using six 10-32 screws. Refer to [Figure 52](#).

NOTE

The transport brackets provide extra stability, and must be installed if you plan to ship the device while it is mounted in the cabinet or rack. Before you install the transport brackets, you must first remove any installed fans.

FIGURE 52 Attach transport brackets to router and to cabinet or rack

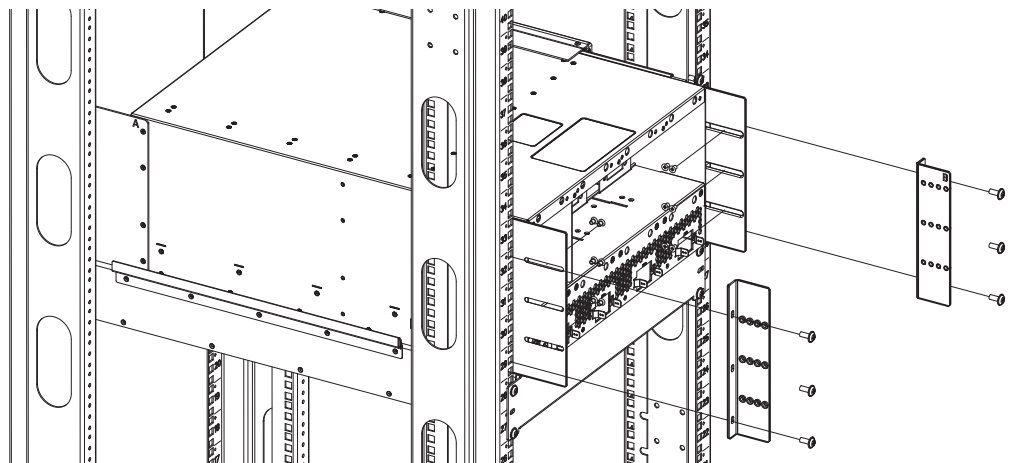

2 Mounting Brocade MLXe-4, -8, or -16 routers in a 4-post rack or cabinet

Installing a Brocade MLXe-16 router in a cabinet or 4-post rack

Using the Cabinet/4-Post Rack Mount Kit, you can install up to four Brocade MLXe-8 routers in a cabinet or rack.



DANGER

Make sure the rack or cabinet housing the router is adequately secured to prevent it from becoming unstable or falling over.



DANGER

Mount the routers you install in a rack or cabinet as low as possible. Place the heaviest router at the bottom and progressively place lighter routers above to prevent the rack or cabinet from becoming top-heavy and tipping over.

To install your Brocade MLXe-16 router in a cabinet or 4-post rack, perform the following steps.

1. Remove the factory-installed mounting brackets from the sides of the router.
2. Attach the cabinet mounting brackets to the front of the router using the 12 8-32 flat head screws. Refer to [Figure 53](#).

FIGURE 53 Attach the mounting brackets to the front of the router

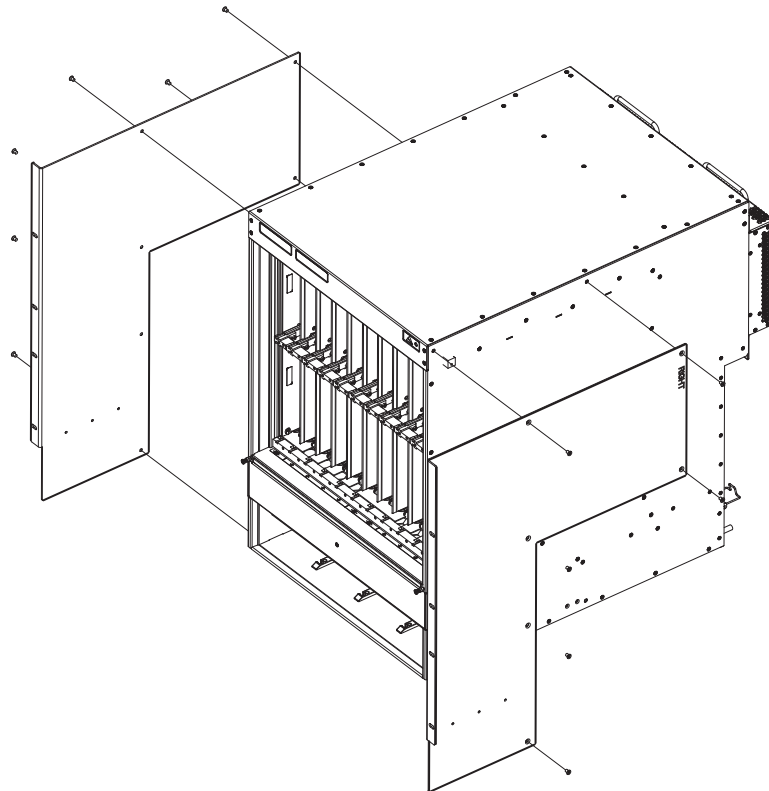

3. Attach the side plates to the router using 8 4-40 flat head screws. Refer to [Figure 54](#).

FIGURE 54 Attach the side plates to the rear sides of the device

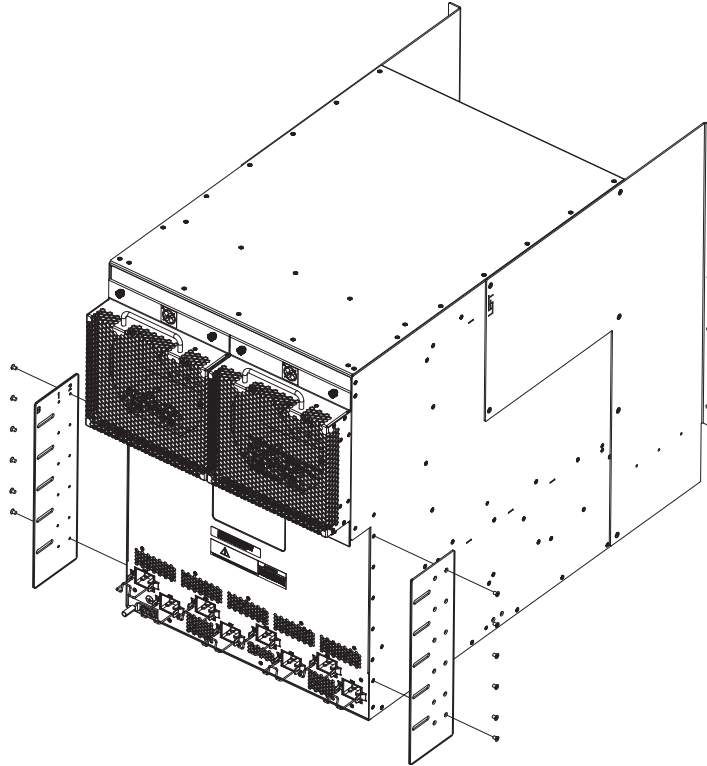

4. Attach the telescoping rails to the mounting posts in the cabinet or rack. Refer to [Figure 55](#),

FIGURE 55 Attach telescoping rails to cabinet or rack mounting posts (one rail shown)

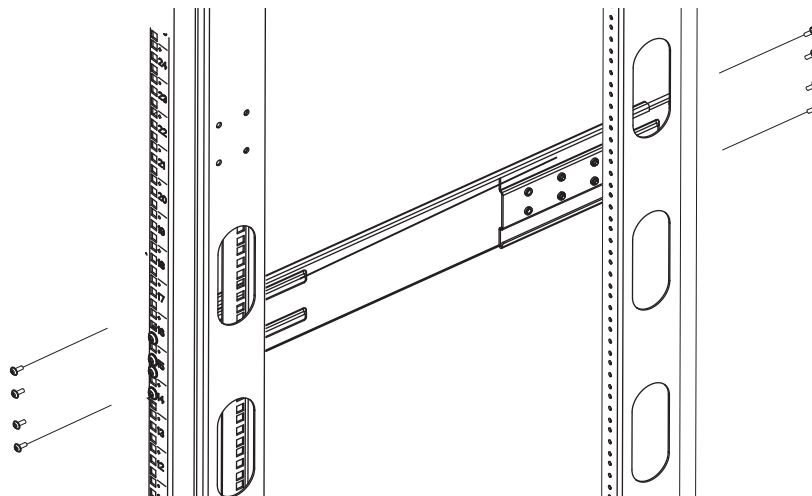

2 Mounting Brocade MLXe-4, -8, or -16 routers in a 4-post rack or cabinet

5. Install the router in the cabinet or rack using 8 10-32 screws. Refer to [Figure 56](#).

FIGURE 56 Install the router in the cabinet or rack

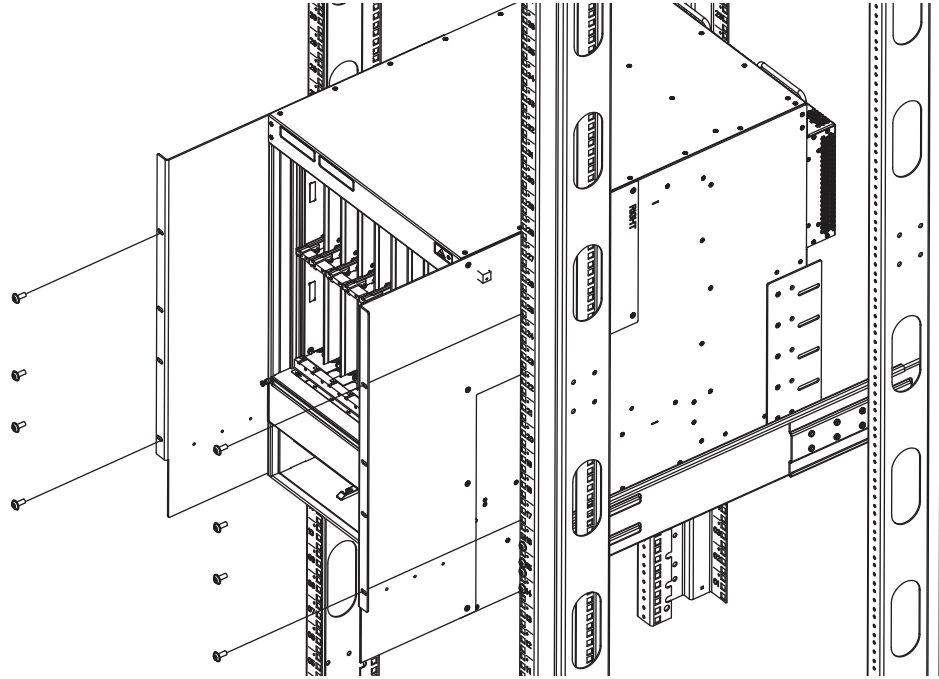

6. Secure the transport brackets to the rear of the router using 10 10-32 screws, and to the cabinet or rack mounting posts using 6 10-32 screws. Refer to [Figure 57](#).

NOTE

The transport brackets provide extra stability, and must be installed if you plan to ship the device while it is mounted in the cabinet or rack. Before you install the transport brackets, you must first remove any installed fans.

FIGURE 57 Secure transport brackets to the device and cabinet mounting posts

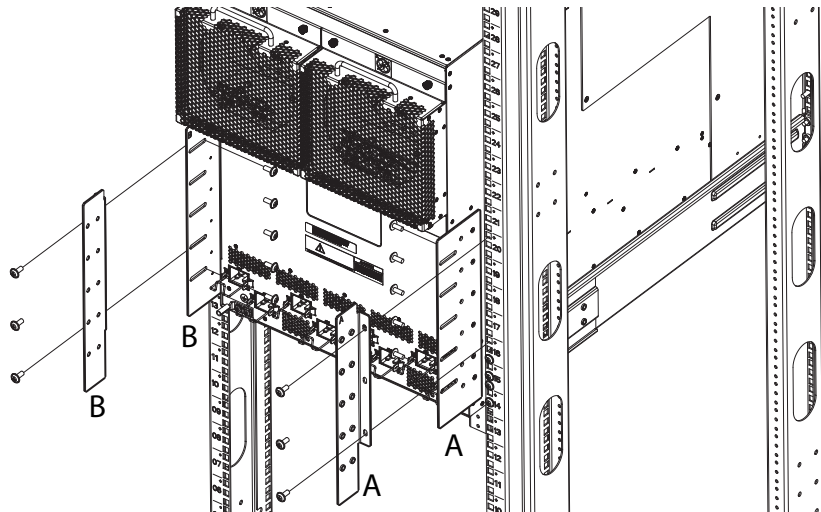

7. Attach the air block bracket to the front of the cabinet. Refer to [Figure 58](#).

FIGURE 58 Install the air block bracket

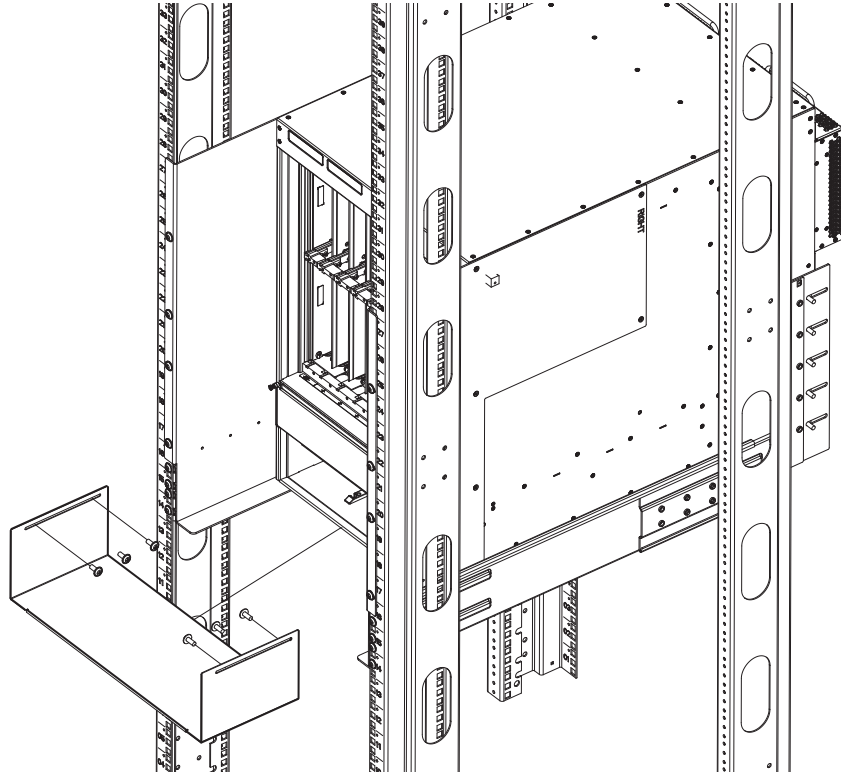

8. Attach the cable management comb. Refer to [Figure 59](#). For cable management instructions, refer to “[Brocade MLXe-32 cable management](#)” on page 108.

FIGURE 59 Attach the cable management comb

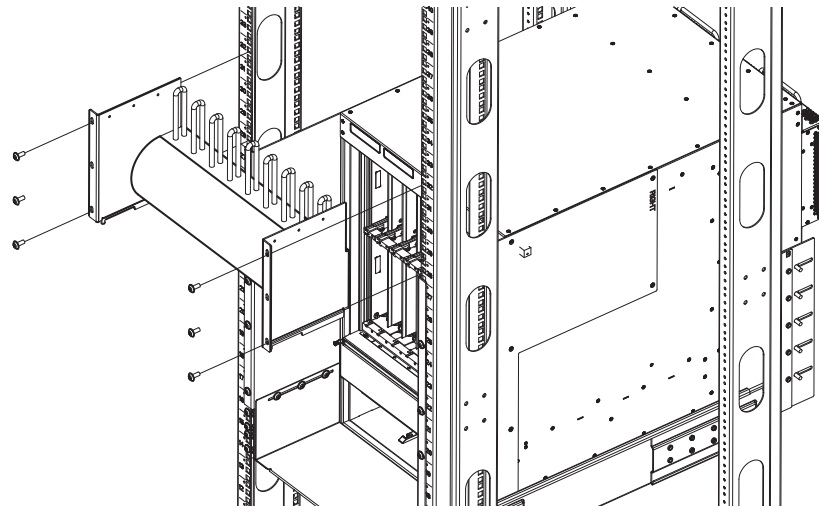

- Repeat steps 1 through 9 for each router you install in the cabinet.

Installing a Brocade MLXe-32 router

This section describes how to install a Brocade MLXe-32 router.

NOTE

Illustrations in this chapter may differ slightly from the actual equipment.

Preparing the installation site

Before installing the router, plan the location and orientation relative to other devices and equipment. For cooling purposes, allow a minimum of six inches of space between the sides, front, and the back of the router and walls or other obstructions. If a router is installed within a perforated enclosure, the perforations must cover at least 60 percent of the surface.

NOTE

This equipment is suitable for installation in a Network Telecommunication facility and where NEC requirements apply. Additionally, it may be installed in either a Common Bonding Network (CBN) or Isolated Bonding Network (IBN). It is not intended for Outside Plant (OSP) installations.

You will need to use a mechanical lift to move and install the router. Be sure to allow enough working room for the lift.

NOTE

Make sure your site provides 200-240 AC power.

Ensure that the proper power and network cabling is installed at the site.

For information on cabling, refer to [“Brocade MLXe-32 cable management”](#) on page 108, [“Installing power supplies in a Brocade MLXe-32 router”](#) on page 118, [“Attaching a management station”](#) on page 123.

Brocade MLXe-32 router shipping carton contents

The Brocade MLXe-32 router ships with the following items:

- Router chassis with the empty slots covered with upper and lower shipping panels. The router is housed in a wooden shipping crate that is strapped to a pallet.
- The appropriate number of interface modules, switch fabric modules, management modules, and power supplies (four AC or four DC) in separate shipping cartons.
- 32 slot blanks in separate shipping carton.
- Insertion or extraction tool for use with RJ45 and fiber-optic connectors.

If any of these items are missing, contact the place of purchase.

Unpacking your Brocade MLXe-32 router

You will need the following tools to remove your router from the shipping crate:

- A forklift or pallet jack with a minimum limit of 550 lbs to move the router crate on the pallet.
- A mechanical lift with a minimum 350 lb limit to move the router off the pallet. The ideal lift configuration is a counterweight base material lift with a metal lift plate installed in place of the forks. The metal plate should be no wider than 17 inches, so that it will fit between the rack mount rails.
- A strap to stabilize the router while you are moving it on the mechanical lift.
- A power drill with the following attachments:
 - Large Phillips screwdriver
 - Large flat-blade screwdriver
 - 7/16-inch socket wrench

The Brocade MLXe-32 router ships in a wooden crate bolted to a wooden platform that rests on a pallet. Follow these steps to uncrate the router.

1. The router shipping crate must be in the upright position with enough space to slide the crate off of the pallet.
2. Use a power drill with Phillips and large flat-blade screwdriver attachments to remove the bolts and screws that hold the front shipping crate panel in place, as shown in [Figure 60](#). Remove the front panel and set it aside.

FIGURE 60 Removing bolts and screws and the front panel of the shipping crate

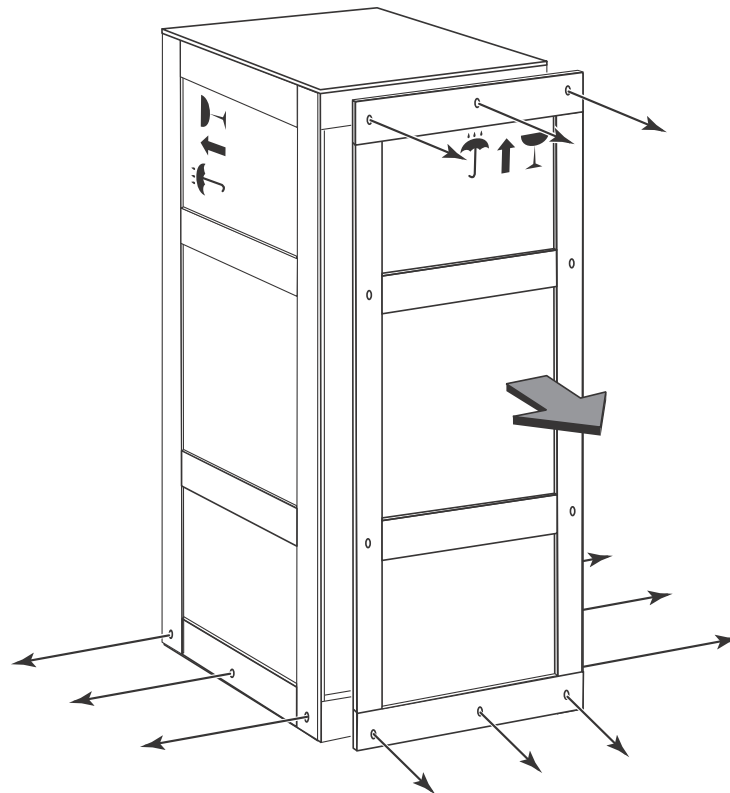

3. Remove the remaining bolts and screws that attach the bottom of the crate to the pallet.
4. Slide the sides, top, and back of the crate backwards as one unit until it clears the pallet.
5. Save the crate (including the shipping panel) in case the router needs to be shipped again.

Installing a Brocade MLXe-32 router in a rack



DANGER

Make sure the rack or cabinet housing the router is adequately secured to prevent it from becoming unstable or falling over.



DANGER

Mount the routers you install in a rack or cabinet as low as possible. Place the heaviest router at the bottom and progressively place lighter routers above.

Because of the weight of a fully loaded Brocade MLXe-32 router, it is recommended that you install the router in a rack before installing any modules and power supplies.

You can install one 32-slot router in a standard 19-inch 2-post or 4-post rack or open cabinet, in either a front-mount position or a mid-mount position. You must provide eight standard #12-24 pan-head screws to secure the router in the rack. You will need a #2 Phillips screwdriver to perform this task.

NOTE

Because of the weight of a fully-populated 32-slot chassis, it is not recommended that you install your 32-slot router in a 2-post rack or open cabinet. The preferred installation is in a 4-post rack or open cabinet. Refer to [“Installing your 32-slot router in a 4-post rack or open cabinet”](#) on page 95 for installation instructions

Installation requirements

Allow 1 to 2 hours to complete this procedure. Your installation site must meet the following requirements to ensure correct installation and operation:

- Provide 35 U of space in a 19 inch rack.
- Verify that the additional weight of the router does not exceed the weight limits for the rack or the floor.
- Ensure that an electrical branch circuit with the following characteristics is available:
 - Required voltage and frequency as indicated in the hardware reference manual.
 - Protection by a circuit breaker in accordance with local electrical codes.
 - Supply circuit, line fusing, and wire size that conform to the electrical rating on the router nameplate.
 - Grounded outlet compatible with the power cord and installed by a licensed electrician.

- Ensure that all equipment installed in the rack is grounded through a reliable branch circuit connection. Do not rely on a secondary connection to a branch circuit, such as a power strip.
- Ensure that the rack is mechanically secured to support the router model. Ensure that the airflow available at the inlet air vents does not exceed 40° Celsius (104° Fahrenheit).
- Only one 32-slot device can be mounted per rack, positioned as close to the bottom of the rack as possible.
- The empty device weighs approximately 362 lbs. You will need a mechanical device (such as a material lift), and at least two people to guide the device into place.
- Before you install the device, make sure that the rack is in a permanent location and is secured to the floor or wall of the building. The installation site must allow adequate clearance for airflow, installation, and maintenance.

Tool requirements and parts list

You will need the following tools to install a 32-slot device in any rack or cabinet.

- A forklift or pallet jack to move the router while it is on the pallet (500 lbs. minimum).
- Insertion-extraction tool for use with RJ45 and fiber-optic connectors
- A mechanical lift tool fitted with a lift plate (instead of forks) to move the device off the pallet and transport it to the rack. The lift should be rated for 500 lbs. minimum.
- A strap to secure and stabilize the device while it is being moved on the mechanical lift
- A power drill with the following attachments:
 - Large #2 Phillips screwdriver attachment
 - A 7/16 inch socket wrench attachment
 - Large 3/8 inch flat blade screwdriver attachment

Preparing the installation site

Before installation, plan the location and orientation of the device relative to other equipment in the rack. For cooling purposes, allow a minimum of six inches of space between the front and back of the device, and walls or other obstructions.

Because you will need to use a mechanical lift to move and install the device, make sure you allow enough space to operate the lift. You will also need at least two people to slide the router off the lift and into the rack.

Preliminary rack mount installation steps

Follow these initial steps to mount a 32-slot device in any rack or open cabinet. To install your device in a 2-post rack or open cabinet (not recommended), refer to [“Installing your 32-slot device in a 2-post rack or open cabinet”](#) on page 90. To install your device in a 4-post rack or open cabinet, refer to [“Installing your 32-slot router in a 4-post rack or open cabinet”](#) on page 95.

1. Ensure the rack is in a permanent location and is secured to the building. Ensure that the installation site allows adequate clearance for airflow, installation, and maintenance.
2. Move the pallet and router as close to the installation site as possible.
3. Remove the chassis from the shipping pallet.
4. Position the mechanical lift equipped with a lift plate as close to the front of the router as possible. Adjust the lift plate height so that it is even with the bottom of the router.

- Slide the router onto the lift plate.

**DANGER**

Four or more people are required to position the unpopulated router into the rack.

**DANGER**

Do not use the handles on the power supply units or fan modules to position the router.

- Secure the router to the mechanical lift with a strap to prevent tipping.
- Carefully position the router in front of the rack where it is to be installed.

NOTE

Make sure your site provides 200-240V power.

Installing your 32-slot device in a 2-post rack or open cabinet

NOTE

Because of the weight of a fully-populated 32-slot chassis, it is not recommended that you install your 32-slot router in a 2-post rack or open cabinet. The preferred installation is in a 4-post rack or open cabinet. Refer to [“Installing your 32-slot router in a 4-post rack or open cabinet”](#) on page 95 for installation instructions

You can install your 32-slot device in a 2-post rack or open cabinet in either a front-mount configuration or a mid-mount configuration using the factory-installed mounting brackets. For a mid-mount configuration, simply remove the factory-installed mounting brackets from the front edges of the device and re-attach them to the center sides of the device using the pre-drilled holes.

Once you have completed the preliminary installation preparations (refer to [“Preliminary rack mount installation steps”](#) on page 89), complete the following steps to install your router in a 2-post rack or cabinet.

- Unpack the Open Frame EIA 310-D Rack Mount Kit. Refer to [Table 23](#) and [Figure 61](#) for a list and illustration of the kit components.

[Table 23](#) lists the items that are included in your Open Frame EIA 310-D Rack Mount Kit.

TABLE 23 Open Frame EIA 310-D Rack Mount Kit contents

Part Number	Description	Quantity
42-1000452-01	Saddle	1
52-0000211-01	10-32 x 5/8 inch screws	14
52-1000141-01	12-24 x 1/2 inch screws	14
52-1000138-01	M6 x 12 mm screws	14

ATTENTION

Use the screws specified for the type of rack. Make sure you have the items listed above and shown in [Figure 61](#).

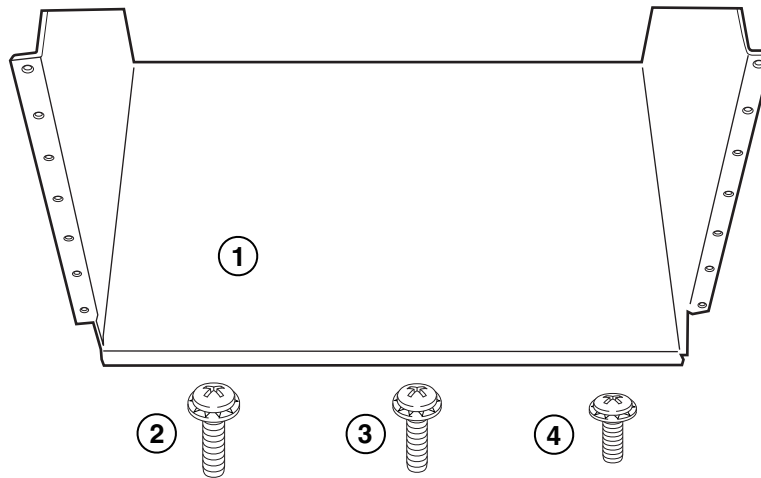
FIGURE 61 Open Frame EIA 310-D Rack Mount Kit contents

- 1 Saddle
 - 2 10-32 x 5/8 inch screw
 - 3 12-24 x 1/2 inch screw
 - 4 M6 x 12 mm screw
2. Allow 35U in the rack to accommodate the router. See [Figure 62](#) for alignment:
 - The saddle requires 1U of permanent space in the rack.
 - The router requires 33U of space in the rack, plus 1U temporary space above for installation.
 3. Align the holes in the saddle with the holes on the mounting posts and attach the saddle using a minimum of eight standard pan head screws that were provided in the kit, either #12-24, #10-32, or M6, as appropriated for your rack (four screws on each post, in the three top holes and one bottom hole). See [Figure 63](#).

NOTE

Additional screws may be used for more support.

2 Installing a Brocade MLXe-32 router

FIGURE 62 Align the saddle in the rack

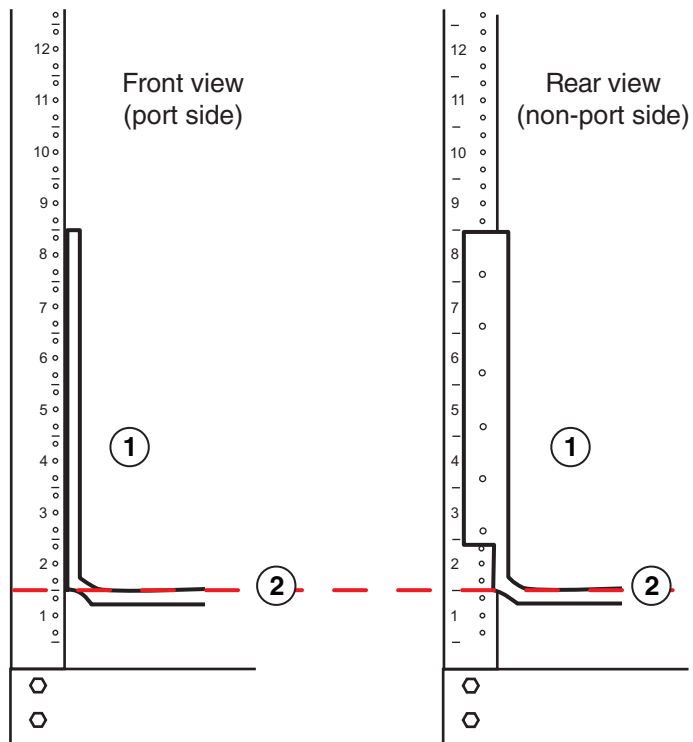

- 1 Saddle
- 2 Seat of saddle aligns with U marking on mounting posts as shown

FIGURE 63 Saddle installation

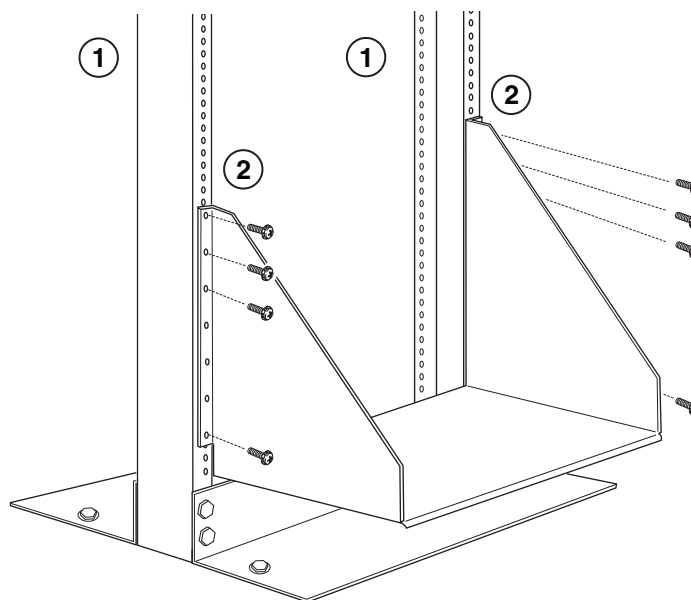

- Slide chassis onto the saddle
- 1 Front (port side) of rack mounting post
 - 2 Rear side of rack mounting post

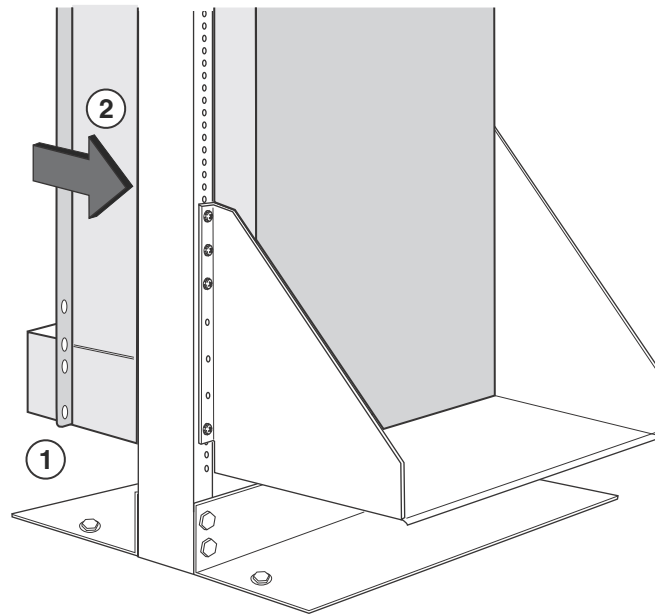
FIGURE 64 Slide the device into the rack

- 1 Align bottom of router slightly above the seat of the saddle using mechanical lift.
- 2 Using at least two people, slide router gently onto saddle and into the rack.
4. Use the provided standard #12-24, #10-32 or M6 pan head screws (dependent on the specifications of your rack) in each available hole on the rack mount bracket to attach the router to the rack mounting poles. See [Figure 65](#).
5. Visually inspect the alignment of the router. If the router is installed properly, the mounting screws on both sides rack should be aligned with the mounting screws on the opposite side and the router should be level.

FIGURE 65 Secure the router to the rack

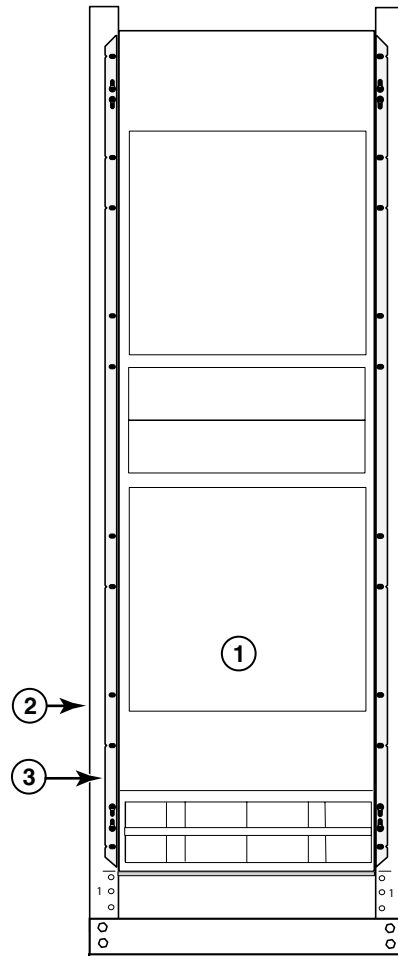

- 1 Router installed in open frame rack
 - 2 Rack mounting poles
 - 3 Router mounting brackets
6. Remove the strap securing the router to the mechanical lift.
 7. With two people in front and two people in back, slide the router into the rack.
 8. For a mid-mount, remove the factory-installed mounting brackets from the front edges of the device. Re-attach the mounting brackets to the center sides of the device using the pre-drilled holes in the device. For a front-mount, use the brackets as they were installed at the factory.
 9. If you are installing the router in a standard rack, install a mounting screw and a cage nut into each of the holes on the rack posts aligned with the threaded holes in the spacer bars.

NOTE

When connecting the chassis to the rack frame, use thread-forming screws and paint-piercing washers.

10. Visually inspect the alignment of the router. If the router is installed properly in the rack, the mounting screws on one side of the rack should align with the mounting screws on the opposite side and the router should be level. Add all remaining screws.

NOTE

For better grounding of the router to the rack, attach the router using star washers. You should also use star washers with any single-hole grounding lugs to keep the lugs from rotating.

Installing your 32-slot router in a 4-post rack or open cabinet

You can install Brocade MLX Series 32-slot routers in a 4-post rack or open cabinet using the optional 4-post rack mount kit available from Brocade. [Table 24](#) lists the contents of this kit.

TABLE 24 4-Post Rack Mount Kit contents

Part number	Description	Quantity
49-1000166-01	27-31" rail, left	1
49-1000167-01	27-31" rail, right	1
42-1000901-01	Rack mount bracket, left	1
42-1000902-01	Rack mount bracket, right	1
42-0200036-01	Washer, alignment	16
52-0000211-01	Screw, 10-32X.63"	16
52-0200270-01	Nut, floating clip 10-32	16
52-0000210-01	Nut, retainer, 10-32	16
52-1000136-01	Screw, 8-32X.375	10
52-1000138-01	Screw, M6X1.0X12	16

NOTE

Because of the weight of fully loaded 32-slot routers, it is recommended that you mount the router in the rack or cabinet before installing modules and power supplies.

You will need the following items to install your 32-slot router in a 4-post rack or open cabinet:

- A mechanical lift fitted with a lift plate (instead of forks) to move the device off the pallet and transport it to the rack. The lift should be rated for 500 lbs. minimum.
- A strap to secure and stabilize the device while it is being moved on the mechanical lift.
- Screws to attach the rails to your cabinet type. (These are usually provided with the cabinet or rack.)

**DANGER**

Four or more people are required to position the unpopulated router into the rack.

**DANGER**

Do not use the handles on the power supply units or fan modules to position the router.

2 Installing a Brocade MLXe-32 router

Before installation, plan the location and orientation of the device relative to other equipment in the rack. For cooling purposes, allow a minimum of six inches of space between the front and back of the device, and walls or other obstructions.

Because you will need to use a mechanical lift to move and install the device, make sure you allow enough space to operate the lift. You will also need at least two people to slide the router off the lift and into the rack.

Once you have completed the preliminary installation preparations (refer to [“Preliminary rack mount installation steps”](#) on page 89), follow these steps to mount your 32-slot router in a 4-post rack or open cabinet.

1. Remove the factory-installed mounting brackets from the router chassis.
2. Attach the front right and left mounting brackets to the chassis using 10 8-32 Phillips flat head screws (provided). Refer to [Figure 66](#).

FIGURE 66 Attach front right and left mounting brackets to the router chassis

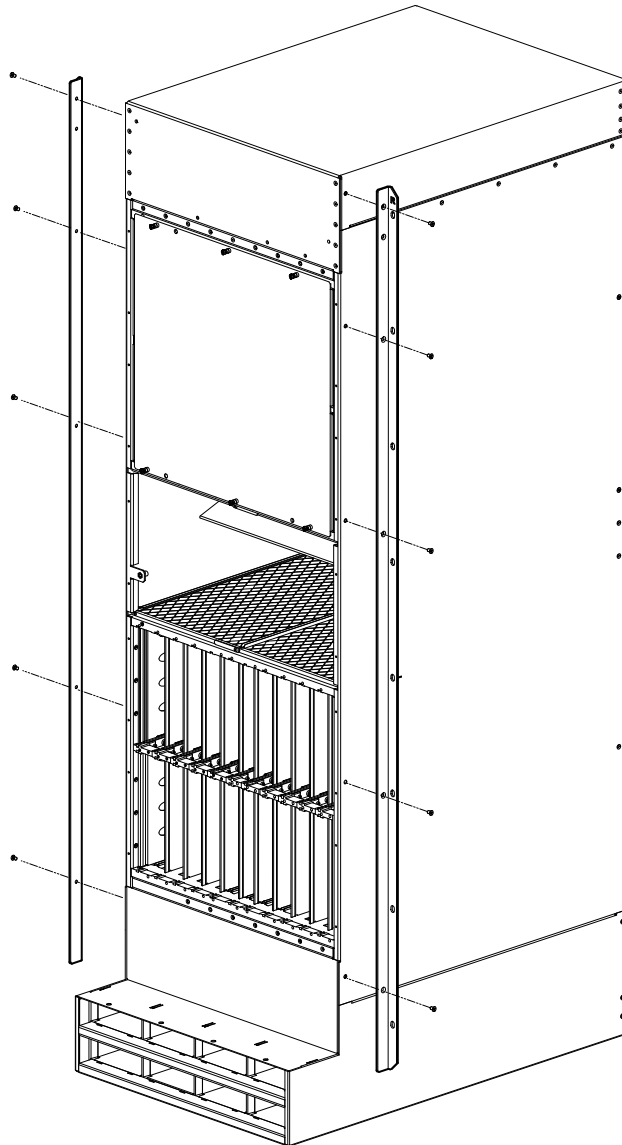

3. Adjust the telescoping rails to fit your rack. The rails can accommodate rack depths from 27 - 31 inches.
4. Attach the side rails to the front and back of the rack, using M6 screws. Refer to [Figure 67](#).

NOTE

The narrow telescoping ends of the side rails should be attached at the back of the rack.

FIGURE 67 Attach the telescoping side rails to the rack.

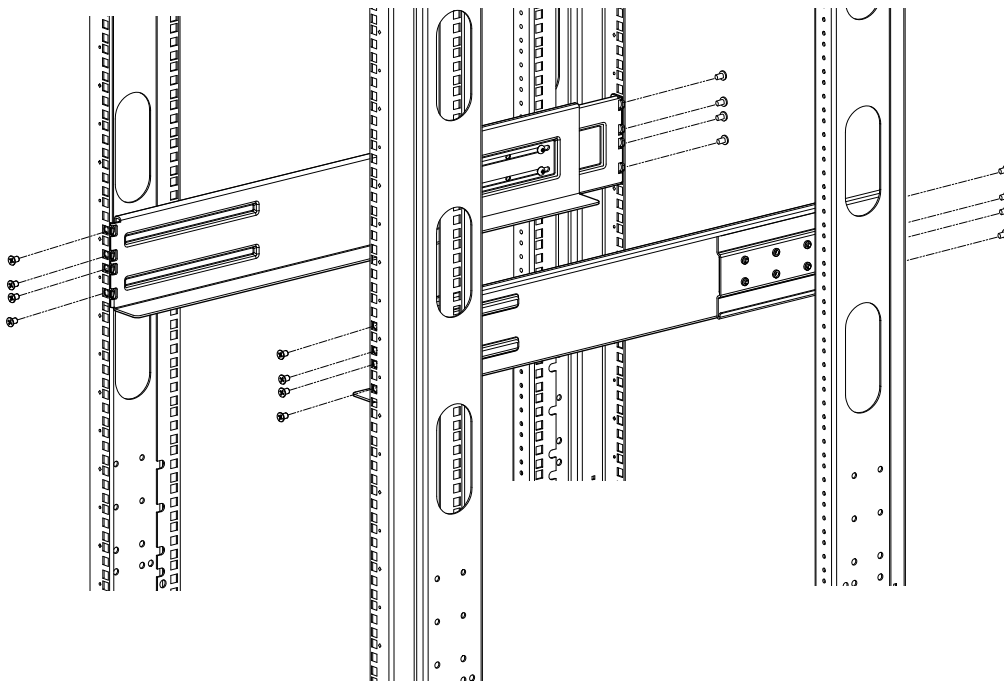

5. Use the mechanical lift to position the chassis as close to the rack as possible. Slide the chassis off the lift and onto the side rails and gently guide the chassis into the rack. Refer to [Figure 68](#).

2 Installing a Brocade MLXe-32 router

FIGURE 68 Slide the chassis in the rack

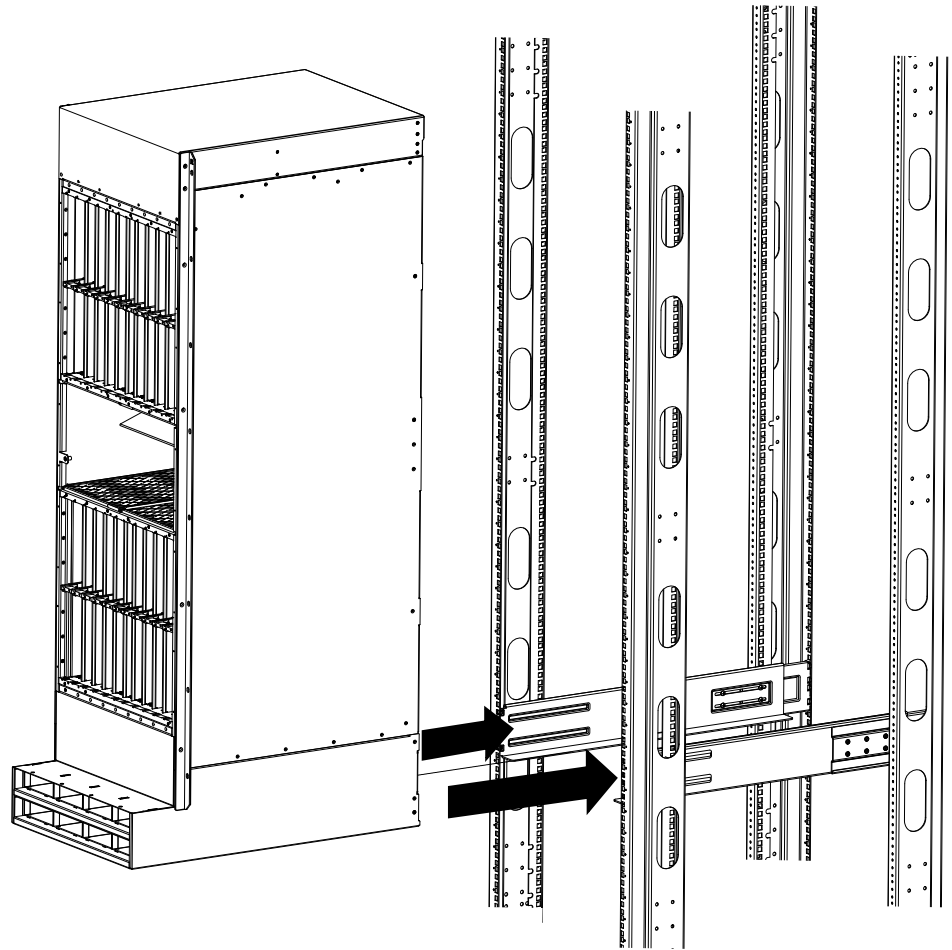

6. Once the chassis is securely inserted in the rack, fasten the mounting ears to the front rails of the rack using 10-32x.63 Phillips Square cone screws. Refer to [Figure 69](#).

FIGURE 69 Secure chassis in rack

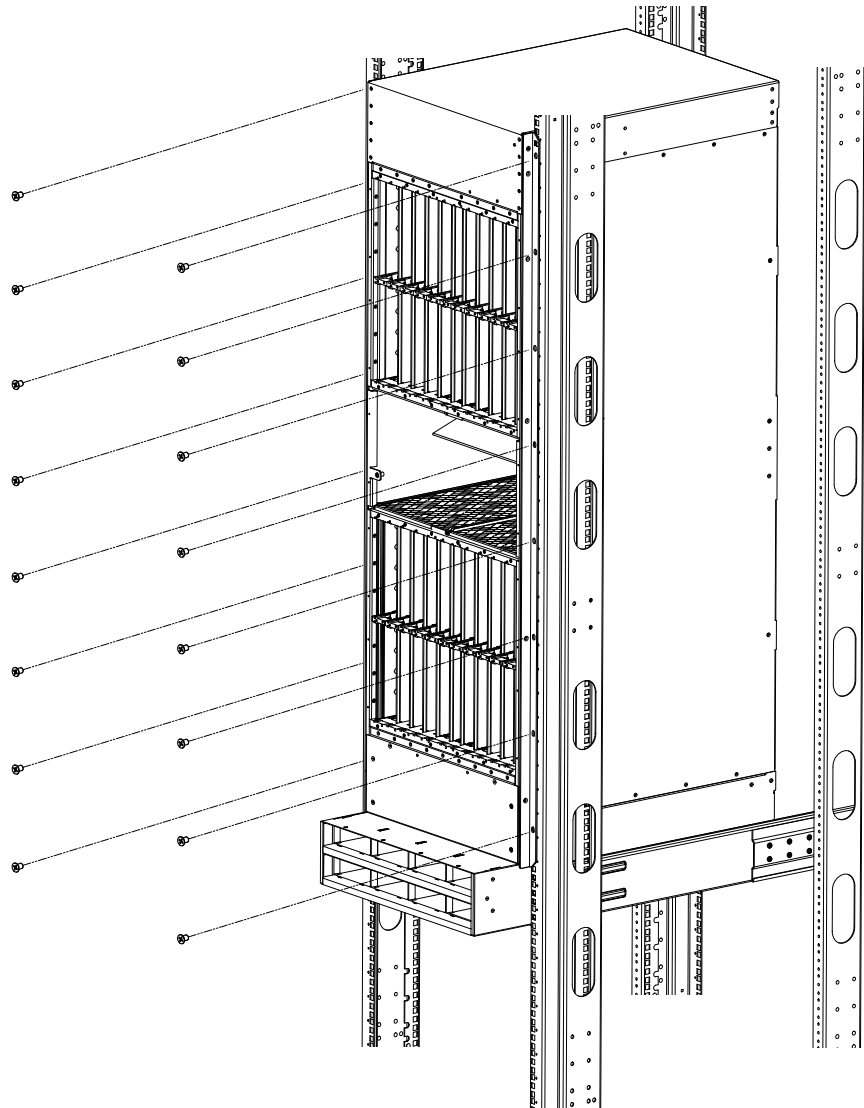

Your rack installation is complete.

Installing the rack mount kit on a 32-slot router in an open cabinet or a four-post flush-mount rack

You can mount the Brocade MLXe 32-slot routers in a four-post rack or open cabinet using the optional four-post flush-mount rack-mount kit RMK-4POST-MLXE-32.

NOTE

The RMK-4POST-MLXE-32 rack-mount kit cannot be used for installing the Brocade MLXe 32-slot routers in a cabinet with doors. For installing a Brocade MLXe-32 in a cabinet with doors, use the RMK-CAB-MLXE-32 rack mount kit which can be purchased from Brocade.

[Table 25](#) lists the contents of this kit.

2 Installing a Brocade MLXe-32 router

TABLE 25 Four-post flush-mount rack-mount kit contents

Part number	Description	Quantity	Notes
49-1000166-XX	27-31" rail, left	1	
49-1000167-XX	27-31" rail, right	1	
42-1000901-XX	Rack mount bracket, left	1	
42-1000902-XX	Rack mount bracket, right	1	
52-1000278-01	8-32 Phillips flat-head screws, black	10	Attaches the rack mount brackets to the chassis.
42-0200036-XX	Alignment Washer	16	Used with 52-1000138-01 (M6 Screws) to mount rails 49-1000166-XX and 49-100167-XX
52-0000211-01	10-32 X .63",Phillips Square Cone Screw	16	Secure the chassis in the rack or cabinet. Used in combination with either 52-0000210-01 or 52-0200270-01, whichever is appropriate for your rack type.
52-0000210-01	Nut,retainer,10-32	16	Used with part number 52-0000211-01.
52-1000138-01	M6 X 12MM, Phillips Square Cone Screw	16	Secures the left and right rails to the rack or cabinet.
52-0200270-01	Floating Clip Nut, 10-32	16	Used with part 52-0000211-01.

NOTE

Because of the weight of fully loaded routers, it is recommended that you mount the router in a rack or cabinet before installing modules and power supplies.

You will need the following items to install your 32-slot router in a four-post rack or cabinet:

- A mechanical lift tool fitted with a lift plate (instead of forks) to move the device off the pallet and transport it to the rack. The lift should be rated for 500 lbs. minimum.
- A strap to secure and stabilize the device while it is being moved on the mechanical lift.
- No. 2 Phillips screwdriver



DANGER

Four or more people are required to position the unpopulated router into the rack.



DANGER

Do not use the handles on the power supply units or fan modules to position the router.

Before installation, plan the location and orientation of the device relative to other equipment in the rack. For cooling purposes, allow a minimum of six inches of space between the front and back of the device, and walls or other obstructions.

Because you will need to use a mechanical lift to move and install the device, make sure you allow enough space to operate the lift. You will also need at least two people to slide the router off the lift and into the rack.

NOTE

The cable management on this chassis has been removed for clarity to show the installation of the new rack ears and the installation of the device into the rack. The cable management should remain on the chassis during the assembly process.

7. Remove the factory-installed mounting brackets from the router.
8. Attach the front right and left mounting brackets to the chassis using the 10 8-32 Phillips flat-head screws (Figure 70).

FIGURE 70 Attaching front right and left mounting brackets to the router chassis

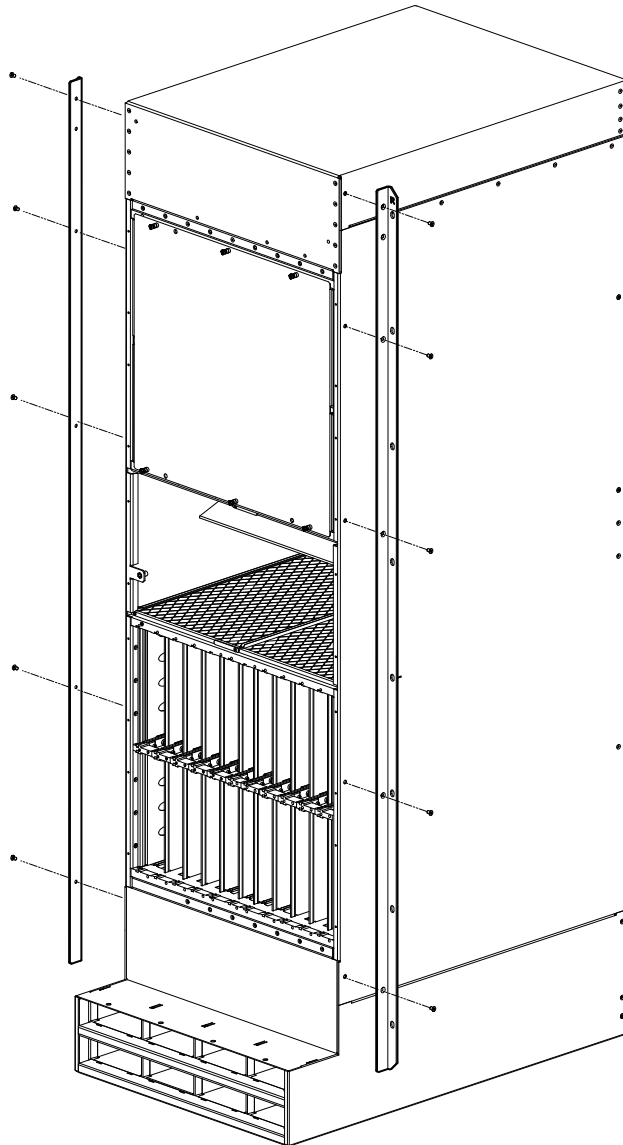

2 Installing a Brocade MLXe-32 router

9. Adjust the rails to fit your rack. The rails are telescoping and can accommodate rack depths from 27 through 31 inches.
10. Attach the rails to the front and back of the rack, using screws provided in the kit ([Figure 71](#)).

NOTE

The narrow telescoping ends of the rails should be attached at the back of the rack.

FIGURE 71 Attaching the telescoping side rails to the rack.

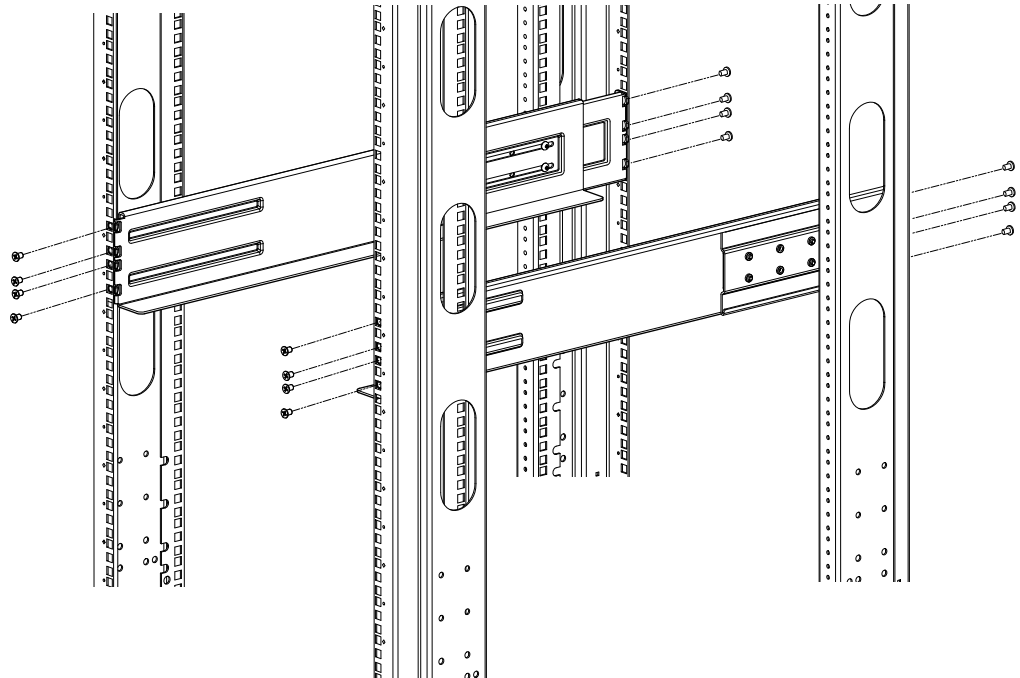

11. Use the mechanical lift to position the chassis as close to the rack as possible. Slide the chassis off the lift and onto the side rails and gently guide the chassis into the rack (Figure 72).

**DANGER**

Four or more people are required to position the unpopulated router into the rack.

**DANGER**

Do not use the handles on the power supply units or fan modules to position the router.

FIGURE 72 Sliding the chassis into the rack

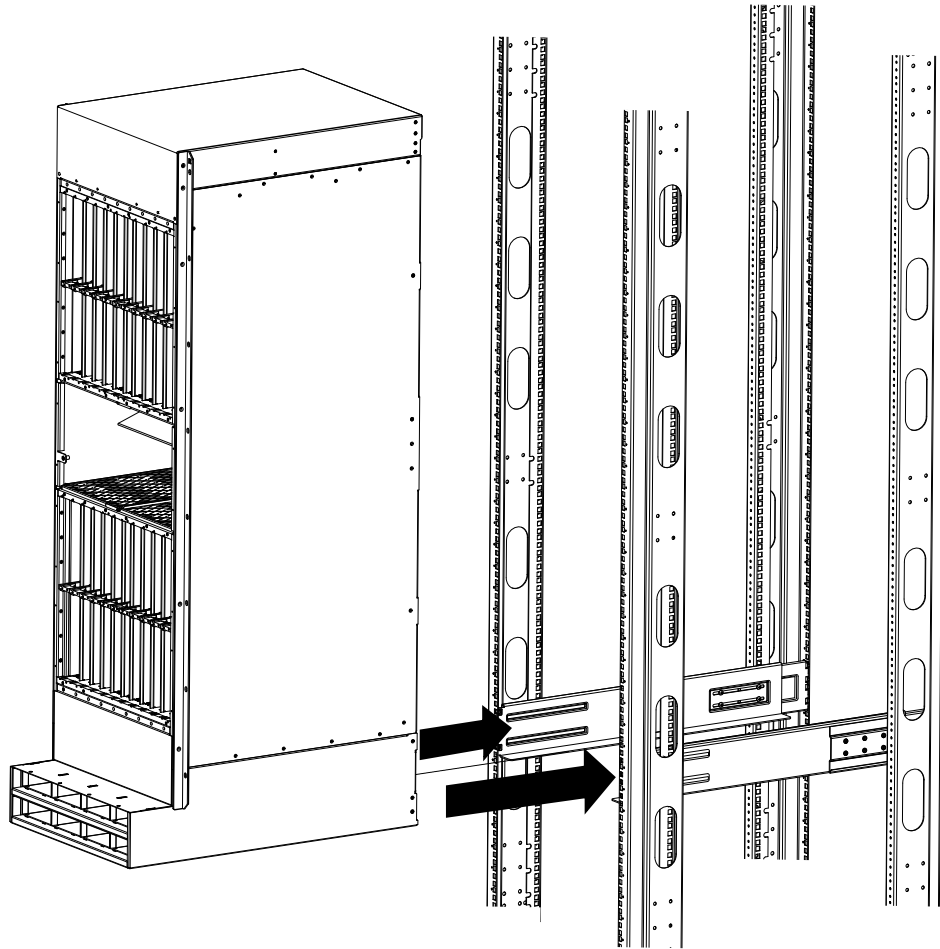

2 Installing a Brocade MLXe-32 router

12. Once the chassis is securely inserted in the rack, fasten the mounting brackets to the front rails of the rack using 10-32 screws (eight screws per side) and either clip nuts or floating nuts, whichever is appropriate for your rack type (Figure 73).

FIGURE 73 Securing the chassis in rack

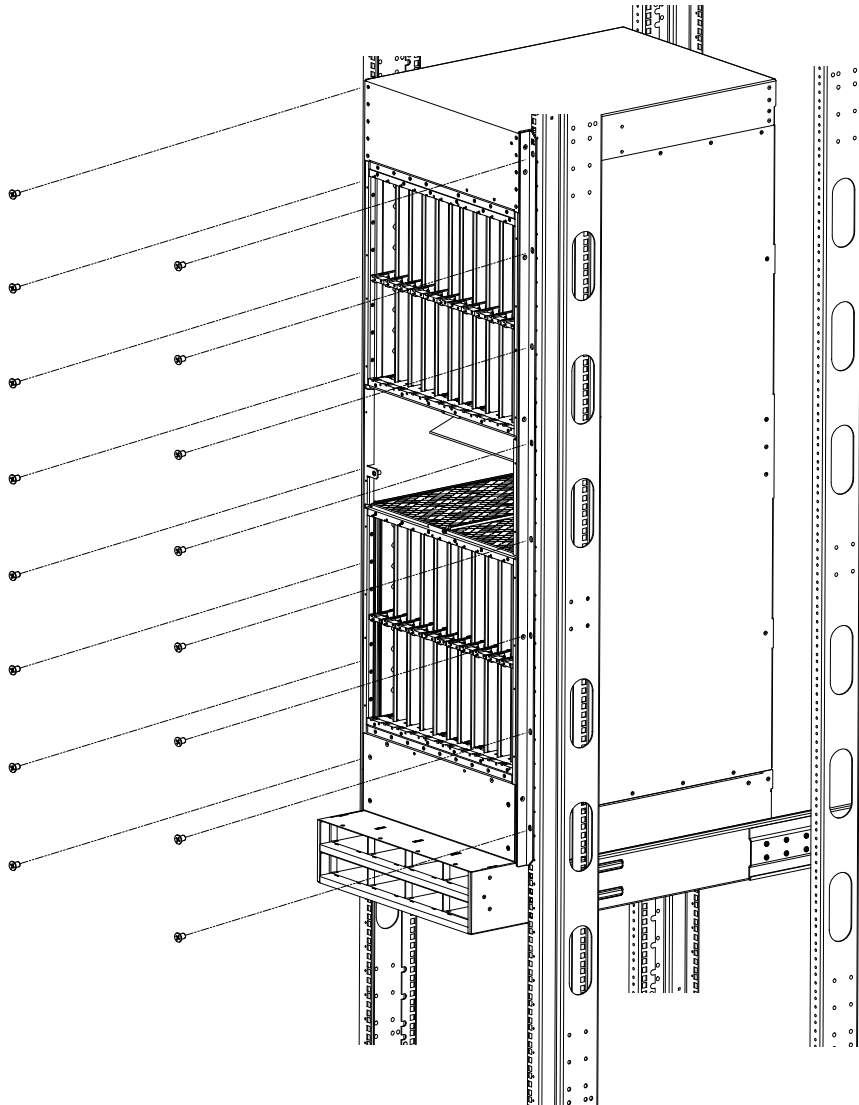

Your rack installation is complete.

Installing modules in the Brocade MLXe-32 router

The Brocade MLXe-32 router ships with empty module slots and upper and lower shipping panels installed.

For instructions about installing 2x100GbE interface modules, refer to [“Installing 2x100GbE interface modules in Brocade MLXe routers”](#) on page 43.

For instructions about installing BR-MLX-10Gx24-DM interface modules, refer to [“Installing BR-MLX-10Gx24-DM interface modules in Brocade MLXe routers”](#) on page 46.



DANGER

*The intra-building ports of the equipment or subassembly are suitable for connection to intra-building or unexposed wiring or cabling only. The intra-building ports of the equipment or subassembly **MUST NOT** be metallically connected to interfaces that connect to the outside plant (OSP) or its wiring. These interfaces are designed for use as intra-building interfaces only (Type 2 or Type 4 ports as described in GR-1089-CORE, Issue 5) and require isolation from the exposed OSP cabling. The addition of Primary Protectors is not sufficient protection in order to connect these interfaces metallically to OSP wiring.*

The sequence for installing management, interface, and switch fabric modules is important to ensure proper fit in the Brocade MLXe-32 router. When populating the router, start with the middle slot, and work towards the edge. Always fill the bottom slots of the upper and lower card cage of the router first. Refer to [Figure 4](#) on page 7 for slot locations.

During the initial installation of modules, it is recommended that you insert all the modules into the appropriate router slots before tightening the module screws.

For information about how to disable and re-enable power to interface modules, refer to [“Disabling and re-enabling power to interface modules”](#) on page 151

When populating the 32-slot router, the modules must be installed in the appropriate slots:

- Management modules: management slots 1 and 2
- Switch fabric modules: switch fabric slots 1-8
- Interface modules: Interface slots 1-32

Refer to [Figure 4](#) for the locations of these slots.

NOTE

Brocade MLXe modules are dedicated, which means that you must install them in the Brocade MLXe routers only. If you install a Brocade MLXe module in another Brocade router or a module intended for another Brocade router in the Brocade MLXe router, the router and module will not function properly.

Although management modules are designed to be hot-swappable, you must upgrade the software on all interface modules and management modules to the appropriate software release before installing them. For more information on the appropriate software release, refer to the Hardware Installation Notes that shipped with the management module.

2 Installing a Brocade MLXe-32 router

If you are installing a redundant management module, refer to the chapter titled *Using a Redundant Management Module* in the *Brocade MLX Series and Brocade NetIron Family Configuration Guide* for information about how the redundant module works, optional software configurations that you can perform, and how to manage the redundancy feature.

Before installing modules in the Brocade MLXe-32 router, have the following items available:

- A large flat-head screwdriver.
- An ESD wrist strap with a plug for connection to the ESD connector on the router.



DANGER

For safety reasons, the ESD wrist strap should contain a 1 megohm series resistor.



CAUTION

All empty module slots must have slot blanks installed. Operating the router without slot blanks may cause the router to overheat.



CAUTION

If you are hot-swapping a module, allow a minimum of two seconds after a module (or power supply or fan tray) has been removed before inserting a module in the same slot.

Follow these steps to install a module in the Brocade MLXe router.

1. If you are installing a module into a slot which may have been configured for a different module type, first remove the old configuration information by following these steps:
 - a. Use the **show running-config** command in config mode to determine the current configuration of the slot.

```
Brocade(config)# show running-config
Current configuration:
!
ver V5.0.0T163
module 1 ni-mlx-20-port-1g-copper
!
```

This example shows that slot 1 has already been configured for a 20-port 1 Gbps copper interface module.
 - b. Enter the **no module slot module** command to remove the configuration from slot 1. Use the slot and module information shown as a result of the **show running-config** command.

```
Brocade(config)# no module 1 ni-mlx-20-port-1g-copper
```

The command removes the configuration from slot 1, leaving it ready for a new module.
2. Put on the ESD wrist strap and ground yourself by inserting the plug into the ESD connector on the chassis.
3. Remove the module from the packaging.
4. Insert the module into the slot, and slide it along the card guide until the ejectors on either side of the module rotate towards the module faceplate. Refer to [Figure 74](#).

NOTE

When inserting the module into the router, make sure that the faceplate doesn't overlap the faceplate of an adjacent module.

5. Rotate the ejectors until they are flush with the module faceplate. This action will fully seat the module in the backplane.
6. Tighten the screws at each end of the module faceplate by pushing them in and turning them clockwise. Complete the tightening process using the flat-blade screwdriver.
7. Enter the **write memory** command to ensure that the slot will be correctly configured for the new module after a reboot.

```
Brocade(config)# write memory
Write startup-config done.
```

FIGURE 74 Installing a module in a Brocade MLXe-32 router

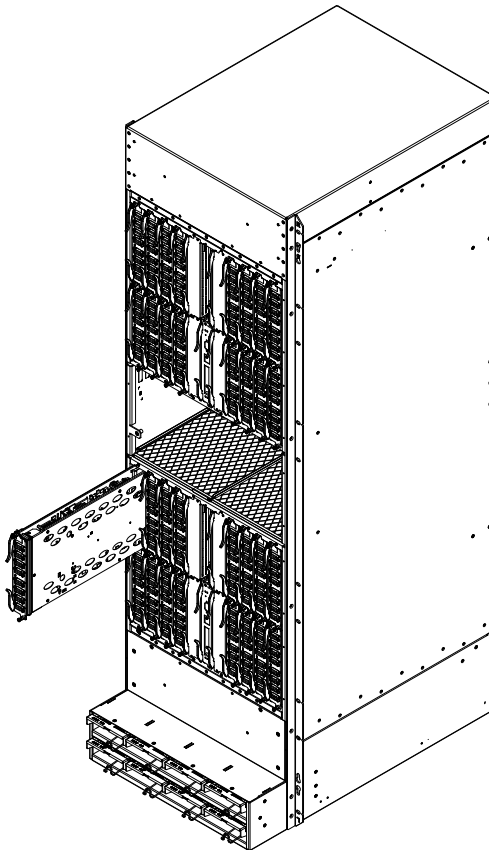

Power supply requirements for NI-MLX-1Gx48-T-A modules

You can install up to twenty NI-MLX-1Gx48-T-A modules and populate the remaining slots with other modules, which requires four 2400W power supplies. You can achieve 4+4 power redundancy by installing four additional power supplies.

If you install 21 or more NI-MLX-1Gx48-T-A modules in your router, you will need a minimum of five power supplies. You can achieve 5+3 power redundancy by installing three additional power supplies.

Using the insertion and extraction tool

Due to the high density of cables that the Brocade MLXe-32 router can support, it may be difficult to insert and remove the RJ45 and optical connectors. An insertion and extraction tool has been provided in the Brocade MLXe-32 accessory kit to make this task easier. Refer to [Figure 75](#).

FIGURE 75 insertion and extraction tool

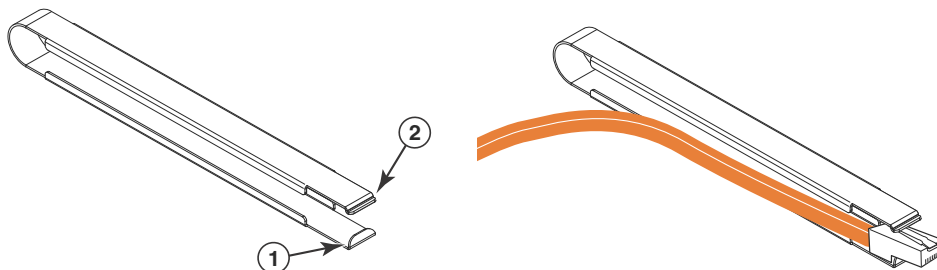

- 1 Hooked tab 2 Stepped tab

Use the tool to grasp the plug of the modular connector at its narrow end (the end closest to the attached cable), and insert the connector into the proper interface module. Grasping the plug at the wide end during insertion may result in the tool being difficult to release and remove.

When using the tool to extract the plug of a modular connector, cover the entire length of the plug with the tool. Notice that one end of the tool has a “hook” side. Use this side to compress the locking tab while you remove the connector.

Brocade MLXe-32 cable management

The Brocade MLXe-32 cable management system allows access to the power supplies at the bottom of the router, and keeps the air inlet clear in the center of the router (this is essential for proper cooling). Cable management hardware at the top, bottom and sides of the router make it easier to route the cables in the proper directions.

In general, cables from the outer interface modules are routed horizontally and away from the router. Cables from the remaining modules in the upper half of the router are routed up, then outwards along the channels.

Cables for modules in the lower half of the router follow a similar path downwards, above the power supplies. [Figure 76](#) shows the cable routing, with the upper and lower cable management system covers removed for clarity. The following sections describe cable routing for each quadrant of the router.

FIGURE 76 Brocade MLXe-32 cable routing diagram

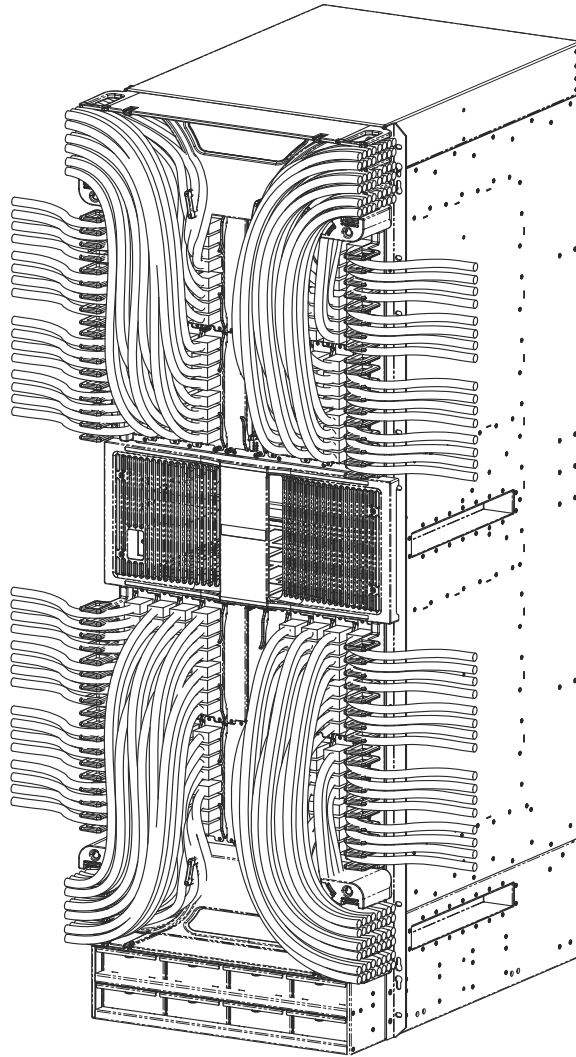
**CAUTION**

Be sure not to exceed the minimum recommended bend radius for the cables: 2 in. for MRJ-21 cables, and 1.5 in. for Category 5 (RJ45) and fiber-optic cables.

Cable routing for the upper-left quadrant

Route cabling from slots in numerical order starting with the cables for slot #1.

2 Installing a Brocade MLXe-32 router

1. Route cables for slots #1 and #2 directly to the left through the side comb. Refer to [Figure 77](#).

FIGURE 77 Routing upper-left quadrant cables

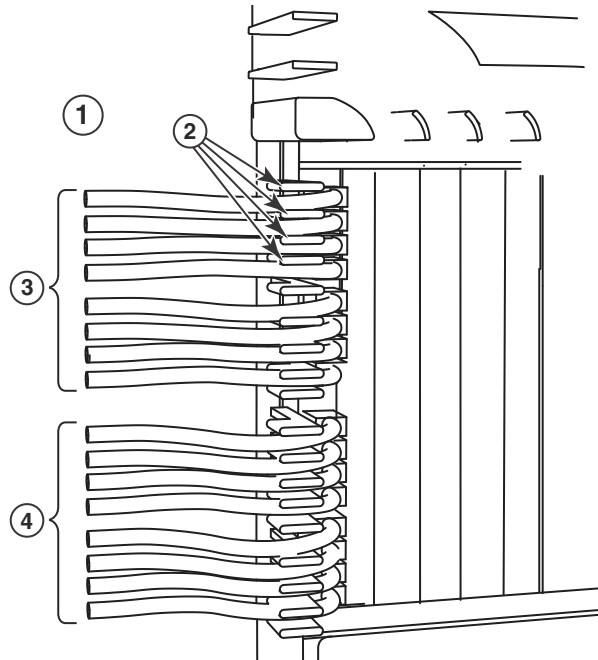

- | | | | |
|---|---------------------|---|---------------------|
| 1 | Upper left quadrant | 3 | Cables from slot #1 |
| 2 | Side combs (18) | 4 | Cables from slot #2 |

FIGURE 78 Routing upper-left quadrant cables up

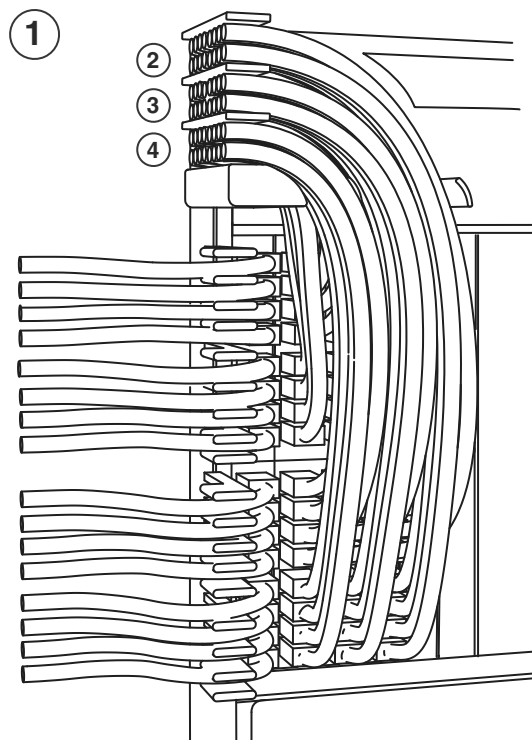

- | | | | |
|---|--------------------------------|---|--------------------------------|
| 1 | Upper left quadrant | 3 | Comb B (slot #5 and #6 cables) |
| 2 | Comb C (slot #7 and #8 cables) | 4 | Comb A (slot #3 and #4 cables) |

2. Route cables from slots #3 and #4 up through comb A. Refer to [Figure 78](#).
3. Route cables from slots #5 and #6 up through comb B.
4. Route cables from slots #7 and #8 up through comb C.

Cable routing for the upper-right quadrant

Route cables from slots in numerical order starting with the cables for slot #15.

1. Route cables from slots #15 and #16 directly to the right through the side comb. Refer to [Figure 79](#).

FIGURE 79 Routing Upper-right quadrant cables to the right

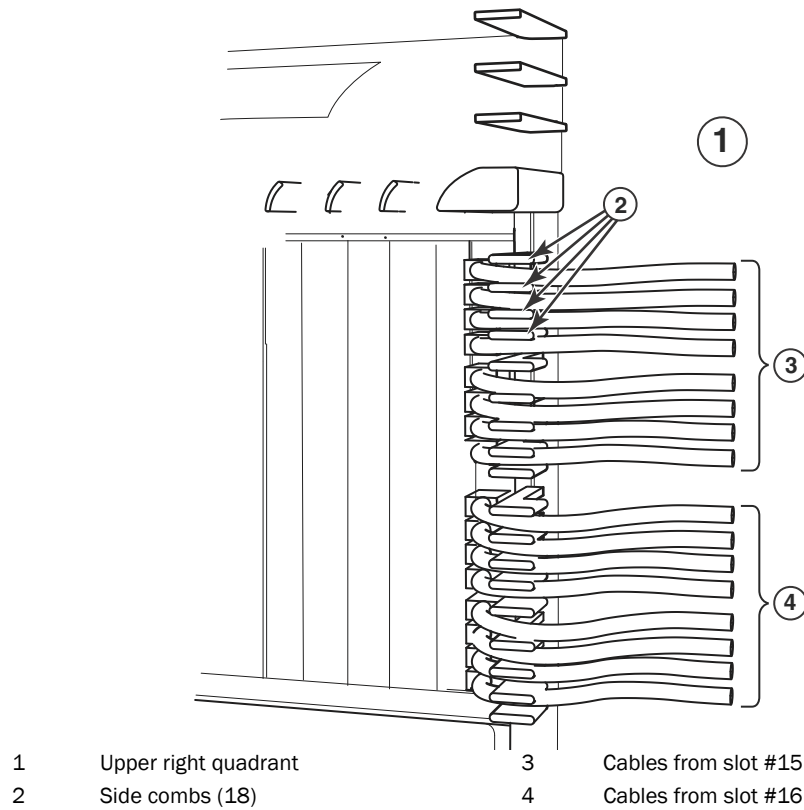

2 Installing a Brocade MLXe-32 router

FIGURE 80 Routing upper-right quadrant cables up

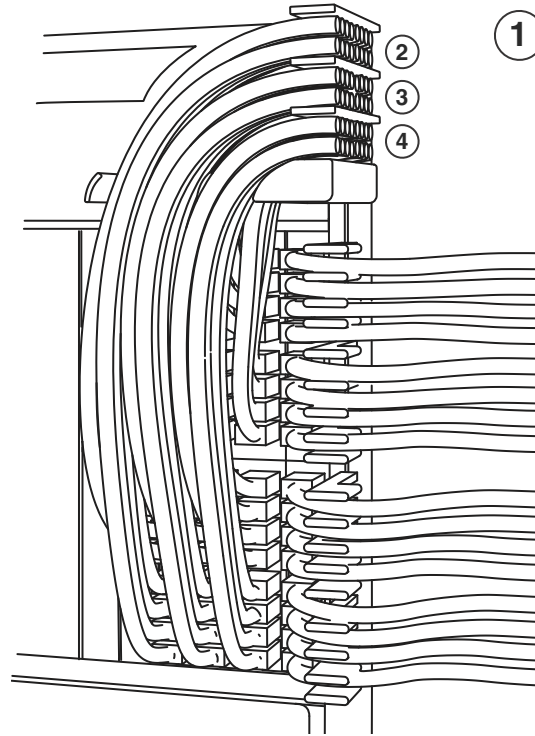

- | | | | |
|---|---------------------------------|---|----------------------------------|
| 1 | Upper right quadrant | 3 | Comb B (slot #11 and #12 cables) |
| 2 | Comb C (slot #9 and #10 cables) | 4 | Comb A (slot #13 and #14 cables) |
2. Route cables from slots #13 and #14 up through comb A. Refer to [Figure 80](#).
 3. Route cables from slots #11 and #12 up through comb B.
 4. Route cables from slots #9 and #10 up through comb C.

Cable routing for the lower-left quadrant

1. Route cables from slots #18 and #17 directly to the left through the side comb. Refer to [Figure 81](#).

FIGURE 81 Routing lower-left quadrant cables

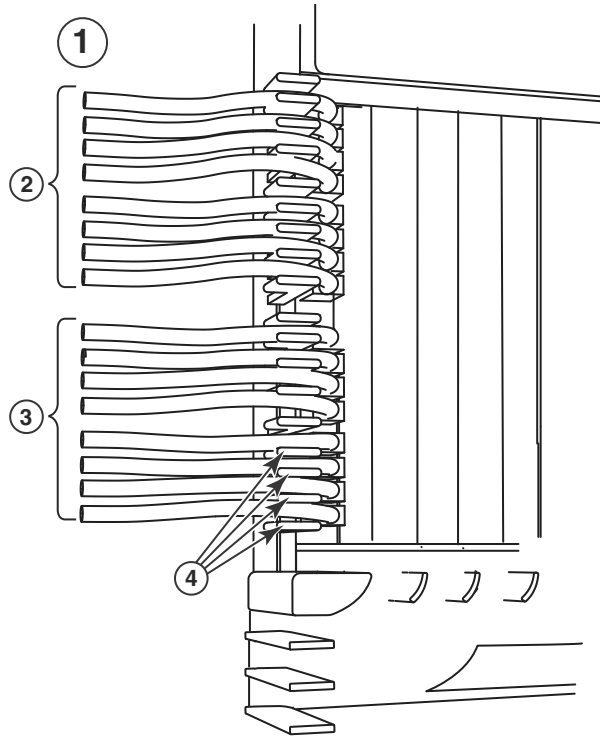

- | | | | |
|---|----------------------|---|----------------------|
| 1 | Lower left quadrant | 3 | Cables from slot #18 |
| 2 | Cables from slot #17 | 4 | Side combs (18) |

2 Installing a Brocade MLXe-32 router

FIGURE 82 Routing lower-left quadrant cables

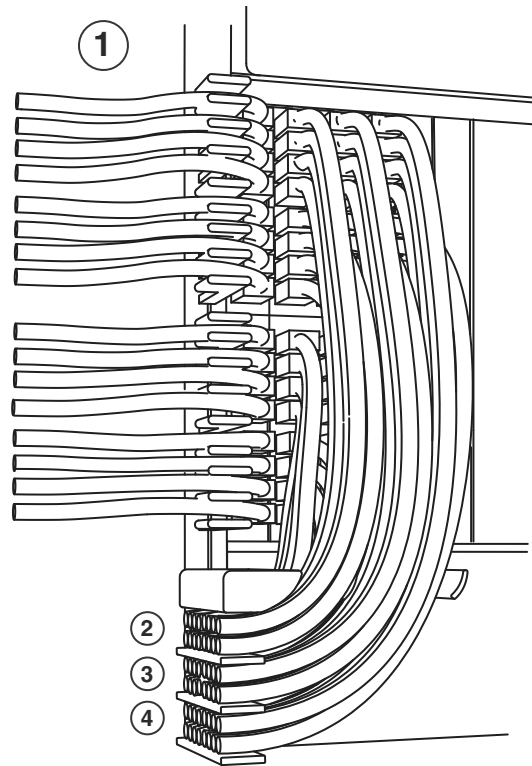

- | | | | |
|---|----------------------------------|---|----------------------------------|
| 1 | Lower left quadrant | 3 | Comb B (slot #21 and #22 cables) |
| 2 | Comb A (slot #19 and #20 cables) | 4 | Comb C (slot #23 and #24 cables) |

2. Route cables from slots #20 and #19 down through comb A. Refer to [Figure 81](#).
3. Route cables from slots #22 and #21 down through comb B.
4. Route cables from slots #24 and #23 down through comb C.

Cable routing for the lower-right quadrant

1. Route cables from slots #32 and #31 directly to the right through the side comb. Refer to [Figure 83](#).

FIGURE 83 Routing the lower-right quadrant cables

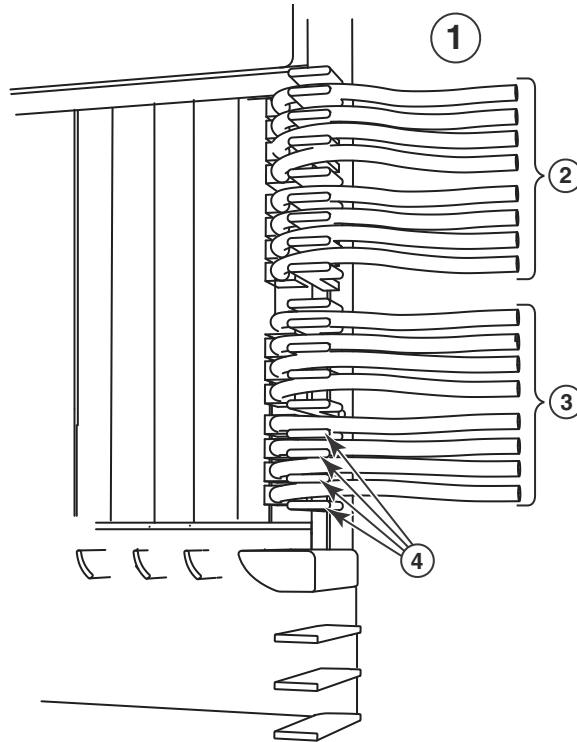

- | | | | |
|---|----------------------|---|----------------------|
| 1 | Lower right quadrant | 3 | Cables from slot #32 |
| 2 | Cables from slot #31 | 4 | Side combs (18) |

FIGURE 84 Routing lower-right quadrant cables

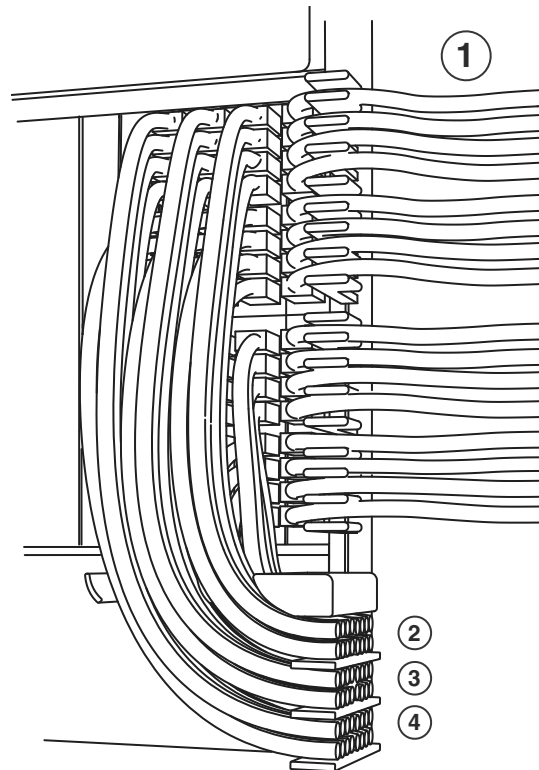

- | | | | |
|---|-----------------------------------|---|-----------------------------------|
| 1 | Lower right quadrant | 3 | Comb B (slots #27 and #28 cables) |
| 2 | Comb A (slots #29 and #30 cables) | 4 | Comb C (slots #25 and #26 cables) |
- Route cables from slots #30 and #29 down through comb A. Refer to [Figure 84](#).
 - Route cables from slots #28 and #27 down through comb B.
 - Route cables from slots #26 and #25 down through comb C.

Accessing modules for service

With the cables bundled correctly, it is easier to access the modules for service. Gently move the cable bundles to the side to access a module. Use the appropriate Phillips or flat-blade screwdriver with an extended shaft to disconnect the cables from the module and remove the module. There is no need to undo the cable cinches or cable ties. Refer to [Figure 85](#).

NOTE

This procedure is easier with two people. One person can hold the cable bundles aside while the other person loosens the connectors and removes the module.



CAUTION

Be careful not to overtighten or cross-thread cable connector screws.

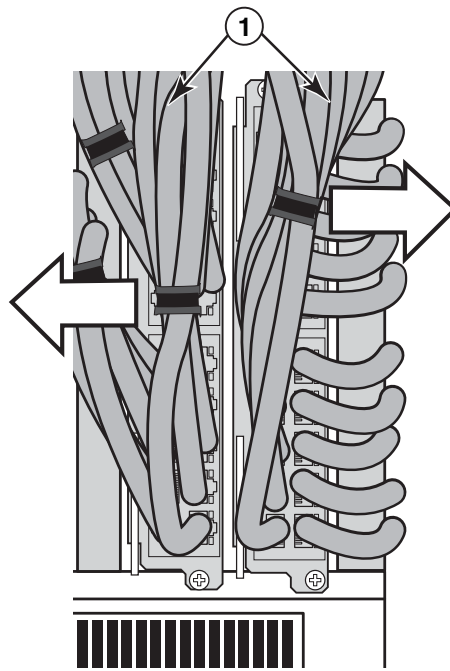
FIGURE 85 Accessing modules by shifting cable bundles

- 1 Cable bundles

Cable management notes

The following rules apply when setting up cable management for a heavily- or fully-loaded system:

2 Installing a Brocade MLXe-32 router

- All cables must be firmly connected, supported, and contained.
- Use cable cinches, spaced approximately every 24 inches, to secure all of the cables for each module into a single bundle. This is especially important at the ends nearest the module connections. Each cable cinch holds up to 8 MRJ21 cables, or 48 RJ45 cables.
- For additional security, use cable ties to secure cables to the cable management system hardware on the sides of the unit.
- The cable routing slots at the top and bottom of the unit are strong enough to hold many cables, but the more cable cinches and cable ties you use, the more secure your cable management system will be.
- If you bundle the cables correctly, you will be able to move the bundles to the side to access the modules for service, without disturbing the connections. Refer to [Figure 85](#).
- Always route the cables for the outer-most modules out the **sides** of the unit. Route the cables for the innermost modules through the top or through the bottom cable management hardware on the unit.

Installing power supplies in a Brocade MLXe-32 router



DANGER

High Touch Current. Earth connection is essential before connecting supply.

Follow these steps to install a power supply in a Brocade MLXe-32 router.

1. Remove the blank power supply faceplate.
2. Remove the power supply from the packaging.
3. Insert the power supply into the slot, using the guides on each side of the slot. Refer to [Figure 86](#).

FIGURE 86 Installing a power supply in a Brocade MLXe-32 router

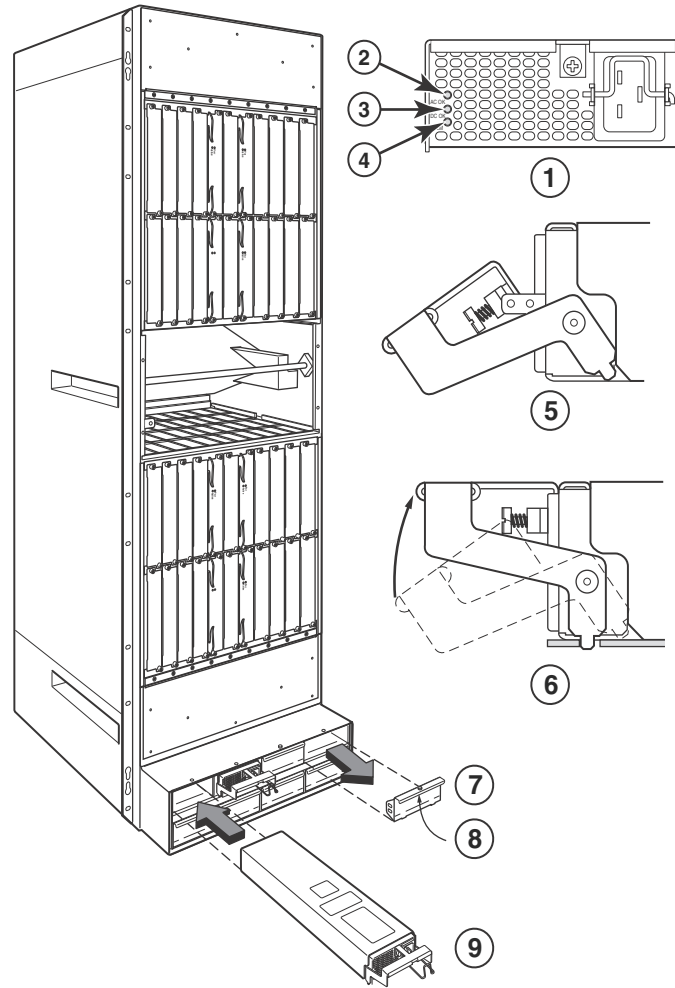

- | | | | |
|---|-------------------------|---|--------------------------------|
| 1 | Power supply indicators | 6 | Latch handle locked |
| 2 | AC OK | 7 | Power supply blank cover |
| 3 | DC OK | 8 | Pull down on plunger to remove |
| 4 | ALM | 9 | Power supply |
| 5 | Latch handle open | | |

**CAUTION**

Carefully follow the mechanical guides on each side of the power supply slot and make sure the power supply is properly inserted in the guides. Never insert the power supply upside down.

4. Push the power supply front panel toward the back of the router to engage the backplane connector.
5. Pull the release latch on the power supply front panel up to lock the power supply in place.
6. Use a #2 Phillips to screw the locking screw into place.
7. Install a blank power supply faceplate into each empty slot.

For information about connecting power to the router, refer to [“Connecting AC power”](#) on page 120.

2 Installing a Brocade MLXe-32 router

For information about powering on the system, refer to “Activating the power source” on page 124.

Connecting AC power

NOTE

For the NEBS-compliant installation, AC power connections must use a surge protection device (SPD) to protect the AC power supplies from damage due to excessive power line surges.

AC power is supplied through a power cord that is connected to each power supply in the Brocade MLXe-32 router. Follow the steps below to connect AC power to a Brocade MLXe-32 router:

1. Locate the power receptacle on each installed power supply. Refer to [Figure 87](#).
2. Lift the cord retainer and connect an AC power cord to the power supply.
3. Snap the cord retainer over the power plug to hold it in place.

FIGURE 87 Brocade MLXe-32 power supply receptacle and cord retainer

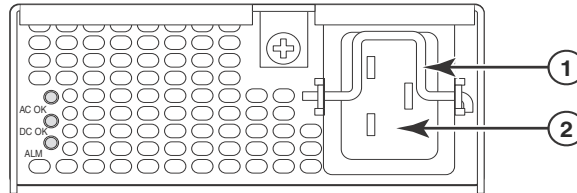

- 1 Cord retainer 2 Power receptacle

Connecting DC power

You can use a DC power source for the Brocade MLXe-32 router by installing a DC-to-DC power supply. For 2400W power supplies, DC power must be supplied at 48 V and 60 A. For 3000W power supplies, power must be supplied at 48 V and 90 A. The 2400W DC-to-DC supply provides the DC power to the router at 12 V and 200 A. The 3000W DC-to-DC power supply provides the DC power to the router at 12 V and 245 A.

**DANGER**

The procedure in this section is for qualified service personnel.

Follow these steps to connect a DC power source.

1. Use a #1 Phillips screwdriver to remove the screw that secures the safety cover, as shown in [Figure 88](#). Remove the safety cover.

FIGURE 88 Removing the safety cover (2400W power supply and 3000W power supply displayed)

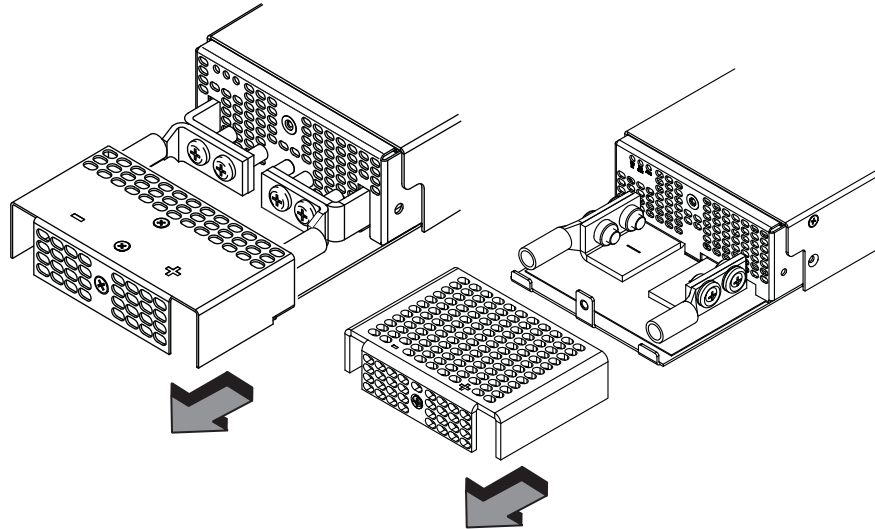

2. Use a #2 Phillips screwdriver to unscrew the power lugs. Refer to [Figure 89](#).

FIGURE 89 Removing the power lugs (2400W power supply and 3000W power supply displayed)

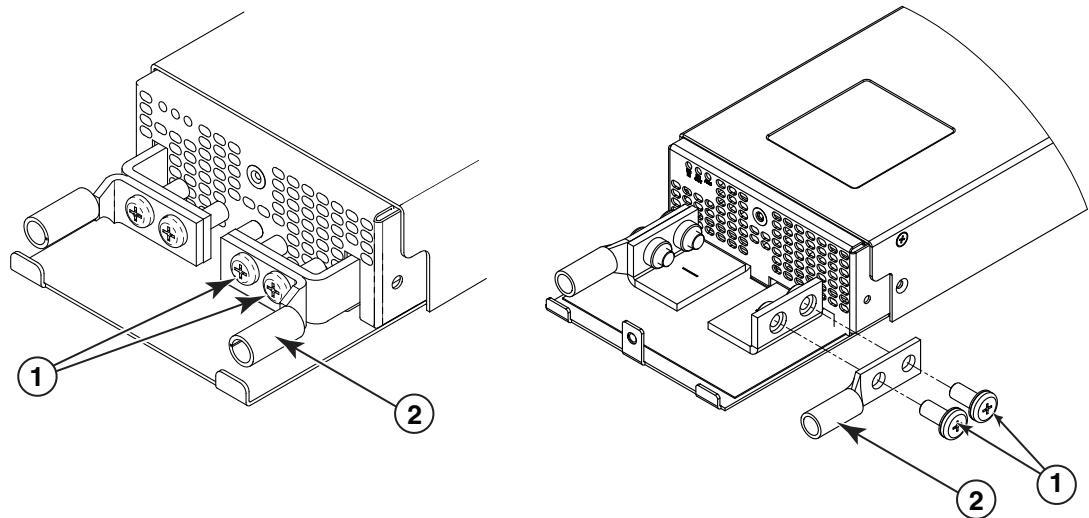

- 1 Power lug screws
 - 2 Power lug
3. Crimp the correct AWG power supply wire into the power lugs.
For 2400W power supplies: #4 AWG power supply wire
For 3000W power supplies: #2 AWG power supply wire
Refer to [Figure 90](#).



CAUTION

For the NEBS-compliant installation of 32-slot routers with AC and DC systems, use a ground wire of at least 2 American Wire Gauge (AWG). The ground wire should have an agency-approved crimped connector (provided with the device) attached to one end, with the other end attached to building ground. The connector must be crimped with the proper tool, allowing it to be connected to both ground screws on the enclosure. Before crimping the ground wire into the provided ground lug, ensure the bare copper wire has been cleaned and antioxidant is applied to the bare wire.



CAUTION

To ensure adequate bonding when attaching the ground lug, a minimum of 20 PSI of torque is required to be applied to the mounting hardware used to attach the ground lug.

FIGURE 90 Crimping the power supply wire in the lug

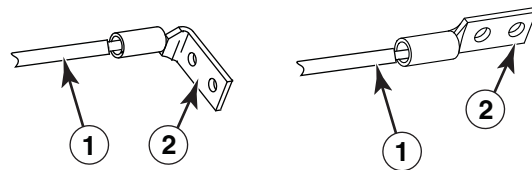

- 1 AWG power supply wire:
for 2400W power supply, use #4 AWG
for 3000W power supply, use #2 AWG
 - 2 Power lug
4. Reconnect the power lugs to the power supply unit.
 5. Connect the -48V wire to the negative terminal and the 0V wire to the positive terminal.

NOTE

DC return must be isolated from the router ground (DC-I) when making connections to the connections to the power supply.

6. Replace the safety cover. Refer to [Figure 88](#).

This equipment installation must meet NEC/CEC code requirements. Consult local authorities for regulations.

Removing Brocade MLXe-32 router DC power supplies

Follow these steps to remove a 2400W DC power supply in a Brocade MLXe-32 router:

1. Ensure the main DC power breaker is OFF.
2. Use a #1 Phillips screwdriver to remove screw that secures the safety cover, as shown in [Figure 88](#) on page 121. Remove the safety cover.
3. Use a #2 Phillips screwdriver to remove the screws securing the power lugs. Refer to [Figure 89](#) on page 121.
4. Pull down on handle to remove power supply. Refer to [Figure 86](#) on page 119.

Follow these steps to remove a 3000W DC power supply in a Brocade MLXe-32 router:

1. Ensure the main DC power breaker is OFF.
2. Use a #1 Phillips screwdriver to remove the screw that secures the safety cover, as shown in [Figure 88](#) on page 121.
3. Pull down on the handle to remove the 3000W power supply. Refer to [Figure 86](#) on page 119.
4. Use a #2 Phillips screwdriver to remove the screws securing the power lugs. Refer to [Figure 89](#) on page 121.

Final steps

Complete these steps in the order in which they are listed:

- [“Attaching a management station”](#)
- [“Activating the power source”](#)
- [“Verifying proper operation”](#)

Attaching a management station

You can manage your router in the following ways:

- Connect a PC or terminal to the console port on the management module. From this port, you can assign an IP address to the management module and establish connections through Telnet or SSH.
- Connect the router to your existing management network and manage the router and other network devices from a management station.

NOTE

The management network that you connect to through the 10/100 Ethernet port must be separate and isolated from the network over which user packets are switched and routed. For information about functionality on the management port, Refer to [“Understanding management port functions”](#) on page 145.

Attaching a PC or terminal to the console port or Ethernet port

You can attach a PC or terminal to either the console port (which has a male DB-9 serial connector), or the 10/100/1000 or 1000Base TX Ethernet port (which has an RJ45 UTP connector) on the management module. From the console port, you can access the router CLI directly from the PC or terminal or through a Telnet connection. From the Ethernet port, you can access the router CLI or Web management interface directly from the PC or terminal or through a Telnet connection.

Before performing this task, have the following items available.

2 Activating the power source

- PC running a terminal emulation application or a terminal.
- For console port connections, a straight-through EIA or TIA DB-9 serial cable with one end terminated in a female DB-9 connector and the other end terminated in a male or female DB-9 or DB-25 connector, depending on the specifications of your PC or terminal. You can order this cable from Brocade or build your own cable. If you build your own cable, refer to the pinout information in [“Console port pin assignments”](#) on page 218.
- For Ethernet port connections, a Category 5 UTP crossover cable, which you must supply. For information about the management port pin assignments, refer to [“Management port pin assignments”](#) on page 219.

Follow these steps to attach a PC or terminal to the console port or Ethernet port.

1. Connect a PC or terminal to the console port or Ethernet port using the appropriate cable.
2. Open the terminal emulation program, and set the session parameters as follows:
 - **Baud:** 9600 bps
 - **Data bits:** 8
 - **Parity:** None
 - **Stop bits:** 1
 - **Flow control:** None

Activating the power source

When you complete the hardware installation, you are ready to activate the power source.

1. Verify that all modules and power supplies are properly installed and all empty slots are covered by slot blanks.



CAUTION

If you do not install a module in a slot, you must keep the slot blank in place. If you run the router with an uncovered slot, the system may overheat.

2. If you are supplying a DC power source to your router, attach a power cable to each installed DC power supply as described in the appropriate section:

Connect the other end of each cable to the DC power source. When you have completed these steps for each power supply you can activate the power source.

3. If you are supplying AC power to your router, attach one end of an AC power cord to each installed AC power supply as described in the appropriate section:

Insert the other end of each cable into a wall outlet. The following rules apply:

- 1200W power supplies require 115V/120V outlets.
- 1800W power supplies require 200V-240V for full power or are limited to 1200W with 115V/120V outlets.

- 2400W and 3000W power supplies require high line (200V-240V) outlets.

**DANGER**

If the installation requires a different power cord than the one supplied with the router, make sure you use a power cord displaying the mark of the safety agency that defines the regulations for power cords in your country. The mark is your assurance that the power cord can be used safely with the router.

NOTE

Because the router is designed to provide uninterrupted service even when you insert or remove management modules and interface modules, there is no on/off power switch. To turn the system off, simply unplug the power cords.

NOTE

Wall outlets should be installed near the equipment and should be easily accessible.

4. Verify that the router has initialized successfully. Refer to “[Verifying proper operation](#)” on page 125.

Verifying proper operation

To verify that your router is operating properly, observe the LEDs, or display the status of the modules using the CLI.

Observing the LEDs

When power is supplied to the router, you can observe the LEDs to verify that the router initialized successfully. [Table 26](#) describes the LEDs, the desired state of each LED, possible abnormal states of each LED, and what to do if an LED indicates an abnormal state.

TABLE 26 Router LED states and actions

LED label	Desired state	Meaning	Abnormal state	Meaning or action
Management module				
Active	The Active LED on one of the installed management modules should be on.	The module is functioning as the active management module.	Off	Neither of the management modules is managing the switch fabric and interface modules. A problem may have occurred during initialization. Check your attached PC or terminal for possible error messages.
Pwr	On	The module is receiving power.	Off	The module is not receiving power. Check the following: <ul style="list-style-type: none"> • Make certain that the module is installed properly. For more information, refer to the module installation section in this chapter that applies to your router model. • If you are using AC power supplies, refer to the AC power supply LED information in this table for more information.

2 Verifying proper operation

TABLE 26 Router LED states and actions (Continued)

LED label	Desired state	Meaning	Abnormal state	Meaning or action
10/100/1000 Ethernet Port	On (green)	A link is established with the remote port.	Off	A link is not established with the remote port. Check the following: <ul style="list-style-type: none"> Verify that the connection to the other router has been properly made. Also, make certain that the other router is powered on and operating correctly. Try using a different cable.
10/100/1000 Ethernet Port	On or blinking (yellow)	The port is transmitting and receiving packets.	Off for an extended period	The port is not transmitting or receiving packets. Check the following: <ul style="list-style-type: none"> Look at the LED for the other 10/100/1000 Ethernet port to see if a link has been established with the remote port. Verify that the connection to the other router has been properly made. Also, make certain that the other router is powered on and operating correctly. Try using a different cable.
Interface module				
Pwr	On	The module is receiving power.	Off	The module is not receiving power. Check the following: <ul style="list-style-type: none"> Make certain that the module is installed properly. For more information, refer to the module installation section in this chapter that applies to your router model. The module may not be receiving enough power. Brocade recommends installing power supplies in a fully redundant configuration as described for each router model in this chapter. Check the Pwr LED on the management module. If it is on, the management module may be preventing power from getting to the interface module. Enter the show chassis command at any level of the CLI to determine if the management module recognizes the presence of all power sources. If you are using AC power supplies, see the entry for the AC power supply LED in this table for more information.
Mgmt Act	During initialization: steady blinking. After initialization: occasional blinking.	The active management module processor and the interface module processor are communicating.	Off for an extended period.	The interface module may be in interactive mode. Check the status of the module by entering the show module command at any level of the CLI.
Link	On	A link is established with the remote port.	Off	This LED will remain off until you have cabled the interface module ports. After cabling the ports, if this LED is still off, a link is not established with the remote port. For more information, refer to Table 28 on page 148.
Active	On or blinking	The port is transmitting and receiving user packets.	Off for an extended period.	This LED will remain off until you have cabled the interface module ports. After cabling the ports, if this LED is still off, the port is not transmitting or receiving user packets. For more information, refer to Table 28 on page 148.

Switch Fabric module

TABLE 26 Router LED states and actions (Continued)

LED label	Desired state	Meaning	Abnormal state	Meaning or action
Pwr	On	The module is receiving power.	Off	The module is not receiving power. Check the following: <ul style="list-style-type: none"> • Make certain that the module is installed properly. For more information, refer to the module installation section in this chapter that applies to your router model. • If you are using AC power supplies, refer to the AC power supply LED information in this table for more information.
Active	On	The switch fabric module is active and ready to switch user packets.	Off for an extended period.	The switch fabric module is not active and user packets are not being switched from one interface module to another. You must replace the switch fabric module. Refer to “Replacing a switch fabric module” on page 192.
AC power supplies				
AC OK	Green (steady)	The power supply is receiving power from the AC power source.	Off	The power supply is not receiving power from an AC power source. You can do the following: <ul style="list-style-type: none"> • Make sure that the power cord is connected securely to the wall outlet and the power supply. • Make sure that the wall outlet is rated for 115/120V and 20A. If it is not, obtain a cable that is rated for the outlet. • Make sure that the wall outlet has power.
DC OK	Green (steady)	The power supply is providing AC power to the router.	Off	The power supply is not supplying power to the router. If the AC LED is green, there is a problem with the power supply and it must be replaced.
ALM	Off	The power supply is in normal operating condition.	Amber	The power supply is malfunctioning.
DC power supplies				
DC IN	Green (steady)	The power supply is receiving power from the DC power source.	Off	The power supply is not receiving power from a DC power source. You can do the following: <ul style="list-style-type: none"> • Make sure that the power supply cables are connected securely to the power source and the power supply. • Make sure the wall outlet is rated for high line, 200-240 VAC and 20A. If it is not obtain a cable that is rated for the outlet. • Make sure that the power source has power.
DC OUT	Green (steady)	The power supply is providing DC power to the router.	Off	The power supply is not supplying power to the router. If the DC IN LED is green, then there is a problem with the power supply and it must be replaced.
ALM	Off	The power supply is in normal operating condition.	Amber	The power supply is malfunctioning.

2 Verifying proper operation

TABLE 26 Router LED states and actions (Continued)

LED label	Desired state	Meaning	Abnormal state	Meaning or action
Fan control module (two LEDs on rear panel of router)				
Unlabeled	Green (steady)	The fans are working and responding to controls from the fan control module.	Off or amber	<p>The fans are not receiving power (off), or the fans are not working and not responding to controls from the fan control module (amber). Check the following:</p> <ul style="list-style-type: none"> • If the LED is off, check the power LED on the other modules to make sure they are receiving power. If you are using a DC power source, check your power source for problems. • If you are using AC power supplies, take the actions described in the Meaning or Action column for the AC power supply LED. If these actions do not resolve the problem, check the LED on each power supply or enter the show chassis command at any CLI prompt to determine if a power supply has failed. If a power supply has failed, you must replace it. • If the LED is amber, you must replace the fan module.

If a problem persists after taking the actions described in this table, contact technical support.

Displaying the module status

After you have attached a PC or terminal to the console port or Ethernet port on the management module and the router has initialized successfully, press **Enter** to display the CLI prompt in the terminal emulation window. This example is a prompt for a 16-slot router.

```
Brocade>
```

If you do not see this prompt, check the following items.

1. Make sure the cable is securely connected to your PC or terminal and the console port or Ethernet port.
2. Check the settings in your terminal emulation program. In addition to the session settings listed in [“Attaching a PC or terminal to the console port or Ethernet port”](#) on page 123, make sure the terminal emulation session is running on the same serial port you attached to the console port.

When you see this prompt (MLXe-16# or MLXe-32#), you are connected to the system and can display module status using the CLI. Enter the **show module** command at any CLI level.

```
MLXe-32# show module
      Module                               Status      Ports Starting MAC
M1 (upper): Brocade MLXe Mgmt Module      Active
M2 (lower):
F0: Brocade MLXe Switch Fabric Module     Active
S1:
S2:
S3:
S4: Brocade MLXe 4-Port 10Gig Module      CARD_STATE_UP 4 000c.db80.0000
S5: Brocade MLXe 4-Port 10Gig Module      CARD_STATE_UP 4 000c.db80.0000
S6: Brocade MLXe 4-Port 10Gig Module      CARD_STATE_UP 4 000c.db80.0000
S7:
S8:
```

Syntax: show module

The Status column shows the module status. The management module status can be one of the following:

- **ACTIVE** – The module is currently the active management module.
- **STANDBY** – The module is currently the standby management module.
- **COMING UP** – The module is coming up as the standby module. This status occurs if the standby management module becomes the active module during a switchover.

The switch fabric module status can be one of the following:

- **ACTIVE** – The module is up and running.
- **BAD** – The management module cannot initialize the switch fabric module.

An interface module status can be one of the following:

- **CARD_STATE_INIT** – The system detects the module but the module is not up and running yet.
- **CARD_STATE_BOOT** – The module is booting.
- **CARD_STATE_INTERACTIVE** – The module is booting from interactive mode.
- **CARD_STATE_LP_SYNC** – The software images are synchronized between the management module and interface module.
- **CARD_STATE_SYNC** – The system is currently synchronizing the software image between the management module and interface module.
- **CARD_STATE_SOFTWARE_LOADED** – The module has loaded the software image.
- **CARD_STATE_POWER_OFF** – The module does not have power.
- **CARD_STATE_UP** – The module is operating normally.
- **CARD_STATE_FAILED** – The management module was unable to bring up an interface module. If you see this status, make certain that the interface module is installed properly. For more information, refer to [“Installing modules in a Brocade MLXe 16-slot router”](#) on page 70, or [“Installing modules in the Brocade MLXe-32 router”](#) on page 105.
- **CARD_DOWN_REASON_ *explanation*** – The module is in a nonfunctional state. This status appears with an explanation for why the module is down. For example, "CARD_DOWN_REASON_BOOT_FAILED." If the explanation does not help you resolve the problem, contact technical support and provide the explanation included with this status.

2 Verifying proper operation

Using Brocade Structured Cabling Components

Cable cinch overview

Position the cable cinch with the open end to the left (no slot) as shown in [Figure 91](#).

FIGURE 91 Cable cinch overview

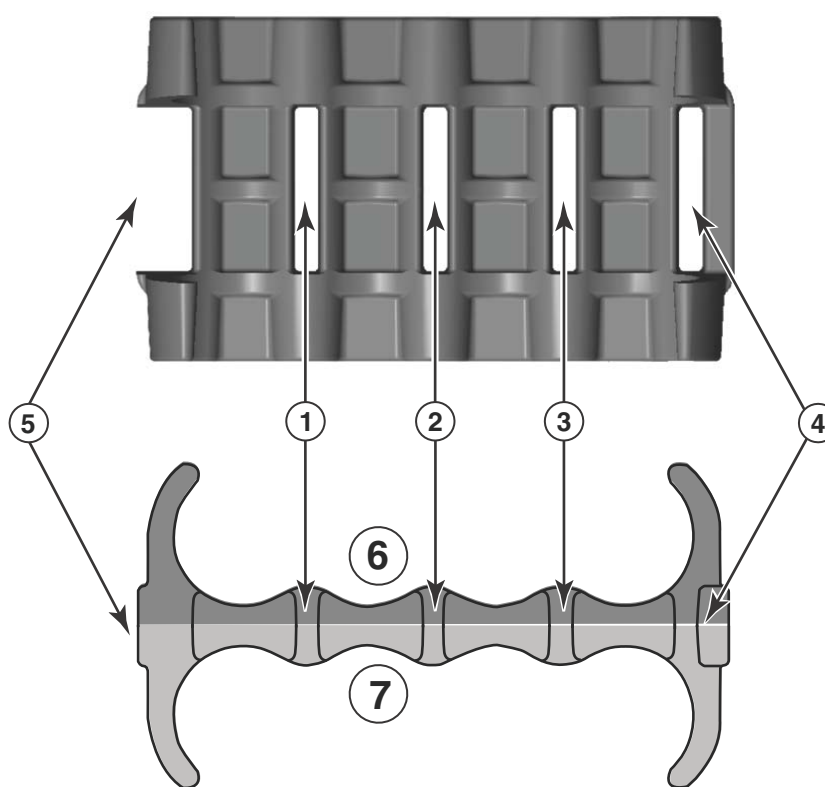

- | | | | |
|---|--------|---|----------|
| 1 | Slot 1 | 5 | Open end |
| 2 | Slot 2 | 6 | Rear |
| 3 | Slot 3 | 7 | Front |
| 4 | Slot 4 | | |

mRJ21 procedures

The following procedure demonstrates securing up to eight mRJ21 cables into the cable cinch. When securing fewer than the maximum cables, follow the procedure to secure the desired number of cables and simply wrap the remaining Velcro strap around the cable cinch. Use the additional slots in the clip to secure groups of cables as required.

Cable cinch with two mRJ21 cables

To secure two mRJ21 cables, place the Velcro strap through slot one and use the front and rear left recesses as shown in [Figure 92](#).

FIGURE 92 Two mRJ21 cables

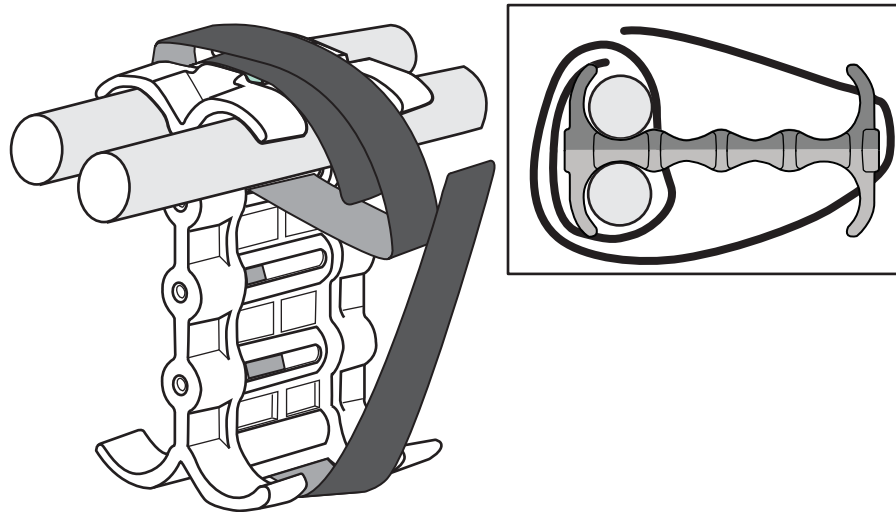

Cable cinch with three mRJ21 cables

Three mRJ21 cables may be secured as shown in [Figure 93](#).

FIGURE 93 Three mRJ21 cables

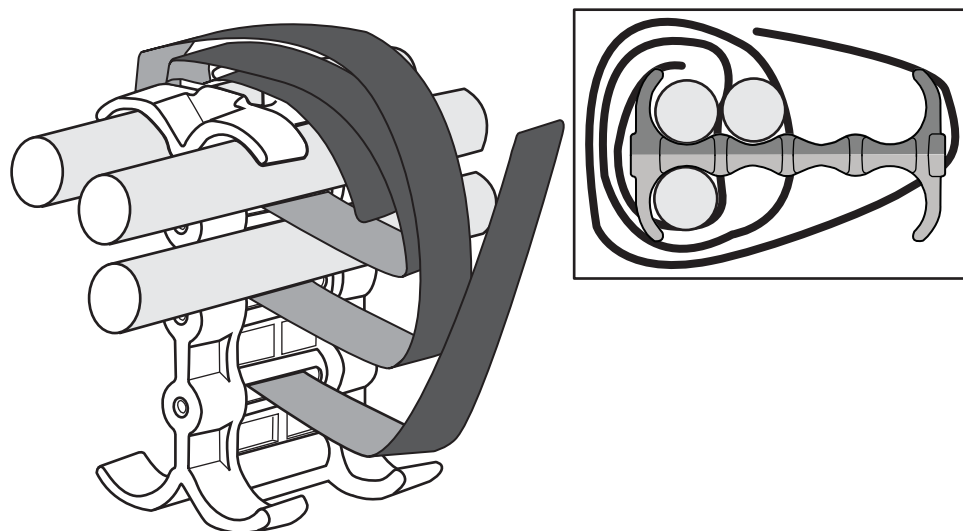

Cable cinch with four mRJ21 cables

Four mRJ21 cables may be secured as shown in [Figure 94](#).

FIGURE 94 Four mRJ21 cables

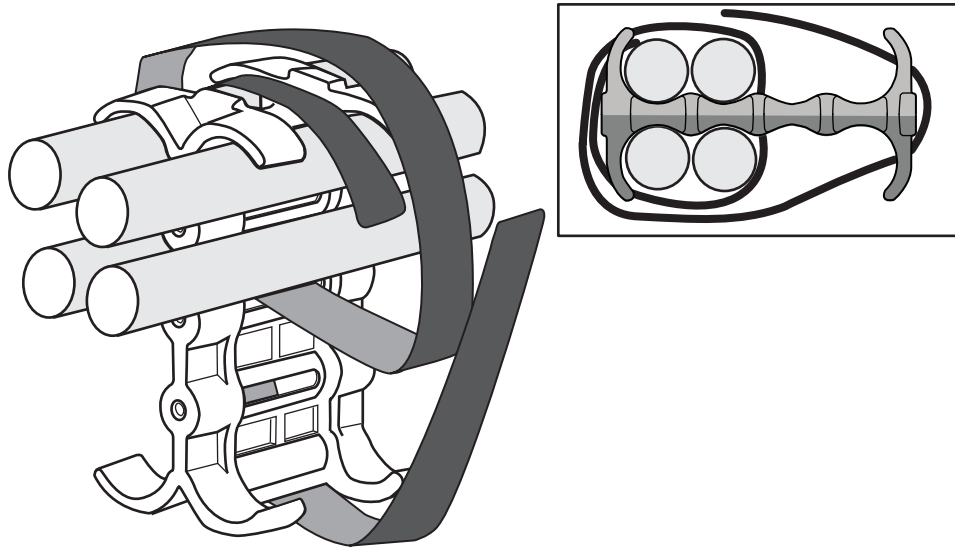

Cable cinch with five mRJ21 cables

Five mRJ21 cables may be secured as shown in [Figure 95](#).

FIGURE 95 Five mRJ21 cables

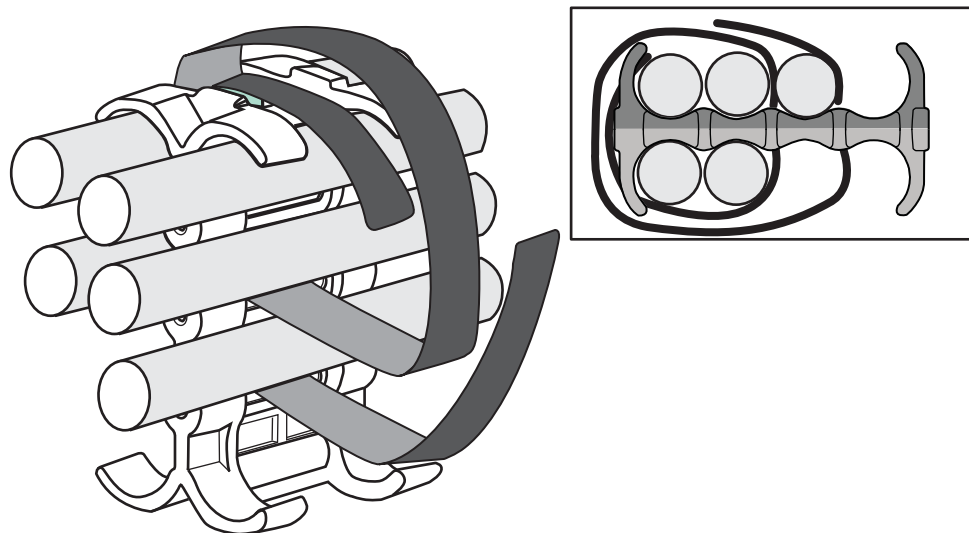

Cable cinch with six mRJ21 cables

Six mRJ21 cables may be secured as shown in [Figure 96](#).

FIGURE 96 Six mRJ21 cables

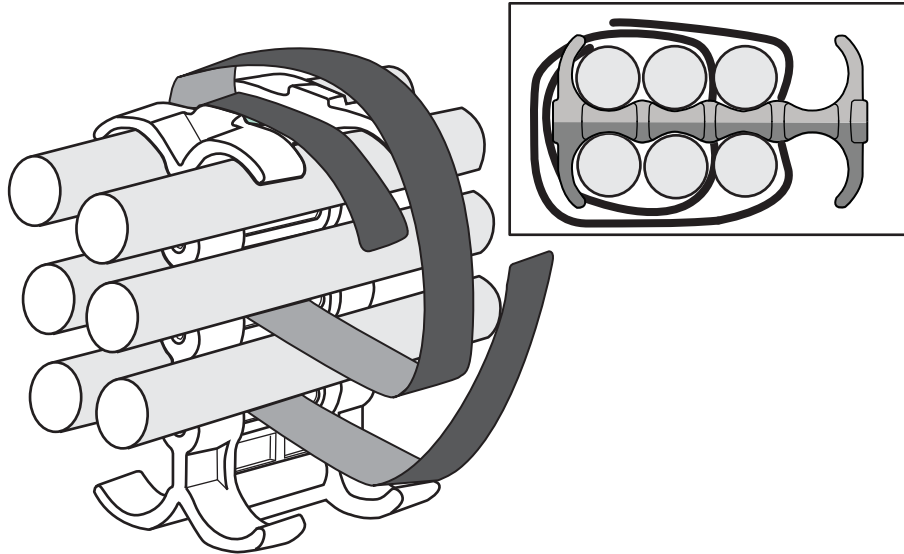

Cable cinch with seven mRJ21 cables

Seven mRJ21 cables may be secured as shown in [Figure 97](#).

FIGURE 97 Seven mRJ21 cables

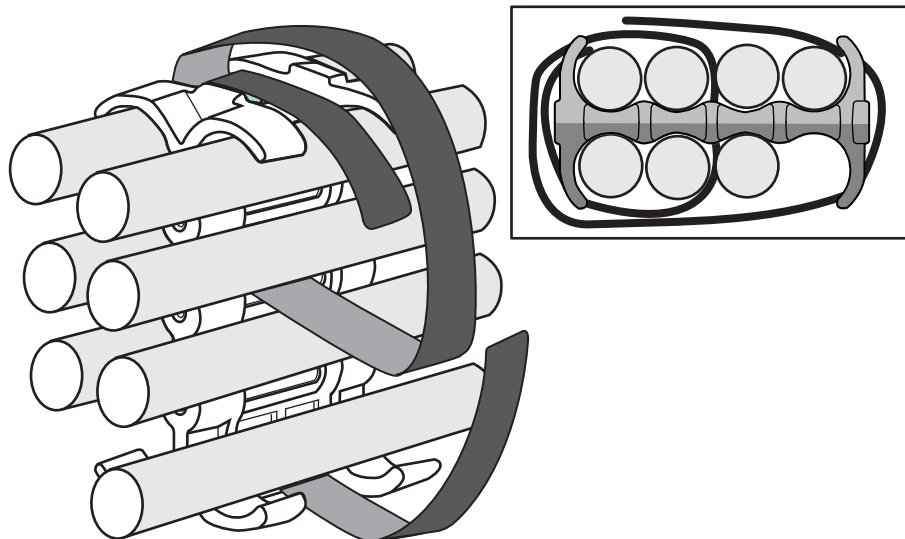

Cable cinch with eight mRJ21 cables

Eight mRJ21 cables may be secured as shown in [Figure 98](#).

FIGURE 98 Eight mRJ21 cables

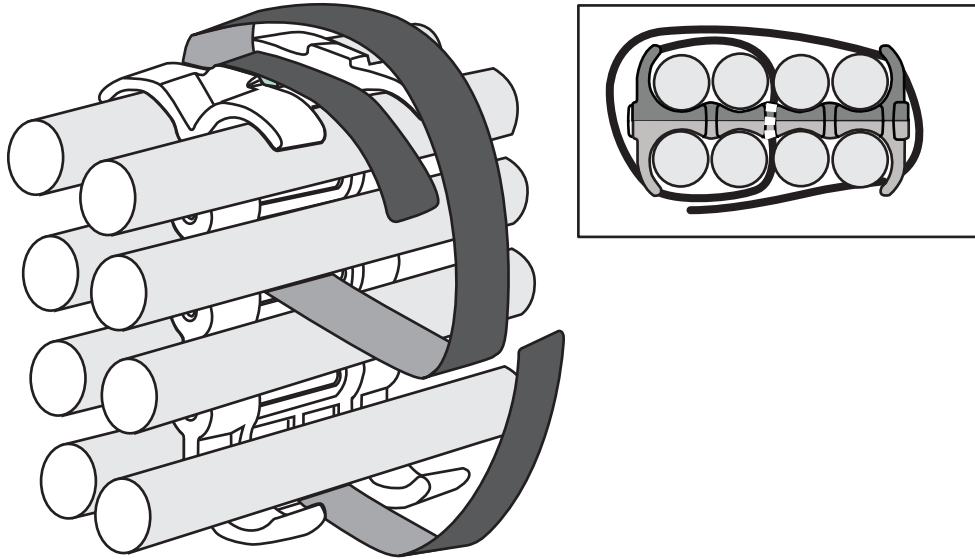

RJ45 procedures

Use the following guidelines when using the cable cinch clips with RJ45 cables.

Cable cinch with one group of RJ45 cables

RJ45 cables may be secured in groups of six. To secure up to six RJ45 cables in one group, place the Velcro strap through slot one and use the front left recesses as shown in [Figure 99](#).

FIGURE 99 One group of RJ45 cables

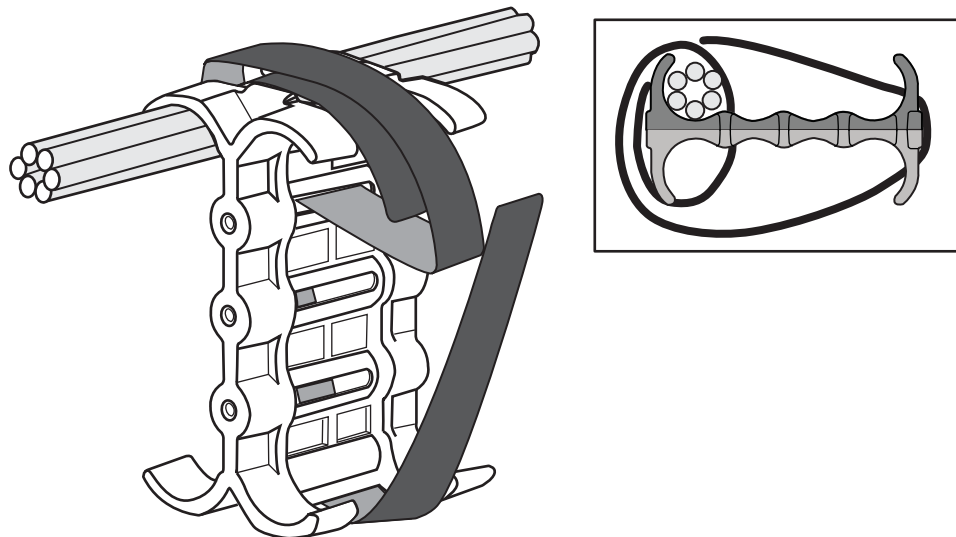

Cable cinch with two groups of RJ45 cables

12 RJ45 cables, in two groups, may be secured as shown in [Figure 100](#).

FIGURE 100 12 RJ45 cables in two groups

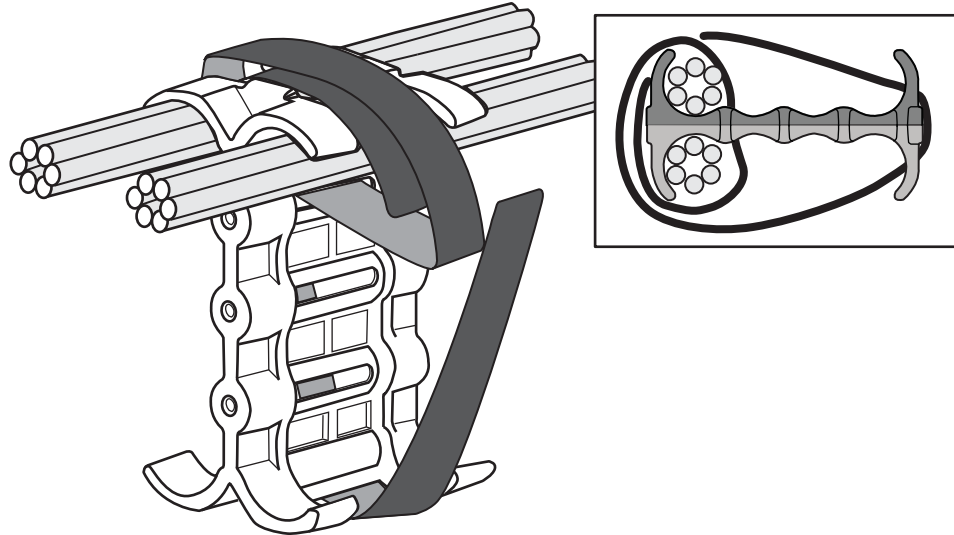

Cable cinch with three groups of RJ45 cables

18 RJ45 cables, in three groups, may be secured as shown in [Figure 101](#).

FIGURE 101 18 RJ45 cables in three groups

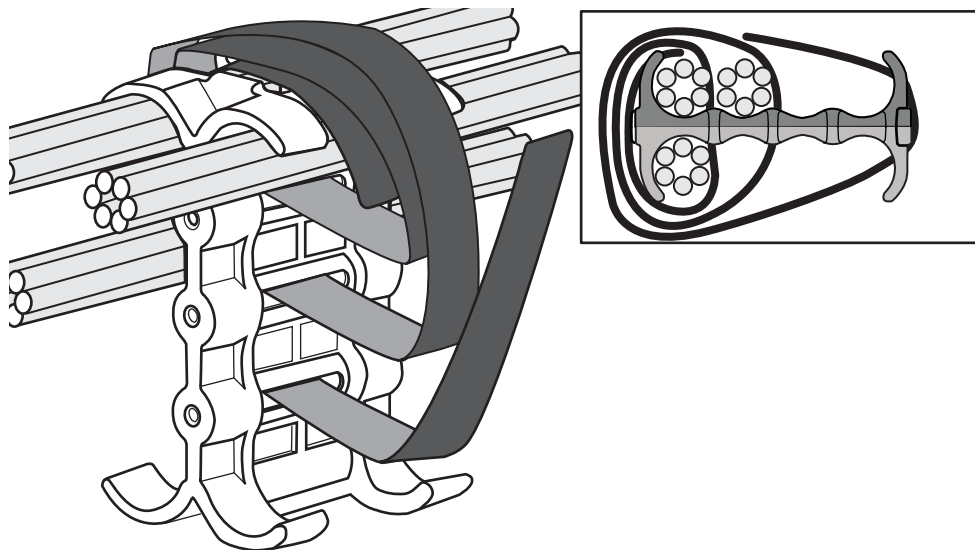

Cable cinch with four groups of RJ45 cables

24 RJ45 cables, in four groups, may be secured as shown in [Figure 102](#).

FIGURE 102 24 RJ45 cables in four groups

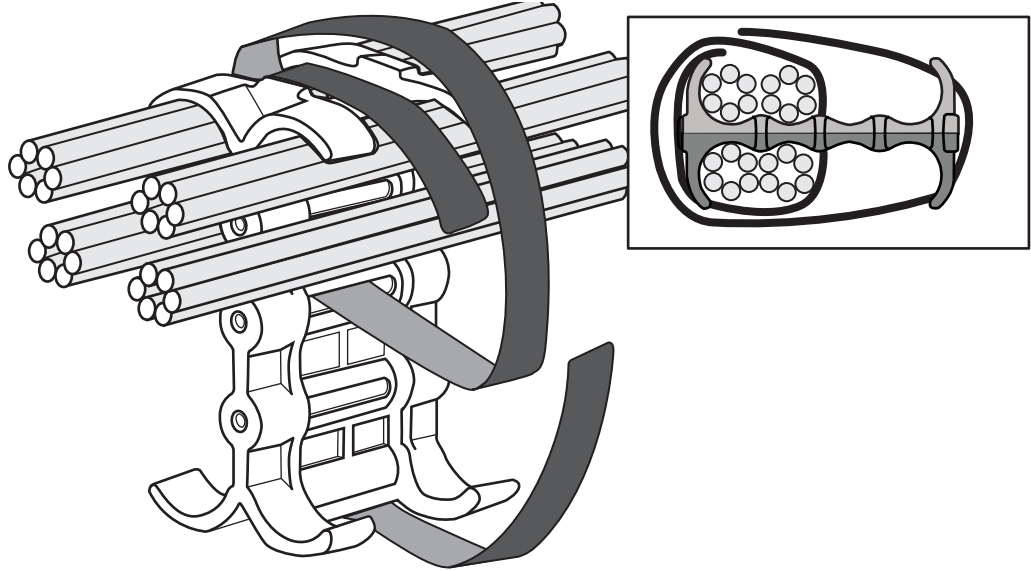

Cable cinch with five groups of RJ45 cables

30 RJ45 cables, in five groups, may be secured as shown in [Figure 103](#).

FIGURE 103 30 RJ45 cables in five groups

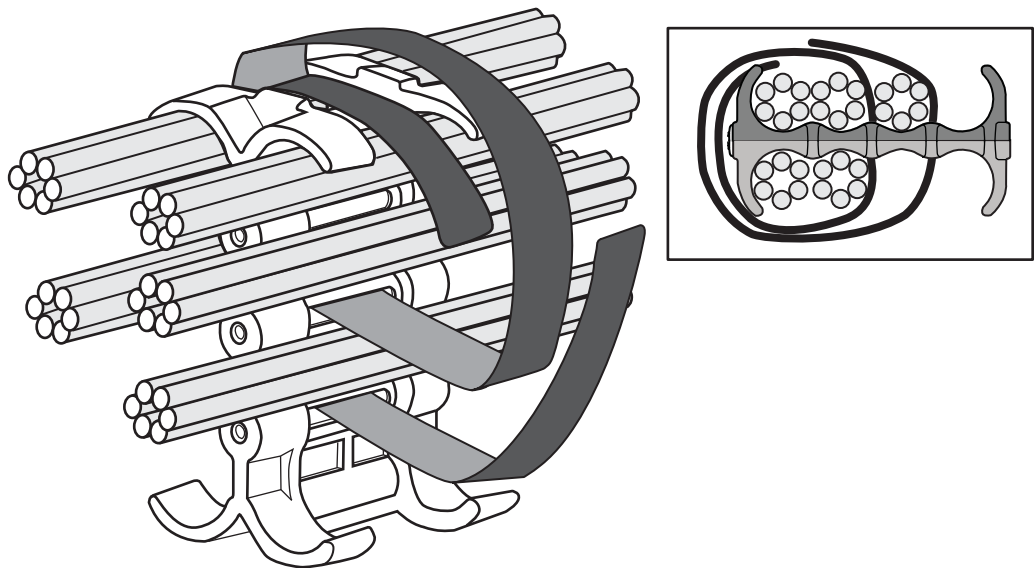

Cable cinch with six groups of RJ45 cables

36 RJ45 cables, in six groups, may be secured as shown in [Figure 104](#).

FIGURE 104 36 RJ45 cables in six groups

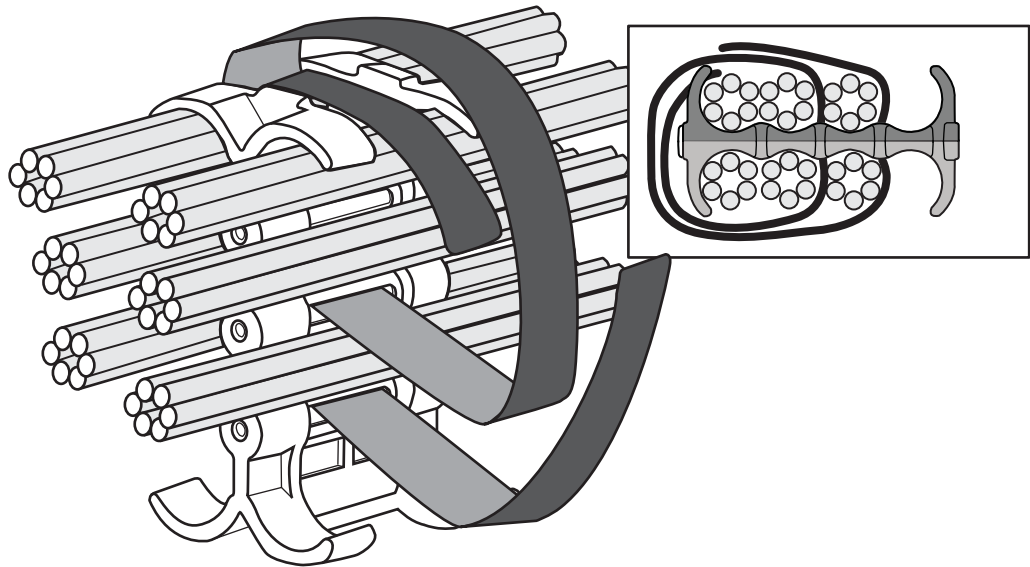

Cable cinch with seven groups of RJ45 cables

42 RJ45 cables, in seven groups, may be secured as shown in [Figure 105](#).

FIGURE 105 42 RJ45 cables in seven groups

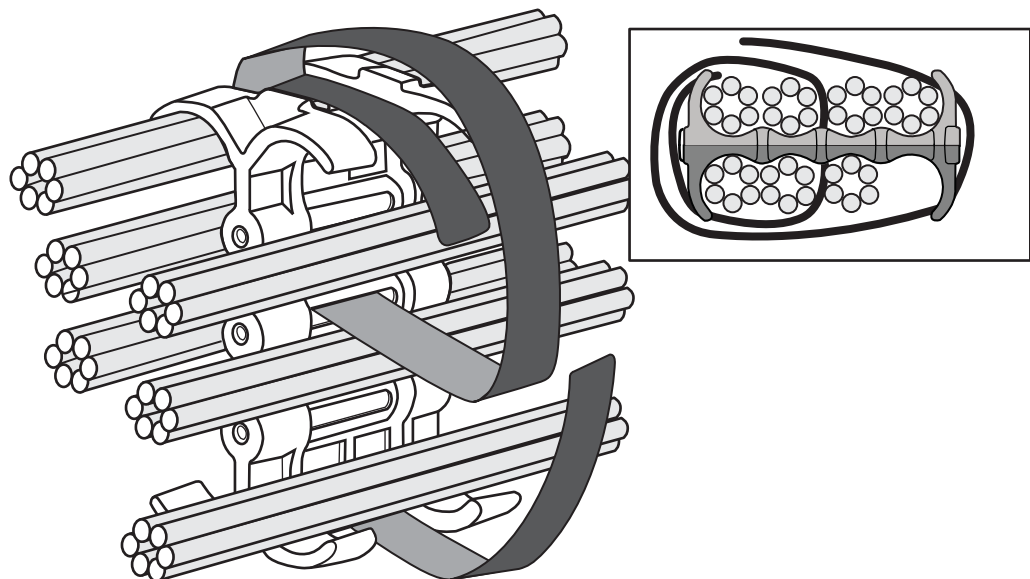

Cable cinch with eight groups of RJ45 cables

48 RJ45 cables, in eight groups, may be secured as shown in [Figure 106](#).

FIGURE 106 48 RJ45 cables in eight groups

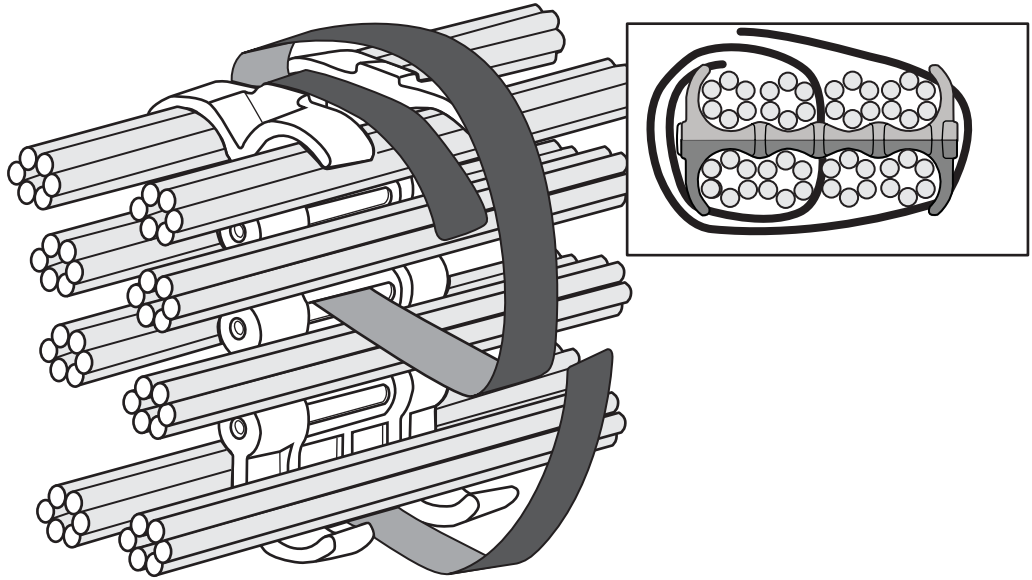

3 RJ45 procedures

Connecting a Router to a Network Device

Assigning permanent passwords



DANGER

The procedures in this manual are for qualified service personnel.

By default, the CLI is not protected by passwords. To secure CLI access, it is strongly recommended that you assign passwords.

The CLI contains the following access levels:

- **Privileged EXEC** – This level is also called the Enable level and can be secured by a password. From this level you can manage files on the management module flash memory or a auxiliary flash card in the management module slots 1 or 2, save the system configuration to flash memory, and clear caches.
- **CONFIG** – The configuration level. From this level you can configure a system IP address and configure routing features. To access the CONFIG mode, you must already be logged into the Privileged level of the EXEC mode.

NOTE

You cannot assign a password using the Web management interface. You can assign passwords using the Brocade Network Advisor software if an Enable password for a super user is already configured on the device.

You can set the following levels of Enable passwords:

- **Super user** – Allows complete read-and-write access to the system. This is generally for system administrators and is the only password level that allows you to configure passwords.

NOTE

You must set a super-user password before you can set other types of passwords.

- **Port configuration** – Allows read-and-write access for specific ports but not for global (system-wide) parameters.
- **Read only** – Allows access to the Privileged EXEC mode and CONFIG mode but only with read access.

To set passwords, perform the following steps:

1. At the opening CLI prompt, enter **enable** to change to the Privileged level of the EXEC mode.

```
Brocade enable
Brocade#
```

2. Access the CONFIG level of the CLI by entering the **configure terminal** command.

```
Brocade# configure terminal
Brocade(config)#
```

Syntax: configure terminal

3. Enter the **enable super-user-password** command to set the super-user password.

```
Brocade(config)# enable super-user-password mustang
```

Syntax: enable super-user password text

NOTE

You must set the super-user password before you can set other types of passwords.

4. Enter the following commands to set the port configuration and read-only passwords.

```
Brocade(config)# enable port-config-password mustang
```

```
Brocade(config)# enable read-only-password mustang
```

NOTE

If you forget your super-user password, see the *Multi-Service IronWare Software Release 05.2.00 for Brocade MLX Series and Brocade NetIron Family*.

Syntax: enable | super-user-password | read-only-password | port-config-password text

The text for the **read-only-password** and the **port-config password** should be different from the text for the **super-user** password. Passwords can be up to 48 characters long.

Configuring IP addresses

Brocade routers implement separate data and control planes. This architecture affects how you assign IP addresses. [Table 27](#) outlines the interfaces to which you can assign IP addresses.

In this table, “In band” refers to an interface over which user packets are routed, while “Out of band” refers to an interface over which control packets related to system management are forwarded.

TABLE 27 Interfaces that can be given IP addresses

Interface	Associated physical port	Out of band or In band
Management interface	Ethernet 10/100/1000 port on active or redundant management module	Out of band
Any interface over which user packets are routed	Any interface module port	In band
Any virtual interface over which user packets are routed	Any interface port	In band
Loopback interface	-	In band

Support of subnet masks

Brocade routers support both classical IP network masks (Class A, B, and C subnet masks, and so on) and Classless Interdomain Routing (CIDR) network prefix masks.

- Enter a classical network mask in IP address format. For example, enter “209.157.22.99 255.255.255.0” for an IP address with a Class-C subnet mask.
- To enter a prefix number for a network mask, enter a forward slash (/) and the number of bits in the mask immediately after the IP address. For example, enter “209.157.22.99/24” for an IP address that has a network mask with 24 significant (“mask”) bits.

Assigning an IP address to a management interface

Instead of assigning a global IP address to the router for system management purposes, you must assign an IP address to the active management module. If the active management module becomes unavailable and the redundant module becomes the active module, the IP address is automatically assigned to the new active management module.

For example, to assign the IP address 10.0.1.1 to the management module, use these steps.

1. At the opening CLI prompt, enter **enable**.

```
Brocade# enable
```

2. Enter the **erase startup-config** command at the Privileged EXEC level prompt (for example, Brocade#), then press **Enter**. This command erases the factory test configuration if it is still present.

```
Brocade# erase startup-config
```

Syntax: **erase startup-config**

After entering this command, perform a reload on the system.



CAUTION

Use the **erase startup-config** command only for new systems. If you enter this command on a system you have already configured, the command erases the configuration. If you accidentally erase the configuration on a configured system, enter the write memory command to save the running configuration to the startup-config file.

3. Access the configuration level of the CLI by entering the **configure terminal** command.

```
Brocade# configure terminal
Brocade(config)#
```

4. Configure the IP address and mask for the management interface by entering these commands.

```
Brocade(config)# interface management 1
Brocade(config-if-mgmt-1)# ip address 10.0.1.1 255.255.255.0
```

Syntax: **enable** [*password*]

Syntax: **configure terminal**

Syntax: **interface management** *num*

Syntax: [**no**] **ip address** *ip-addr ip-mask*

or

Syntax: [no] ip address *ip-addr/mask-bits*

Assigning IP addresses to an interface, virtual interface, or loopback interface

You must assign an IP address to each interface and virtual interface over which user packets are routed. You can also assign an IP address to a loopback interface, which is generally used for testing and diagnostic purposes.

You must use the serial connection to assign the first IP address. For subsequent addresses, you can also use the CLI through Telnet or the Web management interface. Use Brocade Network Advisor to assign IP addresses to virtual routing interfaces only.

By default, you can configure up to 24 IP addresses on each interface, virtual interface, and loopback interface.

For example, to assign the IP address 192.22.3.44 and subnet mask 255.255.255.0 to Ethernet interface 1/1, do the following.

1. At the opening CLI prompt, enter **enable**.

```
Brocade# enable
```

2. Enter the following command at the Privileged EXEC level prompt, then press **Enter**. This command erases the factory test configuration if it is still present.

```
Brocade# erase startup-config
```

After you enter this command, you will need to restart the system.



CAUTION

Use the erase startup-config command only for new systems. If you enter this command on a system you have already configured, the command erases the configuration. If you accidentally erase the configuration on a configured system, enter the write memory command to save the running configuration to the startup-config file.

3. Access the configuration level of the CLI by entering the following command.

```
Brocade# configure terminal  
Brocade(config)#
```

4. Configure the IP address and subnet mask for Ethernet interface 1/1 by entering the following commands.

```
Brocade(config)# interface ethernet 1/1  
Brocade(config-if-e10000-1/1)# ip address 192.22.3.44 255.255.255.0
```

Syntax: enable [*password*]

Syntax: configure terminal

Syntax: [no] ip address *ip-addr ip-mask* [**secondary**]

or

Syntax: [no] ip address *ip-addr/mask-bits* [**secondary**]

Use the **secondary** parameter if you have already configured an IP address within the same sub-net on the interface.

Enabling and disabling the interfaces

By default, all router interfaces are disabled. To enable an interface, enter the **enable** command at the appropriate interface configuration level of the CLI. For example, to enable the management interface, enter the **enable** command at the management interface configuration level of the CLI.

```
Brocade(config-if-mgmt-1)# enable
```

Syntax: enable

You can disable each of these interfaces using the **disable** command at the appropriate interface configuration level of the CLI. For example, to disable the management port, enter the **disable** command at the management interface configuration level of the CLI.

```
Brocade(config-if-mgmt-1)# disable
```

Syntax: disable

Understanding management port functions

The management port performs specific functions and is subject to some limitations, as described.

- Because the management port allows you to configure, monitor, and manage routers only, this port has the same limited functionality as an IP host port.
- You cannot enable and run routing protocols on the management port.
- You cannot configure routes from the management interface.
- The management port uses static IP routes from the interface routing tables.
- If you configure the redistribution of static or directly connected routes for a particular routing protocol, the protocol redistributes routes associated with the interface module ports, but not the routes associated with the management port.

To display configuration information and statistics about the management port, enter the **show interface management 1** command at any CLI level.

Connecting the router to a network device

You can connect a router to another Ethernet network device. Brocade MLXe Series routers support connections to other vendors' devices as well as Brocade network devices.

The Ethernet interface modules available with Brocade MLXe Series are described in "[Interface modules](#)" on page 13. These include XFP fiber, SFP and SFP+ fiber, and RJ45 copper interfaces. Details regarding the SFP, SFP+, and XFP fiber-optic transceivers supported for these interface modules are also described.

To connect a router to another network device, you must do the following.

- Install the fiber-optic modules if required.
- Cable the modules with either copper cable or fiber-optic cable as required.

The following sections provide information about module installation and cabling, as well as how to clean fiber-optic connectors and troubleshoot network connections.

Installing a fiber-optic transceiver

To connect a router to another network device using a fiber port, install a fiber-optic transceiver (SFP, SFP+, or XFP, as required by your interface module).



DANGER

All fiber-optic interfaces use Class 1 Lasers.

NOTE

Refer to “[Installation precautions](#)” on page 40 for other hardware installation precautions.

Before installing a fiber-optic transceiver, have on hand an ESD wrist strap with a plug for connection to the ESD connector on the router chassis.



DANGER

For safety reasons, the ESD wrist strap should contain a 1 megohm series resistor.

Follow these steps to install a fiber-optic transceiver.

1. Put on the ESD wrist strap and ground yourself by inserting the plug into the ESD connector on the router chassis.
2. Remove the transceiver from the protective packaging.
3. Remove the metal cover from the port on the interface module.
4. Gently insert the fiber-optic transceiver into the port until the transceiver clicks into place. Transceivers are keyed to prevent incorrect insertion.

Cabling a fiber-optic transceiver

Follow these steps to cable a fiber-optic transceiver.

1. Remove the protective covering from the fiber-optic port connectors and store the covering for future use.
2. Before cabling a fiber-optic transceiver, it is strongly recommended that you clean the cable connectors and the port connectors. For more information, refer to “[Cleaning fiber-optic ports and connectors](#)”.
3. Gently insert the two cable connectors (a tab on each connector should face upward) into the ports until the tabs lock into place.

Tunable 10 GbE DWDM SFP+

NOTE

Tunable 10 GbE DWDM SFP+ are only supported on MLX8x10, MLX24x10 modules

The tunable 10 GbE dense wavelength-division multiplexing (DWDM) SFP+ modular optic (part number 10G-SFPP-ZRD-T) can be configured through the CLI to use C-band channels 1 - 102 for flexible metro or campus Ethernet links that reach up to 80 km.

For 10-Gigabit Ethernet DWDM interfaces only, configure full C-band tunable optics as shown below.

To configure a physical port, enter a command such as the following.

```
Brocade(config-if-e10000-1/1)# tunable-optic sfpp channel 5
```

Syntax: `tunable-optic sfpp channel <channel number> [show]`

To configure a LAG port, enter a command such as the following.

```
Brocade(config-if-e10000-1/1)# physical-port 1/1 tunable-optic sfpp channel 5
```

```
Brocade(config-lag-lag1)# physical-port 1/1 tunable-optic sfpp channel 5 show  
Channel 5: 191.3THz, 1567.13nm
```

Syntax: `physical-port <port> tunable-optic sfpp channel <channel number> [show]`

Use the **channel number** parameter to specify the channel number to use on the interface. Possible values 0 through 102.

Use the **show** options to display the SFPP channel used on the interface.

Cleaning fiber-optic ports and connectors

To avoid problems with connections between fiber-optic ports and fiber cable connectors, it is strongly recommended that you clean ports and connectors each time you make a connection. Dust can accumulate inside the port and connector and cause problems as serious as reducing the optic launch power.

To clean the fiber-optic ports and cable connectors, it is recommended that you use a fiber-optic reel-type cleaner. You can purchase this type of cleaner from the following website:

<http://www.fisfiber.com/>

When you are not using a fiber-optic transceiver port, always replace the protective cover.

Troubleshooting network connections

Observe connection LEDs to determine if network connections are functioning properly. [Table 28](#) lists the LEDs related to the network connections, the desired state of each LED, possible abnormal states of each LED, and what to do if an LED indicates an abnormal state.

4 Testing network connectivity

TABLE 28 Network connection-related LED states

LED	Desired state	Meaning	Abnormal state	Meaning or action
Interface module				
Link	On	A link is established with the remote port.	Off	A link is not established with the remote port. Try the following: <ul style="list-style-type: none">• Verify that the connection to the other network device has been properly made, and that the other network device is powered on and operating correctly.• Verify that the transmit port on a router is connected to the receive port on the other network device, and that the receive port on the router is connected to the transmit port on the other network device. If you are not certain, remove the two cable connectors and reinsert them in the port connector, reversing their order.• Dust may have accumulated in the cable connector or port connector. For information about cleaning the connectors, refer to “Cleaning fiber-optic ports and connectors” on page 147.• If these actions do not resolve the problem, try using a different port or a different cable.
Active	On or blinking	The port is transmitting and receiving user packets.	Off for an extended period.	The port is not transmitting or receiving user packets. Try the following: <ul style="list-style-type: none">• Check the Link LED to make sure the link is still established with the remote port. If not, take the actions described in the Meaning or Action column for the Link LED.• Verify that the port has not been disabled through a configuration change. You can use the CLI. If you have configured an IP address on the device, you also can use the Web management interface or Brocade Network Advisor.

If a problem persists after taking these actions, contact Brocade Technical Support.

Testing network connectivity

After you cable the fiber-optic transceivers, you can test connectivity to other network devices by pinging those devices. You also can perform traceroutes.

Pinging an IP address

To verify that the router can reach another device through the network, enter a command such as the following at any level of the CLI.

```
Brocade# ping 192.33.4.7
```

Syntax: `ping ip addr | hostname [source ip addr] [count num] [timeout msec] [ttl num] [size byte] [quiet] [numeric] [no-fragment] [verify] [data 1-to-4 byte hex] [brief]`

NOTE

If you send the ping to the IP broadcast address, the device lists the first four responses to the ping.

Tracing a route

To determine the path through which the router can reach another network device, enter a command such as the following at any level of the CLI.

```
Brocade# traceroute 192.33.4.7
```

Syntax: **traceroute** *host-ip-addr* [*maxttl value*] [*minttl value*] [*numeric*] [*timeout value*]
[*source-ip ip addr*]

The CLI displays **traceroute** information for each hop on the route as soon as the information is received. **Traceroute** requests display all responses to a given TTL. If there are multiple equal-cost routes to the destination, the router displays up to three responses by default.

4 Testing network connectivity

Managing Routers and Modules

Managing the device

You can perform these management tasks for the router:

- Enable and disable a DC power source, if necessary.
- Display status and temperatures of all hardware components.
- Display the Syslog configuration and static and dynamic buffers.
- Disable and re-enable power to interface modules.

Disabling and re-enabling power to interface modules

You can disable power and re-enable power to all interface modules, or to a specified interface module using the **power-off** command in the CLI, as shown in the following example:

```
Brocade# power-off lp all
```

Syntax: **power-off lp** [**all** | *slot-number*]

- **all** - disables power to all interface modules
- *slot number* - disables power to the interface module in the specified slot. You can specify 1-4 for 4-slot routers, 1-8 for 8-slot routers, 1-16 for 16-slot routers, and 1-32 for 32-slot routers.

NOTE

It is recommended that you do not disable power to interface modules during a software upgrade. If you try to disable power during a software upgrade, the following message will be displayed:

```
Warning: There is an outstanding software download.  
Do you want to continue ? (enter "y" or "n")
```

Type "**n**" and wait until the upgrade is complete.

To re-enable power to all interfaces or to a specific interface, enter the **power-on lp** command, as shown in this example:

```
Brocade# power-on lp
```

Syntax: **power-on lp** [**all** | *slot-number*]

- **all** - enables power to all interface modules
- *slot-number* disables power to the interface module in the specified slot. You can specify 1-4 for 4-slot routers, 1-8 for 8-slot routers, 1-16 for 16-slot routers, and 1-32 for 32-slot routers.

Monitoring I2C failures on management modules

The management module accesses temperature sensors, fan controllers, power supplies, serial PROMs, and other devices are all accessed through the I2C serial bus. When I2C devices are inaccessible, generic (and uninformative) error messages are displayed on the management module console interface. If you do not keep a record of the console messages before the management module resets or reloads, these error messages will be lost.

At the first occurrence of an I2C failure, the Global I2C Error Indicator (GIEI) flag severity is set to major. The GIEI flag is cleared only when the management module is able to access the same physical device successfully. The GIEI severity flag is set to minor only if other I2C devices are accessible. A set of static and dynamic Syslog messages are generated when any or all of the following events occur:

- When an I2C failure is first detected
- When the GIEI severity is changed from major to minor
- When the GIEI flag is cleared

These Syslog messages are generated in both the static and dynamic sections of the **show logging** command output. A Syslog message is also sent to the SNMP log server.

When the GIEI is set to major, the first Syslog message displayed is an Alert. The following example shows an Alert Syslog message where the GIEI is set to major:

```
Brocade# show logging
Sysloglogging: enabled (0 messages dropped, 0 flushes, 1 overruns)
Buffer logging: level ACDMEINW, 50 messages logged
level code: A=alert C=critical D=debugging M=emergency E=error
I=informational N=notification W=warning

Static Log Buffer:
Apr 16 18:21:25:A:System: Power Supply 2 , middle, Not Installed (FAILED)
Apr 16 18:21:25:A:System: Power Supply 3 , top, Not Installed (FAILED)
Apr 16 18:21:25:A:System: bad i2c access (GIEI = set), Severity Major, Mux
index 0, Muxtap 4, ID 0x4, Addr0x5, (FANTRAY4)
Apr 16 18:21:25:I:System: last good i2c access, Muxindex 0, Muxtap 1, ID
0x9, Addr0x1, (SNM1TEMP)

Dynamic Log Buffer (50 lines):
Apr 16 18:21:25:A:System: bad i2c access (GIEI = set), Severity Major, Mux
index 0, Mux tap 4, ID 0x4, Addr 0x5, (FANTRAY4)
Apr 16 18:21:25:I:System: last good i2c access, Mux index 0, Mux tap 1, ID
0x9, Addr 0x1, (SNM1TEMP)
Mar 28 12:36:47:A:System: Set fan speed to MED (75%)
Mar 25 21:40:47:A:System: Set fan speed to MED-HI (90%)
```

The Syslog message shows the last successful I2C access by the management module and also contains the following information about the failed device:

- Current state of the GIEI flag
- Severity of the failure: major or minor
- MUX index number:
 - 0-1 - there are total of 2 MUX indexes in Brocade NetIron XMR 32000 and Brocade MLX-32 devices.
 - The MUX index is always zero in 4-, 8-, and 16-slot Brocade NetIron XMR or Brocade MLX devices
- MUX tap number:
 - 0-7 - there are total of 8 MUX taps connected to a MUX device.
 - 15 - MUX tap is non applicable
- Device ID
- Device address
- Description of the load

If the GIEI severity changes from the time the GIEI is set to major, the first Syslog message in the static section of the log is updated to reflect this change. A copy of this updated message is generated in the dynamic section of the log and a copy is sent to SNMP log server.

When an I2C failure is first detected, a second Syslog message is generated containing information about the last successful I2C access before the GIEI error flag was set. The last successful access information remains unchanged until the GIEI is cleared. A copy of the second Syslog message is also sent to the SNMP log server.

The second Syslog message is always displayed as an informational Syslog. The following example shows an informational Syslog message:

```
Brocade# show logging
Syslog logging: enabled (0 messages dropped, 0 flushes, 1 overruns)
Buffer logging: level ACDMEINW, 50 messages logged
level code: A=alert C=critical D=debugging M=emergency E=error
I=informational N=notification W=warning
Static Log Buffer:
Apr 16 18:21:25:A:System: Power Supply 2 , middle, Not Installed
(FAILED)
Apr 16 18:21:25:A:System: Power Supply 3 , top, Not Installed (FAILED)
Apr 16 18:22:12:I:System: i2c recovered (GIEI = clear), Severity Minor,
Mux index 0, Mux tap 4, ID 0x4, Addr 0x5, (FANTRAY4)

Dynamic Log Buffer (50 lines):
Apr 16 18:22:12:I:System: i2c recovered (GIEI = clear), Severity Minor,
Mux index 0, Mux tap 4, ID 0x4, Addr 0x5, (FANTRAY4)
Apr 16 18:21:27:I:System: bad i2c access (GIEI = set), Severity Minor,
Mux index 0, Mux tap 4, ID 0x4, Addr 0x5, (FANTRAY4)
Apr 16 18:21:25:A:System: bad i2c access (GIEI = set), Severity Major,
Mux index 0, Mux tap 4, ID 0x4, Addr 0x5, (FANTRAY4)
Apr 16 18:21:24:I:System: last good i2c access, Mux index 0, Mux tap 1,
ID 0x9, Addr 0x1, (SNM1TEMP)
```

When the GIEI flag is cleared, the first Syslog message in the static section of the log is updated to show that the GIEI is set to clear. The second Syslog message in the static section is removed. A copy of the updated first Syslog message is also generated in the dynamic section of the log and in SNMP log server.

When a problematic device is removed from the system, the GIEI is cleared and all Syslog messages are updated to show that the GIEI is set to clear.

5 Managing the device

If an I2C failure has not occurred, there will be no I2C messages in the static log, dynamic log, or SNMP log server. The following example shows output from the **show logging** command when there is no I2C failure.

```
Brocade# show logging
Syslog logging: enabled (0 messages dropped, 0 flushes, 1 overruns)
Buffer logging: level ACDMEINW, 50 messages logged
level code: A=alert C=critical D=debugging M=emergency E=error
I=informational N=notification W=warning
Static Log Buffer:
Apr 16 18:21:25:A:System: Power Supply 2 , middle, Not Installed (FAILED)
Apr 16 18:21:25:A:System: Power Supply 3 , top, Not Installed (FAILED)
Dynamic Log Buffer (50 lines):
Mar 28 12:36:47:A:System: Set fan speed to MED (75%)
Mar 25 21:40:47:A:System: Set fan speed to MED-HI (90%)
Mar 25 16:30:47:A:System: Set fan speed to MED (75%)
Mar 23 23:12:07:A:System: Set fan speed to MED-HI (90%)
```

If the system detects a major I2C failure, the system prevents the management module from accessing devices through the I2C serial bus. The output from the **show chassis** command and the **show temperature** command reflect this action, as shown in these examples.

```
Brocade# show chassis
*** Note: ***
*** Global I2C Error Indicator is set (severity: Major). ***
*** All I2C access are skipped. ***
*** Brocade MLX-4 device ***
---POWERS ---
Slot Power-On Priority and Power Usage:
Slot2 pri=1 module type=NI-MLX-1Gx20-GC 20-port 10/100/1000 Copper Module power
usage=146W
Slot4 pri=1 module type=NI-X-OC48x4 4-port OC48/12 STM16/STM4 Module power
usage=132W
---FANS ---
---TEMPERATURE READINGS ---
LP2 Sensor1: 34.500C
LP2 Sensor2: 44.125C
```

The following output is from the **show temperature** command with the GIEI set to major severity.

```
Brocade# show temperature
*** Note: ***
*** Global I2C Error Indicator is set (severity: Major). ***
*** All I2C access are skipped. ***
SLOT #: CARD TYPE: SENSOR # TEMPERATURE (C):
2 LP 1 34.0C
2 LP 2 44.250C
4 LP 1 36.0C
4 LP 2 45.750C
```

Displaying device status and temperature readings

You can display the following information about the router:

- Power-on priority of the device slots
- Status of the fans
- Temperature readings of the management, switch fabric, interface, and fan control modules and the interval at which the system reads the temperature of these modules
- MAC address of the device

To display this information, enter the **show chassis** command at any level of the CLI.

```

Brocade# show chassis
*** Brocade MLX-4 chassis ***
---POWERS ---
Power 1 (32011000 - AC 1200W): Installed (OK)
Power 2: not present
Power 3: not present
Total power budget for device = 1200 W
Total power used by system core = 183 W
Total power used by LPs = 386 W
Total power available = 631 W
Slot Power-On Priority and Power Usage:
Slot1 pri=1 module type=NI-MLX-1Gx20-GC 20-port 10/100/1000 Copper Module power
usage=156W
Slot4 pri=1 module type=NI-X-OC48x8 8-port OC48/12 STM16/STM4 Module power
usage=230W
--- FANS ---
right fan tray (fan 1): Status = OK, Speed = MED-HI (90%)
right fan tray (fan 2): Status = OK, Speed = MED-HI (90%)
--- TEMPERATURE READINGS ---
Active Mgmt Module: 36.500C 49.625C
Standby Mgmt Module: 36.250C 51.0C
SNM1: 37.0C
SNM2: 38.0C
SNM3: not present
LP1 Sensor1: 41.5C
LP1 Sensor2: 50.625C
LP4 Sensor1: 39.0C
LP4 Sensor2: 49.250C
LP4 Sensor3: UNUSED
LP4 Sensor4: 38.5C
LP4 Sensor5: 47.750C
LP4 Sensor6: UNUSED
Fans are in auto mode. Temperature Monitoring Poll Period is 60 seconds

```

[Table 29](#) describes the **show chassis** command output.

TABLE 29 **show chassis** command output

Field	Description
Powers	
Power <i>num</i> , <i>part num</i>	The Power <i>num</i> is the power supply number as positioned in the device. The number of power supplies are as follows: 4-slot devices: 1 – 3 8-slot devices: 1 – 4 16-slot devices: 1 – 8 32-slot devices: 1 – 8 The <i>part num</i> is the part number of the power supply purchased. This applies to AC and DC power supplies.

TABLE 29 show chassis command output (Continued)

Field	Description
Power status	<p>Indicates whether an AC or DC power supply is installed in the specified power supply slot and the status of the power supply, which can be one of the following:</p> <ul style="list-style-type: none"> • Installed (Shutdown)-The power supply has shut down. A power supply will shut down due to flapping, or if a shut down is enabled manually using the power-off power-supply command. Refer to “Enabling a power supply shutdown” on page 197. • Installed (OK) – The power supply is functioning properly and supplying power to the device and installed modules. • Failed – The power supply is not functioning and is not supplying power to the device and installed modules. • not present – There is no power supply installed in the slot. • Installed (Failed or Disconnected) - The power supply is not functioning, or the power supply is not connected to the device and installed modules.
Total power budget for device	The sum of all power (in watts), used by all power supplies currently functioning in the device. Refer to “Maximum power consumption for Brocade MLXe router components” on page 216.
Total power used by system core	The total power used by the management modules, switch fabric modules, and fans. Each component consumes different amounts of power.
Total power used by LPs	The total power used by the interface modules. Each module type consumes different amounts of power.
Total power available	The total power budget for the device minus the total power used by the system core and the installed interface modules.
Slot Power-On Priority	The configured power-on priority of each interface module.
Slot num	The slot <i>num</i> is the device slot number.
Slot1 – Slot16	The priority of each device slot as configured by the lp-slot-priority command.
4-slot device: Slot1 – Slot4	The priority can be 1 (low, default) – 8 (high). If the amount of power supplied to the device falls below a minimum threshold, the device slots with the lowest priority will likely lose power. For information about using the lp-slot-priority command, refer to “Changing priority of slots for interface modules” on page 175.
8-slot device: Slot1 – Slot8	
16-slot device: Slot1 – Slot16	
32-slot device: Slot1 – Slot32	
Fans	
Fan number	Information about fans in the device.
Status	<p>The fan status of a fan can be OK or Failed:</p> <ul style="list-style-type: none"> • OK – The fan is functioning properly and is keeping the temperature of each module within an acceptable range. • Failed – The fan is not working or the fan control module cannot control the fan.
Speed	<p>Fan speed can be one of four settings:</p> <ul style="list-style-type: none"> • Low – The fan is functioning at 50 percent of capacity. • Medium – The fan is functioning at 75 percent of capacity. • Medium-high – The fan is functioning at 90 percent of capacity. • High – The fan is functioning at 100 percent of capacity.
Temperature readings	
Active and Standby Mgmt Module	The temperature of the active and standby management modules.
Fan number	The temperature of fan0 and fan1.

TABLE 29 show chassis command output (Continued)

Field	Description
SNMnumber	The temperature of the switch fabric module.
LPnumber	The temperature of the interface module.
Temperature Monitoring Poll Period	The interval at which the system reads the temperature sensor on the management, switch fabric, interface, and fan control modules.
MAC address	
Backplane EEPROM MAC Address	The MAC address of the device.

Displaying the Syslog configuration and static and dynamic buffers

To display the Syslog parameters currently in effect on a device, enter the **show logging** command from any level of the CLI.

```
Brocade> show logging
Syslog logging: enabled (0 messages dropped, 0 flushes, 0 overruns)
  Buffer logging: level ACDMEINW, 7 messages logged
  level code: A=alert C=critical D=debugging M=emergency E=error
              I=informational N=notification W=warning
...
```

Syntax: show logging

[Table 30](#) describes the Syslog output buffer configuration information, in the rows above the log entries.

TABLE 30 Syslog buffer configuration

Field	Description
Syslog logging	The state (enabled or disabled) of the Syslog buffer.
messages dropped	The number of Syslog messages dropped due to user-configured filters. By default, the software logs messages for all Syslog levels. You can disable individual Syslog levels, in which case the software filters out messages at those levels. Each time the software filters out a Syslog message, this counter is incremented.
flushes	The number of times the Syslog buffer has been cleared by the clear logging command. For information about clearing the Syslog buffer, refer to “Static and dynamic buffers” on page 158.
overruns	The number of times the dynamic log buffer has filled up and been cleared to hold new entries. For example, if the buffer is set for 100 entries, the 101st entry causes an overrun. After that, the 201st entry causes a second overrun.
level	The message levels that are enabled. Each letter represents a message type and is identified by the key (level code) below the value. If you disable logging of a message level, the code for that level is not listed.
messages logged	The total number of messages that have been logged since the software was loaded.
level code	The message levels represented by the one-letter codes.

Static and dynamic buffers

The software provides a static buffer and a dynamic buffer:

- **Static** – logs power supply failures, fan failures, and temperature warning or shutdown messages
- **Dynamic** – logs all other message types. In previous releases, power supply messages were displayed in static logs only, with only the last event logged. Beginning with release 03.8.00, power supply messages are displayed in both static and dynamic logs.

In the static log, new messages replace older ones, so only the most recent message is displayed. For example, only the most recent temperature warning message will be present in the log. If multiple temperature warning messages are sent to the log, the latest one replaces the previous one. The static buffer is not configurable.

The message types that appear in the static buffer do not appear in the dynamic buffer. The dynamic buffer contains up to the maximum number of messages configured for the buffer (50 by default), then begins removing the oldest messages (at the bottom of the log) to make room for new ones.

The static and dynamic buffers are both displayed when you enter the **show logging** command.

```
Brocade(config)# show logging
...
Static Log Buffer:
Aug 27 12:42:42:A:Power Supply 6, 1st right, failed

Dynamic Log Buffer (50 lines):
Aug 27 12:19:04:I:Interface ethernet3/4, state up
Aug 27 12:19:04:I:Interface ethernet6/3, state up
Aug 27 12:19:04:I:Interface ethernet3/2, state up
Aug 27 12:19:04:I:Interface ethernet6/1, state up
Aug 27 12:19:00:N:Module up in slot 6
Aug 27 12:19:00:N:Module up in slot 3
Aug 27 12:18:43:I:Warm start
```

When you clear log entries, you can selectively clear the either buffer, or you can clear both. For example, to clear only the dynamic buffer, enter the **clear logging** command at the Privileged EXEC level.

```
Brocade# clear logging dynamic-buffer
```

Syntax: **clear logging** [**dynamic-buffer** | **static-buffer**]

Specify the **dynamic-buffer** keyword to clear the dynamic buffer, or the **static-buffer** keyword to clear the static buffer. If you do not specify a buffer, both buffers are cleared.

Managing switch fabric modules

This section provides information about how to manage standard switch fabric modules and high speed switch fabric modules.

NOTE

In CLI output, standard modules are referred to as generation 1 (G1) modules, and high-speed modules are referred to as generation 2 (G2) modules. The following interface modules are classified by the system as G2 modules: 8x10G, 100G modules. All other interface modules such as 4-port 10G, 2-port 10G, 20-port 1G, 24-port 1G, and 48-port 1G modules are classified by the system as G1 modules.

High speed switch fabric (HSF) modules can operate in Normal mode or Turbo mode. Standard switch fabric modules (SFM) can only operate in Normal mode. The HSF module is classified as a G2 module and SFM module is classified as a G1 module.

When operating in Normal mode, the system uses fixed size cells across the backplane. When operating in Turbo mode, the system uses variable size cells across the backplane. Turbo mode provides higher performance since it is a more efficient mechanism of sending cells across the backplane.

The system selects the operating mode for switch fabric modules at startup, or when the first switch fabric or interface module is installed. The system uses this mode for all modules that are subsequently installed. HSF modules will boot in Turbo mode only if all active interface modules are G2 modules. In a chassis loaded with G1 and G2 modules, the HSF modules will default to Normal mode.

NOTE

If a system is operating in Turbo mode, G1 interface modules are blocked from operation. The user has to change the switch fabric mode to Normal mode and restart the system before using the G1 interface modules.

If the system fabric mode is changed to Normal mode from Turbo mode, or vice versa, the system will not change the current operating mode unless the chassis is reloaded.

NOTE

Changes to the switch fabric operating mode do not take effect until after a system reload.

The switch fabric modes have the following restrictions:

- The system blocks discovery of any standard switch fabric (G1) module if you have issued the **system-init block-g1-sfm** command. Refer to [“Blocking discovery of G1 switch fabric modules”](#) on page 160.
- If the system is operating in Turbo mode, standard switch fabric modules (G1) and standard (G1) interface modules are automatically blocked.
- If there are any active G1 switch fabric modules, G2 interface modules are blocked.
- If there are any active G2 interface modules, G1 switch fabric modules are blocked.

Forcing HSF modules to operate in normal mode

NOTE

This procedure requires that you restart your router.

If necessary, you can configure HSF modules to operate in normal mode using the **system-init fabric-data-mode force normal** command.

```
Brocade(config)# system-init fabric-data-mode force-normal
```

Syntax: [no] **system-init fabric-data-mode force-normal**

If you remove the forced normal condition using the **no** version of this command, you must enter the **write-memory** command and restart the router.

Blocking discovery of G1 switch fabric modules

NOTE

This procedure requires that you restart your router.

In a router with both standard (G1) switch fabric modules and G2 HSF modules, you can block the discovery of the G1 switch fabric modules by entering the **system-init block-g1-sfm** command.

Syntax: **system-init block-g1-sfm**

After you enter this command, enter the **write -memory** command and restart the router.

Managing the cooling system

This section provides configuration, management, and monitoring information about router cooling systems.

Configuring the cooling system

Your router is pre-configured with default settings for all cooling system parameters. Although no initial configuration of the cooling system is necessary, you can change the settings of the following cooling system parameters:

- Low and high temperature thresholds for modules and fan speeds
- Interval at which the system polls the temperature sensors on the module for a reading

NOTE

Auto control of fan speed is not monitored when cards are in interactive mode. Set fan speed to high to prevent over-temp condition.

NOTE

Adjusting fan controls out of the default setting can negatively affect the efficient cooling of blades and may cause a blade to overheat and shutdown.

Changing temperature thresholds for modules and fan speeds

The cooling system includes fans that operate at four speeds: low, medium, medium-high, and high. In general, each fan speed, (except for low), has a low and high temperature threshold associated with it, as shown in [Figure 107](#). The low fan speed has a high temperature threshold only.

NOTE

Adjusting fan controls out of the default setting can negatively affect the efficient cooling of blades and may cause a blade to overheat and shutdown.

FIGURE 107 Fan speeds and temperature thresholds

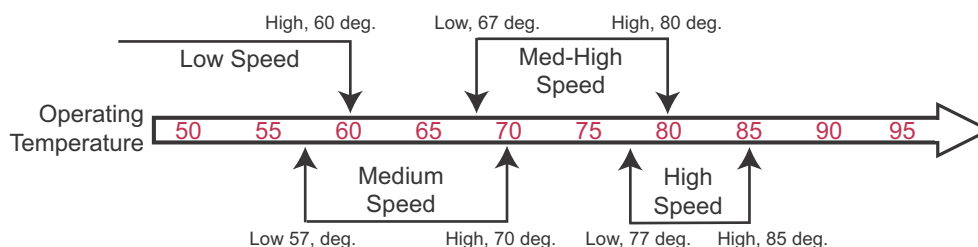

The low and high temperature thresholds allow the router to determine the speed at which the fans should operate. In general, the fans operate according to these guidelines:

- If the temperature of all modules falls between the low and high thresholds for a fan speed, the fan continues to operate at that speed.
- If the temperature of a management module, switch fabric module, or one interface module exceeds the high threshold specified for a fan speed, the fan changes to the next higher speed. If the temperature of any of the modules exceeds the high threshold for the high speed, the router shuts down the modules to prevent damage. The router also sends a warning message to the system log and an SNMP trap. For information about viewing the warning messages, refer to [“Displaying temperature warnings”](#) on page 169.
- The frequency with which the temperature is checked is determined by the setting of the **temp-poll-period** command. For information about **temp-poll-period** command, refer to [“Changing the temperature polling interval”](#) on page 167.
- If the temperature of a management module, switch fabric module, and interface modules falls below the low threshold for a fan speed, the fan changes to the next lower speed. If the temperature of all modules falls below the high threshold for the low speed, the fan operates at the low speed.

[Table 31](#) describes the default temperature thresholds for Brocade MLXe devices.

TABLE 31 Default temperature thresholds for modules and fan speeds for Brocade MLXe devices

Fan speed	Low temperature threshold	High temperature threshold
Management modules		
High	72° C	85° C
Medium-high	67° C	80° C
Medium	52° C	70° C
Low	-1°	60° C
Management modules CPU		
High	72° C	95° C
Medium-high	65° C	80° C
Medium	63° C	74° C
Low	-1°	70° C
Interface modules		
High	65° C	95° C
Medium-high	63° C	81° C
Medium	61° C	79° C
Low	-1°	74° C
Interface modules Packet Processor		
High	77° C	113° C
Medium-high	72° C	94° C
Medium	69° C	92° C
Low	-1°	90° C
Generation 2 Interface modules		
High	70° C	95° C

TABLE 31 Default temperature thresholds for modules and fan speeds for Brocade MLXe devices (Continued)

Fan speed	Low temperature threshold	High temperature threshold
Medium-high	62° C	80° C
Medium	58° C	75° C
Low	-1°	70° C
Generation 2 Interface modules Packet Processor		
High	74° C	113° C
Medium-high	70° C	87° C
Medium	66° C	85° C
Low	-1°	83° C
Switch fabric module		
High	47° C	75° C
Medium-high	37° C	50° C
Medium	27° C	40° C
Low	-1°	30° C
High-Speed Switch fabric module		
High	62° C	100° C
Medium-high	57° C	70° C
Medium	53° C	65° C
Low	-1°	60° C

For information about checking the current low and high temperature threshold settings for modules and fan speeds, refer to [“Displaying temperature thresholds for modules and fan speeds”](#) on page 164.

NOTE

Adjusting fan controls out of the default setting can negatively affect the efficient cooling of blades and may cause a blade to overheat and shutdown.

You can change the default low and high temperature thresholds for a particular module and fan speed. For example, to change the low and high thresholds of the medium fan speed for the management modules to 56° C and 72 °s C, respectively, enter the following command at the global CONFIG level of the CLI.

```
Brocade(config)# fan-threshold mp med 56 72
```

Syntax: `fan-threshold module [low high-threshold] [med low-threshold high-threshold] [med-high low-threshold high-threshold] [high low-threshold high-threshold]`

For the *module* parameter, you can specify the following:

- **lp** – Changes low and high temperature thresholds for Gen 1 interface modules
- **lp2** – Changes low and high temperature thresholds for Gen 2 interface modules
- **mp** – Changes low and high temperature thresholds for management modules
- **mp-cpu** – Changes low and high temperature thresholds for the management module CPU
- **switch-fabric** – Changes low and high temperature thresholds for non-high-speed switch fabric modules
- **switch-fabric-g2** – Changes low and high temperature thresholds for high speed switch fabric modules (hSFM)

For the *low-threshold* and *high-threshold* parameters, you can specify any temperature in Centigrade. However, when changing low and high temperature thresholds for module fan speeds, remember that the low temperature threshold of a *higher* fan speed must be lower than the *high* temperature threshold of the lower fan speed. Brocade has established this guideline to ensure fan speed stability.

For example, if you are changing the temperature thresholds for a management module high and medium-high fan speeds, the system will accept the following values because the low temperature threshold for the high speed (79° C) is lower than the high temperature threshold (82° C) for the medium-high speed.

Fan speed	Low temperature threshold	High temperature threshold
High	79° C	87° C
Medium-high	69° C	82° C

The device will **not** accept the following values because the low temperature threshold for the high speed (83° C) is higher than the high temperature threshold (82° C) for the medium-high speed.

Fan speed	Low temperature threshold	High temperature threshold
High	83° C	87° C
Medium-high	69° C	82° C

Displaying temperature thresholds for modules and fan speeds

To check the current settings of the low and high temperature thresholds for modules and fan speeds, you can enter the **show fan-threshold** command at any level of the CLI.

```
Brocade# show fan-threshold
=== Thermal Sensor Control Block (THERMAL_SENSOR_TEST_RULE_MP) ===
Fan Speed Low: -1 - 60
Fan Speed Med: 57 - 70
Fan Speed Med-Hi: 67 - 80
Fan Speed Hi: 77 - 85
state = 0 (FAN_STATE_LOW)
max_ts_shut_off_count = 1
shut_off_count = 0 0 0 0 0 0 0 0 0 0 0 0 0 0 0
=== Thermal Sensor Control Block (THERMAL_SENSOR_TEST_RULE_SNM) ===
Fan Speed Low: -1 - 30
Fan Speed Med: 27 - 40
Fan Speed Med-Hi: 37 - 50
Fan Speed Hi: 47 - 75
state = 2 (FAN_STATE_MED_HI)
max_ts_shut_off_count = 1
shut_off_count = 0 0 0 0 0 0 0 0 0 0 0 0 0 0 0
=== Thermal Sensor Control Block (THERMAL_SENSOR_TEST_RULE_LP) ===
```

```

Fan Speed Low: -1 - 50
Fan Speed Med: 46 - 55
Fan Speed Med-Hi: 51 - 60
Fan Speed Hi: 56 - 95
state = 0 (FAN_STATE_LOW)
max_ts_shut_off_count = 1
shut_off_count = 0 0 0 0 0 0 0 0 0 0 0 0 0 0 0 0
=== Thermal Sensor Control Block (THERMAL_SENSOR_TEST_RULE_LP_XPP) ===
Fan Speed Low: -1 - 50
Fan Speed Med: 45 - 65
Fan Speed Med-Hi: 60 - 75
Fan Speed Hi: 70 - 113
state = 1 (FAN_STATE_MED)
max_ts_shut_off_count = 1
shut_off_count = 0 0 0 0 0 0 0 0 0 0 0 0 0 0 0 0
=== Thermal Sensor Control Block (THERMAL_SENSOR_TEST_RULE_STANDBY_MP) ===
Fan Speed Low: -1 - 60
Fan Speed Med: 57 - 70
Fan Speed Med-Hi: 67 - 80
Fan Speed Hi: 77 - 85
state = 0 (FAN_STATE_LOW)
max_ts_shut_off_count = 1
shut_off_count = 0 0 0 0 0 0 0 0 0 0 0 0 0 0 0 0
=== Thermal Sensor Control Block (THERMAL_SENSOR_TEST_RULE_MP_CPU) ===
Fan Speed Low: -1 - 60
Fan Speed Med: 57 - 70
Fan Speed Med-Hi: 67 - 80
Fan Speed Hi: 77 - 95
state = 1 (FAN_STATE_MED)
max_ts_shut_off_count = 1
shut_off_count = 0 0 0 0 0 0 0 0 0 0 0 0 0 0 0 0
=== Thermal Sensor Control Block (THERMAL_SENSOR_TEST_RULE_STANDBY_MP_CPU) ===
Fan Speed Low: -1 - 60
Fan Speed Med: 57 - 70
Fan Speed Med-Hi: 67 - 80
Fan Speed Hi: 77 - 95
state = 0 (FAN_STATE_LOW)
max_ts_shut_off_count = 1
shut_off_count = 0 0 0 0 0 0 0 0 0 0 0 0 0 0 0 0

```

Syntax: show fan-threshold

The output displays the following information.

TABLE 32 Temperature threshold information for modules and fan speeds

This field...	Displays...
Thermal Sensor Control Block (THERMAL_SENSOR_TEST_RULE_ module)	The temperature threshold information for the various modules. The <i>module</i> parameter indicates the following: <ul style="list-style-type: none"> • MP – The active management module • STANDBY_MP – The standby management module • SNM – The switch fabric module • LP – An interface module
Fan Speed Low or Med or Med-Hi or Hi	The current setting of the low and high temperature thresholds for the low, medium, medium-high, and high fan speeds. <p>NOTE: As indicated in Table 33, the low fan speed for each module does not have a default low temperature threshold value, nor can you configure this value. The “-1” value that appears in the Fan Speed Low field for each module is a Brocade internal value only.</p>

TABLE 32 Temperature threshold information for modules and fan speeds (Continued)

This field...	Displays...
State = 0 (FAN_STATE_LOW)	For Brocade internal use only.
max_ts_shut_off_count	For Brocade internal use only.
shut_off_count = 0 0 0 0 0 0 0	For Brocade internal use only.

When syslog messages display a change in fan speed, you can identify which sensors triggered the change by checking **show chassis** and **show fan-threshold** command output and looking for sensors with temperatures near threshold boundaries. [Table 33](#) lists the associations between the **show chassis**, **show fan-threshold**, and **fan-threshold** commands.

NOTE

A "thermal block" refers to the group of high and low thresholds for all fan speed levels.

TABLE 33 Associations between show chassis, show fan threshold, and fan-threshold commands

show chassis command output (sensors)	show fan-threshold command output (thermal block)	fan-threshold command configuration
MP, SFM, and hSFM Modules		
Active Management 1st reading	THERMAL_SENSOR_TEST_RULE_MP	fan-threshold mp
Active Management 2nd reading	THERMAL_SENSOR_TEST_RULE_MP_CPU	fan-threshold mp-cpu
Standby Management 1st reading	THERMAL_SENSOR_TEST_RULE_STANDBY_MP	fan-threshold mp
Standby Management 2nd reading	THERMAL_SENSOR_TEST_RULE_STANDBY_MP_CPU	fan-threshold mp-cpu
SFM FE1 reading	THERMAL_SENSOR_TEST_RULE_SNM	fan-threshold switch-fabric
SFM FE2 reading	THERMAL_SENSOR_TEST_RULE_SNM	fan-threshold switch-fabric
SFM FE3 reading	THERMAL_SENSOR_TEST_RULE_SNM	fan-threshold switch-fabric
hSFM FE1 reading	THERMAL_SENSOR_TEST_RULE_SNM_G2	fan-threshold switch-fabric-g2
hSFM FE2 reading	THERMAL_SENSOR_TEST_RULE_SNM_G2	fan-threshold switch-fabric-g2
hSFM FE3 reading	THERMAL_SENSOR_TEST_RULE_SNM_G2	fan-threshold switch-fabric-g2
LP Modules (1 or 2 Traffic Managers)		
LP Sensor 1 reading (TM 0)	THERMAL_SENSOR_TEST_RULE_LP	fan-threshold lp
LP Sensor 2 reading (TM 0)	THERMAL_SENSOR_TEST_RULE_LP_XPP	N/A (Must not be changed)
LP Sensor 3 ^a reading (TM 1)	THERMAL_SENSOR_TEST_RULE_LP	fan-threshold lp
LP Sensor 4 ^b reading (TM 1)	THERMAL_SENSOR_TEST_RULE_LP_XPP	N/A (Must not be changed)
NI-MLX-10Gx8-M LP Modules		
LP2 Sensor 1 reading	THERMAL_SENSOR_TEST_RULE_LP_2	fan-threshold lp2
LP2 Sensor 2 reading	THERMAL_SENSOR_TEST_RULE_LP_XPP2	N/A (Must not be changed)
LP2 Sensor 3 reading	UNUSED	UNUSED
LP2 Sensor 4 reading	THERMAL_SENSOR_TEST_RULE_LP_2	fan-threshold lp2
LP2 Sensor 5 reading	THERMAL_SENSOR_TEST_RULE_LP_XPP2	N/A (Must not be changed)

TABLE 33 Associations between show chassis, show fan threshold, and fan-threshold commands (Continued)

show chassis command output (sensors)	show fan-threshold command output (thermal block)	fan-threshold command configuration
LP2 Sensor 6 reading	UNUSED	UNUSED
LP2 Sensor 7 reading	UNUSED	UNUSED
BR-MLX-100Gx2-X LP Modules		
LP2 Sensor 1 reading	THERMAL_SENSOR_TEST_RULE_LP_2	fan-threshold lp2
LP2 Sensor 2 reading	THERMAL_SENSOR_TEST_RULE_LP_XPP2	N/A (Must not be changed)
LP2 Sensor 3 reading	UNUSED	UNUSED
LP2 Sensor 4 reading	THERMAL_SENSOR_TEST_RULE_LP_2	fan-threshold lp2
LP2 Sensor 5 reading	THERMAL_SENSOR_TEST_RULE_LP_XPP2	N/A (Must not be changed)
LP2 Sensor 6 reading	UNUSED	UNUSED
LP2 Sensor 7 reading	UNUSED	UNUSED
LP2 Sensor 8 reading	UNUSED	UNUSED
LP2 Sensor 9 reading	UNUSED	UNUSED
LP2 Sensor 10 reading	UNUSED	UNUSED
LP2 Sensor 11 reading	UNUSED	UNUSED
LP2 Sensor 12 reading	UNUSED	UNUSED

- a. The four sensors may be displayed in the **show chassis** command output as Sensor1, Sensor2, Sensor4, and Sensor5. In that case, Sensor4 and Sensor 5 refer to the LP and LP XPP sensors on the second traffic manager, TM 1.
- b. The four sensors may be displayed in the **show chassis** command output as Sensor1, Sensor2, Sensor4, and Sensor5. In that case, Sensor4 and Sensor 5 refer to the LP and LP XPP sensors on the second traffic manager, TM 1.

Changing the temperature polling interval

By default, the router reads the temperature sensor on each module every 60 seconds. To change the polling interval, enter the **temp-poll-period** command at the global CONFIG level of the CLI.

```
Brocade(config)# temp-poll-period 120
```

Syntax: **temp-poll-period** *seconds*

For the *seconds* parameter, you can specify a value from 30 – 120.

NOTE

Adjusting temperature polling interval out of the default setting can negatively affect the efficient cooling of blades and may cause a blade to overheat and shutdown.

Manually setting the fan speed

Typically, the management module, in conjunction with default settings of low and high temperature thresholds, determines the speed of the two four-speed fans. (For information about changing the low and high temperature thresholds, refer to [“Changing temperature thresholds for modules and fan speeds”](#) on page 161.) You can manually set the fan speed using the **set-fan-speed** command in the Global CONFIG level of the CLI.

NOTE

Auto control of fan speed is not monitored when cards are in interactive mode. Set fan speed to high to prevent over-temp condition.

NOTE

Setting a value other than auto or high disables auto fan control and will negatively affect the efficient cooling of blades and may cause a blade to overheat and shutdown.

For example, to set the speed of fan 0 to medium-high, enter the following command.

```
Brocade# set-fan-speed med-high
```

Syntax: `set-fan-speed fan-speed`

For the *fan-speed* parameter, you can specify the following:

- **auto** – The system is adjusted by the monitoring system.
- **high** – The system sets the fan speed to high.
- **low** – The system sets the fan speed to low.
- **med** – The system sets the fan speed to medium.
- **med-high** – The system sets the fan speed to medium-high.

Monitoring the cooling system

You can monitor the following aspects of the router cooling system:

- The temperature of the fan control modules
- The status and speed of the fans
- The temperature warnings sent to the system log and that generate an SNMP trap

Displaying fan tray status and speed

To display the status and speed of the 4-speed fans in the router, enter the **show chassis** command at any level of the CLI.

```
Brocade# show chassis
...
--- FANS ---
Back fan tray 1: Status = OK, Speed = LOW (50%)
Back fan tray 2: Status = OK, Speed = LOW (50%)
Back fan tray 3: Status = OK, Speed = LOW (50%)
Back fan tray 4: Status = OK, Speed = LOW (50%)
```

Syntax: `show chassis`

For information about all output generated by the **show chassis** command, refer to [“Displaying device status and temperature readings”](#) on page 154.

TABLE 34 Fan status and speed fields

Field	Description
Status	The status can be one of the following: <ul style="list-style-type: none"> • OK – The fan is functioning properly and is keeping the temperature of each module within an acceptable temperature range. • Failed – The fan is not functioning properly or the fan control module cannot control the fan.
Speed	The speed can be one of the following: <ul style="list-style-type: none"> • LOW – The fan is functioning at 50 percent of capacity. • MEDIUM – The fan is functioning at 75 percent of capacity. • MEDIUM-HIGH – The fan is functioning at 90 percent of capacity. • HIGH – The fan is functioning at 100 percent of capacity.

Displaying temperature warnings

If the temperature of a module exceeds the high temperature threshold for any of the fan speeds, the system sends a warning message to the system log and an SNMP trap. (For more information about the low and high temperature thresholds, refer to [“Changing temperature thresholds for modules and fan speeds”](#) on page 161.) This section describes how to view the system log. If you have configured your router to use a Syslog server or SNMP trap receiver, refer to the documentation for the server or receiver.

To display the system log, enter the show log command at any CLI level.

```
Brocade# show log
```

Syntax: show log

Temperature log reduction

Depending on settings and temperature readings, fan speeds are changed dynamically within the following ranges: low, med, med-hi, and high. Fan speed changes are determined by temperature thresholds set for sensors on the management modules, interface modules and switch fabric modules. When a temperature threshold is passed upward on any module, the fan speed changes to the assigned fan speed. This occurs even if the temperature is within the threshold for the slower fan speed on other modules. In previous versions of the software, a log message is sent whenever a temperature threshold is crossed on any module whether the fan speed is actually increased or not. This can result in excessive log messages.

The default behavior is a for log message to be sent only when the fan speed is actually changed, which reduces the number of messages. A CLI option allows you to log all messages or have a single log message sent when any temperature threshold is crossed.

Details about how to set temperature thresholds and default threshold values are described in the [“Configuring the cooling system”](#) on page 161

Configuring temperature logging

The **temp log-threshold** command sets the temperature logging threshold to send a single message whenever any of the thresholds are crossed.

```
Brocade(config) temp-log-threshold low
```

Syntax: temp-log-threshold [verbose | high | low | med | med-high]

- The **verbose** option generates logs whenever a temperature threshold is crossed. This is the operational mode of previous versions of Multi-Service IronWare software and provides backward compatibility.
- The **high** option generates logs only when the high threshold is crossed.
- The **low** option generates logs whenever any threshold (low, medium, medium-high or high) is crossed.
- The **med** option generates logs only when the medium, medium-high, and high thresholds are crossed.
- The **med-high** option generates logs only when the medium-high and high thresholds are crossed. This is the default setting.

This output displays two instances of a module temperature exceeding the warning threshold.

Managing interface modules

Configuring interface module boot parameters

Ethernet interface modules contain independent copies of system software and boot after the management module boots. By default, the following boot-related events occur:

- The router synchronizes, or prompts you to synchronize, the software image on the interface modules with the software on the management module.
- Interface modules boot from a source specified by the management module (the default source is a primary image in the flash memory on the interface module.)

You can make these changes:

- Disable the synchronization of images between the management module and all interface modules. You can also initiate an immediate synchronization.
- Change the boot source of one or all interface modules.

Synchronizing the software image between management modules and interface modules

An interface module can have primary and secondary images that reside in the flash memory.

If you copy the primary or secondary image to all interface modules using the **copy** command with the **all** keyword, the management module makes a copy of the file and stores it in code flash under the names *Ip-primary-0* or *Ip-secondary-0*. The images are stored in this location only and are not run by the management module or the interface modules. If you copy the primary or secondary image to a specified device slot using the **copy** command with the *device-slot-number* parameter, the management module does not make a copy of the file.

If the management module has a copy of the primary or secondary image in code flash, by default, the router synchronizes, or prompts you to synchronize, images between the management module and the interface modules during the boot process. When the router synchronizes the images, the management module copies the images from flash memory to the flash memory on the interface module (the default boot source for the interface modules).

You can manage synchronization of the software images between management and interface modules in the following situations:

- You are prompted to synchronize the software images during the boot process.
- You want to initiate an immediate synchronization; for example, you want an immediate update of the software images on one or all interface modules.
- You want to disable synchronization; for example, you have upgraded the image of one interface module but want to continue running the older image on all other interface modules.

The following sections discuss how to manage software image synchronization in these situations.

Synchronizing the software image on interface modules during the boot process

By default, the router checks the software images in the flash memory on interface modules during the boot process to see if they are the same as the images in the flash memory on the management module. If an interface module does not have a software image, the system automatically downloads the image from the management module to the interface module.

If an interface module has an image that is different from that on the management module, the system prompts you to take one of the following steps:

- To update the primary and secondary images on the interface module with the images on the management module, enter the **lp cont-boot sync slot-number** command at the Privileged EXEC prompt.
- To retain the software images on the interface module, enter the **lp cont-boot no-sync slot-number** command at the Privileged EXEC prompt.

Syntax: **lp cont-boot sync slot-number**

Syntax: **lp cont-boot no-sync slot-number**

Specifying an immediate synchronization

To immediately synchronize software images between the management module and one or all interface modules, enter the following command at the Privileged EXEC level.

```
Brocade# lp sync all
```

Syntax: **lp sync [all | slot-number]**

- The **all** keyword indicates that the immediate synchronization applies to all interface modules in the router.
- The *slot-number* parameter specifies the slot number that contains the interface module to which the immediate synchronization applies. You can specify 1 – 4 for 4-slot devices, 1 – 8 for 8-slot devices, 1 – 16 for 16-slot devices, or 1 – 32 for 32-slot devices.

Specifying an immediate shutdown

The management module takes approximately 16-20 seconds to shutdown all interface modules in a device after a reload is issued. During this time, the interface module continues sending packets. Enter the **lp fast-powerdown** command to immediately shut down all interface modules in a device after a reload is issued.

```
Brocade(config)# lp fast-powerdown
```

Syntax: **[no] lp fast-powerdown**

If you do not enter this command, by default, the interface module continues to forward packets for an extended time after the router is reloaded.

NOTE

You do not need to change the state of the interface module, or synchronize this shutdown with the standby management module.

Changing the boot source

By default, the interface modules boot from the primary image located in flash memory. You can change the boot source of one or all interface modules to one of the following sources:

- Management module
 - auxiliary flash card in slot 1 or 2
 - Primary or secondary image in the management module flash memory
- Interface module
 - Secondary image in interface module flash memory
- TFTP server

You can also specify an interactive boot, which allows you to enter a separate command after the interface module comes up. The command specifies the source from which one or all interface modules should boot.

When changing the boot source for one or all interface modules, you can specify one of the following:

- An immediate boot for one interface module from a specified source
- An automatic boot for one or all interface modules from a specified source starting with the next software reload or system reset and each reload or reset after that

The CLI command for specifying an immediate boot for one interface module is the same as that for specifying an automatic boot for one or all modules. The only difference is the CLI level from which you execute the command. You must specify the command for an immediate boot in the Privileged EXEC level and the command for an automatic boot in the global CONFIG level.

The following sections explain how to specify an immediate boot and an automatic boot.

Specifying an immediate boot

You can specify an immediate boot for one interface module from a specified source by entering the **lp boot system** command in the Privileged EXEC level. The entered command will override the default or configured boot source one time only.

Specifying an immediate boot from the auxiliary flash slots on the management module

To specify an immediate boot for the interface module installed in slot 1 from the auxiliary flash slot on the management module, enter the **lp boot system** command at the Privileged EXEC level of the CLI.

```
Brocade# lp boot system slot1 primary 1  
Syntax: lp boot system slot1 | slot2 filename slot-number
```

- The **slot1** and **slot2** keywords indicate the auxiliary flash slot on the management module from which to boot the interface module.
- The *filename* parameter specifies the name of the image from which to boot the interface module.
- The *slot-number* parameter specifies the device slot number that contains the interface module that will undergo an immediate boot. You can specify 1 – 4 for 4-slot devices, 1 – 8 for 8-slot devices, 1 – 16 for 16-slot devices, or 1 – 32 for 32-slot devices.

Specifying an immediate boot from management module flash memory

To specify an immediate boot from the primary image on the management module for the interface module installed in slot 1, enter the following command at the Privileged EXEC level of the CLI.

```
Brocade# lp boot system mp primary 1
```

Syntax: `lp boot system mp primary | secondary slot-number`

- The **primary** and **secondary** keywords specify the primary or secondary software image in flash memory on the management module.
- The *slot-number* parameter specifies the device slot number that contains the interface module that will undergo an immediate boot. You can specify 1 – 4 for 4-slot devices, 1 – 8 for 8-slot devices, 1 – 16 for 16-slot devices, or 1 – 32 for 32-slot devices.

Specifying an immediate boot from flash memory on the interface module

To specify an immediate boot from the primary image in flash memory on the interface module installed in slot 1, enter the following command at the Privileged EXEC level of the CLI.

```
Brocade# lp boot system flash primary 1
```

Syntax: `lp boot system flash [primary | secondary] slot-number`

- The **primary** and **secondary** keywords specify the primary or secondary image in the interface module flash memory.
- The *slot-number* parameter specifies the slot number that contains the interface module that will undergo an immediate boot. You can specify 1 – 4 for 4-slot devices, 1 – 8 for 8-slot devices, 1 – 16 for 16-slot devices, or 1 – 32 for 32-slot devices.

Specifying an immediate boot from a TFTP server

To specify an immediate boot for the interface module installed in slot 1 from a TFTP server, enter the following command at the Privileged EXEC level of the CLI.

```
Brocade# lp boot system tftp 123.123.123.123 primary 1
```

Syntax: `lp boot system tftp ip-address filename slot-number`

- The *ip-address* parameter specifies the IP address of the TFTP server from which the interface module will be booted.
- The *filename* parameter specifies the name of the image from which to boot the interface module.
- The *slot-number* parameter specifies the slot number that contains the interface module that will undergo an immediate boot. You can specify 1 – 4 for 4-slot devices, 1 – 8 for 8-slot devices, 1 – 16 for 16-slot devices, or 1 – 32 for 32-slot devices.

Specifying an immediate interactive boot

To specify an immediate interactive boot for the interface module installed in slot 1, enter the following command at the Privileged EXEC level of the CLI.

```
Brocade# lp boot system interactive 1
```

Syntax: `lp boot system interactive slot-number`

- The *slot-number* parameter specifies the slot number that contains the interface module that will undergo an immediate boot. You can specify 1 – 4 for 4-slot devices, 1 – 8 for 8-slot devices, 1 – 16 for 16-slot devices, or 1 – 32 for 32-slot devices.

After you enter this command, the system enters monitor mode on the interface module. To boot from the primary image in flash memory on the interface module, enter the following command at the monitor prompt.

```
LP MONITOR> boot system flash primary
```

Syntax: `boot system flash primary`

Configuring an automatic boot

To configure an automatic boot for one or all interface modules from a specified source, enter the **lp boot system** command in the global CONFIG level. If you save this configuration by entering the **write memory** command, the system implements the automatic boot starting with the next software reload or system reset and each reload or reset after that.

Configuring an automatic boot from the auxiliary flash slot on the management module

To configure an automatic boot for all interface modules from auxiliary flash slot1 on the management module, enter the following command at the global CONFIG level of the CLI.

```
Brocade(config)# lp boot system slot1 primary all
```

Syntax: `lp boot system [slot1 | slot2] filename [all | slot-number]`

- The **slot1** and **slot2** keywords indicate the auxiliary flash slot on the management module from which to boot the interface modules.
- The *filename* parameter specifies the name of the image from which to boot the interface modules.
- The **all | slot-number** parameter specifies that the automatic boot applies to all interface modules in the device or to an interface module in the specified device slot number only. You can specify 1 – 4 for 4-slot devices, 1 – 8 for 8-slot devices, 1 – 16 for 16-slot devices, or 1 – 32 for 32-slot devices.

Configuring an automatic boot from flash memory on the management module

To configure an automatic boot from the primary image in flash memory on the management module for all interface modules, enter the following command at the global CONFIG level of the CLI.

```
Brocade(config)# lp boot system mp primary all
```

Syntax: `lp boot system mp [primary | secondary] [all | slot-number]`

- The **primary** and **secondary** keywords specify the primary or secondary image in flash memory on the management module.
- The **all | slot-number** parameter specifies that the automatic boot applies to all interface modules in the device, or to an interface module in the specified device slot number only. You can specify 1 – 4 for 4-slot devices, 1 – 8 for 8-slot devices, 1 – 16 for 16-slot devices, or 1 – 32 for 32-slot devices.

Configuring an automatic boot from flash memory on the interface module

To configure an automatic boot from the primary image in flash memory on the interface module for all interface modules, enter the following command at the global CONFIG level of the CLI.

```
Brocade(config)# lp boot system flash primary all
```

Syntax: `lp boot system flash [primary | secondary] [all | slot-number]`

- The **primary** and **secondary** keywords specify the primary or secondary image in the interface module flash memory.
- The **all | slot-number** parameter specifies that the automatic boot applies to all interface modules in the device or to an interface module in the specified slot number only. You can specify 1 – 4 for 4-slot devices, 1 – 8 for 8-slot devices, 1 – 16 for 16-slot devices, or 1 – 32 for 32-slot devices.

Configuring an automatic boot from a TFTP server

To configure an automatic boot for all interface modules from a TFTP server, enter the following command at the global CONFIG level of the CLI.

```
Brocade(config)# lp boot system tftp 123.123.123.123 primary all
```

Syntax: `lp boot system tftp ip-address filename [all | slot-number]`

- The *ip-address* parameter specifies the IP address of the TFTP server from which the interface modules will be booted.
- The *filename* parameter specifies the name of the image from which to boot the interface modules.
- The **all | slot-number** parameter specifies that the automatic boot applies to all interface modules in the router or to an interface module in the specified router slot number. You can specify 1 – 4 for 4-slot routers, 1 – 8 for 8-slot routers, 1 – 16 for 16-slot routers, or 1 – 32 for 32-slot routers.

Configuring an automatic interactive boot

To configure an automatic interactive boot for all interface modules, enter the following command at the global CONFIG level of the CLI.

```
Brocade(config)# lp boot system interactive all
```

Syntax: `lp boot system interactive [all | slot-number]`

The **all | slot-number** parameter specifies that the automatic boot applies to all interface modules in the router, or to an interface module in the specified slot number. You can specify 1 – 4 for 4-slot routers, 1 – 8 for 8-slot routers, 1 – 16 for 16-slot routers, or 1 – 32 for 32-slot routers.

After you enter this command, the system enters monitor mode on the interface module. To boot from the primary image in flash memory on the interface module, enter the following command at the monitor prompt.

```
LP MONITOR> boot system flash primary
```

Syntax: `boot system flash primary`

Changing priority of slots for interface modules

You can prioritize the slots in which the interface modules are installed. The priority range is 1 (low) – 8 (high). You can set one, some, or all slots to the same priority or each slot to a different priority. If you assign the same priority to all slots, the lowest-number slot has the highest priority, while the highest-numbered slot has the lowest priority.

By default, the priority of all slots is 1, which is the lowest priority. If the supply of power to the router falls below a minimum threshold, the slots will likely lose power because of their low priority. In this scenario for an 8-slot router, slot 8 will lose power first, then slot 7, slot 6, and so on until slot 1 loses power.

To set the priority of slot 1 to the highest priority (8), enter the following command.

```
Brocade(config)# lp-slot-priority 1 8
```

Syntax: `lp-slot-priority slot-number priority`

- The *slot-number* parameter indicates that the slot number for which you are changing the priority. You can specify 1 – 4 for 4-slot routers, 1 – 8 for 8-slot routers, 1 – 16 for 16-slot routers, or 1 – 32 for 32-slot routers.
- The *priority* parameter indicates the priority of the slot if the router loses power. You can specify a value of 1 – 8, where 1 is the lowest priority and 8 is the highest priority. You can set one, some, or all slots to the same priority or each slot to a different priority.

Disabling and re-enabling power to interface modules

You can disable and re-enable power to a specified interface module, or to all interface modules. For example, to disable power to the interface module in slot 1, enter the following command at the Privileged EXEC level of the CLI.

```
Brocade# power-off lp 1
```

To disable power on all interface modules, enter the following command:

```
Brocade# power-off lp all
```

In this output example, there is one interface module in slot 2, which is powered off.

```
Brocade# power-off lp all
Slot 2 is powered off.
rw_power_off_lp: write 00030000 to RW_MBRIDGE_CARD_POWER_OFF_REG
```

Syntax: `power-off lp slot-number all`

- The *slot-number* parameter indicates the slot number for which you are disabling the power. You can specify 1 – 4 for 4-slot routers, 1 – 8 for 8-slot routers, 1 – 16 for 16-slot routers, or 1 – 32 for 32-slot routers.
- The **all** parameter allows you to power off all interface modules.

To re-enable power to the interface module in slot 1, enter the following command at the Privileged EXEC level of the CLI.

```
Brocade# power-on lp 1
```

To re-enable power on all interface modules, enter the following command.

```
Brocade# power-on lp all
```

In this output example, there is one interface module in slot 3 and slot 3 is powered on.

```
Brocade# power-on lp all
Slot 3 is powering on.
rw_power_on_lp: write 00070004 to RW_MBRIDGE_CARD_POWER_OFF_REG
```

Syntax: `power-on lp [slot-number] all`

- The *slot-number* parameter indicates the slot number for which you are re-enabling the power. You can specify 1 – 4 for 4-slot routers, 1 – 8 for 8-slot routers, 1 – 16 for 16-slot routers, or 1 – 32 for 32-slot routers.
- The **all** parameter allows you to power on all interface modules.

Monitoring Link Status

Software and hardware error conditions can bring down fabric links. When all links connecting a traffic manager to a backplane are down, the traffic manager will drop incoming traffic. If the port is still up, the traffic manager will continue to drop data. NetIron R05.3.00 and later solve this problem continuously running a software task on the LP that monitors link status. If it detects that if the fabric links between the traffic manager and the backplane are down, the software shuts down the ports connected to that traffic manager, resulting in no continuous traffic drop. If all of the following criteria are met, the software brings the ports back up:

- all the links come back up
- at least 30 percent of the total links are in the “up” state
- the port is enabled and there are no additional blocking conditions

Enabling monitoring link status

This feature is included by default in NetIron R05.3.00 and later; no configuration is required to enable it.

Disabling monitoring link status

To disable the link status monitoring feature, enter the following command:

```
no system-monitoring tm port-control
```

Displaying fabric link status

To display the fabric link status, enter the following command:

```
MLX#show sfm-links 1
SFM#/FE# | FE link# | LP#/TM# | TM link# | link state
-----+-----+-----+-----+-----
  1 / 1 |    13    |  2 / 1 |    13    |        UP
  1 / 1 |    17    |  2 / 2 |    01    |       DOWN
  1 / 1 |    14    |  2 / 1 |    01    |        UP
```

Syntax: `show sfm-links sfm-number | all [errors]`

The *sfm-number* variable specifies an SFM that you want to display link information for.

The **all** option displays link information for all SFMs in the chassis.

The **errors** option only displays information for SFM links that are in the DOWN state.

The output of this command can also be filtered using an output modifier. To use an output modifier, type a vertical bar (|) followed by a space and one of the following parameters:

- **begin** - begin output with the first matching line
- **exclude** - exclude matching lines from the output

- **include** - include only matching lines in the output
- A warning statement is sent if the number of operational links falls below the minimum threshold. This warning is displayed to warn users that the line rate traffic will not be maintained. [Table 35](#) describes the information the **show sfm-links** command displays.

TABLE 35 CLI display of SFM link information

This field...	Displays...
SFM#	The switch fabric module number.
FE#	The FE number.
FE link#	The number of the interconnect between the SFM and the FE.
LP#	The slot number where the Interface module (LP) is installed.
TM#	The number of the traffic manager used in the link.
TM link#	The link number on the traffic manager.
link state	The link state is either: UP - In an operating condition DOWN - In a non-operational condition

Syslog messages

The following syslog messages are related to link monitoring:

- System: Interface Ethernet 3/1, state down -fabric connectivity down
- System: Interface Ethernet 3/1, state up -fabric connectivity up

Using alarms to collect and monitor device status

Beginning in Brocade NetIron R05.3.00, the software keeps two logs; one of hardware status currently available to the system, and another of hardware status history. The current alarm log keeps only entries for current information; when a hardware status is no longer valid, the entry is cleared. The alarm history log keeps a record of hardware statuses even after the status has changed. The alarm history log enables you to quickly determine trouble areas in a system. For example, by accessing the history, you can quickly determine if a problem is occurring too frequently and might require action.

Each hardware status entry is called an *alarm* and is classified by severity assigned by the software. The software categorizes alarms in the following levels:

- **Critical** - A condition that will cause damage to the system. A condition that causes a traffic outage on multiple ports.
- **Major** - A condition that causes traffic outage on single ports or might cause damage to the system.
- **Minor** - A condition that should be investigated but will not damage the system.

By default, all hardware status alarm levels of *major* severity and higher are logged, though you can configure the status alarm levels sent to both alarm logs (current and history). You can use the **show alarm** command to view the current status on a device, or a logged history of hardware alarms. To change the levels of alarms sent to the alarm logs, refer to [“Configuring Alarm History Buffer Size”](#) on page 179.

The alarms are specific to hardware status, whereas the syslog records information for software events. Alarms can also be configured on very specific terms such as a failed temperature sensor on a single interface module.

To take advantage of this feature, you should first set the alarm history buffer size. This is optional, but you have the option to limit how many entries are stored in the alarm history so you can free up space for other resources. Refer to “[Configuring Alarm History Buffer Size](#)” on page 179 for more information.

Next, you should configure the severity of alarms for each device you want logged. For detailed information, refer to “[Configuring alarm logging](#)” on page 179. Once you have configured your alarm logging, you can display alarms in the current alarm log and alarm history log using the show alarm command, as described in [Table 36](#) on page 181.

Configuring Alarm History Buffer Size

The history buffer size is configurable. The default buffer size is 400 entries, but it can be configured to list between 100 and 3000 entries using the **alarm history** command.

For example, to configure the alarm history log size to 100 entries, enter the following command:

```
Brocade# alarm history 100
```

Syntax: [no] alarm history *n*

where *n* is the number of log entries you want to store in the alarm history log, between 100 and 3000.

To reset the alarm history back to the default buffer size, use the **alarm history** command with the *no* operand. For example, to set the buffer size back to the default entry size from 100, enter the following command:

```
Brocade# no alarm history 100
```

Configuring alarm logging

You can configure the system to log only specific level alarms *for specific devices using the alarm* command. The configuration setting applies to both logs, the current and history alarm logs. The level you set is the minimum level of alarms that will be logged. For example, if you set the configuration to log a minimum of minor level events, all minor, major and critical events will be logged. If you set the configuration to log a minimum of major level events, all major and critical events will be logged. If you set the configuration to log a minimum of critical level events, only critical level events will be logged.

For example, to configure the system to log a minimum of major level alarms on an interface module in slot 1, optic in slot 9, enter the following command:

```
Brocade# alarm lp 1 optic 9 major
```

Alarms of major and critical severity will be logged for the optic in slot 9 on interface module in slot 1.

To reset the alarm history severity logging back to the default severity level, use the **alarm** command with the *no* operand. For example, to reset the alarms for the example above back to default, enter the following command:

```
Brocade# no alarm lp 1 optic 9 major
```

NOTE

You cannot configure alarm severity on a system wide basis; you must specify a specific device, such as a fan, power supply or optic device.

Once an alarm is set to log a minimum alarm level, the show commands cannot display alarm levels of lower severity levels as the information is not logged.

Displaying alarms

This section describes how to display alarms. You can display alarms at a very basic or specific level. The alarm logs display alarms they have been configured to log. The alarm history log is displayed in chronological order starting with the most recent entry.

NOTE

By default, all hardware status alarm levels of *major* severity and higher are logged. If you have configured different levels to be logged, only those levels of alarms can be displayed using the **show alarm** command.

For example, to display all alarms on the system of major alarm level only, enter the following command:

```
Brocade# show alarm severity major
Jan 3 15:01:44 | Major | Chassis | Power-Supply 2 - Not Present
Jan 3 15:01:44 | Major | Chassis | Power-Supply 3 - Not Present
Jan 3 15:03:54 | Major | LP 1 | Optic 1 - Alarm
Jan 3 15:02:21 | Major | LP 1 | Optic 2 - Not Present
Jan 3 15:02:21 | Major | LP 1 | Optic 5 - Not Present
Jan 3 15:02:21 | Major | LP 1 | Optic 7 - Not Present
Jan 3 15:02:21 | Major | LP 1 | Optic 8 - Not Present
Jan 3 15:02:21 | Major | LP 1 | Optic 10 - Not Present
Jan 3 15:02:21 | Major | LP 1 | Optic 11 - Not Present
Jan 3 15:02:21 | Major | LP 1 | Optic 12 - Not Present
Jan 3 15:02:21 | Major | LP 1 | Optic 13 - Not Present
Jan 3 15:02:21 | Major | LP 1 | Optic 14 - Not Present
Jan 3 15:02:22 | Major | LP 1 | Optic 16 - Not Present
Jan 3 15:02:22 | Major | LP 1 | Optic 17 - Not Present
Jan 3 15:02:22 | Major | LP 1 | Optic 18 - Not Present
```

To display all alarms on the system of all alarm levels (as per your configured alarm severity logging), enter the following command:

```
Brocade# show alarm all
Jan 3 15:01:44 | Major | Chassis | Power-Supply 2 - Not Present
Jan 3 15:01:44 | Major | Chassis | Power-Supply 3 - Not Present
Jan 3 15:03:54 | Major | LP 1 | Optic 1 - Alarm
Jan 3 15:02:21 | Major | LP 1 | Optic 2 - Not Present
Jan 3 15:02:21 | Major | LP 1 | Optic 5 - Not Present
Jan 3 15:02:21 | Major | LP 1 | Optic 7 - Not Present
Jan 3 15:02:21 | Major | LP 1 | Optic 8 - Not Present
Jan 3 15:02:21 | Major | LP 1 | Optic 10 - Not Present
Jan 3 15:02:21 | Major | LP 1 | Optic 11 - Not Present
Jan 3 15:02:21 | Major | LP 1 | Optic 12 - Not Present
Jan 3 15:02:21 | Major | LP 1 | Optic 13 - Not Present
Jan 3 15:02:21 | Major | LP 1 | Optic 14 - Not Present
Jan 3 15:02:22 | Major | LP 1 | Optic 16 - Not Present
Jan 3 15:02:22 | Major | LP 1 | Optic 17 - Not Present
Jan 3 15:02:22 | Major | LP 1 | Optic 18 - Not Present
```

Table 36 describes how to use the **show alarm** command to display alarm information.

TABLE 36 Displaying alarm log information

Description	Syntax
To display the default alarm levels.	show alarm default
To display all current alarms of a specific severity: critical, major, or minor. Alarms displayed depend on what you have configured the alarm logs to record.	show alarm severity [<i>critical</i> <i>major</i> <i>minor</i>]
Use to display all alarms in the alarm logs. Use the history operand to display the alarm history log.	show alarm [history] all
To display all alarms in the alarm log for all devices in the chassis. Alarms displayed depend on what you have configured the alarm logs to record.	show alarm [history] chassis all
To display all alarms in the alarm log related to all subsystems within the chassis or events for a particular subsystem (where subsystem is power supply or fan) (where x is the device number)	show alarm [history] chassis subsystem <i>all</i> <i>x</i>
To display all alarms in the alarm log for all management modules and subsystems for the management modules.	show alarm [history] mp all
To display all alarms in the alarm log related to a specific management module (where n, module number is 1-3 for MLX/XMR and 1 for CER/CES) and all alarms for it's subsystems.	show alarm [history] mp n all
To display all alarms in the alarm log related to temperature information for a management module (where n, module number is 1-3 for MLX/XMR and 1 for CER/CES) and a specific fan (where x, is the temperature device number).	show alarm [history] mp n temperature [<i>all</i> <i>x</i>]
To display all alarms in the alarm log for all interface modules and subsystems for the management module.	show alarm [history] lp all
To display all alarms in the alarm log related to a specific interface module (where n, module number is 1-3 for MLX/XMR and 1 for CER/CES) and all alarms for it's subsystems.	show alarm [history] lp n all
To display all alarms in the alarm log related to subsystem information for an interface module (where n, module number is 1-3 for MLX/XMR and 1 for CER/CES) and either all events on a specific subsystem, or events for a particular subsystem (where subsystem is <i>temperature</i> or <i>optic</i>) (where x, is a the device number).	show alarm [history] lp n subsystem [<i>all</i> <i>x</i>]

TABLE 36 Displaying alarm log information (Continued)

Description	Syntax
To display all alarms in the alarm log for all SFM and subsystems for the SFM.	show alarm [history] sfm all
To display all alarms in the alarm log related to a specific SFM (where n, is SFM slot 1-8 for MLX/XMR) and all alarms for it's subsystems.	show alarm [history] sfm n all
To display all alarms in the alarm log related to SFM information for a specific SFM (where n, is SFM slot 1-8 for MLX/XMR) and either all events on a specific subsystem, or events for a particular subsystem (where subsystem is <i>temperature</i> or <i>fabric-element</i>) (where x is 1-4 for a fabric element device number).	show alarm [history] sfm n subsystem [all x]

Management and interface modules

When a management module or interface module is removed from the chassis, a major level alarm is generated in the alarm history log. If the management module, interface module, or SFM is powered off, a critical level alarm is generated in the alarm history log.

When a module is removed or powered off, alarms for all subsystems of the module are cleared from the current alarm log. If a module is removed from the chassis, all alarms are cleared from the current alarm log, and memory associated to its subsystems is freed. When a module is added to the configuration, memory is reallocated.

Temperature

If temperature on the management module or interface module increases to the highest threshold, a major alarm is set. If temperature decreases below the highest threshold, the alarm is cleared from the current alarm log, and an additional alarm is sent to the alarm history log stating that the condition has been removed. If the temperature increases into shutdown range, a critical level alarm is reported and logged in the alarm logs.

Optics

Alarms and warnings are monitored only for optic devices that support optical monitoring. If optical monitoring is disabled, then no alarms are generated.

If an optic is removed or not present, a major alarm is reported and logged and any existing alarms are cleared from the current alarm log.

NOTE

Alarms are not generated for optic device insertion.

Switch fabric element

If a switch fabric element cannot be accessed, a major alarm is reported and logged.

Chassis fans, power supplies, and optics

If there is an indication that a single fan has failed, a major alarm is reported and logged on the tray. If an incompatible fan tray is detected, a major alarm is reported and logged on the tray. When a fan tray is removed, any existing alarms are cleared and a major alarm is reported and logged on the tray.

If a power supply is installed but powered down, a minor alarm is reported and logged. If a power supply is installed incorrectly, a major alarm is reported and logged. If a power supply is not present, a major alarm is reported and logged.

Clearing the alarm history log

Use the **clear alarm** command to remove some or all of the current alarms. Once the alarm is cleared, it is removed from the current alarm database and is no longer available even though the condition might still exist. The alarm is kept in the history log.

If you clear all alarms, a single entry is added to the history that indicates all alarms have been cleared.

To clear all alarms from the alarm logs, enter the following command:

```
Brocade# clear alarm all
```

For example, if you want to clear all alarms from the alarm logs on a specific optic in slot 9 of the interface module in slot 1, enter the following command:

```
Brocade# clear alarm lp 1 optic 9
```

Disabling SNMP trap generation and logging

With the introduction of the alarm feature, you may want to disable some SNMP trap generation and logging to save space.

To disable SNMP fan change-trap generation, enter the following command:

```
Brocade(config)# no snmp-server enable traps fan-speed-change
```

To disable Syslog fan-speed-change logging, enter the following command:

```
Brocade(config)# no logging enable fan-speed-change
```

For additional information on SNMP traps and logging, refer to the *Unified MIB Reference*.

Displaying MR2 management module memory usage

In NetIron R05.3.00 and later, you can use all 4G of physical memory on the MR2 management module. To display MR2 memory usage, enter the following command:

```
Brocade# show mem
```

ID	Memory Used	Available	Success	Hold	Fail	Error	
0	21401600	14397440	1508	633	0	0	OS
1	51474432	216961024	22	22	0	0	Shared
2	107184128	2747834368	25969	10813	0	0	Global
3	0	267386880	0	0	0	0	User Private
4	0	267386880	0	0	0	0	Priv4

5 Enabling and disabling management module CPU usage calculations

```
5 0          267386880    0      0      0      0      Priv5
6 0          267386880    0      0      0      0      Priv6
7 0          267386880    0      0      0      0      Priv7
8 0          267386880    0      0      0      0      Priv8
9 0          267386880    0      0      0      0      Priv9
10 0         267386880    0      0      0      0      Priv10
11 0         267386880    0      0      0      0      Priv11
12 0         267386880    0      0      0      0      Priv12
- 19722240   47386624    10     10     0      0      DMA
Total Installed: 4294967295, Total Free: 3988713472
```

Syntax: `show memory`

Enabling and disabling management module CPU usage calculations

You can enable the router to perform usage averaging calculations on tasks handled by CPU on the management module. You can then display usage averages for all tasks performed by the CPU on the management module for an interval of up to one hour. You can display these statistics using the `show cpu` command.

NOTE

Typically, these statistics are used for debugging purposes.

By default, the performance of the calculations is disabled. When disabled, you can use the `show cpu` command without optional parameters to display usage averages for all tasks performed by CPU on the management module.

NOTE

The `cpu-usage` command must be configured in order to poll the MP CPU utilization.

To enable the usage averaging calculations, enter the following command at the global CONFIG level of the CLI.

```
Brocade(config)# cpu-usage on
```

Syntax: `cpu-usage on`

To disable the usage averaging calculations, enter the following command at the global CONFIG level of the CLI.

```
Brocade(config)# cpu-usage off
```

Syntax: `cpu-usage off`

NOTE

When you are finished gathering statistics for debugging purposes, it is recommended that you disable the usage averaging calculations, which are CPU-intensive and can affect the performance of the management module.

Displaying CPU usage

Use the `show cpu` command to display usage averages for all tasks performed by the management module as shown in this example.

```
Brocade# show cpu
... Usage average for all tasks in the last 1 seconds ...
=====
Name                us/sec                %
```

idle	755423	100
monitor	13	0
wd	46	0
flash	0	0
dbg	6	0
boot	92	0
main	0	0
itc	0	0
tmr	588	0
ip_rx	211	0
scp	36	0
console	54	0
vlan	0	0
mac_mgr	38	0
mrp	0	0
vsrp	0	0
snms	71	0
rtm	640	0
rtm6	40	0
ip_tx	2478	0
rip	0	0
mpls	119	0
nht	0	0
mpls_glue	13	0
bgp	0	0
bgp_io	0	0
ospf	737	0
ospf_r_calc	0	0
isis	38	0
isis_spf	0	0
mcast	18	0
msdp	134	0
vrrp	0	0
ripng	0	0
ospf6	66	0
ospf6_rt	0	0
mcast6	7	0
bfd	0	0
l4	98	0
stp	0	0
gvrp_mgr	0	0
snmp	0	0
rmon	13	0
web	86	0
lacp	0	0
dot1x	0	0
dot1ag	7	0
hw_access	1049	0
ospf_msg_task	0	0
telnet_0	0	0
telnet_1	44	0

Syntax: show cpu

Displaying management module CPU usage

You can display the tasks handled by the management module and the amount of the management module CPU used by each task by entering the **show tasks** command at any level of the CLI.

```
Brocade# show tasks
Task Name   Pri   State   PC       Stack     Size  CPU Usage(%)  task id  task vid
-----
idle 0      run    00001904 040560a0 256   66            0        0
monitor 20     susp   0000c658 0404bd80 8192  0             0        0
int 16     susp   0000c658 04051f90 16384 0             0        0
timer 15     susp   0000c658 04055f90 16384 0             0        0
dbg 30     susp   0000c658 0404df10 8192  0             0        0
flash 17     susp   0000c658 0409cf98 8192  0             0        0
wd 31     susp   0000c658 0409af80 8192  0             0        0
boot 17     susp   0000c658 041dbe30 65536 0             0        0
main 3      susp   0000c658 2060cf38 65536 0             0        1
itc 6      susp   0000c658 20610af0 16384 0             0        1
tmr 5      susp   0000c658 206a7638 16384 0             0        1
ip_rx 5     susp   0000c658 206aef48 16384 0             0        1
scp 5      susp   0000c658 206b3638 16384 0             0        1
console 5    susp   0000c658 206bf628 32768 0             0        1
vlan 5     susp   0000c658 206c6628 16384 0             0        1
mac_mgr 5   susp   0000c658 206d5638 16384 0             0        1
mrp_mgr 5   susp   0000c658 206db638 16384 0             0        1
vsrp 5     susp   0000c658 206e1630 16384 0             0        1
snms 5     susp   0000c658 206e5638 16384 0             0        1
rtm 5      susp   0000c658 20756638 16384 0             0        1
ip_tx 5     run    0000c658 20763638 16384 0             0        1
mcast 5    susp   0000c658 20767638 16384 0             0        1
l4 5      susp   0000c658 2076b630 16384 0             0        1
stp 5      susp   0000c658 20970628 16384 0             0        1
gvrp_mgr 5  susp   0000c658 20979638 16384 0             0        1
snmp 5     susp   0000c658 20982638 32768 0             0        1
web 5      susp   0000c658 2098d638 32768 0             0        1
lACP 5     susp   0000c658 20991638 16384 0             0        1
hw_access 5 susp   0000c658 20996638 16384 0             0        1
telnet_0 5     run    0000c658 209db638 32768 0             0        1
```

Syntax: show tasks

Examine the CPU Usage (%) field to determine the percentage of management module CPU used by each task.

NOTE

The total CPU usage may not add up to 100 percent. The total may not include resources used by the management processes.

A problem could exist if the CPU usage is distributed unevenly to one task, other than the idle task, for a prolonged period. If this situation occurs, contact Brocade Technical Support for assistance.

Removing MAC address entries

You can remove the following learned MAC address entries from the system MAC address table:

- All MAC address entries
- All MAC address entries for a specified interface module
- All MAC address entries for a specified Ethernet port
- All MAC address entries for a specified VLAN
- A specified MAC address entry in all VLANs

For example, to remove entries for the MAC address 000d.cb80.00d in all VLANs, enter the following command at the Privileged EXEC level of the CLI.

```
Brocade# clear mac-address 000d.cb80.00d0
```

Syntax: `clear mac-address mac-address [ethernet slot-num/port-num] | [module slot-num] | vlan number`

- If you enter the **clear mac-address** command without any parameters, the software removes all MAC entries.
- Use the *mac-address* parameter to remove a specified MAC address from all VLANs. Specify the MAC address in the following format: HHHH.HHHH.HHHH.
- Use the **ethernet slot-num/port-num** parameter to remove all MAC addresses for a specified Ethernet port. For the *slot* parameter, enter the number of the device slot in which the Ethernet interface module is installed. For the *port* parameter, enter the Ethernet port for which to remove all MAC addresses.
- Use the **module slot-num** parameter to remove all MAC addresses for an interface module in a specified device slot.
- Use the **vlan number** parameter to remove all MAC addresses for a specified VLAN.

5 Removing MAC address entries

Maintenance and Field Replacement

This chapter describes how to perform any required maintenance on your device. It also describes how to install the following field-replaceable hardware:

- Management modules
- Compact flash cards in management modules
- Interface modules
- Switch fabric modules
- Fiber optic transceivers
- Fans
- Power supplies
- Fan deflectors
- Air filters

Hardware maintenance schedule



DANGER

The procedures in this manual are for qualified service personnel.

Brocade routers require minimal maintenance for hardware components. It is recommended that you perform the following regular maintenance tasks:

- Clean the fiber-optic connectors on a fiber-optic transceiver port and the connected fiber cable each time you disconnect the cable.
- Replace the air filters quarterly.

You can also replace the following hardware components, as needed:

- All modules (management, interface, and switch fabric).
- Fiber-optic transceivers.
- AC or DC power supplies.
- Fan assemblies.

NOTE

The management, interface, and switch fabric modules are dedicated, which means that you must install them in Brocade routers only. If you install these modules in another Brocade device or you install a module intended for another Brocade device in a Brocade router, the device and modules will not function properly.

Replacing a management module

For instructions on how to install or replace modules, refer to the module installation section in the installation chapter for your router model.

Installing the Compact Flash Card in an MR2 management module

MR2 management modules allow users to insert an additional 2 Gbps compact flash card. To install the card, you need a flat head or Phillips screw driver. Refer to [Figure 108](#) to see where the slot card should be placed.

NOTE

MR and MR2 management modules should not be used together in the same chassis.

Please read the Hardware Installation Notes that came with your hardware before installing the MR2 management module.

The internal compact flash card cannot be accessed for removal or replacement.

To obtain a replacement or a new compact flash card, contact Brocade technical support.

To install a compact flash card in an MR2 management module:

1. Remove the two screws holding the compact flash card cover in place using a flat head or Phillips screw driver.

Put the screws and cover plate aside; you will need to reattach the cover using the screws after installing the card.

2. Slide the compact flash card into the slot.
3. Reattach the cover plate using the two screws and screwdriver.

FIGURE 108 Inserting a compact flash card in the MR2 management module

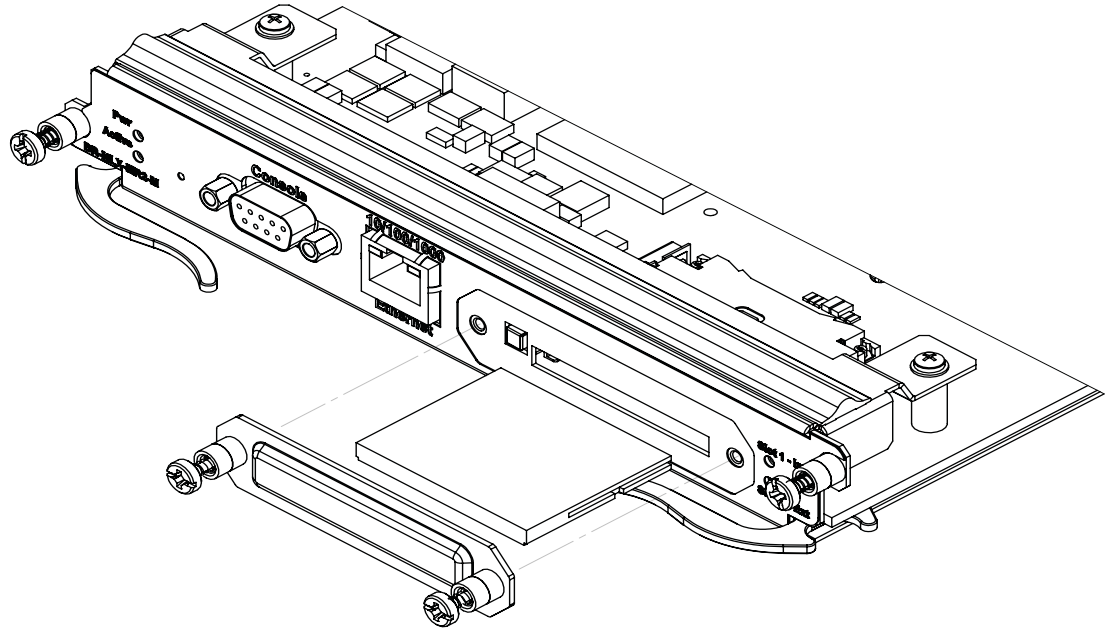

Replacing an interface module

You can remove or replace interface modules while the router is powered on and running. For more information on module slot locations, refer to [Chapter 1, "Product Overview"](#).

NOTE

It is not recommended that you hot-swap an interface module that is running a software image older or newer than the image on the management module. Although the management module will attempt to sync the application image on the interface module, it may not be able to sync older FPGA images. In this case the interface module may attempt to continuously reload. Always upgrade or downgrade the FPGA images on replacement interface modules to match the software version on the management module before you install the interface modules in your device.

For information about how to install a new or replacement module, refer to the installation chapter for your router model.



CAUTION

If you are hot-swapping a component, allow a minimum of two seconds after a component has been removed before inserting a replacement component in the same slot.

Removing and replacing an interface module

To remove or replace an interface module, see the module instructions in the installation chapter that is appropriate for your router model.

6 Replacing a switch fabric module

For 16-slot routers, if you insert a module into a slot where the fan speed for a previous module was manually configured, you will need to change the fan speed back to auto. For example, if the fan speed was manually configured to “slow”, and you are installing a module that requires more cooling power, the “slow” setting will cause the module to overheat. To configure the fan speed to auto, enter the following command:

```
Brocade# set-fan-speed auto
```

Syntax: set-fan-speed auto

Due to the high cable capacity of 32-slot routers, cable bundles can be very dense. The design of the cable management system allows you to access interface modules in the top row of the upper card cage without having to disconnect cables from the bottom row of the same card cage. Simply move the cable bundles from the lower card cage to the side, as shown in [Figure 109](#).

FIGURE 109 Accessing the interface modules on a fully-loaded 32-slot chassis

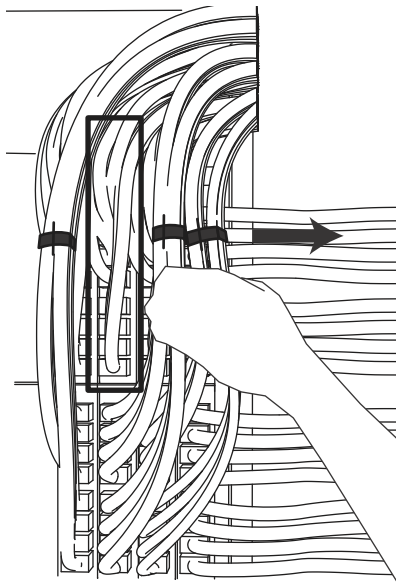

Replacing a switch fabric module

You can replace a switch fabric module while the router is powered on and running. For more information on switch fabric slot locations, refer to [“Switch fabric modules”](#) on page 30. For installation instructions for switch fabric modules, see the installation chapter that is appropriate for your router model.



CAUTION

If you are hot-swapping a component, please allow a minimum of two seconds after the old component has been removed before inserting a replacement component in the same slot.

For a graceful shutdown of the links, it is recommended that you disable the switch fabric module before removing it from the device. It is also recommended that you remove or replace switch fabric modules one at a time. If you need to remove all of the switch fabric modules at the same time, you must shut down the router and remove the power source.

Replacing a fiber-optic transceiver

You can replace a fiber-optic transceiver in a 10 Gigabit Ethernet port while the device is powered on and running.



DANGER

All fiber optics interfaces use Class 1 lasers.



DANGER

Laser Radiation. Do Not View Directly with Optical Instruments. Class 1M Laser Products

Before removing a fiber-optic transceiver, have the following items available:

- The protective covering that you removed from the fiber-optic transceiver port when you initially installed the module
- An ESD wrist strap with a plug for connection to the ESD connector on the router chassis.



DANGER

For safety reasons, the ESD wrist strap should contain a 1 megohm series resistor.

To replace a fiber-optic transceiver in a 10 Gbps Ethernet port, perform the following steps:

1. Put on the ESD wrist strap and ground yourself by inserting the plug into the ESD connector located on the front of the router.
2. Disconnect the two fiber cable connectors from the port connectors.
3. Replace the protective cover on the port connectors.
4. Pull down the latch on the front of the transceiver.
5. Pull the transceiver out of the port and place it in an anti-static bag for storage.
6. Remove the new transceiver from the protective packaging.
7. Insert the fiber-optic transceiver into the port until it clicks into place. Fiber-optic transceivers are keyed to prevent incorrect insertion.

Cabling a fiber-optic transceiver

To cable a fiber-optic transceiver, perform the following steps:

1. Before cabling a fiber-optic transceiver, it is strongly recommended that you clean the cable connectors and the port connectors. For more information, refer to [“Replacing a management module”](#) on page 190.
2. Gently insert the two cable connectors (a tab on each connector should face upward) into the port connectors until the tabs lock into place.

Replacing a power supply

You can replace a power supply while the device is powered on and running. For the location of the power supplies (AC or DC) refer to [Chapter 1, “Product Overview”](#).



CAUTION

If you are hot-swapping a module, power supply, or fan tray, allow a minimum of two seconds after a module (or power supply or fan tray) has been removed before inserting a module in the same slot.

Determining which power supply failed

To determine which power supply has failed, enter the **show chassis** command at any CLI command prompt.

```
Brocade# show chassis
```

This command displays status information for the fans and power supplies, and temperature readings for various components in the device. The power supplies are numbered in the display. Refer to [“Displaying device status and temperature readings”](#) on page 154 for more information.

If a power supply has failed, the display indicates “Installed (Failed)” and identifies the slot in which the failed power supply is installed.

Setting the threshold for power supply monitoring

The **power-supply monitoring threshold** command monitors the power supply state, and indicates when a power supply will shut down due to failure.

To set a threshold value for power supply monitoring, enter the following command.

```
Brocade(config)#power-supply monitoring threshold 3  
A Power Supply will be Shutdown if it fails 3 times within an Hour
```

The power supply will flap three times within an hour, after which the power supply will automatically shut down.

Syntax: [no] **power-supply monitoring** [threshold *decimal*]

The *decimal* variable specifies the number of flaps within an hour after which a power supply will automatically shutdown. The threshold range is from 0 through 32. The default value is 5. A value of 0 disables the power supply auto-shutdown on flapping.

NOTE

A threshold value of 0 will not automatically shutdown a power supply due to failures.

For Syslog messages, please refer to *Appendix A, Using Syslog in the Brocade MLX Series and Brocade NetIron Family Configuration Guide*.

Clearing power supply failure timestamps

Use the **power-supply monitoring clear** command to clear all collected failure timestamps for a given power supply, or for all available power supplies.

To clear all collected failure timestamps for a power supply, enter the following command.

```
Brocade(config)# power-supply monitoring clear 1
This will clear all collected failure timestamps for the Power Supply # 1
Are you sure? (enter 'y' or 'n'): y
```

To clear all collected failure timestamps for all available power supplies, enter the following command.

```
Brocade(config)# power-supply monitoring clear all
This will clear all collected failure timestamps for all available Power Supplies
Are you sure? (enter 'y' or 'n'): y
```

You are asked to verify this command by entering “yes” or “no.”

Syntax: **power-supply monitoring clear** *decimal* | **all**]

By default, no power-supply monitoring is configured.

The *decimal* variable specifies a power supply number, The **all** keyword clears all available power supplies.

Displaying power supply monitoring timestamps

To display timestamps for failures on any power supply, enter the following command.

```
Brocade #show power-supply-monitoring
      PS-1      PS-2      PS-3      PS-4
```

```
1 ) 0          0          0          0
2 ) 0          0          0          0
3 ) 0          0          0          0
4 ) 0          0          0          0
5 ) 0          0          0          0
6 ) 0          0          0          0
7 ) 0          0          0          0
8 ) 0          0          0          0
9 ) 0          0          0          0
10) 0          0          0          0
11) 0          0          0          0
12) 0          0          0          0
13) 0          0          0          0
14) 0          0          0          0
15) 0          0          0          0
16) 0          0          0          0
17) 0          0          0          0
18) 0          0          0          0
19) 0          0          0          0
20) 0          0          0          0
```

6 Replacing a power supply

```
21) 0      0      0      0
22) 0      0      0      0
23) 0      0      0      0
24) 0      0      0      0
25) 0      0      0      0
26) 0      0      0      0
27) 0      0      0      0
28) 0      0      0      0
29) 0      0      0      0
30) 0      0      0      0
31) 0      0      0      0
32) 0      0      0      0
```

Monitoring Threshold: 32 flaps/hour

In the example above, the configured power supply monitoring threshold is 32 cycles per hour.

You can also use the `show running-config` command to display the power supply monitoring threshold configuration, as displayed in the following example.

```
Brocade#show running-config
```

```
Current configuration:
!
ver V5.4.0T163
module 1 br-mlx-2-port-100g-x
module 3 ni-mlx-48-port-1g-mrj21
!
!
!
no logging enable ntp
logging console
telnet login-retries 5
telnet server
power-supply monitoring threshold 32
username script password 8 $1$hR/..5B1$adiszoS76gLD9zIyFF1ER1
```

In the example above, the configured power supply monitoring threshold is 32 cycles per hour.

Use the following command to show the uptime of modules:

```
Brocade#show version | include time
Active Management uptime is 9 minutes 30 seconds
Standby Management uptime is 8 minutes 45 seconds
LP Slot 3 uptime is 8 minutes 48 seconds
LP Slot 4 uptime is 8 minutes 48 seconds
LP Slot 5 uptime is 8 minutes 50 seconds
LP Slot 6 uptime is 8 minutes 50 seconds
LP Slot 8 uptime is 8 minutes 48 seconds
Brocade#
```

```
Brocade# show version | include xmr
Compiled on Jul 9 2012 at 09:52:52 labeled as xmr05400b396
Compiled on Jul 9 2012 at 09:52:52 labeled as xmr05400b396
Brocade#
```

The **show power-supply-monitoring** command displays the last 32 recorded failure timestamps for a power supply. The displayed failure timestamp is the number of seconds since the last system reboot. The current configured power supply monitoring threshold value is also displayed at the end of the output.

Syntax: show power-supply-monitoring

Enabling a power supply shutdown

NOTE

The **power-on power supply** and **power-off power-supply** commands are not available on some power supplies. These commands can be useful for Brocade Technical Support when troubleshooting a router. It is recommended you use the commands only when troubleshooting a router with Brocade Technical Support.

The **power-off power-supply** command allows you to shut down a power supply manually.

To shut down a power supply, enter the following command.

```
Brocade# power-off power-supply 3
This will Shutdown The Power Supply # 3
Are you sure? (enter 'y' or 'n'): y
ERROR: Power Supply # 3 is the Last Available in the system and will not be
shutdown.
```

To force the shutdown, please use keyword "forced"

Syntax: power-off power-supply [**forced**] *decimal*

The **power-supply** keyword allows you to shut down a power supply.

The *decimal* variable specifies a power supply index number.

The forced option forces the last power supply available in the system to shut down. The CLI will not shut down the last power supply unless the **forced** option is used.

Powering on the power supply through the CLI

NOTE

The **power-on power supply** and **power-off power-supply** commands are not available on some power supplies. These commands can be useful for Brocade Technical Support when troubleshooting a router. It is recommended you use the commands only when troubleshooting a router with Brocade Technical Support.

Use the **power-on power-supply** command to turn on a power supply that has been shut down.

A power supply will shut down due to flapping, or if a shutdown is enabled manually using the **power-off power-supply** command. Refer to [“Enabling a power supply shutdown”](#) on page 197.

To turn on a power supply that has shut down, enter the following command.

```
Brocade# power-on power-supply 1
AC Power Supply 1 is OK
```

The output example displays the status for power supply 1 as OK.

NOTE

If a power supply has shut down, power to the interface module may be lost, as there may not be enough power remaining in the system to keep the module powered.

6 Replacing a power supply

Syntax: power-on [power-supply *decimal*]

The *decimal* variable specifies a power supply index number.

Replacing a power supply

To replace a power supply, have the following items available:

- A new power supply (AC or DC), which you can order from Brocade
- A small flat-blade or Phillips screwdriver (Brocade MLX-4 and Brocade 32-slot modules)



DANGER

The power supplies are hot swappable, which means they can be removed and replaced while the device is powered on and running. However, Brocade recommends that you disconnect the power supply from its power source before removing and replacing the supply. The device can be running while a power supply is being removed and replaced, but the power supply itself should not be connected to a power source. Otherwise, you could be injured or the power supply or other parts of the device could be damaged.



DANGER

The front panel of a power supply includes a handle that locks the power supply in the device. This handle is a locking mechanism only and should not be used to lift and carry the power supply. You may sustain physical injury or harm if you attempt to lift and carry a power supply using the locking handle.

1. Disconnect the power supply from the power source.
2. Disconnect the power cables from the power supply.
3. Remove the power supply from the device:
 - For a 4-slot device: Use the screwdriver to loosen the two screws on both sides of the power supply faceplate. Then pull the ejectors forward until the power supply disconnects from the backplane.
 - For an 8-slot or 16-slot device: Pull up on the plunger on the faceplate and pull the handle toward you until the power supply is released.
 - For a 32-slot device: Make sure the captured screw underneath the latch handle on the power supply faceplate is loose. Pull down on the latch handle and curl your fingers over the handle. Pull the handle straight out toward you to unlock the power supply (see [Figure 110](#)).

Pull the power supply out of the device.

FIGURE 110 Removing and replacing a power supply in a 32-slot device.

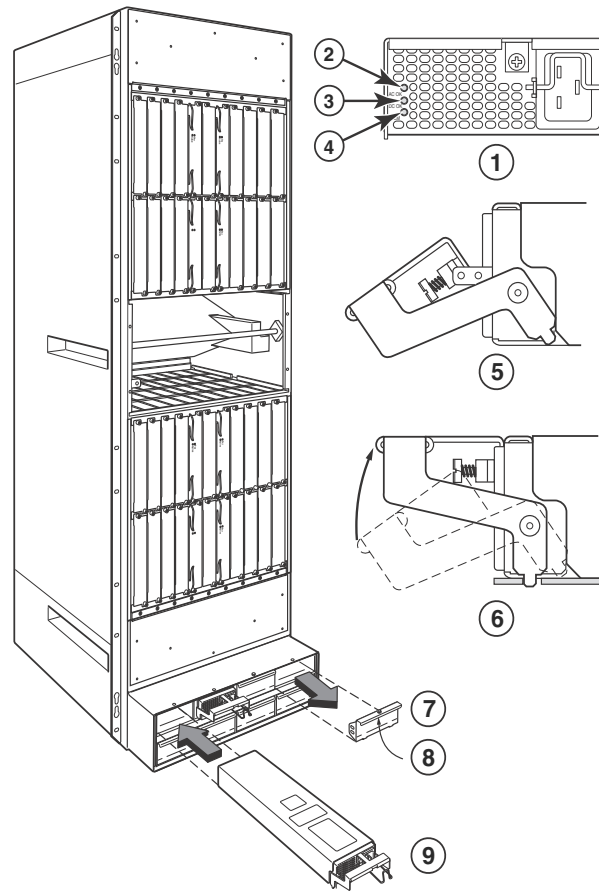

- | | | | |
|---|-------------------------|---|--------------------------------|
| 1 | Power supply indicators | 6 | Latch handle locked |
| 2 | AC OK | 7 | Power supply blank cover |
| 3 | DC OK | 8 | Pull down on plunger to remove |
| 4 | ALM | 9 | Power supply |
| 5 | Latch handle open | | |

4. Insert the new power supply into the empty power supply slot, using the guides provided on either side of the slot.

**CAUTION**

Carefully follow the mechanical guides on each side of the power supply slot and make sure the power supply is properly inserted in the guides. Never insert the power supply upside down.

5. After you insert the power supply, push gently on the power supply faceplate until the power supply is fully seated.
6. Pull up on the handle on the power supply faceplate to lock the power supply in place.

7. For a 4-slot device only, use the screwdriver to secure the two screws on either side of the power supply faceplate.
8. For a 2400W DC power supply only, crimp the #4 AWG power supply wire in the power lugs.
9. For a 3000W DC power supply only, crimp the #2 AWG power supply wire in the power lugs.
10. Connect the AC power cord or DC power lugs to the power supply faceplate.
11. Connect the power to the AC or DC source.

LEDs on the power supply faceplate show the status of the power supply with the following colors:

- For a DC supply, the DC IN and DC OUT LEDs should be green, indicating the power supply is providing power to the device components.
- For an AC supply, the AC OK and DC OK LEDs should be green, indicating the power supply is providing power to the device components (refer to [Figure 110](#)).
- If the ALM LED is lit (amber), the power supply has failed.

For information about troubleshooting this problem, refer to [Table 33](#) on page 229.

Replacing fan assemblies

You can replace a fan or a fan control module while the router is powered on and running. The fans and fan control modules are located on the rear panel of the router.

NOTE

Fan trays are hot swappable. However, a hot-swap procedure should be completed within five minutes so the device will continue to function correctly without any fans. It is recommended that you disconnect the power supply from AC or DC power before installing or removing the fan tray.

While fan assemblies are being replaced, and there is an increase or decrease in fan-speed due to that, syslogs or console messages are not generated.

Replacing fan assemblies in all 32-slot routers

This section describes how to replace fan assemblies in MLXe 32-slot routers.



CAUTION

Removing the rear fan modules on a 32-slot router provides access to bus bars and backplane. Avoid contact with these parts. There are hazardous energy levels at these locations.

A 32-slot router has ten fan assemblies located at the rear of the router. They are numbered as indicated in [Figure 111](#).

You can remove and replace a fan assembly while the router is powered on and running.

**CAUTION**

To avoid overheating of the router, remove one fan assembly at a time, and replace it promptly. Wait for the LED on the fan assembly being replaced to turn green before replacing another fan assembly. Do not remove all fans from the device at once.

Before replacing a fan assembly, have the following items available:

- A new fan assembly, which you can order from Brocade
- A small flat-blade screwdriver
- An ESD wrist strap with a plug for connection to the ESD connector on the front of the device.

**DANGER**

For safety reasons, the ESD wrist strap should contain a 1 megohm series resistor.

Use the following steps to replace a fan assembly.

1. Put on the ESD wrist strap and ground yourself by inserting the plug into the ESD connector on the router.
2. Using the screwdriver, remove the screws that secure the fan assembly faceplate to the rear of the router.
3. Remove the fan assembly by grasping the handle on the faceplate and pulling the assembly toward you as shown in [Figure 112](#). Pulling the fan assembly unseats the fan connector from the device.

**DANGER**

The 32-slot router fan assembly is heavy and will be off-balance as you remove it. Use both hands on the handle.

**DANGER**

Be careful not to insert your fingers into the fan while removing it from the device. The fan may still be spinning at a high speed.

6 Replacing fan assemblies

FIGURE 111 32-slot router fan assemblies

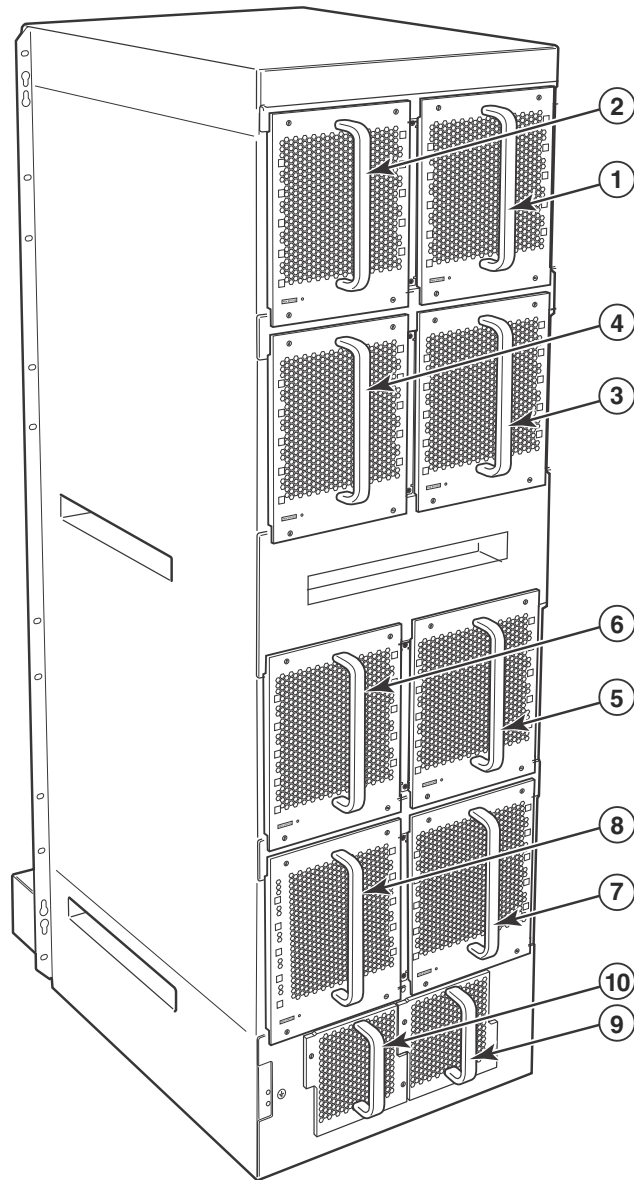

- | | |
|----------------|------------------|
| 1 Fan module 1 | 6 Fan module 6 |
| 2 Fan module 2 | 7 Fan module 7 |
| 3 Fan module 3 | 8 Fan module 8 |
| 4 Fan module 4 | 9 Fan module 9 |
| 5 Fan module 5 | 10 Fan module 10 |

4. Insert the new fan assembly into the fan slot and push the assembly in until the faceplate is flush with the router. Pushing the fan assembly in seats the fan connector in the router connector.
5. Secure the fan assembly to the router by replacing and tightening the four screws (on the upper eight fan assemblies) and the two screws (on the lower two fan assemblies).

6. Check the fan status LED in the lower left corner of the faceplate. It will light red momentarily when power is applied, then change to green when the fan comes up to speed.
7. Access the CLI, and enter the **show chassis** command to verify that the fan is operating normally.

Replacing fan assemblies in 16-slot routers

Brocade MLXe 16-slot routers have two fan assemblies accessible from the rear of the router. You can remove and replace a fan assembly while the router is powered on and running.



CAUTION

To avoid overheating of the 16-slot router, remove one fan assembly at a time, and replace it promptly. Do not remove all fans from the device at once.

To replace a fan assembly, you need the following:

- A new fan assembly, which you can order from Brocade.
- A small flat-blade screwdriver.
- An ESD wrist strap with a plug for connection to the ESD connector on the router.



DANGER

For safety reasons, the ESD wrist strap should contain a 1 megohm series resistor.

Replacing the rear fan assemblies in 16-slot routers

The instructions for replacing the rear fan assemblies in the 16-slot router apply to both standard) and high-speed fan assemblies.

Perform these steps to replace a rear fan assembly.

1. Put on the ESD wrist strap and ground yourself by inserting the plug into the ESD connector on the router.
2. Loosen the four captive screws that secure the fan assembly to the router.
3. Remove the fan by inserting your fingers underneath the fan assembly and pulling the assembly toward you as shown in [Figure 112](#). Pulling the fan assembly unseats the fan connector from the router connector.



DANGER

Be careful not to insert your fingers into the fan while removing it. The fan may still be spinning at a high speed.

FIGURE 112 Replacing a fan assembly in a MLXe 16-slot router

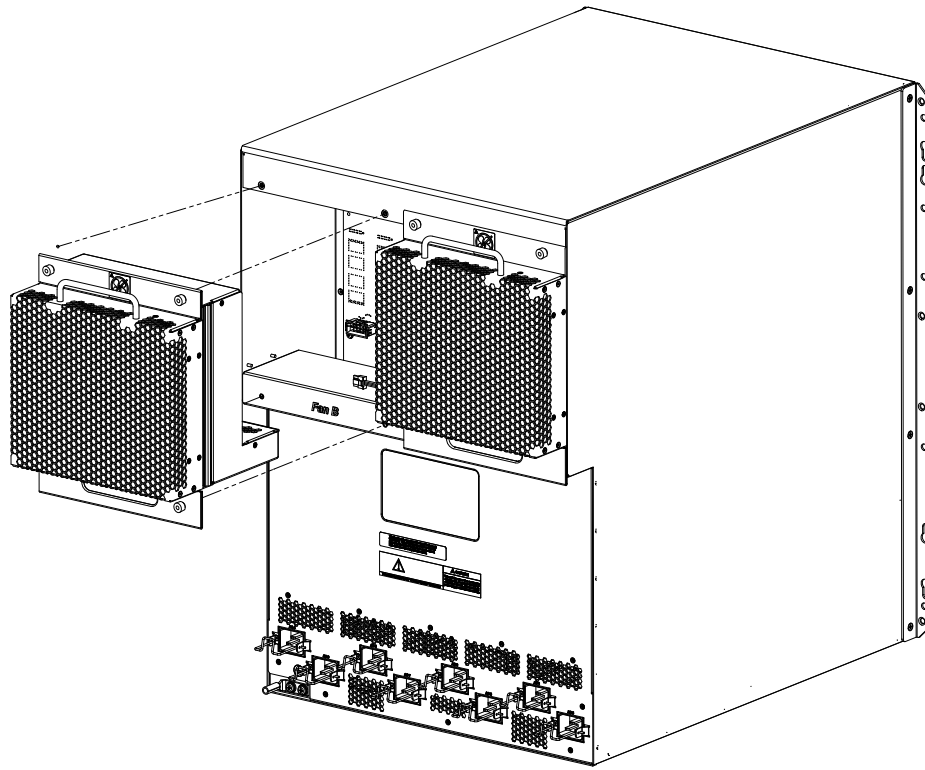

4. Insert the new fan assembly into the slot and push the assembly in until the faceplate is flush with the device. Pushing the assembly in seats the fan connector with the device connector.
5. Secure the fan assembly to the device by tightening the four captive screws.
6. Access the CLI, and enter the **show chassis** command to verify that both fans are operating normally.

Replacing the fan tray assembly in 4-slot and 8-slot routers

The fan tray assemblies for Brocade MLXe 4-slot and 8-slot routers are accessible from the back of the device.

You can remove and replace a fan tray assembly while the router is powered on and running.

To replace a fan tray assembly, have these items available:

- A new fan tray assembly, which you can order from Brocade.
- An ESD wrist strap with a plug for connection to the ESD connector on the router.



DANGER

For safety reasons, the ESD wrist strap should contain a 1 megohm series resistor.

NOTE

If you did not remove the extra shipment screws from the router during installation, you will not be able to remove the fan tray assembly. You will need to remove the router from the rack to remove the shipping screws, (refer to the installation chapter appropriate for your router model) before you can remove the fan tray assembly.

Follow these steps to replace fan tray assemblies in 4-slot routers.

1. Put on the ESD wrist strap and ground yourself by inserting the plug into the ESD connector on the router.
2. To remove the fan tray assembly from the router, push down on the latch release with your thumb, grasp the handle, and pull it toward you as shown in [Figure 113](#) and [Figure 114](#). Pulling the assembly unseats the fan tray assembly connector from a router connector.

**DANGER**

Be careful not to insert your fingers into the fan while removing it. The fan may still be spinning at a high speed.

FIGURE 113 Replacing the fan assembly in a Brocade MLXe 4-slot router

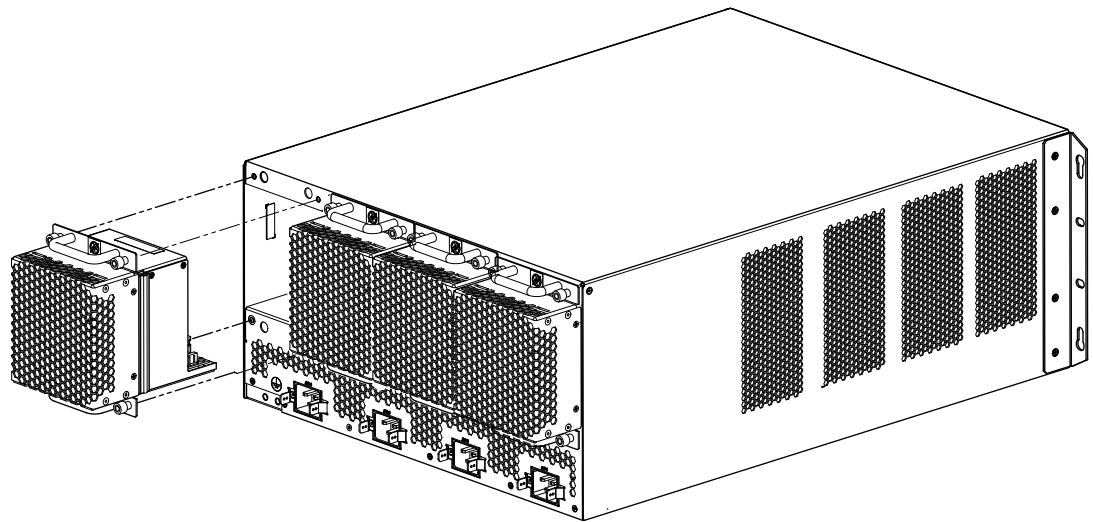
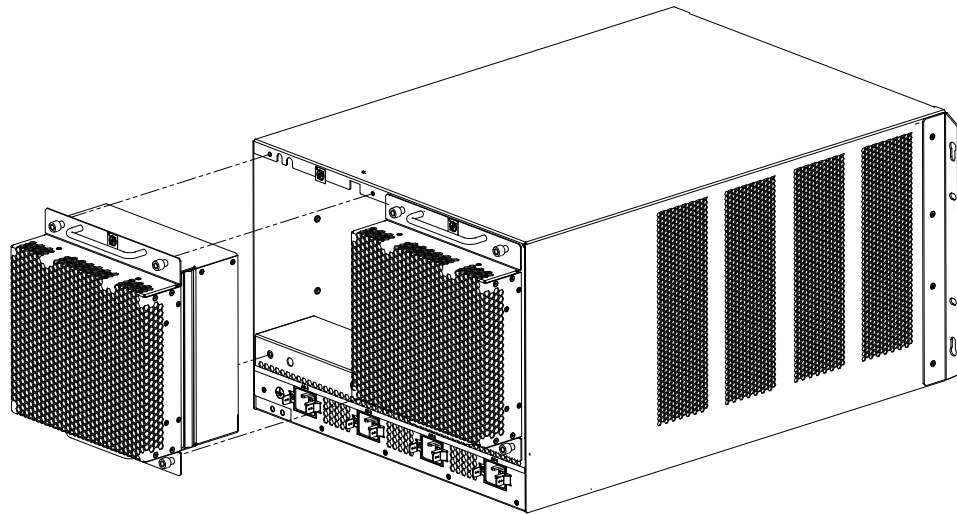

FIGURE 114 Replacing the fan assembly in a Brocade MLXe 8-slot router



3. Insert the new fan assembly into the fan slot and push the enclosure in until the faceplate is flush with the router. Pushing the enclosure in seats the fan connector with the router connector.
4. Tighten the four captive screws to secure the fan to the router.
5. Access the CLI, and enter the **show chassis** command to verify that the fans are operating normally.

Replacing the air filters

It is strongly recommended that routers be installed in environments that have minimal dust and airborne contaminants. If routers are installed in environments where dust or other airborne contaminants may be present, air filters should be inspected and replaced as needed. Maintaining clean air filters ensures optimal airflow through the devices.

You can replace the air filters while a router is powered on and running. Before performing this task, have these items available:

- A 7/64 inch hex head screwdriver
- Replacement air filters, which you can order from Brocade

Replacing the air filters in 32-slot routers

The two air filters in 32-slot routers are located between the upper and lower card cages. To replace an air filter, perform these steps.

NOTE

Air filters for 32-slot routers are marked with a directional arrow to indicate proper alignment for the direction of airflow in the device. The upper filter should be inserted with the arrow pointing up, and the lower filter should be inserted with the arrow pointing down.

1. From the front of the router, remove the air inlet cover by unscrewing the four captive screws with a 7/64 inch hex head screwdriver, as shown in [Figure 115](#).

FIGURE 115 32-slot router air inlet panel.

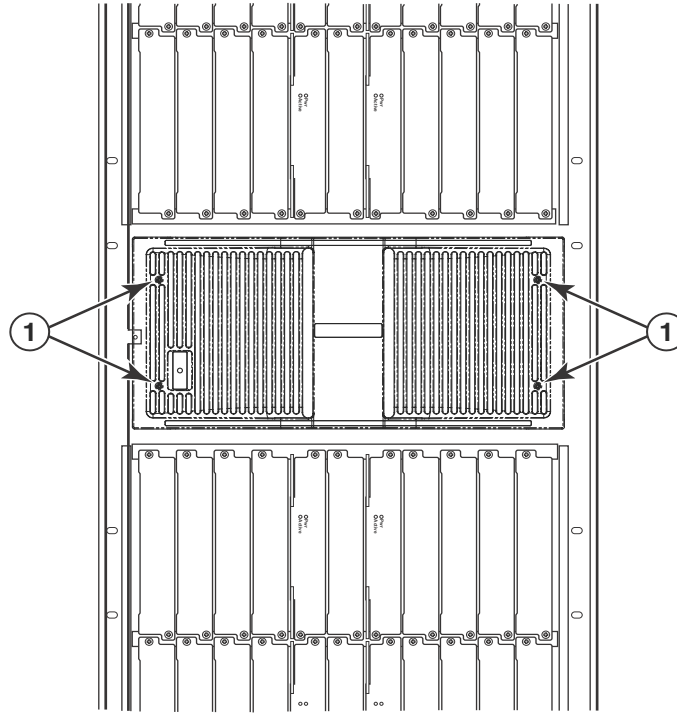

- 1 Captive screws
2. Remove the old air filter by pulling it straight out from the router, as shown in [Figure 116](#).
3. Insert a new filter, being careful that it aligns within the narrow channel.
4. Repeat steps 2 and 3 to replace the second filter.
5. Replace the air inlet cover and tighten the four captive screws to secure the air filter to the router.

FIGURE 116 Air filter removal and replacement for 32-slot routers

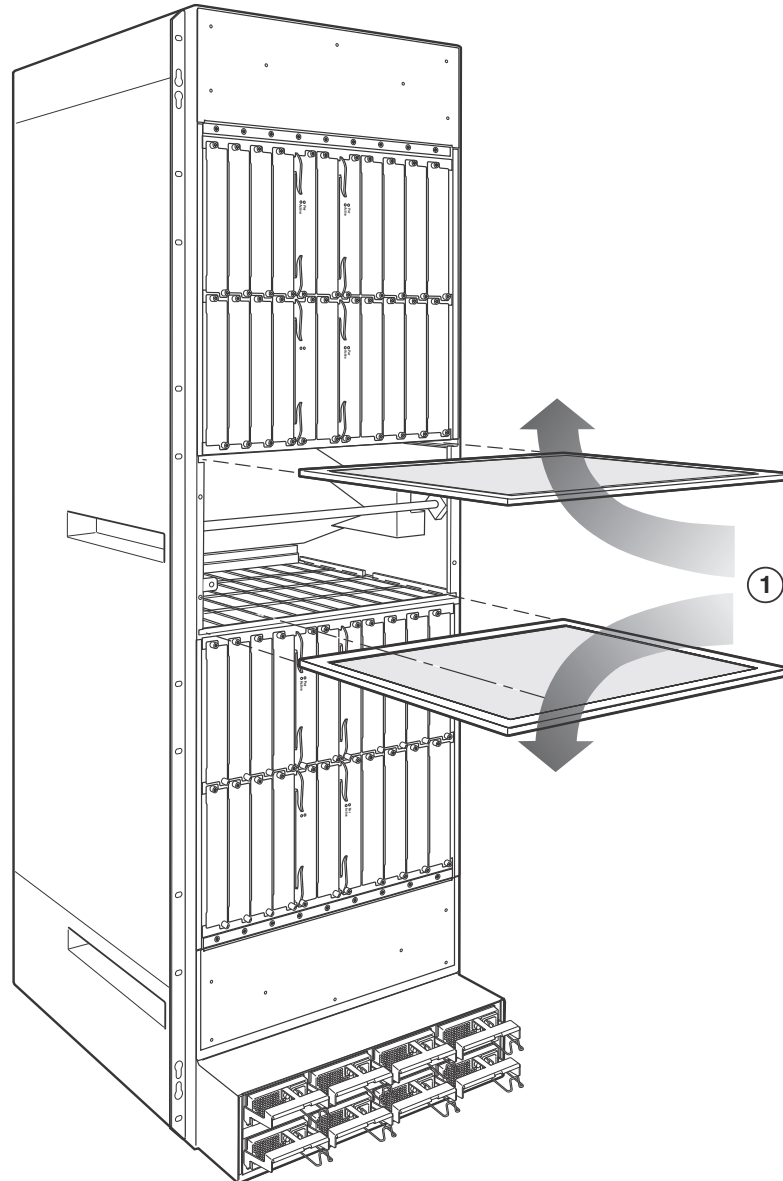

- 1 Direction of airflow in device

Replacing the air filter in Brocade MLXe 4-slot and 8-slot routers

Follow these steps to replace the air filter in Brocade MLXe 4-slot and 8-slot routers.

1. Loosen the two screws in the front of the filter tray.
2. Pull the filter tray away from the router as shown in [Figure 117](#) or [Figure 118](#).

FIGURE 117 Replacing an air filter in a Brocade MLXe 4-slot router.

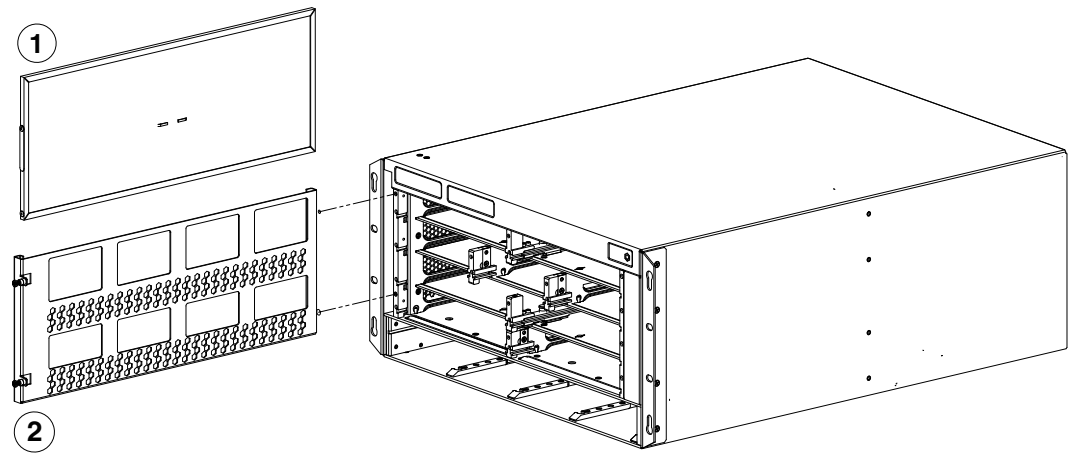

- 1 Air filter 2 Air filter tray

FIGURE 118 Air filter removal and replacement for the Brocade MLXe 8-slot router.

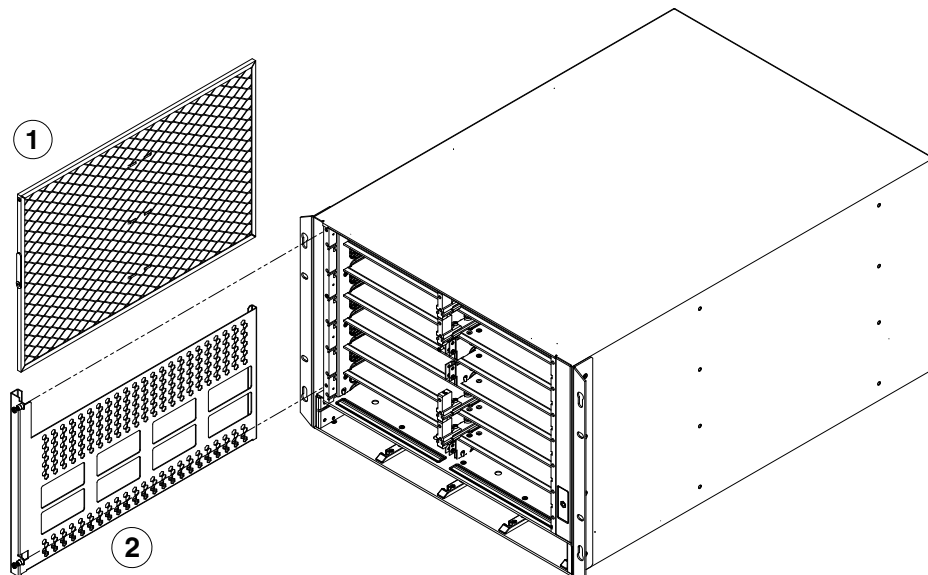

- 1 Air filter 2 Air filter tray

3. Remove the old air filter from the tray and discard it.
4. Insert the replacement air filter into the air filter tray.
5. Replace the filter tray in the router and tighten the two screws.

Replacing the air filter in Brocade MLXe 16-slot routers

Follow these steps to replace the air filter in a Brocade MLXe 16-slot router.

6 Replacing fan assemblies

1. Loosen the two screws in the front of the filter.
2. Pull the filter out of the router as shown in [Figure 119](#).

FIGURE 119 Replacing the air filter in a Brocade MLXe 16-slot routers

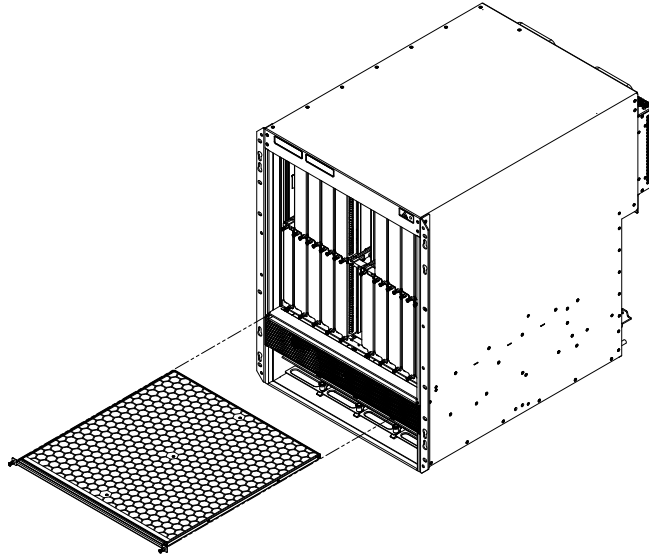

3. Remove the old filter from the chassis and discard the used filter.
4. Insert a new air filter into the filter slot and tighten the two screws.

Installing upward deflectors on fan assemblies

Before beginning this procedure, verify that you have the correct number of upward deflectors (part number 80-1004745-01). You can install up to eight deflectors on each router. You can remove each fan assembly while the router is running; however, you must not remove more than one fan assembly at any time to prevent the router from overheating.

NOTE

If the router is not receiving power, you can remove more than one fan assembly at a time.

It will take about one hour to complete this procedure for each Brocade MLXe-32 router.

The following items are required for this procedure:

- Phillips screwdriver
- Small flathead screwdriver
- ESD wrist strap



DANGER

For safety reasons, the ESD wrist strap should contain a 1 megohm series resistor.

Removing a fan assembly from the chassis

To remove a fan assembly from the chassis that is receiving power, complete the following steps:

1. Put on the ESD wrist strap and ground yourself by inserting the plug into the ESD connector on the router.
2. Depending on your router model (Brocade MLX-32 or Brocade MLXe-32) use the appropriate screwdriver to remove the screws that secure the fan assembly faceplate to the rear of the router.

**DANGER**

The 32-slot router fan assembly is heavy and will be off-balance as you remove it. Use both hands on the handle.

**DANGER**

Be careful not to insert your fingers into the fan while removing it from the device. The fan blades may still be spinning at a high speed.

**CAUTION**

Removing the rear fan modules on a 32-slot router provides access to bus bars and the backplane. Avoid contact with these parts. Hazardous energy levels exist at these locations.

3. Remove the fan assembly by grasping the handle on the faceplate and pulling the fan assembly toward you. Pulling the fan assembly unseats the fan connector from the router.

Attaching the upward deflector

The upward deflector is placed between the fan assembly handle and the fan assembly faceplate. To install the upward deflector to each fan assembly, complete the following steps:

1. Using a Phillips screwdriver, detach the fan assembly faceplate by removing the three screws from each side of the fan assembly. Refer to [Figure 113](#) on page 205.
2. If present, remove and discard the tape that stabilizes louvers in some fan assembly models. When present, the tape is located on the right and left sides of the fan assembly.

6 Replacing fan assemblies

FIGURE 120 Removing the fan assembly faceplate

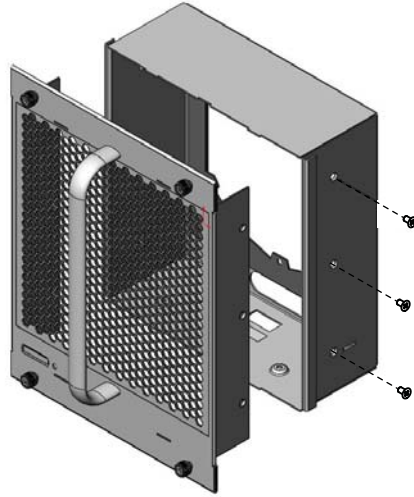
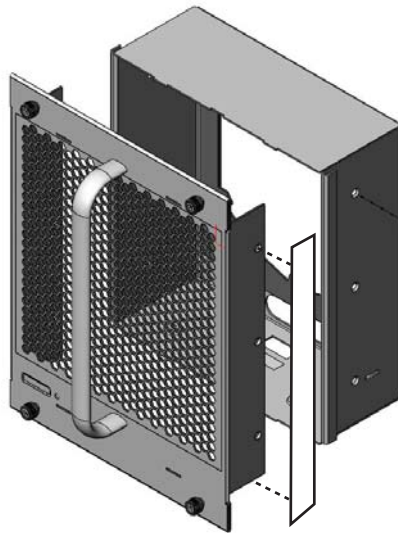
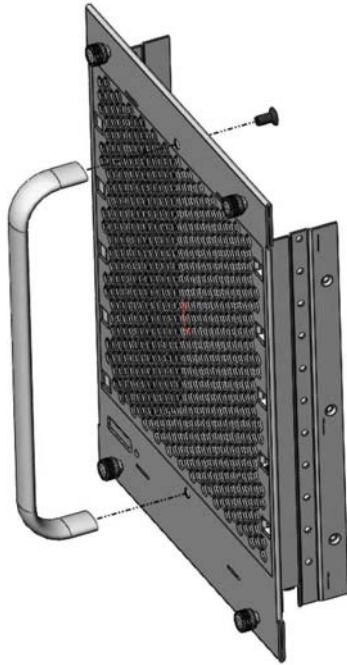

FIGURE 121 Removing tape from the fan assembly



3. Remove the fan assembly handle by detaching the two screws from the inside of the fan assembly faceplate using a Phillips screwdriver. Refer to [Figure 122](#).

FIGURE 122 Handle removal

4. Orient the upward deflector on the fan assembly faceplate so that the exhaust will flow upward and the holes in the upward deflector align with the holes where the screws secure the handle to the fan assembly faceplate. Refer to [Figure 122](#) in step 4.
5. Place the handle over the upward deflector aligning the handle with the screw holes and secure the handle to the upward deflector and fan assembly faceplate with the two screws. Refer to [Figure 123](#).

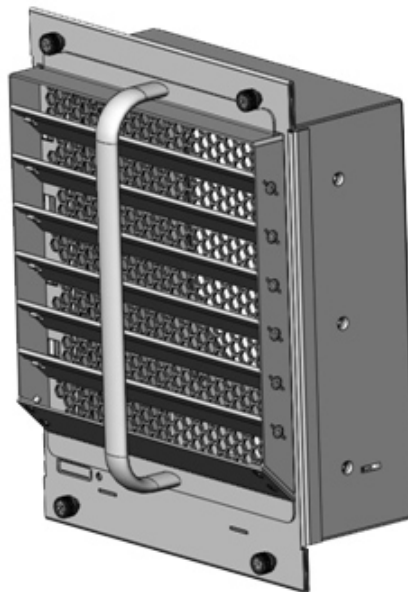
FIGURE 123 Upward deflector oriented correctly between the handle and fan assembly faceplate

6 Replacing fan assemblies

6. Re-attach the fan assembly faceplate to the fan assembly by securing three screws on each side.

NOTE

Replacing the tape is not required.

Reinstalling the modified fan assembly in the chassis

To reinstall the modified fan assembly, complete the following steps:

1. Insert the modified fan assembly into the fan slot and push the assembly in until the fan assembly faceplate is flush with the chassis. Pushing the fan assembly in seats the fan connector in the router connector.
2. Secure the fan assembly to the router by replacing and tightening the four screws.
3. Check the fan status LED in the lower left corner of the faceplate. It will glow red momentarily when power is applied, and then it will change to green when the fan comes up to speed.
4. To verify that the fan is operating correctly, access the CLI and enter the **show chassis** command.

Hardware Specifications

This chapter describes hardware specifications for Brocade MLXe routers.

Hardware specifications for Brocade MLXe routers

The following sections describe hardware specifications for Brocade MLXe routers.

Power specifications

The following power supply frequency requirements apply to Brocade MLXe-4, Brocade MLXe-8, and Brocade MLXe-16 routers:

- AC Input Rating: 100 to 240V, 50/60 Hz, 16.0 A maximum per power supply
 - 1200W Power Output for 1200W PSU (100-240V)
 - 1200W Power Output for 1800W PSU (100-180V)
 - 1800W Power Output for 1800W PSU (180-240V)
- AC Operating Voltage Range: 90 to 264V, 50/60 Hz
 - Inrush current <60A peak for any initial current surge or spike of 10mS or less at either cold or warm start. Any additional inrush current surges or spikes in the form of AC cycles or multiple AC cycles greater than 10mS and less than 150mS will be <25A peak.
- DC Input Rating: -48V
 - 40A maximum per power supply (1200W PSU)
 - 60A maximum per power supply (1800W PSU)
- DC Operating Range: -40 to -60V
 - Inrush current <80A peak for any initial current surge or spike of 10mS or less at either cold or warm start.

The following power supply frequency requirements apply to the Brocade MLXe 32-slot routers:

- AC Input Rating: 200 to 240V, 50/60 Hz, 16.0 A maximum per power supply
- AC Operating Voltage Range: 180 to 264V
 - Inrush current <60A peak for any initial current surge or spike of 10mS or less at either cold or warm start. Any additional inrush current surges or spikes in the form of AC cycles or multiple AC cycles greater than 10mS and less than 150mS will be <25A peak.
- DC Input Rating: -48V
 - 75A maximum per power supply (2400W PSU)
 - 80A maximum per power supply (3000W PSU)
- DC Operating Range: -40 to -60V
 - Inrush current <70A peak for any initial current surge or spike of 10mS or less at either cold or warm start.

NOTE

3000W power supplies do not support low line frequencies.

Table 37 lists power consumption, in watts, for Brocade MLXe router components.

TABLE 37 Maximum power consumption for Brocade MLXe router components

Component	Maximum power consumption, in watts
Management modules	
MR Management modules (MLXe-4, 8, and 16 routers)	30W
MR Management module (MLXe-32 routers)	35W
MR2 management module (BR-MLX-32-MR2-M for MLXe routers)	45W
MR2 management module (BR-MLX-MR2-M for MLXe routers)	40W
Switch fabric modules	
NI-X-SF3 switch fabric module	53W
NI-X-SF1 switch fabric module	19W
NI-X-32-SF switch fabric module	60W
High speed switch fabric modules	
NI-X-4-HSF switch fabric module (MLXe-4 routers)	19W
NI-X-16-8-HSF switch fabric module (MLXe-8 and MLXe-16 routers)	53W
NI-X-32-HSF switch fabric module (MLXe-32 routers)	60W
Interface modules	
1-port 100 Gbps Ethernet interface module	485W
2-port 100 Gbps Ethernet interface module	640W
2-port 10 Gbps Ethernet interface module (XMR routers)	
2-port 10 Gbps Ethernet interface module with fiber-optic transceivers (MLXe routers)	150W
4-port 10 Gbps Ethernet interface module with fiber-optic transceivers (MLXe routers)	225W
8-port 10 Gbps SFPP module (M)	246W
8-port 10 Gbps SFPP interface module (D)	246W
8-port 10 Gbps interface module (X)	270W
20-port Gbps Ethernet fiber Interface with fiber-optic transceivers (MLX routers)	175W
20-port Gbps Ethernet copper Interface module	146W
24-port 1 Gbps Ethernet copper RJ45 interface module	160W
24-port 1 Gbps Ethernet fiber interface module	160W
24-port 10 Gbps Ethernet interface module	320W
48-port Gbps Ethernet with MRJ-21 interface	260W

Table 38 lists power consumption information for Brocade MLXe routers with all base components installed, and with only the specified interface modules installed.

TABLE 38 Brocade MLXe router power consumption values

Model	@100 VAC			@200 VAC			@-48VDC			Minimum number of 1200W power supplies needed	Minimum number of 1800W power supplies needed	Minimum number of 2400W power supplies needed	Minimum number of 3000W power supplies needed
	Amps	Watts	BTU/hr	Amps	Watts	BTU/hr	Amps	Watts	BTU/hr				
MAXIMUM PER MLXe (using 8x10G-D, 8x10G-M, 4x10G, 2x10G, 1G modules only)													
MLXe-4	17	1730	5905	9	1730	5905	36	1730	5905	2	1		
MLXe-8	34	3356	11453	17	3356	11453	70	3356	11453	3	2		
MLXe-16	57	5698	19446	28	5698	19446	119	5698	19446	4	3		
MLXe-32	N/A	N/A	N/A	57	11414	38958	238	11414	38958			4	4
MAXIMUM PER MLXe (any module)													
MLXe-4	21	2083	7108	10	2083	7108	43	2083	7108	2	1		
MLXe-8	41	4060	13858	20	4060	13858	85	4060	13858	3	2		
MLXe-16	71	7107	24255	36	7107	24255	148	7107	24255	5	4		
MLXe-32	N/A	N/A	N/A	71	14232	48575	297	14232	48575			5	4

Physical dimensions

Table 39 provides the physical dimensions for Brocade MLXe routers.

TABLE 39 Brocade MLXe physical dimensions

Router model	Height	Width	Depth	Depth with Fan FRU	Weight (empty)	Weight (fully loaded)
Brocade MLXe-4	22.13 cm (8.714 in.)	43.69 cm (17.20 in.)	58.42 cm (23.0 in.)	63.5 cm (25.0 in.)	27.40 kg (60.4 lbs)	52.84 kg (116.5 lbs.)
Brocade MLXe-8	31.01 cm (12.21 in.)	43.69 cm (17.20 in.)	60.96 cm (24.0 in.)	66.04 cm (26.0 in.)	35.47 kg (78.2 lbs.)	77.72 kg (171.35 lbs.)
Brocade MLXe-16	62.15 cm (24.47 in.)	44.32 cm (17.45 in.)	64.77 cm (24.18 in.)	66.50 cm (26.18 in.)	41.66 kg (91.95 lbs.)	159.39 kg (351.4 lbs)
Brocade MLXe-32	146.58 cm (57.71 in.)	44.32 cm (17.45 in.)	61.21 cm (26.9 in.)	68.58 cm (27.0 in.)	128.68 kg (283.7 lbs.)	228.97 kg (504.8 lbs)

Operating environment

Table 40 provides the operating environment specifications for Brocade MLXe routers.

TABLE 40 Brocade MLXe router operating environment

Operating temperature	Relative humidity	Operating altitude
(0° - 40°C) 32° - 104°F	5 to 90%, at (40°C) 104°F, non-condensing	(0 - 3km) 0 - 10,000 ft

Storage environment

Table 41 provides the storage environment specifications for the Brocade MLXe routers.

TABLE 41 Brocade MLXe router storage environment

Storage temperature	Storage humidity	Storage altitude
(-25° – 70°C) -13° – 158°F	95% maximum relative humidity, non-condensing	(0 – 4500 meters) 0 – 15,000 ft

Safety agency approvals

- CAN/CSA-C22.2 No. 60950-1-07/UL60950-1 – Second Edition, Safety of Information Technology Equipment
- EN 60825-1 Safety of Laser Products – Part 1: Equipment Classification, Requirements and User’s Guide
- EN 60825-2 Safety of Laser Products – Part 2: Safety of Optical Fibre Communications Systems
- EN 60950-1:2006\IEC 60950-1:2005, Second Edition, Safety of Information Technology Equipment

Electromagnetic approvals

- FCC Part 15, Subpart B (Class A)
- EN 55022 (CE mark) (Class A)
- EN 55024 (CE mark) (Immunity) for Information Technology Equipment
- ICES-003 (Canada) (Class A)
- AS/NZ 55022 (Australia) (Class A)
- VCCI (Japan) (Class A)
- EN 61000-3-2
- EN 61000-3-3
- EN 61000-6-1

Port specifications for all router models

This section describes port specifications for all router models.

Console port pin assignments

The console port is a standard male DB-9 connector, as shown in [Figure 124](#). For information about how you can use this port, refer to [“Console port”](#) on page 11.

FIGURE 124 Console port pin and signalling details

Pin Assignment	Pin Number	Switch Signal
	1	Reserved
	2	TXD (output)
	3	RXD (input)
	4	Reserved
	5	GND
	6	Reserved
	7	Reserved
	8	Reserved
	9	Reserved

Most PC serial ports require a cable with a female DB-9 connector. Terminal connections will vary, requiring a cable with either a DB-9 or DB-25 connector, male or female.

Serial cable options between the router and a PC or terminal are shown in [Figure 125](#).

NOTE

As shown in [Figure 124](#) and [Figure 125](#), some wires should not be connected. If you connect wires that are labeled “Reserved”, you may experience unexpected results with some terminals.

FIGURE 125 Console port pin assignments with connection options to a terminal or PC

DB-9 to DB-9 Female Switch		Terminal or PC	DB-9 to DB-25 Female Switch		Terminal or PC
1	Reserved	1	1	Reserved	8
2	→	2	2	→	3
3	←	3	3	←	2
4	Reserved	4	4	Reserved	20
5	→	5	5	→	7
6	Reserved	6	6	Reserved	6
7	Reserved	7	7	Reserved	4
8	Reserved	8	8	Reserved	5
9	Reserved	9	9	Reserved	22

Management port pin assignments

The management port is an RJ45 UTP connector. [Table 42](#) describes the pin assignments for this connector. For information about how you can use this port, refer to “[10/100/1000 Ethernet port](#)” on page 11.

TABLE 42 Management port pin assignments

Pin number	MDI-X ports
1	TD+
2	TD-
3	RD+
4	Not used (10BaseT) CMT (100BaseTX)
5	Not used (10BaseT) CMT (100BaseTX)
6	RD-
7	Not used (10BaseT) CMT (100BaseTX)
8	Not used (10BaseT) CMT (100BaseTX)

Power cords

The types of power cords provided with routers are specific to the country where they are installed. To order a power cord, contact your Brocade supplier. [Table 43](#) describes power cord types.

TABLE 43 Power cord types (international)



Country	Plug style							
	NEMA 5-15P 125V for MLXe/MLX4, 8, 16-slot devices	NEMA 5-20P 125V. 16A for MLXe/MLX 4, 8, 16-slot devices	NEMA L6-20	CEE-7/7 “Schuko”	BS-1363A	AS 3112	IEC-60309 20A. 3-wire, 220 - 250V	NBR 14136
								
Argentina							X	
Australia						X		
Austria				X				
Bahrain					X			
Belgium				X				
Brazil								X
Canada	X	X						
Chile				X				
China, People’s Rep.						X		
Czech. Rep.				X				

TABLE 43 Power cord types (international) (Continued)





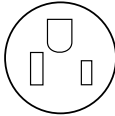
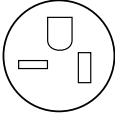
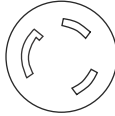
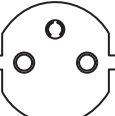
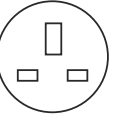
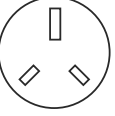

Country	Plug style							
	NEMA 5-15P 125V for MLXe/MLX 4, 8, 16-slot devices	NEMA 5-20P 125V. 16A for MLXe/MLX 4, 8, 16-slot devices	NEMA L6-20	CEE-7/7 “Schuko”	BS-1363A	AS 3112	IEC-60309 20A. 3-wire, 220 - 250V	NBR 14136
								
Denmark							X	
Egypt							X	
England							X	
Finland							X	
France				X				
Germany				X				
Greece				X				
Hong Kong					X			
Hungary					X			
India							X	
Indonesia				X				
Ireland, North					X			
Ireland, South					X			
Israel					X			
Italy							X	
Japan	X	X	X					
Korea, South				X				
Malaysia				Alternate			Recommended	
Mexico	X	X	X					
Monaco				X				
Netherlands				X				
New Zealand						X		
Norway							X	
Poland				X				
Portugal				X				
Puerto Rico	X	X	X					
Russia				X				
Saudi Arabia				X				

TABLE 43 Power cord types (international) (Continued)

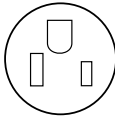
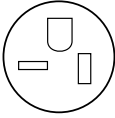
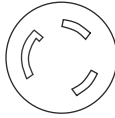
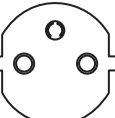
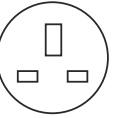
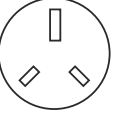
Country	Plug style							
	NEMA 5-15P 125V for MLXe/MLX 4, 8, 16-slot devices	NEMA 5-20P 125V. 16A for MLXe/MLX 4, 8, 16-slot devices	NEMA L6-20	CEE-7/7 "Schuko"	BS-1363A	AS 3112	IEC-60309 20A. 3-wire, 220 - 250V	NBR 14136
								
Scotland							X	
Singapore					X			
South Africa					X			
Spain				X				
Sweden							X	
Switzerland							X	
Taiwan	X	X	X					
Turkey				X				
United Arab Emirate				X				
United Kingdom							X	
United States		X	X					
Venezuela	X	X	X					
Yugoslavia				X				

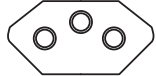
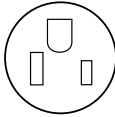
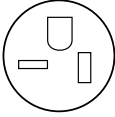
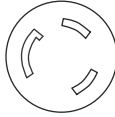
NOTE

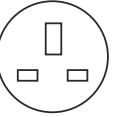
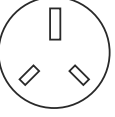
NEMA 5-15P should only be considered after taking into account the total power consumption on the system. Before you choose NEMA 5-15P on the system, calculate the total power consumption on the system to see whether NEMA 5-15P can support the power draw as per the country's legal requirements or contact Brocade technical support.

Brocade MLXe Chassis Bundles

The following tables describe the Brocade MLXe chassis bundles and their components.

TABLE 44 Brocade MLXe-4 chassis bundles

Part number	Hardware
BR-MLXE-4-AC	Bundle contents: <ul style="list-style-type: none"> • 1 Brocade MLXe-4 chassis • 2 high speed switch fabric modules (NI-X-4-HSF) • 1 1200W AC power supply (NI-X-ACPWR) • 4 exhaust fan assembly kits (BR-MLXE-4-FAN) • 1 air filter (BR-MLXE-4-FLTR) Management modules must be ordered separately. Power cord is not included.
BR-MLXE-4-DC	Bundle contents: <ul style="list-style-type: none"> • 1 Brocade MLXe-4 chassis • 2 high speed switch fabric modules (NI-X-4-HSF) • 1 1200W DC power supply (NI-X-DCPWR) • 4 exhaust fan assembly kits (BR-MLXE-4-FAN) • 1 air filter (BR-MLXE-4-FLTR) Management modules must be ordered separately. Power cord is not included.
BR-MLXE-4-MR-M-AC	Bundle contents: <ul style="list-style-type: none"> • 1 Brocade MLXe-4 AC chassis • 1 MR management module (NI-MLX-MR) • 2 high speed switch fabric modules (NI-X-4-HSF) • 1 1200W AC power supply (NI-X-ACPWR) • 4 exhaust fan assembly kits (BR-MLXE-4-FAN) • 1 air filter (BR-MLXE-4-FLTR) Power cord is not included.

A Brocade MLXe Chassis Bundles

Part number	Hardware
BR-MLXE-4-MR-M-DC	Bundle contents: <ul style="list-style-type: none"> • 1 Brocade MLXe-4 DC chassis • 1 MR management module (NI-MLX-MR) • 2 high speed switch fabric modules (NI-X-4-HSF) • 1 1200W DC power supply (NI-X-DCPWR) • 4 exhaust fan assembly kits (BR-MLXE-4-FAN) • 1 air filter (BR-MLXE-4-FLTR) Power cord is not included.
BR-MLXE-4-MR-X-AC	Bundle contents: <ul style="list-style-type: none"> • 1 Brocade MLXe-4 AC chassis • 1 MR management module (NI-XMR-MR) • 2 high speed switch fabric modules (NI-X-4-HSF) • 1 1200W AC power supply (NI-X-ACPWR) • 4 exhaust fan assembly kits (BR-MLXE-4-FAN) • 1 air filter (BR-MLXE-4-FLTR) Power cord is not included.
BR-MLXE-4-MR-X-DC	Bundle contents: <ul style="list-style-type: none"> • 1 Brocade MLXe-4 AC chassis • 1 MR management module (NI-XMR-MR) • 2 high speed switch fabric modules (NI-X-4-HSF) • 1 1200W DC power supply (NI-X-DCPWR) • 4 exhaust fan assembly kits (BR-MLXE-4-FAN) • 1 air filter (BR-MLXE-4-FLTR) Power cord is not included.
BR-MLXE-4-MR2-M-AC	Bundle contents: <ul style="list-style-type: none"> • 1 Brocade MLXe-4 AC chassis • 1 MR2 (M) management module (BR-MLX-MR2-M) • 2 high speed switch fabric modules (NI-X-4-HSF) • 1 1800W AC power supply (BR-MLXE-ACPWR-1800) • 4 exhaust fan assembly kits (BR-MLXE-4-FAN) • 1 air filter (BR-MLXE-4-FLTR) Power cord is not included.

Part number	Hardware
BR-MLXE-4-MR2-M-DC	Bundle contents: <ul style="list-style-type: none"> • 1 Brocade MLXe-4 DC chassis • 1 MR2 (M) management module (BR-MLX-MR2-M) • 2 high speed switch fabric modules (NI-X-4-HSF) • 1 1800W DC power supply (BR-MLXE-DCPWR-1800) • 4 exhaust fan assembly kits (BR-MLXE-4-FAN) • 1 air filter (BR-MLXE-4-FLTR) Power cord is not included.
BR-MLXE-4-MR2-X-AC	Bundle contents: <ul style="list-style-type: none"> • 1 Brocade MLXe-4 AC chassis • 1 MR2 (X) management module (BR-MLX-MR2-X) • 2 high speed switch fabric modules (NI-X-4-HSF) • 1 1800W AC power supply (BR-MLXE-ACPWR-1800) • 4 exhaust fan assembly kits (BR-MLXE-4-FAN) • 1 air filter (BR-MLXE-4-FLTR) Power cord is not included.
BR-MLXE-4-MR2-X-DC	Bundle contents: <ul style="list-style-type: none"> • 1 Brocade MLXe-4 DC chassis • 1 MR2 (X) management module (BR-MLX-MR2-X) • 2 high speed switch fabric modules (NI-X-4-HSF) • 1 1800W DC power supply (BR-MLXE-DCPWR-1800) • 4 exhaust fan assembly kits (BR-MLXE-4-FAN) • 1 air filter (BR-MLXE-4-FLTR) Power cord is not included.

TABLE 45 Brocade MLXe-8 chassis bundles

Part number	Hardware
BR-MLXE-8-AC	<p>Bundle contents:</p> <ul style="list-style-type: none"> • 1 Brocade MLXe-8 chassis • 2 high speed switch fabric modules (NI-X-16-8-HSF) • 2 1200W AC power supplies (NI-X-ACPWR) • 2 exhaust fan assembly kits (BR-MLXE-8-FAN) • 1 air filter (BR-MLXE-8-FLTR) <p>Management modules must be ordered separately.</p> <p>Power cord is not included.</p>
BR-MLXE-8-DC	<p>Bundle contents:</p> <ul style="list-style-type: none"> • 1 Brocade MLXe-8 chassis • 2 high speed switch fabric modules (NI-X-16-8-HSF) • 2 1200W DC power supplies (NI-X-DCPWR) • 2 exhaust fan assembly kits (BR-MLXE-8-FAN) • 1 air filter (BR-MLXE-8-FLTR) <p>Management modules must be ordered separately.</p> <p>Power cord is not included.</p>
BR-MLXE-8-MR-M-AC	<p>Bundle contents:</p> <ul style="list-style-type: none"> • 1 Brocade MLXe-8 AC chassis • 1 MR management module (NI-MLX-MR) • 2 high speed switch fabric modules (NI-X-16-8-HSF) • 2 1200W AC power supply (NI-X-ACPWR) • 2 exhaust fan assembly kits (BR-MLXE-8-FAN) • 1 air filter (BR-MLXE-8-FLTR) <p>Power cord is not included.</p>
BR-MLXE-8-MR-M-DC	<p>Bundle contents:</p> <ul style="list-style-type: none"> • 1 Brocade MLXe-8 DC chassis • 1 MR management module (NI-MLX-MR) • 2 high speed switch fabric modules (NI-X-16-8-HSF) • 2 1200W DC power supply (NI-X-DCPWR) • 2 exhaust fan assembly kits (BR-MLXE-8-FAN) • 1 air filter (BR-MLXE-8-FLTR) <p>Power cord is not included.</p>

Part number	Hardware
BR-MLXE-8-MR-X-AC	<p>Bundle contents:</p> <ul style="list-style-type: none"> • 1 Brocade MLXe-8 AC chassis • 1 MR management module (NI-XMR-MR) • 2 high speed switch fabric modules (NI-X-16-8-HSF) • 2 1200W AC power supply (NI-X-ACPWR) • 2 exhaust fan assembly kits (BR-MLXE-8-FAN) • 1 air filter (BR-MLXE-8-FLTR) <p>Power cord is not included.</p>
BR-MLXE-8-MR-X-DC	<p>Bundle contents:</p> <ul style="list-style-type: none"> • 1 Brocade MLXe-8 DC chassis • 1 MR management module (NI-XMR-MR) • 2 high speed switch fabric modules (NI-X-16-8-HSF) • 2 1200W DC power supply (NI-X-DCPWR) • 2 exhaust fan assembly kits (BR-MLXE-8-FAN) • 1 air filter (BR-MLXE-8-FLTR) <p>Power cord is not included.</p>
BR-MLXE-8-MR2-M-AC	<p>Bundle contents:</p> <ul style="list-style-type: none"> • 1 Brocade MLXe-8 AC chassis • 1 MR2 (M) management module (BR-MLX-MR2-M) • 2 high speed switch fabric modules (NI-X-4-HSF) • 2 1800W AC power supplies (BR-MLXE-ACPWR-1800) • 2 exhaust fan assembly kits (BR-MLXE-8-FAN) • 1 air filter (BR-MLXE-8-FLTR) <p>Power cord is not included.</p>
BR-MLXE-8-MR2-M-DC	<p>Bundle contents:</p> <ul style="list-style-type: none"> • 1 Brocade MLXe-8 DC chassis • 1 MR2 (M) management module (BR-MLX-MR2-M) • 2 high speed switch fabric modules (NI-X-4-HSF) • 2 1800W DC power supplies (BR-MLXE-DCPWR-1800) • 2 exhaust fan assembly kits (BR-MLXE-8-FAN) • 1 air filter (BR-MLXE-8-FLTR) <p>Power cord is not included.</p>

A Brocade MLXe Chassis Bundles

Part number	Hardware
BR-MLXE-8-MR2-X-AC	<p>Bundle contents:</p> <ul style="list-style-type: none">• 1 Brocade MLXe-8 AC chassis• 1 MR2 (X) management module (BR-MLX-MR2-X)• 2 high speed switch fabric modules (NI-X-4-HSF)• 2 1800W AC power supplies (BR-MLXE-ACPWR-1800)• 2 exhaust fan assembly kits (BR-MLXE-8-FAN)• 1 air filter (BR-MLXE-8-FLTR) <p>Power cord is not included.</p>
BR-MLXE-8-MR2-X-DC	<p>Bundle contents:</p> <ul style="list-style-type: none">• 1 Brocade MLXe-8 DC chassis• 1 MR2 (X) management module (BR-MLX-MR2-X)• 2 high speed switch fabric modules (NI-X-4-HSF)• 2 1800W DC power supplies (BR-MLXE-DCPWR-1800)• 2 exhaust fan assembly kits (BR-MLXE-8-FAN)• 1 air filter (BR-MLXE-8-FLTR) <p>Power cord is not included.</p>

TABLE 46 Brocade MLXe-16 chassis bundles

Part number	Hardware
BR-MLXE-16-AC	<p>Bundle contents:</p> <ul style="list-style-type: none"> • 1 Brocade MLXe-16 chassis • 3 high speed switch fabric modules (NI-X-16-8-HSF) • 4 1200W AC power supplies (NI-X-ACPWR) • 2 exhaust fan assembly kits (BR-MLXE-16-FAN) • 1 air filter (BR-MLXE-16-FLTR) <p>Management modules must be ordered separately.</p> <p>Power cord is not included.</p>
BR-MLXE-16-DC	<p>Bundle contents:</p> <ul style="list-style-type: none"> • 1 Brocade MLXe-16 chassis • 3 high speed switch fabric modules (NI-X-16-8-HSF) • 4 1200W DC power supplies (NI-X-DCPWR) • 2 exhaust fan assembly kits (BR-MLXE-16-FAN) • 1 air filter (BR-MLXE-16-FLTR) <p>Management modules must be ordered separately.</p> <p>Power cord is not included.</p>
BR-MLXE-16-MR-M-AC	<p>Bundle contents:</p> <ul style="list-style-type: none"> • 1 Brocade MLXe-16 AC chassis • 1 MR management module (NI-MLX-MR) • 3 high speed switch fabric modules (NI-X-16-8-HSF) • 4 1200W AC power supply (NI-X-ACPWR) • 2 exhaust fan assembly kits (BR-MLXE-16-FAN) • 1 air filter (BR-MLXE-16-FLTR) <p>Power cord is not included.</p>
BR-MLXE-16-MR-M-DC	<p>Bundle contents:</p> <ul style="list-style-type: none"> • 1 Brocade MLXe-16 DC chassis • 1 MR management module (NI-MLX-MR) • 3 high speed switch fabric modules (NI-X-16-8-HSF) • 4 1200W DC power supply (NI-X-ACPWR) • 2 exhaust fan assembly kits (BR-MLXE-16-FAN) • 1 air filter (BR-MLXE-16-FLTR) <p>Power cord is not included.</p>

TABLE 46 Brocade MLXe-16 chassis bundles (Continued)

Part number	Hardware
BR-MLXE-16-MR-X-AC	Bundle contents: <ul style="list-style-type: none"> • 1 Brocade MLXe-16 AC chassis • 1 MR management module (NI-XMR-MR) • 3 high speed switch fabric modules (NI-X-16-8-HSF) • 4 1200W AC power supply (NI-X-ACPWR) • 2 exhaust fan assembly kits (BR-MLXE-16-FAN) • 1 air filter (BR-MLXE-16-FLTR) Power cord is not included.
BR-MLXE-16-MR-X-DC	Bundle contents: <ul style="list-style-type: none"> • 1 Brocade MLXe-16 DC chassis • 1 MR management module (NI-XMR-MR) • 3 high speed switch fabric modules (NI-X-16-8-HSF) • 4 1200W DC power supply (NI-X-ACPWR) • 2 exhaust fan assembly kits (BR-MLXE-16-FAN) • 1 air filter (BR-MLXE-16-FLTR) Power cord is not included.
BR-MLXE-16-MR2-M-AC	Bundle contents: <ul style="list-style-type: none"> • 1 Brocade MLXe-16 AC chassis • 1 MR2 (M) management module (BR-MLX-MR2-M) • 3 high speed switch fabric modules (NI-X-4-HSF) • 4 1800W AC power supplies (BR-MLXE-ACPWR-1800) • 2 exhaust fan assembly kits (BR-MLXE-16-FAN) • 1 air filter (BR-MLXE-16-FLTR) Power cord is not included.
BR-MLXE-16-MR2-M-DC	Bundle contents: <ul style="list-style-type: none"> • 1 Brocade MLXe-16 DC chassis • 1 MR2 (M) management module (BR-MLX-MR2-M) • 3 high speed switch fabric modules (NI-X-4-HSF) • 4 1800W DC power supplies (BR-MLXE-DCPWR-1800) • 2 exhaust fan assembly kits (BR-MLXE-16-FAN) • 1 air filter (BR-MLXE-16-FLTR) Power cord is not included.

TABLE 46 Brocade MLXe-16 chassis bundles (Continued)

Part number	Hardware
BR-MLXE-16-MR2-X-AC	Bundle contents: <ul style="list-style-type: none"> • 1 Brocade MLXe-16 AC chassis • 1 MR2 (X) management module (BR-MLX-MR2-X) • 3 high speed switch fabric modules (NI-X-4-HSF) • 4 1800W AC power supplies (BR-MLXE-ACPWR-1800) • 2 exhaust fan assembly kits (BR-MLXE-16-FAN) • 1 air filter (BR-MLXE-16-FLTR) Power cord is not included.
BR-MLXE-16-MR2-X-DC	Bundle contents: <ul style="list-style-type: none"> • 1 Brocade MLXe-16 DC chassis • 1 MR2 (X) management module (BR-MLX-MR2-X) • 3 high speed switch fabric modules (NI-X-4-HSF) • 4 1800W DC power supplies (BR-MLXE-DCPWR-1800) • 2 exhaust fan assembly kits (BR-MLXE-16-FAN) • 1 air filter (BR-MLXE-16-FLTR) Power cord is not included.

TABLE 47 Brocade MLXe-32 chassis bundles

Part number	Hardware
BR-MLXE-32-AC	<p>Bundle contents:</p> <ul style="list-style-type: none"> • 1 Brocade MLXe-32 chassis • 7 high speed switch fabric modules (NI-X-32-HSF) • 4 2400W AC power supplies (NIBI-32-ACPWR-A) • 2 power supply fans (NIBI-32-PSFAN) • 8 exhaust fan assembly kits (BR-MLXE-32-FAN) • 2 air filters (BR-MLXE-32-FLTR) • Cable management system <p>Management modules must be ordered separately.</p> <p>Power cord is not included.</p>
BR-MLXE-32-DC	<p>Bundle contents:</p> <ul style="list-style-type: none"> • 1 Brocade MLXe-32 chassis • 7 high speed switch fabric modules (NI-X-32-HSF) • 4 2400W DC power supplies (NIBI-32-DCPWR) • 2 power supply fans (NIBI-32-PSFAN) • 8 exhaust fan assembly kits (BR-MLXE-32-FAN) • 2 air filters (BR-MLXE-32-FLTR) • Cable management system <p>Management modules must be ordered separately.</p> <p>Power cord is not included.</p>
BR-MLXE-32-MR-M-AC	<p>Bundle contents:</p> <ul style="list-style-type: none"> • 1 Brocade MLXe-32 AC chassis • 1 MR management module (NI-MLX-32-MR) • 7 high speed switch fabric modules (NI-X-32-HSF) • 4 2400W AC power supplies (NIBI-32-ACPWR-A) • 2 power supply fans (NIBI-32-PSFAN) • 8 exhaust fan assembly kits (BR-MLXE-32-FAN) • 2 air filters (BR-MLXE-32-FLTR) • Cable management system <p>Power cord is not included.</p>

Part number	Hardware
BR-MLXE-32-MR-M-DC	Bundle contents: <ul style="list-style-type: none"> • 1 Brocade MLXe-32 DC chassis • 1 MR management module (NI-MLX-32-MR) • 7 high speed switch fabric modules (NI-X-32-HSF) • 4 2400W DC power supplies (NIBI-32-DCPWR) • 2 power supply fans (NIBI-32-PSFAN) • 8 exhaust fan assembly kits (BR-MLXE-32-FAN) • 2 air filters (BR-MLXE-32-FLTR) • Cable management system Power cord is not included.
BR-MLXE-32-MR-X-AC	Bundle contents: <ul style="list-style-type: none"> • 1 Brocade MLXe-32 AC chassis • 1 MR management module (BR-MLX-32-MR) • 7 high speed switch fabric modules (NI-X-32-HSF) • 4 2400W AC power supplies (NIBI-32-ACPWR-A) • 2 power supply fans (NIBI-32-PSFAN) • 8 exhaust fan assembly kits (BR-MLXE-32-FAN) • 2 air filters (BR-MLXE-32-FLTR) • Cable management system Power cord is not included.
BR-MLXE-32-MR-X-DC	Bundle contents: <ul style="list-style-type: none"> • 1 Brocade MLXe-32 DC chassis • 1 MR management module (BR-MLX-32-MR) • 7 high speed switch fabric modules (NI-X-32-HSF) • 4 2400W DC power supplies (NIBI-32-DCPWR) • 2 power supply fans (NIBI-32-PSFAN) • 8 exhaust fan assembly kits (BR-MLXE-32-FAN) • 2 air filters (BR-MLXE-32-FLTR) • Cable management system Power cord is not included.

A Brocade MLXe Chassis Bundles

Part number	Hardware
BR-MLXE-32-MR2-M-AC	<p>Bundle contents:</p> <ul style="list-style-type: none">• 1 Brocade MLXe-32 AC chassis• 1 MR2 (M) management module (BR-MLX-32-MR2-M)• 7 high speed switch fabric modules (NI-X-32-HSF)• 4 3000W AC power supplies (BR-MLXE-32-ACPWR-3000)• 2 power supply fans (NIBI-32-PSFAN)• 8 exhaust fan assembly kits (BR-MLXE-32-FAN)• 2 air filters (BR-MLXE-32-FLTR)• Cable management system <p>Power cord is not included.</p>
BR-MLXE-32-MR2-M-DC	<p>Bundle contents:</p> <ul style="list-style-type: none">• 1 Brocade MLXe-32 DC chassis• 1 MR2 (M) management module (BR-MLX-32-MR2-M)• 7 high speed switch fabric modules (NI-X-32-HSF)• 4 3000W DC power supplies (BR-MLXE-32-DCPWR-3000)• 2 power supply fans (NIBI-32-PSFAN)• 8 exhaust fan assembly kits (BR-MLXE-32-FAN)• 2 air filters (BR-MLXE-32-FLTR)• Cable management system <p>Power cord is not included.</p>

Part number	Hardware
BR-MLXE-32-MR2-X-AC	Bundle contents: <ul style="list-style-type: none"> • 1 Brocade MLXe-32 AC chassis • 1 MR2 (X) management module (BR-MLX-32-MR2-X) • 7 high speed switch fabric modules (NI-X-32-HSF) • 4 3000W AC power supplies (BR-MLXE-32-ACPWR-3000) • 2 power supply fans (NIBI-32-PSFAN) • 8 exhaust fan assembly kits (BR-MLXE-32-FAN) • 2 air filters (BR-MLXE-32-FLTR) • Cable management system Power cord is not included.
BR-MLXE-32-MR2-X-DC	Bundle contents: <ul style="list-style-type: none"> • 1 Brocade MLXe-32 DC chassis • 1 MR2 (X) management module (BR-MLX-32-MR2-X) • 7 high speed switch fabric modules (NI-X-32-HSF) • 4 3000W DC power supplies (BR-MLXE-32-DCPWR-3000) • 2 power supply fans (NIBI-32-PSFAN) • 8 exhaust fan assembly kits (BR-MLXE-32-FAN) • 2 air filters (BR-MLXE-32-FLTR) • Cable management system Power cord is not included.

A Brocade MLXe Chassis Bundles

Regulatory Statements

U.S.A.

This equipment has been tested and found to comply with the limits for a Class A digital device pursuant to Part 15 of the FCC Rules. These limits are designed to provide reasonable protection against harmful interference when the equipment is operated in a commercial environment. This equipment generates, uses, and can radiate radio frequency energy and, if not installed and used in accordance with the instruction manual, may cause harmful interference to radio communications. Operation of this equipment in a residential area is likely to cause harmful interference in which case the user will be required to correct the interference at his own expense.



CAUTION

Changes or modifications made to this device which are not expressly approved by the party responsible for compliance could void the user's authority to operate the equipment.

Industry Canada statement

This Class A digital apparatus complies with Canadian ICES-003.

Cet appareil numérique de la classe A est conforme à la norme NMB-003 du Canada.

Europe and Australia

This is a Class A product. In a domestic environment this product may cause radio interference in which case the user may be required to take adequate measures.

Germany

For Brocade MLXe-32 routers:

Machine noise information regulation - 3. GPSGV, the highest sound pressure level value is 88.4 dB(A) in accordance with EN ISO 7779.

Maschinenlärminformations-Verordnung - 3. GPSGV, der höchste Schalldruckpegel beträgt 88.4 dB(A) gemäss EN ISO 7779.

For Brocade MLXe-16 routers:

Machine noise information regulation - 3. GPSGV, the highest sound pressure level value is 89 dB(A) in accordance with EN ISO 7779.

B Japan

Maschinenlärminformations-Verordnung - 3. GPSGV, der höchste Schalldruckpegel beträgt 89 dB(A) gemäss EN ISO 7779.

For Brocade MLXe-8 routers:

Machine noise information regulation - 3. GPSGV, the highest sound pressure level value is 87.4 dB(A) in accordance with EN ISO 7779.

Maschinenlärminformations-Verordnung - 3. GPSGV, der höchste Schalldruckpegel beträgt 87.4 dB(A) gemäss EN ISO 7779.

For Brocade MLXe-4 routers:

Machine noise information regulation - 3. GPSGV, the highest sound pressure level value is 86 dB(A) in accordance with EN ISO 7779.

Maschinenlärminformations-Verordnung - 3. GPSGV, der höchste Schalldruckpegel beträgt 86 dB(A) gemäss EN ISO 7779.

Japan

この装置は、情報処理装置等電波障害自主規制協議会（VCCI）の基準に基づくクラス A 情報技術装置です。この装置を家庭環境で使用すると電波妨害を引き起こすことがあります。この場合には使用者が適切な対策を講ずるよう要求されることがあります。

English translation of above statement

This is Class A product based on the standard of the Voluntary Control Council For Interference by Information Technology Equipment (VCCI). If this equipment is used in a domestic environment, radio disturbance may arise. When such trouble occurs, the user may be required to take corrective actions.

Power cords (Japan Denan)



注意 - 添付の電源コードを他の装置や用途に使用しない

添付の電源コードは本装置に接続し、使用することを目的として設計され、その安全性が確認されているものです。決して他の装置や用途に使用しないでください。火災や感電の原因となる恐れがあります。

English translation of above statement

ATTENTION: Never use the power cord packed with your equipment for other products.

China

The following statement applies to Brocade MLX Series and Brocade NetIron XMR devices.

声 明

此为 A 级产品，在生活环境中，该产品可能会造成无线电干扰。在这种情况下，可能需要用户对其干扰采取切实可行的措施。

English translation of above statement

This is a class A product. In a domestic environment this product may cause radio interference in which case the user may be required to take adequate measures

Taiwan

警告使用者：
這是甲類的資訊產品，在居住的環境中使用時，可能會造成射頻干擾，
在這種情況下，使用者會被要求採取某些適當的對策。

English translation of above statement

Warning:

This is Class A product. In a domestic environment this product may cause radio interference in which case the user may be required to take adequate measures.

Korea

A 급 기기 (업무용 방송통신기기): 이 기기는 업무용 (A 급) 으로 전자파적합등록을 한 기기이오니 판매자 또는 사용자는 이 점을 주의하시기 바라며, 가정외의 지역에서 사용하는 것을 목적으로 합니다.

English translation of above statement

Class A device (Broadcasting Communication Device for Office Use): This device obtained EMC registration for office use (Class A), and may be used in places other than home. Sellers and/or users need to take note of this.

Russia

Сертификат Соответствия в "Системе сертификации в области связи" № ОС-2-СПД-0561, срок действия: с 29 октября 2009 г. до 29 октября 2012 г.

English Translation of above statement

Certificate of Conformity in "Certification System in the field of telecommunications" # ??-2-???-0561, validity from the 29 of October 2009 to the 29 of October 2012.

Brazil

The following Brocade products are currently certified by Anatel:

- Brocade MLX-4
- Brocade MLX-8,
- Brocade MLX-16
- Brocade MLX-32
- Brocade NetIron XMR 4000
- Brocade NetIron XMR 8000
- Brocade NetIron XMR 16000
- Brocade NetIron XMR 32000

All certificates can be found at the Anatel web site.

NOTE

For regulatory purposes, the Brocade MLX-4 and Brocade NetIron XMR 4000 are identified by model number BI-RX-4. The Brocade MLX-8 and Brocade NetIron XMR 8000 are identified by model number BI-RX-8. The Brocade MLX-16 and Brocade NetIron XMR 16000 are identified by model number BI-RX-16. The Brocade MLX-32 and Brocade NetIron XMR 32000 are identified by model number BI-RX-32.

TABLE 48 Anatel certificates

Model number	Certificate number
BI-RX-08	1786-09-5661
BI-RX-16	1784-09-5661
BI-RX-04	1785-09-5661
BI-RX-32	1787-09-5661

B Brazil

Caution and Danger Notices

Cautions

The cautions and dangers that appear in this manual are listed below in English, German, French, and Spanish.

A caution calls your attention to a possible hazard that can damage equipment.

"Vorsicht" weist auf eine mögliche Beschädigung des Geräts hin. Sie finden die folgenden Vorsichtshinweise in diesem Handbuch.

Une mise en garde attire votre attention sur un risque possible d'endommagement de l'équipement. Ci-dessous, vous trouverez les mises en garde utilisées dans ce manuel.

Un mensaje de precaución le advierte sobre un posible peligro que pueda dañar el equipo. Las siguientes son precauciones utilizadas en este manual.

CAUTION	All devices with DC power supplies (Brocade NetIron XMR 4000, 8000, 16000, and 32000, Brocade MLX-4, -8, -16, and -32, and Brocade MLXe-16, and -32) are intended for installation in restricted access areas only. A restricted access area is where access can be gained only by service personnel through the use of a special tool, lock and key, or other means of security, and is controlled by the authority responsible for the location.
VORSICHT	Alle Geräte mit Direktstromquellen (Brocade NetIron XMR 4000, 8000, 16000, und 32000, Brocade MLX-4, -8, -16, und -32, und Brocade MLXe-16, und -32) sind nur zur Installation in Sperrbereichen bestimmt. Ein Sperrbereich ist ein Ort, zu dem nur Wartungspersonal mit einem Spezialwerkzeug, Schloss und Schlüssel oder einer anderen Schutzvorrichtung Zugang hat. Er unterliegt außerdem der Kontrolle durch die für den Standort verantwortliche Stelle.
MISE EN GARDE	Tous les équipements dotés d'un bloc d'alimentation en courant continu (Brocade NetIron XMR 4000, 8000, 16000, et 32000, Brocade MLX-4, -8, -16, et -32, et Brocade MLXe-16, and -32) sont conçus pour l'installation dans des zones à accès réglementé uniquement. Une zone à accès réglementé est un local qui n'est accessible que par le personnel d'entretien à l'aide d'un outil, verrou ou clé conçus à cet effet, ou de tout autre accessoire de sécurité, et qui est contrôlé par l'autorité responsable de ce local.
PRECAUCIÓN	Todos aquellos dispositivos con fuentes de alimentación de CC (Brocade NetIron XMR 4000, 8000, 16000, y 32000, Brocade MLX-4, -8, -16, y -32, y Brocade MLXe-16, y -32) están diseñados para su instalación en zonas de acceso restringido solamente. Una zona de acceso restringido es un lugar al que sólo puede acceder personal de mantenimiento haciendo uso de una herramienta especial, una llave y un candado, o algún otro medio de seguridad, y que está controlado por la autoridad responsable.

C Cautions

CAUTION	For a DC system (Brocade NetIron XMR 4000, 8000, and 16000, Brocade MLX-4, -8, and -16, and Brocade MLXe-16), use a grounding wire of at least 6 American Wire Gauge (AWG). The 6 AWG wire should be attached to an agency-approved crimp connector (provided on the chassis), and crimped with the proper tool. The crimp connector should allow for securement to both ground screws on the enclosure. For the ground lug use a UL-listed Panduit crimp connector, P/N LCD6-10A, and two 10-32, PPH, 1/2 screws to secure crimp connector to chassis. The grounding position is located on the side of the chassis adjacent to the ground symbol.
VORSICHT	Für ein Gleichstromsystem (Brocade NetIron XMR 4000, 8000, und 16000, Brocade MLX-4, -8, und -16, und Brocade MLXe-16) ist ein Erdleiter von mindestens 6 AWG (amerikanische Norm für Drahtquerschnitte) zu verwenden. Der 6-AWG-Leiter sollte an einem geprüften gecrimpten Anschluss (am Brocade MLX-16 und Brocade MLXe-16 Chassis bereitgestellt) angebracht und mit dem vorschriftsmäßigen Werkzeug gecrimpt werden. Der gecrimpte Anschluss sollte eine Sicherung an beiden Erdungsschrauben am Gehäuse ermöglichen. Für Brocade MLX-8 und Brocade MLX-4 ist ein Erdleiter von mindestens 6 AWG (American Wire Gauge) zu verwenden. Für den Erdungskabelschuh ist ein UL-geprüfter Panduit-Crimp-Anschluss (Best.-Nr. LCD6-10A) und zwei 10-32, PPH, 1/2-Schrauben zur Sicherung des Crimp-Anschlusses am Chassis zu verwenden. Die Erdungsposition befindet sich seitlich am Chassis neben dem Erdungssymbol.
MISE EN GARDE	Pour un système à alimentation continue (Brocade NetIron XMR 4000, 8000, et 16000, Brocade MLX-4, -8, et -16, et Brocade MLXe-16), utiliser un câble de mise à la terre de calibre 13.29 mm ² au minimum. Le conducteur de 13.29 mm ² doit être fixé à un raccord à sertir agréé (directement présent sur le châssis du Brocade MLX-16 et Brocade MLXe-16) à l'aide de la pince à sertir appropriée. Le raccord à sertir doit pouvoir être raccordé aux deux vis de mise à la terre du châssis. Pour les Brocade MLX-8 et Brocade MLX-4, utiliser un câble de mise à la terre de calibre 13.29 mm ² au minimum. Pour la borne de mise à la terre, utiliser un raccord à sertir Panduit agréé (réf. LCD6-10A). Pour fixer ce raccord au châssis, utiliser deux 1/2 vis 10-32 PPH. L'emplacement prévu pour la mise à la terre, identifié par le symbole international correspondant, se trouve sur le côté du châssis.
PRECAUCIÓN	Para un sistema de CC (Brocade NetIron XMR 4000, 8000, y 16000, Brocade MLX-4, -8, y -16, y Brocade MLXe-16), utilice un conductor de tierra de al menos 6 CAE (Calibre de Alambre Estadounidense, American Wire Gauge o AWG en sus siglas en inglés). El conductor de 6 CAE debe estar acoplado a un conector rizado homologado (suministrado con el chasis Brocade MLX-16 y Brocade MLXe-16), que haya sido rizado con la herramienta apropiada. El conector rizado debe permitir el acoplamiento a los dos tornillos de tierra del recinto. Para los sistemas Brocade MLX-8 y Brocade MLX-4, utilice un conductor de tierra de al menos 6 CAE. Para el terminal de tierra, utilice un conector rizado Panduit homologado por UL, P/N LCD6-10A, y dos tornillos 1/2, PPH, 10-32 para fijar el conector rizado al chasis. La posición de conexión a tierra está situada en el lateral del chasis junto al símbolo de tierra.

CAUTION	For the DC input circuit to the system of a Brocade MLXe-16, MLXe-8 and MLXe-4 (1800W supply) make sure there is a 60 amp circuit breaker, minimum -48Vdc, double pole, on the input lugs to the power supply. The input wiring for connection to the product should be Listed copper wire, 6 AWG, marked VW-1, and rated minimum 90o C.
VORSICHT	Stellen Sie bei der Gleichstromversorgung des Systems bei den Routern Brocade MLXe-4, Brocade MLXe-8 und Brocade MLXe-16 (1800-W-Netzteil) sicher, dass die Anschlussösen des Netzteils mit einem zweipoligen 60-A-Schutzschalter für mindestens -48 V Gleichstrom versehen sind. Die an das Gerät anzuschließenden Eingangsleitungen müssen aus Kupferkabel der Stärke 6 AWG (Bezeichnung VW-1) bestehen und auf eine Temperatur von mindestens 90 °C ausgelegt sein.
MISE EN GARDE	Pour le circuit d'alimentation C.C. du système des routeurs Brocade MLXe-4, Brocade MLXe-8 et Brocade MLXe-16 (alimentation de 1800 W), assurez-vous de la présence d'un disjoncteur bipolaire de 60 ampères, minimum -48 Vcc, sur les cosses d'entrée vers le bloc d'alimentation. Les câbles d'alimentation doivent être en fils de cuivre, 8.37 mm ² , marqués VW-1 et classés 90 °C.
PRECAUCIÓN	Para el circuito de entrada de CC al sistema de los routers Brocade MLXe-4, Brocade MLXe-8, y Brocade MLXe-16 (suministro de 1800 W), asegúrese de que existe un disyuntor bipolar de 60 amperios, de -48 V CC como mínimo, en las terminales de entrada de la fuente de alimentación. El cableado de entrada para la conexión al producto deberá ser de cable de cobre homologado de calibre AWG 6 con clasificación VW-1 para una temperatura mínima de 90 °C.

CAUTION	For the DC input circuit to the system of a Brocade MLXe-32 (3000W supply) make sure there is a 80 amp circuit breaker, minimum -48Vdc, double pole, on the input lugs to the power supply. The input wiring for connection to the product should be Listed copper wire, 4 AWG, marked VW-1, and rated minimum 90o C.
VORSICHT	Bei der Gleichstromeingangsschaltung zum System eines Brocade MLXe-32 (3000W supply), muss sichergestellt werden, dass an den Eingangskabelschuhen zur Stromversorgung ein zweipoliger Schalter mit UL-Zulassung, 80 Ampere und mindestens -48 V Gleichstrom vorhanden ist. Die Eingangsleitung zum Anschluss an das Produkt sollte als Kupferdraht, 4 AWG, angegeben, als VW-1 gekennzeichnet und für mindestens 90 °C bemessen sein.
MISE EN GARDE	Pour le circuit d'alimentation en courant continu du système Brocade MLXe-32 (3000W supply), vérifiez la présence d'un disjoncteur bipolaire homologué de 80 A, minimum -48 Vcc, sur l'entrée de l'alimentation. Les câbles d'alimentation du produit doivent être des fils de cuivre homologués de section 21.14 mm ² , marqués VW-1 et testés à 90 °C.
PRECAUCIÓN	Para el circuito de entrada de CC al sistema de un Brocade MLXe-32 (3000W supply), verifique que existe un disyuntor catalogado por UL de 80 amperios, -48VCC como mínimo, bipolar, en las orejetas de entrada a la fuente de alimentación. El cableado de entrada para la conexión al producto deberá ser de cable de cobre catalogado, 4 AWG, marcado con VW-1, y tener una capacidad nominal mínima para 90 °C.

C Cautions

CAUTION	For the DC input circuit to the system of a Brocade MLX-4, Brocade MLX-8, Brocade MLX-16, and Brocade MLXe-16, Brocade MLXe-8 and Brocade MLXe-4 (1200W supply), make sure there is a 30 amp circuit breaker, minimum -48Vdc, double pole, on the input lugs to the power supply. The input wiring for connection to the product should be copper wire, 8 AWG, marked VW-1, and rated minimum 90o C.
VORSICHT	Stellen Sie bei der Gleichstromversorgung des Systems bei den Routern Brocade MLXe-4, Brocade MLXe-8 und Brocade MLXe-16 (1200-W-Netzteil) sicher, dass die Anschlussösen des Netzteils mit einem zweipoligen 80-A-Schutzschalter für mindestens -48 V Gleichstrom versehen sind. Die an das Gerät anzuschließenden Eingangsleitungen müssen aus Kupferkabel der Stärke 8 AWG (Bezeichnung VW-1) bestehen und auf eine Temperatur von mindestens 90 °C ausgelegt sein.
MISE EN GARDE	Pour le circuit d'alimentation C.C. du système des routeurs Brocade MLXe-4, Brocade MLXe-8 et Brocade MLXe-16 (alimentation de 1200 W), assurez-vous de la présence d'un disjoncteur bipolaire de 80 ampères, minimum -48 Vcc, sur les cosses d'entrée vers le bloc d'alimentation. Les câbles d'alimentation doivent être en fils de cuivre, 8.37 mm ² , marqués VW-1 et classés 90 °C.
PRECAUCIÓN	Para el circuito de entrada de CC al sistema de los routers Brocade MLXe-4, Brocade MLXe-8, y Brocade MLXe-16 (suministro de 1200 W), asegúrese de que existe un disyuntor bipolar de 80 amperios, de -48 V CC como mínimo, en las terminales de entrada de la fuente de alimentación. El cableado de entrada para la conexión al producto deberá ser de cable de cobre homologado de calibre AWG 8 con clasificación VW-1 para una temperatura mínima de 90 °C.

CAUTION	For the DC input circuit to the system of a Brocade Netron XMR 4000, Brocade Netron XMR 8000, and Brocade Netron XMR 16000 (1200W supply), make sure there is a 30 amp circuit breaker, minimum -48Vdc, double pole, on the input lugs to the power supply. The input wiring for connection to the product should be Listed copper wire, 8 AWG, marked VW-1, and rated minimum 90o C.
VORSICHT	Bei der Gleichstromeingangsschaltung zum System eines Brocade Netron XMR 4000, Brocade Netron XMR 8000 und Brocade Netron XMR 16000 (1200W supply), muss sichergestellt werden, dass an den Eingangskabelschuhen zur Stromversorgung ein zweipoliger Schalter mit UL-Zulassung, 30 Ampere und mindestens -48 V Gleichstrom vorhanden ist. Die Eingangsleitung zum Anschluss an das Produkt sollte als Kupferdraht, 8 AWG, angegeben, als VW-1 gekennzeichnet und für mindestens 90 °C bemessen sein.
MISE EN GARDE	Pour le circuit d'alimentation en courant continu du système Brocade Netron XMR 4000, Brocade Netron XMR 8000 ou Brocade Netron XMR 16000 (1200W supply), vérifiez la présence d'un disjoncteur bipolaire homologué de 30 A, minimum -48 Vcc, sur l'entrée de l'alimentation. Les câbles d'alimentation du produit doivent être des fils de cuivre homologués de section 8.37 mm ² , marqués VW-1 et testés à 90 °C.
PRECAUCIÓN	Para el circuito de entrada de CC al sistema de un Brocade Netron XMR 4000, Brocade Netron XMR 8000, y Brocade Netron XMR 16000 (1200W supply), verifique que existe un disyuntor catalogado por UL de 30 amperios, -48VCC como mínimo, bipolar, en las orejetas de entrada a la fuente de alimentación. El cableado de entrada para la conexión al producto deberá ser de cable de cobre catalogado, 8 AWG, marcado con VW-1, y tener una capacidad nominal mínima para 90 °C.

CAUTION	For the DC input circuit to the system of a Brocade MLX-32 (2400W supply), make sure there is a 75 amp circuit breaker, minimum -48Vdc, double pole, on the input lugs to the power supply. The input wiring for connection to the product should be Listed copper wire, 4 AWG, marked VW-1, and rated minimum 90o C.
VORSICHT	Bei der Gleichstromeingangsschaltung zum System eines Brocade MLX-32 (2400W supply), muss sichergestellt werden, dass an den Eingangskabelschuhen der Stromversorgung ein zweipoliger Schalter mit UL-Zulassung, 75 Ampere und mindestens -48 V Gleichstrom vorhanden ist. Die Eingangssignalleitung zum Anschluss an das Produkt sollte als Kupferdraht, 4 AWG, angegeben sein, als VW-1 gekennzeichnet und für mindestens 90 °C bemessen sein.
MISE EN GARDE	Pour le circuit d'alimentation en courant continu du système Brocade MLX -32 (2400W supply), vérifiez la présence d'un disjoncteur bipolaire homologué de 75 A, minimum -48 Vcc, sur l'entrée vers l'alimentation. Les câbles d'alimentation du produit doivent être des fils de cuivre homologués de section 21.14 mm ² , marqués VW-1 et testés à 90 ° C.
PRECAUCIÓN	Para el circuito de entrada de CC al sistema de un Brocade MLX 32 (2400W supply), verifique que existe un disyuntor catalogado por UL de 75 amperios, -48VCC como mínimo, bipolar, en las orejetas de entrada a la fuente de alimentación. El cableado de entrada para la conexión al producto deberá ser de cable de cobre catalogado, 4 AWG, marcado con VW-1, y tener una capacidad nominal mínima para 90 °C.

CAUTION	For the DC input circuit to the system of a Brocade NetIron XMR 32000 (2400W supply), make sure there is a UL-Listed 75 amp circuit breaker, minimum -48Vdc, double pole, on the input lugs to the power supply. The input wiring for connection to the product should be Listed copper wire, 4 AWG, marked VW-1, and rated minimum 90o C.
VORSICHT	Bei der Gleichstromeingangsschaltung zum System eines Brocade NetIron XMR 32000 (2400W supply), muss sichergestellt werden, dass an den Eingangskabelschuhen der Stromversorgung ein zweipoliger Schalter mit UL-Zulassung, 75 Ampere und mindestens -48 V Gleichstrom vorhanden ist. Die Eingangssignalleitung zum Anschluss an das Produkt sollte als Kupferdraht, 4 AWG, angegeben sein, als VW-1 gekennzeichnet und für mindestens 90 °C bemessen sein.
MISE EN GARDE	Pour le circuit d'alimentation en courant continu du système Brocade NetIron XMR 32000 (2400W supply), vérifiez la présence d'un disjoncteur bipolaire homologué de 75 A, minimum -48 Vcc, sur l'entrée vers l'alimentation. Les câbles d'alimentation du produit doivent être des fils de cuivre homologués de section 21.14 mm ² , marqués VW-1 et testés à 90 ° C.
PRECAUCIÓN	Para el circuito de entrada de CC al sistema de un Brocade NetIron XMR 32000 (2400W supply), verifique que existe un disyuntor catalogado por UL de 75 amperios, -48VCC como mínimo, bipolar, en las orejetas de entrada a la fuente de alimentación. El cableado de entrada para la conexión al producto deberá ser de cable de cobre catalogado, 4 AWG, marcado con VW-1, y tener una capacidad nominal mínima para 90 °C.

C Cautions

CAUTION	For the DC input circuit to the system of a Brocade MLXe-32 (3000W supply), make sure there is a UL-Listed 80 amp circuit breaker, minimum -48Vdc, double pole, on the input lugs to the power supply. The input wiring for connection to the product should be Listed copper wire, 4 AWG, marked VW-1, and rated minimum 90o C.
VORSICHT	Bei der Gleichstromeingangsschaltung zum System eines Brocade MLXe-32 (3000W supply) muss sichergestellt werden, dass an den Eingangskabelschuhen der Stromversorgung ein zweipoliger Schalter mit UL-Zulassung, 80 Ampere und mindestens -48 V Gleichstrom vorhanden ist. Die Eingangssignalleitung zum Anschluss an das Produkt sollte als Kupferdraht, 4 AWG, angegeben sein, als VW-1 gekennzeichnet und für mindestens 90 °C bemessen sein.
MISE EN GARDE	Pour le circuit d'alimentation en courant continu du système Brocade MLXe-32 (3000W supply), vérifiez la présence d'un disjoncteur bipolaire homologué de 80 A, minimum -48 Vcc, sur l'entrée vers l'alimentation. Les câbles d'alimentation du produit doivent être des fils de cuivre homologués de section 21.14 mm ² , marqués VW-1 et testés à 90 ° C.
PRECAUCIÓN	Para el circuito de entrada de CC al sistema de un Brocade MLXe-32 (3000W supply), verifique que existe un disyuntor catalogado por UL de 80 amperios, -48VCC como mínimo, bipolar, en las orejetas de entrada a la fuente de alimentación. El cableado de entrada para la conexión al producto deberá ser de cable de cobre catalogado, 4 AWG, marcado con VW-1, y tener una capacidad nominal mínima para 90 °C.

CAUTION	Carefully follow the mechanical guides on each side of the power supply slot and make sure the power supply is properly inserted in the guides. Never insert the power supply upside down.
VORSICHT	Beachten Sie mechanischen Führungen an jeder Seite des Netzteils, das ordnungsgemäß in die Führungen gesteckt werden muss. Das Netzteil darf niemals umgedreht eingesteckt werden.
MISE EN GARDE	Suivez attentivement les repères mécaniques de chaque côté du slot du bloc d'alimentation et assurez-vous que le bloc d'alimentation est bien inséré dans les repères. N'insérez jamais le bloc d'alimentation à l'envers.
PRECAUCIÓN	Siga cuidadosamente las guías mecánicas de cada lado de la ranura del suministro de energía y verifique que el suministro de energía está insertado correctamente en las guías. No inserte nunca el suministro de energía de manera invertida.

CAUTION	Do not add or remove a flash card while a file operation involving the flash card slot is in progress. Doing so can result in corruption of the flash card. If this occurs, you may need to reformat the flash card to make it usable again. Reformatting the card erases all data stored on the card.
VORSICHT	Eine Flash-Karte darf nur dann eingesteckt oder herausgenommen werden, wenn keine Dateifunktion läuft, die der Flash-Karte bedarf. Wenn dies nicht beachtet wird, kann dies zur Korruption der Flash-Karte führen. Die Karte kann dann erst nach Neuformatierung wieder benutzt werden. Bei Neuformatierung gehen alle auf der Karte gespeicherten Daten verloren.
MISE EN GARDE	N'ajoutez pas ou ne supprimez pas une carte mémoire au cours d'une opération de fichier dans laquelle le slot de carte mémoire est impliqué. Vous risquez sinon de corrompre la carte mémoire. Si cela se produit, vous devrez peut-être reformater la carte mémoire pour qu'elle soit à nouveau utilisable. Le reformatage de la carte efface toutes les données qui y sont stockées.
PRECAUCIÓN	No añada ni quite una tarjeta flash mientras una operación de archivo que conlleve el uso de una ranura de tarjeta flash se encuentre en uso. De hacerlo así se podría dar lugar a la corrupción de la tarjeta flash. Si esto ocurriera, podría ser necesario que vuelva a formatear la tarjeta flash para hacer que vuelva sea utilizable. Cuando se formatea la tarjeta se borran todos los datos almacenados en la tarjeta.

CAUTION	Do not install the device in an environment where the operating ambient temperature might exceed 40° C (104° F).
VORSICHT	Das Gerät darf nicht in einer Umgebung mit einer Umgebungsbetriebstemperatur von über 40° C (104° F) installiert werden.
MISE EN GARDE	N'installez pas le dispositif dans un environnement où la température d'exploitation ambiante risque de dépasser 40° C (104° F).
PRECAUCIÓN	No instale el instrumento en un entorno en el que la temperatura ambiente de operación pueda exceder los 40° C (104° F).

CAUTION	Ensure that the device does not overload the power circuits, wiring, and over-current protection. To determine the possibility of overloading the supply circuits, add the ampere (amp) ratings of all devices installed on the same circuit as the device. Compare this total with the rating limit for the circuit. The maximum ampere ratings are usually printed on the devices near the input power connectors.
VORSICHT	Stromkreise, Verdrahtung und Überlastschutz dürfen nicht durch das Gerät überbelastet werden. Addieren Sie die Nennstromleistung (in Ampere) aller Geräte, die am selben Stromkreis wie das Gerät installiert sind. Somit können Sie feststellen, ob die Gefahr einer Überbelastung der Versorgungsstromkreise vorliegt. Vergleichen Sie diese Summe mit der Nennstromgrenze des Stromkreises. Die Höchstnennströme (in Ampere) stehen normalerweise auf der Geräterückseite neben den Eingangsstromanschlüssen.
MISE EN GARDE	Assurez-vous que le dispositif ne risque pas de surcharger les circuits d'alimentation, le câblage et la protection de surintensité. Pour déterminer le risque de surcharge des circuits d'alimentation, additionnez l'intensité nominale (ampères) de tous les dispositifs installés sur le même circuit que le dispositif en question. Comparez alors ce total avec la limite de charge du circuit. L'intensité nominale maximum en ampères est généralement imprimée sur chaque dispositif près des connecteurs d'entrée d'alimentation.
PRECAUCIÓN	Verifique que el instrumento no sobrecargue los circuitos de corriente, el cableado y la protección para sobrecargas. Para determinar la posibilidad de sobrecarga en los circuitos de suministros, añada las capacidades nominales de corriente (amp) de todos los instrumentos instalados en el mismo circuito que el instrumento. Compare esta suma con el límite nominal para el circuito. Las capacidades nominales de corriente máximas están generalmente impresas en los instrumentos, cerca de los conectores de corriente de entrada.

CAUTION	Make sure the air flow around the front, sides, and back of the device is not restricted.
VORSICHT	Stellen Sie sicher, dass an der Vorderseite, den Seiten und an der Rückseite der Luftstrom nicht behindert wird.
MISE EN GARDE	Vérifiez que rien ne restreint la circulation d'air devant, derrière et sur les côtés du dispositif et qu'elle peut se faire librement.
PRECAUCIÓN	Asegúrese de que el flujo de aire en las inmediaciones de las partes anterior, laterales y posterior del instrumento no esté restringido.

C Cautions

CAUTION	Make sure the flash card is empty or does not contain files you want to keep. Formatting a flash card completely erases all files on the card.
VORSICHT	Stellen Sie sicher, dass die Flash-Karte leer ist oder keine Dateien auf ihr gespeichert sind, die Sie behalten möchten. Die Formatierung einer Flash-Karte löscht alle Dateien auf der Karte.
MISE EN GARDE	Vérifiez que la carte mémoire est vide ou ne contient pas de fichiers que vous voulez conserver. Le reformatage de la carte mémoire efface tous les fichiers qui s'y trouvent.
PRECAUCIÓN	Verifique que la tarjeta flash esté vacía o que no contenga archivos que desee conservar. Al formatear una tarjeta flash todos los archivos de ésta se borran.

CAUTION	Never leave tools inside the chassis.
VORSICHT	Lassen Sie keine Werkzeuge im Chassis zurück.
MISE EN GARDE	Ne laissez jamais d'outils à l'intérieur du châssis.
PRECAUCIÓN	No deje nunca herramientas en el interior del chasis.

CAUTION	Once you start the formatting process, you cannot stop it. Even if you enter CTRL-C to stop the CLI output and a new prompt appears, the formatting continues. Make sure you want to format the card before you enter the command.
VORSICHT	Wenn Sie mit dem Formattieren beginnen, können Sie diesen Prozess nicht anhalten. Selbst wenn zum Anhalten der CLI-Ausgabe Strg-C drücken und eine neue Aufforderung gezeigt wird, wird mit dem Formattieren fortgefahren. Stellen Sie sicher, dass Sie die Karte formattieren wollen, bevor Sie den Befehl eingeben.
MISE EN GARDE	Une fois le processus de formatage commencé, vous ne pouvez pas l'interrompre. Même si vous appuyez sur CTRL-C pour arrêter la sortie CLI et si une nouvelle invite apparaît, le formatage continue. Soyez bien sûr de vouloir formater la carte avant d'entrer la commande.
PRECAUCIÓN	Una vez que empieza con el proceso de formateado, no se puede detener. Incluso si pulsa CTRL-C para detener la salida de CLI y aparece un nuevo indicador, el formateado continuará. Está seguro que desea formatear la tarjeta antes de introducir el comando.

CAUTION	Use the erase startup-config command only for new systems. If you enter this command on a system you have already configured, the command erases the configuration. If you accidentally do erase the configuration on a configured system, enter the write memory command to save the running configuration to the startup-config file.
VORSICHT	Verwenden Sie den Befehl "Erase startup-config" (Löschen Startup-Konfig) nur für neue Systeme. Wenn Sie diesen Befehl in ein bereits konfiguriertes System eingeben, löscht der Befehl die Konfiguration. Falls Sie aus Versehen die Konfiguration eines bereits konfigurierten Systems löschen, geben Sie den Befehl "Write Memory" (Speicher schreiben) ein, um die laufende Konfiguration in der Startup-Konfig-Datei zu speichern.
MISE EN GARDE	N'utilisez la commande erase startup-config que pour les nouveaux systèmes. Si vous entrez cette commande sur un système que vous avez déjà configuré, elle efface la configuration. Si vous effacez la configuration par accident sur un système configuré, entrez la commande write memory pour enregistrer la configuration actuelle dans le fichier startup-config.
PRECAUCIÓN	Use el comando erase startup-config (borrar configuración de inicio) para sistemas nuevos solamente. Si usted introduce este comando en un sistema que ya ha configurado, el comando borrará la configuración. Si usted borra accidentalmente la configuración en un sistema ya configurado, introduzca el comando write memory (escribir memoria) para guardar la configuración en ejecución en el archivo startup-config.

CAUTION	Removal of Brocade NetIron XMR 32000 rear fan modules allows access to bus bars and backplane. Avoid contact with these parts. There are hazardous energy levels at these locations.
VORSICHT	Durch die Entfernung der rückwärtigen Brocade NetIron XMR 32000 Ventilatormodule wird der Zugang zu den Sammelschienen und der Rückwandplatine ermöglicht. Kontakt mit diesen Teilen vermeiden. An diesen Stellen liegen gefährliche Stromstärken an.
MISE EN GARDE	La dépose des modules de ventilation en face arrière du Brocade NetIron XMR 32000 permet d'accéder à la distribution électrique et au fond de panier. Éviter tout contact avec ces éléments, car les tensions électriques dans cette zone sont très élevées.
PRECAUCIÓN	El desmontaje de los módulos del ventilador trasero del sistema Brocade NetIron XMR 32000 permite el acceso a las barras del bus y a la placa posterior. Evite el contacto con estas piezas. Hay niveles peligrosos de energía en tales lugares.

CAUTION	To avoid overheating of the Brocade NetIron XMR 16000 and Brocade NetIron XMR 32000 chassis, remove only one fan assembly at a time.
VORSICHT	Es darf nur ein Ventilatorblech zur Zeit entfernt werden, um ein Überhitzen des Brocade NetIron XMR 16000 und Brocade NetIron XMR 32000 chassis Gehäuses zu vermeiden. Es dürfen nicht beide Ventilatorbleche auf einmal entfernt werden.
MISE EN GARDE	Pour éviter la surchauffe du châssis des Brocade NetIron XMR 16000 et Brocade NetIron XMR 32000, n'enlever qu'un seul boîtier de ventilateur à la fois. Ne pas enlever les deux boîtiers du châssis en même temps.
PRECAUCIÓN	Para evitar el sobrecalentamiento del chasis Brocade NetIron XMR 16000 y Brocade NetIron XMR 32000, desmonte solamente una bandeja de ventilador a la vez. No retire las dos bandejas de ventilador del chasis a la vez.

CAUTION	Use a separate branch circuit for each AC power cord, which provides redundancy in case one of the circuits fails.
VORSICHT	Es empfiehlt sich die Installation eines separaten Stromkreisweiges für jede Wechselstrom-Elektroschnur als Redundanz im Fall des Ausfalls eines Stromkreises.
MISE EN GARDE	Utilisez un circuit de dérivation différent pour chaque cordon d'alimentation C.A. Ainsi, il y aura un circuit redondant en cas de panne d'un des circuits.
PRECAUCIÓN	Use un circuito derivado separado para cada cordón de alimentación de CA, con lo que se proporcionará redundancia en caso de que uno de los circuitos falle.

CAUTION	If you do not install a module in a slot, you must keep the slot panel in place. If you run the chassis with an uncovered slot, the system may overheat.
VORSICHT	Falls kein Modul im Steckplatz installiert wird, muss die Steckplatztafel angebracht werden. Wenn ein Steckplatz nicht abgedeckt wird, läuft das System heiß.
MISE EN GARDE	Si vous n'installez pas de module dans un slot, vous devez laisser le panneau du slot en place. Si vous faites fonctionner le châssis avec un slot découvert, le système surchauffera.
PRECAUCIÓN	Si no instala un módulo en la ranura, deberá mantener el panel de ranuras en su lugar. Si pone en funcionamiento el chasis con una ranura descubierta, el sistema sufrirá sobrecalentamiento.

C Cautions

CAUTION	If you do not install a module in a slot, you must keep the slot blank in place. If you run the chassis with an uncovered slot, the system may overheat. Tighten the screws that secure the slot blanks so that they remain in place when removing adjacent panels or modules.
VORSICHT	Wenn in einem Steckplatz kein Modul installiert wird, muss die Steckplatz-Leerblende immer angebracht sein. Wird das Chassis mit einem leeren Steckplatz ohne Leerblende betrieben, kann dies zu Überhitzung führen. Die Befestigungsschrauben der Leerblenden festziehen, damit sie sich beim Herausnehmen benachbarter Blenden oder Module nicht lösen können.
MISE EN GARDE	Si aucun module n'est installé dans un emplacement, laisser le cache de cet emplacement en place. Le système peut chauffer si le châssis est mis en service avec un emplacement ouvert. Serrer les vis de fixation des caches des emplacements vides de façon à les laisser en place lors de la dépose des panneaux ou des modules adjacents.
PRECAUCIÓN	En caso de no instalar un módulo en una ranura, deberá taparla con la cubierta al efecto. Si llegara a poner en funcionamiento el chasis con una ranura descubierta el sistema podría sobrecalentarse. Apriete los tornillos que fijan las cubiertas de las ranuras para impedir que se muevan al desmontar los paneles o módulos adyacentes.

CAUTION:	All devices with AC power sources are intended for installation in restricted access areas only. A restricted access area is a location where access can be gained only by service personnel through the use of a special tool, lock and key, or other means of security.
VORSICHT	Alle Geräte mit Wechselstromquellen sind nur zur Installation in Sperrbereichen bestimmt. Ein Sperrbereich ist ein Ort, zu dem nur Wartungspersonal mit einem Spezialwerkzeug, Schloss und Schlüssel oder einer anderen Schutzvorrichtung Zugang hat.
MISE EN GARDE	Tous les équipements dotés de sources d'alimentation électrique secteur sont destinés à être installés uniquement dans des zones à accès réglementé. Une zone à accès réglementé est une zone dont l'accès n'est possible qu'au personnel de service utilisant un verrou, une clé ou un outil spécial, ou d'autres moyens de sécurité.
PRECAUCIÓN	Todos aquellos dispositivos con fuentes de alimentación de CA están diseñados para su instalación en zonas de acceso restringido solamente. Una zona de acceso restringido es un lugar al que sólo puede acceder personal de mantenimiento haciendo uso de una herramienta especial, una llave y un candado, o algún otro medio de seguridad.

CAUTION	For a Brocade NetIron XMR 32000 AC system, use a ground wire of at least 6 American Wire Gauge (AWG). The ground wire should have an agency-approved crimped connector (provided with the chassis) attached to one end, with the other end attached to building ground. The connector must be crimped with the proper tool, allowing it to be connected to both ground screws on the enclosure.
VORSICHT	Für ein Wechselstromsystem Brocade NetIron XMR 32000 ist ein Erdleiter von mindestens 6 AWG (amerikanische Norm für Drahtquerschnitte) zu verwenden. An einem Ende des Erdleiters sollte ein geprüfter gecrimpter Anschluss (mit Chassis bereitgestellt) angebracht sein. Das andere Ende sollte an der Gebäudeerdung angeschlossen werden. Der Anschluss muss mit dem richtigen Werkzeug gecrimpt werden, so dass er an beiden Erdungsschrauben am Gehäuse angeschlossen werden kann.
MISE EN GARDE	Pour un système à alimentation secteur Brocade NetIron XMR 32000, utiliser un câble de mise à la terre de calibre 13.29 mm ² minimum. Ce fil de terre doit être équipé d'un côté d'un connecteur à sertir agréé (fourni avec le châssis), et l'autre extrémité doit être reliée à la terre du bâtiment. Ce connecteur doit être serti à l'aide de l'outil approprié afin d'être raccordé aux deux vis de mise à la terre du boîtier.
PRECAUCIÓN	Para un sistema de CA Brocade NetIron XMR 32000, utilice un conductor de tierra de al menos 6 CAE (Calibre de Alambre Estadounidense, American Wire Gauge o AWG en sus siglas en inglés). El conductor de tierra debe tener un conector rizado homologado (suministrado con el chasis) acoplado a un extremo, y el otro extremo debe estar conectado a la tierra del edificio. El conector debe rizarse con la herramienta apropiada, de manera que se conecte a los dos tornillos de tierra del recinto.

CAUTION	Be sure not to exceed the minimum recommended bend radius for the cables: 2" for MRJ-21 cables, and 1.5" for Category 5 (RJ45) and fiber-optic cables.
VORSICHT	Der empfohlene Mindestbiegeradius für die Kabel darf nicht überschritten werden: 2 Zoll (5,08 cm) bei MRJ-21-Kabeln und 1,5 Zoll (3,81 cm) bei Kabeln der Kategorie 5 (RJ45) und Glasfaserkabeln.
MISE EN GARDE	Respecter le rayon de courbure minimal recommandé pour les câbles (5,08 cm pour les câbles MRJ-21 et 3,81 cm pour les câbles Ethernet de catégorie 5 (RJ45) et les fibres optiques).
PRECAUCIÓN	Asegúrese de no exceder el radio de curvatura recomendado para los cables: 2" para los cables MRJ-21 y 1,5" para cables de Categoría 5 (RJ45) y de fibra óptica.

CAUTION	If hot removing or inserting a module, please allow a minimum of two seconds after a module (or power supply or fan tray) has been removed before inserting a module in the same slot.
VORSICHT:	Beim Herausnehmen oder Einschieben eines Moduls bei laufendem Betrieb sollte nach dem Herausnehmen des Moduls (oder einer Stromversorgung oder eines Lüftereinsatzes) mindestens zwei Minuten gewartet werden, bevor ein Modul in denselben Steckplatz eingeschoben wird.
MISE EN GARDE	En cas de dépose et d'insertion à chaud d'un module, attendre au moins 2 secondes entre la dépose du module d'origine (y compris les modules de ventilation et d'alimentation) et l'insertion du nouveau module dans le même emplacement.
PRECAUCIÓN	En caso de desmontar o insertar un módulo mientras el chasis está en funcionamiento, espere un mínimo de dos segundos después de haber desmontado el módulo (o la fuente de alimentación o la bandeja del ventilador) antes de introducir un módulo en la misma ranura.

C Cautions

CAUTION	All devices with DC power supplies are intended for installation in restricted access areas only. A restricted access area is where access can be gained only by service personnel through the use of a special tool, lock and key, or other means of security, and is controlled by the authority responsible for the location.
VORSICHT	Geräte mit Gleichstromnetzteil sind nur zur Installation in Bereichen mit Zugangsbeschränkung bestimmt. Eine Zugangsbeschränkung bedeutet, dass das Servicepersonal nur mit besonderen Hilfsmitteln, Verriegelungen, Schlüsseln oder anderen Sicherheitseinrichtungen Zugang erlangen kann und von der für den Standort verantwortlichen Stelle überwacht wird.
MISE EN GARDE	Tous les dispositifs avec alimentation CC doivent être installés dans des zones à accès réglementé uniquement. Une zone à accès réglementé est réservée au personnel de maintenance, qui peut y accéder uniquement à l'aide d'un verrou, d'une clé ou d'un outil spécifique, ou via d'autres procédures de sécurité, et qui est contrôlée par les autorités responsables du site.
PRECAUCIÓN	Todos los dispositivos con fuentes de alimentación de CC están previstos solo para su instalación en áreas de acceso restringido. Por área de acceso restringido se entiende las zonas a las que solo puede tener acceso personal de mantenimiento mediante el uso de una herramienta especial, una cerradura con llave u otro medio de seguridad y están controladas por la autoridad responsable del lugar.

CAUTION	For the DC input circuit (DC power supply part number RPS9-DC), make sure there is a 20 amp circuit breaker, minimum 48Vdc, double pole, on the input to the power supply. The input wiring for connection to the product should be copper wire, 12 AWG, marked VW-1, and rated minimum 90 C.
VORSICHT	Stellen Sie bei einer Gleichstromversorgung (Gleichstromnetzteil, Teilenummer RPS9-DC) sicher, dass der Eingang des Netzteils mit einem zweipoligen 20-A-Schutzschalter für mindestens -48 V Gleichstrom versehen ist. Die Eingangsleitungen für das Gerät müssen aus Kupferkabel der Stärke 12 AWG (Bezeichnung VW-1) bestehen, das für mindestens 90 °C geeignet ist.
MISE EN GARDE	Pour le circuit d'alimentation CC (numéro de pièce RPS9-DC), assurez-vous de la présence d'un disjoncteur de 20 ampères (minimum 48 Vcc, bipolaire) sur l'entrée menant au bloc d'alimentation. Les câbles d'alimentation doivent être en fils de cuivre, de 3.31 mm ² , marqués VW-1 et classés 90 ° C minimum.
PRECAUCIÓN	Para el circuito de entrada de CC (número de pieza de fuente de alimentación de CC RPS9-DC), asegúrese de que haya un disyuntor de 20 amp, como mínimo de 48 VCC y bipolar en la entrada de la fuente de alimentación. El cable de la conexión al producto debe ser de cobre, de calibre 12 AWG, marcado como VW-1 y como mínimo de 90 C.

CAUTION	For a DC system (DC power supply part number RPS9-DC), use a grounding wire of at least 6 American Wire Gauge (AWG). The 6 AWG wire should be attached to an agency-approved crimp connector, crimped with the proper tool.
VORSICHT	Für Geräte mit Gleichstromversorgung (Gleichstromnetzteil, Teilenummer RPS9-DC) muss zur Erdung ein Kabel der Stärke 6 AWG (American Wire Gauge) verwendet werden. Das 6-AWG-Kabel muss mithilfe eines geeigneten Crimp-Werkzeugs mit einem normgerechten Crimp-Verbinder verbunden werden.
MISE EN GARDE	Pour un système CC (numéro de pièce RPS9-DC), utilisez un fil de mise à la terre d'au moins 13.29 mm ² . Le fil de 13.29 mm ² doit être relié à une cosse homologuée, sertie avec l'outil approprié.
PRECAUCIÓN	Para un sistema de CC (número de pieza de fuente de alimentación CC RPS9-DC), utilice un cable de conexión a tierra con un calibre mínimo de 6 según el estándar American Wire Gauge (AWG). El cable de 6 AWG se debe conectar a un conector por compresión aprobado por la agencia, comprimido con la herramienta adecuada.

Dangers

A danger calls your attention to a possible hazard that can cause injury or death. The following are the dangers used in this manual.

"Gefahr" weist auf eine mögliche Gefährdung hin, die zu Verletzungen oder Tod führen können. Sie finden die folgenden Warnhinweise in diesem Handbuch.

Un danger attire votre attention sur un risque possible de blessure ou de décès. Ci-dessous, vous trouverez les dangers utilisés dans ce manuel.

Una advertencia le llama la atención sobre cualquier posible peligro que pueda ocasionar daños personales o la muerte. A continuación se dan las advertencias utilizadas en este manual.

DANGER	Laser Radiation. Do Not View Directly with Optical Instruments. Class 1M Laser Products.
GEFAHR	Laserstrahlung! Schauen Sie nicht direkt mit optischen Instrumenten in den Laserstrahl herein. Klasse 1M Laserprodukte.
DANGER	Rayonnement de laser. Ne regardez pas directement avec les instruments optiques. Produits de laser de la classe 1M.
PELIGRO	Radiacion de Laser. No vea directamente con Instrumentos Opticos. Clase 1M de Productos de Laser.

DANGER	All fiber optic interfaces use Class 1 lasers.
GEFAHR	Alle Glasfaser-Schnittstellen verwenden Laser der Klasse 1.
DANGER	Toutes les interfaces en fibres optiques utilisent des lasers de classe 1.
PELIGRO	Todas las interfaces de fibra óptica utilizan láser de clase 1.

DANGER	Installation and removal of the unit must be carried out by qualified personnel only.
GEFAHR	Die Installation und Entfernung der Einheit dürfen nur von qualifiziertem Personal ausgeführt werden.
DANGER	L'installation et la dépose de l'unité doivent être confiées uniquement à du personnel qualifié.
PELIGRO	La instalación y desinstalación de la unidad debe llevarse a cabo solamente por personal cualificado.

DANGER	Before beginning the installation, refer to the precautions in the Power precautions section.
GEFAHR	Vor der Installation siehe Vorsichtsmaßnahmen unter "Power Precautions" (Vorsichtsmaßnahmen in Bezug auf elektrische Ablagen).
DANGER	Avant de commencer l'installation, consultez les précautions décrites dans "Power Precautions" (Précautions quant à l'alimentation).
PELIGRO	Antes de comenzar la instalación, consulte las precauciones en la sección "Power Precautions" (Precauciones sobre corriente).

C Dangers

DANGER	Disconnect the power cord from all power sources to completely remove power from the device.
GEFAHR	Ziehen Sie das Stromkabel aus allen Stromquellen, um sicherzustellen, dass dem Gerät kein Strom zugeführt wird.
DANGER	Débranchez le cordon d'alimentation de toutes les sources d'alimentation pour couper complètement l'alimentation du dispositif.
PELIGRO	Para desconectar completamente la corriente del instrumento, desconecte el cordón de corriente de todas las fuentes de corriente.

DANGER	If the installation requires a different power cord than the one supplied with the device, make sure you use a power cord displaying the mark of the safety agency that defines the regulations for power cords in your country. The mark is your assurance that the power cord can be used safely with the device.
GEFAHR	Falls für die Installation ein anderes Stromkabel erforderlich ist (wenn das mit dem Gerät gelieferte Kabel nicht passt), müssen Sie sicherstellen, dass Sie ein Stromkabel mit dem Siegel einer Sicherheitsbehörde verwenden, die für die Zertifizierung von Stromkabeln in Ihrem Land zuständig ist. Das Siegel ist Ihre Garantie, dass das Stromkabel sicher mit Ihrem Gerät verwendet werden kann.
DANGER	Si l'installation nécessite un cordon d'alimentation autre que celui fourni avec le dispositif, assurez-vous d'utiliser un cordon d'alimentation portant la marque de l'organisation responsable de la sécurité qui définit les normes et réglementations pour les cordons d'alimentation dans votre pays. Cette marque vous assure que vous pouvez utiliser le cordon d'alimentation avec le dispositif en toute sécurité.
PELIGRO	Si la instalación requiere un cordón de corriente distinto al que se ha suministrado con el instrumento, verifique que usa un cordón de corriente que venga con la marca de la agencia de seguridad que defina las regulaciones para cordones de corriente en su país. Esta marca será su garantía de que el cordón de corriente puede ser utilizado con seguridad con el instrumento.

DANGER	Make sure that the power source circuits are properly grounded, then use the power cord supplied with the device to connect it to the power source.
GEFAHR	Stellen Sie sicher, dass die Stromkreise ordnungsgemäß geerdet sind. Benutzen Sie dann das mit dem Gerät gelieferte Stromkabel, um es an die Stromquelle anzuschließen.
DANGER	Vérifiez que les circuits de sources d'alimentation sont bien mis à la terre, puis utilisez le cordon d'alimentation fourni avec le dispositif pour le connecter à la source d'alimentation.
PELIGRO	Verifique que circuitos de la fuente de corriente están conectados a tierra correctamente; luego use el cordón de potencia suministrado con el instrumento para conectarlo a la fuente de corriente.

DANGER	Make sure the rack or cabinet housing the device is adequately secured to prevent it from becoming unstable or falling over.
GEFAHR	Stellen Sie sicher, dass das Gestell oder der Schrank für die Unterbringung des Geräts auf angemessene Weise gesichert ist, so dass das Gestell oder der Schrank nicht wackeln oder umfallen kann.
DANGER	Vérifiez que le bâti ou le support abritant le dispositif est bien fixé afin qu'il ne devienne pas instable ou qu'il ne risque pas de tomber.
PELIGRO	Verifique que el bastidor o armario que alberga el instrumento está asegurado correctamente para evitar que pueda hacerse inestable o que caiga.

DANGER	Mount the devices you install in a rack or cabinet as low as possible. Place the heaviest device at the bottom and progressively place lighter devices above.
GEFAHR	Montieren Sie die Geräte im Gestell oder Schrank so tief wie möglich. Platzieren Sie das schwerste Gerät ganz unten, während leichtere Geräte je nach Gewicht (je schwerer desto tiefer) darüber untergebracht werden.
DANGER	Montez les dispositifs que vous installez dans un bâti ou support aussi bas que possible. Placez le dispositif le plus lourd en bas et le plus léger en haut, en plaçant tous les dispositifs progressivement de bas en haut du plus lourd au plus léger.
PELIGRO	Monte los instrumentos que instale en un bastidor o armario lo más bajos posible. Ponga el instrumento más pesado en la parte inferior y los instrumentos progresivamente más livianos más arriba.

DANGER	For safety reasons, the ESD wrist strap should contain a series 1 megohm resistor.
GEFAHR	Aus Sicherheitsgründen sollte ein EGB-Armband zum Schutz von elektronischen gefährdeten Bauelementen mit einem 1 Megaohm-Reihenwiderstand ausgestattet sein.
DANGER	Pour des raisons de sécurité, la dragonne ESD doit contenir une résistance de série 1 méga ohm.
PELIGRO	Por razones de seguridad, la correa de muñeca ESD deberá contener un resistor en serie de 1 mega ohmio.

DANGER	The power supplies are hot swappable, which means they can be removed and replaced while the chassis is powered on and running. However, Brocade recommends that you disconnect a power supply from its power source before removing and replacing the supply. The Brocade NetIron XMR 4000, 8000, or 16000 chassis can be running while a power supply is being removed and replaced, but the power supply itself should not be connected to a power source. Otherwise, you could be injured or the power supply or other parts of the device could be damaged.
GEFAHR	Die Wechselstrom-Netzteile können während des Betriebs des Gehäuse abgenommen und ausgetauscht werden. Allerdings empfiehlt Brocade, den Stecker des Wechselstrom-Netzteils aus der Steckdose zu ziehen, bevor das Netzteil abgenommen und ausgetauscht wird. Ein Netzteil kann während des Betriebs des Brocade NetIron XMR 4000, 8000, or 16000 abgenommen und ausgetauscht werden. Allerdings sollte das Netzteil nicht an eine Stromquelle angeschlossen sein. Bei Nichtbeachtung könnte dies zu Verletzungen des Bedieners oder Beschädigung des Wechselstrom-Netzteils oder anderer Geräteteile führen.
DANGER	Les alimentations électriques sont échangeables à chaud. Elles peuvent être déposées et remplacées pendant que le châssis est allumé et en cours de fonctionnement. Cependant, Brocade recommande de débrancher le bloc d'alimentation C.A. du secteur avant d'enlever ou de remplacer le bloc d'alimentation. Le châssis Brocade NetIron XMR 4000, 8000 ou 16000 peut fonctionner pendant le retrait et le remplacement d'une alimentation électrique, mais il est important que celle-ci ne soit pas raccordée à la source secteur. Faute de déconnecter l'alimentation électrique du secteur, le personnel risque d'être blessé ou d'endommager l'alimentation électrique ou d'autres composants.
PELIGRO	Los suministros de corriente alterna pueden desmontarse y reemplazarse cuando el chasis está activado y en funcionamiento. No obstante, Brocade recomienda que se desconecte el suministro de corriente alterna del tomacorriente antes de desmontar y reemplazar el suministro. El chasis Brocade NetIron XMR 4000, 8000, ó 16000 puede estar en funcionamiento cuando un suministro de corriente esté siendo desmontado y reemplazado, pero el suministro de corriente en sí no deberá estar conectado a la corriente. De lo contrario, podría sufrir daños personales o el suministro de corriente alterna u otras partes del dispositivo podrían sufrir desperfectos.

C Dangers

DANGER	All fiber-optic interfaces use Class 1 Lasers.
GEFAHR	Alle Glasfaser-Schnittstellen verwenden Laser der Klasse 1.
DANGER	Toutes les interfaces en fibres optiques utilisent des lasers de classe 1.
ADVERTENCIA	Todas las interfaces de fibra óptica utilizan láser de clase 1.

DANGER	The front panel of an AC power supply includes a handle that locks the power supply in the chassis. This handle is a locking mechanism only and should not be used to lift and carry the power supply. You may sustain physical injury or harm if you attempt to lift and carry a power supply using the locking handle.
GEFAHR	Die Vorderabdeckung eines Wechselstrom-Netzteils verfügt über einen Griff, mit dem das Netzteil im Gehäuse verriegelt werden kann. Dieser Griff dient nur der Verriegelung. Mit ihm sollte das Netzteil weder angehoben noch getragen werden. Anheben und Tragen eines Netzteils mit dem Verriegelungsgriff kann zu Verletzungen führen.
DANGER	Le panneau avant d'un bloc d'alimentation C.A. comprend une poignée qui permet de verrouiller le bloc d'alimentation dans le châssis. Cette poignée est un mécanisme de verrouillage uniquement, elle ne doit pas être utilisée pour soulever et transporter le châssis. Vous risquez d'être blessé si vous essayez de soulever et de transporter un bloc d'alimentation avec la poignée de verrouillage.
PELIGRO	El panel delantero de un suministro de corriente alterna incluye un mango que bloquea el suministro de corriente al chasis. El mango es un mecanismo de bloqueo solamente y no deberá usarse para alzar ni transportar el suministro de corriente. De hacerlo así, podría sufrir daños personales.

DANGER	A fully-populated Brocade NetIron XMR 4000, 8000, or 16000 chassis is heavy. TWO OR MORE PEOPLE ARE REQUIRED WHEN LIFTING, HANDLING, OR MOUNTING THESE DEVICES.
GEFAHR	Ein voll bestücktes Brocade NetIron XMR 4000, 8000, oder 16000 Gehäuse ist schwer. ZUM ANHEBEN, HANDHABEN ODER MONTIEREN DIESER GERÄTE SIND MINDESTENS ZWEI PERSONEN ERFORDERLICH.
DANGER	Un châssis Brocade NetIron XMR 4000, 8000 ou 16000 entièrement équipé est extrêmement lourd. POUR SOULEVER, MANIPULER OU MONTER CES ÉQUIPEMENTS, DEUX PERSONNES AU MINIMUM SONT NÉCESSAIRES.
PELIGRO	Un chasis Brocade NetIron XMR 4000, 8000, ó 16000 muy concurrido es muy pesado. SE REQUIEREN DOS O MÁS PERSONAS CUANDO SE VAYA A ALZAR, MANEJAR O MONTAR ESTE DISPOSITIVO.

DANGER	A fully-populated Brocade MLX Series-4, -8, or -16 chassis is heavy. TWO OR MORE PEOPLE ARE REQUIRED WHEN LIFTING, HANDLING, OR MOUNTING THESE DEVICES.
GEFAHR	Ein voll bestücktes Brocade MLX Series-4, -8, oder -16 Gehäuse ist schwer. ZUM ANHEBEN, HANDHABEN ODER MONTIEREN DIESER GERÄTE SIND MINDESTENS ZWEI PERSONEN ERFORDERLICH.
DANGER	Un châssis Brocade MLX Series-4, -8, ou -16 entièrement équipé est extrêmement lourd. POUR SOULEVER, MANIPULER OU MONTER CES ÉQUIPEMENTS, DEUX PERSONNES AU MINIMUM SONT NÉCESSAIRES.
PELIGRO	Un chasis Brocade MLX Series-4, -8, ó -16 muy concurrido es muy pesado. SE REQUIEREN DOS O MÁS PERSONAS CUANDO SE VAYA A ALZAR, MANEJAR O MONTAR ESTE DISPOSITIVO.

DANGER	A fully-populated Brocade MLX Series-16 chassis is heavy. TWO OR MORE PEOPLE ARE REQUIRED WHEN LIFTING, HANDLING, OR MOUNTING THESE DEVICES.
GEFAHR	Ein voll bestücktes Brocade MLX Series-16 Gehäuse ist schwer. ZUM ANHEBEN, HANDHABEN ODER MONTIEREN DIESER GERÄTE SIND MINDESTENS ZWEI PERSONEN ERFORDERLICH.
DANGER	Un châssis Brocade MLX Series-16 entièrement équipé est extrêmement lourd. POUR SOULEVER, MANIPULER OU MONTER CES ÉQUIPEMENTS, DEUX PERSONNES AU MINIMUM SONT NÉCESSAIRES.
PELIGRO	Un chasis Brocade MLX Series-16 muy concurrido es muy pesado. SE REQUIEREN DOS O MÁS PERSONAS CUANDO SE VAYA A ALZAR, MANEJAR O MONTAR ESTE DISPOSITIVO.

DANGER	The Brocade NetIron XMR 32000 fan assembly is heavy and will be off-balance as you remove it. Use both hands on the handle.
GEFAHR	Die Brocade NetIron XMR 32000-Ventilatoreinheit ist schwer und kommt aus dem Gleichgewicht, wenn sie entfernt wird. Den Griff mit beiden Händen anfassen.
DANGER	Le module de ventilation du Brocade NetIron XMR 32000 est lourd et peut déséquilibrer lors de la dépose. Tenir la poignée à l'aide des deux mains.
PELIGRO	La unidad del ventilador del sistema Brocade NetIron XMR 32000 es pesada y quedará desequilibrada al desmontarla. Agarre el asa con las dos manos.

DANGER	Make sure to choose the appropriate circuit device depending on the number of AC power supplies installed in the chassis.
GEFAHR	Je nach Anzahl der Wechselstrom-Netzteile im Gehäuse muss das passende Stromgerät ausgewählt werden.
DANGER	Assurez-vous de choisir le dispositif de circuit approprié selon le nombre de blocs d'alimentation C.A. installés dans le châssis.
PELIGRO	Asegúrese de que elige el dispositivo de circuitos apropiado dependiendo del número de suministros de corriente alterna instalados en el chasis.

DANGER	Be careful not to accidentally insert your fingers into the fan tray while removing it from the chassis. The fan may still be spinning at a high speed.
GEFAHR	Die Finger dürfen nicht versehentlich in das Ventilatorblech gesteckt werden, wenn dieses vom Gehäuse abgenommen wird. Der Ventilator kann sich unter Umständen noch mit hoher Geschwindigkeit drehen.
DANGER	Faites attention de ne pas accidentellement insérer vos doigts dans le boîtier du ventilateur lorsque vous l'enlevez du châssis. Il est possible que le ventilateur tourne encore à grande vitesse.
PELIGRO	Procure no insertar los dedos accidentalmente en la bandeja del ventilador cuando esté desmontando el chasis. El ventilador podría estar girando a gran velocidad.

C Dangers

DANGER	To prevent damage to the chassis and components, never attempt to lift the chassis using the fan or power supply handles. These handles were not designed to support the weight of the chassis.
GEFAHR	Alle Geräte mit Wechselstromquellen sind nur zur Installation in Sperrbereichen bestimmt. Ein Sperrbereich ist ein Ort, zu dem nur Wartungspersonal mit einem Spezialwerkzeug, Schloss und Schlüssel oder einer anderen Schutzvorrichtung Zugang hat.
DANGER	Pour éviter d'endommager le châssis et les composants, ne jamais tenter de soulever le châssis par les poignées du ventilateur ou de l'alimentation. Ces poignées n'ont pas été conçues pour supporter le poids du châssis.
PELIGRO	Para prevenir daños al chasis y a los componentes, nunca intente levantar el chasis usando las asas de la fuente de alimentación o del ventilador. Tales asas no han sido diseñadas para soportar el peso del chasis.

DANGER	Do not attempt to lift a Brocade NetIron XMR 32000 chassis. It is extremely heavy. REMOVE THE POWER SUPPLIES AND INTERFACE MODULES FIRST (management, switch fabric, and all line cards). Use a mechanical lifting device to lift the chassis. Four or more people are required to position the unpopulated chassis into the rack.
GEFAHR	Nicht versuchen, ein Brocade NetIron XMR 32000 Chassis anzuheben. Es ist sehr schwer. ZUERST DIE STROMVERSORGUNGEN UND SCHNITTSTELLENMODULE ENTFERNEN (Management, Switch-Fabric und alle Line-Cards). Das Chassis mit Hilfe einer mechanischen Hebevorrichtung anheben. Mindestens vier Personen sind erforderlich, um das unbeladene Chassis im Rack zu positionieren.
DANGER	Ne jamais tenter de soulever un châssis Brocade NetIron XMR 32000 car il est alors extrêmement lourd. DÉPOSER AU PRÉALABLE LES ALIMENTATIONS ÉLECTRIQUES ET LES MODULES D'INTERFACE (supervision, matrice de commutation et cartes de lignes). Pour soulever le châssis, utiliser un appareil élévateur. Quatre personnes au moins sont nécessaires pour positionner dans le rack le châssis vidé de ses éléments.
PELIGRO	No trate de levantar un chasis Brocade NetIron XMR 32000. Es extremadamente pesado. QUITE PRIMERO LOS MÓDULOS DE INTERFAZ Y DE ALIMENTACIÓN (administración, matriz de conmutación, y todas las tarjetas de línea). Utilice un elevador mecánico para levantar el chasis. Hacen falta cuatro personas o más para colocar el chasis no poblado en el interior del armazón.

DANGER	Do not attempt to lift a Brocade MLX Series-32 chassis. It is extremely heavy. REMOVE THE POWER SUPPLIES AND INTERFACE MODULES FIRST (management, switch fabric, and all line cards). Use a mechanical lifting device to lift the chassis. Four or more people are required to position the unpopulated chassis into the rack.
GEFAHR	Nicht versuchen, ein Brocade MLX Series-32 Chassis anzuheben. Es ist sehr schwer. ZUERST DIE STROMVERSORGUNGEN UND SCHNITTSTELLENMODULE ENTFERNEN (Management, Switch-Fabric und alle Line-Cards). Das Chassis mit Hilfe einer mechanischen Hebevorrichtung anheben. Mindestens vier Personen sind erforderlich, um das unbeladene Chassis im Rack zu positionieren.
DANGER	Ne jamais tenter de soulever un châssis Brocade MLX Series-32 car il est alors extrêmement lourd. DÉPOSER AU PRÉALABLE LES ALIMENTATIONS ÉLECTRIQUES ET LES MODULES D'INTERFACE (supervision, matrice de commutation et cartes de lignes). Pour soulever le châssis, utiliser un appareil élévateur. Quatre personnes au moins sont nécessaires pour positionner dans le rack le châssis vidé de ses éléments.
PELIGRO	No trate de levantar un chasis Brocade NetIron XMR-32. Es extremadamente pesado. QUITE PRIMERO LOS MÓDULOS DE INTERFAZ Y DE ALIMENTACIÓN (administración, matriz de conmutación, y todas las tarjetas de línea). Utilice un elevador mecánico para levantar el chasis. Hacen falta cuatro personas o más para colocar el chasis no poblado en el interior del armazón.

DANGER	Do not attempt to lift a Brocade MLX Series-32 chassis. It is extremely heavy. REMOVE THE POWER SUPPLIES AND INTERFACE MODULES FIRST (management, switch fabric, and all line cards). Use a mechanical lifting device to lift the chassis. Four or more people are required to position the unpopulated chassis into the rack.
GEFAHR	Nicht versuchen, ein Brocade MLX Series-32 Chassis anzuheben. Es ist sehr schwer. ZUERST DIE STROMVERSORGUNGEN UND SCHNITTSTELLENMODULE ENTFERNEN (Management, Switch-Fabric und alle Line-Cards). Das Chassis mit Hilfe einer mechanischen Hebevorrichtung anheben. Mindestens vier Personen sind erforderlich, um das unbeladene Chassis im Rack zu positionieren.
DANGER	Ne jamais tenter de soulever un châssis Brocade MLX Series-32 car il est alors extrêmement lourd. DÉPOSER AU PRÉALABLE LES ALIMENTATIONS ÉLECTRIQUES ET LES MODULES D'INTERFACE (supervision, matrice de commutation et cartes de lignes). Pour soulever le châssis, utiliser un appareil élévateur. Quatre personnes au moins sont nécessaires pour positionner dans le rack le châssis vidé de ses éléments.
PELIGRO	No trate de levantar un chasis Brocade MLX Series-32. Es extremadamente pesado. QUITE PRIMERO LOS MÓDULOS DE INTERFAZ Y DE ALIMENTACIÓN (administración, matriz de conmutación, y todas las tarjetas de línea). Utilice un elevador mecánico para levantar el chasis. Hacen falta cuatro personas o más para colocar el chasis no poblado en el interior del armazón.

DANGER	High Touch Current. Earth connection essential before connecting supply (Brocade NetIron XMR 32000, Brocade MLX Series-32).
GEFAHR	Hoher Ableitstrom. Vor Anschluss ans Netz Schutzterdung herstellen. (Brocade NetIron XMR 32000, Brocade MLX Series-32)
DANGER	Courant de fuite élevé. Mise à la terre obligatoire avant la connexion de l'alimentation (Brocade NetIron XMR 32000, Brocade MLX Series-32).
PELIGRO	Alta tensión al tacto. La conexión a tierra es esencial antes de conectar la alimentación (Brocade NetIron XMR 32000, Brocade MLX Series-32).

DANGER	The ports labeled BITS1, BITS2 are safety extra low voltage (SELV) circuits. SELV circuits should only be connected to other SELV circuits. All interconnected equipment should be located in the same building as the unit.
GEFAHR	Die Anschlüsse BITS1, BITS2 sind SELV (Safety Extra Low Voltage)- Stromkreise. SELV-Stromkreise sollten nur an andere SELV-Stromkreise angeschlossen werden. Alle mit einander verbundenen Geräte sollten sich im gleichen Gebäude wie die Einheit befinden.
DANGER	Les ports marqués BITS1, BITS2 sont des circuits de sécurité à très basse tension (SELV). Ces circuits doivent uniquement être connectés à d'autres circuits SELV. Tous les équipements interconnectés via ces ports doivent se trouver dans le même bâtiment que l'unité.
PELIGRO	Los puertos que llevan las marcas BITS1, BITS2 son circuitos de bajo voltaje de seguridad extra (SELV, por sus siglas en inglés). Los circuitos SELV sólo deben conectarse a otros circuitos SELV. Todos los equipos interconectados deben estar situados en el mismo edificio que la unidad.

C Dangers

DANGER	The intra-building port or ports of the equipment or subassembly is suitable for connection to intra-building or unexposed wiring or cabling only. The intra-building port or ports of the equipment or subassembly MUST NOT be metallically connected to interfaces that connect to the outside plant (OSP) or its wiring. These interfaces are designed for use as intra-building interfaces only (Type 2 or Type 4 ports as described in GR-1089-CORE, Issue 5) and require isolation from the exposed OSP cabling. The addition of Primary Protectors is not sufficient protection in order to connect these interfaces metallically to OSP wiring.
GEFAHR	Die gebäudeinternen Anschlüsse des Geräts bzw. der Unterbaugruppe sind nur zur Verbindung mit gebäudeinternen bzw. nicht freiliegenden Drähten und Kabeln geeignet. Die gebäudeinternen Anschlüsse des Geräts bzw. der Baugruppe DÜRFEN NICHT metallisch mit Schnittstellen verbunden werden, die an Außenbereiche (OSP) oder deren Verdrahtung angeschlossen sind. Diese Schnittstellen sind ausschließlich zur Verwendung als gebäudeinterne Schnittstellen ausgelegt (Anschlüsse des Typs 2 oder 4 gemäß GR-1089-CORE, Ausgabe 5) und müssen von den freiliegenden OSP-Kabeln isoliert werden. Eine hinzugefügte Primärschutzeinrichtung ist kein ausreichender Schutz gegen den metallischen Anschluss dieser Schnittstellen an die OSP-Verdrahtung
DANGER	Le ou les ports réservés à l'utilisation de l'appareil à l'intérieur d'un bâtiment (intra-building) sont uniquement destinés à une connexion en intérieur ou avec du câblage non exposé aux intempéries. Il est rigoureusement interdit d'établir un contact métallique entre le ou les ports réservés à l'utilisation de l'équipement à l'intérieur d'un bâtiment et des interfaces connectées à des installations extérieures(OSP) ou à leur câblage. Ces interfaces sont en effet destinées uniquement à un usage en intérieur (les ports de type 2 ou 4 sont décrits dans le document GR-1089-CORE, volume 5) ; elles doivent être isolées de tout câblage exposé à l'extérieur. L'ajout de dispositifs de protection primaire n'offre pas une protection suffisante pour permettre de raccorder par contact métallique ces interfaces à un câblage ou une installation en extérieur.
PELIGRO	Los puertos del equipo o del sistema secundario situados en el interior de un edificio únicamente podrán conectarse a instalaciones eléctricas o cableados que se encuentren dentro del edificio o que no estén expuestos. Los puertos del equipo o del sistema secundario situados en el interior del edificio NO DEBEN conectarse metálicamente a interfaces que se encuentren conectadas a la planta exterior (OSP por sus siglas en inglés) o a su sistema eléctrico. Dichas interfaces han sido diseñadas para uso exclusivo en el interior de un edificio (puertos Tipo 2 o Tipo 4, según lo descrito en GR-1089-CORE, Número 5) y deben aislarse del cableado de la OSP expuesto. La incorporación de Protectores Primarios no proporciona protección suficiente para conectar dichas interfaces metálicamente al sistema eléctrico de la OSP.