

53-1003263-03
22 May 2015

Brocade NetIron CES 2000 Series and NetIron CER 2000 Series

Hardware Installation Guide

Supported Release: Multi-Service IronWare R05.8.00b

BROCADE 

© 2015, Brocade Communications Systems, Inc. All Rights Reserved.

ADX, Brocade, Brocade Assurance, the B-wing symbol, DCX, Fabric OS, HyperEdge, ICX, MLX, MyBrocade, OpenScript, The Effortless Network, VCS, VDX, Vplane, and Vyatta are registered trademarks, and Fabric Vision and vADX are trademarks of Brocade Communications Systems, Inc., in the United States and/or in other countries. Other brands, products, or service names mentioned may be trademarks of others.

Notice: This document is for informational purposes only and does not set forth any warranty, expressed or implied, concerning any equipment, equipment feature, or service offered or to be offered by Brocade. Brocade reserves the right to make changes to this document at any time, without notice, and assumes no responsibility for its use. This informational document describes features that may not be currently available. Contact a Brocade sales office for information on feature and product availability. Export of technical data contained in this document may require an export license from the United States government.

The authors and Brocade Communications Systems, Inc. assume no liability or responsibility to any person or entity with respect to the accuracy of this document or any loss, cost, liability, or damages arising from the information contained herein or the computer programs that accompany it.

The product described by this document may contain open source software covered by the GNU General Public License or other open source license agreements. To find out which open source software is included in Brocade products, view the licensing terms applicable to the open source software, and obtain a copy of the programming source code, please visit <http://www.brocade.com/support/oscd>.

Contents

- Preface..... 7**
 - Document conventions.....7
 - Text formatting conventions.....7
 - Command syntax conventions.....7
 - Notes, cautions, and warnings.....8
 - Brocade resources.....9
 - Contacting Brocade Technical Support.....9
 - Document feedback.....10

- About This Document..... 11**
 - Audience.....11
 - Supported hardware and software.....11
 - Supported software.....12
 - Notice to the reader.....12
 - Related publications.....13

- Product Overview..... 15**
 - Introduction.....15
 - Product overview.....20
 - Software features.....21
 - Upgrade applications.....21
 - Hardware features.....22
 - Brocade NetIron CES Series 2024C-4X.....22
 - Brocade NetIron CES Series 2024F-4X.....23
 - Brocade NetIron CES Series 2024C.....23
 - Brocade NetIron CES Series 2024F.....23
 - Brocade NetIron CES Series 2048C.....24
 - Brocade NetIron CES Series 2048CX.....24
 - Brocade NetIron CES Series 2048F.....25
 - Brocade NetIron CES Series 2048FX.....25
 - Brocade NetIron CER Series 2024C.....26
 - Brocade NetIron CER Series 2024F.....26
 - Brocade NetIron CER Series 2048C.....27
 - Brocade NetIron CER Series 2048CX.....27
 - Brocade NetIron CER Series 2048F.....28
 - Brocade NetIron CER Series 2048FX.....28
 - Control features.....29
 - Network interfaces.....34
 - Power supplies.....34
 - Cooling system and fans.....36

- Connecting to a Network Device 37**
 - Password assignment.....37
 - IP address configuration.....38
 - Support of sub-net masks.....39
 - Assigning an IP address to a management interface.....39

Assigning an IP address to an interface, virtual interface, or loopback.....	40
Enabling and disabling the interfaces.....	41
Management port function overview.....	41
Device connection.....	41
Installation.....	43
System unpacking.....	43
Package contents.....	43
General requirements.....	43
Summary of installation tasks.....	44
Installation precautions.....	45
Lifting precautions.....	45
Power precautions.....	45
Installation site preparation.....	47
Cabling infrastructure.....	47
Installation location.....	47
Redundant power supply installation.....	48
Installing an AC power supply.....	48
Installing a DC power supply.....	50
Device installation.....	53
Installing the device on a desktop.....	53
Installing the device in a rack.....	53
System power.....	57
Powering on the system.....	58
Operation verification.....	58
Verifying proper operation.....	59
Observing the power status LEDs.....	59
PC or terminal attachment.....	61
Attaching a PC or terminal.....	61
Device Management Applications Familiarization.....	63
Management application overview.....	63
CLI Functionality.....	63
Online help.....	64
Command completion.....	64
Scroll control.....	64
Line editing commands.....	64
Searching and filtering output from CLI commands.....	65
Hardware Specifications.....	71
Power specifications.....	71
Physical dimensions.....	72
Operating environment.....	74
Storage environment.....	74
Cooling.....	75
Safety agency approvals.....	75
Electromagnetic approvals.....	75
Port specifications.....	75
Console port pin assignments.....	76
Management port pin assignments.....	77
Hardware Maintenance.....	79
Hardware maintenance schedule.....	79

Power supply replacement.....	79
Installation precautions and warnings.....	80
Determining which power supply failed.....	80
AC power supply	81
Power supplies for the devices.....	81
Verifying proper operation.....	90
10-Gigabit Ethernet module installation or replacement.....	91
Removing a 2 x10-Gigabit Ethernet module.....	91
Installing a 2 x10-Gigabit Ethernet Module.....	91
Replacing the fan tray.....	92
Copper or Fiber optic module replacement.....	93
Removing a Copper or fiber optic module.....	93
Installing a new Copper or fiber optic module.....	94
Cabling a fiber optic module.....	94
Tunable 10 GbE DWDM SFP+.....	95
Fiber optic connector cleaning.....	95
Regulatory Statements.....	97
BSMI statement (Taiwan).....	97
Canadian requirements.....	97
China CC statement.....	98
Europe and Australia (CISPR 22 Class A Warning).....	98
FCC warning (US only).....	99
Germany.....	99
KCC statement (Republic of Korea).....	99
VCCI statement.....	99
Caution and Danger Notices.....	101
Cautions.....	101
Danger Notices.....	108
Index.....	115

Preface

- Document conventions..... 7
- Brocade resources..... 9
- Contacting Brocade Technical Support..... 9
- Document feedback..... 10

Document conventions

The document conventions describe text formatting conventions, command syntax conventions, and important notice formats used in Brocade technical documentation.

Text formatting conventions

Text formatting conventions such as boldface, italic, or Courier font may be used in the flow of the text to highlight specific words or phrases.

Format	Description
bold text	Identifies command names Identifies keywords and operands Identifies the names of user-manipulated GUI elements Identifies text to enter at the GUI
<i>italic text</i>	Identifies emphasis Identifies variables Identifies document titles
<code>Courier font</code>	Identifies CLI output Identifies command syntax examples

Command syntax conventions

Bold and italic text identify command syntax components. Delimiters and operators define groupings of parameters and their logical relationships.

Convention	Description
bold text	Identifies command names, keywords, and command options.
<i>italic text</i>	Identifies a variable.
value	In Fibre Channel products, a fixed value provided as input to a command option is printed in plain text, for example, --show WWN.

Convention	Description
[]	Syntax components displayed within square brackets are optional. Default responses to system prompts are enclosed in square brackets.
{ x y z }	A choice of required parameters is enclosed in curly brackets separated by vertical bars. You must select one of the options. In Fibre Channel products, square brackets may be used instead for this purpose.
x y	A vertical bar separates mutually exclusive elements.
< >	Nonprinting characters, for example, passwords, are enclosed in angle brackets.
...	Repeat the previous element, for example, <i>member[member...]</i> .
\	Indicates a “soft” line break in command examples. If a backslash separates two lines of a command input, enter the entire command at the prompt without the backslash.

Notes, cautions, and warnings

Notes, cautions, and warning statements may be used in this document. They are listed in the order of increasing severity of potential hazards.

NOTE

A Note provides a tip, guidance, or advice, emphasizes important information, or provides a reference to related information.

ATTENTION

An Attention statement indicates a stronger note, for example, to alert you when traffic might be interrupted or the device might reboot.



CAUTION

A Caution statement alerts you to situations that can be potentially hazardous to you or cause damage to hardware, firmware, software, or data.



DANGER

A Danger statement indicates conditions or situations that can be potentially lethal or extremely hazardous to you. Safety labels are also attached directly to products to warn of these conditions or situations.

Brocade resources

Visit the Brocade website to locate related documentation for your product and additional Brocade resources.

You can download additional publications supporting your product at www.brocade.com. Select the Brocade Products tab to locate your product, then click the Brocade product name or image to open the individual product page. The user manuals are available in the resources module at the bottom of the page under the Documentation category.

To get up-to-the-minute information on Brocade products and resources, go to [MyBrocade](#). You can register at no cost to obtain a user ID and password.

Release notes are available on [MyBrocade](#) under Product Downloads.

White papers, online demonstrations, and data sheets are available through the [Brocade website](#).

Contacting Brocade Technical Support

As a Brocade customer, you can contact Brocade Technical Support 24x7 online, by telephone, or by e-mail. Brocade OEM customers contact their OEM/Solutions provider.

Brocade customers

For product support information and the latest information on contacting the Technical Assistance Center, go to <http://www.brocade.com/services-support/index.html>.

If you have purchased Brocade product support directly from Brocade, use one of the following methods to contact the Brocade Technical Assistance Center 24x7.

Online	Telephone	E-mail
<p>Preferred method of contact for non-urgent issues:</p> <ul style="list-style-type: none"> • My Cases through MyBrocade • Software downloads and licensing tools • Knowledge Base 	<p>Required for Sev 1-Critical and Sev 2-High issues:</p> <ul style="list-style-type: none"> • Continental US: 1-800-752-8061 • Europe, Middle East, Africa, and Asia Pacific: +800-AT FIBREE (+800 28 34 27 33) • For areas unable to access toll free number: +1-408-333-6061 • Toll-free numbers are available in many countries. 	<p>support@brocade.com</p> <p>Please include:</p> <ul style="list-style-type: none"> • Problem summary • Serial number • Installation details • Environment description

Brocade OEM customers

If you have purchased Brocade product support from a Brocade OEM/Solution Provider, contact your OEM/Solution Provider for all of your product support needs.

- OEM/Solution Providers are trained and certified by Brocade to support Brocade® products.
- Brocade provides backline support for issues that cannot be resolved by the OEM/Solution Provider.

- Brocade Supplemental Support augments your existing OEM support contract, providing direct access to Brocade expertise. For more information, contact Brocade or your OEM.
- For questions regarding service levels and response times, contact your OEM/Solution Provider.

Document feedback

To send feedback and report errors in the documentation you can use the feedback form posted with the document or you can e-mail the documentation team.

Quality is our first concern at Brocade and we have made every effort to ensure the accuracy and completeness of this document. However, if you find an error or an omission, or you think that a topic needs further development, we want to hear from you. You can provide feedback in two ways:

- Through the online feedback form in the HTML documents posted on www.brocade.com.
- By sending your feedback to documentation@brocade.com.

Provide the publication title, part number, and as much detail as possible, including the topic heading and page number if applicable, as well as your suggestions for improvement.

About This Document

- Audience..... 11
- Supported hardware and software..... 11
- Notice to the reader..... 12
- Related publications..... 13

Audience

This document is designed for system administrators with a working knowledge of Layer 2 and Layer 3 switching and routing.

If you are using a Brocade device, you should be familiar with the following protocols if applicable to your network - IP, RIP, OSPF, BGP, ISIS, IGMP, PIM, MPLS, and VRRP.

Supported hardware and software

The following hardware platforms are supported by this release of this guide:

TABLE 1 Supported devices

Brocade NetIron XMR Series	Brocade MLX Series	NetIron CES 2000 and NetIron CER 2000 Series
Brocade NetIron XMR 4000	Brocade MLX-4	Brocade NetIron CES 2024C
Brocade NetIron XMR 8000	Brocade MLX-8	Brocade NetIron CES 2024C-4X
Brocade NetIron XMR 16000	Brocade MLX-16	Brocade NetIron CER 2024C-4X-RT
Brocade NetIron XMR 32000	Brocade MLX-32	Brocade NetIron CES 2024F
	Brocade MLXe-4	Brocade NetIron CES 2024F-4X
	Brocade MLXe-8	Brocade NetIron CER 2024F-4X-RT
	Brocade MLXe-16	Brocade NetIron CES 2048C
	Brocade MLXe-32	Brocade NetIron CES 2048CX
		Brocade NetIron CES 2048F
		Brocade NetIron CES 2048FX
		Brocade NetIron CER 2024C
		Brocade NetIron CER-RT 2024C
		Brocade NetIron CER 2024F
		Brocade NetIron CER-RT 2024F
		Brocade NetIron CER 2048C
		Brocade NetIron CER-RT 2048C
		Brocade NetIron CER 2048CX
		Brocade NetIron CER-RT 2048CX
		Brocade NetIron CER 2048F
		Brocade NetIron CER-RT 2048F
		Brocade NetIron CER 2048FX
		Brocade NetIron CER-RT 2048FX

Supported software

Supporting *Multi-Service IronWare R05.8.00*.

Notice to the reader

This document may contain references to the trademarks of the following corporations. These trademarks are the properties of their respective companies and corporations.

These references are made for informational purposes only.

Corporation	Referenced Trademarks and Products
Microsoft Corporation	Internet Explorer

Corporation	Referenced Trademarks and Products
Mozilla Corporation	Mozilla Firefox
Oracle Corporation	Java Runtime Environment

Related publications

For the latest edition of these documents, which contain the most up-to-date information, see Documentation at <http://www.brocade.com/ethernetproducts>

- *Multi-Service IronWare Administration Guide*
- *Multi-Service IronWare Security Configuration Guide*
- *Multi-Service IronWare Switching Configuration Guide*
- *Multi-Service IronWare Routing Configuration Guide*
- *Multi-Service IronWare Traffic Management Configuration Guide*
- *Multi-Service IronWare Multicast Configuration Guide*
- *Multi-Service IronWare Multiprotocol Label Switch (MPLS) Configuration Guide*
- *Multi-Service IronWare Software Defined Networking (SDN) Guide*
- *Brocade MLX Series and NetIron Family YANG Guide*
- *Brocade MLX Series and NetIron XMR Series Diagnostic Reference*
- *Unified IP MIB Reference*
- *Multi-Service IronWare Software Upgrade Procedures for Brocade MLX Series routers*
- *Brocade MLXe Series Installation Guide*
- *Brocade MLX Series and Brocade NetIron XMR Installation Guide*
- *Brocade NetIron CES 2000 Series and Brocade NetIron CER 2000 Series Hardware Installation Guide*

Related publications

Product Overview

- [Introduction.....](#) 15
- [Product overview.....](#) 20
- [Software features.....](#) 21
- [Upgrade applications.....](#) 21
- [Hardware features.....](#) 22

Introduction

Network planners today have to expand and extend the range of services offered further into the edge of the network. This requires extending the intelligence and high-touch processing capabilities to the network edge-- whether in a metro network, a campus network or in a data center. The challenge at the edge of the network is compounded by the need to flexibly define and easily manage customer services in an intuitive manner. Further, of many rollouts. Whether deployed from a central office or from remote huts, space is an important constraint for such providers.

In order to meet these challenges, the *Netlron Carrier Ethernet Switch (CES) 2000 Series* and *Netlron Carrier Ethernet Router (CER) 2000 Series* were purpose-built to offer flexible, secure and advanced processing capabilities in a compact form factor. The Brocade Netlron CES Series 2000 and Brocade Netlron CER Series 2000 Series are compact 1 RU, multi-service edge or aggregation devices with a powerful set of capabilities chosen to combine performance with rich functionality at the edge of the network. The Brocade Netlron CES Series 2000 Series and Brocade Netlron CER Series 2000 Series devices offer network planners a rich set of high-performance IPv4, Classic Layer 2, Provider Bridge (PB) and Provider Backbone Bridge (PBB) functionalities in the same device. With these capabilities, a diverse set of applications ranging from metro edge networks, ISPs, data centers, large enterprises, government networks, and education or research can be addressed with the Brocade Netlron CES Series 2000 Series and Brocade Netlron CER Series 2000 Series.

This guide includes procedures for installing the hardware and configuring essential, basic parameters such as permanent passwords and IP addresses. The basic software configuration procedures show how to perform tasks using the CLI. This guide also includes instructions for managing and maintaining the Netlron Carrier Ethernet Switch (CES) and Netlron Carrier Ethernet Router (CER) hardware.

There are eight flavors to the Netlron Carrier Ethernet Switch (CES) 2000 Series:

- Brocade Netlron CES Series 2024C-4X -- accommodates 24-port 10/100/1000 RJ45 model with 4 combination 100/1000 Hybrid Fiber (HF) ports and 4x10G SFP+ uplinks
- Brocade Netlron CES Series 2024F-4X -- accommodates 24-port 100/1000 Hybrid Fiber (HF) model with 4 combination 10/100/1000 RJ45 ports and 4x10G SFP+ uplinks
- Brocade Netlron CES Series 2024C -- accommodates 24-port 10/100/1000 RJ45 model with 4 combination 100/1000 Hybrid Fiber (HF) ports and an optional field upgradeable 2x10G uplink slot
- Brocade Netlron CES Series 2024F -- accommodates 24-port 100/1000 Hybrid Fiber (HF) model with 4 combination 10/100/1000 RJ45 ports and an optional field upgradeable 2x10G XFP uplink slot
- Brocade Netlron CES Series 2048C -- accommodates 48-port 10/100/1000 RJ45 model with 4 combination 100/1000 Hybrid Fiber (HF) ports
- Brocade Netlron CES Series 2048CX -- accommodates 48-port 10/100/1000 RJ45 model with 2x10G XFP uplink ports

- Brocade NetIron CES Series 2048F -- accommodates 48-port 100/1000 Hybrid Fiber (HF) model
- Brocade NetIron CES Series 2048FX -- accommodates 48-port 100/1000 Hybrid Fiber (HF) model with 2x10G XFP uplink ports

FIGURE 1 Brocade NetIron CES Series 2024C-4X



FIGURE 2 Brocade NetIron CES Series 2024F-4X



FIGURE 3 Brocade NetIron CES Series 2024C



FIGURE 4 Brocade NetIron CES Series 2024F



FIGURE 5 Brocade NetIron CES Series 2048C

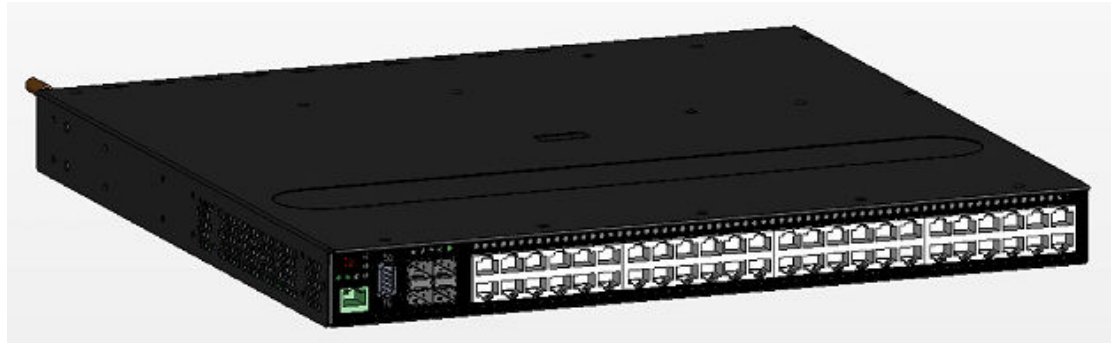

FIGURE 6 Brocade NetIron CES Series 2048F



FIGURE 7 Brocade NetIron CES Series 2048CX



FIGURE 8 Brocade NetIron CES Series 2048FX

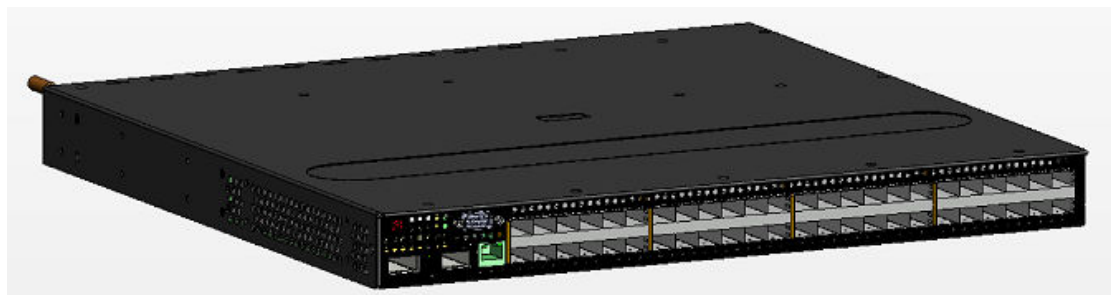

There are also fourteen models in the NetIron Carrier Ethernet Router (CER and CER-RT) 2000 Series:

- Brocade NetIron CER Series 2024C-4X -RT -- accommodates 24-port 10/100/1000 RJ45 model with 4 combination 100/1000 Hybrid Fiber (HF) ports and 4x10G SFP+ uplinks. This device has the ability to simultaneously store up to 1.5 million IPv4 routes and up to 256,000 IPv6 routes
- Brocade NetIron CER Series 2024F-4X-RT -- accommodates 24-port 100/1000 Hybrid Fiber (HF) model with 4 combination 10/100/1000 RJ45 ports and 4x10G SFP+ uplinks. This device has the ability to simultaneously store up to 1.5 million IPv4 routes and up to 256,000 IPv6 routes
- Brocade NetIron CER Series 2024C -- accommodates 24-port 10/100/1000 Copper RJ45 model with 4 combination 100/1000 Hybrid Fiber (HF) ports and an optional field upgradeable 2x10G uplink slot
- Brocade NetIron CER Series- RT 2024C -- accommodates 24-port 10/100/1000 Copper RJ45 model with 4 combination 100/1000 Hybrid Fiber (HF) ports and an optional field upgradeable 2x10G uplink slot. This device has the ability to simultaneously store up to 1.5 million IPv4 routes and up to 256,000 IPv6 routes
- Brocade NetIron CER Series 2024F -- accommodates 24-port 100/1000 Hybrid Fiber (HF) model with 4 combination 10/100/1000 RJ45 ports and an optional field upgradeable 2x10G XFP uplink slot
- Brocade NetIron CER Series- RT 2024F -- accommodates 24-port 100/1000 Hybrid Fiber (HF) model with 4 combination 10/100/1000 RJ45 ports and an optional field upgradeable 2x10G XFP uplink slot. This device has the ability to simultaneously store up to 1.5 million IPv4 routes and up to 256,000 IPv6 routes
- Brocade NetIron CER Series 2048C -- accommodates 48-port 10/100/1000 Copper RJ45 model with 4 combination 100/1000 Hybrid Fiber (HF) ports
- Brocade NetIron CER Series- RT 2048C -- accommodates 48-port 10/100/1000 Copper RJ45 model with 4 combination 100/1000 Hybrid Fiber (HF) ports. This device has the ability to simultaneously store up to 1.5 million IPv4 routes and up to 256,000 IPv6 routes
- Brocade NetIron CER Series 2048F -- accommodates 48-port 100/1000 Hybrid Fiber (HF) model
- Brocade NetIron CER Series- RT 2048F -- accommodates 48-port 100/1000 Hybrid Fiber (HF) model This device has the ability to simultaneously store up to 1.5 million IPv4 routes and up to 256,000 IPv6 routes
- Brocade NetIron CER Series 2048CX -- accommodates 48-port 10/100/1000 RJ45 model with 2x10G XFP uplink ports
- Brocade NetIron CER Series- RT2048CX -- accommodates 48-port 10/100/1000 RJ45 model with 2x10G XFP uplink ports. This device has the ability to simultaneously store up to 1.5 million IPv4 routes and up to 256,000 IPv6 routes
- Brocade NetIron CER Series 2048FX -- accommodates 48-port 100/1000 Hybrid Fiber (HF) model with 2x10G XFP uplink ports
- Brocade NetIron CER Series- RT 2048FX -- accommodates 48-port 100/1000 Hybrid Fiber (HF) model with 2x10G XFP uplink ports. This device has the ability to simultaneously store up to 1.5 million IPv4 routes and up to 256,000 IPv6 routes

FIGURE 9 Brocade NetIron CER Series 2024C-4X-RT



FIGURE 10 Brocade NetIron CER Series 2024F-4X-RT



FIGURE 11 Brocade NetIron CER Series 2024C



FIGURE 12 Brocade NetIron CER Series 2024F



FIGURE 13 Brocade NetIron CER Series 2048C

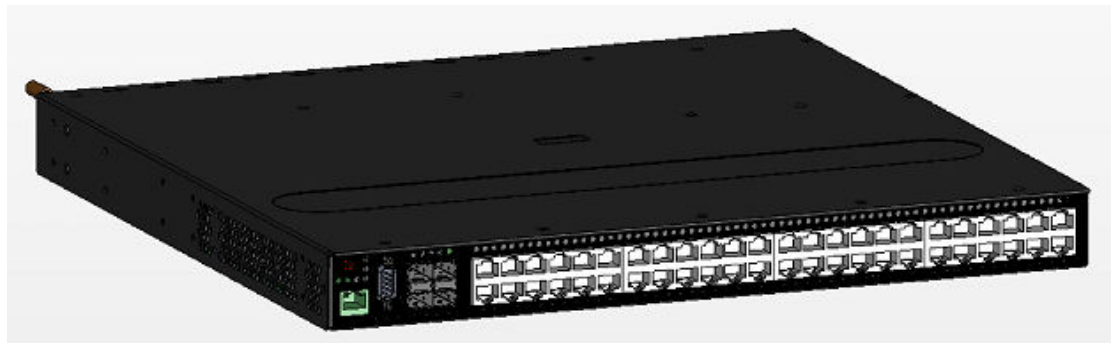

FIGURE 14 Brocade NetIron CER Series 2048F



FIGURE 15 Brocade NetIron CER Series 2048CX



FIGURE 16 Brocade NetIron CER Series 2048FX



Product overview

The Brocade NetIron CES Series 2000 Series is a compact 1 RU, multi-service edge or aggregation switch with a powerful set of capabilities that combine performance with rich functionality at the network edge. The Brocade NetIron CES Series 2000 Series switch offers network planners a broad set of high performance IPv4, Classic Layer 2, Provider Bridge (PB) and Provider Backbone Bridge (PBB) functionalities in the same device. With these capabilities, the Brocade NetIron CES Series 2000 Series addresses a diverse set of applications in metro edge networks, ISP networks, mobile backhaul networks, data centers, large enterprises, government networks and education or research.

FIGURE 17 Brocade NetIron CES Series 2000 Series switch

The Brocade NetIron CER Series 2000 Series is a compact 1 RU, IP, MPLS, and multi-VRF enabled metro router offering a broad set of capabilities including high performance IPv4 and IPv6 routing, Advanced Layer 2, Multiprotocol Label Switching (MPLS), Provider Bridge (PB) and Provider Backbone Bridge (PBB) functionalities in the same device. With these capabilities, the Brocade NetIron CER Series 2000 Series addresses a diverse set of needs in service provider networks and enterprise applications, as well as metro edge networks and small data centers.

FIGURE 18 Brocade NetIron CER Series 2000 Series router

Software features

Software features differ depending on the software package that is purchased with the device. The BASE package on the Brocade NetIron CES Series 2000 devices support full Layer 2 Switching and base Layer 3 (RIP and static routes). The Metro Edge Premium (ME_PREM) package support full Layer 2 Switching, base Layer 3 (RIP and static routes), Provider Bridges (IEEE 802.1ad), Provider Backbone Bridges (IEEE 802.1ah), OSPF, ISIS, and Connectivity Fault Management (IEEE 802.1ag) and Service OAM. The Layer 3 Premium (L3_PREM) packages support full Layer 2 Switching, base Layer 3 (RIP and static routes), and full Layer 3 including BGP, ISIS and OSPF.

The BASE package on the Brocade NetIron CER Series 2000 devices support full Layer 2 Switching and full Layer 3 (RIP, OSPF, ISIS, and BGP). It also includes virtual routing in non-MPLS environments via Multi-VRF. The Advanced Services Premium (ADV_SVCS_PREM) package includes MPLS, Layer 2 VPNs using VPLS and VLLs, Provider Bridges (IEEE 802.1ad), Provider Backbone Bridges (IEEE 802.1ah), Connectivity Fault Management (IEEE 802.1ag) and Service OAM, along with Ethernet Service Instance (ESI). The Brocade NetIron CER -RT features full MPLS capabilities as the original Brocade NetIron CER, and has the ability to simultaneously store up to 1.5 million IPv4 routes and up to 256,000 IPv6 routes.

All Brocade NetIron CES Series 2000 and Brocade NetIron CER Series 2000 devices can be upgraded to premium packages.

Upgrade applications

You can convert (upgrade) your Brocade NetIron CES Series 2000 Series device. Converting your Brocade NetIron CES Series 2000 Series device allows you to run a software image that contains additional capabilities available in premium packages.

To convert your Brocade NetIron CES Series and Brocade NetIron CER Series 2000 Series devices, you need an upgrade kit. The kit includes a Dual Inline Package (DIP) key, Multi-Service IronWare software, upgrade instructions, and other items. Alternatively, you can order a Brocade NetIron CES Series or Brocade NetIron CER Series 2000 Series device with the premium software already installed. For more information, refer to the *Multi-Service IronWare Software Upgrade Guide*.

TABLE 2 Upgrade kits

Brocade part number	Description
NI-CES-2024-MEU	Metro Edge Premium upgrade for Brocade NetIron CES Series 2000 Series 24-port models.
NI-CES-2024-L3U	L3 Premium upgrade for Brocade NetIron CES Series 2000 Series 24-port models.
NI-CES-2048-MEU	Metro Edge Premium upgrade for Brocade NetIron CES Series 2000 Series 48-port models.
NI-CES-2048-L3U	L3 Premium upgrade for Brocade NetIron CES Series 2000 Series 48-port models.
NI-CER-2024-ADVU	Advanced Services Premium License for Brocade NetIron CER Series 24-port models.
NI-CER-2048-ADVU	Advanced Services Premium License for Brocade NetIron CER Series 48-port models.

Hardware features

This section describes the physical characteristics of the Brocade NetIron CES Series 2000 and Brocade NetIron CER Series 2000 Series devices. For details about physical dimensions, power supply specifications, and pinouts, refer to the [Hardware Specifications](#) on page 71.

The following figures show the front panels of the various NetIron 2024 and 2048 devices.

NOTE

This is only a representative sample. For the exact model, look at the faceplate on the front of the device. Both CER and CES devices have similar look and feel.

Brocade NetIron CES Series 2024C-4X

The Brocade NetIron CES Series 2024C-4X switch has twenty-four 10/100/1000 MbE RJ45 ports plus four combination 100/ 1000 MbE SFP ports, 4-port 10 GbE SFP+ module, one DB9 serial management interface port labeled Console, one 10/100/1000 MbE RJ45 out-of-band management port, one resilient six-unit fan tray, and two AC power supply bays for 1+1 redundancy with one 500W AC power supply included.

FIGURE 19 Brocade NetIron CES Series 2024C-4X device



- | | |
|---|---|
| 1 | 10 GbE SFP+ ports |
| 2 | Four combination 100/1000 MbE SFP ports |
| 3 | Twenty-four 10/100/1000 MbE RJ45 ports |

Brocade Netron CES Series 2024F-4X

The Brocade Netron CES Series 2024F-4X has twenty-four 100/1000 MbE SFP ports plus four combination 10/100/1000 MbE RJ45 ports, 4-port 10 GbE SFP+ module, one DB9 serial management interface port labeled Console, one 10/100/1000 MbE RJ45 out-of-band management port, one resilient six-unit fan tray, and two AC power supply bays for 1+1 redundancy with one 500W AC power supply included.

FIGURE 20 Brocade Netron CES Series 2024F-4X device

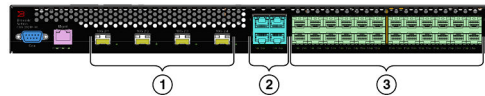

-
- 1 10 GbE SFP+ ports
-
- 2 Four combination 10/100/1000 MbE RJ45 ports
-
- 3 Twenty-four 100/1000 MbE SFP ports
-

Brocade Netron CES Series 2024C

The Brocade Netron CES Series 2024C switch has twenty-four 10/100/1000 MbE RJ45 ports plus four combination 100/ 1000 MbE SFP ports, one module slot for an optional field upgradable 2-port 10 GbE XFP module, one DB9 serial management interface port labeled Console, one 10/100/1000 MbE RJ45 out-of-band management port, one resilient six-unit fan tray, and two AC power supply bays for 1+1 redundancy with one 500W AC power supply included.

FIGURE 21 Brocade Netron CES Series 2024C device with the optional 2 ports of 10-G XFP uplink

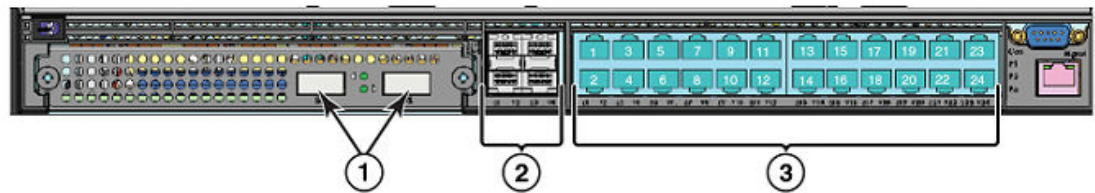

-
- 1 Optional 10 GbE XFP ports
-
- 2 Four combination 100/1000 MbE SFP ports
-
- 3 Twenty-four 10/100/1000 MbE RJ45 ports
-

Brocade Netron CES Series 2024F

The Brocade Netron CES Series 2024F has twenty-four 100/1000 MbE SFP ports plus four combination 10/100/1000 MbE RJ45 ports, one module slot for an optional field upgradable 2-port 10 GbE XFP module, one DB9 serial management interface port labeled Console, one 10/100/1000 MbE

RJ45 out-of-band management port, one resilient six-unit fan tray, and two AC power supply bays for 1+1 redundancy with one 500W AC power supply included.

FIGURE 22 Brocade NetIron CES Series 2024F device

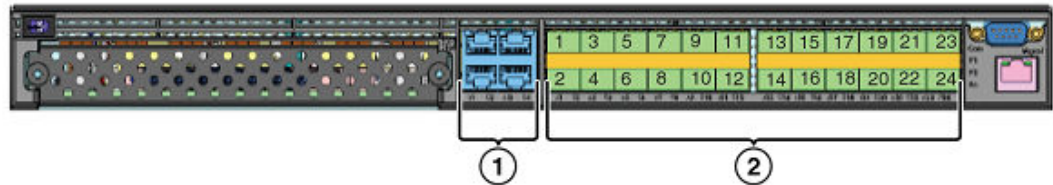

-
- 1 Four combination 10/100/1000 MbE RJ45 ports with support for optional 10GbE XFP ports
-
- 2 Twenty-four 100/1000 MbE SFP ports
-

Brocade NetIron CES Series 2048C

Brocade NetIron CES Series 2048C (Copper) switch has forty-eight 10/100/1000 MbE RJ45 ports plus four combination 100/ 1000 MbE SFP ports, one DB9 serial management interface port labeled Console, one 10/100/1000 MbE RJ45 out-of-band management port, one resilient six-unit fan tray, and two AC power supply bays for 1+1 redundancy with one 500W AC power supply included.

FIGURE 23 Brocade NetIron CES Series 2048C device

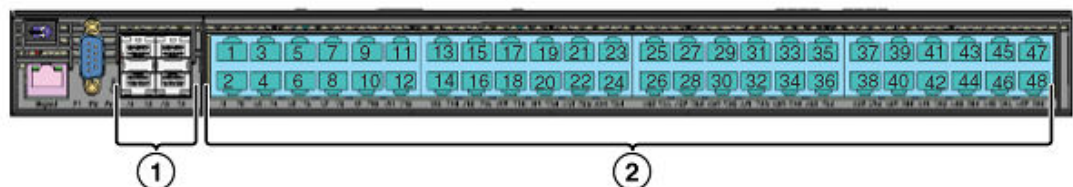

-
- 1 Four combination 100/1000 MbE SFP ports
-
- 2 Forty-eight 10/100/1000 MbE RJ45 ports
-

Brocade NetIron CES Series 2048CX

Brocade NetIron CES Series 2048CX (Copper) has forty-eight 10/100/1000 MbE RJ45 ports plus two 10 GbE XFP ports, one DB9 serial management interface port labeled Console, one 10/100/1000 MbE RJ45 out-of-band management port, one resilient six-unit fan tray, and two AC power supply bays for 1+1 redundancy with one 500W AC power supply included.

FIGURE 24 Brocade NetIron CES Series 2048CX device

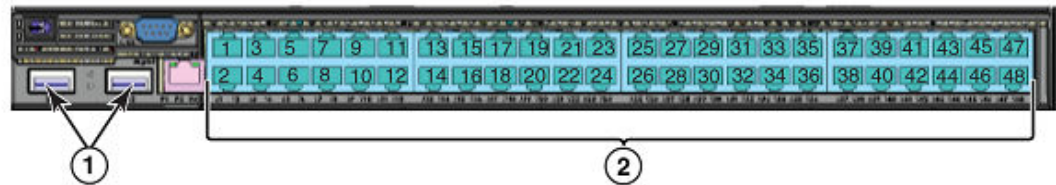

-
- 1 10 GbE XFP ports
-
- 2 Forty-eight 10/100/1000 MbE RJ45 ports
-

Brocade NetIron CES Series 2048F

Brocade NetIron CES Series 2048F (Fiber) has forty-eight 100/1000 MbE SFP ports, one DB9 serial management interface port labeled Console, one 10/100/1000 MbE RJ45 out-of-band management port, one resilient six-unit fan tray, and two AC power supply bays for 1+1 redundancy with one 500W AC power supply included.

FIGURE 25 Brocade NetIron CES Series 2048F device

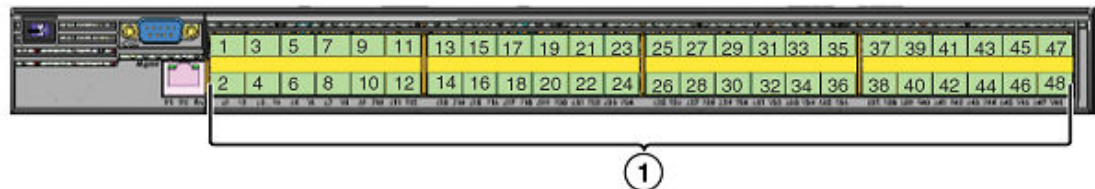

-
- 1 Forty eight 100/1000 MbE SFP ports
-

Brocade NetIron CES Series 2048FX

Brocade NetIron CES Series 2048FX (Fiber) switch has forty-eight 100/1000 MbE SFP ports plus two 10 GbE XFP ports, one DB9 serial management interface port labeled Console, one 10/100/1000 MbE RJ45 out-of-band management port, one resilient six-unit fan tray, and two AC power supply bays for 1+1 redundancy with one 500W AC power supply included.

FIGURE 26 Brocade NetIron CES Series 2048FX device

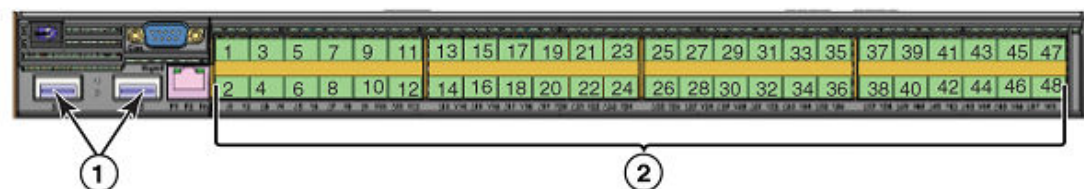

1	10 GbE XFP ports
---	------------------

2	Forty eight 100/1000 MbE SFP ports
---	------------------------------------

Brocade NetIron CER Series 2024C

The Brocade NetIron CER Series 2024C router has twenty-four 10/100/1000 MbE RJ45 ports plus four combination 100/ 1000 MbE SFP ports, one module slot for an optional field upgradable 2-port 10 GbE XFP module, one DB9 serial management interface port labeled Console, one 10/100/1000 MbE RJ45 out-of-band management port, one resilient six-unit fan tray, and two AC power supply bays for 1+1 redundancy with one 500W AC power supply included.

The Brocade NetIron CER Series-RT 2024C router has more memory to support 1.5M routes, twenty-four 10/100/1000 MbE RJ45 ports plus four combination 100/ 1000 MbE SFP ports, one module slot for an optional field upgradable 2-port 10 GbE XFP module, one DB9 serial management interface port labeled Console, one 10/100/1000 MbE RJ45 out-of-band management port, one resilient six-unit fan tray, and two AC power supply bays for 1+1 redundancy with one 500W AC power supply included.

FIGURE 27 Brocade NetIron CER Series 2024C device with the optional 2 ports of 10-G XFP uplink

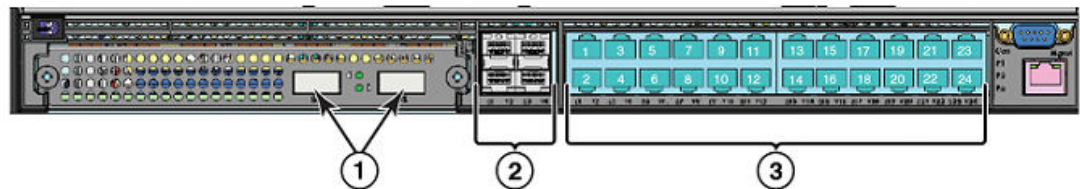

1	Optional 10 GbE XFP ports
---	---------------------------

2	Four combination 100/1000 MbE SFP ports
---	---

3	Twenty-four 10/100/1000 MbE RJ45 ports
---	--

Brocade NetIron CER Series 2024F

The Brocade NetIron CER Series 2024F has twenty-four 100/1000 MbE SFP ports plus four combination 10/100/1000 MbE RJ45 ports, one module slot for an optional field upgradable 2-port 10 GbE XFP module, one DB9 serial management interface port labeled Console, one 10/100/1000 MbE RJ45 out-of-band management port, one resilient six-unit fan tray, and two AC power supply bays for 1+1 redundancy with one 500W AC power supply included.

The Brocade NetIron CER Series-RT 2024F has more memory to support 1.5M routes, twenty-four 100/1000 MbE SFP ports plus four combination 10/100/1000 MbE RJ45 ports, one module slot for an optional field upgradable 2-port 10 GbE XFP module, one DB9 serial management interface port labeled Console, one 10/100/1000 MbE RJ45 out-of-band management port, one resilient six-unit fan tray, and two AC power supply bays for 1+1 redundancy with one 500W AC power supply included.

FIGURE 28 Brocade NetIron CER Series 2024F device

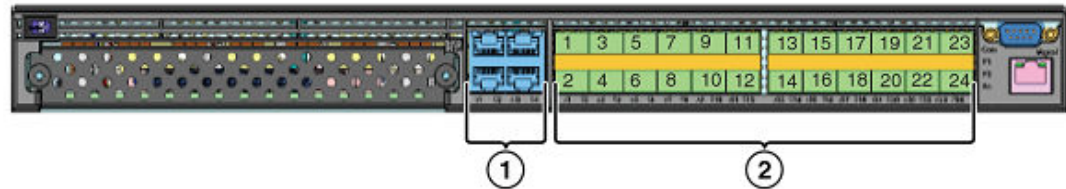

-
- 1 Four combination 10/100/1000 MbE RJ45 ports with support for optional 10Gbe XFP ports
-
- 2 Twenty-four 100/1000 MbE SFP ports.
-

Brocade NetIron CER Series 2048C

Brocade NetIron CER Series 2048C (Copper) router has forty-eight 10/100/1000 MbE RJ45 ports plus four combination 100/ 1000 MbE SFP ports, one DB9 serial management interface port labeled Console, one 10/100/1000 MbE RJ45 out-of-band management port, one resilient six-unit fan tray, and two AC power supply bays for 1+1 redundancy with one 500W AC power supply included.

Brocade NetIron CER Series-RT 2048C (Copper) router has more memory to support 1.5M routes, forty-eight 10/100/1000 MbE RJ45 ports plus four combination 100/ 1000 MbE SFP ports, one DB9 serial management interface port labeled Console, one 10/100/1000 MbE RJ45 out-of-band management port, one resilient six-unit fan tray, and two AC power supply bays for 1+1 redundancy with one 500W AC power supply included.

FIGURE 29 Brocade NetIron CER Series 2048C device

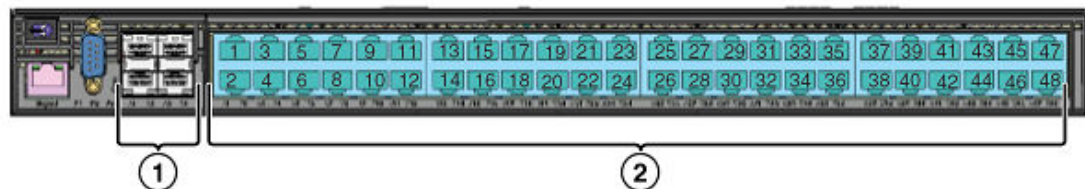

-
- 1 Four combination 100/1000 MbE SFP ports
-
- 2 Forty-eight 10/100/1000 MbE RJ45 ports
-

Brocade NetIron CER Series 2048CX

Brocade NetIron CER Series 2048CX (Copper) has forty-eight 10/100/1000 MbE RJ45 ports plus two 10 GbE XFP ports, one DB9 serial management interface port labeled Console, one 10/100/1000 MbE RJ45 out-of-band management port, one resilient six-unit fan tray, and two AC power supply bays for 1+1 redundancy with one 500W AC power supply included.

Brocade NetIron CER Series-RT 2048CX (Copper) has more memory to support 1.5M routes, forty-eight 10/100/1000 MbE RJ45 ports plus two 10 GbE XFP ports, one DB9 serial management interface

port labeled Console, one 10/100/1000 MbE RJ45 out-of-band management port, one resilient six-unit fan tray, and two AC power supply bays for 1+1 redundancy with one 500W AC power supply included.

FIGURE 30 Brocade NetIron CER Series 2048CX device

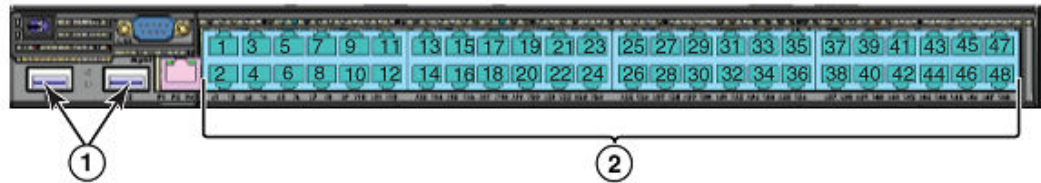

-
- 1 10 GbE XFP ports
-
- 2 Forty-eight 10/100/1000 MbE RJ45 ports
-

Brocade NetIron CER Series 2048F

Brocade NetIron CER Series 2048F (Fiber) has forty-eight 100/1000 MbE SFP ports, one DB9 serial management interface port labeled Console, one 10/100/1000 MbE RJ45 out-of-band management port, one resilient six-unit fan tray, and two AC power supply bays for 1+1 redundancy with one 500W AC power supply included.

Brocade NetIron CER Series-RT 2048F (Fiber) has more memory to support 1.5M routes, forty-eight 100/1000 MbE SFP ports, one DB9 serial management interface port labeled Console, one 10/100/1000 MbE RJ45 out-of-band management port, one resilient six-unit fan tray, and two AC power supply bays for 1+1 redundancy with one 500W AC power supply included.

FIGURE 31 Brocade NetIron CER Series 2048F device

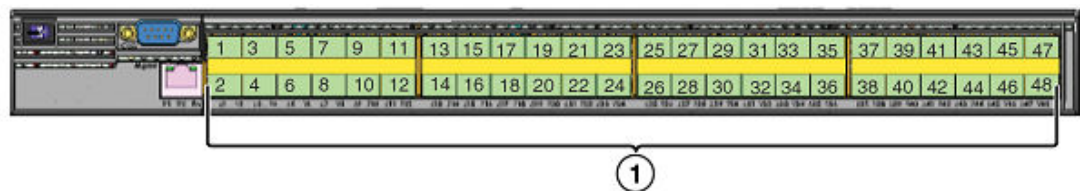

-
- 1 Forty eight 100/1000 MbE SFP ports
-

Brocade NetIron CER Series 2048FX

Brocade NetIron CER Series 2048FX (Fiber) router has forty-eight 100/1000 MbE SFP ports plus two 10 GbE XFP ports, one DB9 serial management interface port labeled Console, one 10/100/1000 MbE RJ45 out-of-band management port, one resilient six-unit fan tray, and two AC power supply bays for 1+1 redundancy with one 500W AC power supply included.

Brocade NetIron CER Series-RT 2048FX (Fiber) router has more memory to support to support 1.5M routes, forty-eight 100/1000 MbE SFP ports plus two 10 GbE XFP ports, one DB9 serial management interface port labeled Console, one 10/100/1000 MbE RJ45 out-of-band management port, one

resilient six-unit fan tray, and two AC power supply bays for 1+1 redundancy with one 500W AC power supply included.

FIGURE 32 Brocade NetIron CER Series 2048FX device

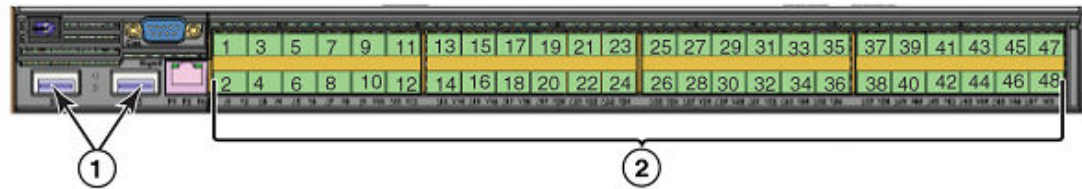

1	10 GbE XFP ports
2	Forty eight 100/1000 MbE SFP ports

Control features

The front panel on each device has a combination of the following control features:

- Serial Management Interface (the port labeled Console)
- 10/100/1000 ports with RJ-45 copper connectors
- 100/1000 Hybrid Fiber (HF) ports
- 100/1000 ports with mini-GBIC slots for SFP MSA-compliant fiber transceivers
- Each device that optionally has up to two 10-Gigabit Ethernet uplink ports, supports 10-Gigabit Small Form Factor Pluggable (XFP) MSA-compliant optical transceivers
- Each device that has four 10-Gigabit Ethernet uplink ports, supports 10-Gigabit Small Form Factor Pluggable (SFP+) MSA-compliant optical transceivers

Serial Management Interface (console port)

The Serial Management Interface enables you to configure and manage the device using a third-party terminal emulation application on a directly connected PC. A straight-through EIA/TIA DB-9 serial cable (M/F) ships with the device. The serial management interface (the port labeled Console) is located in the front panel.

Port LEDs

The ports on the devices provide status information using the LEDs listed in [Table 3](#) and [Table 4](#).

TABLE 3 LEDs for 10/100/1000 Mbps ports

LED	Position	State	Meaning
10/100/1000 Port LEDs			
Lnk/Act	Bottom Left	On	Link is up.
		Off	Link is down.

TABLE 3 LEDs for 10/100/1000 Mbps ports (Continued)

LED	Position	State	Meaning
		Blinking	Port is transmitting or receiving traffic
Lnk/Act	Bottom Right	On	Link is up.
		Off	Link is down.
		Blinking	Port is transmitting or receiving traffic

NOTE

The LEDs are located beneath the port connector.

TABLE 4 LEDs for 10-Gbps Ethernet ports

LED	Port	State	Meaning
10-Gbps Port LEDs on devices with two 10-Gbps ports			
Top	Left hand port	On	The port is connected.
		Off	No fiber port connection exists.
		Blinking	Traffic is being transmitted and received on the fiber port
Bottom	Right hand port	On	The port is connected.
		Off	No fiber port connection exists.
		Blinking	Traffic is being transmitted and received on the fiber port
10-Gbps Port LEDs on devices with four 10-Gbps ports			
Top	Left hand port	On	The port is connected.
		Off	No fiber port connection exists.
		Blinking	Traffic is being transmitted and received on the fiber port
Bottom	Right hand port	On	The port is connected.
		Off	No fiber port connection exists.
		Blinking	Traffic is being transmitted and received on the fiber port

NOTE

The LEDs are located adjacent to the port connector.

Network interfaces

This section describes the port types in the Brocade NetIron CES Series, Brocade NetIron CER Series 2000 series devices.

10/100/1000 Mbps ports

The 10/100/1000 ports on the device use auto-sensing and auto-negotiating to determine the speed (10 Mbps, 100 Mbps, or 1000 Mbps) and duplex mode (full-duplex or half-duplex) of the port at the other end of the link and adjust port speed accordingly.

Combination ports

On devices with combination (combo) ports, one port out of each pair of copper and fiber ports can be active at a time. Combo ports are numbered 1-4. For example, you can use either copper port 2 or fiber port 2, but not both at the same time. You can use a combination of fiber and copper ports or all copper or all fiber ports, as needed.

If you attach both the copper and fiber connectors for a port to the network, the fiber connectors take precedence over the copper connectors. These ports support true media automatic detection, meaning the device selects the fiber or copper connector based on link availability. If a fiber link cannot be established, the device selects the copper media.

10-Gbps ports

The Brocade NetIron CES Series 2048C-4X, Brocade NetIron CES Series 2048F-4X, Brocade NetIron CER Series 2048C-4X-RT, and the Brocade NetIron CER Series 2048F-4X-RT come with four 10-Gigabit Ethernet ports installed. The four 10-Gigabit Ethernet uplink ports support 10-Gigabit Small Form Factor Pluggable (SFP+) MSA-compliant optical transceivers

The Brocade NetIron CES Series 2048CX, Brocade NetIron CES Series 2048FX, Brocade NetIron CER Series 2048CX, and the Brocade NetIron CER Series 2048FX come with two 10-Gigabit Ethernet ports installed. A 24-port Brocade NetIron CES Series, Brocade NetIron CER Series has a slot to accommodate a 2-port 10-Gigabit Ethernet module. If your 24-port device does not include a 10-GbE module, you can optionally install one. Refer to [10-Gbps ports](#). The two 10-Gigabit Ethernet ports use 10-Gigabit Small Form Factor Pluggable (XFP) MSA-compliant transceivers.

Supported optics

100/1000 Ethernet Ports

The Ethernet Interface module contains 24 or 48 physical ports, through which you can connect your device to other network devices at a speed of 100 Mbps or 1 Gbps.

Into a physical port, you must insert a fiber-optic transceiver provided by Brocade. The SFP-compliant fiber-optic modules provide an optical transceiver or physical medium-dependent (PMD) interface for fiber that can be used with the LAN physical layer (PHY)

The following 100 Mbps and 1 GbE optical transceivers are available from Brocade:

TABLE 5 SFP-compliant transceivers for the 100/1000 Ethernet interface module

Part number	Description
E1MG-TX	SFP Copper, RJ-45 connector
E1MG-SX	1000Base-SX SFP optic, multi-mode fiber, LC connector
E1MTG-SX	1000Base-SX SFP optic, multi-mode fiber, MTRJ connector
E1MG-SX2-1310	1310 1000Base-SX SFP optic multi-mode fiber, LC connector and support for distances up to 2km
E1MG-LX	1000Base-LX SFP optic, single-mode fiber, LC connector
E1MG-LHA	1000Base-LHA SFP optic, single-mode fiber, LC connector
E1MG-LHB	1000Base-LHB SFP optic, single-mode fiber, LC connector, 150km Maximum Reach
E1MG-BXD	1000Base-BXD SFP optic single-mode fiber, 1490nm, LC connector. This optic can only be connected to an E1MG-BXU
E1MG-CWDM80-1470	CWDM SFP optic, 80km, 1470nm, LC connector
E1MG-CWDM80-1490	CWDM SFP optic, 80Km, 1490nm, LC connector
E1MG-CWDM80-1510	CWDM SFP optic, 80Km, 1510nm, LC connector
E1MG-CWDM80-1530	CWDM SFP optic, 80Km, 1530nm, LC connector
E1MG-CWDM80-1550	CWDM SFP optic, 80Km, 1550nm, LC connector
E1MG-CWDM80-1570	CWDM SFP optic, 80Km, 1570nm, LC connector
E1MG-CWDM80-1590	CWDM SFP optic, 80Km, 1590nm, LC connector
E1MG-CWDM80-1610	CWDM SFP optic, 80Km, 1610nm, LC connector
E1MG-100FX	100Base-FX SFP optic multi-mode fiber, LC connector
E1MG-100FX-IR	100BaseFX-IR optic for SMF with LC connector. For distances up to 15nm.
E1MG-100FX-LR	100BaseFX-LR SFP optic for SMF with LC connector. For distances up to 40km.

10 Gigabit Ethernet ports

A 10 Gigabit Ethernet module contains two or four physical ports, through which you can connect your device to other network devices at a speed of 10 Gigabits.

Into a physical port, you must insert a fiber-optic transceiver provided by device. The XFP/SFP+-compliant fiber-optic modules provide an optical transceiver or physical medium-dependent (PMD) interface for single or multi-mode fiber that can be used with the LAN physical layer (PHY).

The following 10 Gigabit optics are available from device.

TABLE 6 MSA-compliant Optics for the 10 GbE Ethernet interface module

Part number	Description
Devices with up to two 10GbE ports (XFP)	
10G-XFP-SR	850nm serial pluggable XFP optic, target range 300m over multi-mode fiber
10G-XFP-LR	1310nm serial pluggable XFP optic for up to 10km over single-mode fiber
10G-XFP-ER	1550nm serial pluggable XFP optic for up to 40km over single-mode fiber
10G-XFP-ZR	1550nm serial pluggable XFP optic for up to 80km over single-mode fiber
10G-XFP-ZRD	10GBase-ZR DWDM, XFP optic, 80km, 1530.33 to 1561.42
10G-XFP-CX4	10-Base-CX4, XFP transceiver, 15km, CX connector
Devices with up to four 10GbE ports (SFP+)	
10G-SFPlus-SR	
10G-SFPlus-LR	
10G-SFPlus-ZR	
10G-SFPlus-ZRD	

Port regions

Ports on the devices are grouped into regions. For a few features, such as port monitoring and unknown unicast configurations, you will need to know the region to which a port belongs. However, for most features, a port's region does not affect configuration or operation of the feature. If a port's region does affect configuration or operation of a feature, it is noted and described in the appropriate feature section of this guide.

Brocade NetIron CES Series 2024 and CER 2024 devices with 24 ports have 2 optional 10-GbE ports:

- Ports 1/1 - 1/24
- Port 2/1 (optional 10-GbE uplink port)
- Port 2/2 (optional 10-GbE uplink port)
- Port 2/3 (optional 10-GbE uplink port)
- Port 2/4 (optional 10-GbE uplink port)

Brocade NetIron CES Series 2048 and Brocade NetIron CER Series 2048 devices with 48 ports:

- Ports 1/1 -1/24
- Ports 1/25 - 1/48
- Port 2/1 (10-GbE uplink port on Brocade NetIron CES Series 2048CX, Brocade NetIron CES Series 2048FX, Brocade NetIron CER Series 2048CX, and Brocade NetIron CER Series 2048FX models only)
- Port 2/2 (10-GbE uplink port on Brocade NetIron CES Series 2048CX, Brocade NetIron CES Series 2048FX, Brocade NetIron CER Series 2048CX, and Brocade NetIron CER Series 2048FX models only)

- Port 2/3 (10-GbE uplink port on Brocade NetIron CES Series 2048CX, Brocade NetIron CES Series 2048FX, Brocade NetIron CER Series 2048CX, and Brocade NetIron CER Series 2048FX models only)
- Port 2/4 (10-GbE uplink port on Brocade NetIron CES Series 2048CX, Brocade NetIron CES Series 2048FX, Brocade NetIron CER Series 2048CX, and Brocade NetIron CER Series 2048FX models only)

Brocade NetIron CES Series 2024x and Brocade NetIron CER Series 2024x devices with 24 ports have 2 optional 10-G ports:

- Ports 1/1 -1/24
- Port 2/1 (10G uplink port)
- Port 2/2 (10G uplink port)
- Port 2/3 (10G uplink port)
- Port 2/4 (10G uplink port)

Network interfaces

The output of the **show media** command displays the type of media installed in the ports.

```
device# show media
Port 1/1:
  Type : Copper
  Vendor: Unknown, Version: Unknown
  Part# : Unknown, Serial#: Unknown
Port 1/2:
  Type : Copper
  Vendor: Unknown, Version: Unknown
  Part# : Unknown, Serial#: Unknown
Port 1/24:
  Type : Copper
  Vendor: , Version: Unknown
  Part# : Unknown, Serial#: Unknown
Port 2/1:
  Type : 10GBASE-SR/SW (XFP)
  Vendor: FOUNDRY NETWORKS, Version: 00
  Part# : FTLX8511D3-F1 , Serial#: KCP02X8
Port 2/2:
  Type : 10GBASE-SR/SW (XFP)
  Vendor: FOUNDRY NETWORKS, Version: 02
  Part# : TRF2000EN-LF251 , Serial#: T07J23170
All show media done
```

Syntax: show media

Power supplies

Each device comes with one alternating-current (AC) or one direct-current (DC) power supply. All models have two power supply slots, enabling you to install a second power supply for redundancy.

NOTE

Changes or modifications made to this device that are not expressly approved by the party responsible for compliance could void the user's authority to operate the equipment.

The power supplies can be swapped in or out of the device while the device is running. You can remove and insert a power supply without opening the chassis. The remaining supply provides enough power for the entire system.

The following sections provide further details about the power supplies for the devices:

- Power status LEDs are listed in [Power supplies](#).
- Hardware specifications for the power supplies are listed in [Power supplies](#).
- Redundant power supplies and power supply failure information is listed in [About redundant power supplies and power supply failure](#) on page 36.

AC power supplies

[AC power supplies](#) shows a rear view of a device containing one AC power supply.

FIGURE 33 AC Power Supply

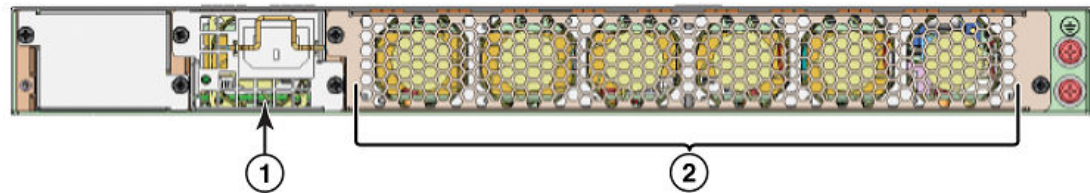

1	Power supply
2	Six cooling fans

DC power supplies

The DC power supply is shown in the diagram [DC power supplies](#).

FIGURE 34 DC Power Supply

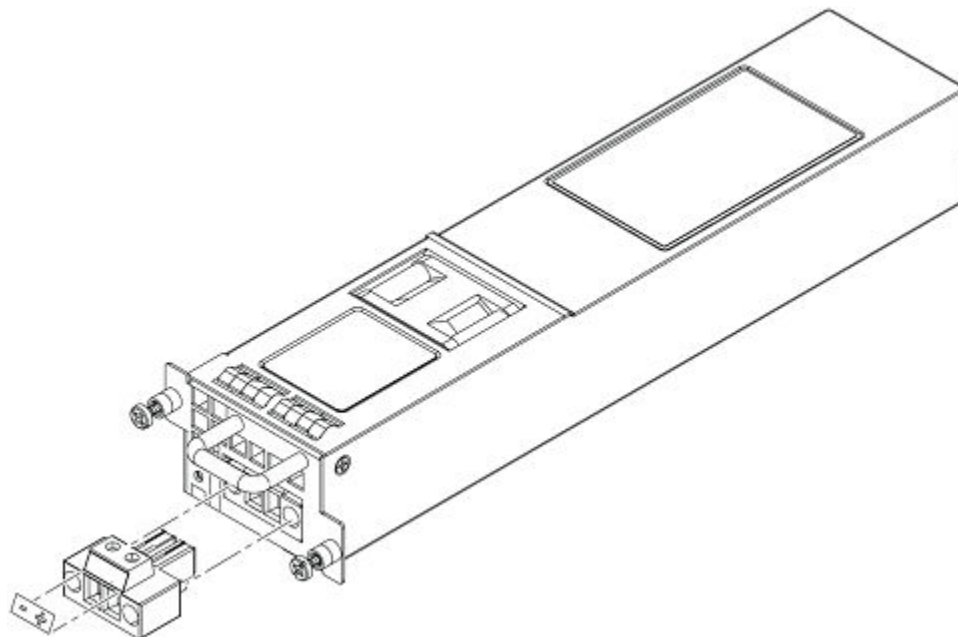

About redundant power supplies and power supply failure

A device with redundant power supplies can maintain full operation when one power supply fails. Power supply failure can be a failure of the supply itself or the power grid connected to the power supply.

Cooling system and fans

This section describes the fans in the devices with 6 fans.

[Cooling system and fans](#) shows the cooling fans.

FIGURE 35 Cooling Fans

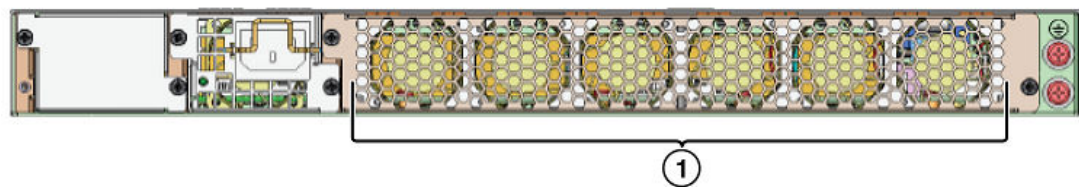

1 Six cooling fans

The device cooling fans use pull configuration to move the air from the front to the back of the device.

NOTE

Brocade Netron CES/CER-4X-RT supports the XNI-CE-2000-FAN pre-installed or as a spare. All other models support the NI-CE-2000-FAN.

The fans in the devices include six four-speed fans that operate at low speed, medium speed, medium-high speed, and high speed based on the ambient temperature and configured or default temperature thresholds. All fans operate simultaneously at the same speed. If a single fan fails within the assembly, the fan tray should be replaced. The fan tray is hot swappable and the mean time to recover (MTTR) is one minute.

The system uses a default or configured temperature threshold associated with it to determine at which speed the fan should operate.

Connecting to a Network Device

- Password assignment..... 37
- IP address configuration..... 38
- Management port function overview..... 41
- Device connection..... 41

Password assignment



DANGER

The procedures in this manual are for qualified service personnel.

By default, the device's CLI is not protected by passwords. To secure CLI access, Brocade strongly recommends assigning passwords.

The CLI contains the following access levels:

- Privileged EXEC - This level is also called the Enable level and can be secured by a password. You can perform tasks such as manage files on the management module's flash memory or a PCMCIA flash card in the management module's slots 1 or 2, save the system configuration to flash memory, and clear caches at this level.
- CONFIG - The configuration level. This level lets you configure the system's IP address and configure routing features. To access the CONFIG mode, you must already be logged into the Privileged level of the EXEC mode.

NOTE

You can assign passwords using the Brocade Network Advisor if an Enable password for a Super User is already configured on the device.

You can set the following levels of Enable passwords:

- Super User - Allows complete read-and-write access to the system. This is generally for system administrators and is the only password level that allows you to configure passwords.

NOTE

You must set a super user password before you can set other types of passwords.

- Port Configuration - Allows read-and-write access for specific ports but not for global (system-wide) parameters.
- Read Only - Allows access to the Privileged EXEC mode and CONFIG mode but only with read access.

Follow the steps given below to set passwords.

1. At the opening CLI prompt, enter the following command to change to the Privileged level of the EXEC mode.

```
device> enable
device#
```

2. Access the CONFIG level of the CLI by entering the following command.

```
device# configure terminal
device(config)#
```

3. Enter the following command to set the super-user password.

```
device(config)#
    enable super-user-password <text>
```

NOTE

You must set the super-user password before you can set other types of passwords.

4. Enter the following commands to set the port configuration and read-only passwords.

```
device(config)#          enable port-config-password <text>
device(config)#          enable read-only-password <text>
```

NOTE

If you forget your super-user password, see the Release Notes.

Syntax: enable super-user-password | read-only-password | port-config-password *text*

Passwords can be up to 48 characters long.

IP address configuration

The devices implement separate data and control planes. This architecture affects how you assign IP addresses. [Table 7](#) outlines the interfaces to which you can assign IP addresses.

In this table, "in band" refers to an interface over which user packets are routed, while "out of band" refers to an interface over which control packets related to system management are forwarded.

TABLE 7 Assigning IP addresses

Interface	Associated physical port	Out of band/In band
Management interface	Ethernet 10/100/1000 port on active management module	Out of band
Any interface over which user packets are routed	Any interface module port	In band
Any virtual interface over which user packets are routed	Any interface port	In band
Loopback interface	-	In band

This section describes the following:

- Support of sub-net masks
- How to assign an IP address to a management interface
- How to assign an IP address to an interface or virtual interface over which user packets are routed

Support of sub-net masks

The devices support both classical IP network masks (Class A, B, and C sub-net masks, and so on) and Classless Interdomain Routing (CIDR) network prefix masks.

The following sub-net masks are supported by the devices:

- To enter a classical network mask, enter the mask in IP address format. For example, enter "209.157.22.99 255.255.255.0" for an IP address with a Class-C sub-net mask.
- To enter a prefix number for a network mask, enter a forward slash (/) and the number of bits in the mask immediately after the IP address. For example, enter "209.157.22.99/24" for an IP address that has a network mask with 24 significant ("mask") bits.

Assigning an IP address to a management interface

Instead of assigning a global IP address to the device for system management purposes, you now assign an IP address to the management interface. The IP address is assigned to the active management module port. If the active management module becomes unavailable and the redundant module becomes the active module, the IP address is assigned to the new active management module port.

For example, to assign the IP address 10.0.1.1 to the management interface, do the following.

1. At the opening CLI prompt, enter enable.

```
device> enable
```

2. Enter the following command at the Privileged EXEC level prompt (for example, **Brocade#**), then press Enter. This command erases the factory test configuration if still present.

```
device# erase startup-config
```



CAUTION

Use the erase startup-config command only for new systems. If you enter this command on a system you have already configured, the command erases the configuration. If you accidentally do erase the configuration on a configured system, enter the write memory command to save the running configuration to the startup-config file.

3. Access the configuration level of the CLI by entering the following command.

```
device# configure terminal
device(config)#
```

4. Configure the IP address and mask for the management interface by entering the following commands.

```
device(config)# interface management 1
device(config-if-mgmt-1)# ip address 10.0.1.1 255.255.255.0
```

Syntax: enable [*password*]

Syntax: configure terminal

Syntax: interface management 1

Syntax: [no] ip address ip-addr:ip-mask

or

Syntax: [no] ip address *ip-addr/mask-bits*

Assigning an IP address to an interface, virtual interface, or loopback

As you have done with other devices, you must assign an IP address to each interface and virtual interface over which user packets are routed. You can also assign an IP address to a loopback interface, which is generally used for testing and diagnostic purposes.

You must use the serial connection to assign the first IP address. For subsequent addresses, you also can use the CLI through Telnet. You can use Brocade Network Advisor to assign IP addresses to virtual routing interfaces only.

By default, you can configure up to 24 IP interfaces on each interface, virtual interface, and loopback interface.

For example, to assign the IP address 192.22.3.44 and sub-net mask 255.255.255.0 to Ethernet interface 1/1, do the following.

1. At the opening CLI prompt, enter enable.

```
device> enable
```

2. Enter the following command at the Privileged EXEC level prompt, then press Enter. This command erases the factory test configuration if still present.

```
device# erase startup-config
```



CAUTION

Use the erase startup-config command only for new systems. If you enter this command on a system you have already configured, the command erases the configuration. If you accidentally do erase the configuration on a configured system, enter the write memory command to save the running configuration to the startup-config file.

3. Access the configuration level of the CLI by entering the following command.

```
device# configure terminal  
device(config)#
```

4. Configure the IP address and sub-net mask for Ethernet interface 1/1 by entering the following commands.

```
device(config)# interface ethernet 1/1  
device(config-if-e10000-1/1)# ip address 192.22.3.44 255.255.255.0
```

Syntax: enable [*password*]

Syntax: configure terminal

Syntax: [no] ip address *ip-addr/mask* [**secondary**]

or

Syntax: [no] ip address *ip-addr/mask-bits* [**secondary**]

Use the secondary parameter if you have already configured an IP address within the same sub-net on the interface.

Enabling and disabling the interfaces

By default, all interfaces are disabled. To enable an interface, you must enter the **enable** command at the appropriate interface configuration level of the CLI. For example, to enable the management interface, enter the **enable** command at the management interface configuration level of the CLI.

```
device(config-if-mgmt-1)# enable
```

Syntax: enable

You can disable each of these interfaces using the **disable** command at the appropriate interface configuration level of the CLI. For example, to disable the management port, enter the **disable** command at the management interface configuration level of the CLI.

```
device(config-if-mgmt-1)# disable
```

Syntax: disable

NOTE

For security reasons, by default, the telnet server is disabled on the devices. To enable the telnet server and allow access through telnet to the device from an external host, execute the

```
following.device(config)# telnet server
```

Management port function overview

You must be aware of how the system's management port functions as described in the following:

- The management port allows you to configure, monitor, and manage the system only. As a result, this port has the same limited functionality as an IP host port.
- You cannot enable and run routing protocols on the management port.
- The management port supports static routes and directly connected routes, which are installed in the management module's routing table. However, these routes are not installed in the interface module's routing table. Therefore, the interface modules are not aware of the management port's static or directly connected routes.
- If you configure the redistribution of directly connected or static routes for a particular routing protocol, the routing protocol will redistribute directly connected or static routes associated with the interface module ports but not those associated with the management port.

To display configuration information and statistics about the management port, you can enter the **show interface management 1** command at any CLI level.

Device connection

You can connect a Brocade device to another Ethernet network device. The Brocade devices support connections to other vendors' as well as Brocade network devices.

To connect a Brocade device to another network device, you must do the following:

- Install the fiber-optic modules if required
- Cable the modules with either copper cable or fiber optic cable as required

Connecting to a Network Device

For information on installing fiber-optic modules see [Device connection](#).

For information on cabling a fiber-optic module, see [Device connection](#).

For information on cleaning a fiber-optic module, see [Device connection](#).

Installation

- System unpacking..... 43
- Summary of installation tasks..... 44
- Installation precautions..... 45
- Installation site preparation..... 47
- Redundant power supply installation..... 48
- Device installation..... 53
- System power..... 57
- Operation verification..... 58
- PC or terminal attachment..... 61

System unpacking



DANGER

The procedures in this manual are for qualified service personnel.

The Brocade systems ship with all of the following items. Please review the list below and verify the contents. If any items are missing, please contact the place of purchase.

Package contents

The package contains the following:

- Brocade NetIron CES Series 2000 or Brocade NetIron CER Series 2000 series device
- 115V AC power cable (for AC sourced devices)

General requirements

To manage the system, you need the following items for serial connection to the router:

- A management station, such as a PC running a terminal emulation application.
- A straight-through EIA/TIA DB-9 serial cable (F/F). The serial cable can be ordered separately from Brocade. If you prefer to build your own cable, refer to the pinout information in [General requirements](#).

You use the serial connection to perform basic configuration tasks including assigning an IP address and network mask to the system. This information is required for managing the system using Brocade Network Advisor or using the CLI through Telnet.



CAUTION

To prevent damage to the chassis and components, never attempt to lift the chassis using the fan or power supply handles. These handles were not designed to support the weight of the chassis.

**CAUTION**

Before plugging a cable into to any port, be sure to discharge the voltage stored on the cable by touching the electrical contacts to ground surface.

Summary of installation tasks

Follow the steps listed below to install your Brocade device. Details for each of the steps highlighted below are provided in this chapter and in the following chapter.

TABLE 8 Summary of installation tasks

Task number	Task	Where to find more information
1	Ensure that the physical environment that will host the device has the proper cabling and ventilation.	Installation site preparation on page 47
2	Optionally insert a second or redundant power supply. If you need to install a power supply, it may be easier to install it before mounting the device, although the power supplies are "hot swappable", and can be installed or removed after the device is mounted and powered-on.	Redundant power supply installation on page 48
3	Install the Brocade device in an equipment rack.	Device installation on page 53
4	Once the device is physically installed, plug the device into a nearby power source that adheres to the regulatory requirements outlined in this manual.	System power on page 57
5	Verify that the system LEDs are registering the proper LED state after power-on of the system.	Operation verification on page 58
6	Attach a terminal or PC to the device. This will enable you to configure the device through the Command Line Interface (CLI).	PC or terminal attachment on page 61
7	No default password is assigned to the CLI. For additional access security, assign a password.	Summary of installation tasks
8	Before connecting to the device, you need to configure an interface IP address to the subnet on which it will be located. Initial IP address configuration is performed using the CLI with a direct serial connection. Subsequent IP address configuration can be performed using the command line interface.	Summary of installation tasks
9	Once you power on the device and assign IP addresses, the system is ready to accept network connections.	Summary of installation tasks
10	Secure access to the device.	Multi-Service IronWare Security Guide

Installation precautions

Follow these precautions when installing the unit.



DANGER

Risk of explosion if battery is replaced by an incorrect type. Dispose of used batteries according to the instructions.



DANGER

All fiber-optic interfaces use Class 1 lasers.



CAUTION

Do not install the device in an environment where the operating ambient temperature might exceed 40°C (104°F).



CAUTION

Make sure the airflow around the front, sides, and back of the device is not restricted.



CAUTION

Never leave tools inside the chassis.

Lifting precautions



DANGER

Make sure the rack housing the device is adequately secured to prevent it from becoming unstable or falling over.



DANGER

Mount the devices you install in a rack as low as possible. Place the heaviest device at the bottom and progressively place lighter devices above.



CAUTION

To prevent damage to the chassis and components, never attempt to lift the chassis using the fan or power supply handles. These handles were not designed to support the weight of the chassis.

Power precautions



CAUTION

Use a separate branch circuit for each power cord, which provides redundancy in case one of the circuits fails.



CAUTION

Ensure that the device does not overload the power circuits, wiring, and over-current protection. To determine the possibility of overloading the supply circuits, add the ampere (amp) ratings of all devices installed on the same circuit as the device. Compare this total with the rating limit for the circuit. The maximum ampere ratings are usually printed on the devices near the input power connectors.



CAUTION

Carefully follow the mechanical guides on each side of the power supply slot and make sure the power supply is properly inserted in the guides. Never insert the power supply upside down.

NOTE

Power supplies are hot swappable.



CAUTION

Remove the power cord from a power supply before you install it in or remove it from the device. Otherwise, the power supply or the device could be damaged as a result. (The device can be running while a power supply is being installed or removed, but the power supply itself should not be connected to a power source.)



CAUTION

The power supply is designed exclusively for use with the Brocade NetIron CES Series and Brocade NetIron CER Series devices. The power supply produces extensive power. Installing the power supply in a device other than a NetIron CES Series or NetIron CER Series will cause damage to your equipment.



DANGER

Disconnect the power cord from all power sources to completely remove power from the device.



DANGER

Make sure to choose the appropriate circuit device depending on the number of AC power supplies installed in the chassis. The minimum current draw for the system is one AC power supply.



DANGER

Make sure that the power source circuits are properly grounded, then use the power cord supplied with the device to connect it to the power source.



DANGER

If the installation requires a different power cord than the one supplied with the device, make sure you use a power cord displaying the mark of the safety agency that defines the regulations for power cords in your country. The mark is your assurance that the power cord can be used safely with the device.

**CAUTION**

All devices with DC power supplies are intended for installation in restricted access areas only. A restricted access area is where access can be gained only by service personnel through the use of a special tool, lock and key, or other means of security, and is controlled by the authority responsible for the location.

**CAUTION**

For the DC input circuit, (DC power supply part number RPS9-DC), make sure there is a 20-amp circuit breaker, minimum -48VDC, double pole, on the input to the terminal block. The input wiring for connection to the product should be copper wire, 12 AWG, marked VW-1, and rated 90 degrees Celsius.

**CAUTION**

For a DC system, use a grounding wire of at least 6 American Wire Gauge (AWG). The 6 AWG wire should be attached to an agency-approved crimp connector crimped with the proper tool. The crimp connector should allow for securement to both ground screws on the enclosure. For the Ground lug, use UL listed Panduit crimp connector, P/N LCD6-10A, and two 10-32, PPH, screws to secure crimp connector to chassis. Grounding position is located on the side of the chassis adjacent ground symbol.

Installation site preparation

Cabling infrastructure

Ensure that the proper cabling is installed in the site. Refer to [Cabling infrastructure](#) or www.brocade.com for a summary of supported cabling types and their specifications.

**DANGER**

*The intra-building port or ports of the equipment or subassembly is suitable for connection to intra-building or unexposed wiring or cabling only. The intra-building port or ports of the equipment or subassembly **MUST NOT** be metallically connected to interfaces that connect to the outside plant (OSP) or its wiring. These interfaces are designed for use as intra-building interfaces only (Type 2 or Type 4 ports as described in GR-1089-CORE, Issue 5) and require isolation from the exposed OSP cabling. The addition of Primary Protectors is not sufficient protection in order to connect these interfaces metallically to OSP wiring.*

Installation location

Before installing the device, plan its location and orientation relative to other devices and equipment. Allow at least 3 in. of space at the front of the device for the twisted-pair, fiber-optic, and power cabling. Also, allow a minimum of 3 in. of space between the sides and the back of the device and walls or other obstructions.

A Brocade device is suitable for installation in Network Telecommunications facilities and locations where the NEC (National Electric Code) apply.

The device must be installed in a restricted access location, either a Central Office or customer-premises equipment location.

Redundant power supply installation

The Brocade device ships with one alternating-current (AC) power supply or direct-current (DC) power supply. All models have two power supply slots, enabling you to install a second power supply for redundancy. If desired, you can install a second supply for redundancy.



CAUTION

Changes or modifications made to this device that are not expressly approved by the party responsible for compliance could void the user's authority to operate the equipment.

If you need to install a redundant power supply, it may be easier to install it before mounting the device, although the power supplies are "hot swappable" and can be installed or removed after the device is mounted and powered on.

This section provides the following procedures:

- Installing a redundant AC power supply - [Installing an AC power supply](#) on page 48
- Installing a redundant DC power supply - [Installing a DC power supply](#) on page 50

Installing an AC power supply



DANGER

Before beginning the installation, see the precautions in "Power precautions."

FIGURE 36 Use the following procedures for AC power supplies in Brocade NetIron CES Series, Brocade NetIron CER Series 2000 series devices.

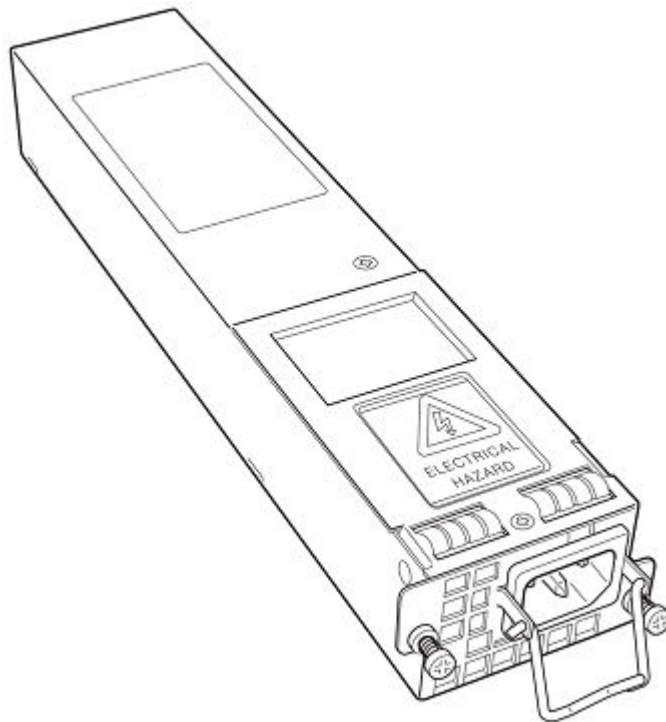

Follow the procedure given below to install an AC power supply.

1. If necessary, remove the power supply locking screws located in the upper left and the bottom right of the device (illustrated below).

FIGURE 37 Power supply installation

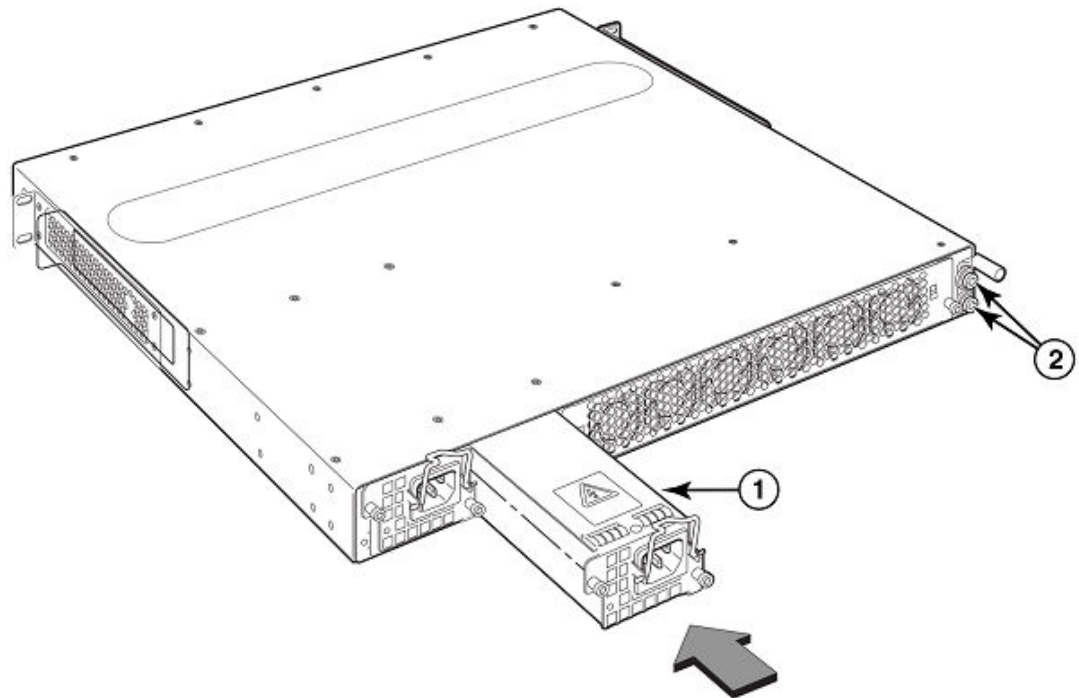

1	Power supply	2	Grounding terminals
---	--------------	---	---------------------

2. If the empty power supply bay has a cover plate, remove the two screws near the edges of the cover plate to unlock the plate, then remove the plate.
3. Remove the power supply from its packaging.
4. With one hand, hold the bar on the front panel of the power supply. With the other hand, support the underside of the power supply, and insert the power supply into the empty power supply slot. Press until the supply is completely in the slot, so that the connectors on the back of the supply are fully engaged with the pins on the power backplane.



CAUTION

Carefully follow the mechanical guides on each side of the power supply slot and make sure the power supply is properly inserted in the guides. Never insert the power supply upside down.

5. Secure the two screws near the edges of the supply to lock the supply in place.
6. Lift the AC cord retainer clip.
7. Connect the power cord to the power supply.
8. Snap the AC cord retainer clip over the power cord.
9. Connect the plug end of the power cord into outlet.



CAUTION

For a Brocade AC system, use a ground wire of at least 6 American Wire Gauge (AWG). The ground wire should have an agency-approved crimped connector (provided with the chassis) attached to one end, with the other end attached to building ground. The connector must be crimped with the proper tool, allowing it to be connected to both ground screws on the enclosure.

NOTE

To insure adequate bonding when attaching the provided Panduit LCD6-10AF two-hole ground lug, a minimum of 20 inch pounds of torque is required to be applied to the mounting hardware used to attach the ground lug. Use a star washer to ensure an NEBS compliant connection.

Installing a DC power supply



DANGER

Before beginning the installation, see the precautions in "Power precautions."

Use the following procedures for DC power supplies in Brocade NetIron CES Series, Brocade NetIron CER Series 2000 series devices.

Follow the steps given below to install an DC power supply.

1. If necessary, remove the power supply locking screws located in the upper left and the bottom right of the device.
2. If the empty power supply bay has a cover plate, remove the two screws near the edges of the cover plate to unlock the plate, then remove the plate.
3. Remove the DC power supply from its packaging ([Installing a DC power supply](#)).

FIGURE 38 The DC power supply

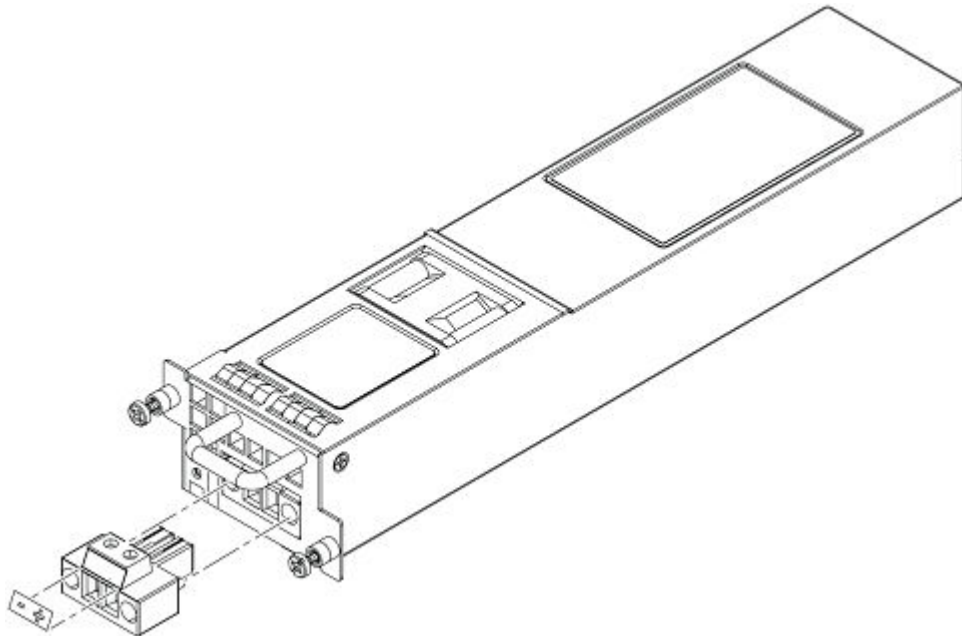

4. Insert the wires into the DC wiring assembly ([Installing a DC power supply](#)).

5. Use the wire tightening screws to secure the wires.
6. Insert the DC connector with wires to the power supply and tighten the two assembly screws.

FIGURE 39 The DC wiring assembly

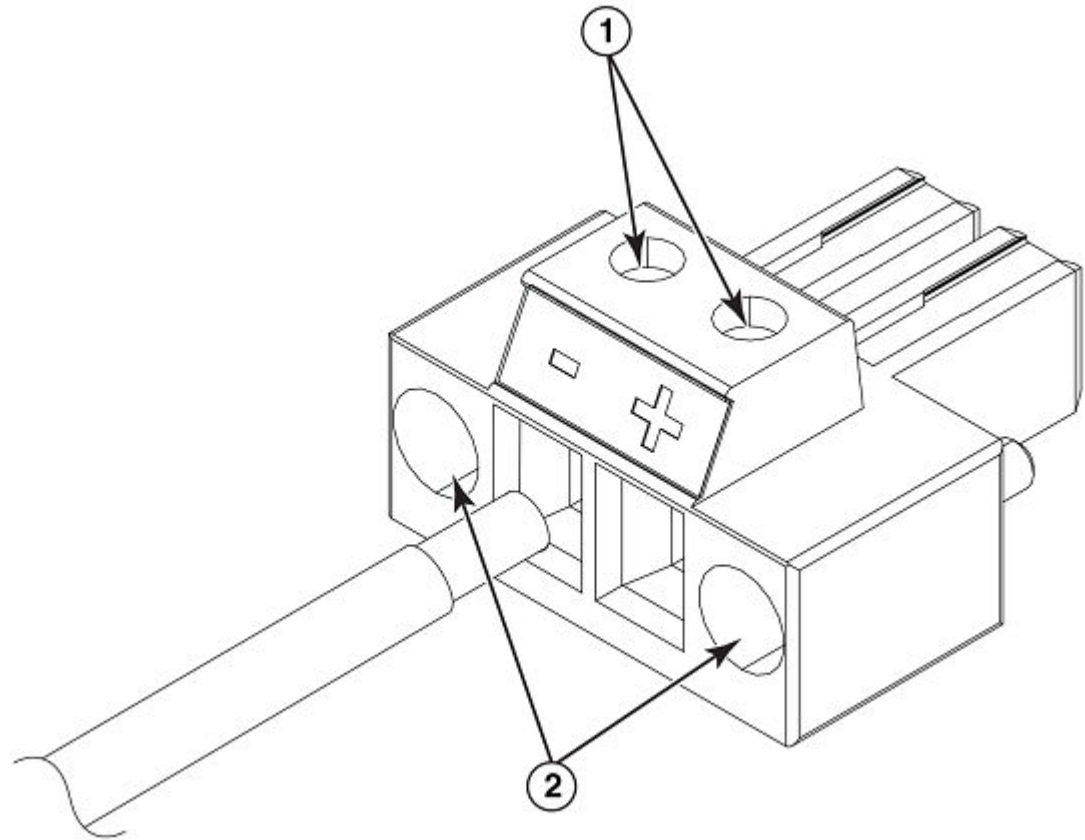

1 Wire tightening screws

2 Assembly screws

7. With one hand, hold the bar on the front panel of the power supply. With the other hand, support the underside of the power supply, and insert the power supply into the empty power supply slot. Press until the supply is completely in the slot, so that the connectors on the back of the supply are fully engaged with the pins on the power backplane ([Installing an AC power supply](#) on page 48).



CAUTION

Carefully follow the mechanical guides on each side of the power supply slot and make sure the power supply is properly inserted in the guides. Never insert the power supply upside down.

NOTE

The power supply is right-side up when the manufacturer label is on the top.

8. Secure the two screws near the edges of the supply to lock the supply in place ([Installing a DC power supply](#)).

FIGURE 40 DC power supply screws

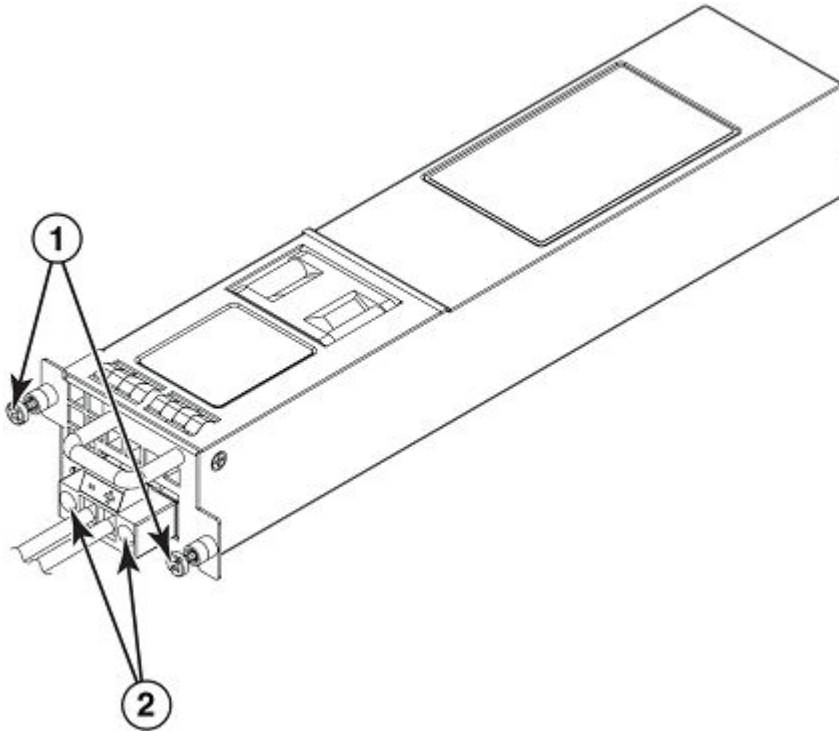

1 Chassis attachment screws

2 Assembly screws

9. Connect the wire to your DC power source, making sure to connect the -48V cable to the negative terminal on the power supply and the 0V cable to the positive terminal as marked on the power supply.

The equipment installation must meet NEC/CEC code requirements. Consult local authorities for regulations.



DANGER

Make sure that the power source circuits are properly grounded, then use the power cord supplied with the device to connect it to the power source.

NOTE

Ensure that the DC return is isolated from the chassis ground (DC-I) when connections to the power supply are made.



CAUTION

For a DC system, use a grounding wire of at least 6 American Wire Gauge (AWG). The 6 AWG wire should be attached to an agency-approved crimp connector crimped with the proper tool. The crimp connector should allow for securement to both ground screws on the enclosure. For the Ground lug, use UL listed Panduit crimp connector, P/N LCD6-10A, and two 10-32, PPH, screws to secure crimp connector to chassis. Grounding position is located on the side of the chassis adjacent ground symbol.

NOTE

To insure adequate bonding when attaching the provided Panduit LCD6-10AF two-hole ground lug, a minimum of 20 inch pounds of torque is required to be applied to the mounting hardware used to attach the ground lug. Use a star washer to ensure an NEBS compliant connection.

Device installation

You can install devices on a desktop, or in an equipment rack.

Installing the device on a desktop

Follow the steps for desktop installation.

1. Set the device on a flat desktop, table, or shelf. Make sure that adequate ventilation is provided for the system - a 3-inch clearance is recommended on each side.
2. Go to [System power](#) on page 57.

Installing the device in a rack

<<This section is also in the FGS HW Install Guide. Any changes here should also be made there.>>

For rack mount installation, Brocade recommends that you use the rack mount ears attached to the unit. Each unit ships with rack ears attached to the front of the unit. You can mount the rack ears in 4 different locations on the device.

NOTE

While attaching the chassis to the rack, star washers shall be used to provide better grounding of the chassis to the rack. Additionally if any single hole grounding lugs are used star washers shall be used as a means to prevent rotation of the lug.

Forward rack mount position

The Brocade devices ship with the rack ears attached to the front of the device as shown below.

FIGURE 41 Front rack mount position

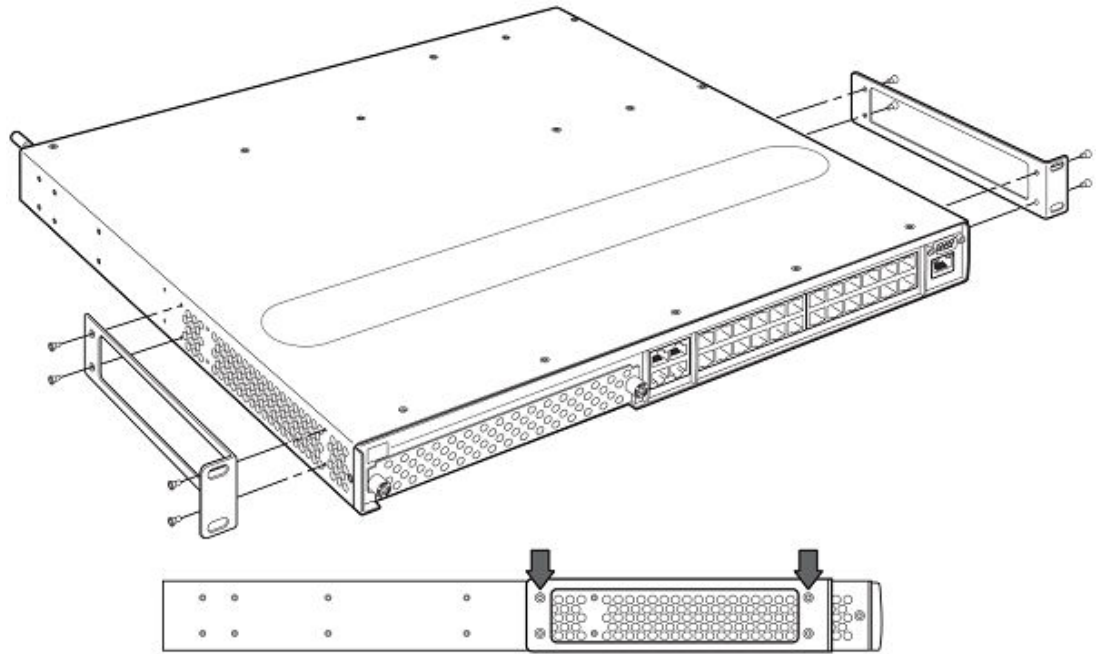

5 Inch offset rack mount position

FIGURE 42 5 Inch offset rack mount position

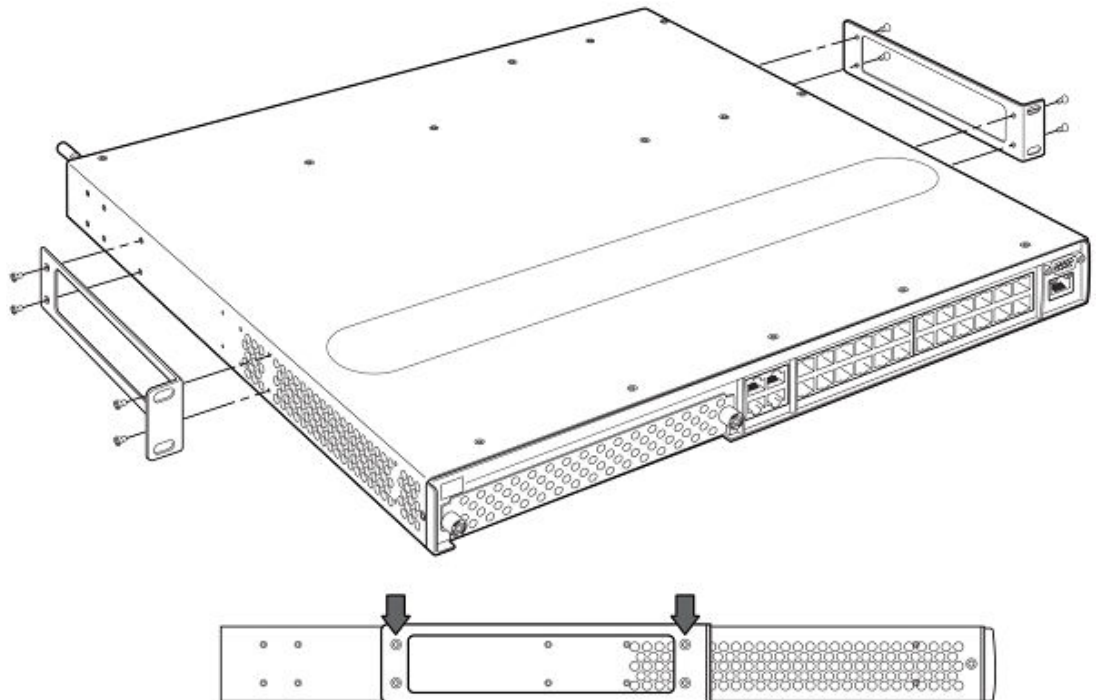

Mid rack mount position

FIGURE 43 Mid rack mount position

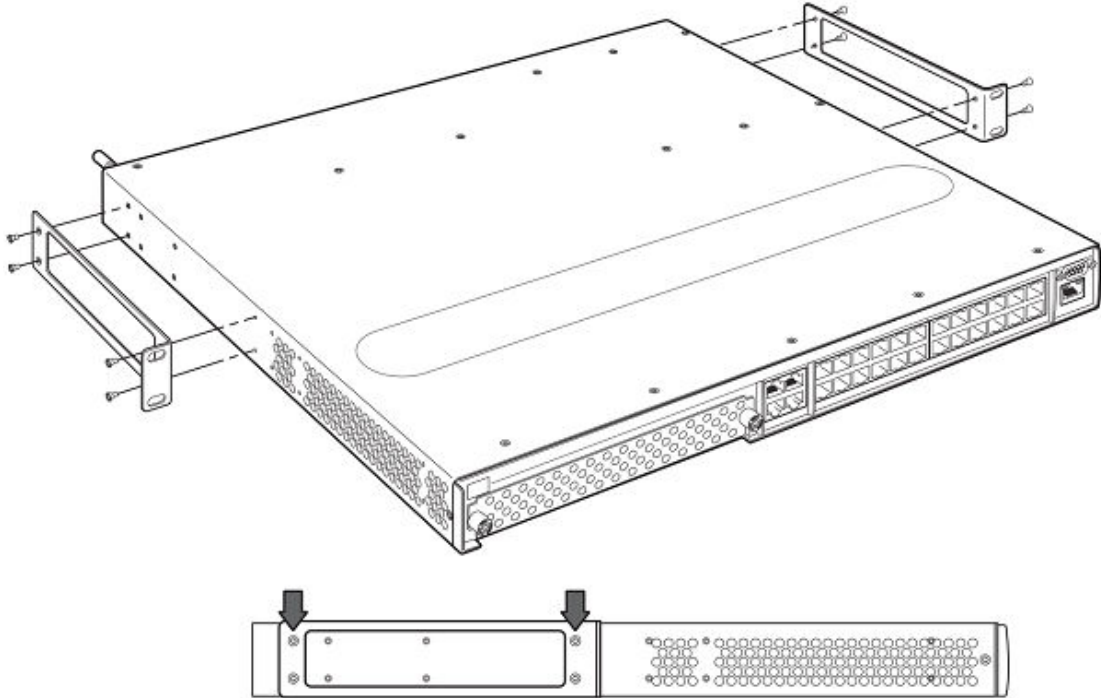

Reverse rack mount position

FIGURE 44 Reverse rack mount position

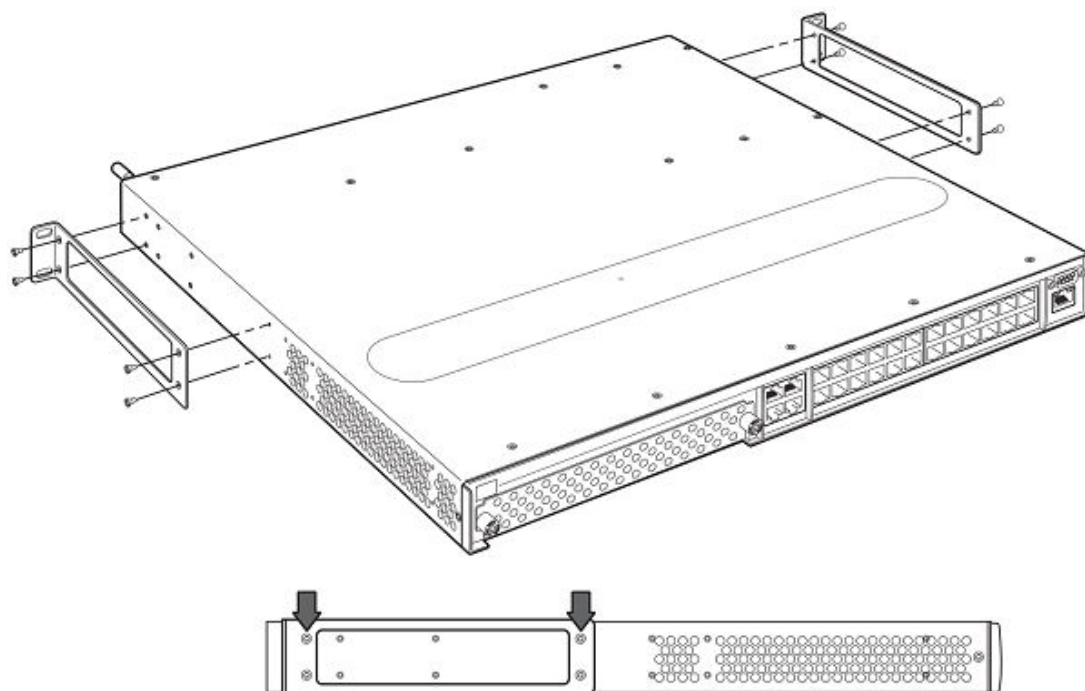
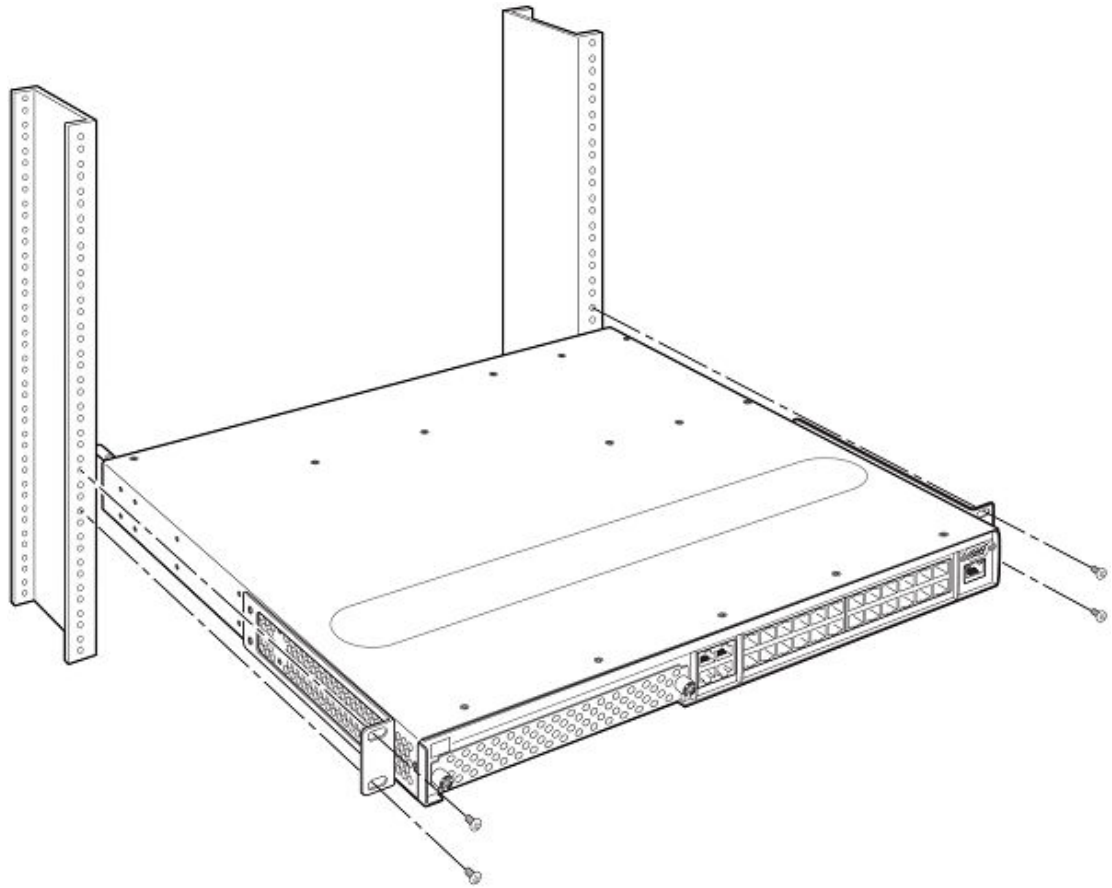

FIGURE 45 Installing the Brocade device in a rack

Installation steps

1. Mount the device in the rack as illustrated in [Reverse rack mount position](#) on page 56.
2. Using a 2-hole grounding lug and a minimum #6 AWG grounding wire, ground the chassis to either a common bonding network or an isolated bonding network.
3. Proceed to [System power](#) on page 57.

You will need the following tools for installation:

- #2 Phillips-head screwdriver
- Four #10-24 screws (or as specified by rack type) to mount the device to the rack

System power

After you complete the physical installation of the system, you can power on the system.

Powering on the system

1. Ensure that all power supplies are fully and properly inserted and no power supply slots are uncovered.



CAUTION

Never leave tools inside the chassis.

2. Remove the power cord from the shipping package.
3. Attach the AC power cable to the AC connector on the rear panel.
4. Insert the power cable plug into a 115V/120V outlet.

NOTE

To turn the system off, simply unplug the power cords.

NOTE

The socket should be installed near the equipment and should be easily accessible.

NOTE

If the outlet is not rated 115/120V, stop and get the appropriate cable for the outlet.



DANGER

The intra-building port or ports of the equipment or subassembly is suitable for connection to intra-building or unexposed wiring or cabling only. The intra-building port or ports of the equipment or subassembly MUST NOT be metallically connected to interfaces that connect to the outside plant (OSP) or its wiring. These interfaces are designed for use as intra-building interfaces only (Type 2 or Type 4 ports as described in GR-1089-CORE, Issue 5) and require isolation from the exposed OSP cabling. The addition of Primary Protectors is not sufficient protection in order to connect these interfaces metallically to OSP wiring.

NOTE

Before crimping the ground wire into the provided ground lug ensure the bare copper wire has been cleaned and antioxidant is applied to the bare wire. To ensure adequate bonding when attaching the ground lug, a minimum of 20 PSI of torque is required to be applied to the mounting hardware used to attach the ground lug.

Operation verification

After you have installed any redundant power supplies, verify that the device is working properly by plugging it into a power source and verifying that it passes its self test.

If your device has more than one power supply installed, repeat this procedure for each power supply.

Verifying proper operation

1. Connect the power cord supplied with the device to the power connector on the power supply on the rear of the device.
2. Insert the other end into a properly grounded electrical outlet.
3. Verify that the LED for each power supply is a solid green.
4. Verify proper operation by observing the LEDs.

All the port LEDs should flash momentarily, usually in sequence, while the device performs diagnostics. After the diagnostics are complete, the LEDs will be dark except for the ones that are attached by cables to other devices. If the links on these cables are good and the connected device is powered on, the link LEDs will light.

Observing the power status LEDs

The LEDs that show power status for the Brocade NetIron CES Series and Brocade NetIron CER Series 2024 models are listed in the table below. The LEDs for the 2024 models are stacked on the right side of the front panel, just below the console port, labeled P1, P2, and Fn, top to bottom to right.

TABLE 9 LEDs for power and fan status for the 2024 models

LED	Position	State	Meaning
Fan (labeled Fn)	Right side of front panel	Green	The fan tray is powered on and is operating normal
		Amber or green blinking	The fan tray is not plugged in.
		Amber	The fan tray is plugged in but one or more fans are faulty.
AC PS1 (labeled P1)	Right side of front panel	Off	Power supply 1 is not installed or is not providing power.
		Amber	Power supply 1 is installed, but not connected or a fault is detected.
		Green	Power supply 1 is installed and is functioning normally.
AC PS2 (labeled P2)	Right side of front panel	Off	Power supply 2 is not installed or is not providing power.
		Amber	Power supply 2 is installed, but not connected or a fault is detected.
		Green	Power supply 2 is installed and is functioning normally.
Power Supplies DC - same indications for both DC power supplies			
DC	Right side of front panel	Off	No DC power.

TABLE 9 LEDs for power and fan status for the 2024 models (Continued)

LED	Position	State	Meaning
		Amber	Supply has DC power, but output is not enabled.
		Green	Supply has DC power, is enabled, and has good output.

The LEDs that show power status for the Brocade NetIron CES Series and Brocade NetIron CER Series 2048 models are listed in the table below. The LEDs for the 2048CX, 2048F, and 2048FX models are just below the management Ethernet port on the left side of the front panel, labeled P1, P2, and Fn, left to right. The LEDs for the 2048C are just below the console connector on the left side of the front panel, labeled P1, P2, and Fn, left to right.

TABLE 10 LEDs for power for the 2048 models

LED	Position	State	Meaning
Fan (labeled Fn)	Left side of front panel	Green	The fan tray is powered on and is operating normal.
		Amber or green blinking	The fan tray is not plugged in.
		Amber	The fan tray is plugged in but one or more fans are faulty.
PS1 (labeled P1)	Left side of front panel	Off	Power supply 1 is not installed or is not providing power.
		Amber	Power supply 1 is installed, but not connected or a fault is detected.
		Green	Power supply 1 is installed and is functioning normally.
PS2 (labeled P2)	Left side of front panel	Off	Power supply 2 is not installed or is not providing power.
		Amber	Power supply 2 is installed, but not connected or a fault is detected.
		Green	Power supply 2 is installed and is functioning normally.
DC	Right side of front panel	Off	No DC power.
		Amber	The following possibilities: <ul style="list-style-type: none"> • The power supply has DC power, but output is not enabled • The power supply is over temperature • The fan failed

TABLE 10 LEDs for power for the 2048 models (Continued)

LED	Position	State	Meaning
		Green	Power supply has DC power, is enabled, and has good output.
		Green blinking	Power supply has input power, but DC output is not enabled.

The software regularly polls the hardware for power status information. You can display the status information from any management session. In addition, the software automatically generates a Syslog message and SNMP trap if a status change occurs.

PC or terminal attachment

To assign an IP address, you must have access to the Command Line Interface (CLI). The CLI is a text-based interface that can be accessed through a direct serial connection to the device and through Telnet connections.

You need to assign an IP address using the CLI. You can access the CLI by attaching a serial cable to the Console port. After you assign an IP address, you can access the system through Telnet or Brocade Network Advisor.

Attaching a PC or terminal

Follow the steps given below to attach a management station using the serial port.

1. Connect a PC or terminal to the serial port of the system using a straight-through cable. The serial port has a male DB-9 connector.

NOTE

You need to run a terminal emulation program on the PC.

2. Open the terminal emulation program and set the session parameters as follows:

- Baud: 9600 bps
- Data bits: 8
- Parity: None
- Stop bits: 1
- Flow control: None

When you establish the serial connection to the system, press Enter to display the CLI prompt in the terminal emulation window. For example:

```
device>
```

If you see this of these prompt, you are now connected to the system and can proceed to [Attaching a PC or terminal](#).

You can customize the prompt by changing the system name. For more information, refer to the *Brocade Multi-Service IronWare Configuration Guide*.

If you do not see one of these prompts, follow the instructions given below.

3. Make sure the cable is securely connected to your PC and to the system.
4. Check the settings in your terminal emulation program. In addition to the session settings listed above, make sure the terminal emulation session is running on the same serial port you attached to the system.

The EIA/TIA 232 serial communication port serves as a connection point for management by a PC or SNMP workstation.

Device Management Applications Familiarization

- [Management application overview](#).....63
- [CLI Functionality](#)..... 63

Management application overview

This chapter describes the different applications you can use to manage the devices. The Brocade devices support the same management applications as other devices.

As with other devices, you can manage a device using any of the following applications:

- Command Line Interface (CLI) - a text-based interface accessible directly from a PC or terminal attached to the device's serial (Console) port or 10BaseT/100BaseTX Ethernet (management) port, or from a Telnet connection to the PC or terminal.
- Brocade Network Advisor - An optional SNMP-based standalone GUI application. For more information see the *Unified IP MIB reference manual* .

The following section describes how to log on to these applications.

CLI Functionality

Once an IP address is assigned to the Brocade device's management port, you can access the CLI through a PC or terminal attached to the device's serial (Console) port or 10BaseT/100BaseTX Ethernet (management) port, or from a Telnet or SSH connection to the PC or terminal.

You can initiate a local Telnet, SSH or SNMP connection by specifying the management port's IP address.

The commands in the CLI are organized into the following levels:

- User EXEC - Lets you display information and perform basic tasks such as pings and traceroutes.
- Privileged EXEC - Lets you use the same commands as those at the User EXEC level plus configuration commands that do not require saving the changes to the system-config file.
- CONFIG - Lets you make configuration changes to the device. To save the changes across software reloads and system resets, you need to save them to the system-config file. The CONFIG level contains sub-levels for individual ports, for VLANs, for routing protocols, and other configuration areas.

NOTE

By default, any user who can open a direct or Telnet connection to a Brocade device can access all these CLI levels. To secure access, you can configure Enable passwords or local user accounts, or you can configure the device to use a RADIUS or TACACS/TACACS+ server for authentication.

Online help

To display a list of available commands or command options, enter "?" or press Tab. If you have not entered part of a command at the command prompt, all the commands supported at the current CLI level are listed. If you enter part of a command, then enter "?" or press Tab, the CLI lists the options you can enter at this point in the command string.

If you enter an invalid command followed by ?, a message appears indicating the command was unrecognized. For example.

```
device(config)# router ip?
Unrecognized command
```

Command completion

The CLI supports command completion, so you do not need to enter the entire name of a command or option. As long as you enter enough characters of the command or option name to avoid ambiguity with other commands or options, the CLI understands what you are typing.

Scroll control

By default, the CLI uses a page mode to paginate displays that are longer than the number of rows in your terminal emulation window. For example, if you display a list of all the commands at the global CONFIG level but your terminal emulation window does not have enough rows to display them all at once, the page mode stops the display and lists your choices for continuing the display.

Here is an example.

```
aaa
access-list
all-client
arp
banner
base-mac-addr
boot
some lines omitted for brevity...
  default-vlan-id
  enable
  enable-acl-counter
  end
  exit
--More--, next page: Space, next line: Return key, quit: Control-c
```

The software provides the following scrolling options:

- Press the **Space bar** to display the next page (one screen at time).
- Press the **Return** or **Enter** key to display the next line (one line at a time).
- Press **Ctrl-C** cancel the display.

Line editing commands

The CLI supports the following line editing commands. To enter a line-editing command, use the CTRL-key combination for the command by pressing and holding the CTRL key, then pressing the letter associated with the command.

TABLE 11 CLI line editing commands

Ctrl-key combination	Description
Ctrl-A	Moves to the first character on the command line.
Ctrl-B	Moves the cursor back one character.
Ctrl-C	Escapes and terminates command prompts and ongoing tasks (such as lengthy displays), and displays a fresh command prompt.
Ctrl-D	Deletes the character at the cursor.
Ctrl-E	Moves to the end of the current command line.
Ctrl-F	Moves the cursor forward one character.
Ctrl-K	Deletes all characters from the cursor to the end of the command line.
Ctrl-L; Ctrl-R	Repeats the current command line on a new line.
Ctrl-N	Enters the next command line in the history buffer.
Ctrl-P	Enters the previous command line in the history buffer.
Ctrl-U; Ctrl-X	Deletes all characters from the cursor to the beginning of the command line.
Ctrl-W	Deletes the last word you typed.
Ctrl-Z	Moves from any CONFIG level of the CLI to the Privileged EXEC level; at the Privileged EXEC level, moves to the User EXEC level.

For a complete list of CLI commands and syntax information for each command, refer to *Brocade Multi-Service IronWare Configuration Guide*.

Searching and filtering output from CLI commands

You can filter CLI output from **show** commands and at the `--More--` prompt. You can search for individual characters, strings, or construct complex regular expressions to filter the output.

Searching and filtering output from show commands

You can filter output from **show** commands to display lines containing a specified string, lines that do not contain a specified string, or output starting with a line containing a specified string. The search string is a regular expression consisting of a single character or string of characters. You can use special characters to construct complex regular expressions. Refer to [Using special characters in regular expressions](#) on page 68 for information on special characters used with regular expressions.

Displaying lines containing a specified string

The following command filters the output of the **show interface** command for port 3/1 so it displays only lines containing the word "Internet". This command can be used to display the IP address of the interface.

```
device# show interface e 3/1 | include Internet
Internet address is 192.168.1.11/24, MTU 1518 bytes, encapsulation ethernet
```

Syntax: `include show-command | regular-expression`

NOTE

The vertical bar (|) is part of the command.

Note that the regular expression specified as the search string is case sensitive. In the example above, a search string of "Internet" would match the line containing the IP address, but a search string of "internet" would not.

Displaying lines that do not contain a specified string

The following command filters the output of the **show who** command so it displays only lines that do not contain the word "closed". This command can be used to display open connections to a Brocade device.

```
device# show who | exclude closed
Console connections:
    established
    you are connecting to this session
    2 seconds in idle
Telnet connections (inbound):
    1    established, client ip address 192.168.9.37
        27 seconds in idle
Telnet connection (outbound):
SSH connections:
```

Syntax: `exclude show-command | regular-expression`

Displaying lines starting with a specified string

The following command filters the output of the **show who** command so it displays output starting with the first line that contains the word "SSH". This command can be used to display information about SSH connections to the Brocade device.

```
device# show who | begin SSH
SSH connections:
    1    established, client ip address 192.168.9.210
        7 seconds in idle
    2    closed
    3    closed
    4    closed
    5    closed
```

Syntax: `begin show-command | regular-expression`

Searching and filtering output at the --More-- prompt

The --More-- prompt displays when output extends beyond a single page. From this prompt, you can press the **Space bar** to display the next page, the **Return** or **Enter** key to display the next line, or

Ctrl-C to cancel the display. In addition, you can search and filter output from this prompt. For example.

```
device# ?
  append          Append one file to another
  attrib          Change file attribute
  boot            Boot system from bootp/tftp server/flash image
  cd              Change current working directory
  chdir           Change current working directory
  clear           Clear table/statistics/keys
  clock           Set clock
  configure       Enter configuration mode
  copy            Copy between flash, tftp, config/code
  cp              Copy file commands
  debug           Enable debugging functions (see also 'undebug')
  delete          Delete file on flash
  dir             List files
  dm              test commands
  dot1x           802.1X
  erase           Erase image/configuration files from flash
  exit            Exit Privileged mode
  fastboot        Select fast-reload option
  force-sync-standby Sync active flash (pri/sec/mon/startup config/lp images)
                  to standby
  format          Format PCMCIA card
  hd              Hex dump
  ipc             IPC commands
--More--, next page: Space, next line: Return key, quit: Control-c
```

At the `--More--` prompt, you can press the forward **slash** key (`/`) and then enter a search string. The device displays output starting from the first line that contains the search string, similar to the *begin* option for **show** commands. For example.

```
--More--, next page: Space, next line: Return key, quit: Control-c
/telnet
```

The results of the search are displayed.

```
searching...
telnet          Telnet by name or IP address
terminal        Change terminal settings
traceroute      TraceRoute to IP node
undelete        Recover deleted file
whois           WHOIS lookup
write           Write running configuration to flash or terminal
```

To display lines containing only a specified search string (similar to the *include* option for **show** commands) press the **plus** sign key (`+`) at the `--More--` prompt and then enter the search string.

```
--More--, next page: Space, next line: Return key, quit: Control-c
+telnet
```

The filtered results are displayed.

```
filtering...
telnet          Telnet by name or IP address
```

To display lines that do not contain a specified search string (similar to the *exclude* option for **show** commands) press the **minus** sign key (`-`) at the `--More--` prompt and then enter the search string.

```
--More--, next page: Space, next line: Return key, quit: Control-c
-telnet
```

The filtered results are displayed.

```
filtering...
sync-standby    Sync active flash (pri/sec/mon/startup config/lp images)
                  to standby if different
terminal        Change terminal settings
traceroute      TraceRoute to IP node
undelete        Recover deleted file
```

```
whois          WHOIS lookup
write         Write running configuration to flash or terminal
```

As with the commands for filtering output from **show** commands, the search string is a regular expression consisting of a single character or string of characters. You can use special characters to construct complex regular expressions. See the next section for information on special characters used with regular expressions.

Using special characters in regular expressions

You use a regular expression to specify a single character or multiple characters as a search string. In addition, you can include special characters that influence the way the software matches the output against the search string. These special characters are listed in the following table.

TABLE 12 Special characters for regular expressions

Character	Operation
.	<p>The period matches on any single character, including a blank space.</p> <p>For example, the following regular expression matches "aaz", "abz", "acz", and so on, but not just "az":</p> <p>a.z</p>
*	<p>The asterisk matches on zero or more sequential instances of a pattern.</p> <p>For example, the following regular expression matches output that contains the string "abc", followed by zero or more Xs:</p> <p>abcX*</p>
+	<p>The plus sign matches on one or more sequential instances of a pattern.</p> <p>For example, the following regular expression matches output that contains "de", followed by a sequence of "g"s, such as "deg", "degg", "deggg", and so on:</p> <p>deg+</p>
?	<p>The question mark matches on zero occurrences or one occurrence of a pattern.</p> <p>For example, the following regular expression matches output that contains "dg" or "deg":</p> <p>de?g</p>
<p>NOTE</p> <p>Normally when you type a question mark, the CLI lists the commands or options at that CLI level that begin with the character or string you entered. However, if you enter Ctrl-V and then type a question mark, the question mark is inserted into the command line, allowing you to use it as part of a regular expression.</p>	
^	<p>A caret (when not used within brackets) matches on the beginning of an input string.</p> <p>For example, the following regular expression matches output that begins with "deg":</p> <p>^deg</p>
\$	<p>A dollar sign matches on the end of an input string.</p> <p>For example, the following regular expression matches output that ends with "deg":</p> <p>deg\$</p>

TABLE 12 Special characters for regular expressions (Continued)

Character	Operation
<code>_</code>	<p>An underscore matches on one or more of the following:</p> <ul style="list-style-type: none"> • <code>,</code> (comma) • <code>{</code> (left curly brace) • <code>}</code> (right curly brace) • <code>(</code> (left parenthesis) • <code>)</code> (right parenthesis) • The beginning of the input string • The end of the input string • A blank space <p>For example, the following regular expression matches on "100" but not on "1002", "2100", and so on:</p> <pre>_100_</pre>
<code>[]</code>	<p>Square brackets enclose a range of single-character patterns.</p> <p>For example, the following regular expression matches output that contains "1", "2", "3", "4", or "5":</p> <pre>[1-5]</pre> <p>You can use the following expression symbols within the brackets. These symbols are allowed only inside the brackets.</p> <ul style="list-style-type: none"> • <code>^</code> - The caret matches on any characters except the ones in the brackets. For example, the following regular expression matches output that does not contain "1", "2", "3", "4", or "5": <code>[^1-5]</code> • <code>-</code> - The hyphen separates the beginning and ending of a range of characters. A match occurs if any of the characters within the range is present. See the example above.
<code> </code>	<p>A vertical bar separates two alternative values or sets of values. The output can match one or the other value.</p> <p>For example, the following regular expression matches output that contains either "abc" or "defg":</p> <pre>abc defg</pre>
<code>()</code>	<p>Parentheses allow you to create complex expressions.</p> <p>For example, the following complex expression matches on "abc", "abcabc", or "defg", but not on "abcdefgdefg":</p> <pre>((abc)+)((defg)?)</pre>

If you want to filter for a special character instead of using the special character as described in the table above, enter `"\"` (**backslash**) in front of the character.

Hardware Specifications

- [Power specifications](#)..... 71
- [Physical dimensions](#).....72
- [Operating environment](#)74
- [Storage environment](#)74
- [Cooling](#)..... 75
- [Safety agency approvals](#).....75
- [Electromagnetic approvals](#).....75
- [Port specifications](#).....75

Power specifications

This section contains the power specifications for the Brocade devices.

[Table 13](#) provides the minimum and maximum voltage and current ratings.

TABLE 13 Brocade operating voltage and current

Power supply	Voltage	Current	Inrush current
AC	100-240 VAC	6 A	30A Peak @ 25C
DC	48 VDC	15 A	25A Peak @ 25C

[Table 14](#) provides the maximum power calculations.

TABLE 14 Maximum power calculations at 100-240 VAC with two PSUs

Devices	Watts	BTUs per hour
Brocade NetIron CES Series 2024C-4X	200	682
Brocade NetIron CES Series 2024C-4X with 4x10G uplink installed	256	875
Brocade NetIron CES Series 2024C	120	410
Brocade NetIron CES Series 2024C with 2x10G uplink installed	170	580
Brocade NetIron CES Series 2024F-4X	203	692
Brocade NetIron CES Series 2024F-4X with 4x10G uplink installed	268	915
Brocade NetIron CES Series 2024F	145	495

TABLE 14 Maximum power calculations at 100-240 VAC with two PSUs (Continued)

Devices	Watts	BTUs per hour
Brocade NetIron CES Series 2024F with 2x10G uplink installed	195	666
Brocade NetIron CES Series 2048C	205	700
Brocade NetIron CES Series 2048CX	255	870
Brocade NetIron CES Series 2048F	245	836
Brocade NetIron CES Series 2048FX	295	1007
Brocade NetIron CER Series 2024C-4X-RT	217	741
Brocade NetIron CER Series 2024C-4X-RT with 4x10G uplink installed	266	907
Brocade NetIron CER Series 2024C	135	461
Brocade NetIron CER Series 2024C with 2x10G uplink installed	205	700
Brocade NetIron CER Series 2024F-4X-RT	219	747
Brocade NetIron CER Series 2024F-4X with 4x10G uplink installed	315	1076
Brocade NetIron CER Series 2024F	165	546
Brocade NetIron CER Series 2024F with 2x10G uplink installed	230	785
Brocade NetIron CER Series 2048C	240	819
Brocade NetIron CER Series 2048CX	310	1041
Brocade NetIron CER Series 2048F	295	956
Brocade NetIron CER Series 2048FX	365	1195

Physical dimensions

[Table 15](#) provides the physical dimensions for the Brocade devices.

TABLE 15 Physical dimensions of the Brocade devices

Devices	Height	Width	Depth	Weight (fully-loaded) (LB)
Brocade NetIron CES Series 2024C-4X	1 RU1.7 inches4.4 cm	17.44 in44.3 cm	17.30 in43.9 cm	20.65

TABLE 15 Physical dimensions of the Brocade devices (Continued)

Devices	Height	Width	Depth	Weight (fully-loaded) (LB)
Brocade NetIron CES Series 2024C-4X with 4x10G uplink installed	1 RU1.7 inches4.4 cm	17.44 in44.3 cm	17.30 in43.9 cm	20.95
Brocade NetIron CES Series 2024C	1 RU1.7 inches4.4 cm	17.44 in44.3 cm	17.64 in44.8 cm	15.5
Brocade NetIron CES Series 2024C with 2x10G uplink installed	1 RU1.7 inches4.4 cm	17.44 in44.3 cm	17.64 in44.8 cm	17.5
Brocade NetIron CES Series 2024F-4X	1 RU1.7 inches4.4 cm	17.44 in44.3 cm	17.30 in43.9 cm	21.05
Brocade NetIron CES Series 2024F-4X with 4x10G uplink installed	1 RU1.7 inches4.4 cm	17.44 in44.3 cm	17.30 in43.9 cm	21.35
Brocade NetIron CES Series 2024F	1 RU1.7 inches4.4 cm	17.44 in44.3 cm	17.64 in44.8 cm	15.5
Brocade NetIron CES Series 2024F with 2x10G uplink installed	1 RU1.7 inches4.4 cm	17.44 in44.3 cm	17.64 in44.8 cm	17.5
Brocade NetIron CES Series 2048C	1 RU1.7 inches4.4 cm	17.44 in44.3 cm	17.25 in43.9 cm	16.5
Brocade NetIron CES Series 2048CX	1 RU1.7 inches4.4 cm	17.44 in44.3 cm	17.25 in43.9 cm	17.5
Brocade NetIron CES Series 2048F	1 RU1.7 inches4.4 cm	17.44 in44.3 cm	17.25 in43.9 cm	16.5
Brocade NetIron CES Series 2048FX	1 RU1.7 inches4.4 cm	17.44 in44.3 cm	17.25 in43.9 cm	17.5
Brocade NetIron CER Series 2024C-4X-RT	1 RU1.7 inches4.4 cm	17.44 in44.3 cm	17.64 in44.8 cm	20.9
Brocade NetIron CER Series 2024C-4X-RT with 4x10G uplink installed	1 RU1.7 inches4.4 cm	17.44 in44.3 cm	17.30 in43.9 cm	21.2
Brocade NetIron CER Series 2024C	1 RU1.7 inches4.4 cm	17.44 in44.3 cm	17.30 in43.9 cm	15.5
Brocade NetIron CER Series 2024C with 2x10G uplink installed	1 RU1.7 inches4.4 cm	17.44 in44.3 cm	17.64 in44.8 cm	17.5
Brocade NetIron CER Series 2024F-4X-RT	1 RU1.7 inches4.4 cm	17.44 in44.3 cm	17.30 in43.9 cm	20.8

TABLE 15 Physical dimensions of the Brocade devices (Continued)

Devices	Height	Width	Depth	Weight (fully-loaded) (LB)
Brocade NetIron CER Series 2024F-4X-RT with 4x10G uplink installed	1 RU1.7 inches4.4 cm	17.44 in44.3 cm	17.30 in43.9 cm	21.8
Brocade NetIron CER Series 2024F	1 RU1.7 inches4.4 cm	17.44 in44.3 cm	17.64 in44.8 cm	15.5
Brocade NetIron CER Series 2024F with 2x10G uplink installed	1 RU1.7 inches4.4 cm	17.44 in44.3 cm	17.64 in44.8 cm	17.5
Brocade NetIron CER Series 2048C	1 RU1.7 inches4.4 cm	17.44 in44.3 cm	17.3 in43.9 cm	16.5
Brocade NetIron CER Series 2048CX	1 RU1.7 inches4.4 cm	17.44 in44.3 cm	17.3 in43.9 cm	17.5
Brocade NetIron CER Series 2048F	1 RU1.7 inches4.4 cm	17.44 in44.3 cm	17.3 in43.9 cm	16.5
Brocade NetIron CER Series 2048FX	1 RU1.7 inches4.4 cm	17.44 in44.3 cm	17.3 in43.9 cm	17.5

Operating environment

The following table [Table 16](#) provides the operating environment specifications for the Brocade devices.

TABLE 16 Brocade operating environment

Operating temperature	Relative humidity	Operating altitude
0 o C to 40 o C (32 o F to 104 o F)	5% to 90%, at 40 o C (104 o F), non-condensing	10,000 ft (3,048 m)

Storage environment

The following table [Table 17](#) provides the storage environment specifications for the devices.

TABLE 17 Brocade storage environment

Storage temperature	Storage humidity	Storage altitude
-25 o C to 70 o C (-13 o F to 158 o F)	95% maximum relative humidity, non-condensing	15,000 ft (4,500 m) maximum

Cooling

The cooling fans cool the CPU, main memory, and voltage regulators. The fans use a pull configuration to move the air from the front of the device to the back of the device.

- Total cooling capacity: 350 watts
- Total air flow: 267 LFM
- Fan operating noise:
 - Based on ISO 7779
 - < 60 dB-A

Safety agency approvals

- CAN/CSA-22.2 No.60950-1-07/UL 60950-1-Second Edition
- EN 60825-1 Safety of Laser Products - Part 1: Equipment Classification, Requirements and User's Guide
- EN 60825-2 Safety of Laser Products - Part 2: Safety of Optical Fibre Communications Systems
- CE EN60950-1: 2006
- TUV EN60950-1: 2006
- IEC EN60950-1:2005

Electromagnetic approvals

- FCC Part 15, Subpart B (Class A)
- EN 55022 (CE mark) (Class A)
- CISPR-22 (class A)
- ICES-003 (Canada) (Class A)
- AS/NZ 55022 (Australia) (Class A)
- VCCI (Japan) (Class A)
- EN 61000-3-2
- EN 61000-3-3
- EN 61000-6-3

Port specifications

This section provides pin assignments for the following ports:

- Device's console port (serial connector)
- Device's management port (RJ-45 unshielded twisted pair (UTP) connector)



DANGER

*The intra-building port or ports of the equipment or subassembly is suitable for connection to intra-building or unexposed wiring or cabling only. The intra-building port or ports of the equipment or subassembly **MUST NOT** be metalically connected to interfaces that connect to the outside plant (OSP) or its wiring. These interfaces are designed for use as intra-building interfaces only (Type 2 or Type 4 ports as described in GR-1089-CORE, Issue 5) and require isolation from the exposed OSP cabling. The addition of Primary Protectors is not sufficient protection in order to connect these interfaces metalically to OSP wiring.*

Console port pin assignments

The console port is a standard male DB-9 connector, as shown in [Console port pin assignments](#).

FIGURE 46 Console port pin and signalling details

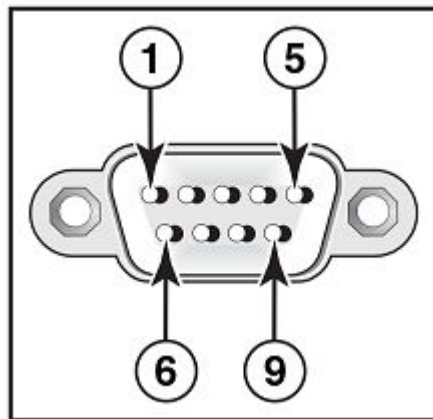

1	Reserved	2	TXD (output)
3	RXD (input)	4	Reserved
5	GND	6	Reserved
7	Reserved	8	Reserved
9	Reserved		

Most PC serial ports require a cable with a female DB-9 connector. However, terminal connections will vary, requiring a cable with either a DB-9 or DB-25 connector, male or female.

Serial cable options between the Brocade device and a PC or terminal are shown in [Figure 47](#).

NOTE

As indicated in [Console port pin assignments](#) and [Figure 47](#), some of the wires should not be connected. If you do connect the wires that are labeled "Reserved", you might get unexpected results with some terminals.

FIGURE 47 Console port pin assignments showing cable connection options to a terminal or PC

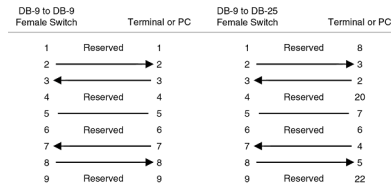

Management port pin assignments

The management port is an RJ-45 UTP connector. [Table 18](#) describes the connector's pin assignments.

TABLE 18 Management port pin assignments

Pin number	MDI-X ports
1	TD+
2	TD-
3	RD+
4	Not used (10BaseT)CMT (100BaseTX)
5	Not used (10BaseT)CMT (100BaseTX)
6	RD-
7	Not used (10BaseT)CMT (100BaseTX)
8	Not used (10BaseT)CMT (100BaseTX)

Hardware Maintenance

- Hardware maintenance schedule.....79
- Power supply replacement.....79
- 10-Gigabit Ethernet module installation or replacement.....91
- Replacing the fan tray.....92
- Copper or Fiber optic module replacement.....93
- Fiber optic connector cleaning.....95

Hardware maintenance schedule



DANGER

The procedures in this manual are for qualified service personnel.

The Brocade device requires minimal maintenance for its hardware components. Brocade recommends cleaning the fiber-optic connectors on a fiber-optic port and the connected fiber cable each time you disconnect the cable.

Otherwise, you can install or replace the following hardware components as needed:

- Copper and fiber optic modules
- Power supplies
- Fan tray
- 2 x10-Gigabit Ethernet module (only on the Brocade NetIron CES Series 2024C, Brocade NetIron CES Series 2024F, Brocade NetIron CER Series 2024C, Brocade NetIron CER Series 2024F models).

Power supply replacement

You can replace a power supply while the Brocade device is powered on and running. The power supplies are located in slots at the rear of the device.

This section provides information about the following topics:

- Installation precautions and warnings
- Determining which power supply has failed, if necessary.
- Replacing a power supply.

NOTE

Power supplies are hot swappable.



CAUTION

Remove the power cord from a power supply before you install it in or remove it from the device. Otherwise, the power supply or the device could be damaged as a result. (The device can be running while a power supply is being installed or removed, but the power supply itself should not be connected to a power source.)

Installation precautions and warnings

Follow these precautions when installing a power supply in the Brocade device.



DANGER

Before beginning the installation, see the precautions in "Power precautions."



CAUTION

Do not install the device in an environment where the operating ambient temperature might exceed 40°C (104°F).



CAUTION

Never leave tools inside the chassis.

Determining which power supply failed

If you are replacing a power supply that has failed and you are not sure which supply has failed, enter the following command at any CLI command prompt.

```
device>show chassis
*** Brocade NetIron CES Series 2024C ***
---POWERS ---
---POWERS ---
Power 1 ( 3I50 - AC 504W): Installed (OK)
Power 2: not present
Total power budget for system = 504 W
--- FANS ---
Metro fan tray (fan 1): Status = OK, Speed = MED (75%)
Metro fan tray (fan 2): Status = OK, Speed = MED (75%)
Metro fan tray (fan 3): Status = OK, Speed = MED (75%)
Metro fan tray (fan 4): Status = OK, Speed = MED (75%)
Metro fan tray (fan 5): Status = OK, Speed = MED (75%)
Metro fan tray (fan 6): Status = OK, Speed = MED (75%)
--- TEMPERATURE READINGS ---
CPU: Ambience 35.50C Chip 39.68C
24X1G PPCR: Ambience 36.0C Chip 47.56C
2X10G PPCR: Ambience 37.50C Chip 43.31C
Fans are in auto mode. Temperature Monitoring Poll Period is 60 seconds
--- MISC INFO ---
Backplane EEPROM MAC Address: 0001.0040.7800
device>
```

This command displays status information for the power supplies and the fans. The power supplies are numbered from left to right. These numbers assume you are facing the front of the device, not the rear.

If the display indicates "Installed (Failed)" for any of the slots, the power supply installed in that particular slot has failed.

AC power supply

The AC power supply is shown in the following diagram.

FIGURE 48 AC power supply

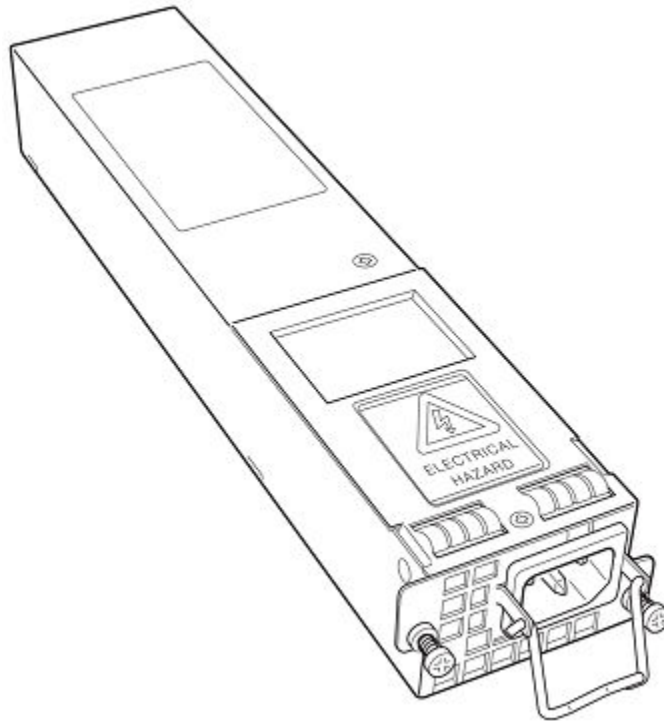

Power supplies for the devices

The device ships with one alternating-current (AC) power supply or direct-current (DC) power supply. All models have two power supply slots, enabling you to install a second power supply for redundancy. If desired, you can install a second supply for redundancy.

If you need to install a redundant power supply, it may be easier to install it before mounting the device, although the power supplies are "hot swappable" and can be installed or removed after the device is mounted and powered on. Brocade recommends that you disconnect the power supply from AC power before installing or removing the supply.



CAUTION

Changes or modifications made to this device that are not expressly approved by the party responsible for compliance could void the user's authority to operate the equipment.

Removing the AC power supply

Required tools

You will need the following tool to perform this procedure:

- #2 Phillips-head screwdriver

The following procedures are required when removing an AC power supplies from a device.

1. Unplug the power supply from the power source.
2. Disconnect the power cord from the power supply.
3. Unscrew the two power supply locking screws located at the top left and bottom right hand corner of the power supply.

FIGURE 49 Power supply screw location

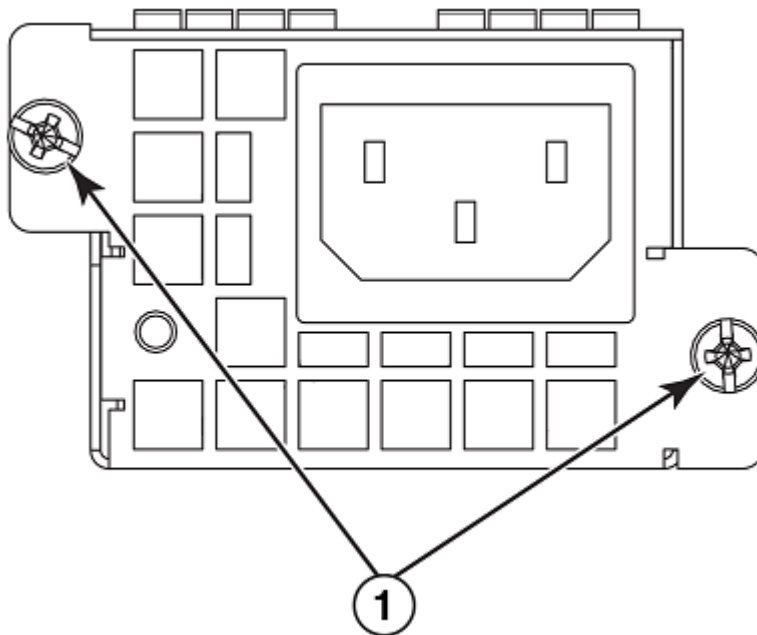

1 Power supply locking screws

4. Pull the power supply outward once the screws have been unscrewed. This will disconnect the power supply from the backplane.

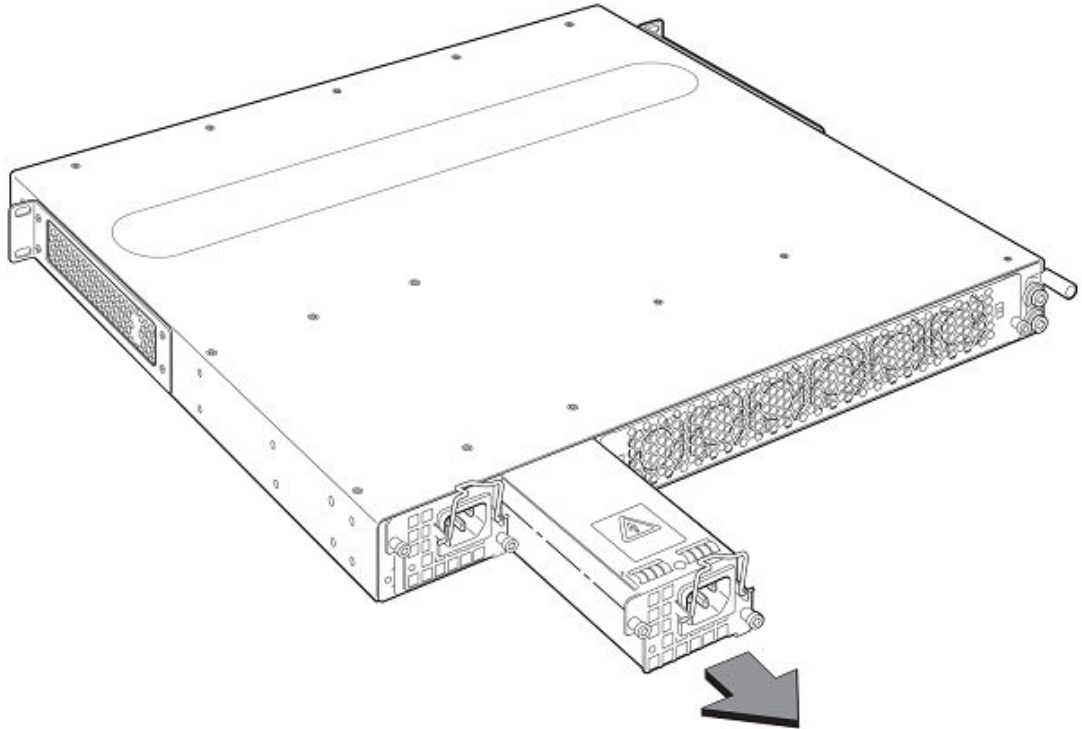
FIGURE 50 Removing the power supply from the device

5. Continue to pull the power supply until it is removed from the device.
6. Place the power supply in an anti-static bag for storage.
7. Insert a new supply, or place and screw in a cover plate over the empty power supply. Refer to [Installing the AC power supply](#) on page 83 for details.

Installing the AC power supply

Perform the following steps to install an AC power supply.

1. Remove the power supply or cover plate currently in the power supply bay you wish to install the power supply in. Refer to [Removing the AC power supply](#) on page 81 for details.
2. Remove the new power supply from its packaging.
3. With one hand, support the underside of the power supply and insert the power supply into the empty power supply slot. Press until the supply is completely in the slot, so that the connectors on the back of the supply are fully engaged with the pins on the power backplane.

FIGURE 51 Power supply installation

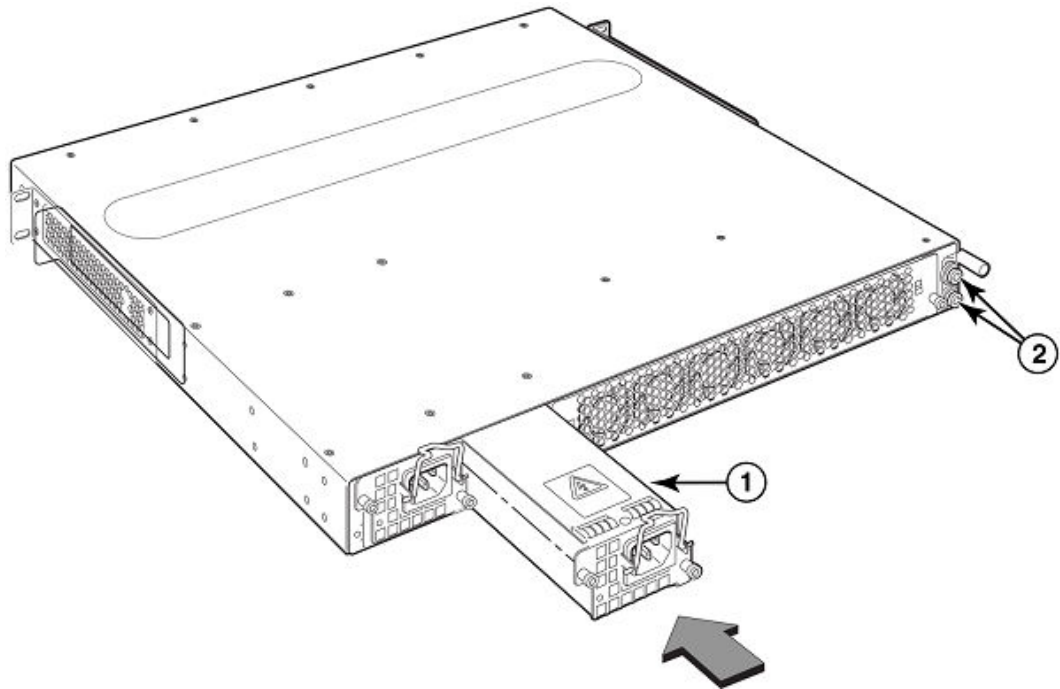

CAUTION

Carefully follow the mechanical guides on each side of the power supply slot and make sure the power supply is properly inserted in the guides. Never insert the power supply upside down.

4. Tighten the two power supply locking screws located at the top left and bottom right hand corner of the power supply.
5. Connect the power cord to the power supply.

Removing the DC power supply

Required tools

You will need the following tool to perform this procedure:

- #2 Phillips-head screwdriver

The following procedures are required when removing an DC power supplies from devices.

1. Remove the wires from your DC power source.
2. Unscrew the two assembly screws to unlock the DC wiring assembly ([Required tools](#)) and remove the adapter.
3. Loosen the wire tightening screws to remove the wires ([Required tools](#)) from the DC wiring assembly.

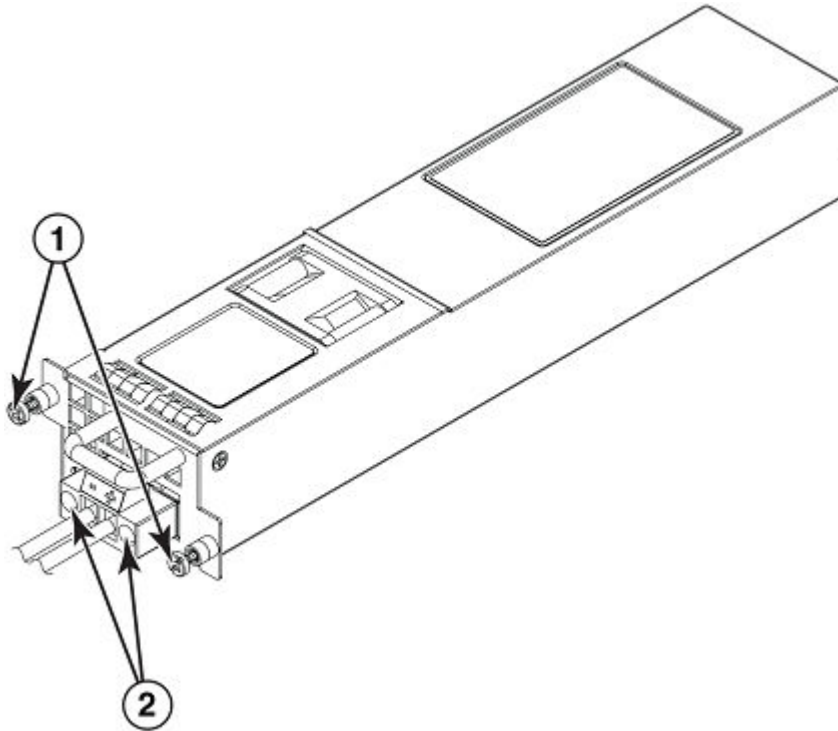
FIGURE 52 DC power supply screws

1 Chassis attachment screws

2 Assembly screws

4. Unscrew the chassis attachment screws to unlock the power supply itself ([Required tools](#)).

FIGURE 53 The DC wiring assembly

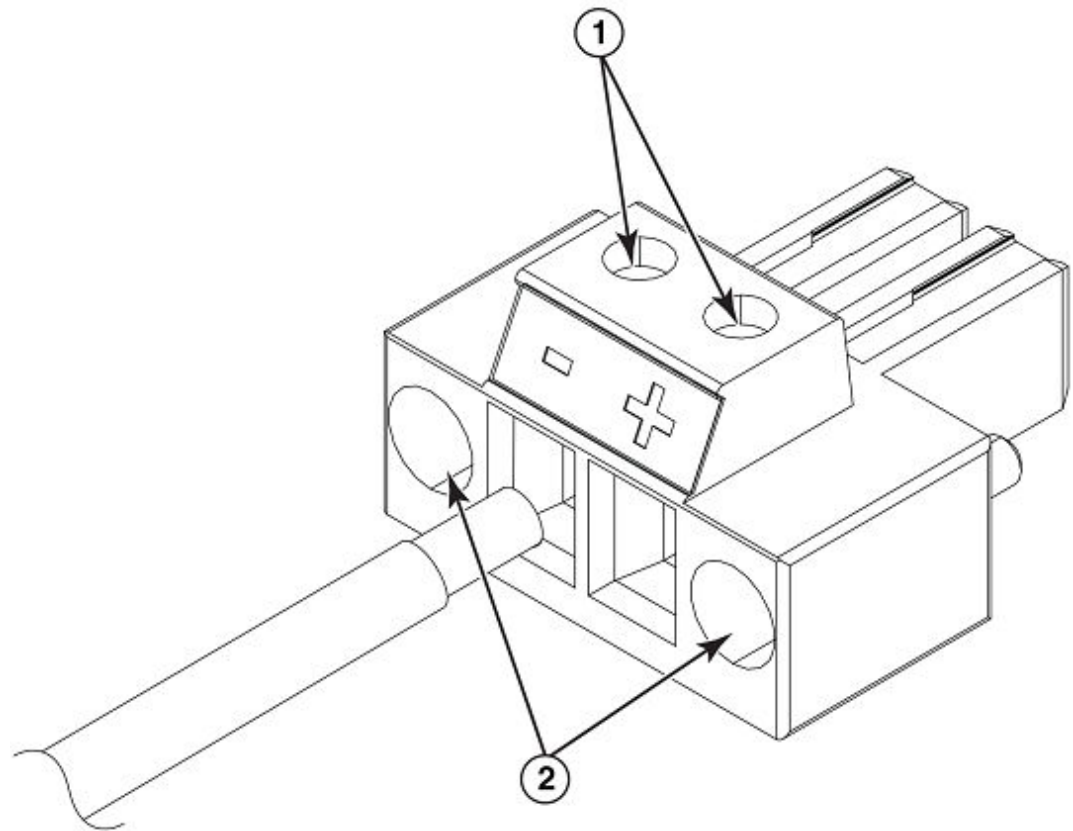

1 Wire tightening screws

2 Assembly screws

5. Pull the power supply outward once the screws have been unscrewed. This will disconnect the power supply from the backplane. Pull it completely free of the chassis.
6. Place the power supply in an anti-static bag for storage.
7. Insert a new supply, or place and screw in a cover plate over the empty power supply. Refer to [Installing a DC power supply](#) on page 86 for details.

Installing a DC power supply



DANGER

Before beginning the installation, refer to the precautions in [Installing a DC power supply](#).

Use the following procedures for DC power supplies in Brocade devices.

Follow the steps given below to install an DC power supply.

1. If necessary, remove the power supply locking screws located in the upper left and the bottom right of the device.
2. If the empty power supply bay has a cover plate, remove the two screws near the edges of the cover plate to unlock the plate, then remove the plate.
3. Remove the DC power supply from its packaging ([Installing a DC power supply](#)).

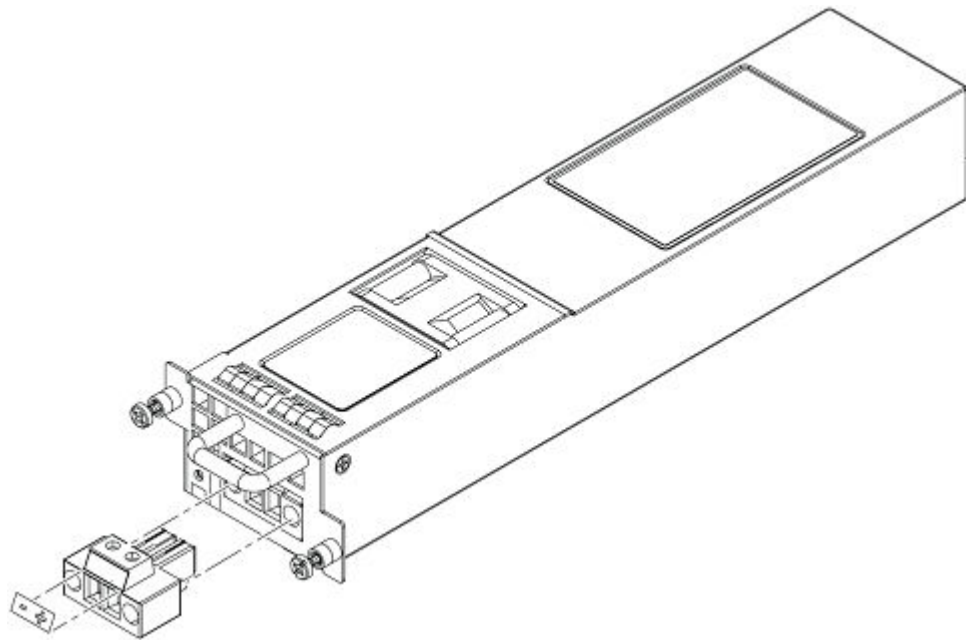
FIGURE 54 The DC power supply

4. Insert the wires into the DC wiring assembly ([Installing a DC power supply](#)).
5. Use the wire tightening screws to secure the wires.
6. Insert the DC connector with wires to the power supply and tighten the two assembly screws.

FIGURE 55 The DC wiring assembly

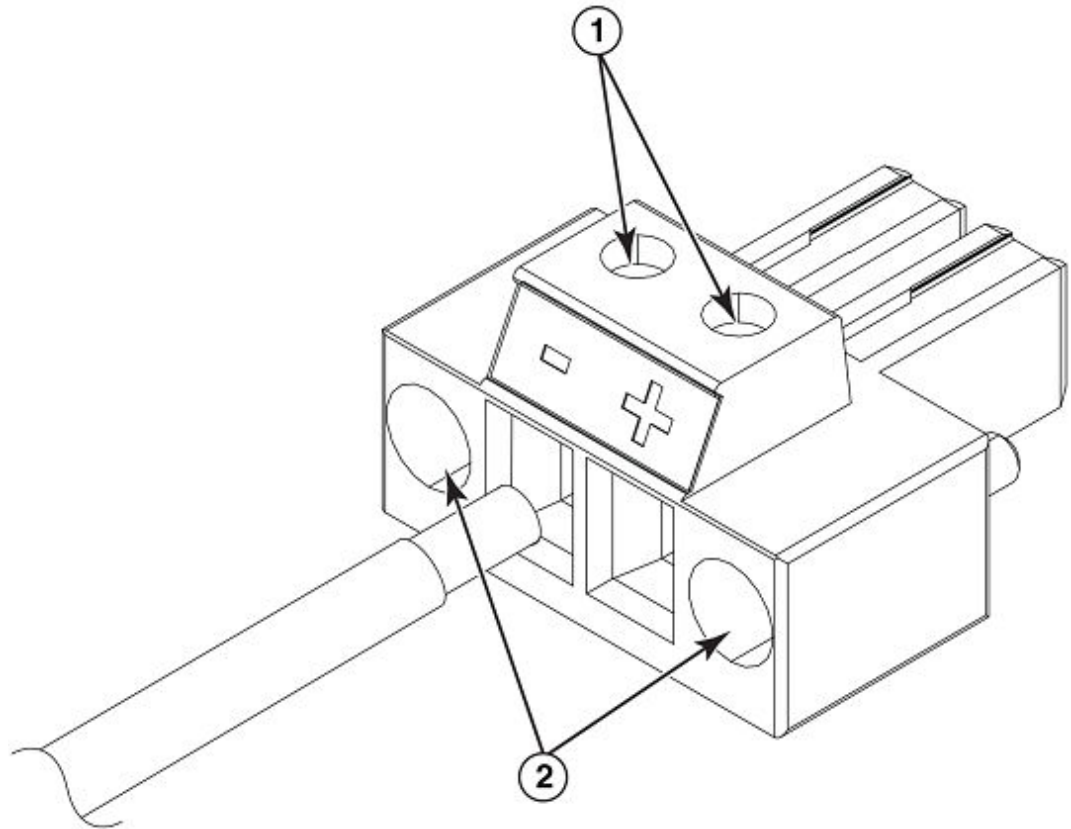

1 Wire tightening screws

2 Assembly screws

7. With one hand, hold the bar on the front panel of the power supply. With the other hand, support the underside of the power supply, and insert the power supply into the empty power supply slot. Press until the supply is completely in the slot, so that the connectors on the back of the supply are fully engaged with the pins on the power backplane ([Installing the AC power supply](#) on page 83).



CAUTION

Carefully follow the mechanical guides on each side of the power supply slot and make sure the power supply is properly inserted in the guides. Never insert the power supply upside down.

8. Secure the two screws near the edges of the supply to lock the supply in place ([Installing a DC power supply](#)).

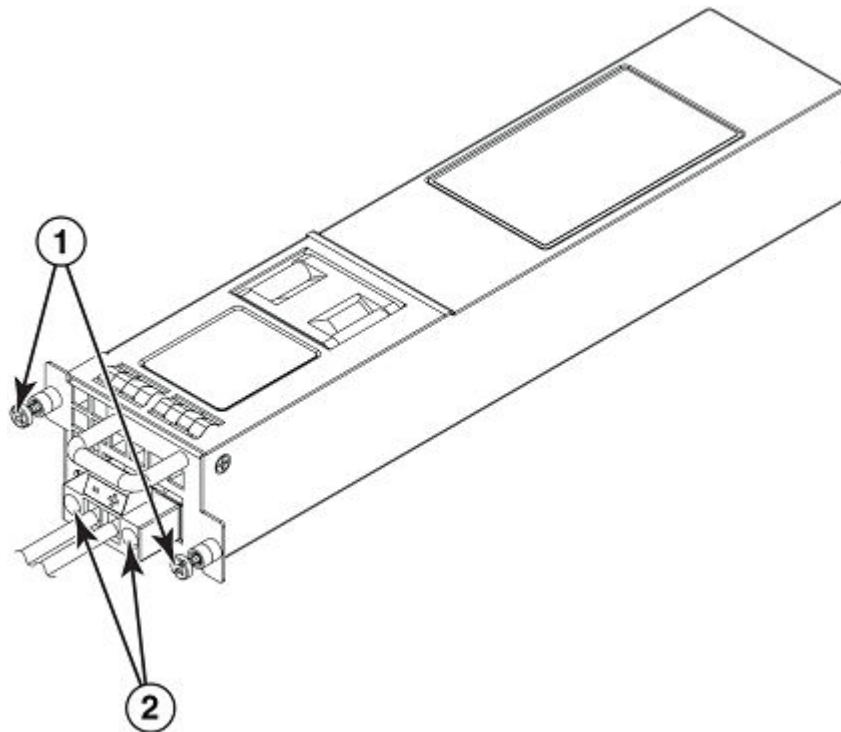
FIGURE 56 DC power supply screws

 1 Chassis attachment screws

 2 Assembly screws

9. Connect the wire to your DC power source, making sure to connect the -48V cable to the negative terminal on the power supply and the 0V cable to the positive terminal as marked on the power supply.

The equipment installation must meet NEC/CEC code requirements. Consult local authorities for regulations.

NOTE

Ensure that the DC return is isolated from the chassis ground (DC-I) when connections to the power supply are made.

**CAUTION**

For a DC system, use a grounding wire of at least 6 American Wire Gauge (AWG). The 6 AWG wire should be attached to an agency-approved crimp connector crimped with the proper tool. The crimp connector should allow for securement to both ground screws on the enclosure. For the Ground lug, use UL listed Panduit crimp connector, P/N LCD6-10A, and two 10-32, PPH, screws to secure crimp connector to chassis. Grounding position is located on the side of the chassis adjacent ground symbol.

NOTE

To ensure adequate bonding when attaching the provided Panduit LCD6-10AF two-hole ground lug, a minimum of 20 PSI of torque is required to be applied to the mounting hardware used to attach the ground lug. Use a star washer to ensure an NEBS compliant connection.

Verifying proper operation

To verify the proper operation of the power supply after power on, you can observe the LEDs on the power supply.

After the Brocade device powers on, you can observe the LEDs on the front of the device to verify that it initialized successfully. There is a single LED on the power supply which should be steady green when the power supply is receiving power and under normal operation. Table 1 outlines the LEDs, the desired state of each LED, possible abnormal states of each LED, and what to do if an LED indicates an abnormal state.

To verify proper operation, complete the following steps.

1. Verify that the power supply's LED is steady green on the back of the device.
2. Verify that the power supply was placed in power supply bay #1 and operational by observing a steady green LED lighting up "P1" on the front of the device.

TABLE 19 LEDs for power and fans (located on front of device)

LED	State	Meaning
Fan (labeled Fn)	On	The fan tray is powered on and is operating normal.
	Off	The fan tray is not powered on, or has been removed.
PS1 (labeled P1)	Off	Power supply 1 is not installed or is not providing power.
	Amber	Power supply 1 is installed, but not connected or a fault is detected.
	Green Steady	Power supply 1 is installed and is functioning normally.
	Green Blinking	Power supply 1 has input power, but is not enabled and has no output power.
PS2 (labeled P2)	Off	Power supply 2 is not installed or is not providing power.
	Amber	Power supply 2 is installed, but not connected or a fault is detected.
	Green Steady	Power supply 2 is installed and is functioning normally.
	Green Blinking	Power supply 2 has input power, but is not enabled and has no output power.

The LEDs for Fan, PS1 and PS2 are located on the right side of the front panel for Brocade NetIron CES Series and Brocade NetIron CER Series 2024 models (On the Brocade NetIron CES Series 2048 and Brocade NetIron CER Series 2048 models, these LEDs are located on the left side of the front panel).

The software regularly polls the hardware for power status information. You can display the status information from any management session. In addition, the software automatically generates a Syslog message and SNMP trap if a status change occurs.

Displaying the status of the power supplies

You can display the status of the power supplies by entering the **show chassis** command at any level of the CLI. The display shows whether a power supply is installed in the specified power supply slot

and the status of the power supply. If you are not already attached to a terminal or a PC running terminal emulation, see [Displaying the status of the power supplies](#)

```
device> show chassis
*** Brocade NetIron CES Series 2048CX ***
---POWERS ---
Power 1 ( 3I50      - AC 504W): Installed (OK)
Power 2: not present
Total power budget for system = 504 W
--- FANS ---
Metro fan tray (fan 1): Status = OK, Speed = LOW (50%)
Metro fan tray (fan 2): Status = OK, Speed = LOW (50%)
Metro fan tray (fan 3): Status = OK, Speed = LOW (50%)
Metro fan tray (fan 4): Status = OK, Speed = LOW (50%)
Metro fan tray (fan 5): Status = OK, Speed = LOW (50%)
Metro fan tray (fan 6): Status = OK, Speed = LOW (50%)
--- TEMPERATURE READINGS ---
CPU: Board 32.50C Chip 41.6C
481XG PPCR1: Board 32.50C Chip 43.31C
481XG PPCR2: Board 29.50C Chip 41.93C
2X10G PPCR: Board 33.0C Chip 41.68C
Fans are in auto mode. Temperature Monitoring Poll Period is 60 seconds
Base MAC Address = 001b.ed39.0300
Brocade NetIron CES Series 2048CX>
```

Syntax: show chassis

10-Gigabit Ethernet module installation or replacement

The 2-port 10-Gigabit Ethernet modules may optionally be installed or replaced in the field on the Brocade NetIron CES Series 2024C, Brocade NetIron CES Series 2024F, Brocade NetIron CER Series 2024C, Brocade NetIron CER Series 2024F units. You can order the Brocade `device` with a 2 x10-Gigabit module installed at the factory, or you can upgrade your device later.

This section provides the steps for installing, removing, and replacing the 10-Gigabit Ethernet module. You will need the following tools to perform these procedures:

- #2 Phillips-head screwdriver
- Electrostatic Discharge (ESD) kit



DANGER

For safety reasons, the ESD wrist strap should contain a series 1 megaohm resistor.

Removing a 2 x10-Gigabit Ethernet module

Follow the procedure given below while removing a 2 x10-Gigabit Ethernet module.

1. Power off the Brocade device.
2. Use a #2 Phillips-head screwdriver to loosen the screws on the 2 x10-Gigabit module.
3. Remove the 2 x10-Gigabit module.
4. Place the 2 x10-Gigabit module in an anti-static bag for storage.
5. If you are removing the module without replacing it, install the blank faceplate in the front panel.

Installing a 2 x10-Gigabit Ethernet Module

Follow these procedures when installing a 10-Gigabit Ethernet Module.

1. Power off the Brocade device.
2. Use a #2 Phillips-head screwdriver to remove the blank faceplate or old module from the front panel.
3. Install the 10-Gigabit module in the chassis.
4. Use a #2 Phillips-head screwdriver to fasten the screws on the 2 x10-Gigabit module. Affix the screws loosely at first, then tighten them once you are sure the board is properly positioned.

Replacing the fan tray

The Brocade devices cooling fans use pull configuration to move the air from the front to the back of the device.

The fans in the Brocade devices include six four-speed fans that operate at low speed, medium speed, medium-high speed, and high speed based on the ambient temperature and configured or default temperature thresholds. All fans operate simultaneously at the same speed. If a single fan fails within the assembly, the fan tray should be replaced. The fan tray is hot swappable.

If a Brocade device remains operational during a fan tray replacement, the procedure must be completed within 30 seconds.

NOTE

Fan trays are hot swappable. Hot swapping fan trays should be done within 30 seconds so the unit will continue to function correctly without any fans. However, Brocade recommends that you disconnect the power supply from AC or DC power before installing or removing the fan tray.

To replace the Brocade fan tray, follow these steps.

1. Power down and unplug the chassis.
2. Unscrew the two screws that secure the fan tray to the chassis.

FIGURE 57 Replacing the fan tray

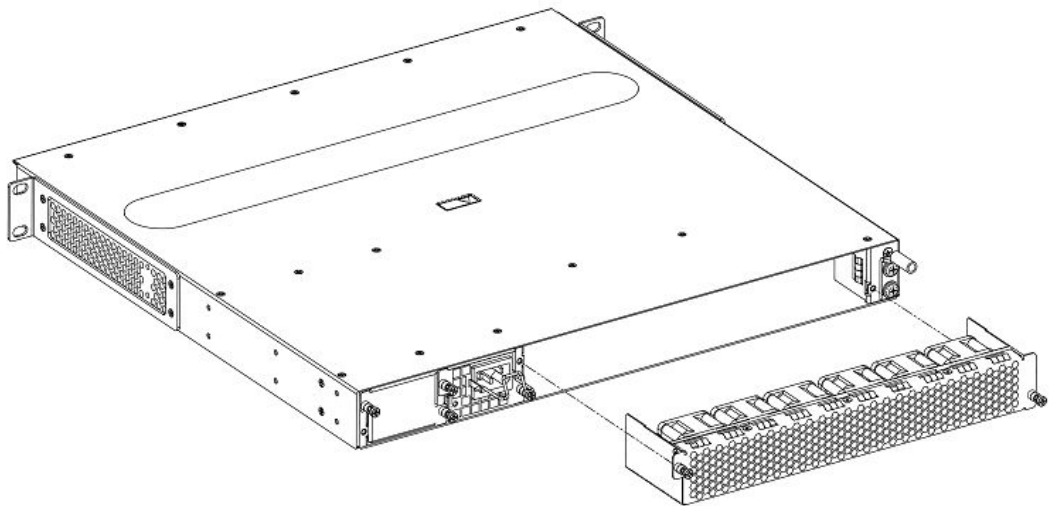

3. Slide the fan tray out

4. Slide the new fan tray in and tighten the screws to secure it to the chassis.
5. Plug the chassis back in and power up.

Copper or Fiber optic module replacement

You can remove an SFP, SFP+, or XFP from a port and replace it with a new one while the Brocade device is powered on and running.

This section provides information about the following tasks:

- Removing a copper or fiber optic module
- Installing a new copper or fiber optic module
- Cabling a fiber optic module

Removing a Copper or fiber optic module

You can remove a copper or fiber SFP (also called a mini-GBIC), SFP+, or an XFP from a port while the Brocade device is powered on and running.

Before removing a copper or fiber optic module, have the following on hand:

- An ESD wrist strap with a plug for connection to the ESD connector on the Stackable device.



DANGER

For safety reasons, the ESD wrist strap should contain a series 1 megaohm resistor.

- The protective covering that you removed from the copper or fiber optic module when you initially installed the module.

Follow the steps given below to remove a copper or fiber optic module from a Gigabit Ethernet or 10-Gigabit Ethernet port.

1. Put on the ESD wrist strap and ground yourself by attaching the clip end to a metal surface (such as an equipment rack).
2. Disconnect the copper or fiber cable connector from the port connector.
3. Insert the protective covering into the port connectors.

FIGURE 58 Pull the copper or fiber optic module out of the port by pulling the bail latch forward, away from the front panel of the module. This unlocks the module from the front panel. On 1000BaseSX ports, the bail latch is enclosed in a black sleeve, and on 1000BaseLX ports, the bail latch is enclosed in a blue sleeve.

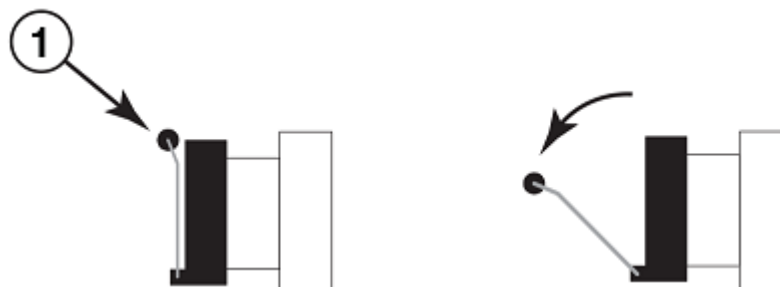

1 Bail latch

NOTE

The bail latch may be attached to either the top or the bottom of the mini-GBIC.

FIGURE 59 Grasping the bail latch, pull the copper or fiber optic module out of the port.

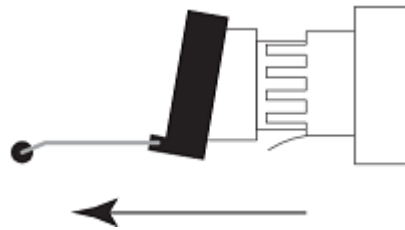

4. Store the copper or fiber optic module in a safe, static-free place or in an anti-static bag.
5. Install a new copper or fiber optic module in the port. For information about performing this task, refer to [Installing a new Copper or fiber optic module](#) on page 94.

Installing a new Copper or fiber optic module

You must install a fiber optic module (SFP, SFP+, or XFP transceiver) in each Gigabit Ethernet and 10-Gigabit Ethernet fiber port you want to use.

You can install a new fiber optic module in a port while the device is powered on and running.

Before installing one of these modules into the port, obtain an ESD wrist strap with a plug for connection to a metal surface.



DANGER

All fiber-optic interfaces use Class 1 lasers.



DANGER

For safety reasons, the ESD wrist strap should contain a series 1 megaohm resistor.

Perform the following tasks to install a fiber optic module.

1. Put on the ESD wrist strap and ground yourself by attaching the clip end to a metal surface (such as an equipment rack) to act as ground.
2. Remove the new module from its protective packaging.
3. Gently insert the fiber optic module into the port until the module clicks into place. The module is keyed to prevent incorrect insertion.

Cabling a fiber optic module

Follow the steps given below to cable a fiber optic module

1. Remove the protective covering from the fiber-optic port connectors and store the covering for future use.
2. Before cabling a fiber optic module, Brocade strongly recommends cleaning the cable connectors and the port connectors. Refer to [Fiber optic connector cleaning](#) on page 95.

3. Gently insert the cable connectors (a tab on each connector should face upward) into the port connectors until the tabs lock into place.
4. Observe the link and active LEDs to determine if the network connections are functioning properly.

**DANGER**

The intra-building port or ports of the equipment or subassembly is suitable for connection to intra-building or unexposed wiring or cabling only. The intra-building port or ports of the equipment or subassembly MUST NOT be metallically connected to interfaces that connect to the outside plant (OSP) or its wiring. These interfaces are designed for use as intra-building interfaces only (Type 2 or Type 4 ports as described in GR-1089-CORE, Issue 5) and require isolation from the exposed OSP cabling. The addition of Primary Protectors is not sufficient protection in order to connect these interfaces metallically to OSP wiring.

Tunable 10 GbE DWDM SFP+

NOTE

Tunable 10 GbE DWDM SFP+ are only supported on NetIron CES and NetIron CER 4x10G models only.

The tunable 10 GbE dense wavelength-division multiplexing (DWDM) SFP+ modular optic (part number 10G-SFPP-ZRD-T) can be configured through the CLI to use C-band channels 1 - 102 for flexible metro or campus Ethernet links that reach up to 80 km.

For 10-Gigabit Ethernet DWDM interfaces only, configure full C-band tunable optics as shown below.

To configure a physical port, enter a command such as the following.

```
device(config-if-e10000-1/1)# tunable-optic sfpp channel 5
```

Syntax: tunable-optic sfpp channel channel number [show]

To configure a LAG port, enter a command such as the following.

```
device(config-if-e10000-1/1)# physical-port 1/1 tunable-optic sfpp channel 5
device(config-lag-lag1)# physical-port 1/1 tunable-optic sfpp channel 5 show
Channel 5: 191.3THz, 1567.13nm
```

Syntax: physical-port port tunable-optic sfpp channel channel number [show]

Use the *channel number* parameter to specify the channel number to use on the interface. Possible values 0 through 102.

Use the **show** options to display the SFPP channel used on the interface.

Fiber optic connector cleaning

To avoid problems with the connection between the fiber optic module (SFP (mini-GBIC), SFP+, or XFP) and the fiber cable connectors, Brocade strongly recommends cleaning both connectors each time you disconnect and reconnect them. In particular, dust can accumulate in the connectors and cause problems such as reducing the optic launch power.

To clean the fiber cable connectors, Brocade recommends using the fiber-optic reel-type cleaner that shipped with your device. You can also purchase this type of cleaner from the following web site.

<http://www.fisfiber.com/>

When not using an SFP, SFP+, or XFP connector, make sure to keep the protective covering on.

Regulatory Statements

- BSMI statement (Taiwan).....97
- Canadian requirements.....97
- China CC statement.....98
- Europe and Australia (CISPR 22 Class A Warning).....98
- FCC warning (US only).....99
- Germany.....99
- KCC statement (Republic of Korea).....99
- VCCI statement.....99

BSMI statement (Taiwan)

警告使用者：
這是甲類的資訊產品，在居住的環境中使用時，可能會造成射頻干擾，
在這種情況下，使用者會被要求採取某些適當的對策。

Warning:

This is Class A product. In a domestic environment this product may cause radio interference in which case the user may be required to take adequate measures.

Canadian requirements

This Class A digital apparatus meets all requirements of the Canadian Interference-Causing Equipment Regulations, ICES-003 Class A.

Cet appareil numérique de la classe A est conforme à la norme NMB-003 du Canada.

China CC statement

 China-CCC Warning statements

在维修的时候一定要断开所有电源 (English translation "disconnect all power sources before service")

 For non tropical use:

安全 说明 和标 记	汉文	“仅适用于非热带气候条件下安全使用。”
	藏文	《འགྲོལ་ལྷན་ཁང་གི་ཁྲིམས་འགྲུབ་ལྟར་དུ་འཇུག་པའི་འཇམ་མཁའ་ལྷན་ཁང་གི་ཁྲིམས་འགྲུབ་།》
	蒙古文	“ཚ་བའི་ས་ཁྲུལ་གྱི་གནས་གཤིས་མིན་པའི་ས་ཁྲུལ་ལོ་ནར་ཉེན་མེད་བྱེད་བྱས་འདུག།”
	社文	Dan hab yungh youq gij dienheiq diuzgen mbouj dwg diegndat haenx ancienz sawjyungh.
	维文	غەبىرى ئىسسىق بەلباغ ھاۋا كىلىماتى ئارائىتىدىلا بىخەتەر ئىشلەتكىلى بولىدۇ

 For altitude 2000 meter and below:

安全 说明 和标 记	汉文	仅适用于海拔2000m以下地区安全使用。
	藏文	《2000m རུང་ལྷན་ཁང་གི་ཁྲིམས་འགྲུབ་ལྟར་དུ་འཇུག་པའི་འཇམ་མཁའ་ལྷན་ཁང་གི་ཁྲིམས་འགྲུབ་།》
	蒙古文	“2000м-ийн дотоод талд хэрэглэхэд зориулсан хэрэгсэл юм. 2000м-ийн дотоод талд хэрэглэхэд зориулсан хэрэгсэл юм.”
	社文	Dan hab yungh youq gij digih hajbaz 2000m doxroengz haenx ancienz sawjyungh.
	维文	دېڭىز يۈزىدىن 2000 مېتر تۆۋەن رايونلاردا بىخەتەر ئىشلەتكىلى بولىدۇ

Warning for Class A:

声 明

此为 A 级产品，在生活环境中，该产品可能会造成无线电干扰。在这种情况下，可能需要用户对其干扰采取切实可行的措施。

English translation of above statement
This is a Class A product. In a domestic environment this product may cause radio interference, in which case the user may be required to take adequate measures.

Europe and Australia (CISPR 22 Class A Warning)

This is a Class A product. In a domestic environment this product may cause radio interference in which case the user may be required to take adequate measures.

FCC warning (US only)

This equipment has been tested and complies with the limits for a Class A computing device pursuant to Part 15 of the FCC Rules. These limits are designed to provide reasonable protection against harmful interference when the equipment is operated in a commercial environment.

This equipment generates, uses, and can radiate radio frequency energy, and if not installed and used in accordance with the instruction manual, might cause harmful interference to radio communications. Operation of this equipment in a residential area is likely to cause harmful interference, in which case the user will be required to correct the interference at the user's own expense.

Germany

Machine noise information regulation - 3. GPSGV, the highest sound pressure level value is 60.0 dB(A) in accordance with EN ISO 7779.

Maschinenlärminformations-Verordnung - 3. GPSGV, der höchste Schalldruckpegel beträgt 60.0 dB(A) gemäss EN ISO 7779.

KCC statement (Republic of Korea)

A급 기기 (업무용 방송통신기기): 이 기기는 업무용(A급)으로 전자파적합등록을 한 기기이오니 판매자 또는 사용자는 이 점을 주의하시기 바라며, 가정외의 지역에서 사용하는 것을 목적으로 합니다.

Class A device (Broadcasting Communication Device for Office Use): This device obtained EMC registration for office use (Class A), and may be used in places other than home. Sellers and/or users need to take note of this.

VCCI statement

この装置は、クラスA情報技術装置です。この装置を家庭環境で使用すると電波妨害を引き起こすことがあります。この場合には使用者が適切な対策を講ずるよう要求されることがあります。 VCCI-A

This is a Class A product based on the standard of the Voluntary Control Council for Interference by Information Technology Equipment (VCCI). If this equipment is used in a domestic environment, radio disturbance might arise. When such trouble occurs, the user might be required to take corrective actions.

Caution and Danger Notices

- [Cautions](#)..... 101
- [Danger Notices](#)..... 108

The caution and danger notices that appear in this manual are listed below in English, German, French, and Spanish.

Cautions

A Caution statement alerts you to situations that can be potentially hazardous to you or cause damage to hardware, firmware, software, or data.

Ein Vorsichtinweis warnt Sie vor potenziellen Personengefahren oder Beschädigung der Hardware, Firmware, Software oder auch vor einem möglichen Datenverlust

Un message de mise en garde vous alerte sur des situations pouvant présenter un risque potentiel de dommages corporels ou de dommages matériels, logiciels ou de perte de données.

Un mensaje de precaución le alerta de situaciones que pueden resultar peligrosas para usted o causar daños en el hardware, el firmware, el software o los datos.

General cautions



CAUTION

Do not install the device in an environment where the operating ambient temperature might exceed 40°C (104°F).

VORSICHT	Das Gerät darf nicht in einer Umgebung mit einer Umgebungsbetriebstemperatur von über 40°C (104°F) installiert werden.
----------	--

MISE EN GARDE	N'installez pas le dispositif dans un environnement où la température d'exploitation ambiante risque de dépasser 40°C (104°F).
---------------	--

PRECAUCIÓN	No instale el instrumento en un entorno en el que la temperatura ambiente de operación pueda exceder los 40°C (104°F).
------------	--



CAUTION

Make sure the airflow around the front, sides, and back of the device is not restricted.

VORSICHT	Stellen Sie sicher, dass an der Vorderseite, den Seiten und an der Rückseite der Luftstrom nicht behindert wird.
----------	--

MISE EN GARDE	Vérifiez que rien ne restreint la circulation d'air devant, derrière et sur les côtés du dispositif et qu'elle peut se faire librement.
---------------	---

PRECAUCIÓN Asegúrese de que el flujo de aire en las inmediaciones de las partes anterior, laterales y posterior del instrumento no esté restringido.



CAUTION

Never leave tools inside the chassis.

VORSICHT Lassen Sie keine Werkzeuge im Chassis zurück.

MISE EN GARDE Ne laissez jamais d'outils à l'intérieur du châssis

PRECAUCIÓN No deje nunca herramientas en el interior del chasis.



CAUTION

Changes or modifications made to this device that are not expressly approved by the party responsible for compliance could void the user's authority to operate the equipment.

VORSICHT Falls dieses Gerät verändert oder modifiziert wird, ohne die ausdrückliche Genehmigung der für die Einhaltung der Anforderungen verantwortlichen Partei einzuholen, kann dem Benutzer der weitere Betrieb des Gerätes untersagt werden.

MISE EN GARDE Les éventuelles modifications apportées à cet équipement sans avoir été expressément approuvées par la partie responsable d'en évaluer la conformité sont susceptibles d'annuler le droit de l'utilisateur à utiliser cet équipement.

PRECAUCIÓN Si se realizan cambios o modificaciones en este dispositivo sin la autorización expresa de la parte responsable del cumplimiento de las normas, la licencia del usuario para operar este equipo puede quedar anulada.



CAUTION

Use the erase startup-config command only for new systems. If you enter this command on a system you have already configured, the command erases the configuration. If you accidentally do erase the configuration on a configured system, enter the write memory command to save the running configuration to the startup-config file.

VORSICHT Verwenden Sie den Befehl **Erase startup-config** (Löschen Startup-Konfig) nur für neue Systeme. Wenn Sie diesen Befehl in ein bereits konfiguriertes System eingeben, löscht der Befehl die Konfiguration. Falls Sie aus Versehen die Konfiguration eines bereits konfigurierten Systems löschen, geben Sie den Befehl **Write Memory** (Speicher schreiben) ein, um die laufende Konfiguration in der Startup-Konfig-Datei zu speichern.

MISE EN GARDE N'utilisez la commande **erase startup-config** que pour les nouveaux systèmes. Si vous entrez cette commande sur un système que vous avez déjà configuré, elle efface la configuration. Si vous effacez la configuration par accident sur un système configuré, entrez la commande **write memory** pour enregistrer la configuration actuelle dans le fichier startup-config.

PRECAUCIÓN Use el comando **erase startup-config** (borrar configuración de inicio) para sistemas nuevos solamente. Si usted introduce este comando en un sistema que ya ha configurado, el comando borrará la configuración. Si usted borra accidentalmente la configuración en un sistema ya configurado, introduzca el comando **write memory** (escribir memoria) para guardar la configuración en ejecución en el archivo startup-config.

Electrical cautions



CAUTION

Use a separate branch circuit for each power cord, which provides redundancy in case one of the circuits fails.

VORSICHT Es empfiehlt sich die Installation eines separaten Stromkreisweiges für jede Elektroschnur als Redundanz im Fall des Ausfalls eines Stromkreises.

MISE EN GARDE Utilisez un circuit de dérivation différent pour chaque cordon d'alimentation ainsi, il y aura un circuit redondant en cas de panne d'un des circuits.

PRECAUCIÓN Use un circuito derivado separado para cada cordón de alimentación, con lo que se proporcionará redundancia en caso de que uno de los circuitos falle.



CAUTION

Ensure that the device does not overload the power circuits, wiring, and over-current protection. To determine the possibility of overloading the supply circuits, add the ampere (amp) ratings of all devices installed on the same circuit as the device. Compare this total with the rating limit for the circuit. The maximum ampere ratings are usually printed on the devices near the input power connectors.

VORSICHT Stromkreise, Verdrahtung und Überlastschutz dürfen nicht durch das Gerät überbelastet werden. Addieren Sie die Nennstromleistung (in Ampere) aller Geräte, die am selben Stromkreis wie das Gerät installiert sind. Somit können Sie feststellen, ob die Gefahr einer Überbelastung der Versorgungsstromkreise vorliegt. Vergleichen Sie diese Summe mit der Nennstromgrenze des Stromkreises. Die Höchstnennströme (in Ampere) stehen normalerweise auf der Geräterückseite neben den Eingangsstromanschlüssen.

MISE EN GARDE Assurez-vous que le dispositif ne risque pas de surcharger les circuits d'alimentation, le câblage et la protection de surintensité. Pour déterminer le risque de surcharge des circuits d'alimentation, additionnez l'intensité nominale (ampères) de tous les dispositifs installés sur le même circuit que le dispositif en question. Comparez alors ce total avec la limite de charge du circuit. L'intensité nominale maximum en ampères est généralement imprimée sur chaque dispositif près des connecteurs d'entrée d'alimentation.

PRECAUCIÓN Verifique que el instrumento no sobrecargue los circuitos de corriente, el cableado y la protección para sobrecargas. Para determinar la posibilidad de sobrecarga en los circuitos de suministros, añada las capacidades nominales de corriente (amp) de todos los instrumentos instalados en el mismo circuito que el instrumento. Compare esta suma con el límite nominal para el circuito. Las capacidades nominales de corriente máximas están generalmente impresas en los instrumentos, cerca de los conectores de corriente de entrada.



CAUTION

Before plugging a cable into to any port, be sure to discharge the voltage stored on the cable by touching the electrical contacts to ground surface.

VORSICHT Bevor Sie ein Kabel in einen Anschluss einstecken, entladen Sie jegliche im Kabel vorhandene elektrische Spannung, indem Sie mit den elektrischen Kontakten eine geerdete Oberfläche berühren.

MISE EN GARDE Avant de brancher un câble à un port, assurez-vous de décharger la tension du câble en reliant les contacts électriques à la terre.

PRECAUCIÓN Antes de conectar un cable en cualquier puerto, asegúrese de descargar la tensión acumulada en el cable tocando la superficie de conexión a tierra con los contactos eléctricos.



CAUTION

All devices with DC power supplies are intended for installation in restricted access areas only. A restricted access area is where access can be gained only by service personnel through the use of a special tool, lock and key, or other means of security, and is controlled by the authority responsible for the location.

VORSICHT Alle Geräte mit DC-Netzteil sind nur für die Installation in Bereichen mit beschränktem Zugang gedacht. Ein Bereich mit beschränktem Zugang ist ein Bereich, zu dem nur Wartungspersonal mit Spezialwerkzeug, Schlüssel oder anderen Sicherheitsvorrichtungen Zugang hat. Dieser Zugang wird von für den Bereich zuständigen Personen überwacht.

MISE EN GARDE Tous les dispositifs avec bloc d'alimentation C.C. sont conçus pour l'installation dans des zones à accès réglementé uniquement. Une zone à accès réglementé est une zone dont l'accès n'est possible qu'au personnel de service utilisant un verrou, une clé ou un outil spécial, ou d'autres moyens de sécurité, et qui est contrôlée par les autorités responsables du site.

PRECAUCIÓN Todos los instrumentos con suministros de corriente continua han sido diseñados únicamente para instalación en áreas restringidas. Se entiende como área de acceso restringido un lugar al que solo puede acceder personal de servicio mediante el uso de una herramienta especial, llave y cerrojo u otro medio de seguridad similar, y que esté controlado por la autoridad responsable de esa ubicación.



CAUTION

All devices with AC power sources are intended for installation in restricted access areas only. A restricted access area is a location where access can be gained only by service personnel through the use of a special tool, lock and key, or other means of security.

VORSICHT Alle Geräte mit Wechselstromquellen sind nur zur Installation in Sperrbereichen bestimmt. Ein Sperrbereich ist ein Ort, zu dem nur Wartungspersonal mit einem Spezialwerkzeug, Schloss und Schlüssel oder einer anderen Schutzvorrichtung Zugang hat.

MISE EN GARDE	Tous les équipements dotés de sources d'alimentation électrique secteur sont destinés à être installés uniquement dans des zones à accès réglementé. Une zone à accès réglementé est une zone dont l'accès n'est possible qu'au personnel de service utilisant un verrou, une clé ou un outil spécial, ou d'autres moyens de sécurité.
---------------	--

PRECAUCIÓN	Todos aquellos dispositivos con fuentes de alimentación de CA están diseñados para su instalación en zonas de acceso restringido solamente. Una zona de acceso restringido es un lugar al que sólo puede acceder personal de mantenimiento haciendo uso de una herramienta especial, una llave y un candado, o algún otro medio de seguridad.
------------	---

**CAUTION**

Remove the power cord from a power supply before you install it in or remove it from the device. Otherwise, the power supply or the device could be damaged as a result. (The device can be running while a power supply is being installed or removed, but the power supply itself should not be connected to a power source.)

VORSICHT	Nehmen Sie vor dem Anschließen oder Abtrennen des Geräts das Stromkabel vom Netzteil ab. Ansonsten könnten das Netzteil oder das Gerät beschädigt werden. (Das Gerät kann während des Anschließens oder Annehmens des Netzteils laufen. Nur das Netzteil sollte nicht an eine Stromquelle angeschlossen sein.)
----------	--

MISE EN GARDE	Enlevez le cordon d'alimentation d'un bloc d'alimentation avant de l'installer ou de l'enlever du dispositif. Sinon, le bloc d'alimentation ou le dispositif risque d'être endommagé. (Le dispositif peut être en train de fonctionner lorsque vous installez ou enlevez un bloc d'alimentation, mais le bloc d'alimentation lui-même ne doit pas être connecté à une source d'alimentation.)
---------------	---

PRECAUCIÓN	Retire el cordón de corriente del suministro de corriente antes de instalarlo o retirarlo del instrumento. De no hacerse así, el suministro de corriente o el instrumento podrían resultar dañados. (El instrumento puede estar encendido mientras se instala o retira un suministro de corriente, pero el suministro de corriente en sí no deberá conectado a la corriente).
------------	---

**CAUTION**

The power supply is designed exclusively for use with the Brocade NetIron CES Series and Brocade NetIron CER Series devices. The power supply produces extensive power. Installing the power supply in a device other than a NetIron CES Series or NetIron CER Series will cause damage to your equipment.

VORSICHT	Das Netzteil ist ausschließlich für die Verwendung mit den Brocade NetIron CES-Serie und Brocade NetIron CER-Serie Geräte. Das Netzteil liefert hohe Strompegel. Installation der Stromversorgung in einem anderen als einem NetIron CES-Serie oder NetIron CER-Serie-Gerät Schäden an den Geräten führen.
----------	--

MISE EN GARDE	L'alimentation est conçu exclusivement pour une utilisation avec les appareils NetIron CES série et Brocade NetIron CER série. L'alimentation produit un pouvoir étendu. Installation de l'alimentation dans un dispositif autre qu'un CES NetIron ou NetIron CER Series causer des dommages à votre équipement.
---------------	--

PRECAUCIÓN La fuente de alimentación está diseñada exclusivamente para el uso con los dispositivos de Brocade NetIron CES Series y Brocade NetIron CER Series. La fuente de alimentación produce un amplio poder. Instalación de la fuente de alimentación en un dispositivo distinto de la CES Series NetIron o NetIron CER Series causará daños en el equipo.



CAUTION

For the DC input circuit, (DC power supply part number RPS9-DC), make sure there is a 20-amp circuit breaker, minimum -48VDC, double pole, on the input to the terminal block. The input wiring for connection to the product should be copper wire, 12 AWG, marked VW-1, and rated 90 degrees Celsius.

VORSICHT Für den Eingangs-Gleichstromkreis (Gleichstromnetzteile mit der Teilennr. RPS9-DC) muss gewährleistet werden, dass ein 20 A-Leistungsschalter (min. -48VDC) am Eingang zur Reihenklemme installiert wird. Beim Eingangsdraht für den Anschluss am Produkt muss es sich um einen zulässigen Kupferdraht (12 AWG gekennzeichnet mit VW-1), der für mindestens 90° C ausgelegt ist, handeln.

MISE EN GARDE Pour le circuit d'alimentation C.C.(références du bloc d'alimentation C.C. RPS9-DC), assurez-vous de la présence d'un 20 ampères, minimum -48 V C.C., double coupure, sur l'entrée vers le bloc d'alimentation. Les câbles d'alimentation pour le produit doivent être en fils de cuivre, 3.31 mm² (American Wire Gauge), marqués VW-1 et classés 90 degrés Celsius.

PRECAUCIÓN Para el circuito de entrada de CC (suministro de corriente continua con No. de referencia RPS9-DC), verifique que haya un cortacircuitos para 20 amperios, mínimo de -48 VCC, bipolar, en la entrada al bloque terminal. El cableado de entrada para la conexión al producto deberá ser catalogado de cobre, 12 AWG, marcado VW-1, y nominal para 90 grados Celsius.



CAUTION

For a DC system, use a grounding wire of at least 6 American Wire Gauge (AWG). The 6 AWG wire should be attached to an agency-approved crimp connector crimped with the proper tool. The crimp connector should allow for securement to both ground screws on the enclosure. For the Ground lug, use UL listed Panduit crimp connector, P/N LCD6-10A, and two 10-32, PPH, screws to secure crimp connector to chassis. Grounding position is located on the side of the chassis adjacent ground symbol.

VORSICHT Für ein Gleichstromsystem ist ein Erdungsdraht (wenigstens 6 AWG) erforderlich. Ein 6 AWGDraht muss mit dem richtigen Werkzeug an einen zugelassenen Crimpverbinder angebracht werden. Der Crimpverbinder dient der Sicherung beider Erdungsschrauben am Gehäuse. Benutzen Sie einen Panduit-Crimpverbinder, Teile Nr. LCD6-10A, als Erdungskabelschuh und zwei 10-32 PPH-Schrauben zum Anbringen des Crimpverbinder am das Gehäuse. Die Erdungsposition befindet sich auf der Gehäuseseite neben dem Erdungssymbol.

MISE EN GARDE Pour les systèmes C.C., utilisez un fil de mise à la terre d'au moins 6 AWG (American Wire Gauge). Ce fil de 6 AWG doit être relié à un connecteur à sertissage homologué, serti avec l'outil approprié. Le connecteur à sertissage doit permettre la sécurisation aux deux vis de borne de terre sur le boîtier. Pour la patte de mise à la terre, utilisez un connecteur à sertissage UL Panduit, P/N LCD6-10A, et deux vis 10-32, PPH pour attacher le connecteur à sertissage au châssis. La position de mise à la terre se trouve sur le côté du châssis, près du symbole de mise à la terre.

PRECAUCIÓN Para un sistema de CC, utilice un cable de conexión a tierra de calibre de cable norteamericano (AWG) número 6. El cable 6 AWG deberá acoplarse a un conector engarzado aprobado y engarzado con la herramienta apropiada. El conector engarzado deberá permitir el aseguramiento de ambos tornillos de conexión a tierra en el recinto. Para la lengüeta de masa, emplee un conector engarzado Panduit catalogado por UL, No de pieza LCD6-10A, y dos tornillos PPH, 10-32, para fijar el conector engarzado al chasis. La posición de la conexión a tierra está ubicada en el lado del chasis adyacente al símbolo de conexión a tierra.



CAUTION

For a Brocade AC system, use a ground wire of at least 6 American Wire Gauge (AWG). The ground wire should have an agency-approved crimped connector (provided with the chassis) attached to one end, with the other end attached to building ground. The connector must be crimped with the proper tool, allowing it to be connected to both ground screws on the enclosure.

VORSICHT Für ein Brocade Wechselstromsystem ist ein Erdleiter von mindestens 6 AWG (amerikanische Norm für Drahtquerschnitte) zu verwenden. An einem Ende des Erdleiters sollte ein geprüfter gecrimpter Anschluss (mit Chassis bereitgestellt) angebracht sein. Das andere Ende sollte an der Gebäudeerdung angeschlossen werden. Der Anschluss muss mit dem richtigen Werkzeug gecrimpt werden, so dass er an beiden Erdungsschrauben am Gehäuse angeschlossen werden kann.

MISE EN GARDE Pour un système à alimentation secteur Brocade, utiliser un câble de mise à la terre de calibre AWG 6 (13 mm²) minimum. Ce fil de terre doit être équipé d'un côté d'un connecteur à sertir agréé (fourni avec le châssis), et l'autre extrémité doit être reliée à la terre du bâtiment. Ce connecteur doit être serti à l'aide de l'outil approprié afin d'être raccordé aux deux vis de mise à la terre du boîtier.

PRECAUCIÓN Para un sistema de CA Brocade, utilice un conductor de tierra de al menos 6 CAE (Calibre de Alambre Estadounidense, American Wire Gauge o AWG en sus siglas en inglés). El conductor de tierra debe tener un conector rizado homologado (suministrado con el chasis) acoplado a un extremo, y el otro extremo debe estar conectado a la tierra del edificio. El conector debe rizarse con la herramienta apropiada, de manera que se conecte a los dos tornillos de tierra del recinto.



CAUTION

If you do not install a module or a power supply in a slot, you must keep the slot filler panel in place. If you run the chassis with an uncovered slot, the system will overheat.

VORSICHT Falls kein Modul oder Netzteil im Steckplatz installiert wird, muss die Steckplatztafel angebracht werden. Wenn ein Steckplatz nicht abgedeckt wird, läuft das System heiß.

MISE EN GARDE Si vous n'installez pas de module ou de bloc d'alimentation dans un slot, vous devez laisser le panneau du slot en place. Si vous faites fonctionner le châssis avec un slot découvert, le système surchauffera.

PRECAUCIÓN Si no instala un módulo o un fuente de alimentación en la ranura, deberá mantener el panel de ranuras en su lugar. Si pone en funcionamiento el chasis con una ranura descubierta, el sistema sufrirá sobrecalentamiento.



CAUTION

Carefully follow the mechanical guides on each side of the power supply slot and make sure the power supply is properly inserted in the guides. Never insert the power supply upside down.

VORSICHT	Beachten Sie mechanischen Führungen an jeder Seite des Netzteils, das ordnungsgemäß in die Führungen gesteckt werden muss. Das Netzteil darf niemals umgedreht eingesteckt werden.
MISE EN GARDE	Suivez attentivement les repères mécaniques de chaque côté du slot du bloc d'alimentation et assurez-vous que le bloc d'alimentation est bien inséré dans les repères. N'insérez jamais le bloc d'alimentation à l'envers.
PRECAUCIÓN	Siga cuidadosamente las guías mecánicas de cada lado de la ranura del suministro de energía y verifique que el suministro de energía está insertado correctamente en las guías. No inserte nunca el suministro de energía de manera invertida.

Cautions related to equipment weight



CAUTION

To prevent damage to the chassis and components, never attempt to lift the chassis using the fan or power supply handles. These handles were not designed to support the weight of the chassis.

VORSICHT	Alle Geräte mit Wechselstromquellen sind nur zur Installation in Sperrbereichen bestimmt. Ein Sperrbereich ist ein Ort, zu dem nur Wartungspersonal mit einem Spezialwerkzeug, Schloss und Schlüssel oder einer anderen Schutzvorrichtung Zugang hat.
MISE EN GARDE	Pour éviter d'endommager le châssis et les composants, ne jamais tenter de soulever le châssis par les poignées du ventilateur ou de l'alimentation. Ces poignées n'ont pas été conçues pour supporter le poids du châssis.
PRECAUCIÓN	Para prevenir daños al chasis y a los componentes, nunca intente levantar el chasis usando las asas de la fuente de alimentación o del ventilador. Tales asas no han sido diseñadas para soportar el peso del chasis.

Danger Notices

A Danger statement indicates conditions or situations that can be potentially lethal or extremely hazardous to you. Safety labels are also attached directly to products to warn of these conditions or situations.

Ein Gefahrenhinweis warnt vor Bedingungen oder Situationen die tödlich sein können oder Sie extrem gefährden können. Sicherheitsetiketten sind direkt auf den jeweiligen Produkten angebracht um vor diesen Bedingungen und Situationen zu warnen.

Un paragraphe Danger indique des conditions ou des situations potentiellement mortelles ou extrêmement dangereuses. Des labels de sécurité sont posés directement sur le produit et vous avertissent de ces conditions ou situations

Una advertencia de peligro indica condiciones o situaciones que pueden resultar potencialmente letales o extremadamente peligrosas. También habrá etiquetas de seguridad pegadas directamente sobre los productos para advertir de estas condiciones o situaciones.

General dangers



DANGER

The procedures in this manual are for qualified service personnel.

GEFAHR Die Vorgehensweisen in diesem Handbuch sind für qualifiziertes Servicepersonal bestimmt.

DANGER Les procédures décrites dans ce manuel doivent être effectuées par un personnel de maintenance qualifié.

PELIGRO Los procedimientos de este manual deben llevarlos a cabo técnicos cualificados.



DANGER

Be careful not to accidentally insert your fingers into the fan tray while removing it from the chassis. The fan may still be spinning at a high speed.

GEFAHR Die Finger dürfen nicht versehentlich in das Ventilatorblech gesteckt werden, wenn dieses vom Gehäuse abgenommen wird. Der Ventilator kann sich unter Umständen noch mit hoher Geschwindigkeit drehen.

DANGER Faites attention de ne pas accidentellement insérer vos doigts dans le boîtier du ventilateur lorsque vous l'enlevez du châssis. Il est possible que le ventilateur tourne encore à grande vitesse

PELIGRO Procure no insertar los dedos accidentalmente en la bandeja del ventilador cuando esté desmontando el chasis. El ventilador podría estar girando a gran velocidad.

Electrical dangers



DANGER

Before beginning the installation, see the precautions in "Power precautions."

GEFAHR Vor der Installation siehe Vorsichtsmaßnahmen unter "Power Precautions" (Vorsichtsmaßnahmen in Bezug auf elektrische Ablagen).

DANGER Avant de commencer l'installation, consultez les précautions décrites dans "Power Precautions" (Précautions quant à l'alimentation).

PELIGRO Antes de comenzar la instalación, consulte las precauciones en la sección "Power Precautions" (Precauciones sobre corriente).



DANGER

Disconnect the power cord from all power sources to completely remove power from the device.

GEFAHR Ziehen Sie das Stromkabel aus allen Stromquellen, um sicherzustellen, dass dem Gerät kein Strom zugeführt wird.

DANGER Débranchez le cordon d'alimentation de toutes les sources d'alimentation pour couper complètement l'alimentation du dispositif.

PELIGRO Para desconectar completamente la corriente del instrumento, desconecte el cordón de corriente de todas las fuentes de corriente.



DANGER

If the installation requires a different power cord than the one supplied with the device, make sure you use a power cord displaying the mark of the safety agency that defines the regulations for power cords in your country. The mark is your assurance that the power cord can be used safely with the device.

GEFAHR Falls für die Installation ein anderes Stromkabel erforderlich ist (wenn das mit dem Gerät gelieferte Kabel nicht passt), müssen Sie sicherstellen, dass Sie ein Stromkabel mit dem Siegel einer Sicherheitsbehörde verwenden, die für die Zertifizierung von Stromkabeln in Ihrem Land zuständig ist. Das Siegel ist Ihre Garantie, dass das Stromkabel sicher mit Ihrem Gerät verwendet werden kann.

DANGER Si l'installation nécessite un cordon d'alimentation autre que celui fourni avec le dispositif, assurez-vous d'utiliser un cordon d'alimentation portant la marque de l'organisation responsable de la sécurité qui définit les normes et réglementations pour les cordons d'alimentation dans votre pays. Cette marque vous assure que vous pouvez utiliser le cordon d'alimentation avec le dispositif en toute sécurité.

PELIGRO Si la instalación requiere un cordón de corriente distinto al que se ha suministrado con el instrumento, verifique que usa un cordón de corriente que venga con la marca de la agencia de seguridad que defina las regulaciones para cordones de corriente en su país. Esta marca será su garantía de que el cordón de corriente puede ser utilizado con seguridad con el instrumento.



DANGER

For safety reasons, the ESD wrist strap should contain a series 1 megaohm resistor.

GEFAHR Aus Sicherheitsgründen sollte ein EGB-Armband zum Schutz von elektronischen gefährdeten Bauelementen mit einem 1 Megaohm-Reihenwiderstand ausgestattet sein.

DANGER	Pour des raisons de sécurité, la dragonne ESD doit contenir une résistance de série 1 méga ohm.
--------	---

PELIGRO	Por razones de seguridad, la correa de muñeca ESD deberá contener un resistor en serie de 1 mega ohmio.
---------	---

**DANGER**

Risk of explosion if battery is replaced by an incorrect type. Dispose of used batteries according to the instructions.

GEFAHR	Es besteht Explosionsgefahr, wenn ein unzulässiger Batterietyp eingesetzt wird. Verbrauchte Batterien sind entsprechend den geltenden Vorschriften zu entsorgen.
--------	---

DANGER	Risque d'explosion en cas de remplacement de la pile par un modèle incorrect. Débarrassez-vous des piles usagées conformément aux instructions.
--------	--

PELIGRO	Riesgo de explosión si se sustituye la batería por una de tipo incorrecto. Deshágase de las baterías usadas de acuerdo con las instrucciones.
---------	--

**DANGER**

Make sure that the power source circuits are properly grounded, then use the power cord supplied with the device to connect it to the power source.

GEFAHR	Stellen Sie sicher, dass die Stromkreise ordnungsgemäß geerdet sind. Benutzen Sie dann das mit dem Gerät gelieferte Stromkabel, um es an die Stromquelle anzuschließen.
--------	---

DANGER	Vérifiez que les circuits de sources d'alimentation sont bien mis à la terre, puis utilisez le cordon d'alimentation fourni avec le dispositif pour le connecter à la source d'alimentation.
--------	--

PELIGRO	Verifique que circuitos de la fuente de corriente están conectados a tierra correctamente; luego use el cordón de potencia suministrado con el instrumento para conectarlo a la fuente de corriente
---------	---

**DANGER**

Make sure to choose the appropriate circuit device depending on the number of AC power supplies installed in the chassis. The minimum current draw for the system is one AC power supply.

GEFAHR	Je nach Anzahl der Wechselstrom-Netzteile im Gehäuse muss das passende Stromgerät ausgewählt werden. Für die Mindeststromentnahme für das System ist ein Wechselstrom-Netzteil erforderlich.
--------	--

DANGER	Assurez-vous de choisir le dispositif de circuit approprié selon le nombre de blocs d'alimentation C.A. installés dans le châssis. L'appel de courant minimum pour le système est d'un bloc d'alimentation C.A.
--------	---

PELIGRO Verifique que elige el instrumento para circuitos apropiado dependiendo del número de suministros de energía de CC instalados en el chasis. La llamada de corriente mínima para el sistema es de un suministro de energía de CC.



DANGER

The intra-building port or ports of the equipment or subassembly is suitable for connection to intra-building or unexposed wiring or cabling only. The intra-building port or ports of the equipment or subassembly MUST NOT be metallically connected to interfaces that connect to the outside plant (OSP) or its wiring. These interfaces are designed for use as intra-building interfaces only (Type 2 or Type 4 ports as described in GR-1089-CORE, Issue 5) and require isolation from the exposed OSP cabling. The addition of Primary Protectors is not sufficient protection in order to connect these interfaces metallically to OSP wiring.

GEFAHR Die gebäudeinternen Anschlüsse des Geräts bzw. der Unterbaugruppe sind nur zur Verbindung mit gebäudeinternen bzw. nicht freiliegenden Drähten und Kabeln geeignet. Die gebäudeinternen Anschlüsse des Geräts bzw. der Baugruppe DÜRFEN NICHT metallisch mit Schnittstellen verbunden werden, die an Außenbereiche (OSP) oder deren Verdrahtung angeschlossen sind. Diese Schnittstellen sind ausschließlich zur Verwendung als gebäudeinterne Schnittstellen ausgelegt (Anschlüsse des Typs 2 oder 4 gemäß GR-1089-CORE, Ausgabe 5) und müssen von den freiliegenden OSP-Kabeln isoliert werden. Eine hinzugefügte Primärschutzeinrichtung ist kein ausreichender Schutz gegen den metallischen Anschluss dieser Schnittstellen an die OSP-Verdrahtung.

DANGER Le ou les ports réservés à l'utilisation de l'appareil à l'intérieur d'un bâtiment (intra-building) sont uniquement destinés à une connexion en intérieur ou avec du câblage non exposé aux intempéries. Il est rigoureusement interdit d'établir un contact métallique entre le ou les ports réservés à l'utilisation de l'équipement à l'intérieur d'un bâtiment et des interfaces connectées à des installations extérieures(OSP) ou à leur câblage. Ces interfaces sont en effet destinées uniquement à un usage en intérieur (les ports de type 2 ou 4 sont décrits dans le document GR-1089-CORE, volume 5) ; elles doivent être isolées de tout câblage exposé à l'extérieur. L'ajout de dispositifs de protection primaire n'offre pas une protection suffisante pour permettre de raccorder par contact métallique ces interfaces à un câblage ou une installation en extérieur.

PELIGRO Los puertos del equipo o del sistema secundario situados en el interior de un edificio únicamente podrán conectarse a instalaciones eléctricas o cableados que se encuentren dentro del edificio o que no estén expuestos. Los puertos del equipo o del sistema secundario situados en el interior del edificio NO DEBEN conectarse metálicamente a interfaces que se encuentren conectadas a la planta exterior (OSP por sus siglas en inglés) o a su sistema eléctrico. Dichas interfaces han sido diseñadas para uso exclusivo en el interior de un edificio (puertos Tipo 2 o Tipo 4, según lo descrito en GR-1089-CORE, Número 5) y deben aislarse del cableado de la OSP expuesto. La incorporación de Protectores Primarios no proporciona protección suficiente para conectar dichas interfaces metálicamente al sistema eléctrico de la OSP.

Dangers related to equipment weight



DANGER

Make sure the rack housing the device is adequately secured to prevent it from becoming unstable or falling over.

GEFAHR	Stellen Sie sicher, dass das Gestell für die Unterbringung des Geräts auf angemessene Weise gesichert ist, so dass das Gestell oder der Schrank nicht wackeln oder umfallen kann.
DANGER	Vérifiez que le bâti abritant le dispositif est bien fixé afin qu'il ne devienne pas instable ou qu'il ne risque pas de tomber.
PELIGRO	Verifique que el bastidor que alberga el instrumento está asegurado correctamente para evitar que pueda hacerse inestable o que caiga.

**DANGER**

Mount the devices you install in a rack as low as possible. Place the heaviest device at the bottom and progressively place lighter devices above.

GEFAHR	Montieren Sie die Geräte im Gestell so tief wie möglich. Platzieren Sie das schwerste Gerät ganz unten, während leichtere Geräte je nach Gewicht (je schwerer desto tiefer) darüber untergebracht werden.
DANGER	Montez les dispositifs que vous installez dans un bâti aussi bas que possible. Placez le dispositif le plus lourd en bas et le plus léger en haut, en plaçant tous les dispositifs progressivement de bas en haut du plus lourd au plus léger.
PELIGRO	Monte los instrumentos que instale en un bastidor lo más bajos posible. Ponga el instrumento más pesado en la parte inferior y los instrumentos progresivamente más livianos más arriba.

Laser dangers**DANGER**

All fiber-optic interfaces use Class 1 lasers.

GEFAHR	Alle Glasfaser-Schnittstellen verwenden Laser der Klasse 1.
DANGER	Toutes les interfaces en fibres optiques utilisent des lasers de classe 1.
PELIGRO	Todas las interfaces de fibra óptica utilizan láser de clase 1.

Index

- 10/100/1000 ports [31](#)
- 10 Gbps ports [31](#)
- 2x10-gigabit Ethernet module
 - installation [91](#)
 - installing [91](#)
 - removal [91](#)

A

- access
 - CLI [63](#)
- access level
 - CONFIG [37](#)
 - Privileged EXEC [37](#)
- address
 - IP [38](#)
- agency approvals [75](#)
- assigning
 - IP address [38](#)
- assigning an IP address to a loopback interface [40](#)
- assigning an IP address to a management interface [39](#)
- assigning an IP address to an interface [40](#)
- assigning an IP address to a virtual interface [40](#)

B

- BSMI statement (Taiwan) [97](#)

C

- Canadian requirements [97](#)
- cautions, listing [101](#)
- CER models [15](#)
- CES models [15](#)
- CIDR [38](#)
- CLI

- access [63](#)
- access levels [37](#)
- attaching serial cable [61](#)
- command completion [64](#)
- CONFIG Level [37](#)
- line editing [64](#)
- logging on [63](#)
- Privileged EXEC level [37](#)
- scroll control [64](#)
- securing access [37](#)
- combination ports [31](#)
- command
 - disable [41](#)
 - enable [41](#)
 - show chassis [90](#)
 - show interface management 1 [41](#)
 - telnet server [41](#)
- command completion, CLI [64](#)
- command line interface. See CLI [61](#)
- CONFIG Level [37](#)
- connecting to network [41](#)
- connection requirements [43](#)
- connector
 - console [61](#)
- console
 - attaching [61](#)
- console port
 - pin assignments [76](#)
- control features [29](#)
- cooling fans [36](#)
- cooling specifications
 - specifications
 - cooling [75](#)
- CTRL-key line editing commands [64](#)

D

- DB-9 connection [29](#)
- desktop installation [53](#)
- device connection [41](#)
- dimensions, physical [72](#)
- disable command [41](#)

E

- electromagnetic approvals [75](#)
- enable command [41](#)

enable password
assigning [37](#)

F

fan speeds [36](#)

FCC warning (US only) [99](#)

features

- Brocade NetIron CER 2024C [26](#)
- Brocade NetIron CER 2024F [26](#)
- Brocade NetIron CER 2048CX [27](#)
- Brocade NetIron CER 2048F [28](#)
- Brocade NetIron CER 2048FX [28](#)
- Brocade NetIron CES 2048C [24](#)
- Brocade NetIron CES 2048CX [24](#)
- Brocade NetIron CES 2048F [25](#)
- Brocade NetIron CES 2048FX [25](#)
- hardware [22](#)
- management [29](#)
- NetIron CER 2048C [27](#)
- NetIron CES 2024C [22](#), [23](#)
- NetIron CES 2024F [23](#)
- software [21](#)

fiber optic module
installation [94](#)
removal [93](#)

filtering, search and output [65](#)

functionality [15](#)

G

grounding [45](#)

H

hardware

installation [43](#)

hardware maintenance [79](#)

help, online [64](#)

hot swap

redundant power supply [79](#)

I

installation

2x10-gigabit Ethernet module [91](#)

AC power supply [48](#)

cabling [47](#)

DC power supply [50](#), [86](#)

desktop [53](#)

hardware [43](#)

location [47](#)

precautions [45](#)

preparations [47](#)

rack mount [53](#)

redundant power supply [48](#)

tasks [44](#)

Installation

location and clearance [47](#)

installing

fiber optic module [94](#)

installing a 2x10-gigabit Ethernet module [91](#)

interface

assigning an IP address [40](#)

interfaces

enabling and disabling [41](#)

IP

network mask [39](#)

IP address

assigning [38](#)

CIDR notation [38](#)

IronView Network Manager [63](#)

L

LEDs

fan [59](#)

port [29](#)

power status [59](#)

power supply [59](#)

line editing, CLI [64](#)

logging on

CLI [63](#)

loopback interface

assigning an IP address [40](#)

M

maintenance [79](#)

management application

CLI [63](#)

overview [63](#)

management features [29](#)

management interface

assigning an IP address [39](#)

management port

- pin assignments [77](#)
- management port function [41](#)
- models
 - CER [15](#)
 - CES [15](#)

N

- network connection [41](#)
- network interfaces [31](#)
- Network mask [39](#)

O

- online help [64](#)
- operating environment [74](#)
- operation
 - verification [58](#)
- output
 - filtering [65](#)
 - the --More-- prompt [66](#)
- overviews [20](#)

P

- package contents [43](#)
- password
 - assigning [37](#)
- PC
 - attaching [61](#)
- physical dimensions [72](#)
- pin assignments
 - console port [76](#)
 - management port [77](#)
 - serial port [61](#)
- port
 - management [41](#)
- port LEDs [29](#)
- ports
 - 10/100/1000 [31](#)
 - 10 Gbps [31](#)
 - combination (combo) [31](#)
- port specifications, console and management [75](#)
- power cord caution [45](#)
- powering on [57](#)
- power specifications [71](#)
- power status LEDs [59](#)
- power supplies
 - AC [35](#)
 - DC [35](#)
- power supply

- AC installation [48](#)
- DC installation [50, 86](#)
- display status [90](#)
- redundant [48](#)
- replacement [79](#)
- Privileged EXEC level [37](#)
- product overviews [20](#)

R

- rack mount installation [53](#)
- redundant power supplies [34](#)
- removing
 - fiber optic module [93](#)
- removing a 2x10-gigabit Ethernet module [91](#)
- replacing a power supply [79](#)
- requirements
 - serial connection [43](#)

S

- safety agency approvals [75](#)
- scroll control, CLI [64](#)
- search
 - filtering [65](#)
 - special characters [68](#)
- security
 - assigning enable password [37](#)
- serial cable [61](#)
- show chassis command [90](#)
- show commands, filtering output [65](#)
- show interface management command [41](#)
- SNMP
 - connection [63](#)
- software features [21](#)
- special characters, search [68](#)
- specifications
 - console and management ports [75](#)
 - operating environment [74](#)
 - power [71](#)
 - storage environment [74](#)
- SSH connection [63](#)
- status
 - power supply [90](#)
- storage environment [74](#)
- subnet masks [39](#)
- supported optics
 - 100/1000 Ethernet ports [31](#)
 - 10-Gbps Ethernet ports [32](#)
- system
 - unpacking [43](#)
- system power on [57](#)

T

- Telnet connection [63](#)
- telnet server command [41](#)
- Temperature [80](#)
- temperature thresholds [36](#)
- terminal emulation [61](#)

U

- unpacking a system [43](#)
- upgrade packages [21](#)

V

- VCCI statement [99](#)
- verifying operation [58](#)
- virtual interface
 - assigning an IP address [40](#)

W

- warnings, listing [101](#)
- Weight
 - warning [58](#)

X

- XFPs [32](#)