

AP6522 Access Point INSTALLATION GUIDE



MOTOROLA SOLUTIONS and the Stylized M Logo are registered in the US Patent & Trademark Office. © Motorola Solutions, Inc. 2013. All rights reserved.

1.0 Introduction	6
1.1 Document Conventions	6
1.2 Warnings	7
1.3 Site Preparation	7
1.4 Package Contents	7
1.4.1 External Antenna Model Package Content	7
1.4.2 Internal Antenna Model Package Content	7
1.4.3 Features	8
2.0 Hardware Installation	9
2.1 Installation Instructions	9
2.2 Precautions	10
2.3 Access Point Placement	10
2.4 Integrated Antenna Model Wall Mount Instructions	10
2.4.1 Wall Mount Hardware	10
2.4.2 Wall Mount Procedure	11
2.5 Integrated Antenna Model Suspended Ceiling T-Bar Mount	13
2.5.1 Suspended Ceiling T-Bar Mount Procedure	13
2.6 External Antenna Model Wall Mount Instructions	14
2.6.1 Wall Mount Hardware	14
2.6.2 Wall Mount Procedure - New Installation	14
2.6.3 Wall Mount Procedure - Existing Access Point Replacement	14
2.7 External Antenna Model Suspended Ceiling T-Bar Mount	15
2.7.1 Suspended Ceiling T-Bar Mount Procedure - Using Mounting Kit	15
2.7.2 Suspended Ceiling T-Bar Mount Procedure - Using Ceiling Hardware	15
2.8 External Antenna Suspended Ceiling Tile (Plenum) Mount	18
2.8.1 Suspended Ceiling Mount Hardware	18
2.8.2 Suspended Ceiling Mount Procedure	18
2.9 AP6522 External Antenna Model Antenna Options	19
2.10 LED Indicators	21

3.0 Basic Access Point Configuration	23
4.0 Specifications	34
4.1 AP6522 Integrated Antenna Model Electrical Characteristics	34
4.2 AP6522 Integrated Antenna Model Physical Characteristics	34
4.3 AP6522 External Antenna Model Electrical Characteristics	35
4.4 AP6522 External Antenna Model Physical Characteristics	35
4.5 Radio Characteristics	36
5.0 Regulatory Information	37
5.1 Country Approvals	37
5.2 Health and Safety Recommendations	38
5.2.1 Country Selection	38
5.2.2 Frequency of Operation	38
5.3 Health and Safety Recommendations	38
5.3.1 Warnings for Use of Wireless Devices	38
5.3.2 Potentially Hazardous Atmospheres - Fixed Installation	38
5.3.3 Safety in Hospitals	39
5.4 RF Exposure Guidelines	39
5.4.1 Reducing RF Exposure - Use Properly	39
5.4.2 International	39
5.4.3	39
5.4.4 US and Canada	40
5.5 Power Supply	40
5.6 Wireless Devices - Countries	40
5.6.1 Country Selection	40
5.6.2 Operation in the US and Canada	40
5.6.3 Radio Frequency Interference Requirements - FCC	40
5.6.4 Radio Frequency Interference Requirements - Canada	41
5.7 CE Marking and ropean Economic Area (EEA)	41
5.8 Statement of Compliance	42

5.9 Korea Warning Statement for Class B ITE	43
5.10 Other Countries	43
5.11 Waste Electrical and Electronic Equipment (WEEE)	44
5.12 Turkish WEEE Statement of Compliance	45
6.0 Motorola Solutions Support Center	46
7.0 AP6522 Access Point China ROHS Agreement	47

1 Introduction

The AP6522 Access Point, a component of the Motorola Solutions wireless controller system, links wireless 802.11abgn devices to the controller, enabling the growth of your wireless network with a cost effective alternative to standard Access Points. The AP6522 Access Point provides multiple deployment options.

The AP6522 Access Point receives all power and transfers data through the same CAT-5 or better Ethernet cable. An 802.3af Ethernet switch or power supply (specifically rated for the AP6522) is required (Part No. PWRS-14000-148R).

An AP6522 model Access Point uses WiNG 5 software as its onboard operating system. The Access Point's unique WiNG 5 software enables the Access Point to function as either a Virtual Controller AP capable of adopting and managing up to 24 additional AP6522 Access Points, a Standalone Access Point or a Dependent mode Access Point managed by its connected controller.

If new to Motorola Solutions Access Point technology, refer to the *WiNG Access Point System Reference Guide* to familiarize yourself with Access Point technology and the feature set supported by the WiNG operating system. The guide is available, at <http://supportcentral.motorolasolutions.com/support/product/manuals.do>.

The AP6522 Access Point is approved under MODEL: AP-0622.

This document is written for the qualified network device installer.

1.1 Document Conventions

The following graphical alerts are used in this document to indicate notable situations:



NOTE Tips, hints, or special requirements that you should take note of.



CAUTION Care is required. Disregarding a caution can result in data loss or equipment malfunction.



WARNING! Indicates a condition or procedure that could result in personal injury or equipment damage.

1.2 Warnings

- Read all installation instructions and site survey reports, and verify correct equipment installation before connecting the Access Point.
- Remove jewelry and watches before installing this equipment.
- Verify the unit is grounded before connecting it to the power source.
- Verify any device connected to this unit is properly wired and grounded.
- Verify there is adequate ventilation around the device, and that ambient temperatures meet equipment operation specifications.

1.3 Site Preparation

- Consult your site survey and network analysis reports to determine specific equipment placement, power drops, and so on.
- Assign installation responsibility to the appropriate personnel.
- Identify and document where all installed components are located.
- Ensure adequate, dust-free ventilation to all installed equipment.
- Identify and prepare Ethernet and console port connections.
- Verify cable lengths are within the maximum allowable distances for optimal signal transmission.

1.4 Package Contents

An AP6522 Access Point is available in integrated antenna and external antenna models. Contents differ depending on the model ordered.

1.4.1 External Antenna Model Package Contents

- AP6522 access point with external antenna connectors (Plenum Rated)
- 2 customer installed mounting lugs
- 4 mounting lug retaining screws
- AP6522 Installation Guide (*This Guide*)

1.4.2 Internal Antenna Model Package Contents

- AP6522 access point with internal antennas
- AP6522 Installation Guide (*This Guide*)

1.4.3 Features

- 2 RJ-45 connectors, one for 10/100/1000 Ethernet and the other for the serial/console connector
- LED indicators
- Slots for wall mounting
- Clips for mounting on a suspended ceiling T-bar (internal antenna model only) with separately orderable accessories
- Lock port for Kensington® style Security Lock

The AP6522 access point has one RJ-45 connector supporting an 10/100/1000 Ethernet port and accepts 802.3af-compliant power from an external source. The illustration below is of an integrated antenna model.



NOTE When operating in a Gigabit Ethernet environment, CAT-5e or CAT-6 cable is recommended for Gigabit operation.

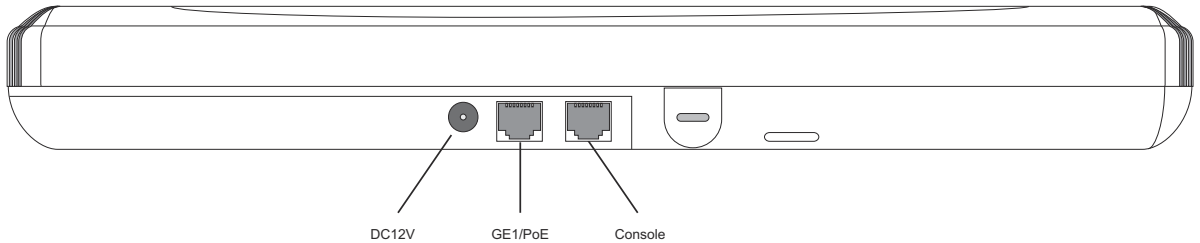

The AP6522 access point comes with dual radios supporting 802.11abgn. The Access Point contains runtime firmware which enables the unit to boot after a power up. The runtime firmware on the Access Point and the firmware downloaded from the connected controller can be updated via the Ethernet interface.

2 Hardware Installation

2.1 Installation Instructions

The AP6522 Access Point mounts either on a wall (with customer supplied M4 x 25 pan head screws and wall anchor - or equivalent) or on a suspended ceiling T-bar. If deploying an external antenna model AP6522 on a suspended ceiling T-bar, Access Point mounting kit (Part No. KT-135628-01) is required. An AP6522 is not designed for mounting on a desk.

To prepare for the installation:

1. Match the model number on the purchase order with the model numbers in the packing list and on the case of the Access Point.
2. Verify the contents of the box include the intended AP6522 Access Point, and the included hardware matches the package contents (see [Package Contents on page 7](#)).

Part Number	Description
AP-6522-66030-US	Dual 802.11n radio AP6522. Plastic enclosure with internal antennas. For use in the US deployments only.
AP-6522-66030-WR	Dual 802.11n radio AP6522. Plastic enclosure with internal antennas. For use in non-US countries only.
AP-6522-66030-EU	Dual 802.11n radio AP6522. Plastic enclosure with internal antennas. For use in EU countries only.
AP-6522-66040-US	Dual 802.11n radio AP6522. Metal enclosure with external antenna connectors. For use in US deployments only.
AP-6522-66040-WR	Dual 802.11n radio AP6522. Metal enclosure with external antenna connectors. For use in non-US countries only.
AP-6522-66040-EU	Dual 802.11n radio AP6522. Metal enclosure with external antenna connectors. For use in EU countries only.



NOTE In the above part numbers, a country code of “WR” represents a world wide model, whereas “US” defines the model as only legally deployable in the United States.

3. Review site survey and network analysis reports to determine the location and mounting position for the AP6522 Access Point.

4. Connect a CAT-5 or better Ethernet cable to a compatible 802.3af power source and run the cable to the installation site. Ensure there is sufficient slack on the cable to perform the installation steps.



NOTE When operating in a Gigabit Ethernet environment, CAT-5e or CAT-6 cable is recommended for Gigabit operation.

2.2 Precautions

Before installing an AP6522 model Access Point, verify the following:

- If a DC power supply is used, ensure it's the approved power supply for the AP6522 (PWRS-1400-148R).
- Motorola Solutions recommends you do not to install the AP6522 in wet or dusty areas.
- Verify the environment has a continuous temperature range between 0° C to 40° C.

2.3 Access Point Placement

For optimal performance, install the Access Point away from transformers, heavy-duty motors, fluorescent lights, microwave ovens, refrigerators and other industrial equipment. Signal loss can occur when metal, concrete, walls or floors block transmission. Install the Access Point in an open area or add Access Points as needed to improve coverage.

Antenna coverage is analogous to lighting. Users might find an area lit from far away to be not bright enough. An area lit sharply might minimize coverage and create *dark areas*. Uniform antenna placement in an area (like even placement of a light bulb) provides even, efficient coverage.

Place the Access Point using the following guidelines:

- Install the Access Point at an ideal height of 10 feet from the ground.
- Orient the Access Point antennas vertically for best reception (applies to external antenna models only).

To maximize the Access Point's radio coverage area, Motorola Solutions recommends conducting a site survey to define and document radio interference obstacles before installing the Access Point.

2.4 Integrated Antenna Model Wall Mount Instructions

Wall mounting requires hanging the AP6522 along its width or length using the two slots on the bottom of the unit. The AP6522 can be mounted on to any plaster, wood, or cement wall surface using customer supplied screw hardware (M3.5 x 0.6 x 20 mm- or equivalent).

2.4.1 Wall Mount Hardware

- Two wide-shoulder Phillips pan head self-tapping screws (customer supplied)
- Two wall anchors (customer supplied)
- Security cable (optional)



NOTE The following screws are recommended: (ANSI Standard) #6-18 X 0.875in. Type A or AB Self-Tapping Screw, or (ANSI Standard Metric) M3.5 X 0.6 X 20mm Type D Self-Tapping Screw.

2.4.2 Wall Mount Procedure

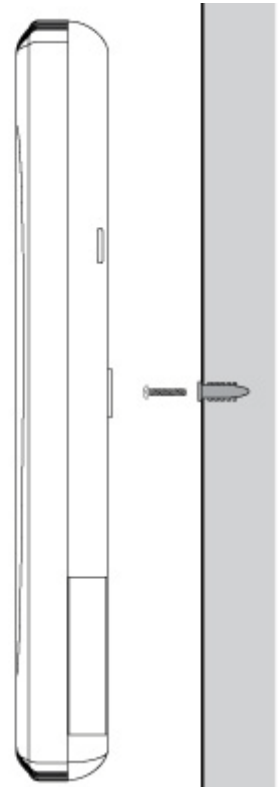
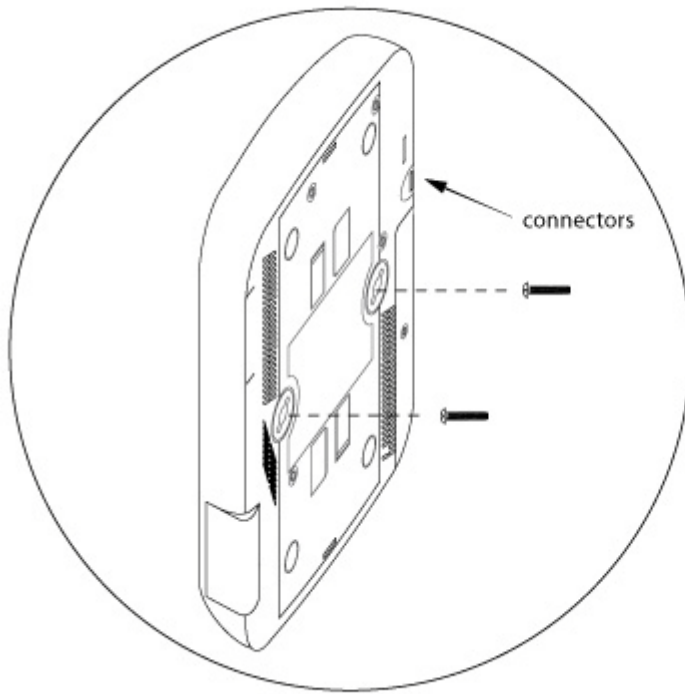

1. Orient the case on the wall by its width or length.



Correct Orientation



Incorrect Orientation



CAUTION To ensure proper operation of an AP6522 Access Point, ensure it is mounted in the correct orientation as shown above.

2. Mark two points (for drill holes) 4.08 inches (103.7 mm) apart on a horizontal line.
3. At each point, drill a hole in the wall, insert an anchor, screw into the anchor the wall mounting screw and stop when there is 1mm between the screw head and the wall.



NOTE When pre-drilling a hole the recommended hole size is 2.8mm (0.11 in.).

4. If required, install and attach a Kensington security cable (customer supplied) to the unit's lock port.
5. Attach an Ethernet cable from the Access Point to a controller with an 802.3af-compatible power source or use the PWRS-14000-148R power supply to supply power to the AP6522 (once fully cabled).
6. Place the middle of each of the case's mount slots over the screw heads.
7. Slide the case down along the mounting surface to hang the mount slots on the screw heads.
8. Verify the unit has power by observing that the LEDs are lit or flashing.



CAUTION If not using a 802.3af capable controller to power the AP6522, ensure only the AP6522's designated power supply (PWRS-14000-148R) is used to supply power to the Access Point. Using an incorrectly rated power supply could damage the unit and void the product warranty. Do not actually connect to the power source until the cabling portion of the installation is complete.

2.5 Integrated Antenna Model Suspended Ceiling T-Bar Mount

Ceiling mount requires holding the AP6522 Access Point up against a T-bar of a suspended ceiling grid and twisting the case onto the T-bar.

2.5.1 Suspended Ceiling T-Bar Mount Procedure

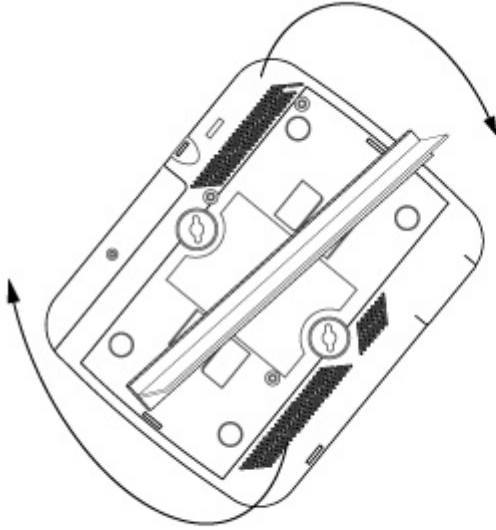

Plastic Under Ceiling Mount A

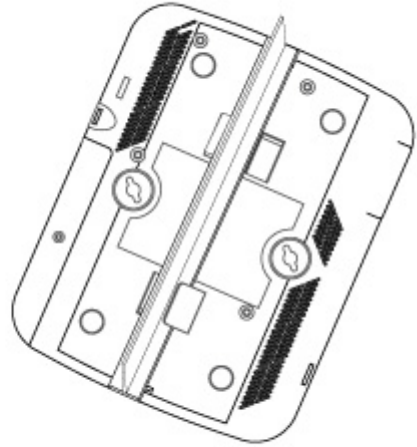

Plastic Under Ceiling Mount B

1. If required, install and attach a Kensington security cable (customer supplied) to the unit's lock port.
2. Attach an Ethernet cable from the Access Point to a controller with an 802.3af compatible power source or use the PWRS-14000-148R power supply to supply power to the AP6522 (once fully cabled).
3. Align the bottom of the T-bar with the back of the case.
4. Orient the case by its length, and the length of the T-bar.
5. Rotate the case 45 degrees clockwise, or about 10 o'clock.
6. Push the back of the case onto the bottom of the T-bar.
7. Rotate the case 45 degrees counter-clockwise. The clips click as they fasten to the T-bar.
8. Verify the unit has power by observing the LEDs.

CAUTION If not using a 802.3af capable controller to power the AP6522, ensure only the AP6522's designated power supply (PWRS-14000-148R) is used to supply power to the Access Point. Using an incorrectly rated power supply could damage the unit and void the product warranty. Do not actually connect to the power source until the cabling portion of the installation is complete.



2.6 External Antenna Model Wall Mount Instructions

A wall mount deployment requires hanging the AP6522 access point along its width or length using the pair of slots on the bottom of the unit. The AP6522 can be mounted on to any plaster, wood or cement wall surface using the provided wall anchors.

2.6.1 Wall Mount Hardware

- Two customer provided wide-shoulder Phillips pan head self-tapping screws (M3.5 x 0.6 x 20 mm)
- Two wall anchors (customer supplied)
- Security cable (optional)



NOTE The following screws are recommended: (ANSI Standard) #6-18 X 0.875in. Type A or AB Self-Tapping Screw, or (ANSI Standard Metric) M3.5 X 0.6 X 20mm Type D Self-Tapping Screw.

2.6.2 Wall Mount Procedure - New Installation

This section describes a new AP6522 installation with no previous Access Point existing on the intended wall surface.

1. Attach the two provided mounting ears (using four ear mounting screws) to the two narrow ends of the AP6522. Align the ears using the built in ear alignment pin on the Access Point housing. Torque the screws to 6 lb-in.

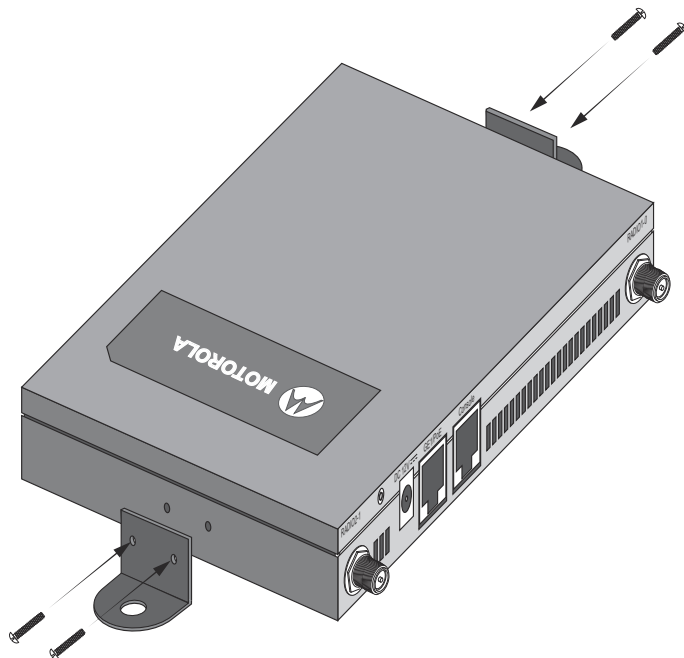

2. Place the Access Point against the wall, ensuring the Access Point's Motorola Solutions "bat wings" logo is in the correct orientation.
3. Mark the screw hole locations on a vertical axis using the ear's mounting holes.
4. At each point, drill a hole in the wall and insert the anchor.



NOTE When pre-drilling a hole the recommended hole size is 2.8mm (0.11 in.).

5. Place the Access Point on the anchor. Insert screws through the Access Point's mounting ears and into the anchor.
6. If required, install and attach a Kensington security cable (customer supplied) to the unit's lock port.
7. Attach an Ethernet cable from the Access Point to a controller with an 802.3af-compatible power source or use the PWRS-14000-148R power supply to supply power to the AP6522 (once fully cabled).
8. Attach appropriate antennas to the connectors.
9. Attach an Ethernet cable from the Access Point to a controller with an 802.3af compatible power source.
10. Verify the Access Point is receiving power by observing that the LEDs are lit or flashing.



CAUTION If not using a 802.3af capable controller to power the AP6522, ensure only the AP6522's designated power supply (PWRS-14000-148R) is used to supply power to the Access Point. Using an incorrectly rated power supply could damage the unit and void the product warranty. Do not actually connect to the power source until the cabling portion of the installation is complete.

2.6.3 Wall Mount Procedure - Existing Access Point Replacement

An existing external antenna model AP300 (WSAP-5100-100) or external antenna model AP650 (AP-0650-660X0) Access Point, installed on a wall (plenum installation), can be replaced by an AP6522. Simply remove the existing legacy model Access Point from its mounting screws, leave the mounting hardware in place and install the new external antenna model AP6522 directly on to the existing mounting hardware. The cabling procedure for such a replacement is as described in the previous section.

2.7 External Antenna Model Suspended Ceiling T-Bar Mount

Ceiling mount requires holding the AP6522 Access Point up against a T-bar of a suspended ceiling grid and twisting the case onto the T-bar. If deploying an external antenna model AP6522 on a ceiling T-Bar, Access Point mounting kit (Part No. KT-135628-01) or ceiling mount hardware (SCT-2) is required.

2.7.1 Suspended Ceiling T-Bar Mount Procedure - Using Mounting Kit

The following installation uses the Access Point mounting kit (Part No. KT-135628-01) to deploy the Access Point on a ceiling T-Bar.

1. If required, install and attach a Kensington security cable (customer provided) to the unit's lock port.
2. Using only the mounting bracket from the mounting kit, rotate and click the mounting bracket into the mounting slots on the AP6522.
3. Attach an Ethernet cable from the Access Point to a controller with an 802.3af compatible power source or use the PWRS-14000-148R power supply to supply power to the AP6522 (once fully cabled).
4. With the ceiling tile raised, slip the T-Bar bracket on to the exposed T-Bar flange.
5. Lower the ceiling tile and verify the stability of the T-Bar mounting bracket connection. There will be no stability in this assembly until the ceiling tile is lowered on to the T-Bar to secure the mounting hardware.
6. Verify the unit has power by observing the LEDs.



CAUTION If not using an 802.3af capable controller to power the AP6522, ensure only the AP6522's designated power supply (PWRS-14000-148R) is used to supply power to the Access Point. Using an incorrectly rated power supply could damage the unit and void the product warranty. Do not actually connect to the power source until the cabling portion of the installation is complete.

2.7.2 Suspended Ceiling T-Bar Mount Procedure - Using Ceiling Mount Hardware

The following installation uses the Access Point ceiling mounting kit (Part No. SCT-2) to deploy the Access Point on a ceiling T-Bar.

1. If required, install and attach a Kensington security cable (customer provided) to the unit's lock port.
2. Remove nut from the SCT-2 kit and place assembly and screw through Access Point mounting ear.
3. Place the clips from the SCT-2 ceiling mount kit over ceiling T-Bar.
4. Tighten clips using provided nuts.

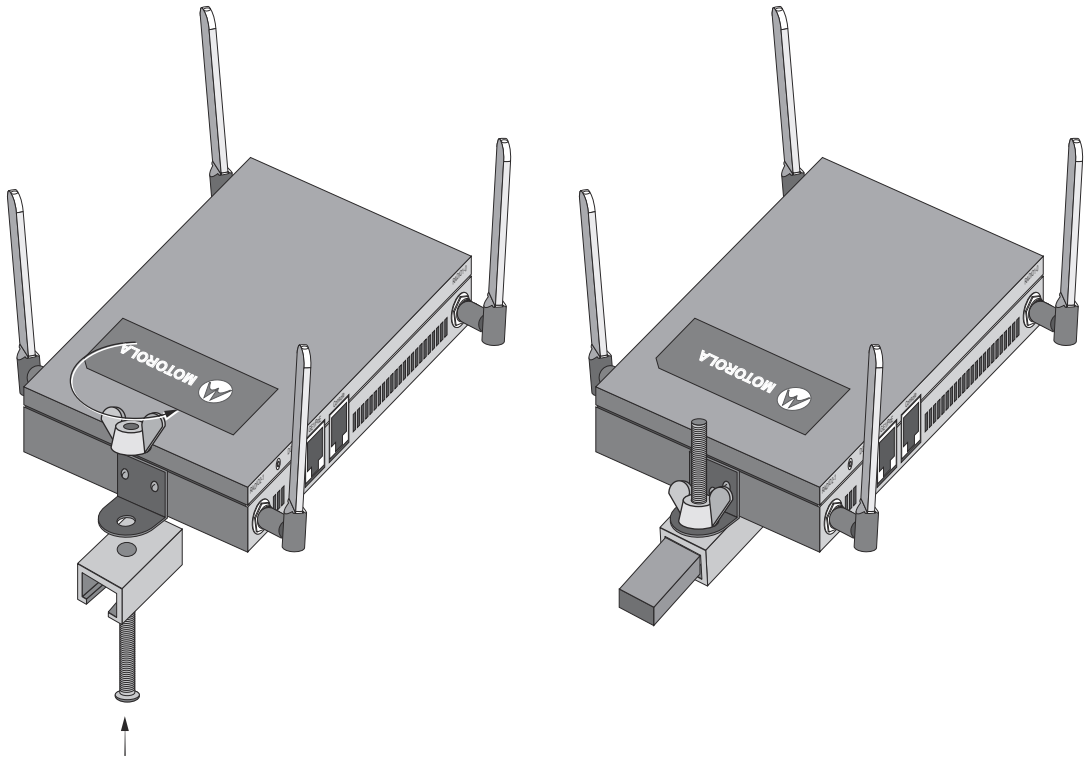

5. Attach an Ethernet cable from the Access Point to a controller with an 802.3af compatible power source or use the PWR-14000-148R power supply to supply power to the AP6522 (once fully cabled).
6. Attach appropriate antennas to the connectors.
7. Attach an Ethernet cable from the Access Point to the controller with an 802.3af compatible power source.
8. Verify the unit has power by observing the LEDs.



CAUTION If not using an 802.3af capable controller to power the AP6522, ensure only the AP6522's designated power supply (PWR-14000-148R) is used to supply power to the Access Point. Using an incorrectly rated power supply could damage the unit and void the product warranty. Do not actually connect to the power source until the cabling portion of the installation is complete.

2.8 External Antenna Suspended Ceiling Tile (Plenum) Mount

Ceiling mount requires placing the AP6522 access point above suspended ceiling tile.



NOTE Notes or warnings about suspended ceiling mounts apply to all installations where the unit is placed on suspended ceiling tile.



CAUTION Motorola Solutions does not recommend mounting the AP6522 access point directly to any suspended ceiling tile with a thickness less than 12.7mm (0.5in.) or a suspended ceiling tile with an unsupported span greater than 660mm (26in.). Motorola Solutions strongly recommends fitting the AP6522 access point with the supplied mounting ears and hanging the Access Point on a pipe or beam.

2.8.1 Suspended Ceiling Mount Hardware

- Security cable (optional)
- Mounting ears
- Customer supplied pipe or channel clamps

2.8.2 Ceiling Mount Procedure

1. If possible, remove the ceiling tile from its frame and place it, finish side down, on a work surface.
2. If required, install and attach a Kensington security cable (customer provided) to the unit's lock port.
3. Place the Access Point on the ceiling tile or attach to a plenum beam or pipe using industry available clamps.
4. Attach appropriate antennas to the connectors.
5. Bring the tile into the ceiling space
6. Attach an Ethernet cable from the Access Point to a controller with an 802.3af compatible power source or use the PWRS-14000-148R power supply to supply power to the AP6522 (once fully cabled).
7. Verify the Access Point is receiving power by observing the LEDs.
8. Place the ceiling tile back in its frame.



CAUTION If not using an 802.3af capable controller to power the AP6522, ensure only the AP6522's designated power supply (PWRS-14000-148R) is used to supply power to the Access Point. Using an incorrectly rated power supply could damage the unit and void the product warranty. Do not actually connect to the power source until the cabling portion of the installation is complete.

2.9 AP6522 External Antenna Model Antenna Options

Motorola Solutions supports two antenna suites for AP6522 External Antenna models. One antenna suite supporting the 2.4 GHz band and another antenna suite supporting the 5 GHz band. Select an antenna model best suited to the intended operational environment of your Access Point.



The 2.4 GHz antenna suite includes the following models:

Part Number	Antenna Type
ML-2452-APA2-01	Dipole Antenna
ML-2499-SD3-01R	Patch Antenna
ML-2499-HPA3-01R	Omni Antenna
ML-2452-PNA5-01R	Panel Antenna
ML-2452-PTA3M3-036	Omni Antenna
ML-2452-APAG2A1-01 (Black) ML-2452-APAG2A1-02 (White)	Dipole Antenna

The 5 GHz antenna suite includes the following models:

Part Number	Antenna Type
ML-2452-APA2-01	Dipole Antenna
ML-5299-PTA1-01R	Patch Antenna
ML-5299-HPA1-01R	Omni Antenna
ML-2452-PNA5-01R	Panel Antenna
ML-2452-PTA3M3-036	Omni Antenna
ML-2452-APAG2A1-01 (Black) ML-2452-APAG2A1-02 (White)	Dipole Antenna

For up-to-date information on supported antennas and antenna specifications, please refer to the *Motorola Solutions Enterprise Wireless LAN Antenna Specification Guide* available on the Motorola Solutions Web site. For more information, refer to <http://supportcentral.motorolasolutions.com/support/product/manuals.do>.

2.10 LED Indicators

Both Integrated Antenna and External Antenna models have LED activity indicators on the front of the case. With the External Antenna models mounted above a ceiling, LEDs are at the center of an oval badge on the ceiling.



The LEDs provide a status display indicating error conditions, transmission, and network activity for the 5 GHz 802.11an (amber) radio or the 2.4 GHz 802.11bgn (green) radio.

Task	5 GHz Activity LED (Amber)	2.4 GHz Activity LED (Green)
Unadopted	Off	Blink interval at 5 times a second
Normal Operation	<ul style="list-style-type: none">• If this radio band is enabled: Blink at 5 second interval• If this radio band is disabled: Off• If there is activity on this band: Blink interval at 1 time per second	<ul style="list-style-type: none">• If this radio band is enabled: Blink at 5 second interval• If this radio band is disabled: Off• If there is activity on this band: Blink interval at 1 time per second
Firmware Update	On	Off
Sensor Mode	Blink interval at 5 times a second	Blink interval at 5 times a second

3 Basic Access Point Configuration

Once the Access Point is installed and powered on, complete the following steps to get the device up and running and access management functions:

1. Attach an Ethernet cable from the Access Point to a controller with an 802.3af compatible power source or use the PWRS-14000-148R power supply to supply power to the AP6522 (once fully cabled).

If your host system is a DHCP server, an IP address is automatically assigned to the Access Point and can be used for device connection. However, if a DHCP server is not available, you'll need to derive the IP address from the Access Point MAC address. Using this method, the last two bytes of the Access Point MAC address become the last two octets of the IP address. For example:

MAC address - 00:C0:23:00:F0:0A

Zero-Config IP address - 169.254.240.10

To derive the Access Point's IP address using its MAC address:

- a. Open the Windows calculator by selecting *Start > All Programs > Accessories > Calculator*. This menu path may vary slightly depending on your version of Windows.
 - b. With the Calculator displayed, select *View > Scientific*. Select the **Hex** radio button.
 - c. Enter a hex byte of the Access Point's MAC address. For example, F0.
 - d. Select the **Dec** radio button. The calculator converts F0 into 240. Repeat this process for the last Access Point MAC address octet.
2. Point the Web browser to the Access Point's IP address. The following login screen displays:



Username

Password

Language

© 2004-2013 Motorola Solutions, Inc. All rights reserved.

3. Enter the default username *admin* in the **Username** field.
4. Enter the default password *motorola* in the **Password** field.
5. Click the **Login** button to load the management interface.



NOTE When logging in for the first time, you're prompted to change the password to enhance device security in subsequent logins.



NOTE If you get disconnected when running the wizard, you can connect again with the Access Point's actual IP address (once obtained) and resume the wizard.

6. If this is the first time the management interface has been accessed, the Initial Setup Wizard automatically displays.



Function Highlight

- Access Point Types: Virtual Controller AP, Standalone AP, or Dependent AP
- Networking Mode: Bridge or Router Operation
- LAN Configuration
- Radio Configuration
- WAN Configuration
- Wireless LAN Setup
- Location, Country Code, Time Zone, Date and Time
- Summary and Save/Commit

Choose One Type to Setup the Access Point

- Typical Setup (Recommended)
 - The wizard uses as many default parameters as possible to simply the configuration process.
- Advanced Setup
 - With this selection, you may configure the access point's LAN, WAN, Radio Mapping, Radius Server, WLAN, etc.



NOTE The Initial Setup Wizard displays the same pages and content for each Access Point model supported. The only difference being the number of radios configurable by model, as an AP7131 model can support up to three radios, AP6522, AP6532, AP6562, AP8132 and AP7161 models support two radios and AP6511 and AP6521 models support a single radio.

The Introduction screen displays the various actions that can be performed using the wizard under the **Function Highlight** field.

Use the **Choose One type to Setup the Access Point** field options to select the type of wizard to run. The **Typical Setup** is the recommended wizard. This wizard uses the default parameters for most of the configuration parameters and sets up a working network with the least amount of manual configuration.

The **Advanced Setup** wizard is for administrators who prefer more control over the different configuration parameters. A few more configuration screens are available for customization when the Advanced Setup wizard is used.

The first page of the *Initial Setup Wizard* displays the **Navigation Panel** and **Function Highlights** for the configuration activities comprising the Access Point's initial setup. This page also displays options to select the typical or advanced mode for the wizard.

The Navigation Panel for the Typical Setup Wizard displays the basic configuration options.



A green checkmark to the left of an item in the **Navigation Panel** defines the task as having its minimum required configuration set correctly. A red X defines a task as still requiring at least one parameter be defined correctly.

7. Select **Save/Commit** within each page to save the updates made to that page's configuration. Select **Next** to proceed to the next page listed in the Navigation Panel without saving your updates.



NOTE While you can navigate to any page in the navigation panel, you cannot complete the Initial AP Setup Wizard until each task in the Navigation Panel has a green checkmark.

For the purposes of this guide, use the **Typical Setup (Recommended)** option to simplify the process of getting the Access Point up and running quickly with a minimum number of changes to the Access Point's default configuration.

For information on using the Access Point's Advanced Setup option, refer to the *WiNG Access Point System Reference Guide* to familiarize yourself with the feature set supported by the WiNG operating system. The guide is available at <http://supportcentral.motorolasolutions.com/support/product/manuals.do>.

To configure the Access Point using the Typical Setup Wizard:

8. Select **Typical Setup** from the **Choose One type to Setup the Access Point** field on the Initial Setup Wizard.
9. The Typical Setup Wizard displays the **Access Point Settings** screen to define the Access Point's Standalone versus Virtual Controller AP functionality. This screen also enables selection of the country of operation for the Access Point.

Access Point Type Selection

- Virtual Controller AP - When more than one access point is deployed, a single access point can function as a Virtual Controller AP and manage Dependent mode access points. The Virtual Controller AP can adopt and configure other like APs in a 24-cell deployment.
- Standalone AP - Select this option to deploy this access point as an autonomous "fat" access point. A standalone AP isn't managed by a Virtual Controller AP, or adopted by a controller.

Country

10. Select an **Access Point Type** from the following options:
 - *Virtual Controller AP* - When more than one Access Point is deployed, a single Access Point can function as a Virtual Controller AP. Up to 24 Access Points can be connected to, and managed by, a single Virtual Controller AP of the same Access Point model. These connected Access Points must be the same model as the Virtual Controller AP.
 - *Standalone AP* - Select this option to deploy this Access Point as an autonomous fat Access Point.

A Standalone AP isn't managed by a Virtual Controller AP, or adopted by a controller.



NOTE If wanting to adopt the Access Point to a controller or service platform, use the controller or service platform's resident UI to connect to the Access Point, provision its configuration and administrate the Access Point's configuration.



NOTE If designating the Access Point as a Standalone AP, Motorola Solutions recommends the Access Point's UI be used exclusively to define its device configuration, and not the CLI. The CLI provides the ability to define more than one profile and the UI does not. Consequently, the two interfaces cannot be used collectively to manage profiles without an administrator encountering problems.

11. Select the **Country Code** of the country where the Access Point is deployed. Selecting a proper country is a critical task while configuring the Access Point, as it defines the correct channels of operation and ensures compliance to the regulations of the selected country. This field is only available for the Typical Setup Wizard.
12. Select **Next** to set the Access Point's network mode.

13. The Typical Setup Wizard displays the **Network Topology** screen to define how the Access Point handles network traffic.

Network Topology

- Router Mode - the access point routes traffic between the wireless network and the Internet or corporate network (WAN).

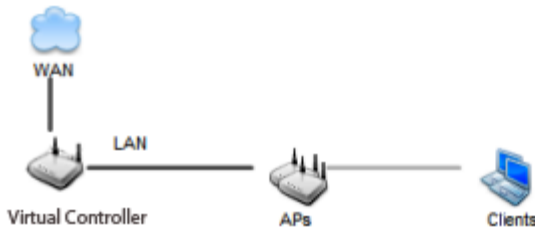

- Bridge Mode - In Bridge Mode, the access point depends on an external router for routing LAN and WAN traffic. Routing is generally used on one device, whereas bridging is typically used in a larger density network. Thus, select Bridge Mode when deploying this access point with numerous peer APs supporting clients on both the 2.4 and 5GHz radio bands.

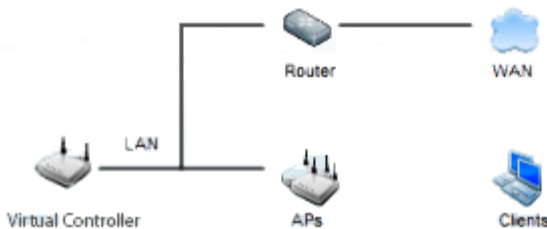

14. Select an Access Point Mode from the available options.

- *Router Mode* - In Router Mode, the Access Point routes traffic between the local network (LAN) and the Internet or external network (WAN). Router mode is recommended in a deployment supported by just a single Access Point.
- *Bridge Mode* - In Bridge Mode, the Access Point depends on an external router for routing LAN and WAN traffic. Routing is generally used on one device, whereas bridging is typically used in a larger density network. Select Bridge Mode when deploying this Access Point with numerous peer Access Points supporting clients on both the 2.4GHz and 5GHz radio bands.



NOTE When Bridge Mode is selected, WAN configuration cannot be performed and the Typical Setup Wizard does not display the WAN configuration screen.

15. Select **Next**. The Typical Setup Wizard displays the **LAN Configuration** screen to set the Access Point's LAN interface configuration.

 **LAN Configuration**

Please configure interface settings for LAN (VLAN 1) which will be used by wireless clients

Use DHCP [What is this?](#)

Static IP Address/Subnet [What is this?](#) *

DHCP Server

Use on-board DHCP server to assign IP addresses to wireless clients

Range --

Default Gateway

Domain Name Server (DNS)

DNS Forwarding

Primary DNS Secondary DNS

16. Set the following DHCP and Static IP Address/Subnet information for the LAN interface:
- *Use DHCP* - Select the checkbox to enable an automatic network address configuration using the Access Point's DHCP server.
 - *Static IP Address/Subnet* - Enter an IP Address and a subnet for the Access Point's LAN interface. If *Use DHCP* is selected, this field is not available. When selecting this option, define the following *DHCP Server* and *Domain Name Server (DNS)* resources, as those fields will become enabled on the bottom portion of the screen.
 - *Use on-board DHCP server to assign IP addresses to wireless clients* - Select the checkbox to enable the Access Point's DHCP server to provide IP and DNS information to clients on the LAN interface.
 - *Range* - Enter a starting and ending IP Address range for client assignments on the LAN interface. Avoid assigning IP addresses from x.x.x.1 - x.x.x.10 and x.x.x.255, as they are often reserved for standard network services. This is a required parameter.
 - *Default Gateway* - Define a default gateway address for use with the default gateway. This is a required parameter.

- *DNS Forwarding* - Select this option to allow a DNS server to translate domain names into IP addresses. If this option is not selected, a primary and secondary DNS resource must be specified. DNS forwarding is useful when a request for a domain name is made but the DNS server, responsible for converting the name into its corresponding IP address, cannot locate the matching IP address.
 - *Primary DNS* - Enter an IP Address for the main Domain Name Server providing DNS services for the Access Point's LAN interface.
 - *Secondary DNS* - Enter an IP Address for the backup Domain Name Server providing DNS services for the Access Point's LAN interface.
17. Select **Next**. The Typical Setup Wizard displays the **Wireless LAN Setup** screen to set the Access Point's Wireless LAN interface configuration.

WLAN 1 WLAN 2

 **WLAN 1 Configuration**

SSID [What is this?](#) *

WLAN Type No Authentication and No Encryption [What is this?](#)

Captive Portal Authentication and No Encryption [What is this?](#)

PSK authentication, WPA2 encryption [What is this?](#)

18. Set the following WLAN1 Configuration parameters:
- *SSID* - Configure the SSID for the WLAN.
 - *WLAN Type* - Configure the encryption and authentication to use with this WLAN.
 - *No Authentication and No Encryption* - Configures a network without any authentication. This option also configures the network without encryption. This means that any data transmitted through the network is in plain text. Any device between end points can see the information transmitted. This is the least secure of all network configurations.
 - *Captive Portal Authentication and No Encryption* - Configures a network that uses a RADIUS server to authenticate users before allowing them on to the network. Once on the network, no encryption is used for the data being transmitted through the network. Select this option to use a Web page (either internally or externally hosted) to authenticate users before access is granted to the network.
 - *PSK authentication, WPA2 encryption* - Configures a network that uses PSK authentication and WPA2 encryption. Select this option to implement a pre-shared key that must be correctly shared between the Access Point and requesting clients using this WLAN.

21. Select **Add User** to display the dialog to enter user information to add to the RADIUS server user database.

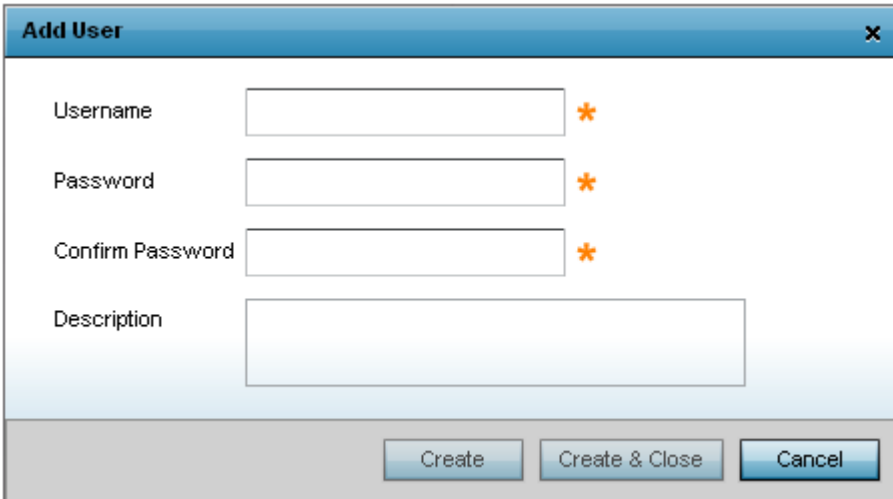

The screenshot shows a dialog box titled "Add User" with a close button (X) in the top right corner. The dialog contains four input fields: "Username", "Password", "Confirm Password", and "Description". Each of the first three fields has a red asterisk (*) to its right, indicating they are required. At the bottom of the dialog, there are three buttons: "Create", "Create & Close", and "Cancel".

22. Enter the following user information:
 - *Username* - Provide a user name used to authenticate the user.
 - *Password* - Provide a password used to authenticate the user.
 - *Confirm Password* - Confirm the password by entering the same password as entered in the Password field.
 - *Description* - Provide a description to identify the user created in the RADIUS server database.
23. To create the entry in the RADIUS server database and add another user, select **Create**. To create the entry in the RADIUS server database and close the Add User dialog, select **Create & Close**.
24. Select **Modify User** on the RADIUS Server Configuration screen to modify information for an existing user from the RADIUS database. Highlight the user entry then select **Modify User**.



NOTE The *Username* cannot be modified with this dialog.

25. Select **Delete User** on the RADIUS Server Configuration screen to remove information for an existing user from the RADIUS database. Highlight the user entry and select **Delete User**.
26. Select **Confirm** on the dialog displayed. The entry for the user is removed from the RADIUS database.
27. To dismiss the dialog without adding, modifying or removing entries in the RADIUS server database, select **Cancel**.

28. Select **Next**. The Typical Setup Wizard displays the **Summary and Commit** screen to summarize the screens (pages) and settings updated using the Typical Setup Wizard.

 **Access Point Type Page** _____

Access Point Type Standalone AP

 **Networking Mode Page** _____

Networking Mode Router Mode

 **LAN Configuration Page** _____

LAN Configuration Type Static IP Address/Subnet

VLAN ID for the LAN Interface 1

Static IP Address/Subnet 192.168.13.23/24

 **WAN Configuration Page** _____

WAN Configuration Type Use DHCP

Port to External GE1 Port

 **WLAN Configuration** _____

No user intervention or additional settings are required. Its an additional means of validating the Access Point's updated configuration before it's deployed. However, if a screen displays settings not intended as part of the initial configuration, then any screen can be selected again from within the Navigation Panel and its settings modified accordingly.

29. If the configuration displays as intended, select **Save/Commit** to implement these settings to the Access Point's configuration. If additional changes are warranted based on the summary, either select the target page from the **Navigational Panel**, or use the **Back** and **Next** buttons to scroll to the target screen.

4 Specifications

4.1 AP6522 Integrated Antenna Model Electrical Characteristics

An AP6522 Integrated model Access Point has the following electrical characteristics:

<i>Operating Current & Voltage</i>	12VDC, 1A (accessory power connector) 48V,0.25A (PoE connector)
--	--

4.2 AP6522 Integrated Antenna Model Physical Characteristics

An AP6522 Integrated Antenna model Access Point has the following physical characteristics:

<i>Dimensions</i>	9.38 inches x 7.5 inches x 1.38 inches 23.82 cm x 19.50 cm x 3.50 cm
<i>Housing</i>	Plastic
<i>Weight</i>	0.90 lbs / 0.40 kg
<i>Operating Temperature</i>	32°F to 104°F/0°C to 40°C
<i>Storage Temperature</i>	-40°F to 185°F/-40°C to 85°C
<i>Operating Humidity</i>	5 to 95% Relative Humidity non-condensing
<i>Storage Humidity</i>	85% Relative Humidity non-condensing
<i>Operating Altitude (max)</i>	8,000 ft @ 28C
<i>Storage Altitude (max)</i>	30,000 ft @ 12C
<i>Electrostatic Discharge</i>	+/-15kV Air and +/-8kV Contact @ 50% Relative Humidity

4.3 AP6522 External Antenna Model Electrical Characteristics

An AP6522 External Antenna model Access Point has the following electrical characteristics:

<i>Operating Current & Voltage</i>	12VDC, 1A (accessory power connector) 48V,0.25A (PoE connector)
--	--

4.4 AP6522 External Antenna Model Physical Characteristics

An AP6522 External Antenna model Access Point has the following physical characteristics:

<i>Dimensions</i>	7.88 inches x 5.00 inches x 1.00 inches 20.01 cm x 12.70 cm x 2.54 cm
<i>Housing</i>	Metal
<i>Weight</i>	1.45 lbs / 0.65 kg
<i>Operating Temperature</i>	32°F to 104°F/0°C to 40°C
<i>Storage Temperature</i>	-40°F to 185°F/-40°C to 85°C
<i>Operating Humidity</i>	5 to 95% Relative Humidity non-condensing
<i>Storage Humidity</i>	85% Relative Humidity non-condensing
<i>Operating Altitude (max)</i>	8,000 ft @ 28C
<i>Storage Altitude (max)</i>	30,000 ft @ 12C
<i>Electrostatic Discharge</i>	+/-15kV Air and +/-8kV Contact @ 50% Relative Humidity

4.5 Radio Characteristics

The AP6522 model Access Points have the following radio characteristics:

<i>Operating Channels</i>	All channels from 4920 MHz to 5825 MHz except channel 52 -64 Channels 1-13 (2412-2472 MHz) Channel 14 (2484 MHz) Japan only Actual operating frequencies depend on regulatory approval for the country of use.
<i>Data Rates Supported</i>	802.11b: 1,2,5.5,11Mbps 802.11g: 1,2,5.5,11,6,9,12,18,24,36,48, and 54Mbps 802.11a: 6,9,12,18,24,36,48, and 54Mbps 802.11n: MCS 0-15 up to 300Mbps
<i>Wireless Medium</i>	<i>Direct Sequence Spread Spectrum (DSSS), Orthogonal Frequency Division Multiplexing (OFDM) Spatial multiplexing (MIMO)</i>
<i>Network Standards</i>	802.11a, 802.11b, 802.11g, 802.3, 802.11n (Draft 2.0)
Maximum Available Transmit Power	Maximum available conducted transmit power per chain: 2.4 GHz: 21dBm Maximum available conducted transmit power all chains: 2.4 GHz: 24dBm Maximum available conducted transmit power per chain: 5 GHz: 19dBm Maximum available conducted transmit power all chains: 5 GHz: 22dBm
Transmit Power Adjustment	1dB increments

5 Regulatory Information

This device is approved under the Symbol Technologies, Inc. brand: Symbol Technologies, Inc. is a wholly owned subsidiary of Motorola Solutions, Inc. (collectively "Motorola").

This guide applies to Model Number AP6522. The AP6522 Access Point is approved under MODEL: AP-0622.

All Motorola/Symbol devices are designed to be compliant with rules and regulations in locations they are sold and will be labeled as required.

Local language translations are available at the following website:

<http://www.motorolasolutions.com/support>

Any changes or modifications to Motorola/Symbol Technologies equipment, not expressly approved by Motorola/Symbol Technologies, could void the user's authority to operate the equipment.

Motorola/Symbol devices are professionally installed, the Radio Frequency Output Power will not exceed the maximum allowable limit for the country of operation.

Antennas: Use only the supplied or an approved replacement antenna. Unauthorized antennas, modifications, or attachments could cause damage and may violate regulations.

This device is only to be used with a Motorola/Symbol Technologies Wireless Switch.

5.1 Country Approvals

Regulatory markings, subject to certification, are applied to the device signifying the radio(s) is/are approved for use in the following countries: United States, Canada, Japan, China, S. Korea, Australia, and rope.

Please refer to the Declaration of Conformity (DoC) for details of other country markings. This is available at:

<http://www.motorolasolutions.com/doc>

Note: For 2.4GHz or 5GHz Products: rope includes, Austria, Belgium, Bulgaria, Czech Republic, Cyprus, Denmark, Estonia, Finland, France, Germany, Greece, Hungary, Iceland, Ireland, Italy, Latvia, Liechtenstein, Lithuania, Luxembourg, Malta, Netherlands, Norway, Poland, Portugal, Romania, Slovak Republic, Slovenia, Spain, Sweden, Switzerland and the United Kingdom.



Operation of the device without regulatory approval is illegal.

5.2 Health and Safety Recommendations

5.2.1 Country Selection

Select only the country in which you are using the device. Any other selection will make the operation of this device illegal.

5.2.2 Frequency of Operation – FCC and IC

You are reminded of the need to observe restrictions on the use of radio devices in fuel depots, chemical plants etc. and areas where the air contains chemicals or particles (such as grain, dust, or metal powders).

5 GHz Only

The use in the UNII (Unlicensed National Information Infrastructure) band 1 (5150-5250 MHz) is restricted to Indoor Use Only; any other use will make the operation of this device illegal.

Industry Canada Statement:

Caution: The device for the band 5150-5250 MHz is only for indoor usage to reduce potential for harmful interference to co-Channel mobile satellite systems. High power radars are allocated as primary users (meaning they have priority) of 5250-5350 MHz and 5650-5850 MHz and these radars could cause interference and/or damage to LE-LAN devices.

Avertissement: Le dispositif fonctionnant dans la bande 5150-5250 MHz est réservé uniquement pour une utilisation à l'intérieur afin de réduire les risques de brouillage préjudiciable aux systèmes de satellites mobiles utilisant les mêmes canaux.

Les utilisateurs de radars de haute puissance sont désignés utilisateurs principaux (c.-à-d., qu'ils ont la priorité) pour les bandes 5250-5350 MHz et 5650-5850 MHz et que ces radars pourraient causer du brouillage et/ou des dommages aux dispositifs LAN-EL.

5.3 Health and Safety Recommendations

5.3.1 Warnings for Use of Wireless Devices



Please observe all warning notices with regard to the usage of wireless devices.

5.3.2 Potentially Hazardous Atmospheres - Fixed Installations

You are reminded of the need to observe restrictions on the use of radio devices in fuel depots, chemical plants etc. and areas where the air contains chemicals or particles (such as grain, dust, or metal powders).

5.3.3 Safety in Hospitals



Wireless devices transmit radio frequency energy and may affect medical electrical equipment. When installed adjacent to other equipment, it is advised to verify that the adjacent equipment is not adversely affected.

Pacemakers

Pacemaker manufacturers recommended that a minimum of 15cm (6 inches) be maintained between a handheld wireless device and a pacemaker to avoid potential interference with the pacemaker. These recommendations are consistent with independent research and recommendations by Wireless Technology Research.

Persons with Pacemakers:

- Should ALWAYS keep the device more than 15cm (6 inches) from their pacemaker when turned ON.
- Should not carry the device in a breast pocket.
- Should use the ear furthest from the pacemaker to minimize the potential for interference.
- If you have any reason to suspect that interference is taking place, turn OFF your device.

Other Medical Devices

Please consult your physician or the manufacturer of the medical device, to determine if the operation of your wireless product may interfere with the medical device.

5.4 RF Exposure Guidelines

5.4.1 Reducing RF Exposure - Use Properly

Only operate the device in accordance with the instructions supplied.

5.4.2 International

The device complies with internationally recognized standards covering human exposure to electromagnetic fields from radio devices. For information on "International" human exposure to electromagnetic fields refer to the Motorola/Symbol *Declaration of Conformity* (DoC) at: <http://www.motorolasolutions.com/doc>

5.4.3

Remote and Standalone Antenna Configurations

To comply with RF exposure requirements, antennas that are mounted externally at remote locations or operating near users at stand-alone desktop or similar configurations must operate with a minimum separation distance of 20 cm from all persons.

5.4.4 US and Canada

Co-located statement

To comply with FCC RF exposure compliance requirement, the antennas used for this transmitter must not be co-located or operating in conjunction with any other transmitter/antenna except those already approved in this filling.

Remote and Standalone Antenna Configurations

To comply with FCC RF exposure requirements, antennas that are mounted externally at remote locations or operating near users at stand-alone desktop of similar configurations must operate with a minimum separation distance of 20 cm from all persons.

5.5 Power Supply

Use ONLY a LISTED Motorola, Type no. PWRS-14000-148R (12VDC @ 4.16A), direct plug-in power supply, marked Class 2 (IEC60950-1, SELV).

This device can be powered from a 802.3af compliant power source which is certified by the appropriate agencies.

Use of alternative Power Supply will invalidate any approvals given to this unit and may be dangerous.

5.6 Wireless Devices - Countries

5.6.1 Country Selection

Select only the country in which you are using the device. Any other selection will make the operation of this device illegal.

**NOTE**

The US only models (AP-6522-66030-US and AP-6522-66040-US) have the country code permanently set to the US. The WR models (AP-6522-66030-WR and AP-6522-66040-WR) cannot be configured for use in the US.

5.6.2 Operation in the US and Canada

The use on UNII (Unlicensed National Information Infrastructure) Band 1 5150-5250 MHz is restricted to indoor use only, any other use will make the operation of this device illegal.

The available channels for 802.11 bg operation in the US are Channels 1 to 11. The range of channels is limited by firmware.

5.6.3 Radio Frequency Interference Requirements—FCC

This equipment has been tested and found to comply with the limits for a Class B digital device, pursuant to Part 15 of the FCC rules. These limits are designed to provide reasonable protection against harmful interference in a residential installation. This equipment generates, uses and can radiate radio frequency energy and, if not installed and used in accordance with the instructions,



may cause harmful interference to radio communications. However there is no guarantee that interference will not occur in a particular installation. If this equipment does cause harmful interference to radio or television reception, which can be determined by turning the equipment off and on, the user is encouraged to try to correct the interference by one or more of the following measures:

- Reorient or relocate the receiving antenna
- Increase the separation between the equipment and receiver
- Connect the equipment into an outlet on a circuit different from that to which the receiver is connected
- Consult the dealer or an experienced radio/TV technician for help.

Radio Transmitters (Part 15)

This device complies with Part 15 of the FCC Rules. Operation is subject to the following two conditions: (1) this device may not cause harmful interference, and (2) this device must accept any interference received, including interference that may cause undesired operation.

5.6.4 Radio Frequency Interference Requirements – Canada

This Class B digital apparatus complies with Canadian ICES-003.

Cet appareil numérique de la classe B est conforme à la norme NMB-003 du Canada.

Radio Transmitters

For RLAN Devices:

The use of 5 GHz RLAN's, for use in Canada, have the following restrictions:

- Restricted Band 5.60 – 5.65 GHz

This device complies with RSS 210 of Industry Canada. Operation is subject to the following two conditions: (1) this device may not cause harmful interference and (2) this device must accept any interference received, including interference that may cause undesired operation.

Ce dispositif est conforme à la norme CNR-210 d'Industrie Canada applicable aux appareils radio exempts de licence. Son fonctionnement est sujet aux dx conditions suivantes: (1) le dispositif ne doit pas produire de brouillage préjudiciable, et (2) ce dispositif doit accepter tout brouillage reçu, y compris un brouillage susceptible de provoquer un fonctionnement indésirable.

Label Marking: The Term "IC:" before the radio certification signifies that Industry Canada technical specifications were met.



5.7 CE Marking and ropean Economic Area (EEA)

The use of 2.4GHz RLAN's, for use through the EEA, have the following restrictions:

- Maximum radiated transmit power of 100 mW EIRP in the frequency range 2.400 -2.4835 GHz.
- France outside usage, the equipment is restricted to 2.400-2.45 GHz frequency range.
- Italy requires a user license for outside usage.

5.8 Statement of Compliance

Motorola hereby, declares that this device is in compliance with the essential requirements and other relevant provisions of Directive 1999/5/EC. A Declaration of Conformity may be obtained from <http://www.motorolasolutions.com/doc>.

5.9 Korea Warning Statement for Class B ITE

기종별	사용자안내문
B급 기기< (가정용 방송통신기기)	이 기기는 가정용 (B 급) 으로 전자파적합등록을 한 기기로서 주로 가정에서 사용하는 것을 목적으로 하며, 모든 지역에서 사용할 수 있습니다
Class B (Broadcasting Communication Device for Home Use)	This device obtained EMC registration mainly for home use (Class B) and may be used in all areas.

5.10 Other Countries

Australia

Use of 5GHz RLAN's in Australia is restricted in the following band 5.50 – 5.65GHz.

Brazil

Declarações Regulamentares para AP6522 - Brasil

Nota: A marca de certificação se aplica ao Transceptor, modelo AP6522. Este equipamento opera em caráter secundário, isto é, não tem direito a proteção contra interferência prejudicial, mesmo de estações do mesmo tipo, e não pode causar interferência a sistemas operando em caráter primário. Para maiores informações sobre ANATEL consulte o site: www.anatel.gov.br

Chile

Este equipo cumple con la Resolución No 403 de 2008, de la Subsecretaria de telecomunicaciones, relativa a radiaciones electromagnéticas.

Mexico

Restrict Frequency Range to: 2.450 – 2.4835 GHz.

Taiwan**臺灣**

低功率電波輻射性電機管理辦法

第十二條

經型式認證合格之低功率射頻電機，非經許可，公司、商號或使用者均不得擅自變更頻率、加大功率或變更原設計之特性及功能。

第十四條

低功率射頻電機之使用不得影響飛航安全及干擾合法通信；經發現有干擾現象時，應立即停用，並改善至無干擾時方得繼續使用。

前項合法通信，指依電信規定作業之無線電通信。

低功率射頻電機須忍受合法通信或工業、科學及醫療用電波輻射性電機設備之干擾。

在 5.25-5.35 兆赫頻帶內操作之無線資訊傳輸設備，限於室內使用

Korea

당해 무선설비는 운용 중 전파혼신 가능성이 있음

당해 무선설비는 전파혼신 가능성이 있으므로 인명안전과 관련된 서비스는 할 수 없습니다.

5.11 Waste Electrical and Electronic Equipment (WEEE)



English: For EU Customers: All products at the end of their life must be returned to Motorola Solutions for recycling. For information on how to return product, please go to:

<http://www.motorolasolutions.com/recycling/weee>.

Français: Clients de l'Union Européenne: Tous les produits en fin de cycle de vie doivent être retournés à Motorola Solutions pour recyclage. Pour de plus amples informations sur le retour de produits, consultez :

<http://www.motorolasolutions.com/recycling/weee>.

Español: Para clientes en la Unión Europea: todos los productos deberán entregarse a Motorola Solutions al final de su ciclo de vida para que sean reciclados. Si desea más información sobre cómo devolver un producto, visite:

<http://www.motorolasolutions.com/recycling/weee>.

Български: За клиенти от ЕС: След края на полезния им живот всички продукти трябва да се връщат на Motorola Solutions за рециклиране. За информация относно връщането на продукти, моля отидете на адрес: <http://www.motorolasolutions.com/recycling/weee>.

Deutsch: Für Kunden innerhalb der EU: Alle Produkte müssen am Ende ihrer Lebensdauer zum Recycling an Motorola Solutions zurückgesandt werden. Informationen zur Rücksendung von Produkten finden Sie unter <http://www.motorolasolutions.com/recycling/weee>.

Italiano: per i clienti dell'UE: tutti i prodotti che sono giunti al termine del rispettivo ciclo di vita devono essere restituiti a Motorola Solutions al fine di consentirne il riciclaggio. Per informazioni sulle modalità di restituzione, visitare il seguente sito Web: <http://www.motorolasolutions.com/recycling/weee>.

Português: Para clientes da UE: todos os produtos no fim de vida devem ser devolvidos à Motorola Solutions para reciclagem. Para obter informações sobre como devolver o produto, visite:

<http://www.motorolasolutions.com/recycling/weee>.

Nederlands: Voor klanten in de EU: alle producten dienen aan het einde van hun levensduur naar Motorola Solutions te worden teruggezonden voor recycling. Raadpleeg <http://www.motorolasolutions.com/recycling/weee> voor meer informatie over het terugzenden van producten.

Polski: Klienci z obszaru Unii Europejskiej: Produkty wycofane z eksploatacji należą i zwrócić do firmy Motorola Solutions w celu ich utylizacji. Informacje na temat zwrotu produktów znajdują¹ się na stronie internetowej

<http://www.motorolasolutions.com/recycling/weee>.

Čeština: Pro zákazníky z EU: Všechny produkty je nutné po skončení jejich životnosti vrátit společnosti Motorola Solutions k recyklaci. Informace o způsobu vrácení produktu najdete na webových stránce:

<http://www.motorolasolutions.com/recycling/weee>.

Eesti: EL klientidele: kõik tooted tuleb nende eluea lõppedes tagastada taaskasutamise eesmärgil Motorola Solutions'ile. Lisainformatsiooni saamiseks toote tagastamise kohta külastage palun aadressi:

<http://www.motorolasolutions.com/recycling/weee>.

Magyar: Az EU-ban vásárlóknak: Minden tönkrement termékét a Motorola Solutions vállalathoz kell eljuttatni újrahasznosítás céljából. A termék visszajuttatásának módjával kapcsolatos tudnivalóért látogasson el a <http://www.motorolasolutions.com/recycling/weee> weboldalra.

Svenska: För kunder inom EU: Alla produkter som uppnått sin livslängd måste returneras till Motorola Solutions för återvinning. Information om hur du returnerar produkten finns på

<http://www.motorolasolutions.com/recycling/weee>.

Suomi: Asiakkaat Euroopan unionin alueella: Kaikki tuotteet on palautettava kierrätettäväksi Motorola Solutions-yhtiöön, kun tuotetta ei enää käytetä. Lisätietoja tuotteen palauttamisesta on osoitteessa

<http://www.motorolasolutions.com/recycling/weee>.

Dansk: Til kunder i EU: Alle produkter skal returneres til Motorola Solutions til recirkulering, når de er udtjent. Læs oplysningerne om returnering af produkter på: <http://www.motorolasolutions.com/recycling/weee>.

Ελληνικά: Για πελάτες στην Ε.Ε.: Όλα τα προϊόντα, στο τέλος της διάρκειας ζωής τους, πρέπει να επιστρέφονται στην Motorola Solutions για ανακύκλωση. Για περισσότερες πληροφορίες σχετικά με την επιστροφή ενός προϊόντος, επισκεφθείτε τη διεύθυνση <http://www.motorolasolutions.com/recycling/weee> στο Διαδίκτυο.

Malti: Għal klijenti fl-UE: il-prodotti kollha li jkunu waslu fl-aħħar tal-ħajja ta' l-użu tagħhom, iridu jiġu rritornati għand Motorola Solutions għar-riċiklaġġ. Għal aktar tagħrif dwar kif għandek tirritorna l-prodott, jekk jogħġbok żur: <http://www.motorolasolutions.com/recycling/weee>.

Românesc: Pentru clienții din UE: Toate produsele, la sfârșitul duratei lor de funcționare, trebuie returnate la Motorola Solutions pentru reciclare. Pentru informații despre returnarea produsului, accesați: <http://www.motorolasolutions.com/recycling/weee>.

Slovenski: Za kupce v EU: vsi izdelki se morajo po poteku življenjske dobe vrniti podjetju Motorola Solutions za reciklažo. Za informacije o vračilu izdelka obiščite: <http://www.motorolasolutions.com/recycling/weee>.

Slovenčina: Pre zákazníkov z krajín EU: Všetky výrobky musia byť po uplynutí doby ich životnosti vrátené spoločnosti Motorola Solutions na recykláciu. Bližšie informácie o vrátení výrobkov nájdete na: <http://www.motorolasolutions.com/recycling/weee>.

Lietuvių: ES vartotojams: visi gaminiai, pasibaigus jų eksploatacijos laikui, turi būti gražinti utilizuoti į kompaniją „Motorola Solutions“. Daugiau informacijos, kaip gražinti gaminį, rasite: <http://www.motorolasolutions.com/recycling/weee>.

Latviešu: ES klientiem: visi produkti pēc to kalpošanas mūža beigām ir jānogādā atpakaļ Motorola Solutions otrreizējai pārstrādei. Lai iegūtu informāciju par produktu nogādāšanu Motorola, lūdzu, skatiet: <http://www.motorolasolutions.com/recycling/weee>.

Türkçe: AB Müşterileri için: Kullanım süresi dolan tüm ürünler geri dönüşürme için Motorola Solutions'ya iade edilmelidir. Ürünlerin nasıl iade edileceği hakkında bilgi için lütfen şu adresi ziyaret edin: <http://www.motorolasolutions.com/recycling/weee>.

5.12 TURKISH WEEE Statement of Compliance

EEE Yönetmeliğine Uygundur

6 Motorola Solutions Support Center

If you have a problem with your equipment, contact support for your region.

Contact information is available at: <http://www.motorolasolutions.com/support>.

When contacting Motorola Solutions support, please provide the following information:

- Serial number of the unit
- Model number or product name
- Software type and version number

Motorola Solutions responds to calls by e-mail, telephone, or fax within the time limits set forth in support agreements. If you purchased your product from a Motorola Solutions business partner, contact that business partner for support.

Customer Support Web Sites

The Motorola Solutions Support Central Web site, located at <http://supportcentral.motorolasolutions.com> provides information and online assistance including developer tools, software downloads, product manuals and online repair requests.

Manuals

<http://supportcentral.motorolasolutions.com/support/product/manuals.do>

General Information

Obtain additional information by contacting Motorola Solutions at:

Telephone (North America): 1-800-722-6234

Telephone (International): +1-631-738-5200

Website: <http://www.motorolasolutions.com>

7 AP6522 Access Point China ROHS Compliance

部件名称 (Parts)	有毒有害物质或元素					
	铅 (Pb)	汞 (Hg)	镉 (Cd)	六价铬 (Cr ⁶⁺)	多溴联 苯 (PBB)	多溴二苯 醚 (PBDE)
金属部件 (Metal Parts)	○	○	○	○	○	○
电路模块 (Circuit Modules)	X	○	○	○	○	○
电缆及电缆组件 (Cables and Cable Assemblies)	X	○	○	○	○	○
塑料和聚合物部件 (Plastic and Polymeric Parts)	○	○	○	○	○	○
光学和光学组件 (Optics and Optical Components)	○	○	○	○	○	○
电池 (Batteries)	○	○	○	○	○	○



○：表示该有毒有害物质在该部件所有均质材料中的含量均在 SJ/T11363-2006 标准规定的限量要求以下。

X：表示该有毒有害物质至少在该部件的某一均质材料中的含量超出 SJ/T11363-2006 标准规定的限量要求。

对所售之日的所售产品，本表表示，公司供应链的电子信息产品可能包含这些物质。注意：在所售产品中可能会也可能不会含有所有所列的部件。

This table was created to comply with China RoHS requirements for Motorola Solutions' AP6522 Access Point.



Motorola Solutions, Inc.
1301 E. Algonquin Rd.
Schaumburg, IL 60196-1078, U.S.A.
<http://www.motorolasolutions.com>

MOTOROLA, MOTO, MOTOROLA SOLUTIONS and the Stylized M Logo are trademarks or registered trademarks of Motorola Trademark Holdings, LLC and are used under license. All other trademarks are the property of their respective owners.
© 2013 Motorola Solutions, Inc. All Rights Reserved.



MN000035A01
Revision A September 2013

