

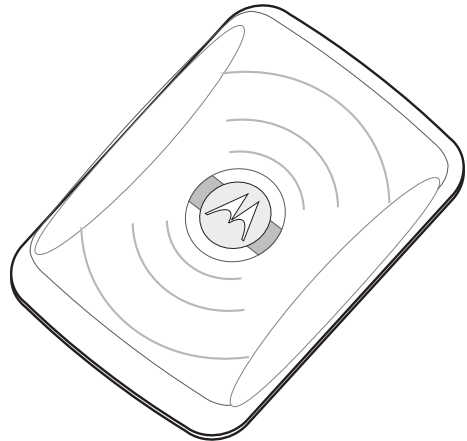

# AP6532 Series Access Point

## Installation Guide

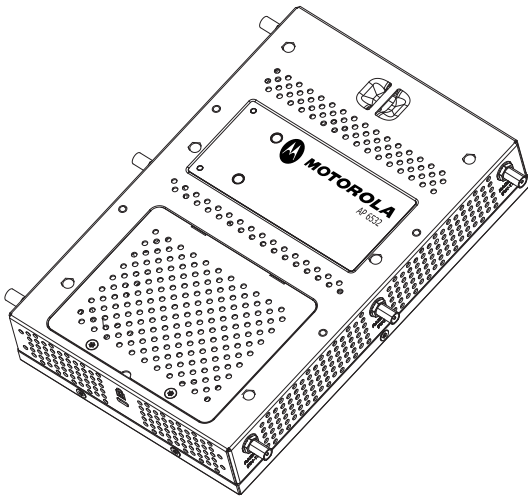

MOTOROLA and the Stylized M Logo are registered in the US Patent & Trademark Office. Symbol is a registered trademark of Symbol Technologies, Inc. All other product or service names are the property of their respective owners. © Motorola Solutions 2011. All rights reserved.

# Table of Contents

<b>1</b>	<b>Introduction .....</b>	<b>1</b>
1.1	Document Conventions .....	1
1.2	Warnings .....	1
1.3	Site Preparation.....	2
1.4	AP6532 Package Contents .....	2
1.4.1	External Antenna Model Package Contents .....	2
1.4.2	Integrated Antenna Model Package Contents.....	2
1.5	Features .....	3
<b>2</b>	<b>Hardware Installation .....</b>	<b>4</b>
2.1	Installation Instructions.....	4
2.2	Precautions .....	5
2.3	Access Point Placement .....	5
2.4	Integrated Antenna Model Wall Mount Instructions .....	5
2.4.1	Wall Mount Hardware .....	5
2.4.2	Wall Mount Procedure .....	7
2.5	Integrated Antenna Model Suspended Ceiling T-Bar Mount Instructions .....	9
2.5.1	Suspended Ceiling Mount Procedure.....	9
2.6	External Antenna Model Wall Mount Instructions .....	10
2.6.1	Wall Mount Hardware .....	10
2.6.2	Wall Mount Procedure .....	11
2.7	External Antenna Model Suspended Ceiling Tile (Plenum) Mount Instructions ..	12
2.7.1	Suspended Ceiling Mount Hardware.....	12
2.7.2	Ceiling Mount Procedure.....	13
2.8	AP6532 External Antenna Model Antenna Options.....	14
2.9	LED Indicators.....	15

<b>3</b>	<b>Defining a Basic Configuration .....</b>	<b>16</b>
3.1	Using the Initial Setup Wizard .....	16
<b>4</b>	<b>Specifications .....</b>	<b>37</b>
4.1	AP6532 External Antenna Model Electrical Characteristics .....	37
4.2	AP6532 External Antenna Model Physical Characteristics .....	37
4.3	AP6532 Integrated Antenna Model Electrical Characteristics .....	38
4.4	AP6532 Integrated Antenna Model Physical Characteristics .....	38
4.5	Radio Characteristics .....	39
<b>5</b>	<b>Regulatory Information.....</b>	<b>40</b>
5.1	Regulatory Information.....	40
5.2	Wireless Device Country Approvals.....	40
5.2.1	Country Selection .....	41
5.2.2	Frequency of Operation – FCC and IC .....	41
5.3	Health and Safety Recommendations.....	41
5.3.1	Warnings for Use of Wireless Devices.....	41
5.3.2	Potentially Hazardous Atmospheres – Fixed Installations .....	41
5.3.3	Safety in Hospitals .....	42
5.3.4	Pacemakers .....	42
5.3.5	Other Medical Devices .....	42
5.4	RF Exposure Guidelines .....	42
5.4.1	Safety Information.....	42
5.5	International .....	42
5.6	Europe.....	43
5.7	US and Canada .....	43
5.8	Power Supply.....	43
5.9	Radio Frequency Interference Requirements—FCC .....	44
5.10	Radio Frequency Interference Requirements – Canada .....	44
5.10.1	Radio Transmitters .....	44
5.11	CE Marking and European Economic Area (EEA) .....	45

5.12 Statement of Compliance.....	45
5.13 Waste Electrical and Electronic Equipment (WEEE).....	46
5.14 TURKISH WEEE Statement of Compliance.....	47
5.15 Japan (VCCI) - Voluntary Control Council for Interference.....	47
5.16 Korea Warning Statement for Class B ITE.....	48
5.17 Other Countries.....	48
5.17.1 Australia.....	48
5.17.2 Brazil.....	48
5.17.3 Chile.....	48
5.17.4 China.....	49
5.17.5 Mexico.....	49
5.17.6 South Korea.....	49
5.17.7 Taiwan.....	50
<b>6 Motorola Solutions Enterprise Mobility Support Center.....</b>	<b>51</b>
6.1 Customer Support Web Sites.....	51
6.2 Manuals.....	51
<b>7 AP6532 Series ROHS Compliance.....</b>	<b>52</b>

# 1 Introduction

The AP6532 Access Point, a component of the Motorola Solutions Wireless Controller System, links wireless 802.11a/b/g/n devices to the controller, enabling growth of your wireless network with a cost-effective alternative to standard Access Points. The AP6532 Access Point provides two placement options: wall and ceiling. Wall mount slots fit onto two provided screws. Arrows on the case guide the placement of the screws. For placement above a suspended ceiling, a safety wire tie point on the case provides for a safety wire loop. The light pipe fits through a hole in the ceiling tile to provide a view of the unit's status lights.

The AP6532 Access Point receives all power and transfers data through the same CAT-5 or better Ethernet cable. There is no additional power supply required. An 802.3af Ethernet switch or power injector is required.

## 1.1 Document Conventions

The following graphical alerts are used in this document to indicate notable situations:



**NOTE** Tips, hints, or special requirements that you should take note of.

---



**CAUTION** Care is required. Disregarding a caution can result in data loss or equipment malfunction.

---



**WARNING!** Indicates a condition or procedure that could result in personal injury or equipment damage.

---

## 1.2 Warnings

- Read all installation instructions and site survey reports, and verify correct equipment installation before connecting the AP6532 Access Point.
- Remove jewelry and watches before installing this equipment.
- Verify that the unit is grounded before connecting it to the power source.
- Verify that any device connected to this unit is properly wired and grounded.

- Verify there is adequate ventilation around the device, and that ambient temperatures meet equipment operation specifications.

### **1.3 Site Preparation**

- Consult your site survey and network analysis reports to determine specific equipment placement, power drops, and so on.
- Assign installation responsibility to the appropriate personnel.
- Identify and document where all installed components are located.
- Ensure adequate, dust-free ventilation to all installed equipment.
- Identify and prepare Ethernet and console port connections.
- Verify that cable lengths are within the maximum allowable distances for optimal signal transmission.

### **1.4 AP6532 Package Contents**

The AP6532 Access Point is available in integrated antenna and external antenna models. The contents of the package differ between the integrated antenna and external antenna model.

#### ***1.4.1 External Antenna Model Package Contents***

- AP6532 Access Point with external antenna connectors (Plenum Rated)
- Two wall mount screws
- Two wall anchors
- Light pipe
- Badge for light pipe
- AP6532 Installation Guide (This Guide)

#### ***1.4.2 Integrated Antenna Model Package Contents***

- AP6532 Access Point with integrated antennas
- Two wall mount screws
- Two wall anchors
- AP6532 Installation Guide (This Guide)

## 1.5 Features

- One RJ-45 connector
- LED indicators
- Safety wire tie point
- Slots for wall mounting
- Clips for mounting on a suspended ceiling T-bar
- Lock port for Kensington® style Security Lock

The AP6532 Access Point has one RJ-45 connector supporting an 10/100/1000 Ethernet port and requires 802.3af-compliant power from an external source.



**NOTE** When operating in a Gigabit Ethernet environment, CAT-5e or CAT-6 cable is recommended for Gigabit operation.

---

The AP6532 Access Point comes with dual radios both supporting 802.11a/b/g/n.

The Access Point contains runtime firmware which enables the unit to boot after a power up or watchdog reset. The runtime firmware on the Access Point and the firmware downloaded from the controller can be updated via the Ethernet interface from the Wireless Controller.



## 2 Hardware Installation

### 2.1 Installation Instructions

The AP6532 Access Point mounts either on a wall (with wide-shoulder screws) or on a suspended ceiling T-bar. This unit is not designed for mounting on a desk.

To prepare for the installation, perform the following:

1. Match the model number on the purchase order with the model numbers in the packing list and on the case of the device shipped.
2. Verify the contents of the box include the intended AP6532 Access Point and that the included hardware matches the package contents on page 2.

<b>Part Number</b>	<b>Description</b>
AP-6532-66030-US	802.11a/b/g/n dual radio integrated antenna configuration United States model
AP-6532-66030-OUS	802.11a/b/g/n dual radio integrated antenna configuration United States model for outdoor installation
AP-6532-66030-WW	802.11a/b/g/n dual radio integrated antenna configuration World Wide model
AP-6532-66040-US	802.11a/b/g/n dual radio external antenna configuration United States model
AP-6532-66040-OUS	802.11a/b/g/n dual radio external antenna configuration United States model for outdoor installation
AP-6532-66040-WW	802.11a/b/g/n dual radio external antenna configuration World Wide model



**NOTE** In the above part numbers, *XX* represents the 2-digit country code which specifies which country the model is designed for. A country code of “*WW*” represents a world wide model. The letter *O* preceding the 2-digit country code specifies the model is designed for outdoor installation.

3. Review site survey and network analysis reports to determine the location and mounting position for the AP6532 Access Point.

4. Connect a CAT-5 or better Ethernet cable to a compatible 802.3af power source and run the cable to the installation site. Ensure there is sufficient slack on the cable to perform the installation steps.



**NOTE** When operating in a Gigabit Ethernet environment, CAT-5e or CAT-6 cable is recommended for Gigabit operation.

---

## 2.2 Precautions

Before installing an AP6532 model Access Point, verify the following:

- Motorola Solutions recommends you do not to install the AP6532 in wet or dusty areas.
- Verify the environment has a continuous temperature range between 0° C to 50° C.

## 2.3 Access Point Placement

For optimal performance, install the Access Point away from transformers, heavy-duty motors, fluorescent lights, microwave ovens, refrigerators and other industrial equipment. Signal loss can occur when metal, concrete, walls or floors block transmission. Install the Access Point in an open area or add Access Points as needed to improve coverage.

Antenna coverage is analogous to lighting. Users might find an area lit from far away to be not bright enough. An area lit sharply might minimize coverage and create *dark areas*. Uniform antenna placement in an area (like even placement of a light bulb) provides even, efficient coverage.

Place the Access Point using the following guidelines:

- Install the Access Point at an ideal height of 10 feet from the ground.
- Orient the Access Point antennas vertically for best reception.

To maximize the Access Point's radio coverage area, Motorola Solutions recommends conducting a site survey to define and document radio interference obstacles before installing the Access Point.

## 2.4 Integrated Antenna Model Wall Mount Instructions

This mounting requires hanging the AP6532 Access Point along its width or length using the two slots on the bottom of the unit. The AP6532 can be mounted onto any plaster, wood, or cement wall surface using the provided wall anchors. The following illustration displays a lengthwise mount.

### 2.4.1 Wall Mount Hardware

- Two wide-shoulder Phillips pan head self-tapping screws

- Two wall anchors
- Security cable (optional)



**NOTE** In the event that the original mounting screws are lost, the following screws can be used instead: (ANSI Standard) #6-18 X 0.875in. Type A or AB Self-Tapping Screw, or (ANSI Standard Metric) M3.5 X 0.6 X 20mm Type D Self-Tapping Screw.

---

## 2.4.2 Wall Mount Procedure

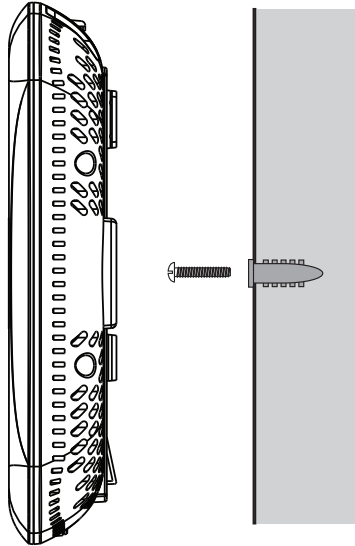

Integrated Antenna Wall Mount

1. Orient the case on the wall by its width or length.

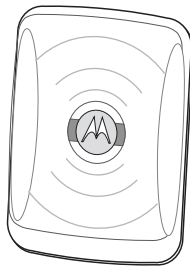

Correct Orientation

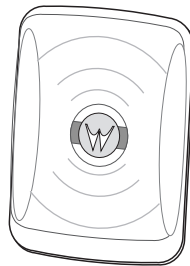

Incorrect Orientation



**CAUTION** To ensure proper operation of the AP6532 Access Point, ensure it is mounted in the correct orientation as shown above.

2. Using the arrows on one edge of the case as guides, move the edge to the midline of the mounting area and mark points on the midline for the screws.
3. At each point, drill a hole in the wall, insert an anchor, screw into the anchor the wall mounting screw and stop when there is 1mm between the screw head and the wall.



**NOTE** When pre-drilling a hole the recommended hole size is 2.8mm (0.11in.) if the screws are going directly into the wall and 6mm (0.23in.) if the provided wall anchors are being used.

---

4. If required, install and attach a security cable to the unit's lock port.
5. Attach the Ethernet cable to the unit and to a controller with an 802.3af-compatible power source.
6. Place the middle of each of the case's mount slots over the screw heads.
7. Slide the case down along the mounting surface to hang the mount slots on the screw heads.
8. Verify the unit has power by observing that the LEDs are lit or flashing.

## 2.5 Integrated Antenna Model Suspended Ceiling T-Bar Mount Instructions

Ceiling mount requires holding the AP6532 Access Point up against a T-bar of a suspended ceiling grid and twisting the case onto the T-bar.

### 2.5.1 Suspended Ceiling Mount Procedure

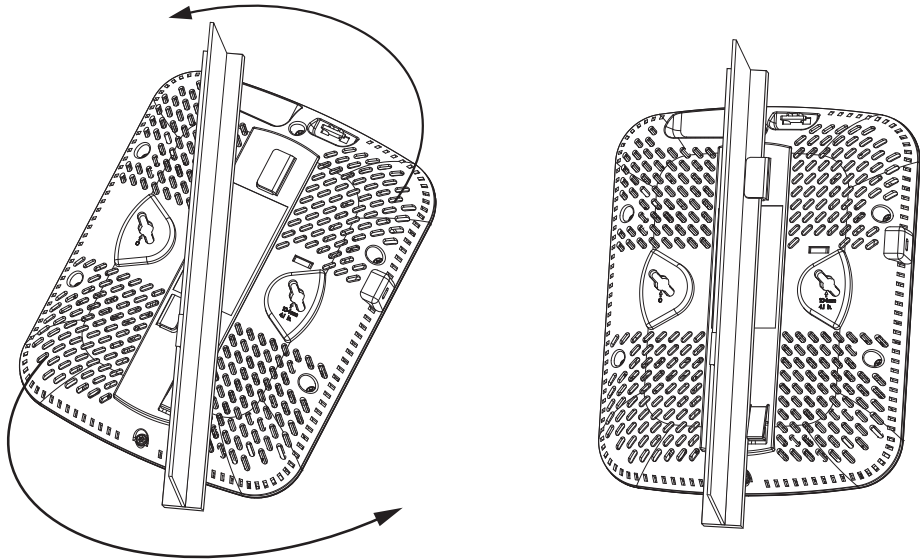

1. If required, install and attach a security cable to the unit's lock port.
2. Plug the Ethernet cable into the unit and to a controller with an 802.3af compatible power source.
3. Align the bottom of the T-bar with the back of the case.
4. Orient the case by its length, and the length of the T-bar.
5. Rotate the case 45 degrees clockwise, or about 10 o'clock.
6. Push the back of the case onto the bottom of the T-bar.
7. Rotate the case 45 degrees counter-clockwise. The clips click as they fasten to the T-bar.
8. Verify the unit has power by observing the LEDs.

## 2.6 External Antenna Model Wall Mount Instructions

Wall mounting requires hanging the AP6532 Access Point along its width or length using the pair of slots on the bottom of the unit. The AP6532 can be mounted onto any plaster, wood, or cement wall surface using the provided wall anchors. The following illustration shows a lengthwise mount.

### 2.6.1 Wall Mount Hardware

- Two wide-shoulder Phillips pan head self-tapping screws
- Two wall anchors
- Safety wire (recommended) and security cable (optional)



**NOTE** In the event the original mounting screws are lost, the following screws can be used: (ANSI Standard) #6-18 X 0.875in. Type A or AB Self-Tapping Screw, or (ANSI Standard Metric) M3.5 X 0.6 X 20mm Type D Self-Tapping Screw.

---

## 2.6.2 Wall Mount Procedure

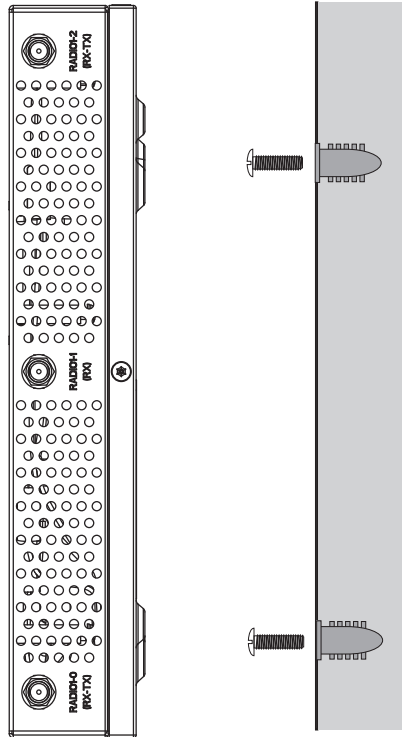

1. Orient the case on the wall by its width or length.
2. Using the arrows on one edge of the case as guides, move the edge to the midline of the mounting area and mark points on the midline for the screws.
3. At each point, drill a hole in the wall, insert an anchor, screw into the anchor the wall mounting screw and stop when there is 1mm between the screw head and the wall.



**NOTE** The recommended hole size is 2.8mm (0.11in.) if the screws are going directly into the wall, and 6mm (0.23in.) if the provided wall anchors are being used.

4. If required, loop a safety wire, between 1.5mm (.06in.) and 2.5mm (.10in.) in diameter, around the tie post and secure the loop.
5. If required, install and attach a security cable to the unit's lock port.



6. Place the large corner of each of the case's mount slots over the screw heads.
7. Slide the case down along the mounting surface to hang the mount slots on the screw heads.
8. Attach appropriate antennas to the connectors.
9. Attach the Ethernet cable to the unit and to a controller with an 802.3af compatible power source.
10. Verify the unit has power by observing that the LEDs are lit or flashing.

## 2.7 External Antenna Model Suspended Ceiling Tile (Plenum) Mount Instructions

Ceiling mount requires placing the AP6532 Access Point above a suspended ceiling and installing the provided light pipe for viewing the status lights of the unit.



**NOTE** Notes or warnings about suspended ceiling mounts apply to all installations where the unit is placed on suspended ceiling tile. The case has a safety wire tie point for a standard safety wire.

---



**CAUTION** Motorola Solutions does not recommend mounting the AP6532 Access Point directly to any suspended ceiling tile with a thickness less than 12.7mm (0.5in.) or a suspended ceiling tile with an unsupported span greater than 660mm (26in.). Motorola Solutions strongly recommends fitting the AP6532 Access Point with a safety wire suitable for the specific installation. The safety wire should be a standard ceiling suspension cable or equivalent steel wire between 1.59mm (.062in.) and 2.5mm (.10in.) in diameter.

---

This placement requires installation of the provided light pipe for viewing the status lights of the unit.

### 2.7.1 Suspended Ceiling Mount Hardware

- Light pipe
- Badge for light pipe
- Safety wire (recommended) and security cable (optional)

## 2.7.2 Ceiling Mount Procedure

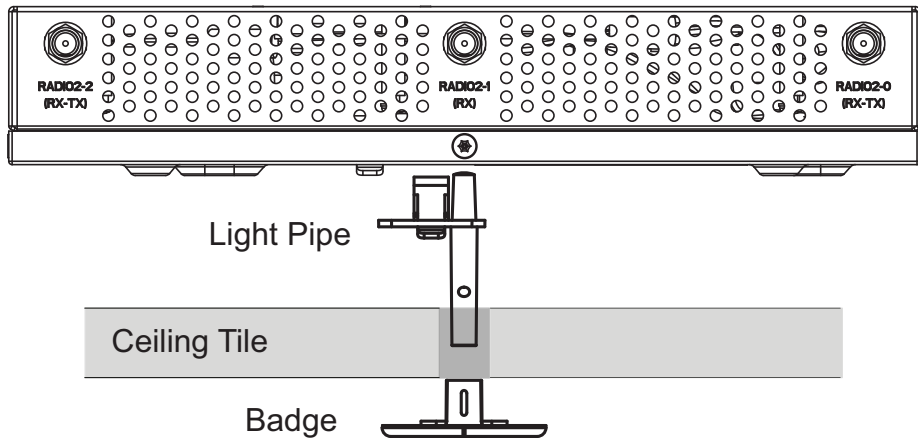

1. If possible, remove the ceiling tile from its frame and place it, finished side down, on a work surface.
2. If required, install a safety wire, between 1.5mm (.06in.) and 2.5mm (.10in.) in diameter, in the ceiling space.
3. If required, install and attach a security cable to the unit's lock port.
4. Mark a point on the upper or unfinished side of the tile.
5. Push the light pipe through the tile at the mark and remove the light pipe. If necessary, use a drill to make a hole in the tile.
6. Attach appropriate antennas to the connectors.
7. Snap the clips of the light pipe into the bottom of the case.
8. Fit the light pipe into hole in the tile from its unfinished side.
9. Attach any safety wire to the safety wire tie point or security cable to the unit's lock port.
10. Bring the tile into the ceiling space.
11. Plug the Ethernet cable into the unit and to a controller with an 802.3af compatible power source.
12. Verify the unit has power by observing the LEDs.
13. Place the ceiling tile back in its frame.
14. Snap the badge onto the light pipe from the finished side of the tile.

## 2.8 AP6532 External Antenna Model Antenna Options

Motorola Solutions supports two antenna suites for AP6532 External Antenna models. One antenna suite supporting the 2.4 GHz band and another antenna suite supporting the 5 GHz band. Select an antenna model best suited to the intended operational environment of your Access Point.

The 2.4 GHz antenna suite includes the following models:

<b><i>Part Number</i></b>	<b><i>Antenna Type</i></b>
ML-2452-APA2-01	Dipole Antenna
ML-2499-SD3-01R	Patch Antenna
ML-2499-HPA3-01R	Omni Antenna
ML-2452-PNA5-01R	Panel Antenna
ML-2452-PTA3M3-036	Omni Antenna

The 5 GHz antenna suite includes the following models:

<b><i>Part Number</i></b>	<b><i>Antenna Type</i></b>
ML-2452-APA2-01	Dipole Antenna
ML-5299-PTA1-01R	Patch Antenna
ML-5299-HPA1-01R	Omni Antenna
ML-2452-PNA5-01R	Panel Antenna
ML-2452-PTA3M3-036	Omni Antenna

For up-to-date information on supported antennas and antenna specifications, please see the Motorola Enterprise Wireless LAN Antenna Specification Guide available on the Motorola Solutions website.

## 2.9 LED Indicators

Both Integrated Antenna and External Antenna models have LED activity indicators on the front of the case. With the External Antenna models mounted above a ceiling, LEDs are at the center of an oval badge on the ceiling; a light pipe enables viewing the back LEDs through the ceiling tile.

The LEDs provide a status display indicating error conditions, transmission, and network activity for the 5 GHz 802.11a/n (amber) radio or the 2.4 GHz 802.11b/g/n (green) radio..

<b>Task</b>	<b>5 GHz Activity LED (Amber)</b>	<b>2.4 GHz Activity LED (Green)</b>
System Booting	Solid On (During start up only)	Solid On (During start up only)
Radio Shutdown Administratively or LEDs Disabled	Off	Off
Radio Not Configured or Country-code not set or WLAN not mapped to radio	Blink (On 2 seconds, Off 2 seconds)	Blink (On 2 seconds, Off 2 seconds)
Locate AP Mode	Off	Blinking

## 3 Defining a Basic Configuration

An AP6532 Series access point can utilize an initial setup wizard to streamline the process of initially accessing the wireless network. The wizard defines the access point's operational mode, deployment location, basic security, network and WLAN settings.

### 3.1 Using the Initial Setup Wizard

Once the AP6532 is installed and powered on, complete the following steps to get the access point up and running and access management functions:

1. The access point's IP address is optimally provided using DHCP. A zero config IP address can also be derived if DHCP resources are unavailable. Using zero config, the last two octets in the IP address are the decimal equivalent of the last two bytes in the access point's hardcoded MAC address.

For example:

MAC address - 00:C0:23:00:F0:0A

Zero-config IP address - 169.254.240.10

To derive the access point's IP address using its MAC address:

- a. Open the Windows calculator by selecting *Start > All Programs > Accessories > Calculator*. This menu path may vary slightly depending on your version of Windows.
  - b. With the Calculator displayed, select *View > Scientific*. Select the **Hex** radio button.
  - c. Enter a hex byte of the access point's MAC address. For example, F0.
  - d. Select the **Dec** radio button. The calculator converts F0 into 240. Repeat this process for the last access point MAC address octet.
2. Point the Web browser to the access point's IP address. The following login screen displays:

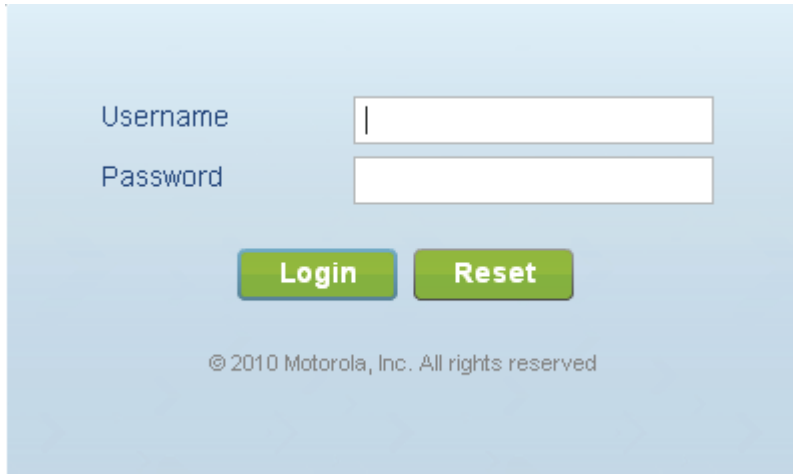

A screenshot of a login interface on a light blue background. It features two input fields: 'Username' and 'Password'. Below the fields are two green buttons labeled 'Login' and 'Reset'. At the bottom, there is a copyright notice: '© 2010 Motorola, Inc. All rights reserved'.

3. Enter the default username ***admin*** in the **Username** field.
4. Enter the default password ***motorola*** in the **Password** field.
5. Click the **Login** button to load the management interface.



**NOTE** When logging in for the first time, you're prompted to change the password to enhance device security in subsequent logins.



**NOTE** If you get disconnected when running the wizard, you can connect again with the access point's actual IP address (once obtained) and resume the wizard.

---



## Initial Setup Wizard

An initial setup wizard is available to aid in configuring a simple WLAN deployment. The wizard will guide configuration of the following features:

1. Location, country, and time zone
2. Bridge or Router operation
3. WLAN configuration
4. AP discovery

Would you like to use the wizard?

**Start Wizard**

**Not Now**

**Never**

6. If this is the first time the management interface has been accessed, a dialogue displays to start the wizard. Select **Start Wizard** to run the initial setup wizard.

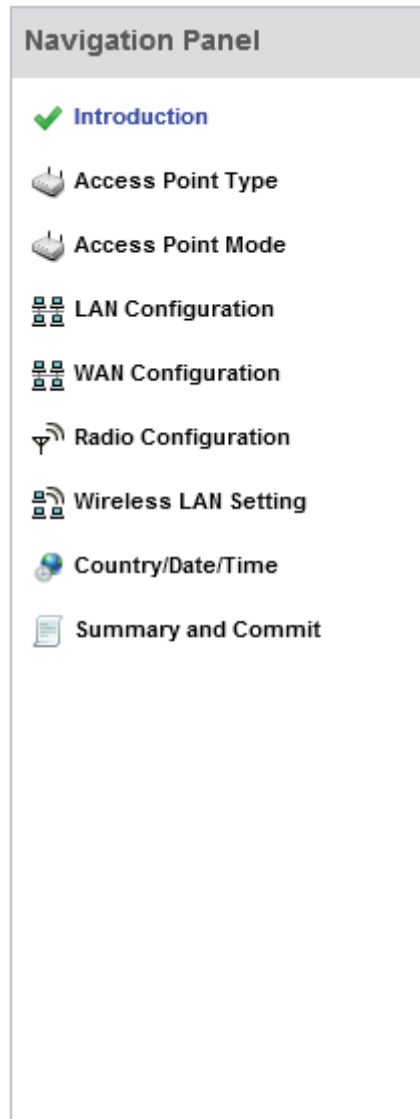

The first page of the Initial AP Setup Wizard displays the *Navigation Panel* and *Introduction* for the configuration activities comprising the access point's initial setup



A green checkmark to the left of an item in the Navigation Panel defines the listed task as having its minimum required configuration parameters set correctly. A red X defines the task as still requiring at least one parameter be defined correctly.

The Introduction screen displays a list of the basic configuration activities supported by the Initial Setup Wizard.

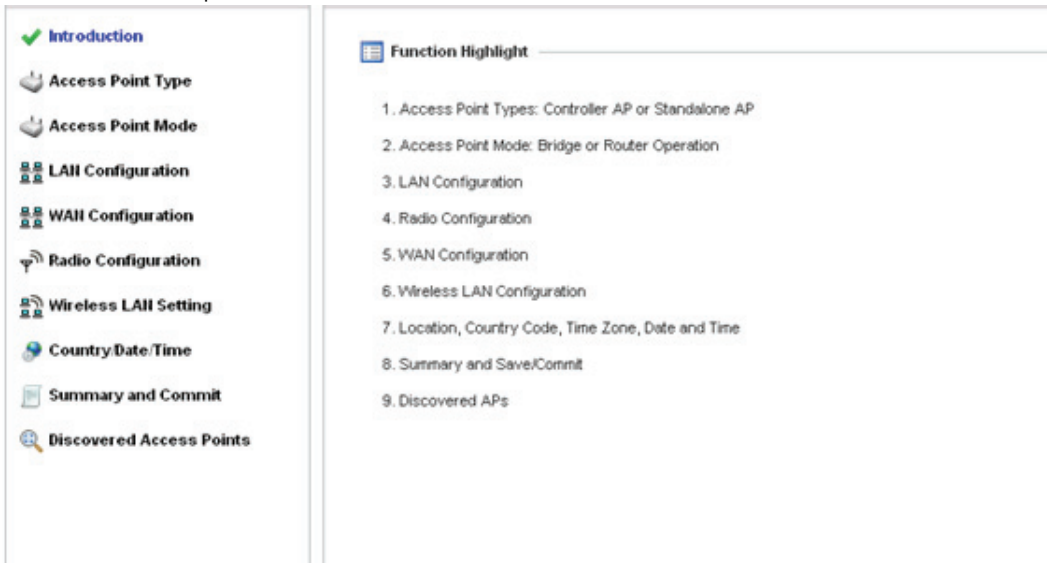











7. Select **Save/Commit** within each page to save the updates made to that page's configuration. Select **Next** to proceed to the next page listed in the Navigation Panel. Select **Back** to revert to the previous screen in the Navigation Panel without saving your updates.



**NOTE** While you can navigate to any page in the navigation panel, you cannot complete the Initial AP Setup Wizard until each task in the Navigation Panel has a green checkmark.

8. Select **Next**. The Initial AP Setup Wizard displays the **Access Point Type** screen to define the access point's Standalone versus Virtual Controller AP functionality and the way the access point is adopted to a controller.

Navigation Panel	Access Point Type
<ul style="list-style-type: none"> <li> Introduction</li> <li> Access Point Type</li> <li> Access Point Mode</li> <li> LAN Configuration</li> <li> WAN Configuration</li> <li> Radio Configuration</li> <li> Wireless LAN Setting</li> <li> Country/Date/Time</li> <li> Summary and Commit</li> <li> Discovered Access Points</li> </ul>	<p data-bbox="503 318 752 339"> Access Point Type Selection</p> <ul style="list-style-type: none"> <li data-bbox="538 378 1121 443"><input checked="" type="radio"/> Controller AP - When more than one access point is deployed, a single access point can function as a Controller AP and manage Dependent mode access points. Up to 24 Dependant APs can be connected to a Controller AP.</li> <li data-bbox="538 482 1112 547"><input type="radio"/> Standalone AP - Select this option to deploy this access point as an autonomous "fat" access point. A standalone AP isn't managed by a Controller AP, or adopted by a controller.</li> <li data-bbox="538 586 1121 716"><input type="radio"/> Dependent AP - Select this option when deploying the access point as a controller managed access point. Selecting this option closes the Initial Setup Wizard. A Dependant AP obtains its configuration from a profile stored on the Controller AP. Any manual configuration changes on a Dependant AP are overwritten by the Controller AP upon reboot. A Dependent AP requires a Controller AP in the network.</li> </ul>
<input type="button" value="Back"/> <input type="button" value="Next"/> <input type="button" value="Save/Commit"/>	

9. Select an **Access Point Type** from the following options:

- *Virtual Controller AP* - When more than one access point is deployed, a single access point can function as a Virtual Controller AP. Up to 24 access points can be connected to, and managed by, a single Virtual Controller AP of the same AP6532 model.
- *Standalone AP* - Select this option to deploy this access point as an autonomous fat access point. A Standalone AP isn't managed by a Virtual Controller AP, or adopted by a RFS series controller.



**NOTE** If designating the access point as a Standalone AP, Motorola Solutions recommends the access point's UI be used exclusively to define its device configuration, and not the CLI. The CLI provides the ability to define more than one profile and the UI does not. Consequently, the two interfaces cannot be used collectively to manage profiles without an administrator encountering problems.

- *Adopted to Controller* - Select this option when deploying the access point as a controller managed (Dependent mode) access point. Selecting this option closes the Initial AP Setup Wizard. An adopted access point obtains its configuration from a profile stored on its managing controller. Any manual configuration changes are overwritten by the controller upon reboot.

Select the *Automatic controller discovery* option to enable the access point to be discovered and adopted using layer 2 settings. If preferring layer 3 adoption, select the *Static Controller Configuration* option, and define the addresses of the preferred controllers. If using the static method, you'll also need to define whether the access point receives an IP address using DHCP or if IP resources are provided statically.

#### Adoption Settings

Automatic controller discovery (L2, DHCP or DNS based)

Static Controller Configuration

Controller 1 \* 172.168.0.20

Controller 2

#### AP IP Address

Use DHCP  Static IP Address/Subnet \* 192.168.0.1 / 24

Default Gateway \* 192.168.0.1

10. Select **Next**. The Initial AP Setup Wizard displays the **Access Point Mode** screen to define the access point's routing or bridging mode functionality.

**Navigation Panel**

- ✓ Introduction
- ✓ Access Point Type
- 📁 Access Point Mode
- 📁 LAN Configuration
- 📁 WAN Configuration
- 📁 Radio Configuration
- 📁 Wireless LAN Setting
- 🌐 Country/Date/Time
- 📄 Summary and Commit
- 🔍 Discovered Access Points

**Access Point Mode**

📁 Access Point Mode Selection

Router Mode - In Router Mode, the access point routes traffic between the local network(LAN) and the Internet or external network (WAN). Router mode is recommended in a deployment supported by just a single access point.



Bridge Mode - In Bridge Mode, the access point depends on an external router for routing LAN and WAN traffic. Routing is generally used on one device, whereas bridging is typically used in a larger density network. Thus, select Bridge Mode when deploying this access point with numerous peer APs supporting clients on both the 2.4 and 5GHz radio bands.

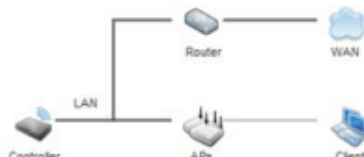

Back Next Save/Cancel

11. Select an **Access Point Mode** from the available options.

- *Router Mode* - In Router Mode, the access point routes traffic between the local network (LAN) and the Internet or external network (WAN). Router mode is recommended in a deployment supported by just a single access point.
- *Bridge Mode* - In Bridge Mode, the AP depends on an external router for routing LAN and WAN traffic. Routing is generally used on one device, whereas bridging is typically used in a larger network. Thus, select Bridge Mode when deploying this access point with numerous peer APs supporting clients on both the 2.4 and 5GHz radio bands.

12. Select **Next**. The Initial AP Setup Wizard displays the **LAN Configuration** screen to set the access point's LAN interface configuration.

Navigation Panel	LAN Configuration
<ul style="list-style-type: none"><li><input checked="" type="checkbox"/> Introduction</li><li><input checked="" type="checkbox"/> Access Point Type</li><li><input checked="" type="checkbox"/> Access Point Mode</li><li><input checked="" type="checkbox"/> LAN Configuration</li><li><input type="checkbox"/> WLAN Configuration</li><li><input type="checkbox"/> Radio Configuration</li><li><input type="checkbox"/> Wireless LAN Setting</li><li><input type="checkbox"/> Country/Date/Time</li><li><input type="checkbox"/> Summary and Commit</li><li><input type="checkbox"/> Discovered Access Points</li></ul>	<h3 data-bbox="448 305 619 326">LAN Configuration</h3> <p data-bbox="468 358 1053 427"><input type="radio"/> Use DHCP <a href="#">What is this?</a> <input checked="" type="radio"/> Static IP Address/Subnet <a href="#">What is this?</a> * <input type="text" value="0 . 0 . 0 . 0 / 24"/></p> <h4 data-bbox="529 475 625 496">DHCP Server</h4> <p data-bbox="547 513 937 534"><input type="checkbox"/> Use device to assign IP addresses to wireless clients</p> <p data-bbox="547 553 1053 574">Range <input .="" ."="" type="text" value="."/> -- <input .="" ."="" type="text" value="."/></p> <p data-bbox="547 594 851 615">Default Gateway <input .="" ."="" type="text" value="."/></p> <h4 data-bbox="529 680 735 701">Domain Name Server (DNS)</h4> <p data-bbox="547 717 851 738">Primary DNS <input .="" ."="" type="text" value="."/></p> <p data-bbox="547 758 851 779">Secondary DNS <input .="" ."="" type="text" value="."/></p>
<input type="button" value="Back"/> <input type="button" value="Next"/> <input type="button" value="Save/Commit"/>	

13. Set the following DHCP and Static IP Address/Subnet information for the LAN interface:
  - *Use DHCP* - Select the checkbox to enable an automatic network address configuration using the access point's DHCP server. An AP6532 access point does not have an onboard DHCP server and an external DHCP server must be utilized.
  - *Static IP Address/Subnet* - Enter an IP Address and a subnet for the access point's LAN interface. If Use DHCP is selected, this field is not available. When selecting this option, define the following *DHCP Server* and *Domain Name Server (DNS)* resources, as those fields will become enabled on the bottom portion of the screen.
    - *Use on-board DHCP server to assign IP addresses to wireless clients* - Select the checkbox to enable the access point's DHCP server to provide IP and DNS information to clients on the LAN interface.
    - *Range* - Enter a starting and ending IP Address range for client assignments on the access point's LAN interface. Avoid assigning IP addresses from x.x.x.1 - x.x.x.10 and x.x.x.255, as they are often reserved for standard network services. This is a required parameter.
    - *Default Gateway* - Define a default gateway address for use with the default gateway. This is a required parameter.
  - *DNS Forwarding* - Select this option to allow a DNS server to translate domain names into IP addresses. If this option is not selected, a primary and secondary DNS resource must be specified. DNS forwarding is useful when a request for a domain name is made but the DNS server, responsible for converting the name into its corresponding IP address, cannot locate the matching IP address.
    - *Primary DNS* - Enter an IP Address for the main Domain Name Server providing DNS services for the access point's LAN interface.
    - *Secondary DNS* - Enter an IP Address for the backup Domain Name Server providing DNS services for the access point's LAN interface
14. Select **Next**. The Initial AP Setup Wizard displays the **WAN Configuration** screen to set the access point's WAN interface configuration.

Navigation Panel	WAN Configuration
<ul style="list-style-type: none"> <li>✓ Introduction</li> <li>✓ Access Point Type</li> <li>✓ Access Point Mode</li> <li>✓ LAN Configuration</li> <li>✓ <b>WAN Configuration</b></li> <li>✓ Radio Configuration</li> <li>Wireless LAN Setting</li> <li>Country/Date/Time</li> <li>Summary and Commit</li> <li>Discovered Access Points</li> </ul>	<p><b>WAN Configuration</b></p> <p> <input checked="" type="radio"/> Use DHCP <a href="#">What is this?</a> </p> <p> <input type="radio"/> Static IP Address/Subnet <input type="text" value="0 . 0 . 0 . 0 / 24"/> <a href="#">What is this?</a> </p> <p>           Default Gateway <input type="text" value=""/> </p> <p>           Port to connect to the external network <input type="text" value="fe2"/> </p> <p> <input checked="" type="checkbox"/> Enable NAT on the WAN interface <a href="#">What is this?</a> </p>
	<input type="button" value="Back"/> <input type="button" value="Next"/> <input type="button" value="Save/Co"/>

15. Set the following DHCP and Static IP Address/Subnet information for the WAN interface:

- *Use DHCP* - Select the checkbox to enable an automatic network address configuration using the access point's DHCP server.
- *Static IP Address/Subnet* - Enter an IP Address/Subnet and gateway for the access point's WAN interface. These are required fields
- *The port connected to the WAN* - Select the port used as the physical access point connection to the external network. This ports available differ depending on the access point model deployed. Access point models with a single port have this option fixed.
- *Enable NAT on the WAN Interface* - Select the checkbox to allow traffic to pass between the access point's WAN and LAN interfaces.

16. Select **Next**. The Initial AP Setup Wizard displays the **Radio Configuration** screen to define support for the 2.4GHz radio band, 5GHz radio band or to set the radio's functionality as a dedicated sensor. An AP6532 supports a single dual-band radio.



**NOTE** The **ADSP Sensor Support** field displays at the bottom of the screen only if a radio has been dedicated as a sensor.

---



 **Radio 1**

---

**Configure as a Data Radio** [What is this?](#)

Radio Frequency Band  2.4GHz  5.0GHz

Power Level   (1 – 23) Channel Mode    Constantly Monitor

**Configure as a Sensor Radio** [What is this?](#)

**Disable the Radio** Radio 1 will be disabled. Please make sure this is what you want to do.

---

---

**Back**

**Next**

**Save/Comm**

17. Set the following parameters for the radio:

- *Configure as a Date Radio* - Select this option to dedicate this radio for WLAN client support in either the selected 2.4 or 5GHz radio band.

- *Radio Frequency Band* - Select either the 2.4GHz or 5.0GHz radio band to use with the radio when selected as a Data Radio. The selected band is used for WLAN client support. Considers selecting one radio for 2.4GHz and another for 5GHz support (if using a dual or three radio model) when supporting clients in both the 802.11bg and 802.11n bands.
- *Power Level* - Use the spinner control to select a 1 - 23 dBm minimum power level to assign to this radio in selected 2.4 or 5.0 GHz band. 1 dBm is the default setting.
- *Channel Mode* - Select either *Random*, *Best* or *Static*. Select **Random** for use with a 802.11a/n radio. To comply with *Dynamic Frequency Selection* (DFS) requirements in the European Union, the 802.11a/n radio uses a randomly selected channel each time the access point is powered on.  
Select **Best** to enable the access point to scan non-overlapping channels and listen for beacons from other access points. After the channels are scanned, it will select the channel with the fewest access points. In the case of multiple access points on the same channel, it will select the channel with the lowest average power level.  
When **Constantly Monitor** is selected, the access point will continuously scan the network for excessive noise and sources of interference. Select **Static** to assign the access point a permanent channel and scan for noise and interference only when initialized.
- *Configure as a Sensor Radio* - Select this option to dedicate the radio to sensor support exclusively. When functioning as a sensor, the radio scans in sensor mode across all channels within the 2.4 and 5.0GHz bands to identify potential threats within the access point managed network. If dedicating a radio as a sensor resource, a primary and secondary ADSP server must be specified as an ADSP management resource.



**NOTE** If configuring an AP6532 model access point as a sensor, the access point will require a reboot before its sensor functionality is invoked. The reboot can take place at the completion of the Initial AP Setup Wizard.

---

- *Disable the Radio* - Select this option to disable this radio, thus prohibiting it from either providing WLAN or sensor support. Verify this course action with your network administrator before rendering the radio offline.
18. Select **Next**. The Initial AP Setup Wizard displays the **Wireless LAN Setting** screen to define network address and security settings for two WLAN configurations available to the access point as part of the Initial AP Setup Wizard. Once the access point has an initial configuration defined, numerous additional WLAN configurations can be set.

**Navigation Panel**

- ✓ Introduction
- ✓ Access Point Type
- ✓ Access Point Mode
- ✓ LAN Configuration
- ✓ WLAN Configuration
- ✓ Radio Configuration
- ✗ **Wireless LAN Setting**
- 🌐 Country/Date/Time
- 📄 Summary and Commit
- 🔍 Discovered Access Points

### Wireless LAN Setting

WLAN 1
WLAN 2

**WLAN 1 Configuration**

SSID \*  [What is this?](#)

WLAN Type

No Authentication and No Encryption [What is this?](#)

Captive Portal Authentication and No Encryption [What is this?](#)

PSK authentication, WPA2 encryption [What is this?](#)

EAP Authentication and WPA2 Encryption [What is this?](#)

WPA Key \*  ASCII ▼

(Enter 64 HEX or 8-63 ASCII Characters)

Back
Next
Save/Co

19. Set the following parameters for each of the two WLAN configurations available as part of this Initial AP Setup Wizard:

- *SSID* - Enter or modify the *Services Set Identification* (SSID) associated with the WLAN. The WLAN name is auto-generated using the SSID until changed by the user. The maximum number of characters is 32. Do not use < > | " & \ ? , This is a required parameter for each WLAN.
- *WLAN Type* - Set the data protection scheme used by clients and access points within the WLAN. The following options are available:
  - *No Authentication and no Encryption* - Select this option to provide no security between the access point and connected clients on this WLAN.
  - *Captive Portal Authentication and No Encryption* - Select this option to use a Web page (either internally or externally hosted) to authenticate users before access is

granted to the network. If using this option, define whether a local or external RADIUS authentication resource is used.

- *PSK Authentication and WPA2 Encryption* - Select the option to implement a pre-shared key that must be correctly shared between the access point and requesting clients using this WLAN. If using this option, specify a WPA key in either ASCII (8-63 characters) or HEX (64 characters) format.
- *EAP Authentication and WPA2 Encryption* - Select this option to authenticate clients within this WLAN through the exchange and verification of certificates. If using this option, define whether a local or external RADIUS authentication resource is used.
- *WPA Key* - If a WPA key is required (PSK Authentication and WPA2 Encryption), enter an alphanumeric string of 8 to 63 ASCII characters or 64 HEX characters as the primary string both transmitting and receiving authenticators must share. The alphanumeric string allows character spaces. This passphrase saves the administrator from entering the 256-bit key each time keys are generated.
- *RADIUS Server* - If the WLAN type requires a RADIUS server to validate user credentials, designate whether the access point is using an **External RADIUS Server** resource or the access point's own **Onboard RADIUS Server**. If using an external RADIUS server resource, provide the IP address of the external server and the shared secret used to authenticate the request.



**NOTE** If using the access point's onboard RADIUS server, an additional **RADIUS Server Configuration** screen displays within the Navigation Panel on the left-hand side of the screen. Use this screen to create user accounts validated when the access point authenticates client connection requests to the onboard RADIUS server.

---

20. Select **Next**. The Initial AP Setup Wizard displays the **RADIUS Server Configuration** screen if the access point's onboard RADIUS server is required to validate user requests. If an onboard RADIUS server is not required, the Initial AP Setup Wizard displays the **Country/Date/Time** screen to set device deployment, administrative contact and system time information.

### Navigation Panel

- ✔ Introduction
- ✔ Access Point Type
- 🔌 Access Point Mode
- 📶 LAN Configuration
- 📶 WLAN Configuration
- ✔ Radio Configuration
- ✔ Wireless LAN Setting
- ✔ **RADIUS Server Configuration**
- ✘ Country/Date/Time
- 📄 Summary and Commit
- 🔍 Discovered Access Points

### RADIUS Server Configuration

Some WLANs require authentication using the on-board RADIUS server. User accounts must be added if should be authorized by the server.

Username	Description

#### Add On-Board RADIUS Server Users

Username ✘

Password ✘

Confirm Password ✘

Description

Add User
Modify User
Reset

Back
Next
Save/Co

21. Refer to the *Username*, *Password*, *Description* and *Actions* columns to review credentials of existing RADIUS Server user accounts. Add new accounts or edit the properties of existing accounts as updates are required.
22. Refer to the **Add On-Board RADIUS Server Users** field to set the following parameters for a user account:
  - *Username* - If adding a new user account, create a username up to X characters in length. The username cannot be revised if modifying the user configuration. This is a required parameter.
  - *Password* - Provide (or modify) a password between X - X characters in length entered each time a requesting client attempts access to the AP managed network using the access point's onboard RADIUS server. This is a required parameter.

- *Confirm Password* - Re-enter (or modify) the password as a means of confirming the password. This is a required parameter.
  - *Description* - Optionally provide a description of the user account as means of further differentiating it from others.
23. When completed, select **Add User** to commit a new user, **Modify User** to commit a modified user or **Reset** to clear the screen without updating the configuration. Selecting Reset clears the field of all entered user account information.
  24. Select **Next**. The Initial AP Setup Wizard displays the **Country/Date/Time** screen to set device deployment, administrative contact and system time information. The system time can either be set manually or be supplied by a dedicated *Network Time Protocol* (NTP) resource.

**Navigation Panel**

- Introduction
- Access Point Type
- Access Point Mode
- LAN Configuration
- WLAN Configuration
- Radio Configuration
- Wireless LAN Setting
- Country/Date/Time**
- Summary and Commit
- Discovered Access Points

**Country/Date/Time**

---

**Country and Time Zone**

Location

Contact

Country \*

Time Zone \*

---

**System Date and Time**

:     AM  PM

---

**Network Time Protocol (NTP)**

NTP Server Address

(An external NTP server to provide system date and time)

25. Refer to the **Country and Time Zone** field to set the following device deployment information:

- *Location* - Define the location of the access point. The Location parameter acts as a reminder of where the AP can be located within the Motorola Solutions managed wireless network.
- *Contact* - Specify the contact information for the administrator. The credentials provided should accurately reflect the individual responding to service queries.
- *Country* - Select the Country where the access point is deployed. The access point prompts for the correct country code on the first login. A warning message also displays stating an incorrect country setting may result in illegal radio operation. Selecting the correct country is central to legal operation. Each country has its own regulatory restrictions concerning electromagnetic emissions and the maximum RF signal strength

that can be transmitted. This is a required parameter.

- *Time Zone* - Set the time zone where the access point is deployed. This is a required parameter. The setting should be complimentary with the selected deployment country.
26. If an NTP resource is unavailable, set the **System Date and Time** (calendar date, time and AM/PM designation).
  27. Optionally enter the IP address of a server used to provide system time to the access point. Once the IP address is entered, the **Network Time Protocol (NTP)** functionality is engaged automatically for synchronization with the NTP resource.
  28. If an NTP resource is unavailable, set the **System Date and Time** (calendar date, time and AM/PM designation).
  29. Optionally enter the IP address of a server used to provide system time to the access point. Once the IP address is entered, the **Network Time Protocol (NTP)** functionality is engaged automatically for synchronization with the NTP resource.
  30. Select **Next**. The Initial AP Setup Wizard displays the **Summary and Commit** screen to summarize the screens (pages) and settings updated using the Initial AP Setup Wizard.

There's no user intervention or additional settings required within this screen. Its an additional means of validating the configuration before its deployed. However, if a screen displays settings not intended as part of the initial configuration, the screen can be selected from within the Navigation Panel and its settings modified accordingly.



The screenshot displays the configuration interface for an AP6532 Series Access Point. It is divided into two main sections: a Navigation Panel on the left and a Summary and Commit page on the right.

**Navigation Panel:** This panel contains a list of configuration steps, each with a status icon:

- Introduction (Green checkmark)
- Access Point Type (Grey icon)
- Access Point Mode (Grey icon)
- LAN Configuration (Blue icon)
- WAN Configuration (Blue icon)
- Radio Mappings (Grey icon)
- Wireless LAN Setting (Blue icon)
- SMART RF Policy (Green checkmark)
- Country/Date/Time (Red X)
- Summary and Commit (Green checkmark)
- Discovered Access Points (Magnifying glass icon)

**Summary and Commit Page:** This page provides a summary of the current configuration settings:

- Access Point Type Page:** Access Point Type is set to Controller AP.
- Access Point Mode Page:** Access Point Mode is set to Router Mode.
- LAN Configuration Page:** LAN Configuration Type is set to Use DHCP.
- WAN Configuration Page:** WAN Configuration Type is set to Use DHCP, and Port to External is set to GE2 Port.
- Radio Mapping Page:** Radio 1 is configured as a Data Radio, and Radio1 Frequency Band is set to Configure 2.4GHz.
- WLAN Configuration Page:** Shows vLAN 1 Configuration, SSID, vLAN Type (No Authentication and No Encryption), and vLAN 2 Configuration.

At the bottom right of the interface, there are three buttons: **Back**, **Next**, and **Save/Commit**.

31. If the configuration displays as intended, select the **Save/Commit** button to implement these settings to the access point's configuration. If additional changes are warranted based on the summary, either select the target page from the Navigational Panel, or use the **Back** and **Next** buttons to scroll to the target screen.

## 4 Specifications

### 4.1 AP6532 External Antenna Model Electrical Characteristics

An AP6532 External Antenna model Access Point has the following electrical characteristics:

Operating Current & Voltage	180ma- 270ma @ 48VDC using Power over Ethernet
-----------------------------	--

### 4.2 AP6532 External Antenna Model Physical Characteristics

An AP6532 External Antenna model Access Point has the following physical characteristics:

Dimensions	8.50 in. Depth x 5.5 in. Width x 1.5 in. Height 21.59 cm Depth x 13.97 cm Width x 3.81 cm Height
Housing	Metal
Weight	2.5 lbs / 1.13 kg
Operating Temperature	32°F to 122°F/0°C to 50°C
Storage Temperature	-40°F to 158°F/-40°C to 70°C
Operating Humidity	5 to 95% Relative Humidity non-condensing
Storage Humidity	85% Relative Humidity non-condensing
Operating Altitude (max)	8,000 ft @ 28C
Storage Altitude (max)	30,000 ft @ 12C
Electrostatic Discharge	+/-15kV Air and +/-8kV Contact @ 50% Relative Humidity

### **4.3 AP6532 Integrated Antenna Model Electrical Characteristics**

An AP6532 Integrated model Access Point has the following electrical characteristics:

Operating Current & Voltage      180ma- 270ma @ 48VDC using Power over Ethernet

### **4.4 AP6532 Integrated Antenna Model Physical Characteristics**

An AP6532 Integrated Antenna model Access Point has the following physical characteristics:

Dimensions	9.50 in. Depth x 7.5 in. Width x 1.9 in. Height 24.13 cm Depth x 19.05 cm Width x 4.83 cm Height
Housing	Plastic
Weight	2.0 lbs / 0.91 kg
Operating Temperature	32°F to 122°F/0°C to 50°C
Storage Temperature	-40°F to 158°F/-40°C to 70°C
Operating Humidity	5 to 95% Relative Humidity non-condensing
Storage Humidity	85% Relative Humidity non-condensing
Operating Altitude (max)	8,000 ft @ 28C
Storage Altitude (max)	30,000 ft @ 12C
Electrostatic Discharge	+/-15kV Air and +/-8kV Contact @ 50% Relative Humidity

## 4.5 Radio Characteristics

The AP6532 model Access Points have the following radio characteristics:

Operating Channels	All channels from 4920 MHz to 5825 MHz except channel 52 -64 Channels 1-13 (2412-2472 MHz) Channel 14 (2484 MHz) Japan only Actual operating frequencies depend on regulatory approval for the country of use.
Data Rates Supported	802.11b: 1,2,5.5,11Mbps 802.11g: 1,2,5.5,11,6,9,12,18,24,36,48, and 54Mbps 802.11a: 6,9,12,18,24,36,48, and 54Mbps 802.11n: MCS 0-15 up to 300Mbps
Wireless Medium	<i>Direct Sequence Spread Spectrum (DSSS), Orthogonal Frequency Division Multiplexing (OFDM) Spatial multiplexing (MIMO)</i>
Network Standards	802.11a, 802.11b, 802.11g, 802.3, 802.11n (Draft 2.0)
Maximum Available Transmit Power	Maximum available conducted transmit power per chain: 2.4 GHz: 21dBm Maximum available conducted transmit power all chains: 2.4 GHz: 24dBm Maximum available conducted transmit power per chain: 5 GHz: 19dBm Maximum available conducted transmit power all chains: 5 GHz: 22dBm
Transmit Power Adjustment	1dB increments
Antenna Configuration	2x3 MIMO (transmit on two and receive on all three antennas)

## 5 Regulatory Information

### 5.1 Regulatory Information

This device is approved under the Symbol Technologies, Inc. brand: Symbol Technologies, Inc. is a wholly owned subsidiary of Motorola Solutions, Inc. (collectively "Motorola").

This guide applies to Model Number AP-0650

All Motorola/Symbol devices are designed to be compliant with rules and regulations in locations they are sold and will be labeled as required.

Local language translations are available at the following website:

<http://supportcentral.motorola.com/>

Any changes or modifications to Motorola/Symbol Technologies equipment, not expressly approved by Motorola/Symbol Technologies, could void the user's authority to operate the equipment.

Motorola/Symbol devices are professionally installed, the Radio Frequency Output Power will not exceed the maximum allowable limit for the country of operation.

Antennas: Use only the supplied or an approved replacement antenna. Unauthorized antennas, modifications, or attachments could cause damage and may violate regulations.

This device is only to be used with a Motorola/Symbol Technologies Wireless Switch.

### 5.2 Wireless Device Country Approvals

Regulatory markings, subject to certification, are applied to the device signifying the radio(s) is/are approved for use in the following countries: United States, Canada, Japan, China, S. Korea, Australia, and Europe.

Please refer to the Declaration of Conformity (DoC) for details of other country markings. This is available at: <http://www.motorola.com/doc>

**Note:** For 2.4GHz or 5GHz Products: Europe includes, Austria, Belgium, Bulgaria, Czech Republic, Cyprus, Denmark, Estonia, FinlFor 2.4GHz or 5GHz Products: Europe includes, Austria, Belgium, Bulgaria, Czech Republic, Cyprus, Denmark, Estonia, Finland, France, Germany, Greece, Hungary, Iceland, Ireland, Italy, Latvia, Liechtenstein, Lithuania, Luxembourg, Malta, Netherlands, Norway, Poland, Portugal, Romania, Slovak Republic, Slovenia, Spain, Sweden, Switzerland and the United Kingdom.



Operation of the device without regulatory approval is illegal.

### 5.2.1 Country Selection

Select only the country in which you are using the device. Any other selection will make the operation of this device illegal.

### 5.2.2 Frequency of Operation – FCC and IC

#### 5 GHz Only

The use in the UNII (Unlicensed National Information Infrastructure) band 1 (5150-5250 MHz) is restricted to Indoor Use Only; any other use will make the operation of this device illegal.

#### Industry Canada Statement:

**Caution:** The device for the band 5150-5250 MHz is only for indoor usage to reduce potential for harmful interference to co-Channel mobile satellite systems. High power radars are allocated as primary users (meaning they have priority) of 5250-5350 MHz and 5650-5850 MHz and these radars could cause interference and/or damage to LE-LAN devices.

**Avertissement:** Le dispositif fonctionnant dans la bande 5150-5250 MHz est réservé uniquement pour une utilisation à l'intérieur afin de réduire les risques de brouillage préjudiciable aux systèmes de satellites mobiles utilisant les mêmes canaux.

Les utilisateurs de radars de haute puissance sont désignés utilisateurs principaux (c.-à-d., qu'ils ont la priorité) pour les bands 5250-5350 MHz et 5650-5850 MHz et que ces radars pourraient causer du brouillage et/ou des dommages aux dispositifs LAN-EL.

## 5.3 Health and Safety Recommendations



### 5.3.1 Warnings for Use of Wireless Devices

Please observe all warning notices with regard to the usage of wireless devices.

### 5.3.2 Potentially Hazardous Atmospheres – Fixed Installations

You are reminded of the need to observe restrictions on the use of radio devices in fuel depots, chemical plants etc. and areas where the air contains chemicals or particles (such as grain, dust, or metal powders).

### 5.3.3 Safety in Hospitals



Wireless devices transmit radio frequency energy and may affect medical electrical equipment. When installed adjacent to other equipment, it is advised to verify that the adjacent equipment is not adversely affected.

### 5.3.4 Pacemakers

Pacemaker manufacturers recommended that a minimum of 15cm (6 inches) be maintained between a handheld wireless device and a pacemaker to avoid potential interference with the pacemaker. These recommendations are consistent with independent research and recommendations by Wireless Technology Research.

Persons with Pacemakers:

- Should ALWAYS keep the device more than 15cm (6 inches) from their pacemaker when turned ON.
- Should not carry the device in a breast pocket.
- Should use the ear furthest from the pacemaker to minimize the potential for interference.
- If you have any reason to suspect that interference is taking place, turn OFF your device.

### 5.3.5 Other Medical Devices

Please consult your physician or the manufacturer of the medical device, to determine if the operation of your wireless product may interfere with the medical device.



## 5.4 RF Exposure Guidelines

### 5.4.1 Safety Information

#### Reducing RF Exposure—Use Properly

Only operate the device in accordance with the instructions supplied.

## 5.5 International

The device complies with internationally recognized standards covering human exposure to electromagnetic fields from radio devices. For information on "International" human exposure to electromagnetic fields refer to the Motorola/Symbol Declaration of Conformity (DoC) at

<http://www.motorola.com/doc>

## 5.6 Europe

### Remote and Standalone Antenna Configurations

To comply with EU RF exposure requirements, antennas that are mounted externally at remote locations or operating near users at stand-alone desktop of similar configurations must operate with a minimum separation distance of 20 cm from all persons.

## 5.7 US and Canada

### Co-located statement

To comply with FCC RF exposure compliance requirement, the antenna used for this transmitter must not be co-located or operating in conjunction with any other transmitter/antenna except those already approved in this filing.

Radiation Exposure Statement:

This equipment complies with IC radiation exposure limits set forth for an uncontrolled environment. This equipment should be installed and operated with minimum distance 20cm between the radiator and your body.

NOTE IMPORTANTE: (Pour l'utilisation de dispositifs mobiles)

Déclaration d'exposition aux radiations:

Cet équipement est conforme aux limites d'exposition aux rayonnements IC établies pour un environnement non contrôlé. Cet équipement doit être installé et utilisé avec un minimum de 20 cm de distance entre la source de rayonnement et votre corps.

### Remote and Standalone Antenna Configurations

To comply with FCC RF exposure requirements, antennas that are mounted externally at remote locations or operating near users at stand-alone desktop of similar configurations must operate with a minimum separation distance of 20 cm from all persons.

To satisfy FCC RF exposure requirements, a mobile transmitting device must operate with a minimum separation distance of 20 cm or more from a person's body.

## 5.8 Power Supply

This device can be powered from a 802.3af compliant power source which is certified by the appropriate agencies.



## 5.9 Radio Frequency Interference Requirements—FCC



**Note:** This equipment has been tested and found to comply with the limits for a Class B digital device, pursuant to Part 15 of the FCC rules. These limits are designed to provide reasonable protection against harmful interference in a residential installation. This equipment generates, uses and can radiate radio

frequency energy and, if not installed and used in accordance with the instructions, may cause harmful interference to radio communications. However there is no guarantee that interference will not occur in a particular installation. If this equipment does cause harmful interference to radio or television reception, which can be determined by turning the equipment off and on, the user is encouraged to try to correct the interference by one or more of the following measures:

- Reorient or relocate the receiving antenna
- Increase the separation between the equipment and receiver
- Connect the equipment into an outlet on a circuit different from that to which the receiver is connected
- Consult the dealer or an experienced radio/TV technician for help

### Radio Transmitters (Part 15)

This device complies with Part 15 of the FCC Rules. Operation is subject to the following two conditions: (1) this device may not cause harmful interference, and (2) this device must accept any interference received, including interference that may cause undesired operation.

For RLAN Devices:

The use of 5 GHz RLAN's, for use in the US, have the following restrictions:

- Notched Band 5.60 – 5.65 GHz

## 5.10 Radio Frequency Interference Requirements – Canada

This Class B digital apparatus complies with Canadian ICES-003.

Cet appareil numérique de la classe B est conforme à la norme NMB-003 du Canada.

### 5.10.1 Radio Transmitters

For RLAN Devices:

The use of 5 GHz RLAN's, for use in Canada, have the following restrictions:

- Restricted Band 5.60 – 5.65 GHz

This device complies with RSS 210 of Industry Canada. Operation is subject to the following two conditions: (1) this device may not cause harmful interference and (2) this device must accept any interference received, including interference that may cause undesired operation.

Ce dispositif est conforme à la norme CNR-210 d'Industrie Canada applicable aux appareils radio exempts de licence. Son fonctionnement est sujet aux deux conditions suivantes: (1) le dispositif ne doit pas produire de brouillage préjudiciable, et (2) ce dispositif doit accepter tout brouillage reçu, y compris un brouillage susceptible de provoquer un fonctionnement indésirable.

Label Marking: The Term "IC:" before the radio certification only signifies that Industry Canada technical specifications were met.

To reduce potential radio interference to other users, the antenna type and its gain should be so chosen that the equivalent isotropically radiated power (EIRP) is not more than that permitted for successful communication.

This device has been designed to operate with the antennas listed in section 13 of Enterprise Wireless LAN Antenna Specification Guide (72E-133063-01). Antennas not included in this list or having a greater gain are strictly prohibited for use with this device. The required antenna impedance is 50 ohms.

## 5.11 CE Marking and European Economic Area (EEA)



The use of 2.4 GHz WLAN's, for use through the EEA, have the following restrictions:

- Maximum radiated transmit power of 100 mW EIRP in the frequency range 2.400 -2.4835 GHz.
- France, outside usage is restricted to 2.4 – 2.454 GHz.
- Italy requires a user license for outside usage.

## 5.12 Statement of Compliance

Motorola/Symbol hereby, declares that this device is in compliance with the essential requirements and other relevant provisions of Directive 1999/5/EC. A Declaration of Conformity may be obtained from <http://www.motorola.com/doc>.

## 5.13 Waste Electrical and Electronic Equipment (WEEE)

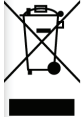

**English:** For EU Customers: All products at the end of their life must be returned to Symbol for recycling. For information on how to return product, please go to: [http://www.symbol.com/environmental\\_compliance](http://www.symbol.com/environmental_compliance).

**Čeština:** Pro zákazníky z EU: Všechny produkty je nutné po skončení jejich životnosti vrátit společnosti Symbol k recyklaci. Informace o způsobu vrácení produktu najdete na webové stránce: [http://www.symbol.com/environmental\\_compliance](http://www.symbol.com/environmental_compliance).

**Dansk:** Til kunder i EU: Alle produkter skal returneres til Symbol til recirkulering, når de er udtjent. Læs oplysningerne om returnering af produkter på: [http://www.symbol.com/environmental\\_compliance](http://www.symbol.com/environmental_compliance).

**Deutsch:** Für Kunden innerhalb der EU: Alle Produkte müssen am Ende ihrer Lebensdauer zum Recycling an Symbol zurückgesandt werden. Informationen zur Rücksendung von Produkten finden Sie unter [http://www.symbol.com/environmental\\_compliance](http://www.symbol.com/environmental_compliance).

**Eesti:** EL klientidele: kõik tooted tuleb nende eluea lõppedes tagastada taaskasutamise eesmärgil Symbol'ile. Lisainformatsiooni saamiseks toote tagastamise kohta külastage palun aadressi: [http://www.symbol.com/environmental\\_compliance](http://www.symbol.com/environmental_compliance).

**Español:** Para clientes en la Unión Europea: todos los productos deberán entregarse a Symbol al final de su ciclo de vida para que sean reciclados. Si desea más información sobre cómo devolver un producto, visite: [http://www.symbol.com/environmental\\_compliance](http://www.symbol.com/environmental_compliance).

**Ελληνικά:** Για πελάτες στην Ε.Ε.: Όλα τα προϊόντα, στο τέλος της διάρκειας ζωής τους, πρέπει να επιστρέφονται στην Symbol για ανακύκλωση. Για περισσότερες πληροφορίες σχετικά με την επιστροφή ενός προϊόντος, επισκεφθείτε τη διεύθυνση [http://www.symbol.com/environmental\\_compliance](http://www.symbol.com/environmental_compliance) στο Διαδίκτυο.

**Français:** Clients de l'Union Européenne : Tous les produits en fin de cycle de vie doivent être retournés à Symbol pour recyclage. Pour de plus amples informations sur le retour de produits, consultez : [http://www.symbol.com/environmental\\_compliance](http://www.symbol.com/environmental_compliance).

**Italiano:** per i clienti dell'UE: tutti i prodotti che sono giunti al termine del rispettivo ciclo di vita devono essere restituiti a Symbol al fine di consentirne il riciclaggio. Per informazioni sulle modalità di restituzione, visitare il seguente sito Web: [http://www.symbol.com/environmental\\_compliance](http://www.symbol.com/environmental_compliance).

**Latviešu:** ES klientiem: visi produkti pēc to kalpošanas mūža beigām ir jānogādā atpakaļ Symbol otrreizējai pārstrādei. Lai iegūtu informāciju par produktu nogādāšanu Symbol, lūdzu, skatiet: [http://www.symbol.com/environmental\\_compliance](http://www.symbol.com/environmental_compliance).

**Lietuvių:** ES vartotojams: visi gaminiai, pasibaigus jų eksploatacijos laikui, turi būti grąžinti utilizuoti į kompaniją „Symbol“. Daugiau informacijos, kaip grąžinti gaminį, rasite: [http://www.symbol.com/environmental\\_compliance](http://www.symbol.com/environmental_compliance).

**Magyar:** Az EU-ban vásárlóknak: Minden tönkrement termékét a Symbol vállalathoz kell eljuttatni újrahasznosítás céljából. A termék visszajuttatásának módjával kapcsolatos tudnivalóért látogasson el a [http://www.symbol.com/environmental\\_compliance](http://www.symbol.com/environmental_compliance) weboldalra

**Malti:** Għal klijenti fl-UE: il-prodotti kollha li jkunu waslu fl-aħħar tal-hajja ta' l-użu tagħhom, iridu jiġu rritornati għand Symbol għar-riċiklaġġ. Għal aktar taġġir dwar kif għandek tirritorna l-prodott, jekk jogħġbok żur: [http://www.symbol.com/environmental\\_compliance](http://www.symbol.com/environmental_compliance).

**Nederlands:** Voor klanten in de EU: alle producten dienen aan het einde van hun levensduur naar Symbol te worden teruggezonden voor recycling. Raadpleeg [http://www.symbol.com/environmental\\_compliance](http://www.symbol.com/environmental_compliance) voor meer informatie over het terugzenden van producten.

**Polski:** Klienci z obszaru Unii Europejskiej: Produkty wycofane z eksploatacji należy zwrócić do firmy Symbol w celu ich utylizacji. Informacje na temat zwrotu produktów znajdują się na stronie internetowej [http://www.symbol.com/environmental\\_compliance](http://www.symbol.com/environmental_compliance).

**Português:** Para clientes da UE: todos os produtos no fim de vida devem ser devolvidos à Symbol para reciclagem. Para obter informações sobre como devolver o produto, visite: [http://www.symbol.com/environmental\\_compliance](http://www.symbol.com/environmental_compliance).

**Slovenski:** Za kupce v EU: vsi izdelki se morajo po poteku življenjske dobe vrniti podjetju Symbol za reciklažo. Za informacije o vračilu izdelka obiščite: [http://www.symbol.com/environmental\\_compliance](http://www.symbol.com/environmental_compliance).

**Slovenščina:** Pre zákazníkov z krajín EU: Všetky výrobky musia byť po uplynutí doby ich životnosti vrátené spoločnosti Symbol na recykláciu. Bližšie informácie o vrátení výrobkov nájdete na: [http://www.symbol.com/environmental\\_compliance](http://www.symbol.com/environmental_compliance).

**Suomi:** Asiakkaat Euroopan unionin alueella: Kaikki tuotteet on palautettava kierrätettäväksi Symbol-yhtiöön, kun tuotetta ei enää käytetä. Lisätietoja tuotteen palauttamisesta on osoitteessa [http://www.symbol.com/environmental\\_compliance](http://www.symbol.com/environmental_compliance).

## 5.14 TURKISH WEEE Statement of Compliance

EEE Yönetmeliğine Uygundur

## 5.15 Japan (VCCI) - Voluntary Control Council for Interference

### Class B ITE

この装置は、情報処理装置等電波障害自主規制協議会（VCCI）の基準に基づくクラスB情報技術装置です。この装置は、家庭環境で使用することを目的としていますが、この装置がラジオやテレビジョン受信機に近接して使用されると、受信障害を引き起こすことがあります。取扱説明書に従って正しい取り扱いをして下さい。

This is a Class B product based on the standard of the Voluntary Control Council for Interference from Information Technology Equipment (VCCI). If this is used near a radio or television receiver in a domestic environment, it may cause radio interference. Install and use the equipment according to the instruction manual.

## 5.16 Korea Warning Statement for Class B ITE

기종별	사용자안내문
B 급 기기 (가정용 방송통신기기)	이 기기는 가정용 (B 급) 으로 전자파적합등록을 한 기기로서 주로 가정에서 사용하는 것을 목적으로 하며, 모든 지역에서 사용할 수 있습니다.
Class B (Broadcasting Communication Device for Home Use)	This device obtained EMC registration mainly for home use (Class B) and may be used in all areas.

## 5.17 Other Countries

### 5.17.1 Australia

Use of 5 GHz WLAN's in Australia is restricted in the following band 5.50 – 5.65 GHz.

### 5.17.2 Brazil

#### Regulatory declarations for AP-650 - BRAZIL

Note: The certification mark applied to the AP-650 is for Restrict Radiation Equipment. This equipment operates on a secondary basis and does not have the right for protection against harmful interference from other users including same equipment types. Also this equipment must not cause interference to systems operating on primary basis.

For more information consult the website <http://www.anatel.gov.br>

#### Declarações Regulamentares para AP-650 - Brasil

**Nota:** "A marca de certificação se aplica ao Transceptor, modelo AP-650. Este equipamento opera em caráter secundário, isto é, não tem direito a proteção contra interferência prejudicial, mesmo de estações do mesmo tipo, e não pode causar interferência a sistemas operando em caráter primário."

Para maiores informações sobre ANATEL consulte o site: <http://www.anatel.gov.br>

### 5.17.3 Chile

"Este equipo cumple con la Resolución No 403 de 2008, de la Subsecretaria de telecomunicaciones, relativa a radiaciones electromagnéticas."

"This device complies with the Resolution Not 403 of 2008, of the Undersecretary of telecommunications, relating to electromagnetic radiation."

### 5.17.4 China

Quality Certificate in Chinese when the factory has ISO 9001 certification.

合格证 : Quality Certificate



### 5.17.5 Mexico

Restrict Frequency Range to: 2.450 – 2.4835 GHz.

### 5.17.6 South Korea

For a radio equipment using 2400~2483.5MHz or 5725~5825MHz, the following two expression should be displayed:”

당해 무선설비는 운용 중 전파혼신 가능성이 있음

당해 무선설비는 전파혼신 가능성이 있으므로 인명안전과 관련된 서비스는 할 수 없습니다

## 5.17.7 Taiwan

### 臺灣

#### 低功率電波輻射性電機管理辦法

##### 第十二條

經型式認證合格之低功率射頻電機，非經許可，公司、商號或使用者均不得擅自變更頻率、加大功率或變更原設計之特性及功能。

##### 第十四條

低功率射頻電機之使用不得影響飛航安全及干擾合法通信；經發現有干擾現象時，應立即停用，且改善至無干擾時方得繼續使用。

前項合法通信，指依電信規定作業之無線電通信。

低功率射頻電機須忍受合法通信或工業、科學及醫療用電波輻射性電機設備之干擾。

在 5.25-5.35 赫頻帶內操作之無線資訊傳輸設備，限於室內使用。

## 6 Motorola Solutions Enterprise Mobility Support Center

If you have a problem with your equipment, contact Enterprise Mobility support for your region. Support and issue resolution is provided for products under warranty or that are covered by an Enterprise Mobility Services agreement. Contact information and web self-service is available by visiting <http://supportcentral.motorola.com/>

When contacting Enterprise Mobility support, please provide the following information:

- Serial number of the unit
- Model number or product name
- Software type and version number

Motorola Solutions responds to calls by email or telephone within the time limits set forth in support agreements. If you purchased your Enterprise Mobility business product from a Motorola business partner, contact that business partner for support.

### 6.1 Customer Support Web Sites

Motorola's Support Central Web site, located at <http://supportcentral.motorola.com/> provides information and online assistance including developer tools, software downloads, product manuals, support contact information and online repair requests.

### 6.2 Manuals

<http://support.symbol.com/support/product/manuals.do>



## 7 AP6532 Series ROHS Compliance

部件名称 (Parts)	有毒有害物质或元素 					
	铅 (Pb)	汞 (Hg)	镉 (Cd)	六价铬 (Cr <sup>6+</sup> )	多溴联 苯 (PBB)	多溴二苯 醚 (PBDE)
金属部件 (Metal Parts)	X	○	○	○	○	○
电路模块 (Circuit Modules)	X	○	○	○	○	○
电缆及电缆组件 (Cables and Cable Assemblies)	○	○	○	○	○	○
塑料和聚合物部件 (Plastic and Polymeric Parts)	○	○	○	○	○	○
光学和光学组件 (Optics and Optical Components)	○	○	○	○	○	○
电池 (Batteries)	○	○	○	○	○	○

○：表示该有毒有害物质在该部件所有均质材料中的含量均在 SJ/T11363-2006 标准规定的限量要求以下。

X：表示该有毒有害物质至少在该部件的某一均质材料中的含量超出 SJ/T11363-2006 标准规定的限量要求。

对销售之日的所售产品，本表表示，公司供应链的电子信息产品可能包含这些物质。注意：在所售产品中可能会也可能不会含有所有所列的部件。

This table was created to comply with China RoHS requirements for Motorola Solutions AP6532 model Access Points.

**MOTOROLA SOLUTIONS**  
**1303 E. ALGONQUIN ROAD**  
**SCHAUMBURG, IL 60196**  
**<http://www.motorolasolutions.com>**

**72E-149368-01 Revision B**  
**October 2011**