

AP-6562 ACCESS POINT INSTALLATION GUIDE



Zebra and the Zebra head graphic are registered trademarks of ZIH Corp. The Symbol logo is a registered trademark of Symbol Technologies, Inc., a Zebra Technologies company.

© 2015 Symbol Technologies, Inc.

1.0 Introduction	5
1.1 Document Conventions	5
1.2 Warnings	6
1.3 Site Preparation	6
1.4 AP-6562 Package Contents	6
1.4.1 Internal Antenna Model Package Contents	6
1.4.2 External Antenna Model Package Contents	7
1.4.3 Features	7
2.0 Hardware Installation	8
2.1 Installation Instructions	8
2.2 Access Point Placement	8
2.3 AP-6562 Hardware Mounting and Installation	9
2.3.1 Mounting Bracket Kit	9
2.3.2 Extension Arm Kit	10
2.3.3 Pole Mounted Installations	11
2.3.4 Vertical Pole Mount	12
2.3.5 Wall Mounted Installation	15
2.4 AP-6562 Internal Antenna Model Antenna Options	17
2.5 AP-6562 External Antenna Model Antenna Options	18
2.6 AP-6562 LED Indicators	20
3.0 Basic Access Point Configuration	22
4.0 Specifications	33
4.1 AP-6562 Internal Antenna Model Electrical Specifications	33
4.2 AP-6562 Internal Antenna Model Physical Specifications	33
4.3 AP-6562 Internal Antenna Model Antenna Specifications	33
4.4 AP-6562 External Antenna Model Electrical Specifications	34
4.5 AP-6562 External Antenna Model Physical Specifications	34
4.6 Radio Specifications	35

5.0 Regulatory Information	36
5.1 Regulatory Information	36
5.2 Wireless Device Country Approvals	36
5.2.1 Country Selection	36
5.2.2 Frequency of Operation - FCC and IC	37
5.3 Health and Safety Recommendations	37
5.3.1 Warnings for Wireless Devices	37
5.3.2 Potentially Hazardous Atmospheres - Fixed Installations	37
5.3.3 Safety in Hospitals	38
5.4 RF Exposure Guidelines	38
5.5 International	38
5.6 Europe	38
5.7 US and Canada	39
5.8 Power Supply	39
5.9 Radio Frequency Interference Requirements - FCC	39
5.10 Radio Frequency Interference Requirements - Canada	40
5.11 CE Marking ad European Economic Area (EEA)	41
5.12 Statement of Compliance	41
5.13 Other Countries	41
5.13 Waste Electrical and Electronic Waste Equipment (WEEE)	43
5.14 Turkish WEEE Statement of Compliance	44
6.0 Support	45
7.0 AP-6562 Access Point China ROHS Compliance	46

1 Introduction

The AP-6562 access point links wireless 802.11abgn devices, enabling the growth of your wireless network with a cost effective alternative to standard access points. The AP-6562 access point provides multiple deployment options.

The AP-6562 access point receives all power and transfers data through the same CAT-5 or better Ethernet cable. An 802.3at Ethernet switch or power supply (specifically rated for the AP-6562) is required, such as the AP-PSBIAS-7161-US or AP-PSBIAS-7161-WW outdoor rated power supply

An AP-6562 model access point uses WiNG 5 software as its onboard operating system. The access point's unique WiNG 5 software enables the access point to function as either a Virtual Controller AP capable of adopting and managing up to 24 additional AP-6562 access points or a Standalone access point managed by its connected controller.

If new to access point technology, refer to the *WiNG Access Point System Reference Guide* to familiarize yourself with access point technology and the feature set supported by the WiNG operating system. The guide is available at www.zebra.com/support.

The AP-6562 access point is approved under MODEL: AP-6562.

This document is written for the qualified network device installer.

1.1 Document Conventions

The following graphical alerts are used in this document to indicate notable situations:



NOTE Tips, hints, or special requirements that you should take note of.



CAUTION Care is required. Disregarding a caution can result in data loss or equipment malfunction.



WARNING! Indicates a condition or procedure that could result in personal injury or equipment damage.

1.2 Warnings

- Read all installation instructions and site survey reports, and verify correct equipment installation before connecting the Access Point.
- Remove jewelry and watches before installing this equipment.
- Verify the unit is grounded before connecting it to the power source.
- Verify any device connected to this unit is properly wired and grounded.
- Verify there is adequate ventilation around the device, and that ambient temperatures meet equipment operation specifications.

1.3 Site Preparation

- Consult your site survey and network analysis reports to determine specific equipment placement, power drops, and so on.
- Assign installation responsibility to the appropriate personnel.
- Identify and document where all installed components are located.
- Ensure adequate, dust-free ventilation to all installed equipment.
- Identify and prepare Ethernet and console port connections.
- Verify cable lengths are within the maximum allowable distances for optimal signal transmission.

1.4 AP-6562 Package Contents

An AP-6562 access point is available in internal antenna and external antenna models. Contents differ depending on the model ordered.

1.4.1 Internal Antenna Model Package Contents

Part Number	Description
AP-6562-66030-US	AP-6562: Outdoor Dual Radio 802.11N US
AP-6562-66030-WR	AP-6562 Outdoor Dual Radio 802.11N INTL
AP-6562-66030-EU	AP-6562 Outdoor Dual Radio 802.11N EU

AP-6562 internal antenna models (AP-6562-66030-US, AP-6562-66030-WW and AP-6562-66030-EU) include the following:

- Access Point with internal antennas
- Weatherproof RJ45 plug kit
- AP-6562 Installation Guide (*This Guide*)

1.4.2 External Antenna Model Package Contents

Part Number	Description
AP-6562-66040-US	AP-6562 Outdoor Dual Radio 802.11N US
AP-6562-66040-WR	AP-6562 Outdoor Dual Radio 802.11N INTL
AP-6562-66040-EU	AP-6562 Outdoor Dual Radio 802.11N EU

AP-6562 external antenna models (AP-6562-66040-US, AP-6562-66040-WR and AP-6562-66040-EU) include the following:

- Access Point with external antenna connectors
- Weatherproof RJ45 plug kit
- AP-6562 Installation Guide (*This Guide*)

1.4.3 Features

- GE1/PoE LAN port
- Console port
- LED indicators (see [AP-6562 LED Indicators on page 20](#))

The illustration below is of an internal antenna model.



NOTE When operating in a Gigabit Ethernet environment, CAT-5e or CAT-6 cable is recommended for Gigabit operation.

The Access Point comes with dual radios supporting 802.11abgn. The access point contains runtime firmware which enables the unit to boot after a power up. The runtime firmware on the access point and the firmware downloaded from the connected controller can be updated via the Ethernet interface.

2 Hardware Installation

2.1 Installation Instructions

To prepare for the installation:

1. Match the model number on the purchase order with the model numbers in the packing list and on the case of the access point.
2. Verify the contents of the box include the intended AP-6562 access point, and the included hardware matches the package contents for an internal antenna access point (see [Internal Antenna Model Package Contents on page 6](#)) or external antenna access point (see [External Antenna Model Package Contents on page 7](#)).
3. Review site survey and network analysis reports to determine the location and mounting position for the AP-6562 access point.
4. Connect a CAT-5 or better Ethernet cable to a compatible 802.3at power source and run the cable to the installation site. Ensure there is sufficient slack on the cable to perform the installation steps.



NOTE When operating in a Gigabit Ethernet environment, CAT-5e or CAT-6 cable is recommended for Gigabit operation.

2.2 Access Point Placement

For optimal performance, install the access point away from transformers, heavy-duty motors, fluorescent lights, microwave ovens, refrigerators and other industrial equipment. Signal loss can occur when metal, concrete, walls or floors block transmission. Install the access point in an open area or add access points as needed to improve coverage.

Place the access point using the following guidelines:

- Orient the access point antennas vertically for best reception (applies to external antenna models only).
- When deploying outdoor mesh networks using a pole mounted installation, install the access point at an ideal height of 30 to 35 feet from the ground.

To maximize the access point's radio coverage area, conduct a site survey to define and document radio interference obstacles before installing the access point.

2.3 AP-6562 Hardware Mounting and Installation

It is recommended to use the AP-6562 mounting bracket kit (KT-147407-01) for most deployments. When a standoff distance is required for a pole mounted or wall mounted installation, use the extension arm kit (KT-150173-01).

2.3.1 Mounting Bracket Kit

The AP-6562 mounting bracket kit (KT-147407-01) includes the access point bracket (left), angle adapter bracket (center), and pole mount bracket (right) sections:

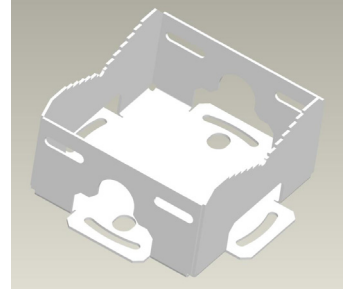
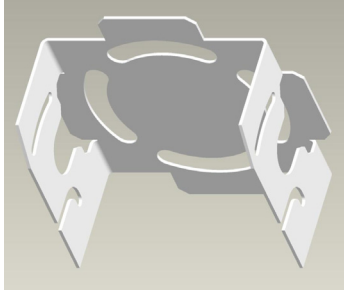
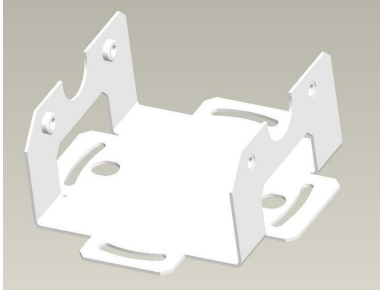

The access point bracket and the angle adapter bracket can rotated (plus or minus 15 degrees) and tilted (up to 45 degrees) to achieve the required angle and rotation.

The following ancillary hardware to assemble the mounting bracket sections is included in the kit::

Description	Quantity
M6 serrated hex flanged screws	8
1/2 inch hex head nut	2
1/2 inch x 3/4 inch hex head bolt	2

A torque wrench or ratchet with a 10mm adapter, or an adjustable wrench, can be used to assemble the mounting brackets. A finished assembly of the mounting bracket kit is shown below. Assembly during deployment may differ to achieve the required angle and rotation.



2.3.2 Extension Arm Kit

When mounting an AP-6562 on poles more than 3 inches in diameter, use the extension arm kit (KT-150173-01) to provide a minimum standoff distance of twelve inches to avoid interference with the antennas. The extension arm kit is only required for AP-6562 external antenna models.

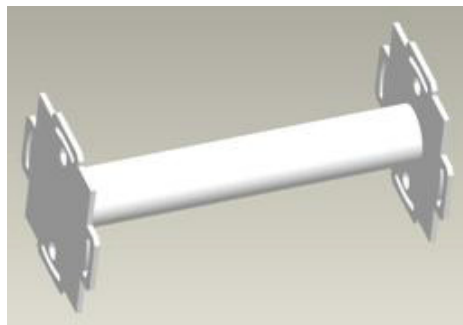

The extension arm kit can also be used in combination with the any of the brackets from the mounting bracket kit.

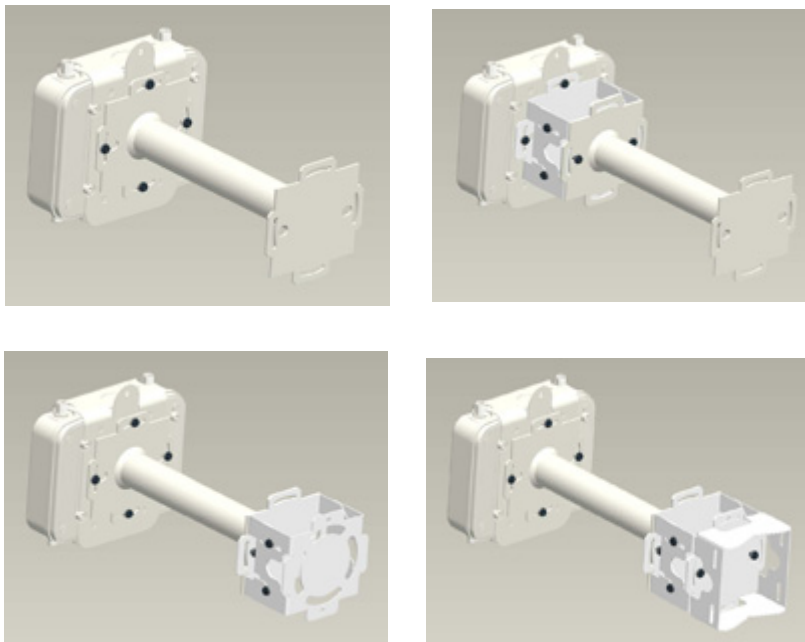

The following ancillary hardware to attach the extension arm to the mounting bracket kit sections is included in the extension arm kit:

Description	Quantity
1/2 inch hex head nut	2
1/2 inch x 3/4 inch hex head bolt	2

2.3.3 Pole Mounted Installations

The mounting hardware kit and extension arm can be used in various combinations to properly install the AP-6562 on a pole. For poles of up to 3 inches in diameter, attach the pole mount bracket of the mounting hardware kit at the desired position on the pole using band clamps up to 3/4 inch width, or a 1/2 inch x 4 inch wide U-bolt and nuts. For poles greater than 3 inches in diameter, attach the pole mount bracket using band clamps.



NOTE The U-bolt and band clamps are not included in the mounting bracket kit.



NOTE The extension arm is recommended for installations on poles greater than 3 inches in diameter.

2.3.4 Vertical Pole Mount

Use the following procedures for vertical pole mount installations. The extension arm is recommended when mounting the access point to poles greater than 3 inches in diameter.

For poles up to 3 inches in diameter when using a U-bolt

1. Thread the two inner nuts onto the U-bolt. Place the U-bolt at the desired mounting location.
2. Place the pole mount bracket section on the U bolt. Adjust the inner nuts until the pole mount bracket section is against the pole and the U-bolt can be secured tightly to the pole.
3. Place the angle adapter bracket section on the U-bolt with the open slot connections on the bottom and align it with the pole mount section.
4. Put the two outer nuts on the U-bolt to attach the angle adapter bracket section to the pole mount bracket section.
5. Tighten all nuts to 300 inch pounds (lbf-in).
6. Position the access point bracket section so that the bottom of the section with the straight (not bevel cut) side is oriented toward the bottom side of the access point. Using a torque wrench or a ratchet and a 10mm socket, or an adjustable wrench, attach (but don't tighten) the access point bracket section to the AP-6562 with the with four M6 hex flange screws.
7. Insert two M6 hex flange screws into the bottom holes on the sides of the access point bracket section.
8. Insert the two M6 hex flange screws in the bottom holes on the sides of the access point bracket section into the open slot connections on the bottom of the angle adapter bracket section.
9. Rotate the access point bracket section upward and align the top holes on the sides with the top holes on the angle adapter bracket section. Insert two M6 hex flange screws into the top holes on the angle adapter bracket section.
10. Use a torque wrench or a ratchet and a 10mm socket, or an adjustable wrench, to finish attaching the access point bracket section to the angle adapter bracket section with the M6 hex flange screws in the open slot connections and the top holes on the angle adapter bracket section. Do not tighten the screws until all rotation and tilt adjustments are complete.
11. To adjust the position of the access point, rotate the access point bracket section (plus or minus 15 degrees) and tilt the angle adapter bracket section (up to 45 degrees).
12. Tighten all hex flange screws to 60 inch pounds (lbf-in).
13. If required, install and attach a Kensington security cable (customer supplied) to the unit's lock port.
14. Attach an Ethernet cable from the access point to a controller with an 802.3at-compatible power source or use the designated outdoor rated power supply (AP-PSBIAS-7161-US or AP-PSBIAS-7161-WW) to supply power to the AP-6562 (once fully cabled).

15. Verify the unit has power by observing that the LEDs are lit or flashing.



CAUTION If not using a 802.3at capable controller to power the AP-6562, ensure only the AP-6562's designated outdoor power supply (AP-PSBIAS-7161-US or AP-PSBIAS-7161-WW) is used to supply power to the access point. Using an incorrectly rated power supply could damage the unit and void the product warranty. Do not actually connect to the power source until the cabling portion of the installation is complete.

For mounting with band clamps:

1. Attach the pole mount bracket section at the desired mounting location using band clamps.
2. With the angle adapter bracket section positioned so that the open connector slots are on the bottom, attach the angle adapter bracket section to the pole mount bracket section using two 1/2 inch bolts and nuts. Tighten the nuts to 30 inch pounds (lbf-in).
3. Position the access point bracket section so that the bottom of the section with the straight (not bevel cut) sides is oriented toward the bottom side of the access point. Using a torque wrench or a ratchet and a 10mm socket, or an adjustable wrench, attach (but don't tighten) the access point bracket section to the AP-6562 with the with four M6 hex flange screws.
4. Insert two M6 hex flange screws into the bottom holes on the sides of the access point bracket section.
5. Insert the two M6 hex flange screws in the bottom holes on the sides of the access point bracket section into the open slot connections on the bottom of the angle adapter bracket section.
6. Rotate the access point bracket section upward and align the top holes on the sides with the top holes on the angle adapter bracket section. Insert two M6 hex flange screws into the top holes on the angle adapter bracket section.
7. Use a torque wrench or a ratchet and a 10mm socket, or an adjustable wrench, to finish attaching the access point bracket section to the angle adapter bracket section with the M6 hex flange screws in the open slot connections and the top holes on the angle adapter bracket section. Do not tighten the screws until all rotation and tilt adjustments are complete.
8. Tighten all hex flange screws to 60 inch pounds (lbf-in).
9. If required, install and attach a Kensington security cable (customer supplied) to the unit's lock port.
10. Attach an Ethernet cable from the access point to a controller with an 802.3at-compatible power source or use the designated outdoor rated power supply (AP-PSBIAS-7161-US or AP-PSBIAS-7161-WW) to supply power to the AP-6562 (once fully cabled).

11. Verify the unit has power by observing that the LEDs are lit or flashing.



CAUTION If not using a 802.3at capable controller to power the AP-6562, ensure only the AP-6562's designated outdoor power supply (AP-PSBIAS-7161-US or AP-PSBIAS-7161-WW) is used to supply power to the access point. Using an incorrectly rated power supply could damage the unit and void the product warranty. Do not actually connect to the power source until the cabling portion of the installation is complete.

To use the extension arm with the mounting hardware kit:

1. Attach the pole mount section at the desired mounting location using a U-bolt or band clamps.
2. Complete the steps for assembling and positioning the mounting bracket sections for poles less than or greater than 3 inches (see [Vertical Pole Mount on page 12](#)).
3. Using a torque wrench or a ratchet and a 10mm socket, or an adjustable wrench, attach the extension arm to the access point bracket section with four M6 hex flange screws. Tighten the hex flange screws to 60 inch pounds (lbf-in).
4. With the access point properly positioned, attach the extension arm to the access point with four M6 hex flange screws. Tighten the hex flange screws to 60 inch pounds (lbf-in).
5. If required, install and attach a Kensington security cable (customer supplied) to the unit's lock port.
6. Attach an Ethernet cable from the access point to a controller with an 802.3at-compatible power source or use the designated outdoor rated power supply (AP-PSBIAS-7161-US or AP-PSBIAS-7161-WW) to supply power to the AP-6562 (once fully cabled).
7. Verify the unit has power by observing that the LEDs are lit or flashing.



CAUTION If not using a 802.3at capable controller to power the AP-6562, ensure only the AP-6562's designated outdoor power supply (AP-PSBIAS-7161-US or AP-PSBIAS-7161-WW) is used to supply power to the access point. Using an incorrectly rated power supply could damage the unit and void the product warranty. Do not actually connect to the power source until the cabling portion of the installation is complete.

2.3.5 Wall Mounted Installation

For wall mounted installations, use only the access point bracket and if required the angle adapter bracket. The access point can also be installed using the sheet metal tab on the top of the enclosure.



NOTE The U-bolt and band clamps are not included in the mounting bracket kit.



NOTE The lag bolts are not included in the mounting bracket kit.

1. With the open slot connections facing down, attach the angle adapter bracket section at the desired mounting location using four #10/32 lag bolts.
2. Using a torque wrench or a ratchet and a 10mm socket, or an adjustable wrench, attach (but don't tighten) the access point bracket section to the AP-6562 with four M6 hex flange screws and insert two M6 hex flange screws into the bottom holes on the sides of the access point bracket section.
3. Insert the two M6 hex flange screws in the bottom holes on the sides of the access point bracket section into the open slot connections on the bottom of the angle adapter bracket section.
4. Rotate the access point bracket section upward and align the top holes on the sides with the top holes on the angle adapter bracket section. Insert two M6 hex flange screws into the top holes on the angle adapter bracket section.
5. Use a torque wrench or a ratchet and a 10mm socket, or an adjustable wrench, to finish attaching the angle adapter bracket section to the access point bracket section with the four M6 hex flange screws in the open slot connections and the top holes on the angle adapter bracket section. Do not tighten the screws until all rotation and tilt adjustments are complete.
6. To adjust the position of the access point, rotate the access point bracket section (plus or minus 15 degrees) and tilt the angle adapter bracket section (up to 45 degrees).
7. Tighten all hex flange screws to 60 inch pounds (lbf-in).
8. If required, install and attach a Kensington security cable (customer supplied) to the unit's lock port.
9. Attach an Ethernet cable from the access point to a controller with an 802.3at-compatible power source or use the designated outdoor rated power supply (AP-PSBIAS-7161-US or AP-PSBIAS-7161-WW) to supply power to the AP-6562 (once fully cabled).
10. Verify the unit has power by observing that the LEDs are lit or flashing.



CAUTION If not using a 802.3at capable controller to power the AP-6562, ensure only the AP-6562's designated outdoor power supply (AP-PSBIAS-7161-US or AP-PSBIAS-7161-WW) is used to supply power to the access point. Using an incorrectly rated power supply could damage the unit and void the product warranty. Do not actually connect to the power source until the cabling portion of the installation is complete.

To use only the extension arm:

1. Using four #10/32 lag bolts, attach the extension arm at the desired mounting location.
2. Using a torque wrench or a ratchet and a 10mm socket, or an adjustable wrench, attach the mounting extension arm to the access point with four M6 hex flange screws. Tighten the hex flange screws to 60 inch pounds (lbf-in).

To use the extension arm with the mounting hardware kit:

1. With the open slot connections facing down, attach the angle adapter bracket section at the desired mounting location using four #10/32 lag bolts.
2. Complete the steps for assembling and positioning the angle adapter bracket and access point bracket sections as outlined above (see [Vertical Pole Mount on page 12](#)).
3. Attach the extension arm to the access point bracket section of the assembled mounting bracket already in position using four M6 hex flange screws. Tighten the hex flange screws to 60 inch pounds (lbf-in).
4. Using a torque wrench or a ratchet and a 10mm socket, or an adjustable wrench, attach the extension arm to the access point with four M6 hex flange screws. Tighten the hex flange screws to 60 inch pounds (lbf-in).

2.4 AP-6562 Internal Antenna Model

AP-6562 internal antenna models (AP-6562-66030-US, AP-6562-66030-WR and AP-6562-66030-EU) are configured with four internal antennas.



2.5 AP-6562 External Antenna Model

AP-6562 external antenna models (AP-6562-66040-US, AP-6562-66040-WR and AP-6562-66040-EU) are configured with four external N type connectors.





NOTE If an antenna connector is unused, the open connector must be covered with an appropriate threaded metal or plastic antenna connector cover.

The labels for Radio 1-0, Radio 1-1, Radio 2-0 and Radio 2-1 are molded into the AP-6562 access point enclosure beside the antenna connectors. When mounting antennas to the connectors, ensure that you have selected the appropriate band for the configured radio. Radio 1 is a 2.4 GHz radio.

Three antenna suites are available to support 2.4 GHz band, 5 GHz band, and dual band options. Select an antenna model best suited to the intended operational environment of your access point.

The 2.4 GHz antenna suite includes the following models:

Part Number	Antenna Type	Maximum Gain
ML-2499-HPA8-01	Outdoor rated dipole antenna; N-Male Connector	8
ML-2499-HPA4-01	Outdoor rated dipole antenna; N-Male Connector	4
ML-2499-HPA3-01R	Outdoor rated dipole antenna; RP-BNC Male Connector	8

The 5 GHz antenna suite includes the following models:

Part Number	Antenna Type	Maximum Gain
ML-5299-HPA5-01	Outdoor rated dipole antenna; N-Male Connector	5
ML-5299-FHPA6-01	Outdoor rated dipole antenna; N-Male Connector	8

The dual band antenna suite includes the following model:

Part Number	Antenna Type	Maximum Gain
ML-2452-HPAG5A8-01	Outdoor rated dipole antenna; N-Male Connector	5



NOTE Dual band antennas should only be used on Radio 2-0 and Radio 2-1 connectors.

For up-to-date information on supported antennas and antenna specifications, please refer to the *Enterprise Wireless LAN Antenna Specification Guide*. For more information, refer to www.zebra.com/support.

2.6 AP-6562 LED Indicators

Both internal antenna and external antenna models have LED activity indicators on the front of the case.



The LEDs provide a status display indicating error conditions, transmission, and network activity for the 5 GHz 802.11an (amber) radio or the 2.4 GHz 802.11bgn (green) radio.

Task	5 GHz Activity LED (Amber)	2.4 GHz Activity LED (Green)
Unadopted	Off	Blink interval at 5 times a second
Normal Operation	<ul style="list-style-type: none"> • If this radio band is enabled: Blink at 5 second interval • If this radio band is disabled: Off • If there is activity on this band: Blink interval at 1 time per second 	<ul style="list-style-type: none"> • If this radio band is enabled: Blink at 5 second interval • If this radio band is disabled: Off • If there is activity on this band: Blink interval at 1 time per second
Firmware Update	On	Off
Sensor Mode	Blink interval at 5 times a second	Blink interval at 5 times a second

3 Basic Access Point Configuration

Once the Access Point is installed and powered on, complete the following steps to get the device up and running and access management functions:

1. Attach an Ethernet cable from the Access Point to a controller with an 802.3af compatible power source or use the designated outdoor rated power supply (AP-PSBIAS-7161-US or AP-PSBIAS-7161-WW) to supply power to the AP-6562 (once fully cabled).

If your host system is a DHCP server, an IP address is automatically assigned to the Access Point and can be used for device connection. However, if a DHCP server is not available, you'll need to derive the IP address from the Access Point MAC address. Using this method, the last two bytes of the MAC address become the last two octets of the IP address. For example:

MAC address - 00:C0:23:00:F0:0A

Zero-Config IP address - 169.254.240.10

To derive the Access Point's IP address using its MAC address:

- a. Open the Windows calculator by selecting *Start > All Programs > Accessories > Calculator*. This menu path may vary slightly depending on your version of Windows.
 - b. With the Calculator displayed, select *View > Scientific*. Select the **Hex** radio button.
 - c. Enter a hex byte of the Access Point's MAC address. For example, F0.
 - d. Select the **Dec** radio button. The calculator converts F0 into 240. Repeat this process for the last Access Point MAC address octet.
2. Point the Web browser to the Access Point's IP address. The following login screen displays:



The screenshot shows a login interface with a blue background. It contains three input fields: 'Username', 'Password', and 'Language'. The 'Language' field is a dropdown menu currently set to 'English'. Below the fields are two buttons: 'Login' and 'Reset'.

3. Enter the default username *admin* in the **Username** field.
4. Enter the default password *admin123* in the **Password** field.

5. Click the **Login** button to load the management interface.



NOTE When logging in for the first time, you're prompted to change the password to enhance device security in subsequent logins.



NOTE If you get disconnected when running the wizard, you can connect again with the Access Point's actual IP address (once obtained) and resume the wizard.

6. If this is the first time the management interface has been accessed, the Initial Setup Wizard automatically displays.



Function Highlight

- Access Point Types: Virtual Controller AP, Standalone AP, or Dependent AP
- Networking Mode: Bridge or Router Operation
- LAN Configuration
- Radio Configuration
- WAN Configuration
- Wireless LAN Setup
- Location, Country Code, Time Zone, Date and Time
- Summary and Save/Commit

Choose One Type to Setup the Access Point

- Typical Setup (Recommended)
 - The wizard uses as many default parameters as possible to simplify the configuration process.
- Advanced Setup
 - With this selection, you may configure the access point's LAN, WAN, Radio Mapping, Radius Server, WLAN, etc.



NOTE The Initial Setup Wizard displays the same content for each Access Point model supported. The only difference being the number of radios configurable by model.

The Introduction screen displays the various actions that can be performed using the wizard under the **Function Highlight** field.

Use the **Choose One type to Setup the Access Point** field options to select the type of wizard to run. The **Typical Setup** is the recommended wizard. This wizard uses the default parameters for most of the configuration parameters and sets up a working network with the least amount of manual configuration.

The **Advanced Setup** wizard is for administrators who prefer more control over the different configuration parameters. A few more configuration screens are available for customization when the Advanced Setup wizard is used.

The first page of the *Initial Setup Wizard* displays the **Navigation Panel** and **Function Highlights** for the configuration activities comprising the Access Point's initial setup. This page also displays options to select the typical or advanced mode for the wizard.

The Navigation Panel for the Typical Setup Wizard displays the basic configuration options.



A green checkmark to the left of an item in the **Navigation Panel** defines the task as having its minimum required configuration set correctly. A red X defines a task as still requiring at least one parameter be defined correctly.

7. Select **Save/Commit** within each page to save the updates made to that page's configuration. Select **Next** to proceed to the next page listed in the Navigation Panel without saving your updates.



NOTE While you can navigate to any page in the navigation panel, you cannot complete the Initial AP Setup Wizard until each task in the Navigation Panel has a green checkmark.

For the purposes of this guide, use the **Typical Setup (Recommended)** option to simplify the process of getting the Access Point up and running quickly with a minimum number of changes to the Access Point's default configuration.

For information on using the Access Point's Advanced Setup option, refer to the *WiNG Access Point System Reference Guide* to familiarize yourself with the feature set supported by the WiNG operating system. The guide is available at www.zebra.com/support.

To configure the Access Point using the Typical Setup Wizard:

8. Select **Typical Setup** from the **Choose One type to Setup the Access Point** field on the Initial Setup Wizard.
9. The Typical Setup Wizard displays the **Access Point Settings** screen to define the Access Point's Standalone versus Virtual Controller AP functionality. This screen also enables selection of the country of operation for the Access Point.



Access Point Type Selection

- Virtual Controller AP - When more than one access point is deployed, a single access point can function as a Virtual Controller AP and manage Dependent mode access points. The Virtual Controller AP can adopt and configure other like APs in a 24-cell deployment.
- Standalone AP - Select this option to deploy this access point as an autonomous "fat" access point. A standalone AP isn't managed by a Virtual Controller AP, or adopted by a controller.

Country

10. Select an **Access Point Type** from the following options:
 - *Virtual Controller AP* - When more than one Access Point is deployed, a single Access Point can function as a Virtual Controller AP. Up to 24 Access Points can be connected to, and managed by, a single Virtual Controller AP of the same Access Point model. These connected Access Points must be the same model as the Virtual Controller AP.

- *Standalone AP* - Select this option to deploy this Access Point as an autonomous fat Access Point. A Standalone AP isn't managed by a Virtual Controller AP, or adopted by a controller.



NOTE If wanting to adopt the Access Point to a controller or service platform, use the controller or service platform's resident UI to connect to the Access Point, provision its configuration and administrate the Access Point's configuration.



NOTE If designating the Access Point as a Standalone AP, use the Access Point's UI to define its device configuration, and not the CLI. The CLI provides the ability to define more than one profile and the UI does not. Consequently, the two interfaces cannot be used collectively to manage profiles without an administrator encountering problems.

11. Select the **Country Code** of the country where the Access Point is deployed. Selecting a proper country is a critical task while configuring the Access Point, as it defines the correct channels of operation and ensures compliance to the regulations of the selected country. This field is only available for the Typical Setup Wizard.
12. Select **Next** to set the Access Point's network mode.

13. The Typical Setup Wizard displays the **Network Topology** screen to define how the Access Point handles network traffic.

Network Topology

- Router Mode - the access point routes traffic between the wireless network and the Internet or corporate network (WAN).

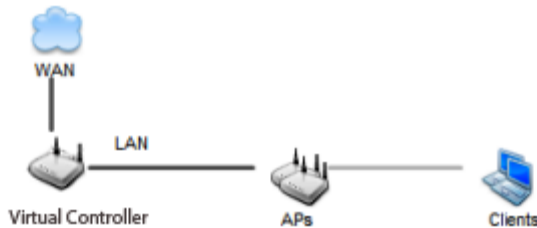

- Bridge Mode - In Bridge Mode, the access point depends on an external router for routing LAN and WAN traffic. Routing is generally used on one device, whereas bridging is typically used in a larger density network. Thus, select Bridge Mode when deploying this access point with numerous peer APs supporting clients on both the 2.4 and 5GHz radio bands.

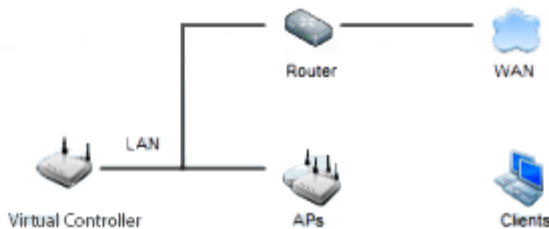

14. Select an Access Point Mode from the available options.

- *Router Mode* - In Router Mode, the Access Point routes traffic between the local network (LAN) and the Internet or external network (WAN). Router mode is recommended in a deployment supported by just a single Access Point.
- *Bridge Mode* - In Bridge Mode, the Access Point depends on an external router for routing LAN and WAN traffic. Routing is generally used on one device, whereas bridging is typically used in a larger density network. Select Bridge Mode when deploying this Access Point with numerous peer Access Points supporting clients on both the 2.4GHz and 5GHz radio bands.



NOTE When Bridge Mode is selected, WAN configuration cannot be performed and the Typical Setup Wizard does not display the WAN configuration screen.

15. Select **Next**. The Typical Setup Wizard displays the **LAN Configuration** screen to set the Access Point's LAN interface configuration.

LAN Configuration

Please configure interface settings for LAN (VLAN 1) which will be used by wireless clients

Use DHCP [What is this?](#)

Static IP Address/Subnet [What is this?](#) *

DHCP Server

Use on-board DHCP server to assign IP addresses to wireless clients

Range --

Default Gateway

Domain Name Server (DNS)

DNS Forwarding

Primary DNS . .

Secondary DNS . . .

16. Set the following DHCP and Static IP Address/Subnet information for the LAN interface:
- *Use DHCP* - Select the checkbox to enable an automatic network address configuration using the Access Point's DHCP server.
 - *Static IP Address/Subnet* - Enter an IP Address and a subnet for the Access Point's LAN interface. If *Use DHCP* is selected, this field is not available. When selecting this option, define the following *DHCP Server* and *Domain Name Server (DNS)* resources, as those fields will become enabled on the bottom portion of the screen.
 - *Use on-board DHCP server to assign IP addresses to wireless clients* - Select the checkbox to enable the Access Point's DHCP server to provide IP and DNS information to clients on the LAN interface.
 - *Range* - Enter a starting and ending IP Address range for client assignments on the LAN interface. Avoid assigning IP addresses from x.x.x.1 - x.x.x.10 and x.x.x.255, as they are often reserved for standard network services. This is a required parameter.
 - *Default Gateway* - Define a default gateway address for use with the default gateway. This is a required parameter.

- *DNS Forwarding* - Select this option to allow a DNS server to translate domain names into IP addresses. If this option is not selected, a primary and secondary DNS resource must be specified. DNS forwarding is useful when a request for a domain name is made but the DNS server, responsible for converting the name into its corresponding IP address, cannot locate the matching IP address.
 - *Primary DNS* - Enter an IP Address for the main Domain Name Server providing DNS services for the Access Point's LAN interface.
 - *Secondary DNS* - Enter an IP Address for the backup Domain Name Server providing DNS services for the Access Point's LAN interface.
17. Select **Next**. The Typical Setup Wizard displays the **Wireless LAN Setup** screen to set the Access Point's Wireless LAN interface configuration.

WLAN 1
WLAN 2



WLAN 1 Configuration

SSID [What is this?](#) *

WLAN Type No Authentication and No Encryption [What is this?](#)

Captive Portal Authentication and No Encryption [What is this?](#)

PSK authentication, WPA2 encryption [What is this?](#)

18. Set the following WLAN1 Configuration parameters:
- *SSID* - Configure the SSID for the WLAN.
 - *WLAN Type* - Configure the encryption and authentication to use with this WLAN.
 - *No Authentication and No Encryption* - Configures a network without any authentication. This option also configures the network without encryption. This means that any data transmitted through the network is in plain text. Any device between end points can see the information transmitted. This is the least secure of all network configurations.
 - *Captive Portal Authentication and No Encryption* - Configures a network that uses a RADIUS server to authenticate users before allowing them on to the network. Once on the network, no encryption is used for the data being transmitted through the network. Select this option to use a Web page (either internally or externally hosted) to authenticate users before access is granted to the network.
 - *PSK authentication, WPA2 encryption* - Configures a network that uses PSK authentication and WPA2 encryption. Select this option to implement a pre-shared key that must be correctly shared between the Access Point and requesting clients using this WLAN.

21. Select **Add User** to display the dialog to enter user information to add to the RADIUS server user database.

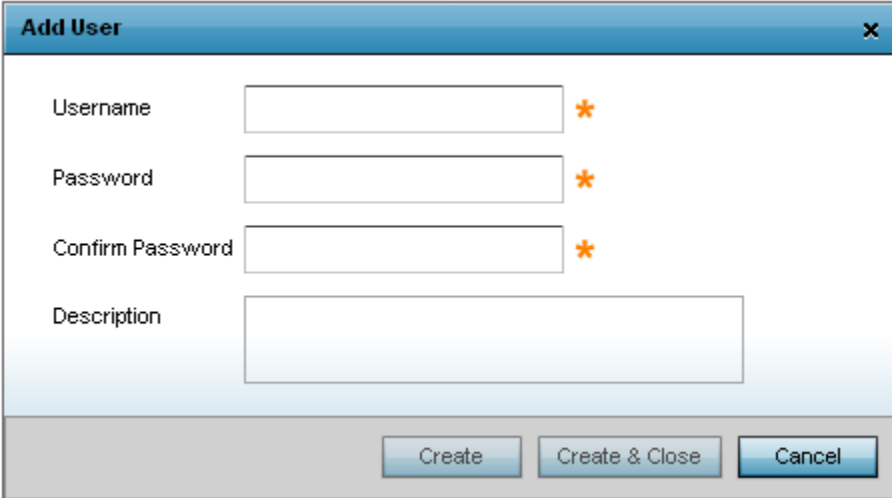

The screenshot shows a dialog box titled "Add User" with a close button (X) in the top right corner. The dialog contains four input fields: "Username", "Password", "Confirm Password", and "Description". Each of the first three fields has a red asterisk (*) to its right, indicating they are required. At the bottom of the dialog, there are three buttons: "Create", "Create & Close", and "Cancel".

22. Enter the following user information:
 - *Username* - Provide a user name used to authenticate the user.
 - *Password* - Provide a password used to authenticate the user.
 - *Confirm Password* - Confirm the password by entering the same password as entered in the Password field.
 - *Description* - Provide a description to identify the user created in the RADIUS server database.
23. To create the entry in the RADIUS server database and add another user, select **Create**. To create the entry in the RADIUS server database and close the Add User dialog, select **Create & Close**.
24. Select **Modify User** on the RADIUS Server Configuration screen to modify information for an existing user from the RADIUS database. Highlight the user entry then select **Modify User**.



NOTE The *Username* cannot be modified with this dialog.

25. Select **Delete User** on the RADIUS Server Configuration screen to remove information for an existing user from the RADIUS database. Highlight the user entry and select **Delete User**.
26. Select **Confirm** on the dialog displayed. The entry for the user is removed from the RADIUS database.
27. To dismiss the dialog without adding, modifying or removing entries in the RADIUS server database, select **Cancel**.

28. Select **Next**. The Typical Setup Wizard displays the **Summary and Commit** screen to summarize the screens (pages) and settings updated using the Typical Setup Wizard.



Access Point Type Page

Access Point Type Standalone AP



Networking Mode Page

Networking Mode Router Mode



LAN Configuration Page

LAN Configuration Type Static IP Address/Subnet

VLAN ID for the LAN Interface 1

Static IP Address/Subnet 192.168.13.23/24



WAN Configuration Page

WAN Configuration Type Use DHCP

Port to External GE1 Port



WLAN Configuration

No user intervention or additional settings are required. Its an additional means of validating the Access Point's updated configuration before it's deployed. However, if a screen displays settings not intended as part of the initial configuration, then any screen can be selected again from within the Navigation Panel and its settings modified accordingly.

29. If the configuration displays as intended, select **Save/Commit** to implement these settings to the Access Point's configuration. If additional changes are warranted based on the summary, either select the target page from the **Navigational Panel**, or use the **Back** and **Next** buttons to scroll to the target screen.

4 Specifications

4.1 AP-6562 Internal Antenna Model Power Specifications

An AP-6562 internal model access point has the following power specifications:

<i>Operating voltage</i>	36-57 VDC
<i>Power in (PoE)</i>	802.3at

4.2 AP-6562 Internal Antenna Model Physical Specifications

An AP-6562 internal antenna model access point has the following physical specifications:

<i>Dimensions</i>	9.1 in W x 9.8 in H x 2.6 in D 23.1cm W x 24.9cm H x 24.9cm D
<i>Enclosure</i>	IP 67 rated, polymeric corrosion resistant, ASTM B117 salt, fog, and rust resistant
<i>Weight</i>	2.90 lbs / 1.3 kg
<i>Operating temperature</i>	-22°F to +140°F/-30°C to +60°C
<i>Storage temperature</i>	-40°F to +185°F/-40°C to +85°C
<i>Operating humidity</i>	5 to 95% Relative Humidity non-condensing
<i>Storage humidity</i>	85% Relative Humidity non-condensing
<i>Operating altitude (maximum)</i>	8,000 ft/2438.4 m
<i>Storage altitude (maximum)</i>	30,000 ft/9144.0 m
<i>Electrostatic discharge</i>	EN61000-4-2 Air +/-15kV, Contact +/-8kV
<i>Operational shock</i>	IE60721-3-4, Class 4M3, MIL STD 810F
<i>Operational vibration</i>	IE60721-3-4, Class 4M3

4.3 AP-6562 Internal Antenna Model Antenna Specifications

An AP-6562 internal antenna model access point has the following antenna specifications:

<i>Radio 1</i>	2.4GHz@5.0dBi
<i>Radio 2</i>	2.4GHz@3.0dBi, 5.0GHz@6.0dBi

4.4 AP-6562 External Antenna Model Power Specifications

An AP-6562 external antenna model access point has the following power specifications:

<i>Operating voltage</i>	36-57 VDC
<i>Power in (PoE)</i>	802.3at

4.5 AP-6562 External Antenna Model Physical Specifications

An AP-6562 external antenna model access point has the following physical specifications:

<i>Dimensions</i>	9.1 in W x 9.8 in H x 2.6 in D 23.1cm W x 24.9cm H x 24.9cm D
<i>Enclosure</i>	IP 67 rated, polymeric corrosion resistant, ASTM B117 salt, fog, and rust resistant
<i>Weight</i>	2.90 lbs / 1.3 kg
<i>Operating temperature</i>	-22°F to +140°F/-30°C to +60°C
<i>Storage temperature</i>	-40°F to +185°F/-40°C to +85°C
<i>Operating humidity</i>	5 to 95% Relative Humidity non-condensing
<i>Storage humidity</i>	85% Relative Humidity non-condensing
<i>Operating altitude (maximum)</i>	8,000 ft/2438.4 m
<i>Storage altitude (maximum)</i>	30,000 ft/9144.0 m
<i>Electrostatic discharge</i>	EN61000-4-2 Air +/-15kV, Contact +/-8kV
<i>Operational shock</i>	IE60721-3-4, Class 4M3, MIL STD 810F
<i>Operational vibration</i>	IE60721-3-4, Class 4M3

4.6 Radio Specifications

AP-6562 model access points have the following radio specifications:

<i>Data rates supported</i>	802.11b/g: 1,2,5.5,11,6,9,12,18,24,36,48, and 54Mbps 802.11a: 6,9,12,18,24,36,48, and 54Mbps 802.11n: MCS 0-15 up to 300Mbps
<i>Network standard</i>	802.11a, 802.11b, 802.11g, 802.11n
<i>Wireless medium</i>	<i>Direct Sequence Spread Spectrum</i> (DSSS), <i>Orthogonal Frequency Division Multiplexing</i> (OFDM) <i>Spatial multiplexing</i> (MIMO)
<i>Uplink</i>	Auto-sensing 10/100/1000 Base-T Ethernet
<i>Operating Channels</i>	Radio 1: 2.4GHz channel 1-13 (2412-2472Mhz), Channel 14 (2484MHZ) Japan only Radio 2: 2.4GHz2.4GHz channel 1-13 (2412-2472Mhz), Channel 14 (2484MHZ) Japan only, 5GHz all channels from 5200MHz-5825MHz Actual operating frequencies depend upon national regulatory limits.
<i>Maximum available transmit power</i>	2.4GHz: 21dBm per chain 5.0GHz: 20dBm per chain
<i>Maximum radio transmit power</i>	2400MHz band: Single antenna transmit power: +21dBm Dual antenna composite transmit power: +24dBm 5200MHz band: Single antenna transmit power: +20dBm Dual antenna composite transmit power: +23dBm
<i>Transmit power adjustment</i>	1dB increments

5 Regulatory Information

This guide applies to MODEL: AP-6562

All Zebra devices are designed to be compliant with rules and regulations in locations they are sold and will be labeled as required.

Any changes or modifications to Zebra equipment, not expressly approved by Zebra, could void the user's authority to operate the equipment.

Zebra devices are professionally installed, the Radio Frequency Output Power will not exceed the maximum allowable limit for the country of operation.

Antennas: Use only the supplied or an approved replacement antenna. Unauthorized antennas, modifications, or attachments could cause damage and may violate regulations.

This device is only to be used with a Symbol Wireless Switch.

5.1 Country Approvals

5.2 Wireless Device Country Approvals

Regulatory markings, subject to certification, are applied to the device signifying the radio(s) is/are approved for use in the following countries: United States, Canada, Japan, China, S. Korea, Australia, and Europe.

Please refer to the Declaration of Conformity (DoC) for details of other country markings. This is available at: www.zebra.com/doc.

Note: Europe includes, Austria, Belgium, Bulgaria, Czech Republic, Cyprus, Denmark, Estonia, Finland, France, Germany, Greece, Hungary, Iceland, Ireland, Italy, Latvia, Liechtenstein, Lithuania, Luxembourg, Malta, Netherlands, Norway, Poland, Portugal, Romania, Slovak Republic, Slovenia, Spain, Sweden, Switzerland and the United Kingdom.



Operation of the device without regulatory approval is illegal.

5.2.1 Country Selection

Select only the country in which you are using the device. Any other selection will make the operation of this device illegal.

5.2.2 Frequency of Operation – FCC and IC

You are reminded of the need to observe restrictions on the radio devices in fuel depots, chemical plants etc. and areas where the air contains chemicals or particles (such as grain, dust, or metal powders).

5 GHz Only

The use in the UNII (Unlicensed National Information Infrastructure) band 1 (5150-5250 MHz) is restricted to Indoor Use Only; any other use will make the operation of this device illegal.

Industry Canada Statement:

Caution: The device for the band 5150-5250 MHz is only for indoor usage to reduce potential for harmful interference to co-Channel mobile satellite systems. High power radars are allocated as primary users (meaning they have priority) of 5250-5350 MHz and 5650-5850 MHz and these radars could cause interference and/or damage to LE-LAN devices.

The professional installer should utilize the Antenna Guide to ensure a compliant configuration consistent with the FCC Grant and the IC Listing. The transmitter power settings for each of the authorized antennas are contained in the Antenna Guide.

Avertissement: Le dispositif fonctionnant dans la bande 5150-5250 MHz est réservé uniquement pour une utilisation à l'intérieur afin de réduire les risques de brouillage préjudiciable aux systèmes de satellites mobiles utilisant les mêmes canaux. Les utilisations de radars de haute puissance son designs utilisations principii (c.-à-d., quills not la priority) pour les bands 5250-5350 MHz et 5650-5850 MHz et que ces radars pourraient causer du brouillage et/ou des dommages aux dispositifs LAN-EL.

L'installateur professionnel devrait utiliser les Guides d'Antenne 72E-162906-01 pour garantir une configuration accommodante en accord avec la Subvention de FCC et la Liste d'IC. Les cadres de pouvoir de transmetteur pour chacune des antennes autorisées sont contenus dans le Guide d'Antenne.

2.4 GHz Only

The available channels for 802.11 b/g operation in the US are Channels 1 to 11. The range of channels is limited by firmware.

5.3 Health and Safety Recommendations

5.3.1 Warnings for Wireless Devices



Please observe all warning notices with regard to the usage of wireless devices.

5.3.2 Potentially Hazardous Atmospheres - Fixed Installations

You are reminded of the need to observe restrictions on the radio devices in fuel depots, chemical plants etc. and areas where the air contains chemicals or particles (such as grain, dust, or metal powders).

5.3.3 Safety in Hospitals



Wireless devices transmit radio frequency energy and may affect medical electrical equipment. When installed adjacent to other equipment, it is advised to verify that the adjacent equipment is not adversely affected.

Pacemakers

Pacemaker manufacturers recommended that a minimum of 15cm (6 inches) be maintained between a handheld wireless device and a pacemaker to avoid potential interference with the pacemaker. These recommendations are consistent with independent research and recommendations by Wireless Technology Research.

Persons with Pacemakers:

- Should ALWAYS keep the device more than 15cm (6 inches) from their pacemaker when turned ON.
- Should not carry the device in a breast pocket.
- Should use the ear furthest from the pacemaker to minimize the potential for interference.
- If you have any reason to suspect that interference is taking place, turn OFF your device.

Other Medical Devices

Please consult your physician or the manufacturer of the medical device, to determine if the operation of your wireless product may interfere with the medical device.

5.4 RF Exposure Guidelines

5.4.1 Reducing RF Exposure - Use Properly

Only operate the device in accordance with the instructions supplied.

5.4.2 International

The device complies with internationally recognized standards covering human exposure to electromagnetic fields from radio devices. For information on “International” human exposure to electromagnetic fields refer to the *Declaration of Conformity* (DoC) at: www.zebra.com/doc.

5.5 Europe

Remote and Standalone Antenna Configurations

To comply with EU RF exposure requirements, antennas that are mounted externally at remote locations or operating near users at stand-alone desktop or similar configurations must operate with a minimum separation distance of 20 cm from all persons.

5.6 US and Canada

Co-located statement

To comply with FCC RF exposure compliance requirement, the antennas used for this transmitter must not be co-located or operating in conjunction with any other transmitter/antenna except those already approved in this filling.

Remote and Standalone Antenna Configurations

To comply with FCC RF exposure requirements, antennas that are mounted externally at remote locations or operating near users at stand-alone desktop of similar configurations must operate with a minimum separation distance of 20 cm from all persons.

To satisfy FCC RF exposure requirements, a mobile transmitting device must operate with a minimum separation distance of 20 cm or more from a person's body.

5.7 Power Supply

Use ONLY an AP-PSBIAS-7161-US or AP-PSBIAS-7161-WW outdoor rated power supply.

This device can be powered from a 802.3at compliant power source which is certified by the appropriate agencies.

Use of alternative Power Supply will invalidate any approvals given to this unit and may be dangerous.

5.8 Radio Frequency Interference Requirements—FCC



This equipment has been tested and found to comply with the limits for a Class B digital device, pursuant to Part 15 of the FCC rules. These limits are designed to provide reasonable protection against harmful interference in a residential installation. This equipment generates, uses and can radiate radio frequency energy and, if not installed and used in accordance with the instructions,

may cause harmful interference to radio communications. However there is no guarantee that interference will not occur in a particular installation. If this equipment does cause harmful interference to radio or television reception, which can be determined by turning the equipment off and on, the user is encouraged to try to correct the interference by one or more of the following measures:

- Reorient or relocate the receiving antenna
- Increase the separation between the equipment and receiver
- Connect the equipment into an outlet on a circuit different from that to which the receiver is connected
- Consult the dealer or an experienced radio/TV technician for help.

Radio Transmitters (Part 15)

This device complies with Part 15 of the FCC Rules. Operation is subject to the following two conditions: (1) this device may not cause harmful interference, and (2) this device must accept any interference received, including interference that may cause undesired operation.

5.9 Radio Frequency Interference Requirements – Canada

This Class B digital apparatus complies with Canadian ICES-003.

Cet appareil numérique de la classe B est conforme à la norme NMB-003 du Canada.

This device complies with Industry Canada licence-exempt RSS standard(s) Rules. Operation is subject to the following two conditions: (1) this device may not cause harmful interference, and (2) this device must accept any interference received, including interference that may cause undesired operation.

Cet appareil se conforme Canada et Industrie Règles de normes de RSS permis-exempt. L'opération est assujetti au suivre deux conditions : (1) cet appareil ne peut pas causer l'intervention nuisible, et (2) cet appareil doit accepter de l'intervention reçue, y compris l'intervention qui peut causer l'opération non désirée.

Radio Transmitters

For RLAN Devices:

The 5 GHz RLAN's, for use in Canada, have the following restrictions:

- Restricted Band 5.60 – 5.65 GHz

This device complies with RSS 210 of Industry Canada. Operation is subject to the following two conditions: (1) this device may not cause harmful interference and (2) this device must accept any interference received, including interference that may cause undesired operation.

Ce dispositif est conforme à la norme CNR-210 d'Industrie Canada applicable aux appareils radio exempts de licence. Son fonctionnement est sujet aux deux conditions suivantes: (1) le dispositif ne doit pas produire de brouillage préjudiciable, et (2) ce dispositif doit accepter tout brouillage reçu, y compris un brouillage susceptible de provoquer un fonctionnement indésirable.

This radio transmitter (identify the device by certification number, or model number if Category II) has been approved by Industry Canada to operate with the antenna types listed in the Antenna Guides 72E-162906-01 with the maximum permissible gain and required antenna impedance for each antenna type indicated. Antenna types not included in guide, having a gain greater than the maximum gain indicated for that type, are strictly prohibited for use with this device.

Cet émetteur radio (identifiez l'artifice par le nombre de certification, ou nombre modèle si la Catégorie II) a été approuvé par l'Industrie le Canada pour opérer avec les types d'antenne énumérés dans l'Antenne Guide 72E-162906-01 avec l'augmentation permise maximum et a exigé l'impédance d'antenne pour chaque type d'antenne indiqué. Les types d'antenne non inclus dans le guide, en ayant une augmentation plus grande que l'augmentation maximum indiquée pour ce type, sont sévèrement interdits pour l'utilisation avec cet artifice.

Label Marking: The Term "IC." before the radio certification signifies that Industry Canada technical specifications were met.

5.10 CE Marking and European Economic Area (EEA)

The use of 2.4GHz RLAN's, for use through the EEA, have the following restrictions:

- Maximum radiated transmit power of 100 mW EIRP in the frequency range 2.400 -2.4835 GHz.
- France outside usage, the equipment is restricted to 2.400-2.45 GHz frequency range.
- Italy requires a user license for outside usage.

5.11 Statement of Compliance

Zebra hereby declares that this device is in compliance with the essential requirements and other relevant provisions of Directive 1999/5/EC. A Declaration of Conformity may be obtained from www.zebra.com/doc.

5.12 Korea Warning Statement for Class B ITE

기종별	사용자안내문
B 급 기기 (가정용 방송통신기기)	이 기기는 가정용 (B 급) 으로 전자파적합등록을 한 기기로서 주로 가정에서 사용하는 것을 목적으로 하며, 모든 지역에서 사용할 수 있습니다
Class B (Broadcasting Communication Device for Home Use)	This device obtained EMC registration mainly for home use (Class B) and may be used in all areas.

5.13 Other Countries

Australia

Use of 5GHz RLAN's in Australia is restricted in the following band 5.50 – 5.65GHz.

Brazil

Declarações Regulamentares para AP-6522 - Brasil

Nota: A marca de certificação se aplica ao Transceptor, modelo AP-6522. Este equipamento opera em caráter secundário, isto é, não tem direito a proteção contra interferência prejudicial, mesmo de estações do mesmo tipo, e não pode causar interferência a sistemas operando em caráter primário. Para maiores informações sobre ANATEL consulte o site: www.anatel.gov.br

Chile

Este equipo cumple con la Resolución No 403 de 2008, de la Subsecretaria de telecomunicaciones, relativa a radiaciones electromagnéticas.

Mexico

Restrict Frequency Range to: 2.450 – 2.4835 GHz.

Taiwan

臺灣

低功率電波輻射性電機管理辦法

第十二條

經型式認證合格之低功率射頻電機，非經許可，公司、商號或使用者均不得擅自變更頻率、加大功率或變更原設計之特性及功能。

第十四條

低功率射頻電機之使用不得影響飛航安全及干擾合法通信；經發現有干擾現象時，應立即停用，並改善至無干擾時方得繼續使用。

前項合法通信，指依電信規定作業之無線電通信。

低功率射頻電機須忍受合法通信或工業、科學及醫療用電波輻射性電機設備之干擾。

在 5.25-5.35 兆赫頻帶內操作之無線資訊傳輸設備，限於室內使用

Korea

당해 무선설비는 운용 중 전파혼신 가능성이 있음

당해 무선설비는 전파혼신 가능성이 있으므로 인명안전과 관련된 서비스는 할 수 없습니다.

5.14 Waste Electrical and Electronic Equipment (WEEE)



English: For EU Customers: All products at the end of their life must be returned to Zebra for recycling. For information on how to return product, please go to: www.zebra.com/weee.

Français: Clients de l'Union Européenne: Tous les produits en fin de cycle de vie doivent être retournés à Zebra pour recyclage. Pour de plus amples informations sur le retour de produits, consultez : www.zebra.com/weee.

Español: Para clientes en la Unión Europea: todos los productos deberán entregarse a Zebra al final de su ciclo de vida para que sean reciclados. Si desea más información sobre cómo devolver un producto, visite: www.zebra.com/weee.

Български: За клиенти от ЕС: След края на полезния им живот всички продукти трябва да се връщат на Zebra за рециклиране. За информацията относно връщането на продукти, моля отидете на адрес: www.zebra.com/weee.

Deutsch: Für Kunden innerhalb der EU: Alle Produkte müssen am Ende ihrer Lebensdauer zum Recycling an Zebra zurückgesandt werden. Informationen zur Rücksendung von Produkten finden Sie unter www.zebra.com/weee.

Italiano: per i clienti dell'UE: tutti i prodotti che sono giunti al termine del rispettivo ciclo di vita devono essere restituiti a Zebra al fine di consentire il riciclaggio. Per informazioni sulle modalità di restituzione, visitare il seguente sito Web: www.zebra.com/weee.

Português: Para clientes da UE: todos os produtos no fim de vida devem ser devolvidos à Zebra para reciclagem. Para obter informações sobre como devolver o produto, visite: www.zebra.com/weee.

Nederlands: Voor klanten in de EU: alle producten dienen aan het einde van hun levensduur naar Zebra te worden teruggezonden voor recycling. Raadpleeg www.zebra.com/weee voor meer informatie over het terugzenden van producten.

Polski: Klienci z obszaru Unii Europejskiej: Produkty wycofane z eksploatacji należy zwrócić do firmy Zebra w celu ich utylizacji. Informacje na temat zwrotu produktów znajdują się na stronie internetowej www.zebra.com/weee.

Čeština: Pro zákazníky z EU: Všechny produkty je nutné po skončení jejich životnosti vrátit společnosti Zebra k recyklaci. Informace o způsobu vrácení produktu najdete na webové stránce: www.zebra.com/weee.

Eesti: EL klientidele: kõik tooted tuleb nende eluea lõppedes tagastada taaskasutamise eesmärgil Zebra'ile. Lisainformatsiooni saamiseks toote tagastamise kohta külastage palun aadressi: www.zebra.com/weee.

Magyar: Az EU-ban vásárlóknak: Minden tönkrement terméket a Zebra vállalathoz kell eljuttatni újrahasznosítás céljából. A termék visszajuttatásának módjával kapcsolatos tudnivalóként látogasson el a www.zebra.com/weee weboldalra.

Svenska: För kunder inom EU: Alla produkter som uppnått sin livslängd måste returneras till Zebra för återvinning. Information om hur du returnerar produkten finns på www.zebra.com/weee.

Suomi: Asiakkaat Euroopan unionin alueella: Kaikki tuotteet on palautettava kierrätettäväksi Zebra-yhtiöön, kun tuotetta ei enää käytetä. Lisätietoja tuotteen palauttamisesta on osoitteessa www.zebra.com/weee.

Dansk: Til kunder i EU: Alle produkter skal returneres til Zebra til recirkulering, når de er udtjent. Læs oplysningerne om returnering af produkter på: www.zebra.com/weee.

Ελληνικά: Για πελάτες στην Ε.Ε.: Όλα τα προϊόντα, στο τέλος της διάρκειας ζωής τους, πρέπει να επιστρέφονται στην Zebra για ανακύκλωση. Για περισσότερες πληροφορίες σχετικά με την επιστροφή ενός προϊόντος, επισκεφθείτε τη διεύθυνση www.zebra.com/weee στο Διαδίκτυο.

Malti: Għal klijenti fl-UE: il-prodotti kollha li jkunu waslu fl-aħħar tal-ħajja ta' l-użu tagħhom, iridu jiġu rritornati għand Zebra għar-riċiklaġġ. Għal aktar taġġir dwar kif għandek tirritorna l-prodott, jekk jogħġbok żur:

www.zebra.com/weee.

Românesc: Pentru clienții din UE: Toate produsele, la sfârșitul duratei lor de funcționare, trebuie returnate la Zebra pentru reciclare. Pentru informații despre returnarea produsului, accesați: www.zebra.com/weee.

Slovenski: Za kupce v EU: vsi izdelki se morajo po poteku življenjske dobe vrniti podjetju Zebra za reciklažo. Za informacije o vračilu izdelka obiščite: www.zebra.com/weee.

Slovenčina: Pre zákazníkov z krajín EU: Všetky výrobky musia byť po uplynutí doby ich životnosti vrátené spoločnosti Zebra na recykláciu. Bližšie informácie o vrátení výrobkov nájdete na: www.zebra.com/weee.

Lietuvių: ES vartotojams: visi gaminiai, pasibaigus jų eksploatacijos laikui, turi būti grąžinti utilizuoti į kompaniją „Zebra“. Daugiau informacijos, kaip grąžinti gaminį, rasite: www.zebra.com/weee.

Latviešu: ES klientiem: visi produkti pēc to kalpošanas mūža beigām ir jānogādā atpakaļ Zebra otrreizējai pārstrādei. Lai iegūtu informāciju par produktu nogādāšanu Zebra, lūdzu, skatiet: www.zebra.com/weee.

Türkçe: AB Müşterileri için: Kullanım süresi dolan tüm ürünler geri dönüşürme için Zebra'ya iade edilmelidir. Ürünlerin nasıl iade edileceği hakkında bilgi için lütfen şu adresi ziyaret edin: www.zebra.com/weee.

Turkish WEEE Statement of Compliance

EEE Yönetmeliğine Uygundur

6 Support

If you have a problem with your equipment, contact support for your region.

Contact information is available at: www.zebra.com/support.

When contacting support, please provide the following information:

- Serial number of the unit
- Model number or product name
- Software type and version number

Support responds to calls by e-mail, telephone, or fax within the time limits set forth in support agreements. If you purchased your product from a business partner, contact that business partner for support.

6.1 Customer Support Web Sites

Support located at: www.zebra.com/support provides information and online assistance including developer tools, software downloads, product manuals and online repair requests.

6.2 Manuals

Documentation is available at: www.zebra.com/support.

7 AP-6522 Series Access Point China ROHS Compliance

部件名称 (Parts)	有害物质 					
	铅 (Pb)	汞 (Hg)	镉 (Cd)	六价铬 (Cr(VI))	多溴联 苯 (PBB)	多溴二苯 醚 (PBDE)
金属部件 (Metal Parts)	○	○	○	○	○	○
电路模块 (Circuit Modules)	X	○	○	○	○	○
电缆及电缆组件 (Cables and Cable Assemblies)	○	○	○	○	○	○
塑料和聚合物部件 (Plastic and Polymeric Parts)	○	○	○	○	○	○
光学和光学组件 (Optics and Optical Components)	○	○	○	○	○	○
电池 (Batteries)	○	○	○	○	○	○

本表格依据 SJ/T 11364 的规定编制。

○: 表示该有害物质在该部件所有均质材料中的含量均在 GB/T 26572 规定的限量要求以下。

X: 表示该有害物质至少在该部件的某一均质材料中的含量超出 GB/T 26572 规定的限量要求。(企业可在此处, 根据实际情况对上表中打“x”的技术原因进行进一步说明。)

This table was created to comply with China RoHS requirements for the AP-6522 Access Point.



Zebra Technologies Corporation
Lincolnshire, IL 60069 USA

Zebra and the Zebra head graphic are registered trademarks of ZIH Corp. The Symbol logo is a registered trademark of Symbol Technologies, Inc., a Zebra Technologies company.

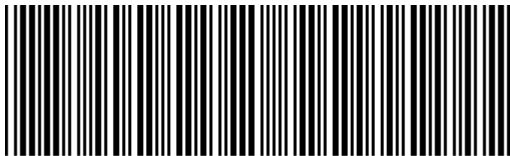

MN001370A01 Revision B April 2015

