

Enterprise Wireless LAN Antenna

Specification Guide

Version 2.1 Rev B July 2012

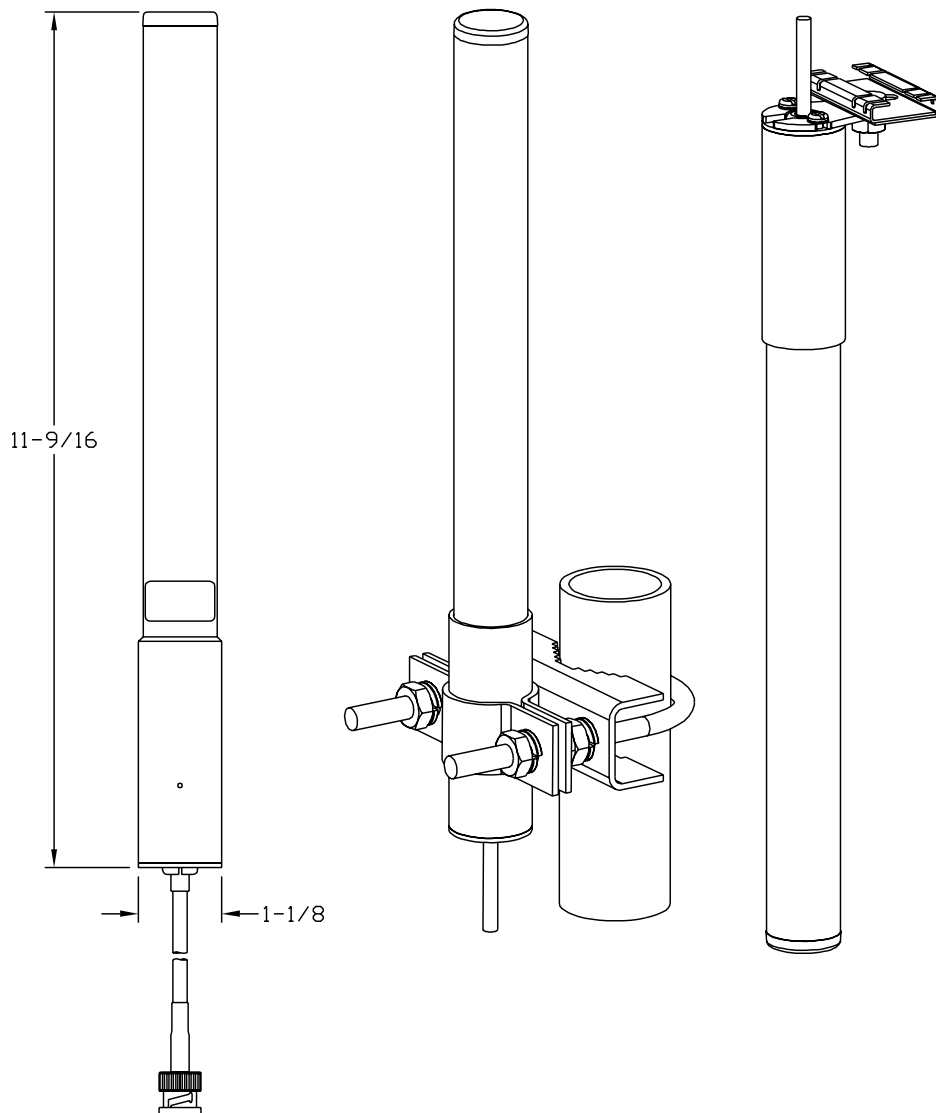

© 2012 Motorola Solutions, Inc. All rights reserved.

MOTOROLA and the Stylized M Logo are registered in the US Patent & Trademark Office. .

Contents

Chapter 1. Antenna Selection and Description

1.1 Antenna Selection	1-1
1.2 Antenna Selection Criteria	1-6
1.3 Antenna Accessories for Enterprise WLANs	1-7

Chapter 2. Product Compatibility

2.1 FCC Compliance	2-1
2.2 FCC Approval Statement	2-3
2.3 FCC USA Compaibility Matrix	2-6

Chapter 3. 2.4 GHz Single Band Antenna Suite

3.1 Supported 802.11b/g/n Antenna Suite	3-1
---	-----

Chapter 4. 5.2 Ghz Single Band Antenna Suite

4.1 Supported 802.11a/n Antenna Suite	4-1
---	-----

Chapter 5. 2.4GHz - 5.2GHz Dual Band Antenna Suite

5.1 Supported 802.11a/b/g/n Dual Band Antennas	5-1
--	-----

Chapter 6. Antenna Cables

6.1 Supported Antenna Cables	6-1
------------------------------------	-----

Chapter 7. Supported Antenna Adapters

7.1 Supported Adapters	7-1
------------------------------	-----

Chapter 8. Supported Lightning Arrestors

8.1 Lightning Arrestors	8-1
-------------------------------	-----

Chapter 9. Mounting Kits

9.1 Mounting Kit Support	9-1
--------------------------------	-----

Chapter 10. AP-5131 Antenna Connections

10.1 2.4 GHz AP-5131 Antenna Connections	10-2
10.2 5 GHz AP-5131 Antenna Connections	10-9

Chapter 11. AP300 Antenna Connections

11.1 2.4 GHz AP300 Antenna Connections	11-1
11.2 5 GHz AP300 Antenna Connections	11-8

Chapter 12. AP7131 Transmit Power

12.1 Configuring the AP7131 Series Transmit Power	12-1
12.2 US Regulatory Domain 2.4 GHz Band	12-8
12.3 US Regulatory Domain 5.2 GHz Band	12-13
12.4 Japanese TELEC Regulatory Domain 2.4 GHz Band	12-23
12.5 Japan TELEC Regulatory Domain 5.2 GHz Band	12-27

Chapter 13. AP650 Regulatory Domains

13.1 US Regulatory Domain 2.4 GHz Band	13-1
13.2 US Regulatory Domain 5 GHz Band	13-6
13.3 Japan TELEC Regulatory Domain 2.4 GHz Band	13-16
13.4 Japan TELEC Regulatory Domain 5 GHz Band	13-22
13.5 EU Regulatory Domain 2.4 GHz Band	13-34
13.6 EU Regulatory Domain 5 GHz Band	13-39

Chapter 14. RFS4011 Regulatory Domains

14.1 US Regulatory Domain 2.4 GHz Band	14-1
14.2 US Regulatory Domain 5 GHz Band	14-5
14.3 Canada Regulatory Domain 2.4 GHz Band	14-13
14.4 Canada Regulatory Domain 5 GHz Band	14-17
14.5 EU Regulatory Domain 2.4 GHz Band	14-25
14.6 EU Regulatory Domain 5 GHz Band	14-29
14.7 Japan Regulatory Domain 2.4 GHz Band	14-37
14.8 Japan Regulatory Domain 5 GHz Band	14-41

Chapter 15. AP-6511 Regulatory Domains

15.1 US Regulatory Domain 2.4 GHz Band	15-1
15.2 US Regulatory Domain 5 GHz Band	15-2
15.3 EU Regulatory Domain 2.4 GHz Band	15-3
15.4 EU Regulatory Domain 5 GHz Band	15-4
15.5 Japan Regulatory Domain 2.4 GHz Band	15-6
15.6 Japan Regulatory Domain 5 GHz Band	15-7

Chapter 16. AP-621 and AP-6521 Regulatory Domains

16.1 AP-621 (Standard Power) US Regulatory Domain 2.4GHz Band	16-1
16.2 AP-621 (Standard Power) US Regulatory Domain 5GHz Band	16-5
16.3 AP-6521 (High Power) US Regulatory Domain 2.4GHz Band	16-13
16.4 AP-6521 (High Power) US Regulatory Domain 5GHz Band	16-17
16.5 AP-621 (Standard Power) EU Regulatory Domain 2.4GHz Band	16-25
16.6 AP-621 (Standard Power) EU Regulatory Domain 5GHz Band	16-29
16.7 AP6521 (High Power) EU Regulatory Domain 2.4GHz Band	16-37
16.8 AP-6521 (High Power) EU Regulatory Domain 5GHz Band	16-41
16.9 AP-621 (Standard Power) Japan Regulatory Domain 2.4GHz Band	16-49
16.10 AP-621 (Standard Power) Japan Regulatory Domain 5GHz Band	16-53

16.11 AP-6521 (High Power) Japan Regulatory Domain 2.4GHz Band	16-61
16.12 AP-6521 (High Power) Japan Regulatory Domain 5GHz Band	16-65

Chapter 17. AP622 Regulatory Domains

17.1 US Regulatory Domain 2.4 GHz Band	17-1
17.2 US Regulatory Domain 5 GHz Band	17-6
17.3 EU Regulatory Domain 2.4 GHz Band	17-16
17.4 EU Regulatory Domain 5 GHz Band	17-21

Chapter 18. AP7161 Regulatory Domains

18.1 US Regulatory Domain 2.4 GHz Band	18-1
18.2 US Regulatory Domain 4.9 GHz Band	18-2
18.3 US Regulatory Domain 5 GHz Band	18-3
18.4 EU Regulatory Domain 2.4 GHz Band	18-5
18.5 EU Regulatory Domain 5 GHz Band	18-6
18.6 Japan Regulatory Domain 2.4 GHz Band	18-8
18.7 Japan Regulatory Domain 5 GHz Band	18-9

Chapter 19. AP8132 Regulatory Domains

19.1 US Regulatory Domain 2.4 GHz Band	19-1
19.2 US Regulatory Domain 5 GHz Band	19-6
19.3 EU Regulatory Domain 2.4 GHz Band	19-16
19.4 EU Regulatory Domain 5 GHz Band	19-20

Appendix A. Technical Support

About This Guide

Introduction

This guide provides a Professional RF engineer a catalog of antennas, parts, and accessories to complete a customized RF installation of Motorola Solutions Enterprise Access Points. This guide specifically addresses the antennas used for 2.4 GHz, 5.2 GHz and dual band antenna implementations for *Wireless Local Area Networks* (WLANs).

It's important to understand that antenna and accessory selection should be qualified by on-site verification with the actual components used. Signal attenuation is cumulative with each connection and component added between the antenna and the radio, so careful study and planning should be used to verify the given arrangement ensures a compliant installation.



NOTE: Illustrations displayed in this guide are samples and can differ from the actual antenna.

Document Conventions

The following conventions are used in this document to draw your attention to important information:



NOTE: Indicate tips or special requirements.



CAUTION: Indicates conditions that can cause equipment damage or data loss.



WARNING! Indicates a condition or procedure that could result in personal injury or equipment damage.

Notational Conventions

The following additional notational conventions are used in this document:

- *Italics* are used to highlight the following:
 - Chapters and sections in this and related documents
 - Dialog box, window and screen names
 - Drop-down list and list box names
 - Check box and radio button names
 - Icons on a screen.
- **GUI** text is used to highlight the following:
 - Screen names
 - Menu items
 - Button names on a screen.
- bullets (•) indicate:
 - Action items
 - Lists of alternatives
 - Lists of required steps that are not necessarily sequential
- Sequential lists (those that describe step-by-step procedures) appear as numbered lists.

Antenna Selection and Description

1.1 Antenna Selection

While several antennas may work in a given environment, some will provide better coverage than others. Using the right antenna in the right location will maximize both the performance and coverage of your network. Understanding the key characteristics that describe how an antenna sends and receives radio frequency signals is critical to finding the ideal antenna for your deployment. This guide supports the antennas used for AP-5131, AP-5181, AP-7131 and AP-6511 model access points, AP650 and AP300 (non-integrated antenna) model access port and the RFS4011 Integrated Services Controller.

Motorola Solutions Enterprise Wireless LAN products operate in the 2.4 GHz and 5 GHz ISM bands allocated for unlicensed use. Access point and access port products available today support either the 802.11b/g/n or the 802.11a/n standard, or both. Wireless devices conforming to the 802.11b/g standard operate in the 2.4 GHz ISM band, while 802.11a devices operate in the 5 GHz band. The antennas in this guide are grouped according to the frequency band they support. Some antennas are designed to operate within either band. These antennas (described as "Dual-band") may be connected to radios operating in either the 2.4 or 5 GHz bands, although a single antenna may not be connected to two radios at the same time.

1.1.1 Connector Types and Definitions

There are combinations of antenna types and cables required to provide a satisfactory connection to the AP. One confusing factor is "reverse polarity". Reverse polarity is the FCC's requirement for each WLAN manufacturer to have unique access point connectors. Motorola Solutions had previously standardized our offerings for access points/ports:

- 2.4 GHz is Reverse polarity BNC female (RP-BNC-F)
- 5 GHz is reverse polarity SMA female (RP-SMA-F)
- Dual Band is reverse polarity SMA female (for AP-5131), and N-Female (for AP-5181).



NOTE: Reverse polarity presents confusion because of a lack of a standardized definition from connector manufactures. Reverse polarity provides a center element, which should not be confused with a male connector. A male connector is defined by the outer jacket of the connector rather than the center element.

The following are the connectors used within this guide:



Figure 1.1 RP-BNC-F



Figure 1.2 RP-BNC-M



Figure 1.3 RP-SMA-F



Figure 1.4 RP-SMA-M

Additionally, antennas deployed outdoors and industry standard accessories (like lightning arrestors) use Type-N connectors (as displayed below). Therefore, with the combinations devices required (access points/ports, antennas, cable extensions, and lightning arrestors), various adapter cables are required to connect an antenna to an access point/port.



Figure 1.5 Type N-F



Figure 1.6 Type N-M

1.1.2 Indoor and Outdoor Antennas

One important aspect of an antenna is whether it is weather sealed to protect it from the environment. Because of this extra protection, outdoor antennas are typically more expensive than those rated for indoor use. Outdoor antennas can be used for indoor applications, such as freezers and cooler where moisture is common. Outdoor antennas can be used for indoor applications, but indoor applications should not be used in outdoor applications.

One common distinction of outdoor antennas is the connector. Since lightning protection is always advised for outdoor antennas, these antennas typically have Type N Male to directly attach the lightning arrestor. This is true of 2.4 GHz, 5 GHz, and dual-band outdoor antennas.

1.1.3 Spectrum and Part Number Designations

The antennas listed in this document are ultimately referenced by part number. A numerical sequence is used within each antenna's part number to identify the spectrum supported by the antennas.

- The antenna part numbers with a 2499 indicates a 2.4 GHz antenna. For more information on the 2.4 GHz antenna suite, see *2.4 GHz Single Band Antenna Suite on page 3-1*.
- The antenna part numbers with a 5299 indicates a 5 GHz antenna. For more information on the 2.4 GHz antenna suite, see *5.2 Ghz Single Band Antenna Suite on page 4-1*.
- The antenna part numbers with a 2452 indicates a dual band antenna (2.4GHz and 5 GHz). For more information on the 2.4 GHz antenna suite, see *2.4GHz - 5.2GHz Dual Band Antenna Suite on page 5-1*.

1.1.4 Extended AP to Antenna Cable Lengths

Most indoor antennas are intended to be mounted directly to the AP's connectors. Some mounting arrangements call for positioning the AP a significant distance away from the antenna due to serviceability or other reason. In these situations, various adapters and cable extensions are required.

In these situations be mindful of:

- The connector on the AP
- The connector on the antenna
- The spectrum being implemented
- Signal loss due to multiple connectors and long cable lengths

Combinations of these attributes present different parts required to complete the connection. The Product Compatibility matrix addresses the parts required to make a proper connection. For more information, see *FCC Compliance on page 2-1*.

1.2 Antenna Selection Criteria

In addition to antenna frequency, there is other criteria to consider when selecting an antenna.

1.2.1 Antenna Pattern

1.2.1.1 Omni-Directional

Signal radiates from the antenna in all directions on the horizontal plane.

1.2.1.2 Directional

Signal radiates in a specific direction, typically described as a beam of given width, expressed in degrees in the horizontal and vertical plane. For more information, see *Azimuth 3dB Beamwidth on page 1-7* and *Elevation 3dB Beamwidth on page 1-7*.

1.2.2 Antenna Type

1.2.2.1 Panel

A panel antenna is a flat antenna mounted to a wall or other vertical surface and radiates RF energy (radio waves) directionally away from the wall. They usually have gain greater than 5 dBi and are not suitable for omni-directional situations. Ideally suited for long hallways.

1.2.2.2 Patch

A patch antenna is a flat antenna mounted on the ceiling but whose pattern is omni-directional. Most of the energy goes out horizontally to the sides of the antenna and equal in all directions.

1.2.2.3 Dipole

A dipole antenna is a tubular antenna that can be either a pipe shape, a straight flexible rod or a paddle. This antenna has an omni-directional pattern when placed in a vertical position. It usually has 2 dBi of gain.

1.2.2.4 Dipole Array

Essentially a dipole, a dipole array is two or more dipoles that are placed one on top of the other, requiring a longer tube to hold them. The advantage of a dipole array is that it has higher gain.

1.2.2.5 Parabolic Grid

A parabolic grid antenna is a very directional, dish-like antenna. Its parabolic reflector focuses the RF energy like a flashlight. Most of the time the radiating element is a dipole, but when combined with the dish, it becomes very directional with gain up to 24 dBi. Usually used in long point-to-point systems.

1.2.2.6 Yagi

A yagi antenna is an antenna that has an internal structure resembling that of typical antennas used for TV reception (a series of rods perpendicular to a main rod, making a triangular shape). This is a directional antenna with less gain than the PGA, typically around 13 dBi. It may be used in either point-to-point situations, or to cover a very long, narrow area in point-to-multi-point situations.

1.2.3 Antenna Performance Characteristics

1.2.3.1 Frequency

The frequency band within which the antenna performs at the stated specifications

1.2.3.2 Gain (dBi)

The relative amplification of the antenna with respect to an equivalent isotropic antenna, expressed on the decibel logarithmic scale.

1.2.3.3 Cable loss (dB)

The signal strength loss introduced by the cable connected to the antenna expressed on the decibel logarithmic scale.

1.2.3.4 Net gain (dBi)

The resulting amplification of the antenna paired with its cable.

1.2.3.5 Polarization

The orientation of the electrical field which the antenna is optimized to receive. If the transmitting and receiving antennas are both linear polarized, then turning one 90° so that they are cross polarized will reduce the range significantly.

1.2.3.6 VSWR

Voltage Standing Wave Ratio (VSWR) is the ratio of maximum voltage to minimum voltage along the line. Expresses the degree of match between the transmission line and the terminating element (antenna). When VSWR is 1:1 the match is perfect, a VSWR of 1.5:1 corresponds to 96% power efficiency.

1.2.3.7 Azimuth 3dB Beamwidth

Width of the antenna beam on the horizontal plane expressed in degrees.

1.2.3.8 Elevation 3dB Beamwidth

Height of the antenna beam on the vertical plane expressed in degrees.

1.3 Antenna Accessories for Enterprise WLANs

Motorola Solutions offers a complete selection of antennas and accessories to ensure optimal coverage and performance for wireless LANs. Regardless of the size or layout of your environment, from a small office or storefront to campus-wide, multiple-site, indoor and outdoor deployments, Motorola Solutions offers the antennas, cables and accessories designed to fit your needs.

By combining this portfolio with a broad line of wireless switches, access ports, access points, client connectivity cards, ruggedized mobile voice/data devices and network management software, as well as wireless mobility planning and deployment services, Motorola Solutions offers comprehensive end-to-end wireless enterprise LAN solutions, giving you secure, reliable access to your critical business data and applications at the point of activity. For more information on Motorola Solutions's wireless products, visit www.motorolasolutions.com.

1.3.1 Choosing the Right Antenna and accessories for your WLAN

It is important to consider a number of factors when choosing an antenna and accessories for your Motorola Solutions enterprise WLAN. To choose the right components, you'll need to know:

- Where is the antenna to be installed, and what type of coverage is required. Knowing the intended radio band is central. Determine if the intended radio coverage area supports dual 2.4/5.2 band traffic. Has the attenuation of the coverage been discerned in respect to known barriers.
- The band (802.11b/g/n or 802.11a/n) your network supports
- Which Motorola Solutions AP to use
- Whether you will be deploying the network indoors or outdoors
- The distance between AP and antenna, to determine extender cable length, if any
- The serviceability requirement for each AP and antenna deployment

Review the chart to determine which antennas suit your needs. Using the part numbers provided, determine which of the antennas will work with your hardware in your environment.

2

Product Compatibility

To find the right antenna and accessories for your deployment:

- Find your access point or access port model at the top of the chart (refer to the chart on the following page). Follow that column down to find the antennas, cables and lightning arrestors compatible with that model access port or access point. Write those part numbers down.
- Follow the row antenna across the table to the columns for the lightning arrestors and cables you wrote down to confirm that they compatible with the antenna you've chosen and determine if an adaptor is required to connect the two selected parts.

2.1 FCC Compliance

Motorola Solutions enterprise Access Points are approved by the FCC with the understanding that these devices are Professionally Installed. Under FCC regulations, this allows the Professional Installers the flexibility to configure the Access Points for each specific customers needs and insure a compliant installation. The antennas offered in our portfolio have different coverage patterns and antenna gains to meet the needs of different installation requirements and require careful planning. The Access Point transmitter power must be adjusted by the professional installer based on the specific antenna and other installation components used in the installation to ensure compliant operation.

A professional installer must:

- Have a good understanding of RF theory
- Be able to calculate a link budget for a given transmitter configuration. For example, Conducted Output Power + Cabling Losses + Mechanical Connection Losses + Antenna Gain = Output Power (This output power should be equal or lower than the Maximum Power as listed on the FCC Grant for a transmitter)
- Be familiar with both the mechanical and software tools required to configure and adjust the transmitter being installed
- Understand basic FCC regulations for the site specific location and installation requirements of the various radio products being installed
- Understand basic antenna operational theory and standard industry antenna installation practices
- Be certified by local authorities to install electrical devices.



WARNING! OPERATING A TRANSMITTER THAT IS CONFIGURED FOR INDOOR USE IN AN OUTDOOR ENVIRONMENT IS AGAINST FCC REGULATIONS AND SUBJECT TO FCC ENFORCEMENT ACTIONS AGAINST BOTH THE INSTALLER AND THE OPERATOR.

2.1.1 Outdoor Access Point Installations

The FCC regulations for the indoor and outdoor installation are different; the professional installer must configure the Access Point transmitters accordingly. Products that are specifically intended to be placed outdoors are configured at the factory for compliant outdoor operation. Motorola Solutions recommends professional installers review the following to assess the legality of outdoor deployments:

- If a transmitter is placed indoors but the antenna is placed outdoors, the FCC interprets this as an outdoor installation
- If a transmitter is placed indoors and the antenna is oriented to intentionally radiate outdoors, the FCC interprets this as an outdoor installation
- If the transmitter is placed on a loading dock or inside a covered stadium with a retractable cover, the FCC views this as an outdoor installation

The *Federal Communications Commission* (FCC), the *National Telecommunications and Information Administration* (NTIA) and the *Federal Aviation Administration* (FAA) have an ongoing investigation of interference caused to *Terminal Doppler Weather Radar* (TDWR) systems operating in the 5600-5650 MHz band. TDWRs are used to detect wind shear and other weather conditions near airports.

The interference at most locations was attributed to fixed wireless transmitters operating outdoors in the vicinity of airports at high elevations that are line-of-sight to the TDWR installations (5 GHz network equipment).

In some instances, the interference was caused by equipment that was not properly certified or configured. In other instances, equipment was FCC certified nonetheless caused interference. The FCC has taken appropriate enforcement action in each of these cases.

If everything is determined to be compliant - the FCC orders the interfering transmitter turned off or adjustments be made such that there is no more interference; any non-compliance determined is resolved with an enforcement action.

On 14 OCTOBER 2010 the FCC published the following notice that requests that devices operating in the 5.4 GHz band located near the appended list of airports register these devices. A voluntary WISPA sponsored database has been developed that allows operators and installers to register the location information of the UNII devices operating outdoors in the 5470 - 5725 MHz band within 35 km of any TDWR location.



NOTE: Motorola Solutions strongly encourages the voluntary registration of all outdoor installations at <http://www.spectrumbridge.com/udia/home.aspx>.

2.2 FCC Approval Statement

**Federal Communications Commission
Office of Engineering and Technology
Laboratory Division**

Interim Plans to Approve UNII Devices Operating in the 5470 - 5725 MHz Band with Radar Detection and DFS Capabilities

The FCC, NTIA, FAA and industry are working to resolve interference to Terminal Doppler Weather Radar (TDWR) systems used near airports that has occurred from some outdoor wireless systems operating in the 5470 MHz – 5725 MHz band. These wireless devices are subject to Section 15.407 of our rules and when operating as a master device they are required to implement radar detection and DFS functions. We are continuing our work to develop long-term equipment authorization test procedures that will ensure that the devices comply with our rules that include protecting the TDWR operations. In the interim, the Commission will now allow certification of wireless master devices with radar detection function and with DFS capability, if they meet the following conditions:

- Devices will not transmit on channels which overlap the 5600 – 5650 MHz band.¹
- Devices intended for outdoor use will be further restricted, as follows:
 - Devices must be professionally installed when operating in the 5470 – 5725 MHz band.²
 - Grantees must provide owners, operators and all such installers with specific instructions in their user's manual on requirements to avoid interference to TDWRs and information that meets the following instructions:
 - Any installation of either a master or a client device within 35 km of a TDWR location shall be separated by at least 30 MHz (center-to-center) from the TDWR operating frequency (as shown in the attached table)^{3, 4, and 5}.

¹ The devices subject to the requirements in this KDB can select the initial channel for operation to avoid TDWRs and apply the Uniform Channel Spreading requirements (see FCC 06-96 in ET Docket 03-122 released June 30, 2006) on the remaining available frequency band of operation. All the other test procedures including the test radar patterns remain the same at the present time. A revision to the measurement procedure with modification to the Uniform Channel Spreading requirement and other changes will be released in the future. The Commission will also address the issue of any field upgrade option at that time.

² The grantee must identify the specific expertise and the training required by the installers for installing these types of devices.

³ In some instances it is possible that a device may be within 35 km of multiple TDWRs. In this case the device must ensure that it avoids operation within 30 MHz for each of the TDWRs. This requirement applies even if the master is outside the 35 km radius but communicates with outdoor clients which may be within the 35 km radius of the TDWRs.

⁴ The requirement for ensuring 30 MHz frequency separation is based on the best information available to date. If interference is not eliminated, a distance limitation based on line-of-sight from TDWR will need to be used. In addition, devices with bandwidths greater than 20 MHz may require greater frequency separation.

- Procedures for the installers and the operators on how to register the devices in the industry-sponsored database with the appropriate information regarding the location and operation of the device and installer information is included.⁶
- Devices must meet all of the other requirements specified in Section 15.407, and it is prohibited to include configuration controls (e.g. country code settings or other options to modify DFS functions) to change the frequency of operations to any frequency other than those specified on the grant of certification for US operation.⁷

- All applications for equipment authorization must clearly show compliance with all of the technical requirements under worst case parameters, under user or operator control, based on frame rates, listen/talk ratios and user data transfer conditions.

All the devices subject to the DFS requirements must be submitted to the Commission's Laboratory Division for pre-grant testing and equipment authorization.⁸ The applicant must ensure that all equipment authorization applications subject to this interim procedure include appropriate attestations that the device has no option to change the DFS parameters and that transmissions are disabled at least in the 5600 – 5650 MHz band. The application must include the user's manual with the appropriate installation and operations requirements for the installers and operators.

We are continuing to evaluate additional measures that may need to be taken to further ensure against interference caused by 5 GHz outdoor wireless systems located near airports. While manufacturers have an obligation to ensure that their equipment complies with FCC rules, and must take steps to ensure their devices are unlikely to cause harmful interference, Section 15.5 of the Commission's rules also places an obligation on users of devices to avoid causing interference and to correct any interference that may occur. We encourage the manufacturers to include information for the users, including the operators and installers, to ensure that they understand that it is incumbent on them to cooperate with manufacturers to implement any changes necessary to facilitate compliance.

⁵ Devices may be optionally designed not to transmit on channels which overlap 5570 – 5680 MHz instead of requiring installers to perform site-by-site adjustments. In that case it is still required that the devices should be installed professionally and the procedures for registering the device in the industry database should be included in the Users Manual.

⁶ A voluntary WISPA sponsored database has been developed that allows operators and installers to register the location information of the UNII devices operating outdoors in the 5470 – 5725 MHz band within 35 km of any TDWR location (see <http://www.spectrumbridge.com/udia/home.aspx>). This database may be used by government agencies in order to expedite resolution of any interference to TDWRs.

⁷ For example, device software must not have any country code options or software configuration settings which allow an end user to modify the DFS operation or impact the performance of DFS. See KDB 594280.

⁸ The TCBs are not permitted to approve transmitters with radar detection capabilities. See KDB 628591.

⁹ The manufacturers may consider taking steps providing clear instructions to operators and installers of devices as to the need to comply with rules for use of the band, guidance on registration of devices and any other processes that are designed to avoid interference. They may use methods that include, but are not limited to, instructions in manuals, notification on product web pages and service bulletins issued for products in the field.

TDWR Location Information*

STATE	CITY	LONGITUDE	LATITUDE	FREQUENCY	TERRAIN ELEVATION (MSL) [ft]	ANTENNA HEIGHT ABOVE TERRAIN [ft]
AZ	PHOENIX	W 112 09 46	N 33 25 14	5610 MHz	1024	64
CO	DENVER	W 104 31 35	N 39 43 39	5615 MHz	5643	64
FL	FT LAUDERDALE	W 080 20 39	N 26 08 36	5645 MHz	7	113
FL	MIAMI	W 080 29 28	N 25 45 27	5605 MHz	10	113
FL	ORLANDO	W 081 19 33	N 28 20 37	5640 MHz	72	97
FL	TAMPA	W 082 31 04	N 27 51 35	5620 MHz	14	80
FL	WEST PALM BEACH	W 080 16 23	N 26 41 17	5615 MHz	20	113

STATE	CITY	LONGITUDE	LATITUDE	FREQUENCY	TERRAIN ELEVATION (MSL) [ft]	ANTENNA HEIGHT ABOVE TERRAIN [ft]
GS	ATLANTA	W 084 15 44	N 33 38 48	5615 MHz	962	113
IL	MCCOOK	W 087 51 31	N 41 47 50	5615 MHz	646	97
IL	CRESTWOOD	W 087 43 47	N 41 39 05	5645 MHz	663	113
IN	INDIANAPOLIS	W 086 26 08	N 39 38 14	5605 MHz	751	97
KS	WICHITA	W 097 26 13	N 37 30 26	5603 MHz	1270	80
KY	COVINGTON CINNCINNATI	W 084 34 48	N 38 53 53	5610 MHz	942	97
KY	LOUISVILLE	W 085 36 38	N 38 02 45	5646 MHz	617	113
LA	NEW ORLEANS	W 090 24 11	N 30 01 18	5645 MHz	2	97
MA	BOSTON	W 070 56 01	N 42 09 30	5610 MHz	151	113
MD	BRANYWINE	W 076 50 42	N 38 41 43	5635 MHz	233	113
MD	BENFIELD	W 076 37 48	N 39 05 23	5645 MHz	184	113
MD	CLINTON	W 076 57 43	N 38 45 32	5615 MHz	249	97
MI	DETROIT	W 083 30 54	N 42 06 40	5615 MHz	656	113
MN	MINNEAPOLIS	W 092 55 58	N 44 52 17	5610 MHz	1040	80
MO	KANSAS CITY	W 094 44 31	N 39 29 55	5605 MHz	1040	64
MO	SAINT LOUIS	W 090 29 21	N 38 48 20	5610 MHz	551	97
MS	DESOTO COUNTY	W 089 59 33	N 34 53 45	5610 MHz	371	113
NC	CHARLOTTE	W 080 53 06	N 35 20 14	5608 MHz	757	113
NC	RALEIGH DURHAM	W 078 41 50	N 36 00 07	5647 MHz	400	113
NJ	WOODBIDGE	W 074 16 13	N 40 35 37	5620 MHz	19	113
NJ	PENNSAUKEN	W 075 04 12	N 39 56 57	5610 MHz	39	113
NV	LAS VEGAS	W 115 00 26	N 36 08 37	5645 MHz	1995	64
NY	FLOYD BENNETT FIELD	W 073 52 49	N 40 35 20	5647 MHz	8	97
OH	DAYTON	W 084 07 23	N 40 01 19	5640 MHz	922	97
OH	CLEVELAND	W 082 00 28	N 41 17 23	5645 MHz	817	113
OH	COLUMBUS	W 082 42 55	N 40 00 20	5605 MHz	1037	113
OK	AERO. CTR TDWR #1	W 097 37 31	N 35 24 19	5610 MHz	1285	80

STATE	CITY	LONGITUDE	LATITUDE	FREQUENCY	TERRAIN ELEVATION (MSL) [ft]	ANTENNA HEIGHT ABOVE TERRAIN [ft]
OK	AERO. CTR TDWR #2	W 097 37 43	N 35 23 34	5620 MHz	1293	97
OK	TULSA	W 095 49 34	N 36 04 14	5605 MHz	712	113
OK	OKLAHOMA CITY	W 097 30 36	N 35 16 34	5603 MHz	1195	64
PA	HANOVER	W 080 29 10	N 40 30 05	5615 MHz	1266	113
PR	SAN JUAN	W 066 10 46	N 18 28 26	5610 MHz	59	113
TN	NASHVILLE	W 086 39 42	N 35 58 47	5605 MHz	722	97
TX	HOUSTON INTERCONTL	W 095 34 01	N 30 03 54	5605 MHz	154	97
TX	PEARLAND	W 095 14 30	N 29 30 59	5645 MHz	36	80
TX	DALLAS LOVE FIELD	W 096 58 06	N 32 55 33	5608 MHz	541	80
TX	LEWISVILLE DFW	W 096 55 05	N 33 03 53	5640 MHz	554	31
UT	SALT LAKE CITY	W 111 55 47	N 40 58 02	5610 MHz	4219	80
VA	LEESBURG	W 077 31 46	N 39 05 02	5605 MHz	361	113
WI	MILWAUKEE	W 088 02 47	N 42 49 10	5603 MHz	820	113

2.3 FCC USA Compaibility Matrix

The following (on the next two pages) displays Motorola Solutions FCC approved AP radio, antenna, cable and accessory combinations for use in the United States for both current and legacy access points:

		AP Radios								Cables					LAs				
		AP-7131 ABGN (U57AP7131)	AP-7131N ABGN (U77AP7131N)	AP-650 (U77MB82)	AP-6532 ABGN (U77MB82)	AP-621 (U77AP6)	AP-6521 (U77AP6)	AP-7161 (QJ7AP716101)	AP-622 (U77AP0622)	AP-8132 (U77KHP800)	ML-1499-100JK-01R	ML-1499-10JK-01R	ML-1499-25JK-01R	ML-1499-50JK-01R	ML-1499-72PJ-01R	ML-1499-LAK1-01R	ML-1499-LAK2-01R	ML-2452-LAK1-01R	
Antennas	2.4 GHz	ML-2499-11PNA2-01R	3	3	3	3	X	X	X	3	3	1	1	1	1	*	2	2	2
		ML-2499-11PNA2-02R	X	X	X	X	X	X	X	*	*	4	4	4	4	X	5	5	5
		ML-2499-5PNL-72-N	7	7	X	X	X	X	X	7	7	A	A	A	A	X	*	*	*
		ML-2499-7PNA2-01R	3	3	X	X	X	X	X	3	7	1	1	1	1	*	2	2	2
		ML-2499-7PNA2-02R	*	*	*	*	X	X	X	*	*	4	4	4	4	X	5	5	5
		ML-2499-APA2-01R	3	3	3	3	3	3	X	3	3	X	X	X	X	X	X	X	X
		ML-2499-APA2-02R	*	*	*	*	*	*	X	*	*	4	4	4	4	X	5	5	5
		ML-2499-BPNA3-01R	6	6	X	X	X	X	X	6	6	*	*	*	*	X	X	*	X
		ML-2499-BYGA2-01R	6	6	X	X	X	X	X	6	6	*	*	*	*	X	X	*	X
		ML-2499-FHPA5-01R	7	7	7	7	X	X	*	7	7	A	A	A	A	X	*	*	*
	ML-2499-FHPA9-01R	7	7	7	7	X	X	X	7	7	A	A	A	A	X	*	*	*	
	ML-2499-HPA3-01R	3	3	3	3	3	3	2	3	3	1	1	1	1	*	2	2	2	
	ML-2499-HPA3-02R	X	X	*	*	*	*	5	*	*	4	4	4	4	X	5	5	5	
	ML-2499-HPA4-01	X	7	7	7	7	7	*	7	7	A	A	A	A	X	*	*	*	
	ML-2499-HPA8-01	X	X	7	7	X	X	*	7	7	A	A	A	A	X	*	*	*	
	ML-2499-PNAHD-01R	3	3	X	X	X	X	3	3	3	1	1	1	1	*	2	2	2	
	ML-2499-PNAHD-02R	*	*	*	*	X	X	X	*	*	4	4	4	4	X	5	5	5	
	ML-2499-SD3-01R	3	3	3	3	3	3	X	3	3	1	1	1	1	*	2	2	2	
	ML-2499-SD3-02R	X	*	*	*	*	*	X	*	*	4	4	4	4	X	5	5	5	
	5 GHz	ML-5299-APA1-01R	*	*	*	*	*	X	*	*	X	X	X	X	X	X	X	X	X
ML-5299-BYGA15-012		X	6	X	X	X	X	6	6	*	*	*	*	X	X	*	X		
ML-5299-FHPA10-01R		X	X	7	7	X	X	*	X	7	A	A	A	A	X	*	*	*	
ML-5299-FHPA6-01R		7	7	7	7	X	X	*	7	7	A	A	A	A	X	*	*	*	
ML-5299-HPA1-01R		*	*	*	*	*	*	5	*	*	4	4	4	4	X	5	5	5	
ML-5299-HPA5-01		X	7	7	7	7	7	*	7	7	A	A	A	A	X	*	*	*	
ML-5299-HPA10-01		X	X	7	7	X	X	*	X	7	A	A	A	A	X	*	*	*	
ML-5299-PTA1-01R		*	*	*	*	*	*	X	*	*	4	4	4	4	X	5	5	5	
ML-5299-WPNA1-01R		*	*	X	X	X	X	X	*	*	4	4	4	4	X	5	5	5	
Dual-Band		ML-2452-APA2-01	*	*	*	*	*	X	*	*	X	X	X	X	X	X	X	X	X
	ML-2452-APA2-02	*	*	*	*	*	X	*	*	X	X	X	X	X	X	X	X	X	
	ML-2452-APAG2A1-01	X	X	X	X	*	*	X	*	*									
	ML-2452-APAG2A1-02	X	X	X	X	*	*	X	*	*									
	ML-2452-HPA5-036	*	*	*	*	*	*	*	*	*									
	ML-2452-HPA6X6-036	X	7	7	7	7	7	*	7	7	A	A	A	A	X	*	*	*	
	ML-2452-HPAG4A6-01	X	X	*	*	*	*	*	7	7	A	A	A	A	X	*	*	*	
	ML-2452-HPAG5A8-01	X	X	*	*	X	X	*	7	7	A	A	A	A	X	*	*	*	
	ML-2452-PNA5-01R	7	7	7	7	7	7	X	7	7	A	A	A	A	X				
	ML-2452-PNA7-01R	7	7	X	X	X	X	X	7	7	A	A	A	A	X				
	ML-2452-PNL9M3-036	*	*	X	X	X	X	X	*	*									
	ML-2452-PTA2M2-036	X	*	*	*	*	*	X	*	X	4	4	4	4	X	5	5	5	
	ML-2452-PTA2M3X3-1	*	*	X	X	X	X	X	X	X									
	ML-2452-PTA3M3-036	*	*	*	*	*	*	X	X	X									
ML-2452-PTA6X6-036	*	*	*	*	*	*	X	*	X	4	4	4	4	X	5	5	5		
LAs	ML-1499-LAK1-01R	X	X	X	X	X	X	X	X	*	*	*	*	X	*	*	*		
	ML-1499-LAK2-01R	X	X	X	X	X	X	*	X	X	*	*	*	X	*	*	*		
	ML-2452-LAK1-01R	*	*	*	*	*	*	X	*	*	*	*	*	X	*	*	*		
Cables	ML-1499-100JK-01R	7	7	7	7	7	7	*	7	7									
	ML-1499-10JK-01R	7	7	7	7	7	7	*	7	7									
	ML-1499-25JK-01R	7	7	7	7	7	7	*	7	7									
	ML-1499-50JK-01R	7	7	7	7	7	7	*	7	7									
	ML-1499-72PJ-01R	X	X	X	X	X	X	X	X	X									

Key	Adapter P/N	Adapter Description
1	ML-1499-RBNCA1-01R	RP-BNC-F to N-F
2	ML-1499-RBNCA2-01R	RP-BNC-F to N-M
3	25-72178-01	RP-SMA-M to RP-BNCF
4	25-90262-01R	RP-SMA-F to N-F
5	25-90263-01R	N-M to RP-SMA-F
6	25-85391-01R	RP-SMA-M to N-M
7	25-85392-01R	RP-SMA-M to N-F
8	must use ML-1499-LAK1-01R	
9	25-97261-01R	NM to RP-BNC-M
A	25-99175-01R	NF to NF

Key	Description
*	Compatible
X	Not compatible
	Not required

		AP Radios				Cables					LAs				
		AP300 (H9PWSAP5100)	AP300 B/G (H9PWSAP5200bg)	AP-5131 (H9PA5131)	AP-5181 (H9PA5181)	ML-1499-100JK-01R	ML-1499-10JK-01R	ML-1499-25JK-01R	ML-1499-50JK-01R	ML-1499-72PJ-01R	ML-1499-LAK1-01R	ML-1499-LAK2-01R	ML-2452-LAK1-01R		
Antennas	2.4 GHz	ML-2499-11PNA2-01R	*	*	3	X	1	1	1	1	*	2	2	2	
		ML-2499-5PNL-72-N	8	8	*	X	A	A	A	A	X	*	*	*	
		ML-2499-7PNA2-01R	*	*	3	X	1	1	1	1	*	2	2	2	
		ML-2499-APA2-01	*	*	X	X	X	X	X	X	X	X	X	X	X
		ML-2499-BPNA3-01R	9	9	X	X	*	*	*	*	X	X	*	X	
		ML-2499-BYGA2-01R	9	9	6	X	*	*	*	*	X	X	*	X	
		ML-2499-FHPA5-01R	8	8	9	*	A	A	A	A	X				
		ML-2499-FHPA9-01R	8	8	X	*	A	A	A	A	X				
		ML-2499-HPA3-01R	*	*	3	X	1	1	1	1	*	2	2	2	
		ML-2499-PNAHD-01R	*	*	3	X	1	1	1	1	*	2	2	2	
	ML-2499-SD3-01R	*	*	X	X	1	1	1	1	*	2	2	2		
	5 GHz	ML-5299-APA1-01R	*	X	*	X	X	X	X	X	X	X	X	X	
		ML-5299-BYGA15-012	X	X	X	X	*	*	*	*	X				
		ML-5299-FHPA10-01R	X	X	X	*	A	A	A	A	X				
		ML-5299-FHPA6-01R	X	X	X	*	A	A	A	A	X				
		ML-5299-HPA1-01R	*	X	*	X	4	4	4	4	X	5	5	5	
		ML-5299-PTA1-01R	*	X	X	X	4	4	4	4	X	5	5	5	
		ML-5299-WPNA1-01R	*	X	*	X	4	4	4	4	X	5	5	5	
	Dual	ML-2452-APA2-01	*	*	*	X	X	X	X	X	X	X	X	X	
		ML-2452-APA2-02	*	*	*	X	X	X	X	X	X	X	X	X	
		ML-2452-PNA5-01R	*	*	X	*	A	A	A	A	X				
		ML-2452-PNA7-01R	X	X	X	*	A	A	A	A	X				
		ML-2452-PTA2M3X3-1	X	X	X	X									
		ML-2452-PTA3M3-036	X	X	X	X									
		ML-2452-HPA5-036	X	X	X	X									
		ML-2452-PNL9M3-036	X	X	X	X									
		ML-2452-APA6J-01	X	X	X	X									
		ML-2452-APAG2A1-01	X	X	X	X									
	ML-2452-APAG2A1-02	X	X	X	X										

LAs	ML-1499-LAK1-01R	ML-1499-LAK2-01R	ML-2452-LAK1-01R
	X	*	X
	X	X	X
	*	X	*

*	*	*	*	X
*	*	*	*	X
*	*	*	*	X

Cables	ML-1499-100JK-01R	ML-1499-10JK-01R	ML-1499-25JK-01R	ML-1499-50JK-01R	ML-1499-72PJ-01R
	7	X	7	*	
	7	X	7	*	
	7	X	7	*	
	7	X	7	*	
	*	*	X	X	

Key	Adapter P/N	Adapter Description
1	ML-1499-RBNCA1-01R	RP-BNC-F to N-F
2	ML-1499-RBNCA2-01R	RP-BNC-F to N-M
3	25-72178-01	RP-SMA-M to RP-BNCF
4	25-90262-01R	RP-SMA-F to N-F
5	25-90263-01R	N-M to RP-SMA-F
6	25-85391-01R	RP-SMA-M to N-M
7	25-85392-01R	RP-SMA-M to N-F
8	must use ML-1499-LAK1-01R	
9	25-97261-01R	NM to RP-BNC-M
A	25-99175-01R	NF to NF

Key	Description
*	Compatible
X	Not compatible
	Not required

2.4 GHz Single Band Antenna Suite

3.1 Supported 802.11b/g/n Antenna Suite

Motorola Solutions supports numerous single-band 2.4 GHz 802.11b/g/n antennas to suit the requirements of your unique access point or access port deployment. Check the Motorola Solutions Web site periodically, as newly supported 802.11b/g/n antennas will be added to this document as they are released. For more information, go to <http://supportcentral.motorola.com/support/product/manuals.do>.

For detailed information on supported 802.11b/g/n antenna models, refer to:

- *ML-2499-5PNL-72-N Outdoor 135° Panel Antenna: Male Connector*
- *ML-2499-7PNA2-01R Indoor 60° Diversity Panel: RP-BNC Male*
- *ML-2499-7PNA2-02R Outdoor Panel Antenna: RP-SMA Male*
- *ML-2499-11PNA2-01R 97°Sector Panel: RP-BNC Male*
- *ML-2499-11PNA2-02R Sector Panel: RP-SMA Male*
- *ML-2499-APA2-01R Indoor Rubber Flex, Elbow Joint Dipole: RP-BNC Male*
- *ML-2499-APA2-02R Omnidirectional Dipole Antenna: RP-SMA Male*
- *ML-2499-BPNA3-01R Outdoor 35° High-Gain Directional Panel: Type N - Female*
- *ML-2499-BYGA2-01R Outdoor 35° High-Gain Directional Yagi: N Female*
- *ML-2499-HPA3-01R High Performance Omni-Directional "Pipe" Antenna: RP-BNC Male*
- *ML-2499-HPA3-02R Dipole Omni Antenna: RP-SMA Male*
- *ML-2499-PNAHD-01R Indoor 55°Directional Panel: RP-BNC Male*
- *ML-2499-PNAHD-02R Outdoor Patch Antenna: RP-SMA Male*
- *ML-2499-SD3-01R Low Profile Ceiling/Surface Mount Omni-Directional Patch: RP-BNC Male*
- *ML-2499-SD3-02R Patch Omni Antenna: RP-SMA Male*
- *ML-2499-FHPA5-01R Omni-Directional "Pipe" Antenna: N Male Connector*
- *ML-2499-FHPA9-01R High Performance Fixed Point Dipole: Male Connector*
- *ML-2499-HPA4-01 Outdoor Dipole Omni Antenna: N Male Connector*
- *ML-2499-HPA8-01 Outdoor Dipole Omni Antenna: N Male Connector*



NOTE: For examples on how various antenna and connectors are deployed in a 2.4 GHz AP-5131 installation, see [2.4 GHz AP-5131 Antenna Connections](#).

3.1.1 ML-2499-5PNL-72-N Outdoor 135° Panel Antenna: Male Connector

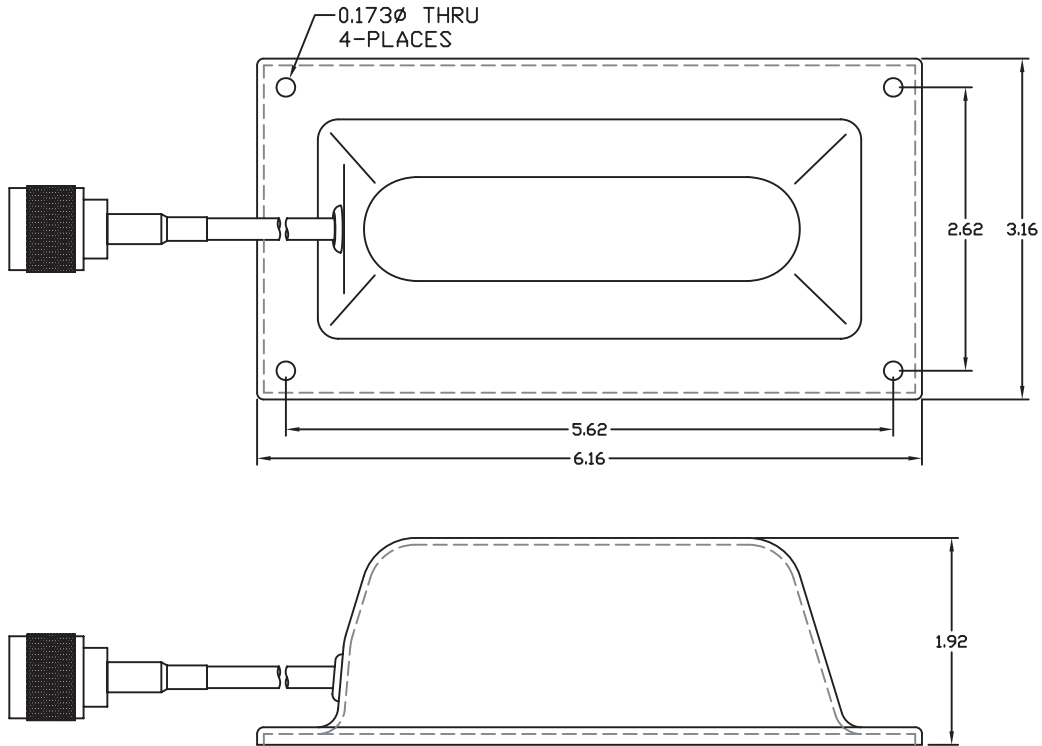

Type	Panel
Frequency	2400-2500 MHz
Gain (dBi)	6.5
Polarization	Linear, Vertical
Azimuth	3dB Beamwidth: 135°
Elevation	3dB Beamwidth: 55°
Cable Length (in.)	72
Cable Type	RG-58 Ultralink
Connector Type	Type N Male
Weight	0.25 lb.
Plenum Antenna	No
Plenum Cable	Yes
Outdoor Rated	Yes
Storage Temp Range (C)	-30 / +70
Operation Temp Range (C)	-30 / +70

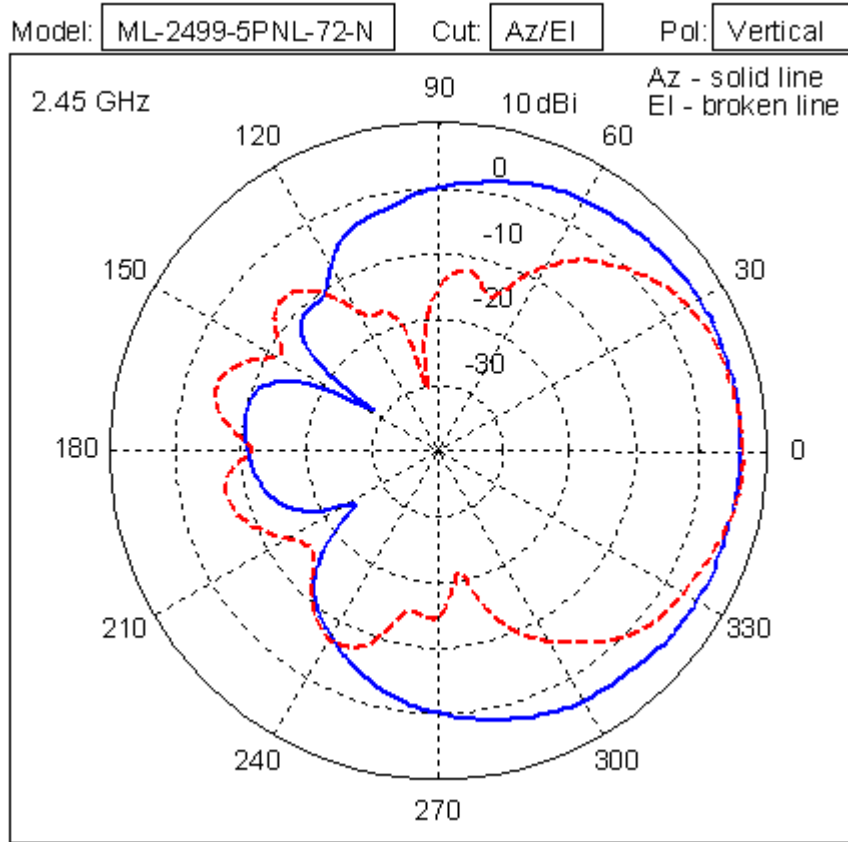

3.1.2 ML-2499-7PNA2-01R Indoor 60° Diversity Panel: RP-BNC Male

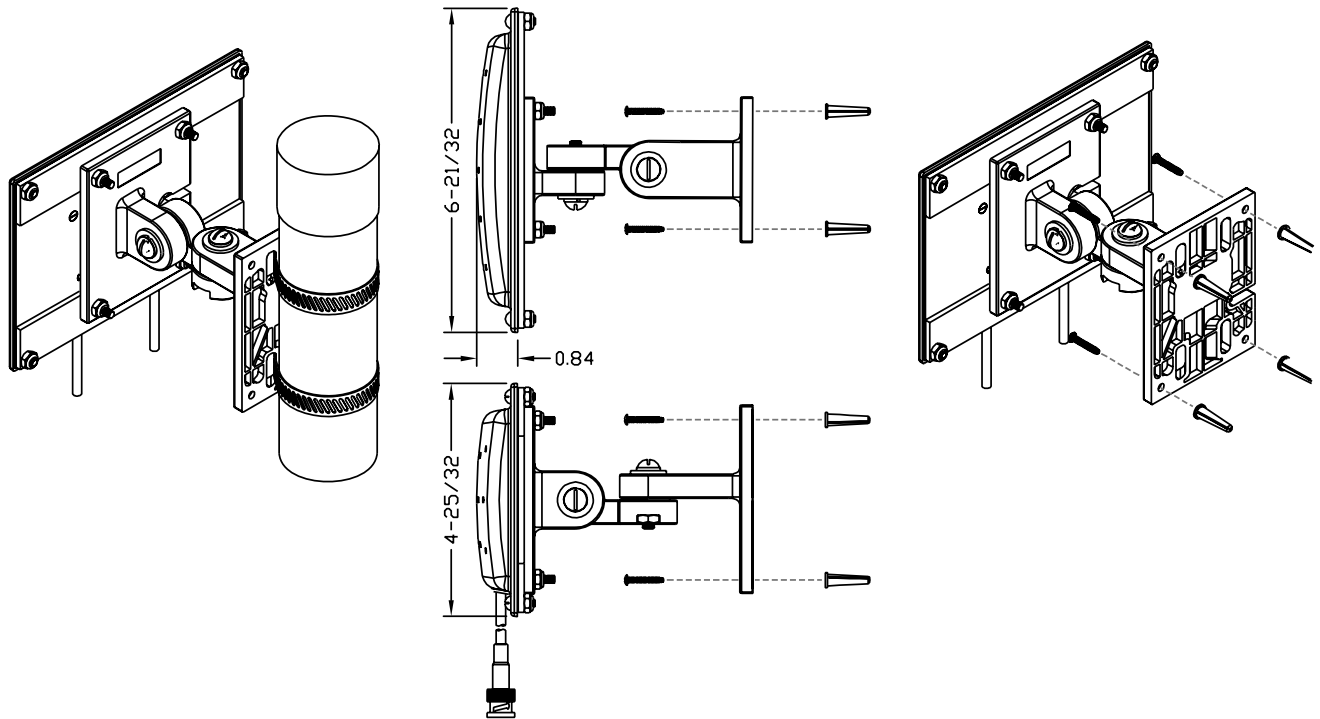

<i>Type</i>	Panel x 2 (Diversity)
<i>Frequency</i>	2400-2500 MHz
<i>Gain (dBi)</i>	6.5
<i>Polarization</i>	Linear, Vertical
<i>Azimuth</i>	3dB Beamwidth: 80°
<i>Elevation</i>	3dB Beamwidth: 55°
<i>Cable Length (in.)</i>	48
<i>Cable Type</i>	RG-58 Ultralink
<i>Connector Type</i>	RP-BNC Male x 2
<i>Weight</i>	0.6 lbs
<i>Plenum Antenna</i>	No
<i>Plenum Cable</i>	Yes
<i>Outdoor Rated</i>	No

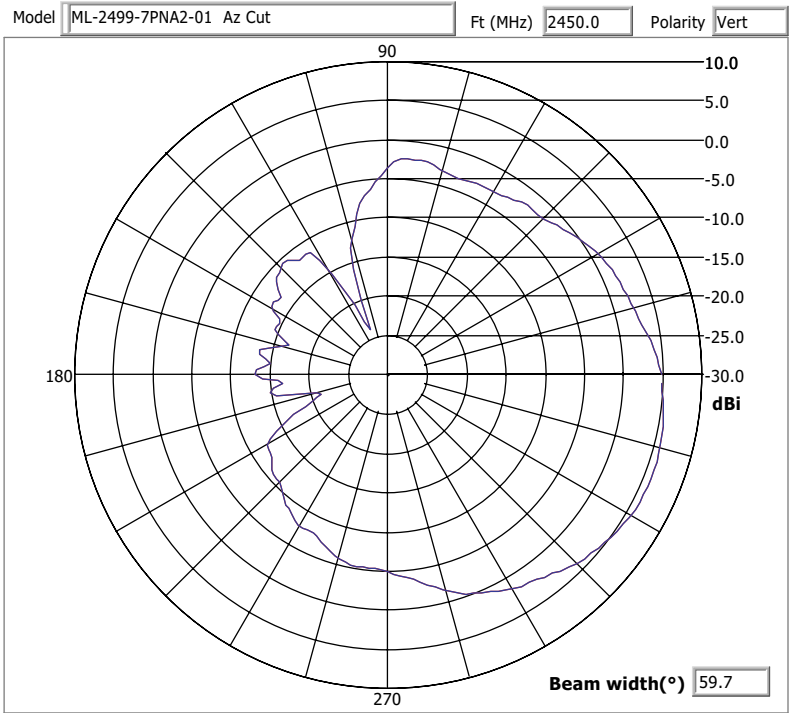

11/12/2003 2:50:29 PM

Azimuth Cut

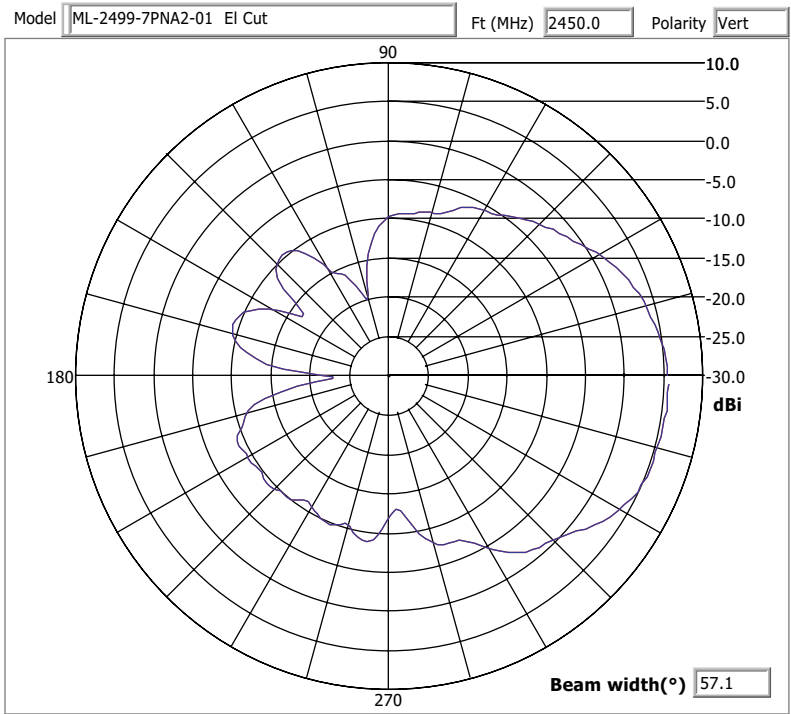

11/12/2003 2:53:26 PM

Elevation Cut

3.1.3 ML-2499-7PNA2-02R Outdoor Panel Antenna: RP-SMA Male

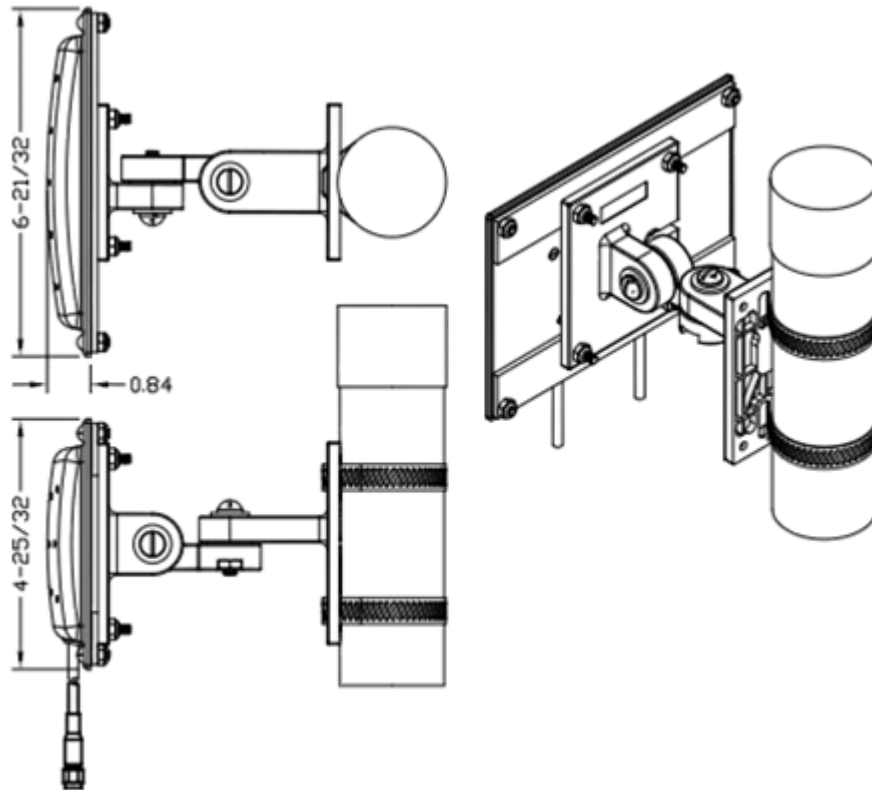

Type	Panel x 2 (Diversity)
Frequency	2400-2500 MHz
Gain (dBi)	7.5
Polarization	Linear, Vertical
Azimuth	3dB Beamwidth: 80°
Elevation	3dB Beamwidth: 55°
Cable Length (in.)	48
Cable Type	RG-58 Ultralink
Connector Type	RP-SMA Male x 2
Weight	0.5 lbs
Plenum Antenna	Yes
Plenum Cable	N/A
Outdoor Rated	Yes
Storage Temp Range (C)	-30 / +70
Operation Temp Range (C)	-30 / +70

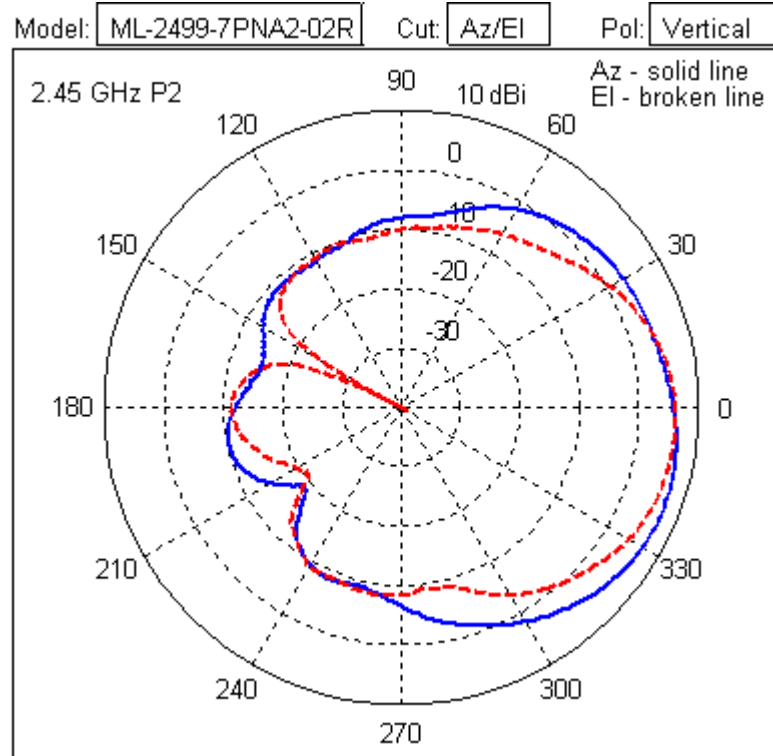
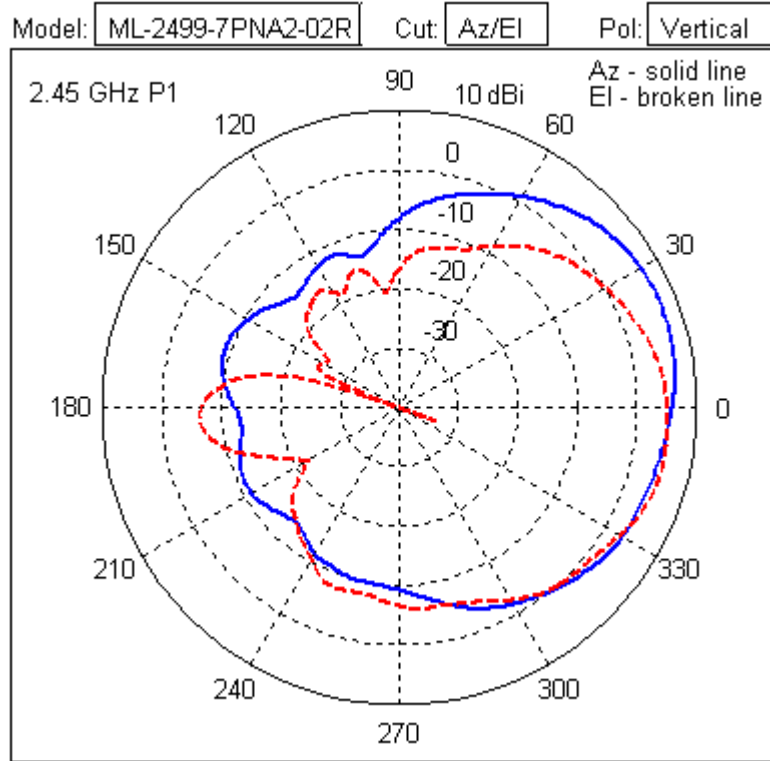

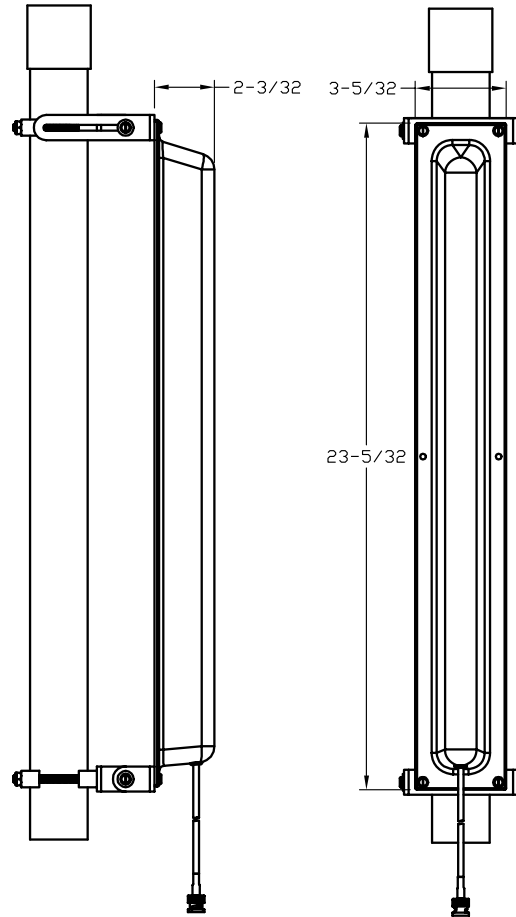
3.1.4 ML-2499-11PNA2-01R 97° Sector Panel: RP-BNC Male

<i>Type</i>	Panel
<i>Frequency</i>	2400-1500 MHz
<i>Gain (dBi)</i>	11
<i>Polarization</i>	Linear, Vertical
<i>Azimuth</i>	3dB Beamwidth: 120°
<i>Elevation</i>	3dB Beamwidth: 13°
<i>Cable Length (in.)</i>	96
<i>Cable Type</i>	RG-58 Ultralink
<i>Connector Type</i>	RP-BNC Male
<i>Weight</i>	1.5 lb
<i>Plenum Antenna</i>	No
<i>Plenum Cable</i>	Yes
<i>Outdoor Rated</i>	Yes

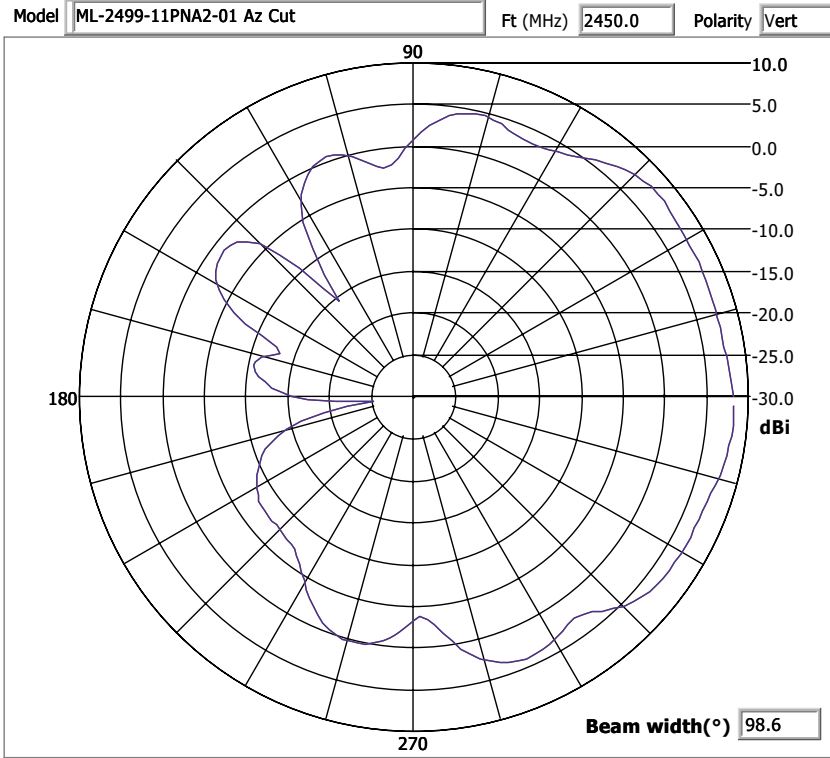

Azimuth Pattern

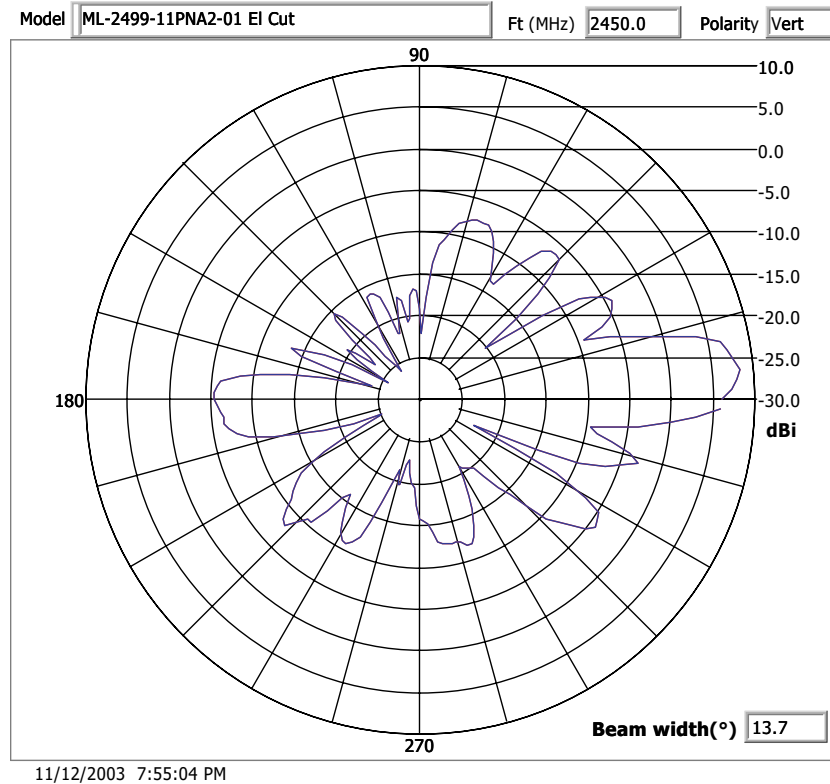

Elevation Pattern

3.1.5 ML-2499-11PNA2-02R Sector Panel: RP-SMA Male

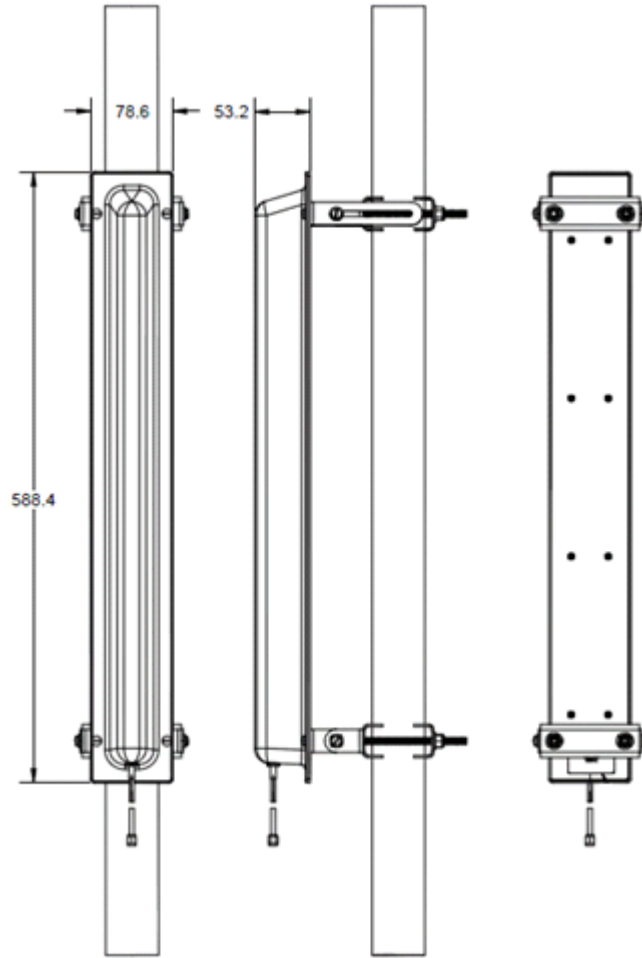

Type	Sector
Frequency	2400-1500 MHz
Gain (dBi)	12
Polarization	Linear, Vertical
Azimuth	3dB Beamwidth: 120°
Elevation	3dB Beamwidth: 13°
Cable Length (in.)	96
Cable Type	RG-58 Ultralink
Connector Type	RP-SMA Male
Weight	1.5 lb
Plenum Antenna	N/A
Plenum Cable	Yes
Outdoor Rated	Yes
Storage Temp Range (C)	-30 / +70
Operation Temp Range (C)	-30 / +70

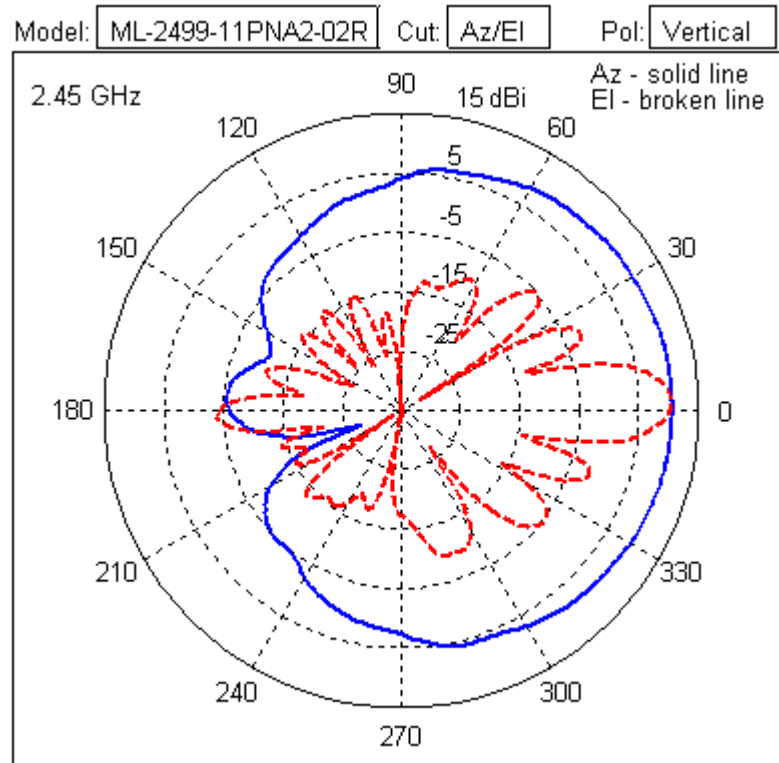

3.1.6 ML-2499-APA2-01R Indoor Rubber Flex, Elbow Joint Dipole: RP-BNC Male

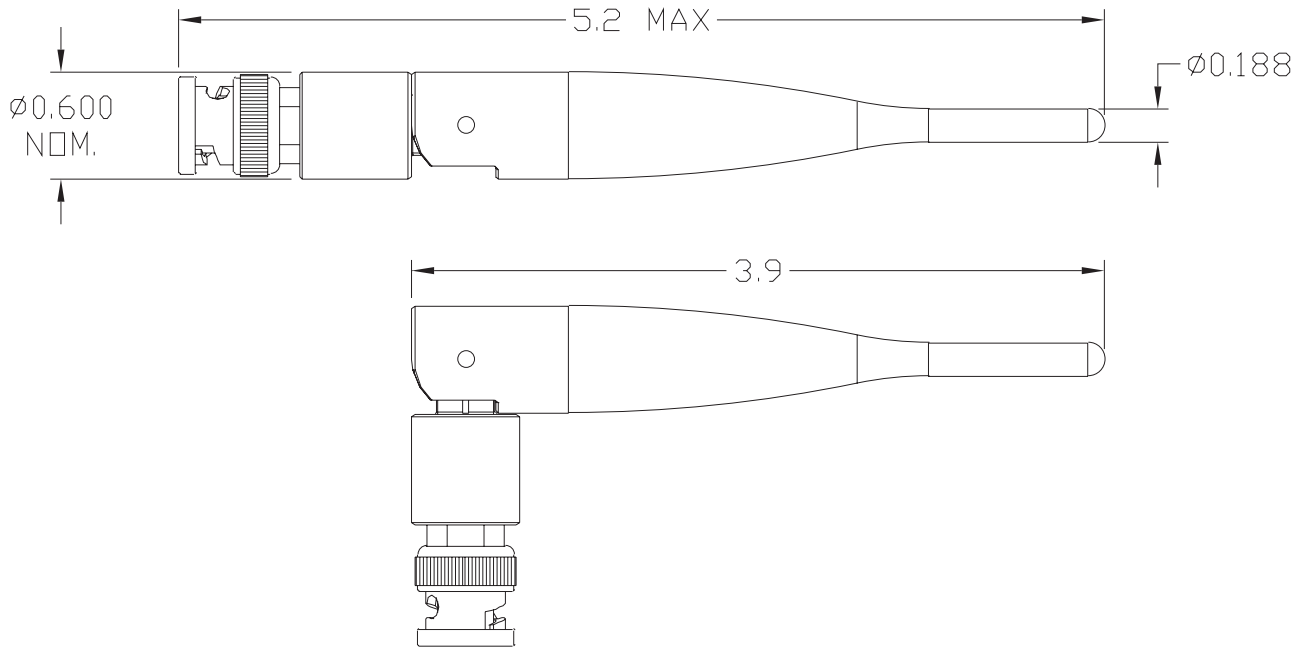

Type	Dipole
Frequency	2400-2500 MHz
Max/Typ Gain (dBi)	3.2/2.0
Polarization	Linear, Vertical
Azimuth	3dB Beamwidth: 360°
Elevation	3dB Beamwidth: 60°
Cable Length (in.)	0
Cable Type	N/A
Connector Type	RP-BNC Male
Weight	0.075 lbs
Plenum Antenna	No
Plenum Cable	N/A
Outdoor Rated	No

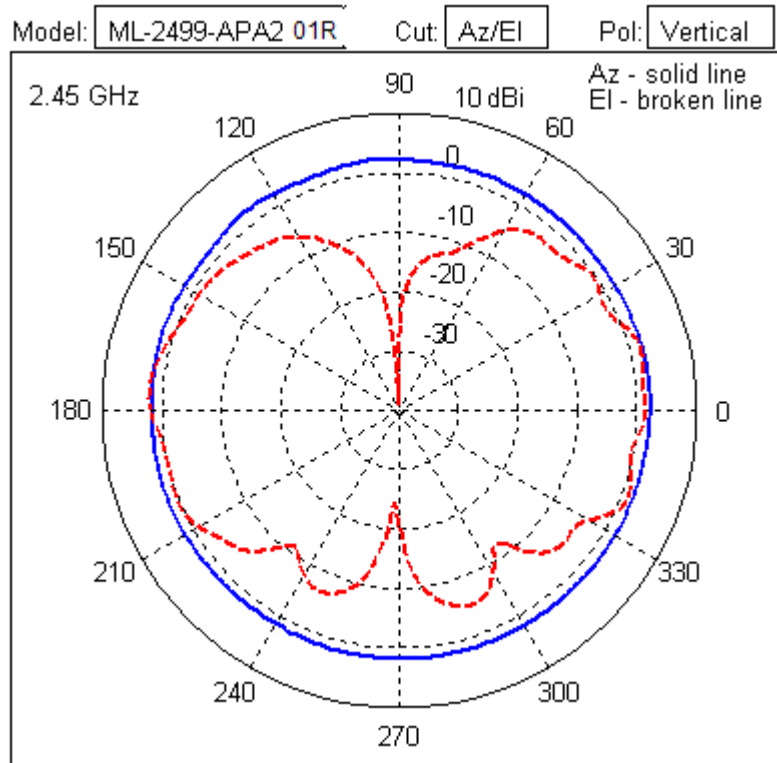

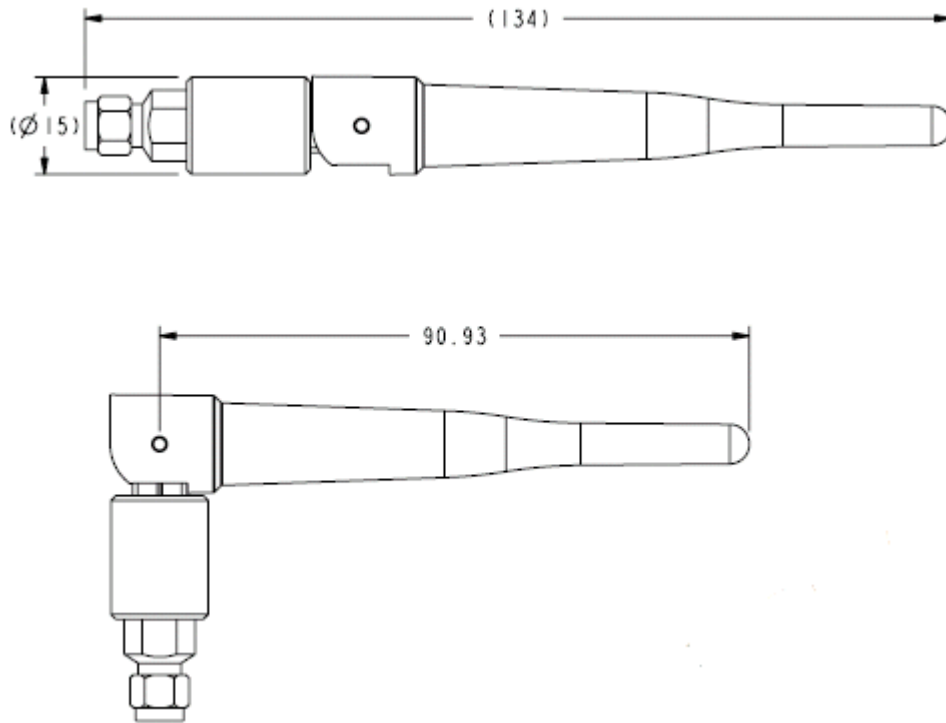
3.1.7 ML-2499-APA2-02R Omnidirectional Dipole Antenna: RP-SMA Male

Type	Dipole
Frequency	2400-2500 MHz
Gain (dBi)	2
Polarization	Linear, Vertical
Azimuth	3dB Beamwidth: 360°
Elevation	3dB Beamwidth: 80°
Cable Length (in.)	N/A
Cable Type	N/A
Connector Type	RP-BNC Male
Weight	0.075 lbs
Plenum Antenna	No
Plenum Cable	N/A
Outdoor Rated	No
Storage Temp Range (C)	-30 / +85
Operation Temp Range (C)	-20 / +75

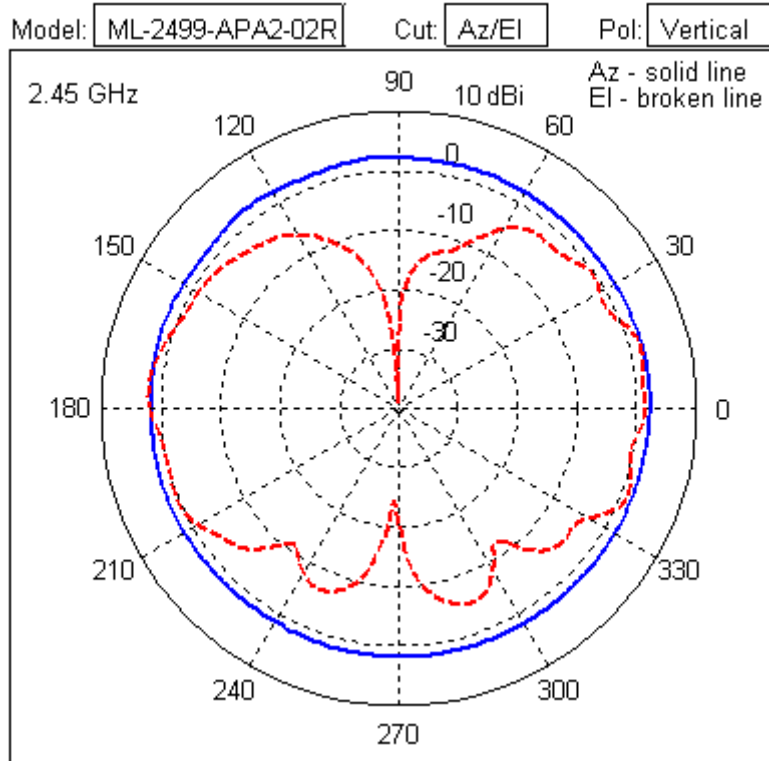

3.1.8 ML-2499-BPNA3-01R Outdoor 35° High-Gain Directional Panel: Type N - Female

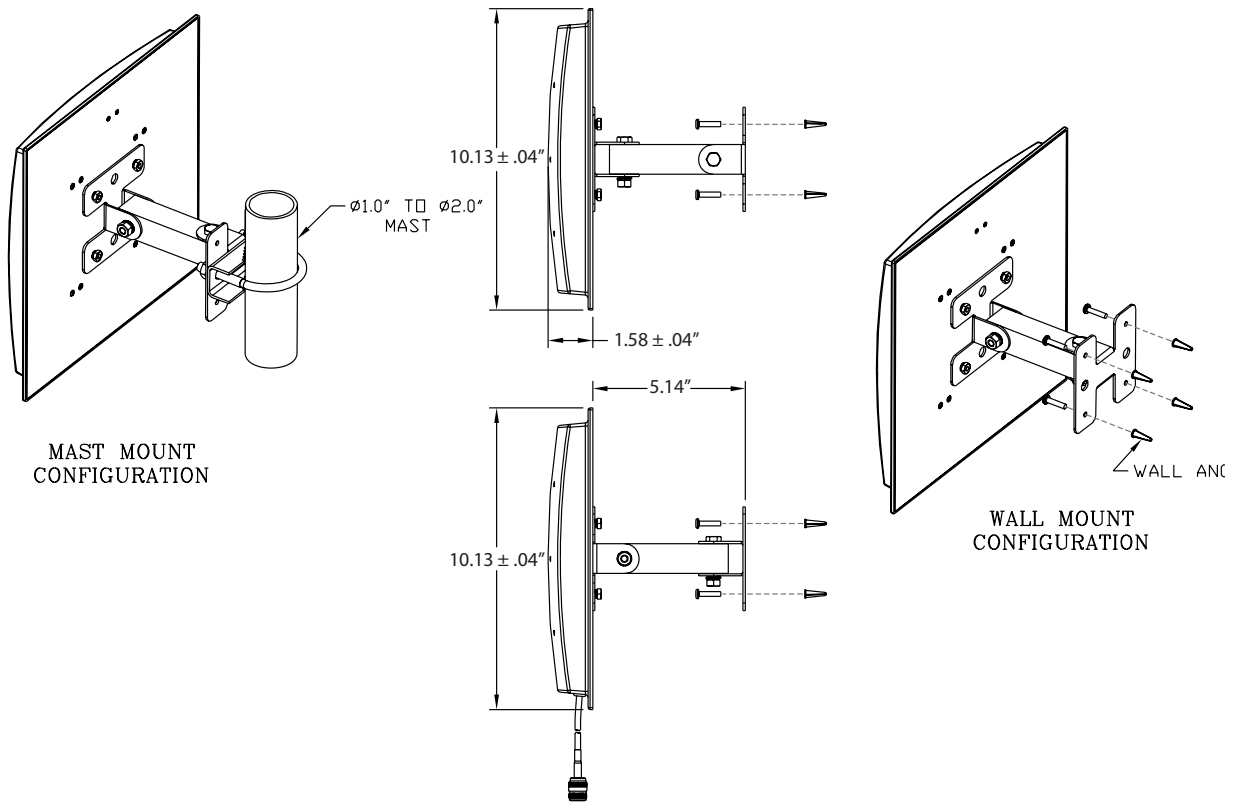

Type	Panel (Outdoor)
Frequency	2400-2500 MHz
Gain (dBi)	13.9
Net Gain (dBi)	10.9 (minimum cable configuration)
Cable Loss (dB)	3 (minimum cable configuration)
Polarization	Linear, Vertical
Azimuth	3dB Beamwidth: 35°
Elevation	3dB Beamwidth: 28°
Cable Length (in.)	Use minimum configuration (or more)
Cable Type	Varies per cable configuration
Connector Type	Type N Female
Weight	1.5 lb
Plenum Antenna	N/A
Plenum Cable	N/A
Outdoor Rated	Yes

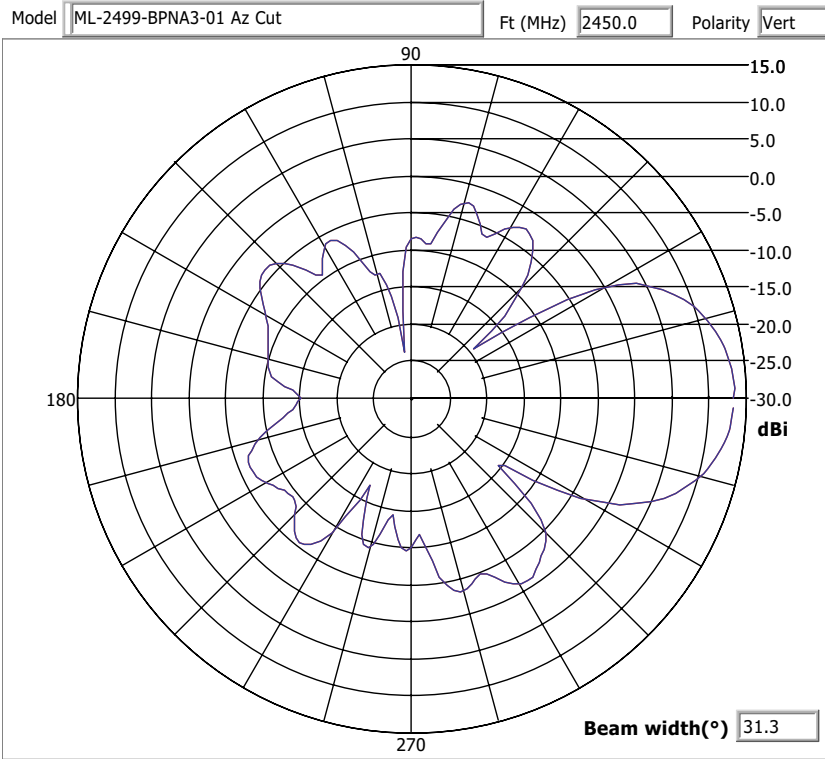

11/12/2003 4:49:00 PM

Azimuth Pattern

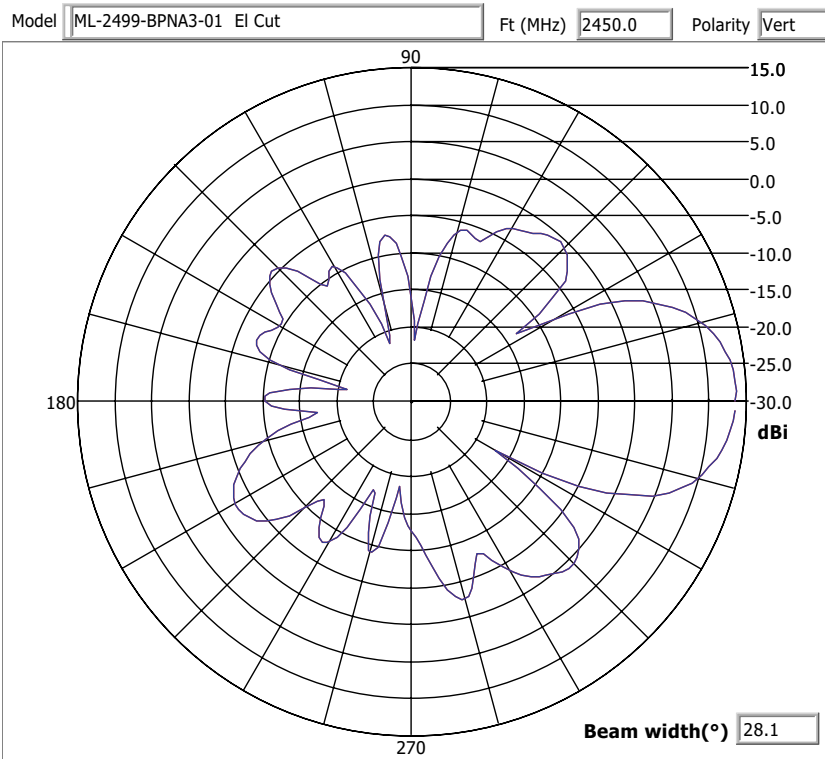

11/12/2003 4:44:40 PM

Elevation Pattern

3.1.9 ML-2499-BYGA2-01R Outdoor 35° High-Gain Directional Yagi: N Female

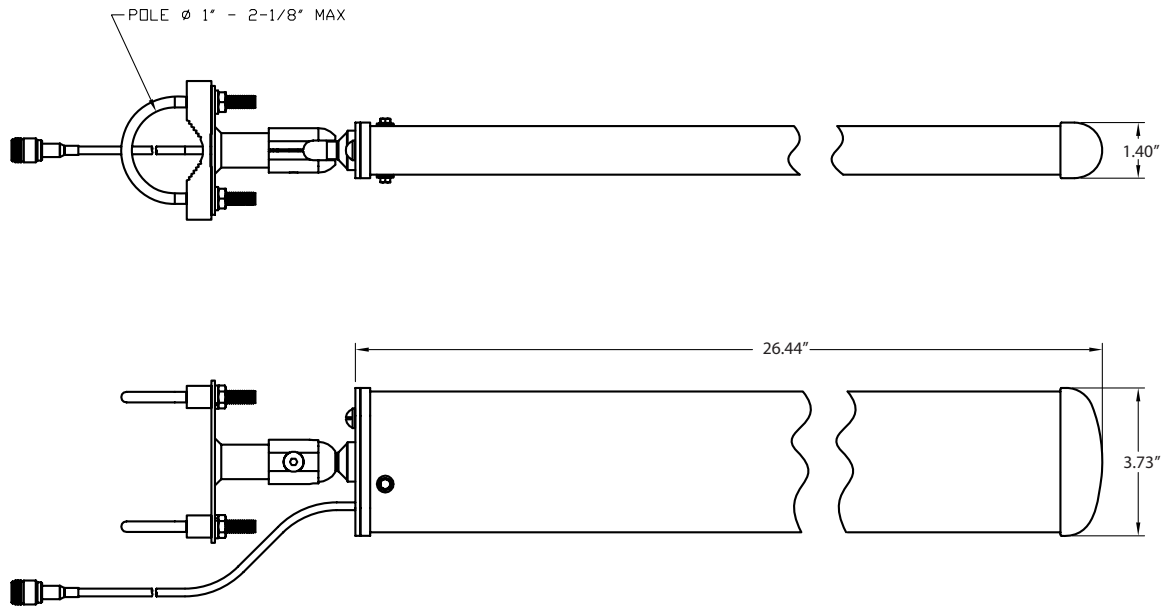

Type	Yagi (Outdoor)
Frequency	2400-2500 MHz
Gain (dBi)	14.5
Polarization	Linear, Vertical
Azimuth	3dB Beamwidth: 34°
Elevation	3dB Beamwidth: 30°
Cable Length (in.)	12
Cable Type	Varies per the cable configuration used
Connector Type	Type N - Female
Power	50 W
Weight	1.25 lbs
Storage Temp Range (C)	-30 / +70
Operation Temp Range (C)	-30 / +70

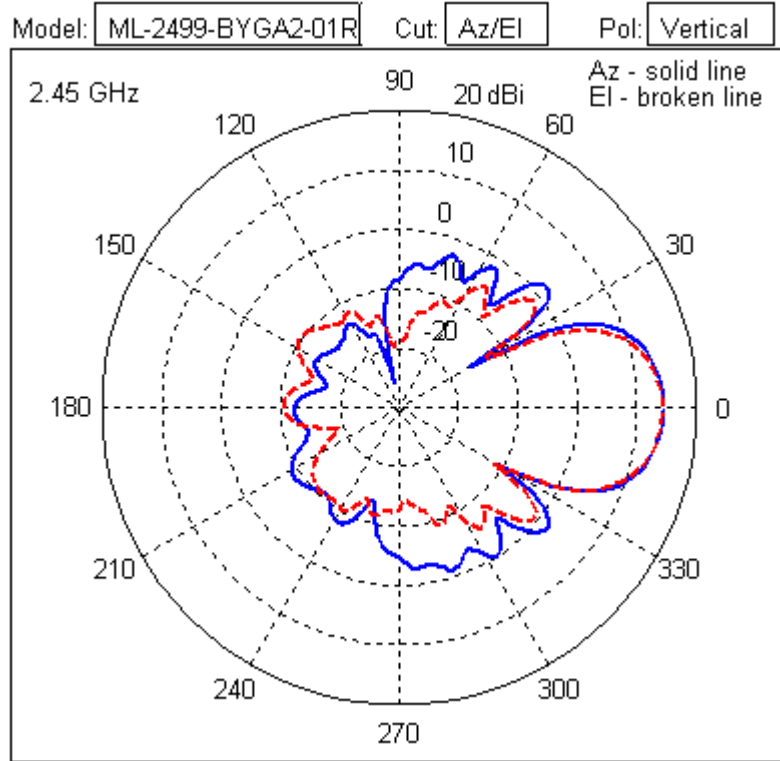

3.1.10 ML-2499-HPA3-01R High Performance Omni-Directional "Pipe" Antenna: RP-BNC Male

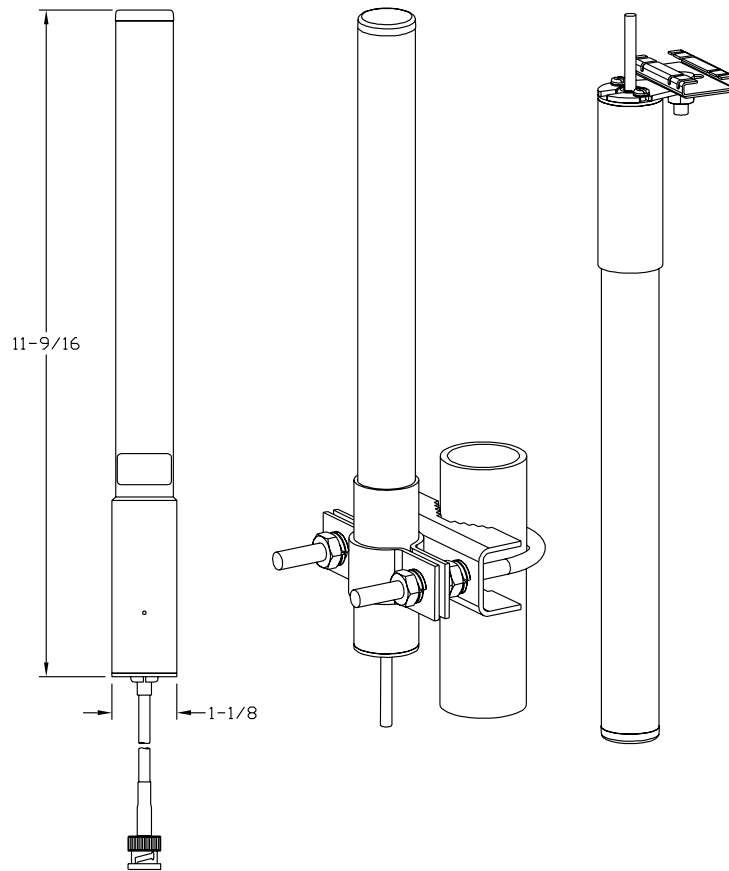

<i>Type</i>	Dipole Array
<i>Frequency</i>	2400-2500 MHz
<i>Max/Typ Gain (dBi)</i>	4.0/2.4
<i>Polarization</i>	Linear, Vertical
<i>Azimuth</i>	3dB Beamwidth: 360°
<i>Elevation</i>	3dB Beamwidth: 31°
<i>Cable Length (in.)</i>	48
<i>Cable Type</i>	RG-58 Ultralink
<i>Connector Type</i>	RP-BNC Male
<i>Weight</i>	0.3 lbs
<i>Plenum Antenna</i>	No
<i>Plenum Cable</i>	Yes
<i>Outdoor Rated</i>	Yes (in a cable down orientation)

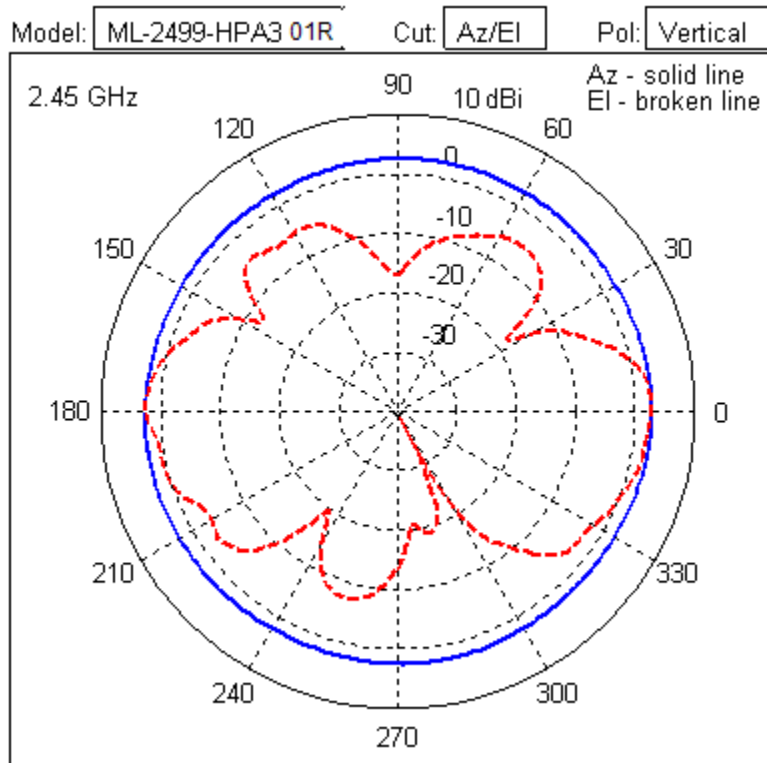

3.1.11 ML-2499-HPA3-02R Dipole Omni Antenna: RP-SMA Male

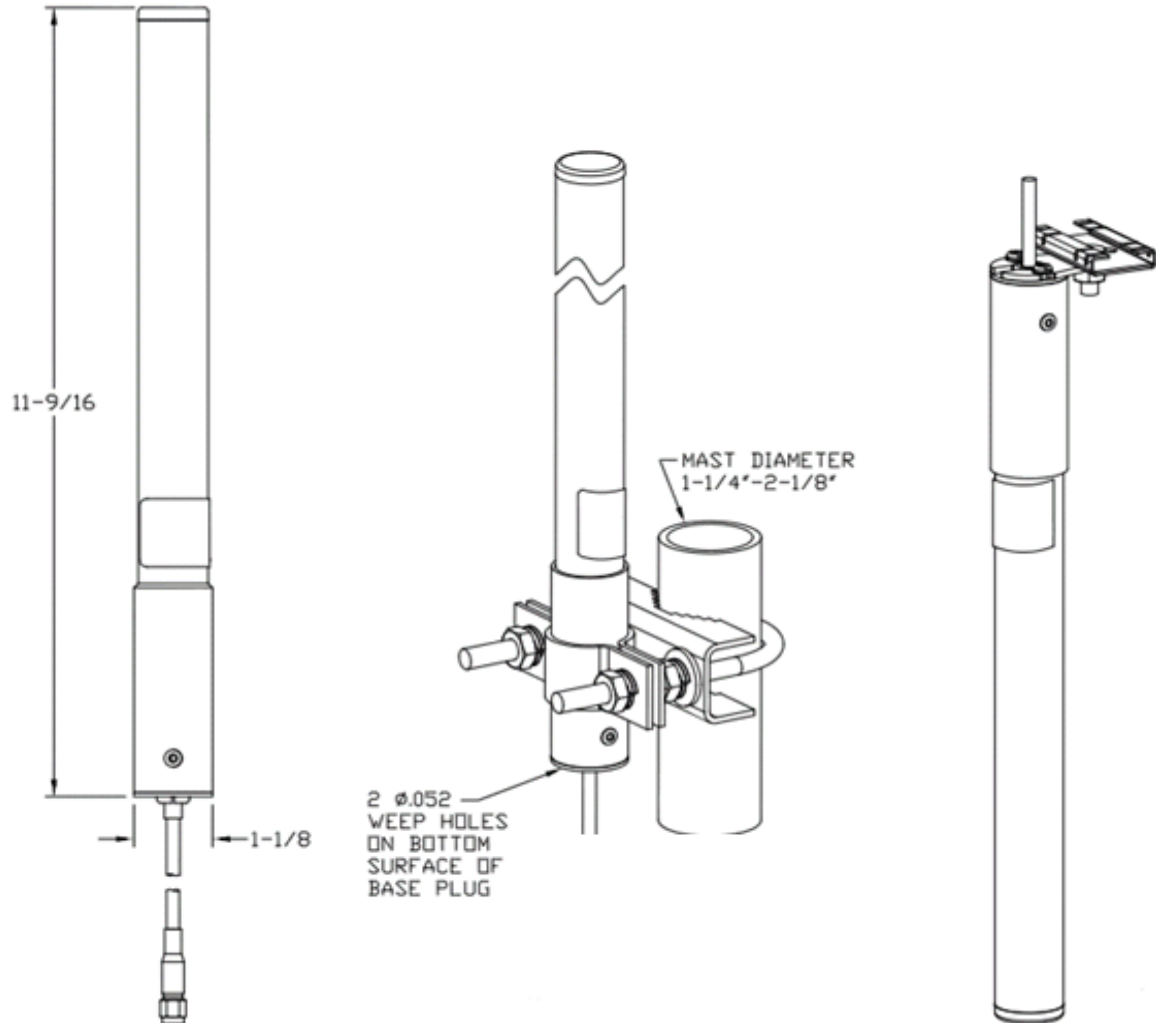

Type	Dipole Omni
Frequency	2400-2500 MHz
Gain (dBi)	5.0
Polarization	Linear, Vertical
Azimuth	3dB Beamwidth: 360°
Elevation	3dB Beamwidth: 32°
Cable Length (in.)	48
Cable Type	RG-58 Ultralink
Connector Type	RP-SMA Male
Weight	0.3 lbs
Plenum Antenna	No

<i>Plenum Cable</i>	Yes
<i>Outdoor Rated</i>	Yes (in a cable down orientation)

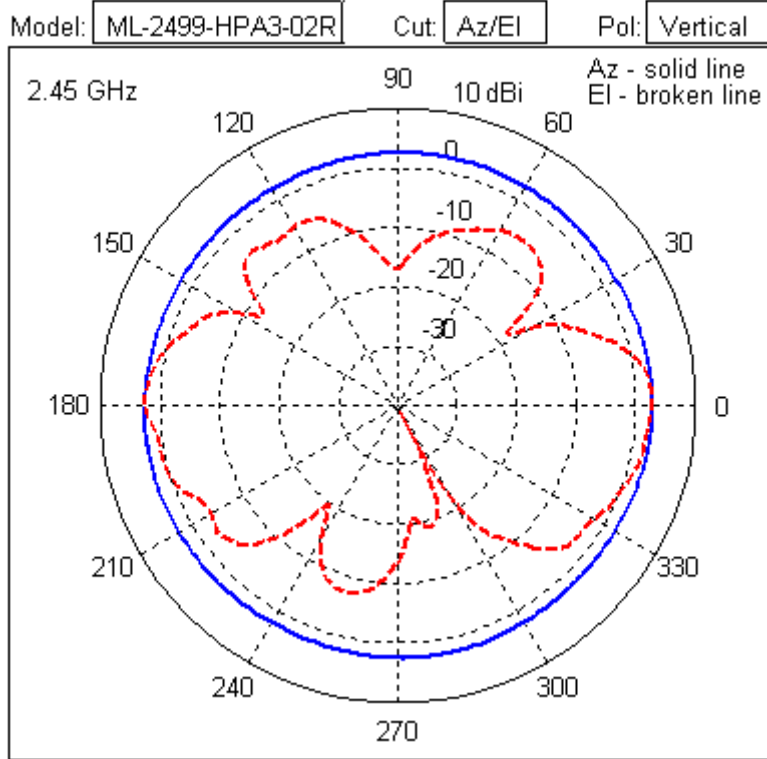

3.1.12 ML-2499-PNAHD-01R Indoor 55° Directional Panel: RP-BNC Male

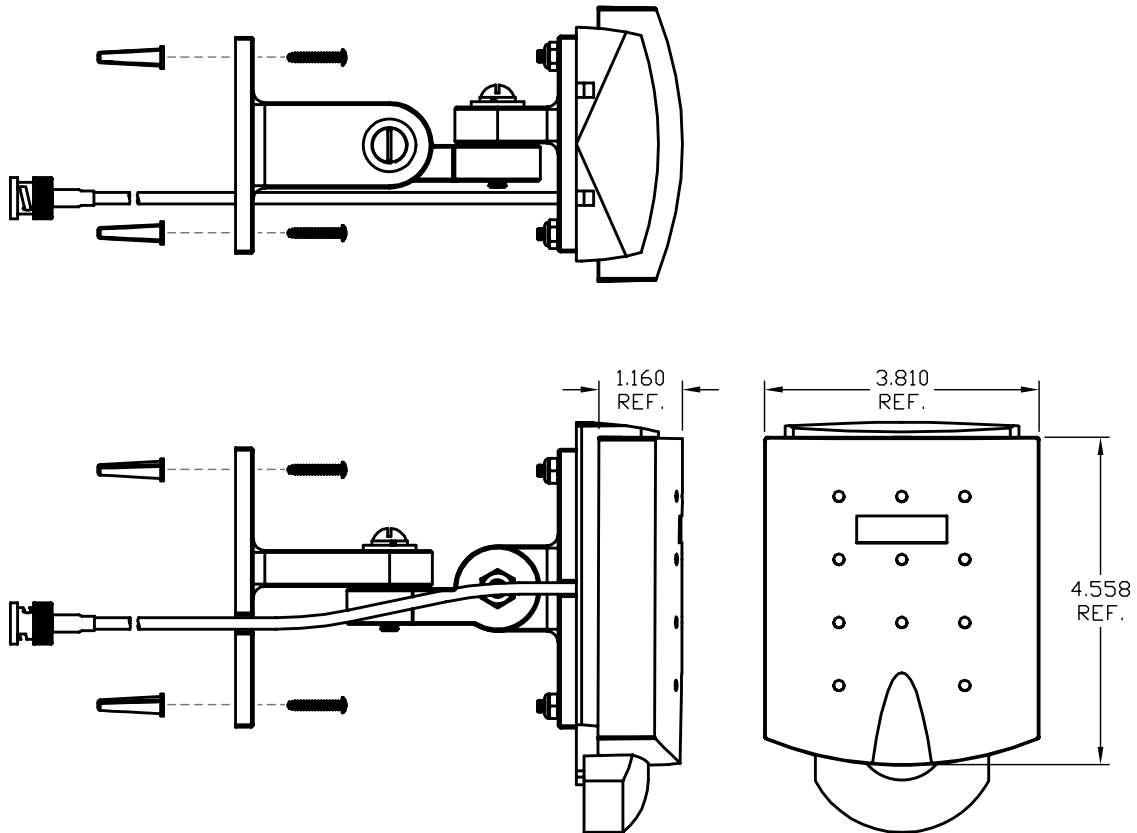

Type	Panel
Frequency	2400-2500 Mhz
Gain (dBi)	7.5
Polarization	Linear, Vertical
Azimuth	3dB Beamwidth: 65°
Elevation	3dB Beamwidth: 50 °
Cable Length (in.)	48
Cable Type	RG-58 Ultralink
Connector Type	RP-BNC Male
Weight	0.5 lbs
Plenum Antenna	No
Plenum Cable	Yes
Outdoor Rated	No

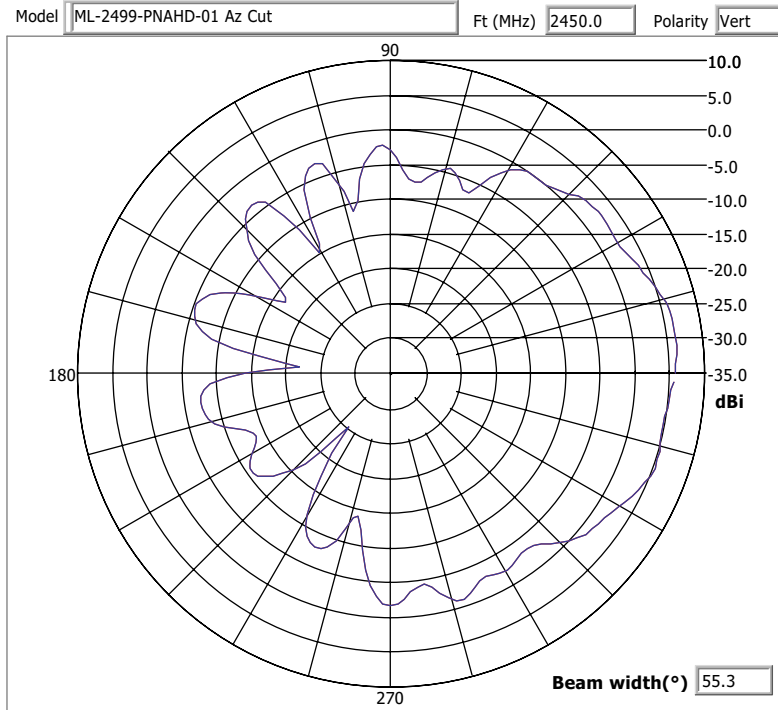

11/12/2003 6:41:17 PM

Azimuth Pattern

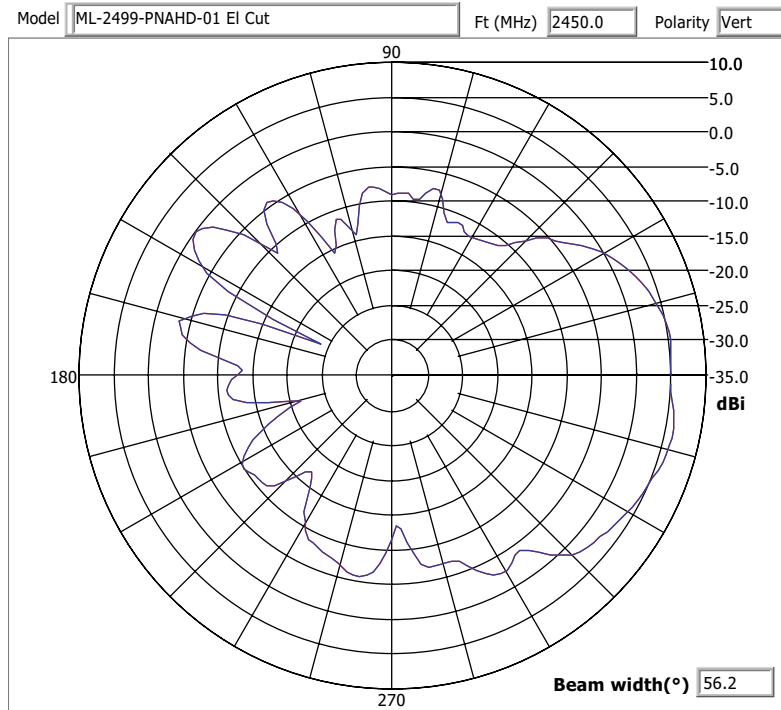

11/12/2003 6:44:37 PM

Elevation Pattern

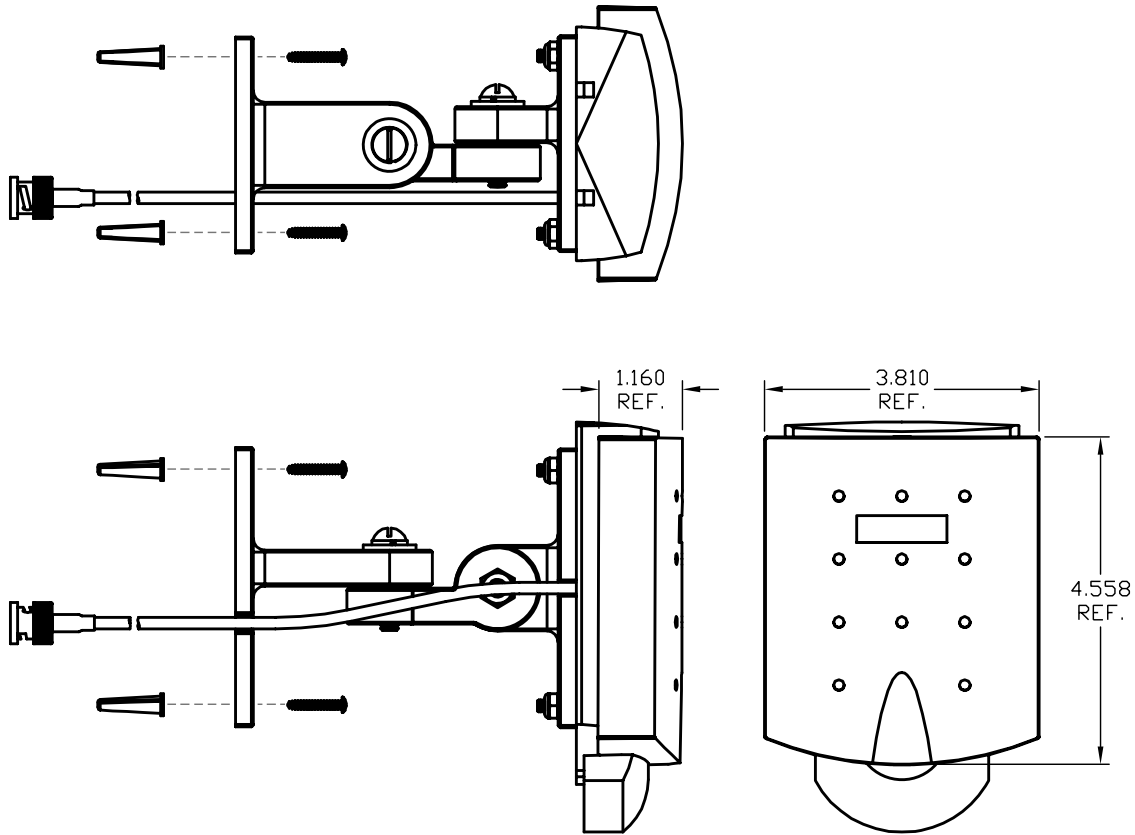
3.1.13 ML-2499-PNAHD-02R Outdoor Patch Antenna: RP-SMA Male

Type	Patch
Frequency	2400-2500 Mhz
Gain (dBi)	7.5
Polarization	Linear, Vertical
Azimuth	3dB Beamwidth: 65°
Elevation	3dB Beamwidth: 55 °
Cable Length (in.)	48
Cable Type	RG-58
Connector Type	RP-SMA Male
Weight	0.5 lbs
Plenum Antenna	No
Plenum Cable	Yes
Outdoor Rated	No
Storage Temperature Range (C)	-30 / +70
Operation Temperature Range (C)	-30 / +70

Model: Cut: Pol:

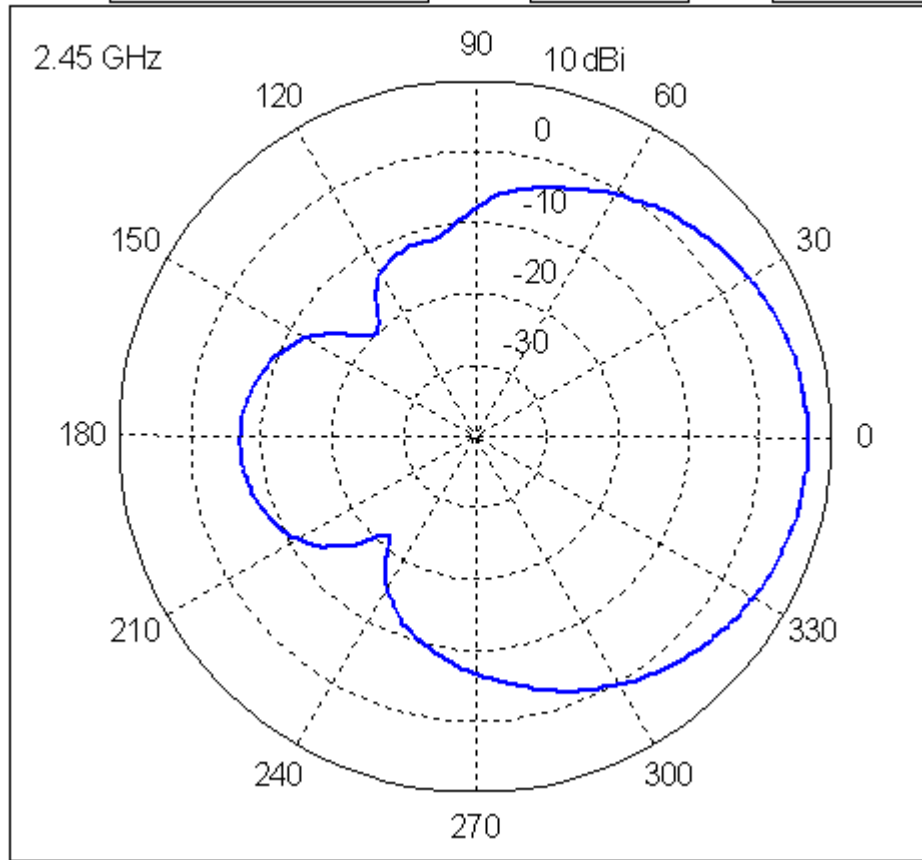

Model: Cut: Pol:

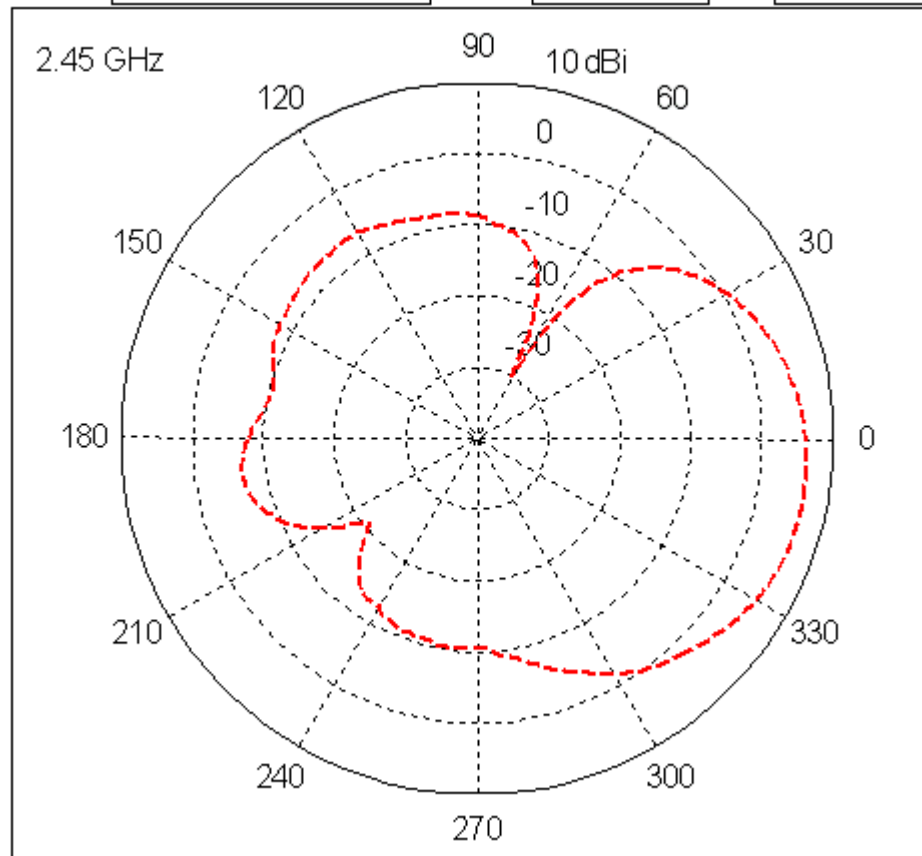

3.1.14 ML-2499-SD3-01R Low Profile Ceiling/Surface Mount Omni-Directional Patch: RP-BNC Male

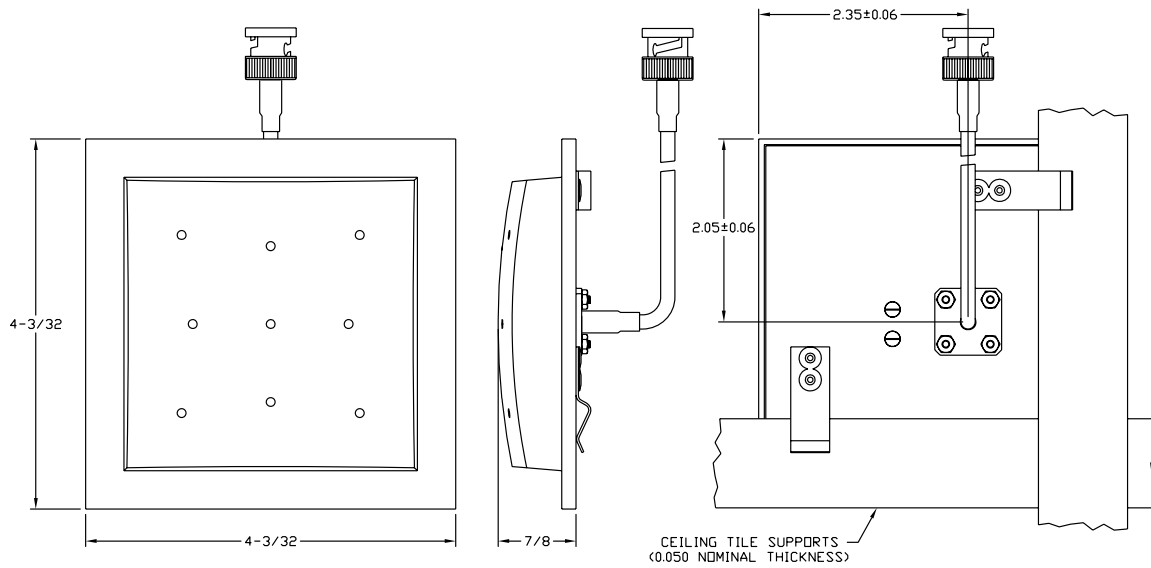

Type	Patch (ceiling mount)
Frequency	2400-2500 MHz
Max/Typ Gain (dBi)	4.0/3.5
Polarization	Linear, Vertical
Azimuth	3dB Beamwidth: 360°
Elevation	3dB Beamwidth: 45°
Cable Length (in.)	48
Cable Type	RG-58 Ultralink
Connector Type	RP-BNC Male
Weight	0.21 lbs
Plenum Antenna	No
Plenum Cable	Yes
Outdoor Rated	No

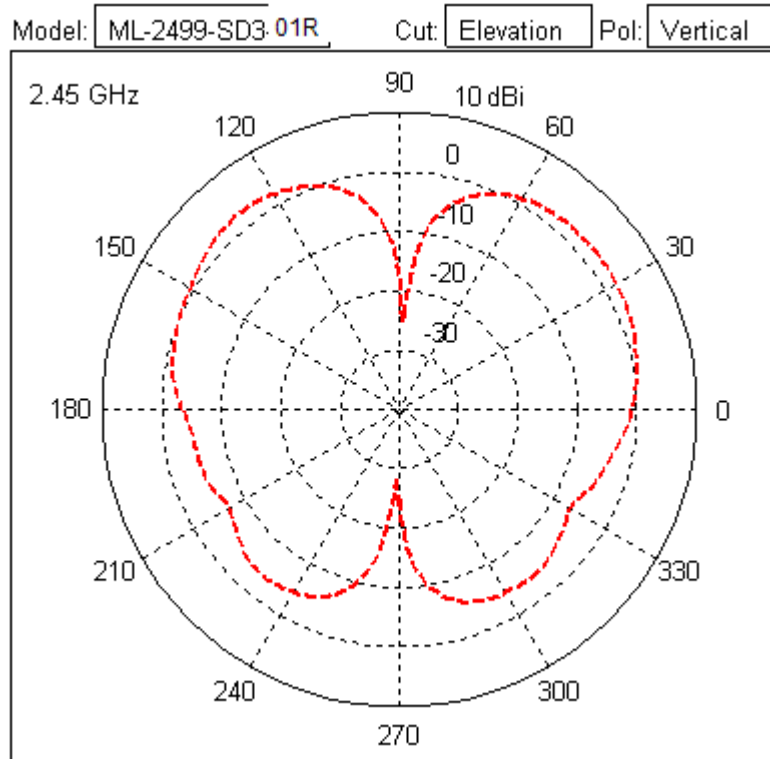
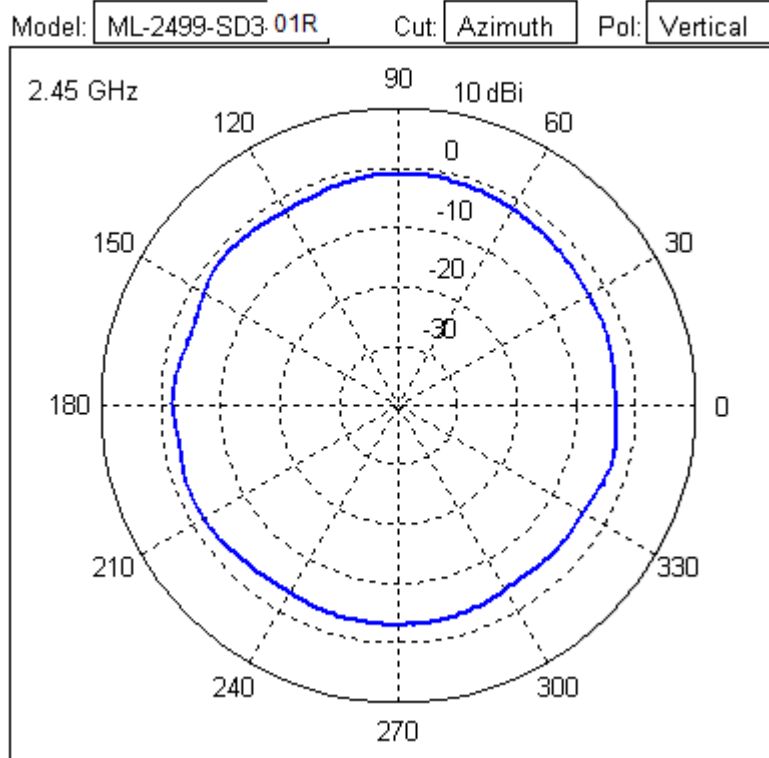

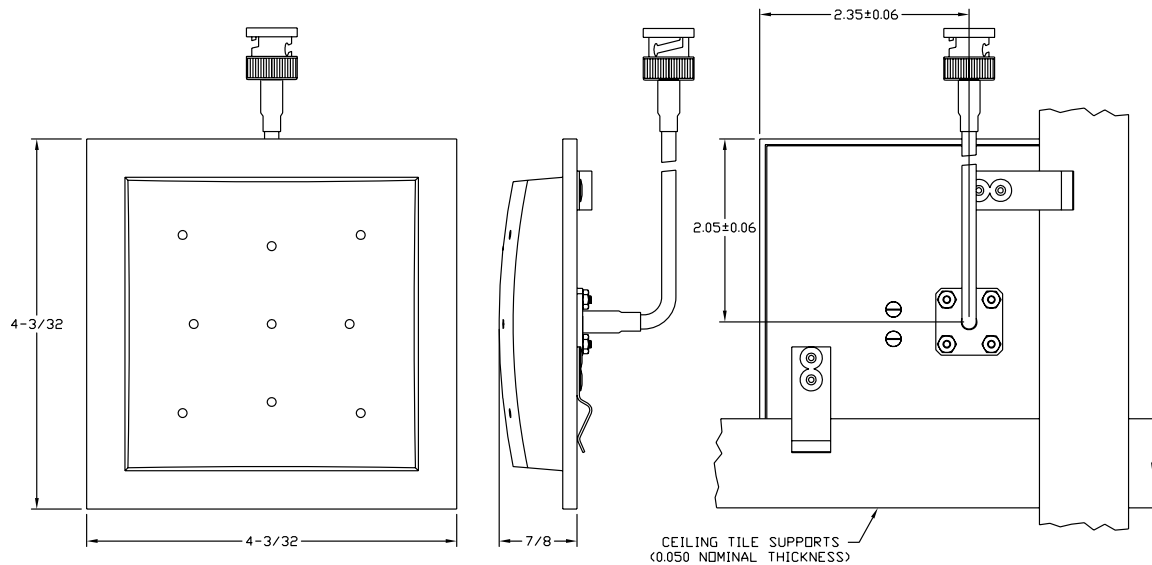
3.1.15 ML-2499-SD3-02R Patch Omni Antenna: RP-SMA Male

<i>Type</i>	Patch Omni
<i>Frequency</i>	2400-2500 MHz
<i>Gain (dBi)</i>	4.0
<i>Polarization</i>	Linear, Vertical
<i>Azimuth</i>	3dB Beamwidth: 360°
<i>Elevation</i>	3dB Beamwidth: 50°
<i>Cable Length (in.)</i>	48
<i>Cable Type</i>	RG-58 Ultralink
<i>Connector Type</i>	RP-SMA Male
<i>Weight</i>	0.52 lbs
<i>Plenum Antenna</i>	No
<i>Plenum Cable</i>	Yes
<i>Outdoor Rated</i>	No
<i>Storage Temperature Range (C)</i>	-30 / +70
<i>Operation Temperature Range (C)</i>	-30 / +70

Model: Cut: Pol:

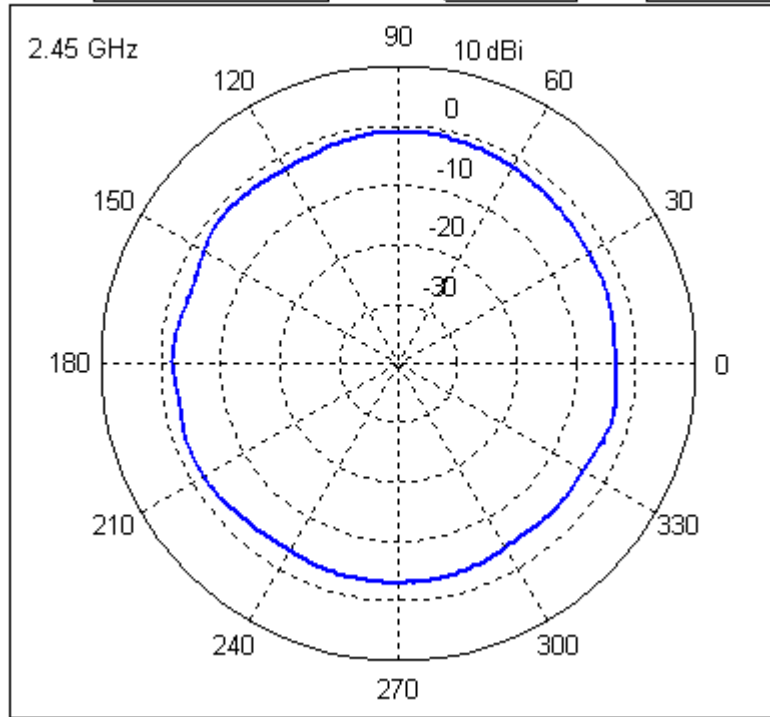

Model: Cut: Pol:

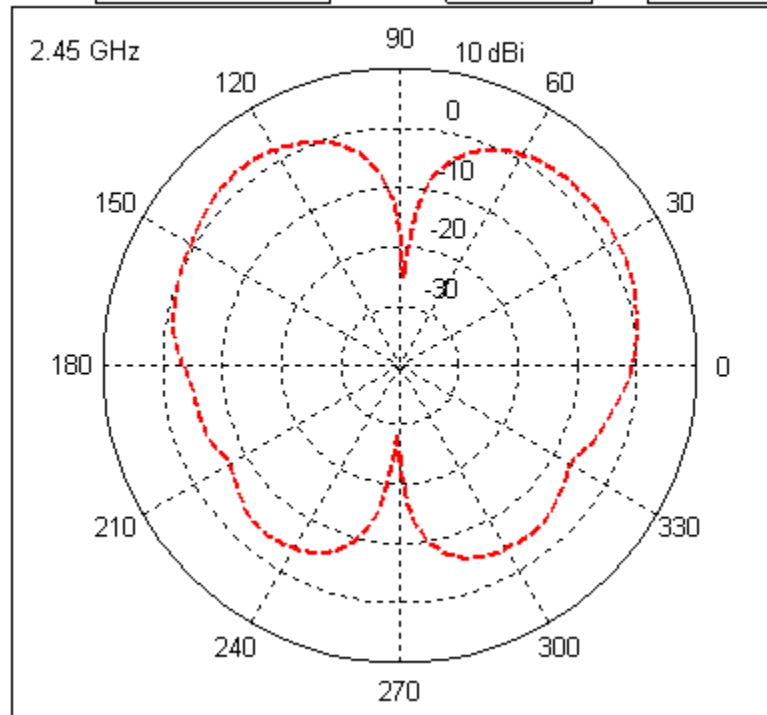

3.1.16 ML-2499-FHPA5-01R Omni-Directional "Pipe" Antenna: N Male Connector



ML-2499-FHPA5-01R

<i>Type</i>	Dipole Array
<i>Frequency</i>	2400-2500 MHz
<i>Gain (dBi)</i>	5
<i>Polarization</i>	Linear, Vertical
<i>Azimuth</i>	3dB Beamwidth: 360°
<i>Elevation</i>	3dB Beamwidth: 25°
<i>Cable Length (in.)</i>	N/A
<i>Cable Type</i>	N/A
<i>Connector Type</i>	Type N Male
<i>Weight</i>	0.7 lbs
<i>Plenum Antenna</i>	No
<i>Plenum Cable</i>	N/A
<i>Outdoor Rated</i>	Yes

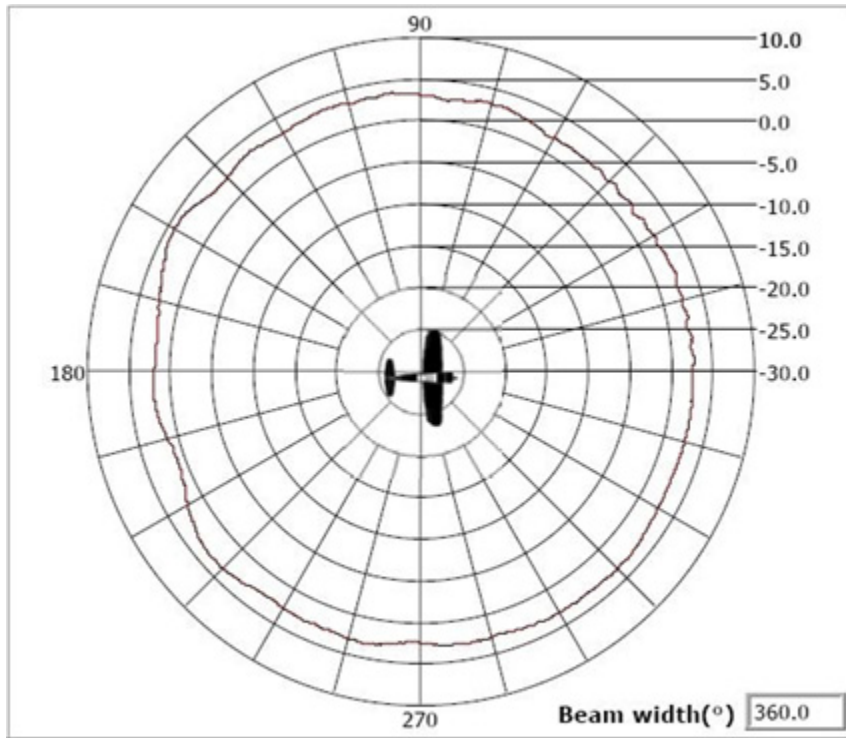

Azimuth Pattern 2450 MHz

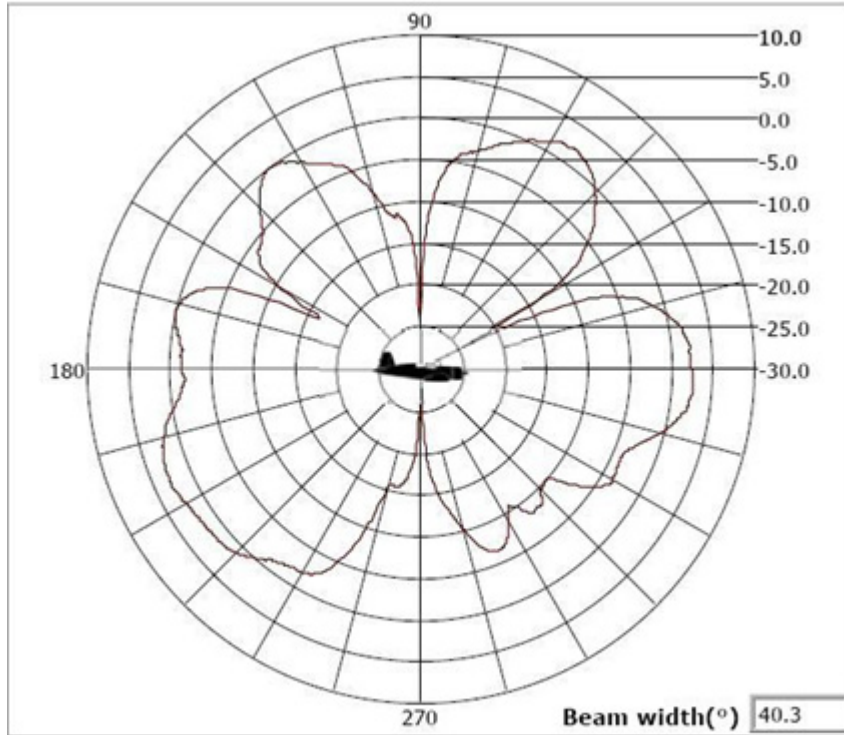

Elevation Pattern 2450 MHz

3.1.17 ML-2499-FHPA9-01R High Performance Fixed Point Dipole: Male Connector

ML-2499-FHPA9-01R

<i>Type</i>	Dipole Array
<i>Frequency</i>	2400-2500 MHz
<i>Max/Typ Gain (dBi)</i>	10.5/9.3
<i>Polarization</i>	Linear, Vertical
<i>Azimuth</i>	3dB Beamwidth: 360°
<i>Elevation</i>	3dB Beamwidth: 14°
<i>Cable Length (in.)</i>	N/A
<i>Cable Type</i>	N/A
<i>Connector Type</i>	Type N Male
<i>Weight</i>	1.1 lbs
<i>Plenum Antenna</i>	No
<i>Plenum Cable</i>	N/A
<i>Outdoor Rated</i>	Yes

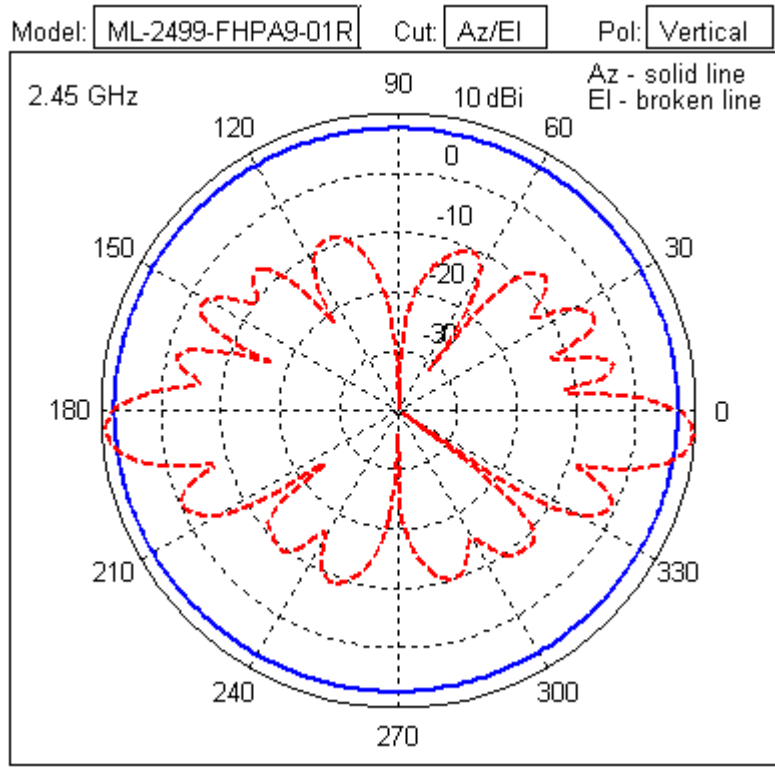

3.1.18 ML-2499-HPA4-01 Outdoor Dipole Omni Antenna: N Male Connector

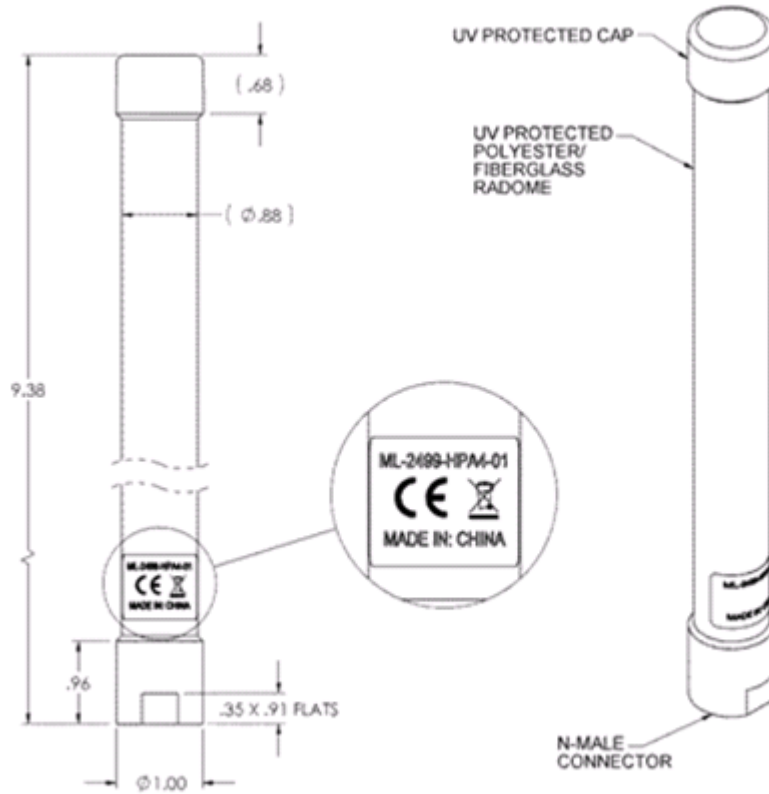

Type	Dipole
Frequency	2400-2500 MHz
Gain (dBi)	4.5
Polarization	Linear, Vertical
Azimuth	3dB Beamwidth: 360°
Elevation	3dB Beamwidth: 42°
Cable Length (in.)	n/a
Cable Type	n/a
Connector Type	N-Type Male
Weight	118 grams
Plenum Antenna	No
Plenum Cable	n/a
Outdoor Rated	Yes

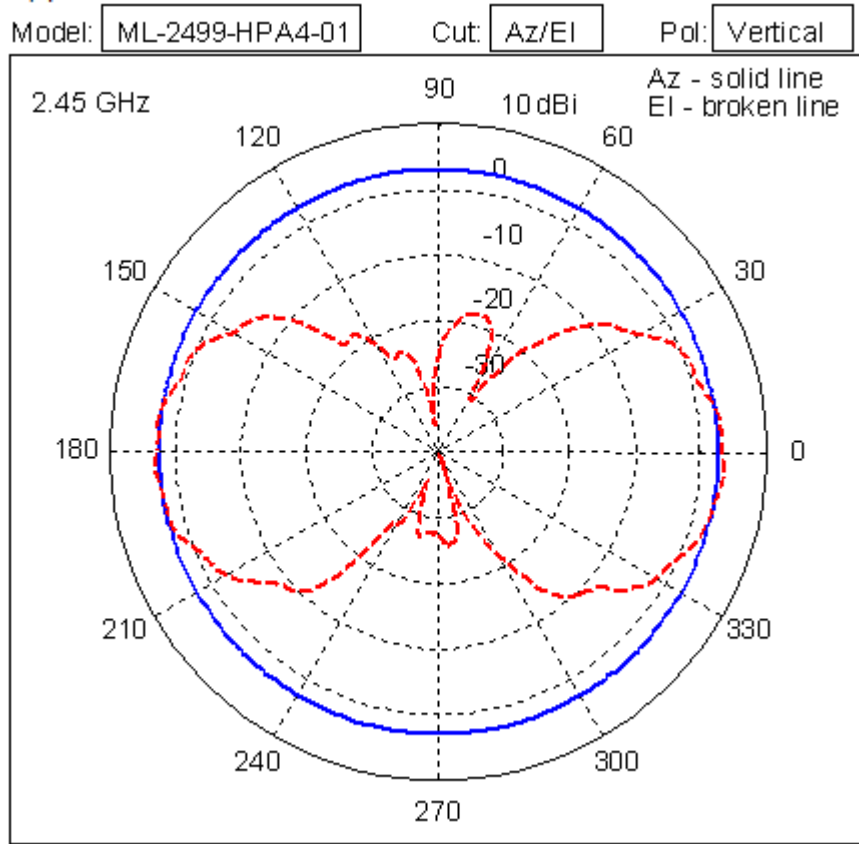

3.1.19 ML-2499-HPA8-01 Outdoor Dipole Omni Antenna: N Male Connector

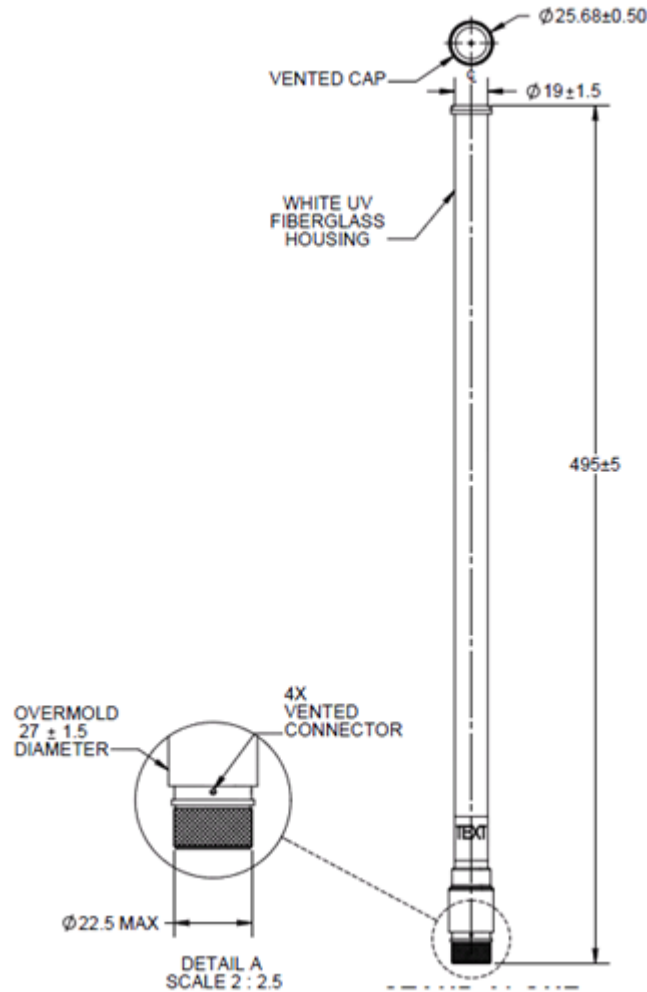

Type	Dipole, Omni
Frequency	2400-2500 MHz
Gain (dBi)	8
Polarization	Linear, Vertical
Azimuth	3dB Beamwidth: 360°
Elevation	3dB Beamwidth: 14°
Cable Length (in.)	n/a
Cable Type	n/a
Connector Type	N-Type Male
Weight	0.45 lbs
Plenum Antenna	No

Plenum Cable	n/a
Outdoor Rated	Yes

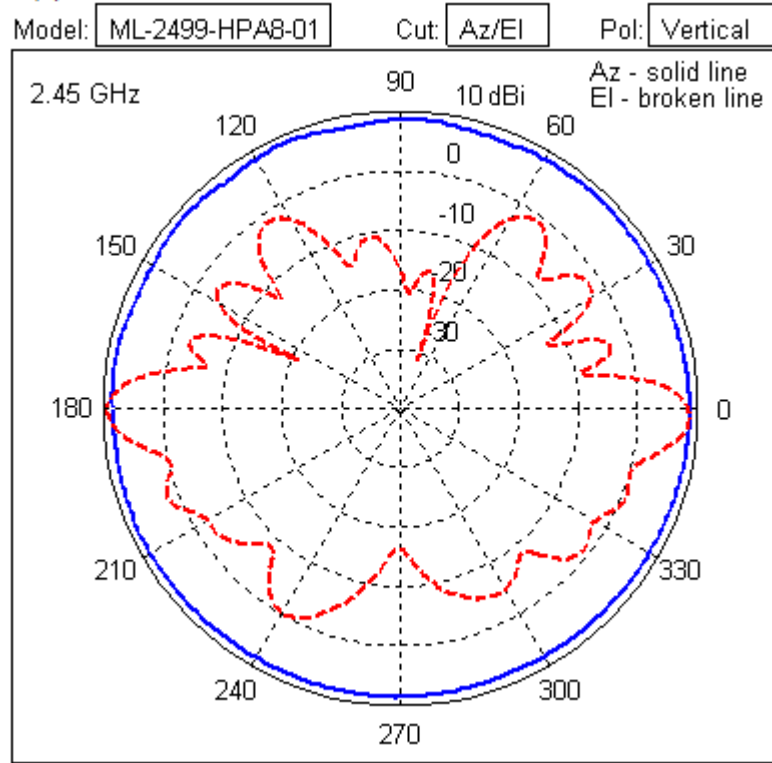

5.2 Ghz Single Band Antenna Suite

4.1 Supported 802.11a/n Antenna Suite

Motorola Solutions supports numerous 802.11a/n antennas to suit the requirements of your unique access point or access port deployment. Check the Motorola Solutions Web site periodically, as newly supported 802.11a/n antennas will be added to this document as they are released. For more information, go to <http://supportcentral.motorola.com/support/product/manuals.do>.

For detailed information on supported 802.11a/n antenna models, refer to:

- *ML-5299-APA1-01R Indoor Rubber Flex Jointed Dipole: RP-SMA Male Connector*
- *ML-5299-HPA1-01R High Performance Omni-Directional Dipole Antenna: RP-SMA Male Connector*
- *ML-5299-PTA1-01R Low Profile Ceiling-Tile Mount Patch: RP-SMA Male Connector*
- *ML-5299-WPNA1-01R Wall Mount Panel Antenna w/Articulating Mount: RP-SMA Male*
- *ML-5299-FHPA10-01R Omni-Directional "Pipe" Antenna: N-Male Connector*
- *ML-5299-FHPA6-01R Omni-Directional "Pipe" Antenna: N-Male Connector*
- *ML-5299-BYGA15-012 Yagi Antenna: N-Female*
- *ML-5299-HPA5-01 Outdoor Dipole Omni N-Male*
- *ML-5299-HPA10-01 Outdoor Dipole Omni N-Male*



NOTE: For examples on how various antenna and connectors are deployed in a 5 GHz AP-5131 installation, see [5 GHz AP-5131 Antenna Connections](#).

4.1.1 ML-5299-APA1-01R Indoor Rubber Flex Jointed Dipole: RP-SMA Male Connector

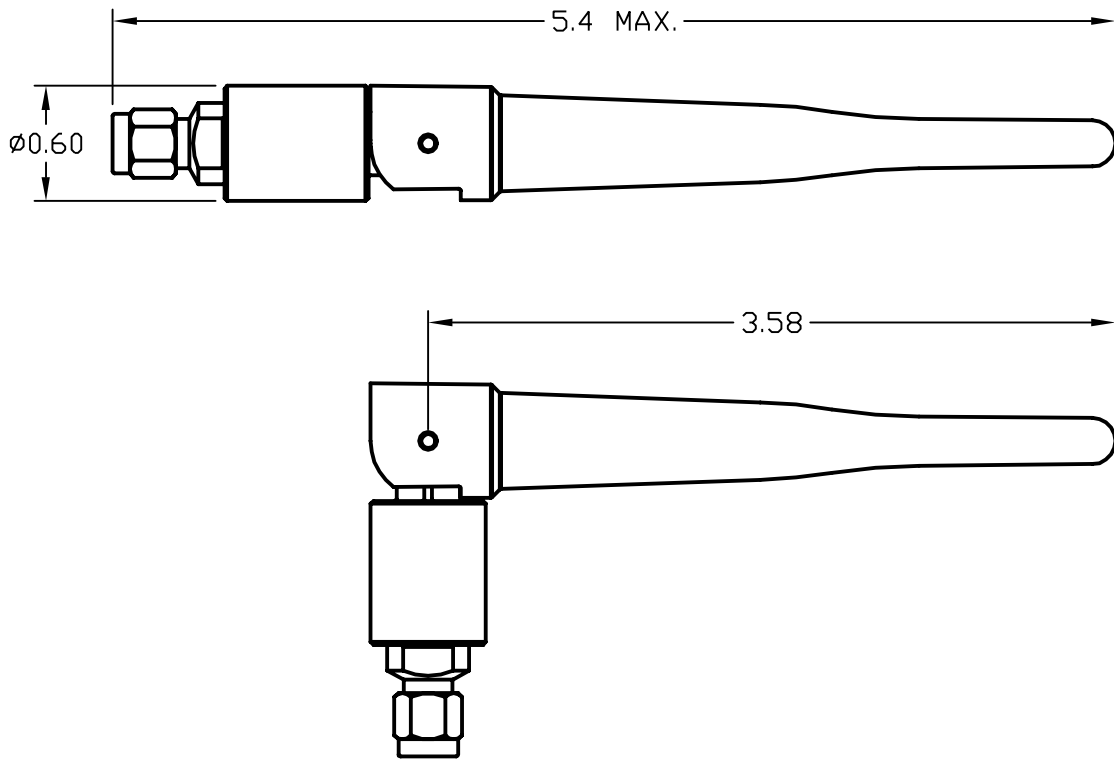

Type	Dipole
Frequency	5150-5350, 5725-5875
Gain (dBi)	4.0
Polarization	Linear, Vertical
Azimuth	3dB Beamwidth: 360°
Elevation	3dB Beamwidth: 60°
Cable Length (in.)	N/A
Cable Type	N/A
Connector Type	RP-SMA Male
Weight	0.3 lb
Plenum Antenna	No
Plenum Cable	N/A
Outdoor Rated	No
Storage Temp Range (C)	-30 / +85
Operation Temp Range (C)	-20 / +75

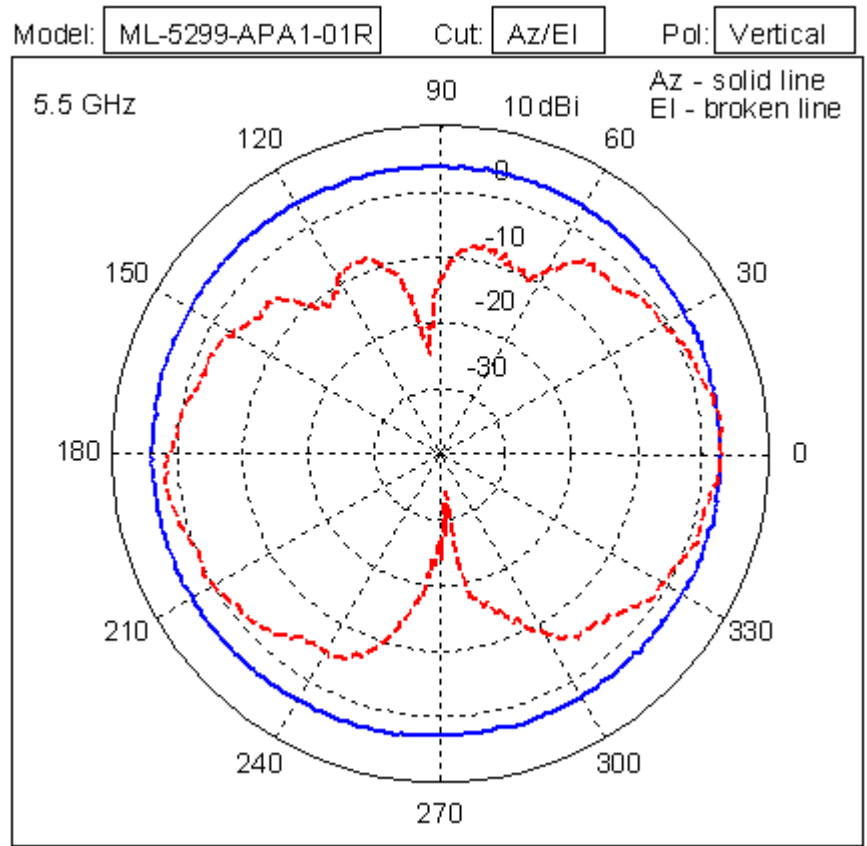

4.1.2 ML-5299-HPA1-01R High Performance Omni-Directional Dipole Antenna: RP-SMA Male Connector

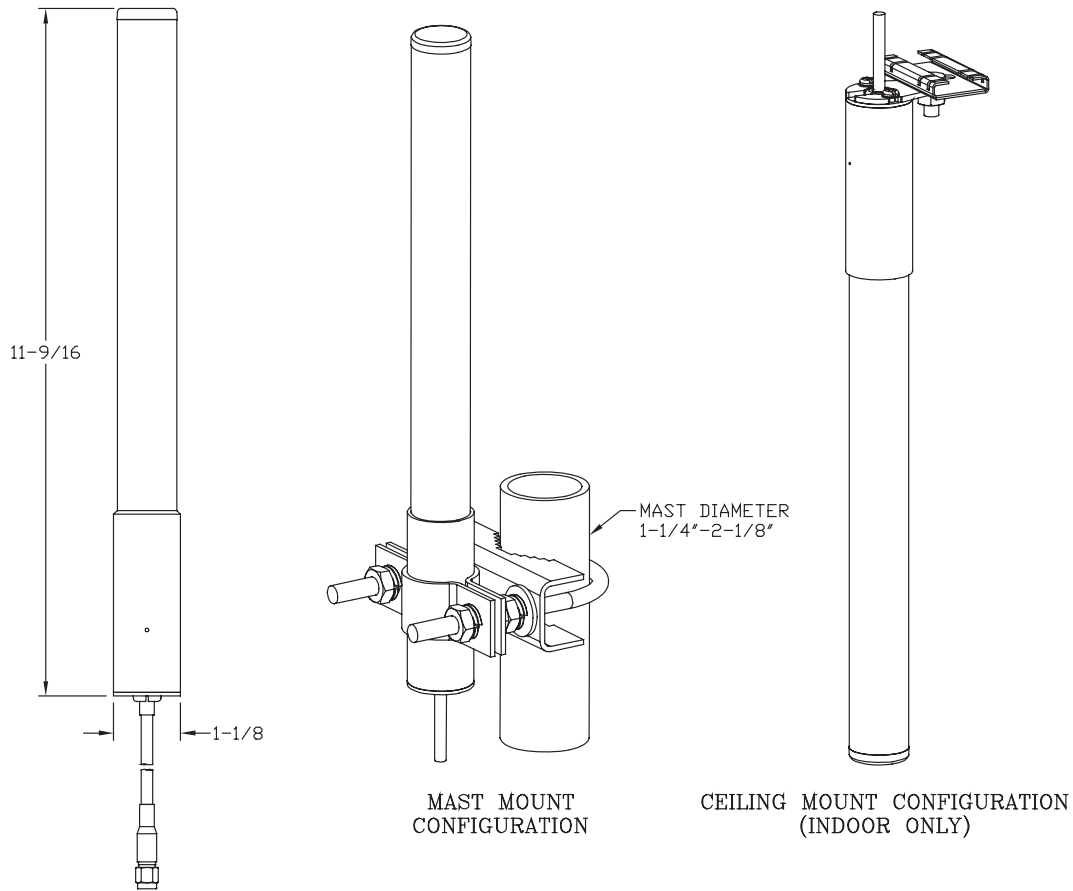

Type	Dipole Array
Frequency	4900-5875 MHz
Gain (dBi)	6.0
Polarization	Linear, Vertical
Azimuth	3dB Beamwidth: 360°
Elevation	3dB Beamwidth: 17°
Cable Length (in.)	36
Cable Type	RG-58
Connector Type	RP-SMA Male
Weight	0.3 lb.
Plenum Antenna	No
Plenum Cable	Yes
Outdoor Rated	Yes (cable down orientation only)
Storage Temp Range (C)	-40 / +80
Operation Temp Range (C)	-30 / +70

Model: Cut: Pol:

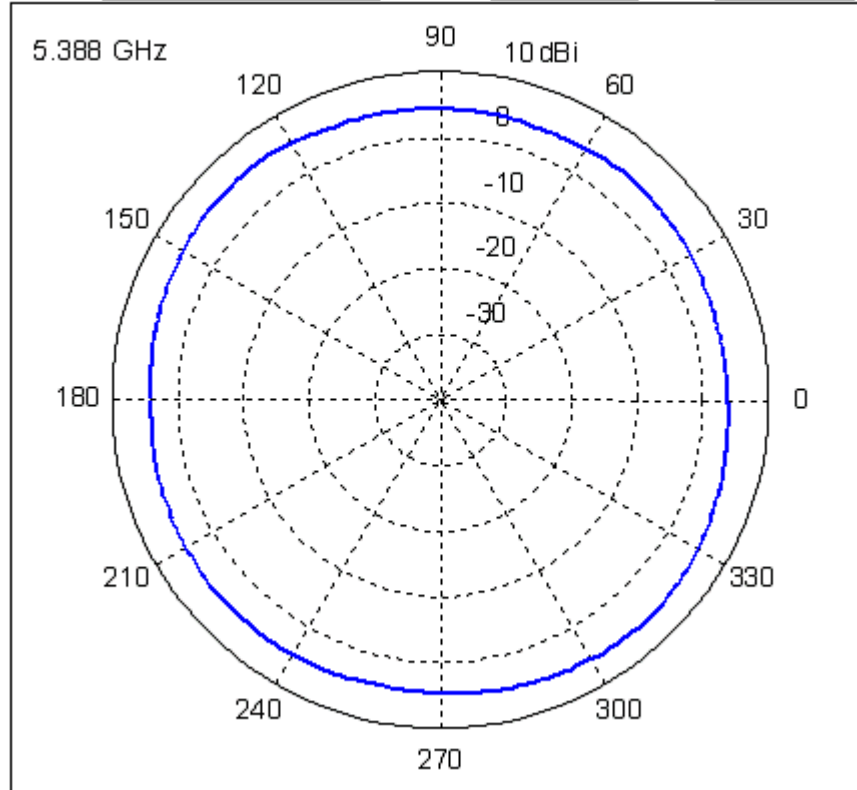

Model: Cut: Pol:

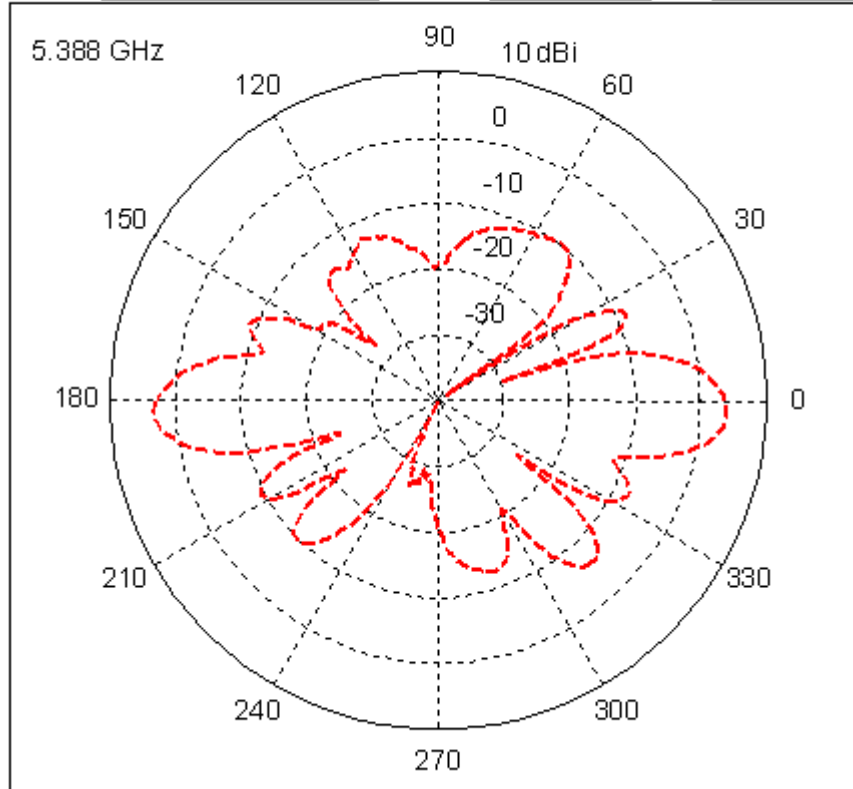

4.1.3 ML-5299-PTA1-01R Low Profile Ceiling-Tile Mount Patch: RP-SMA Male Connector

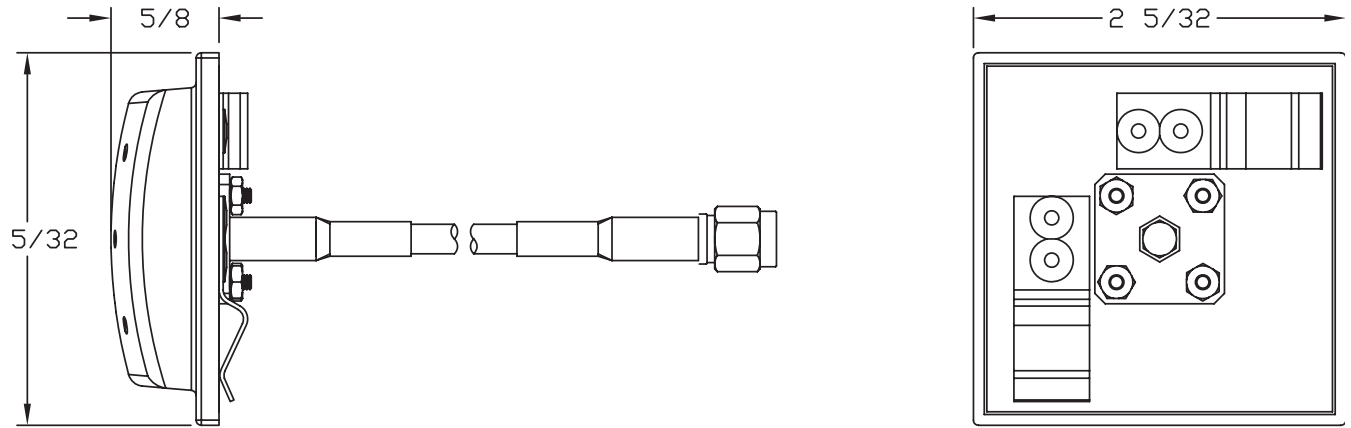

<i>Type</i>	Patch
<i>Frequency</i>	5150-5875 MHz
<i>Max/Typ Gain (dBi)</i>	3.8/3.0
<i>Polarization</i>	Linear, Vertical
<i>Azimuth</i>	3dB Beamwidth: 360°
<i>Elevation</i>	3dB Beamwidth: 45°
<i>Cable Length (in.)</i>	36
<i>Cable Type</i>	RG-58
<i>Connector Type</i>	RP-SMA Male
<i>Weight</i>	0.15 lb.
<i>Plenum Antenna</i>	No
<i>Plenum Cable</i>	Yes
<i>Outdoor Rated</i>	No

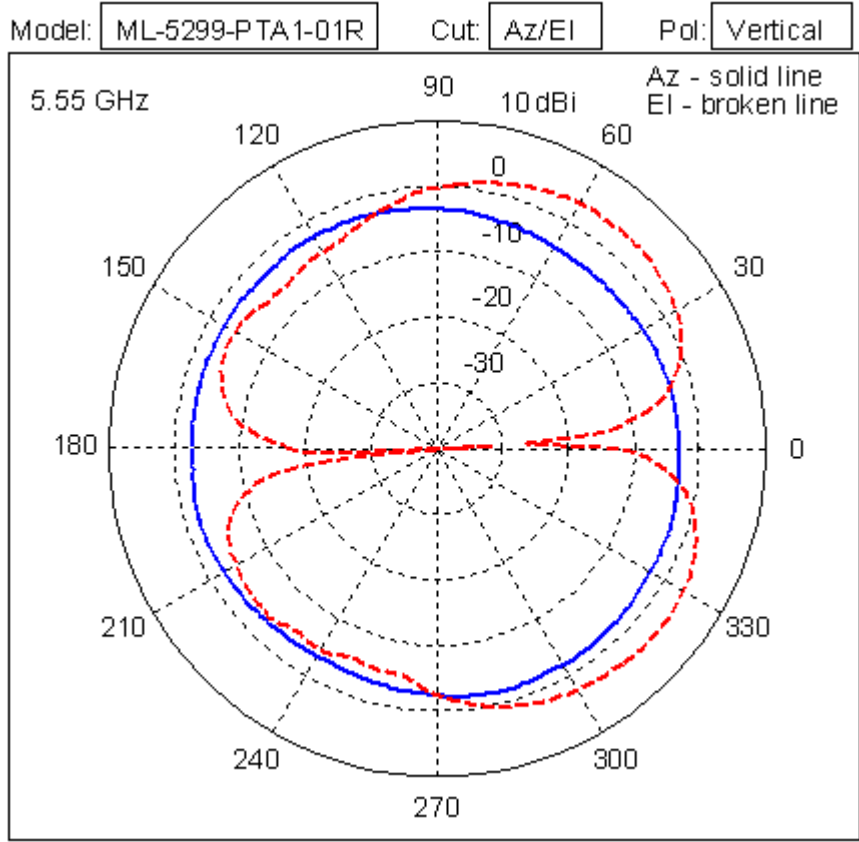

4.1.4 ML-5299-WPNA1-01R Wall Mount Panel Antenna w/Articulating Mount: RP-SMA Male

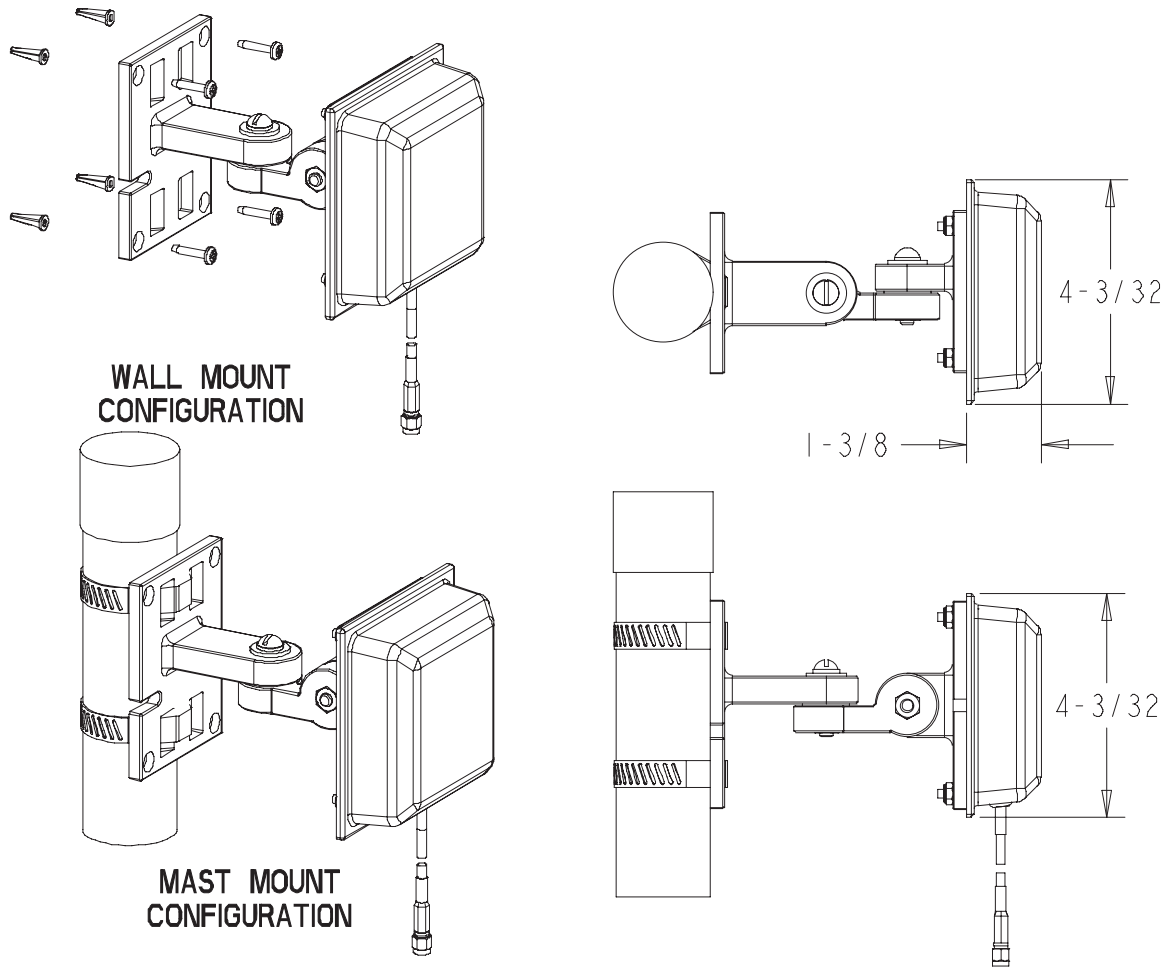

Type	Panel
Frequency	5150-5850 MHz
Gain (dBi)	14.0
Polarization	Linear, Vertical
Azimuth	3dB Beamwidth: 31°
Elevation	3dB Beamwidth: 27°
Cable Length (in.)	36
Cable Type	RG-58
Connector Type	RP-SMA Male
Weight	0.7 lb.
Plenum Antenna	No
Plenum Cable	Yes
Outdoor Rated	Yes

Storage Temp Range (C)	-30 / +70
Operation Temp Range (C)	-30 / +70

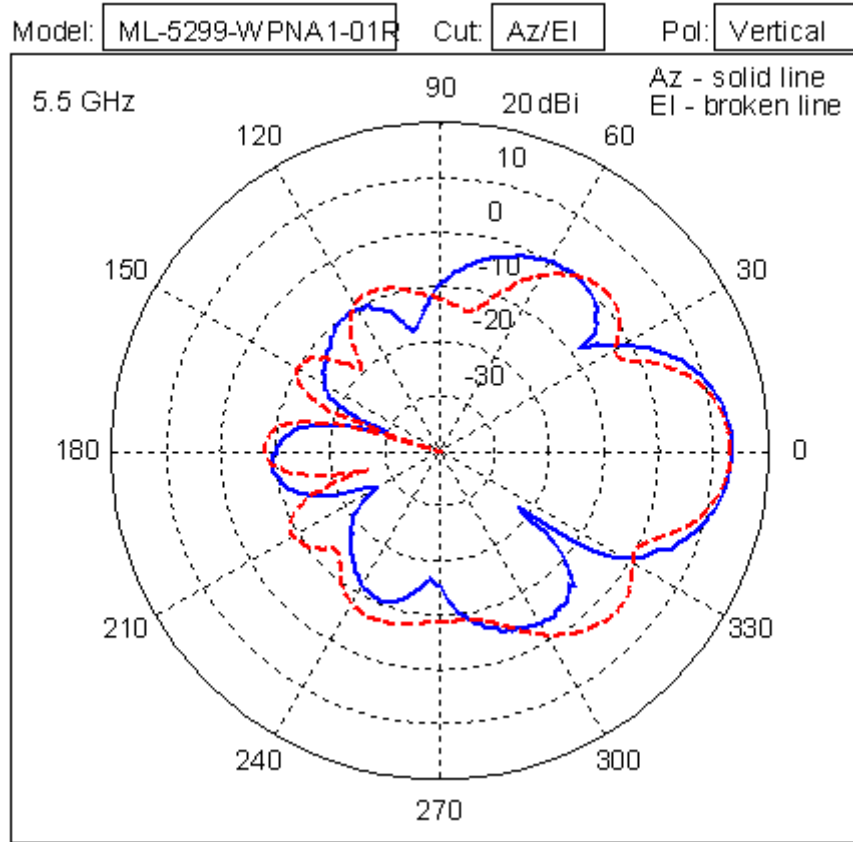

4.1.5 ML-5299-FHPA10-01R Omni-Directional "Pipe" Antenna: N-Male Connector



ML-5299-FHPA10-01R

<i>Type</i>	Dipole Array
<i>Frequency</i>	4900-5850 MHz
<i>Max/Typ Gain (dBi)</i>	10.8/10.0
<i>Polarization</i>	Linear, Vertical
<i>Azimuth</i>	3dB Beamwidth: 360°
<i>Elevation</i>	3dB Beamwidth: 13
<i>Cable Length (in.)</i>	N/A
<i>Cable Type</i>	N/A
<i>Connector Type</i>	Type N Male
<i>Weight</i>	0.37 lb
<i>Plenum Antenna</i>	No
<i>Plenum Cable</i>	N/A
<i>Outdoor Rated</i>	Yes

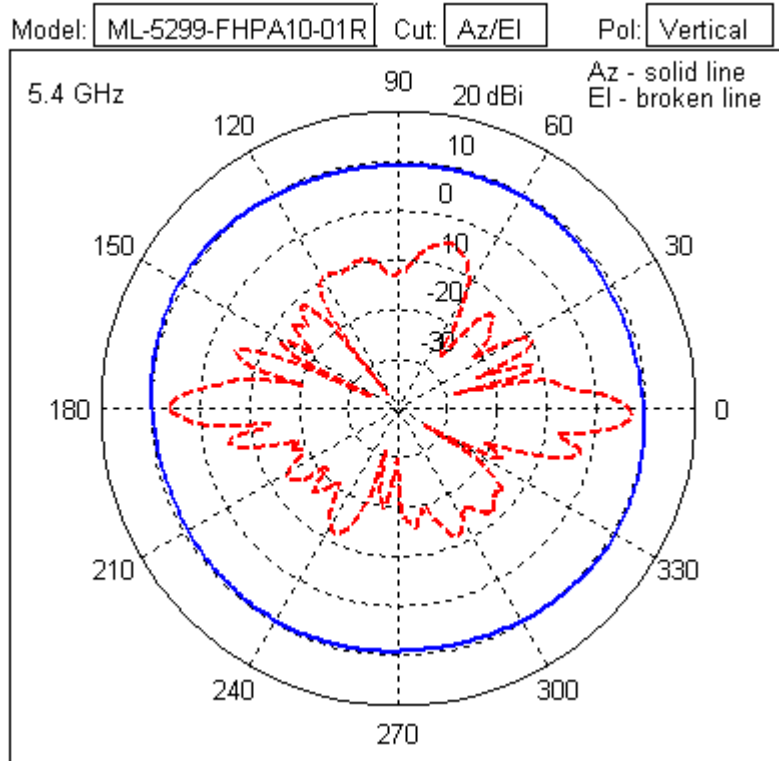

4.1.6 ML-5299-FHPA6-01R Omni-Directional "Pipe" Antenna: N-Male Connector

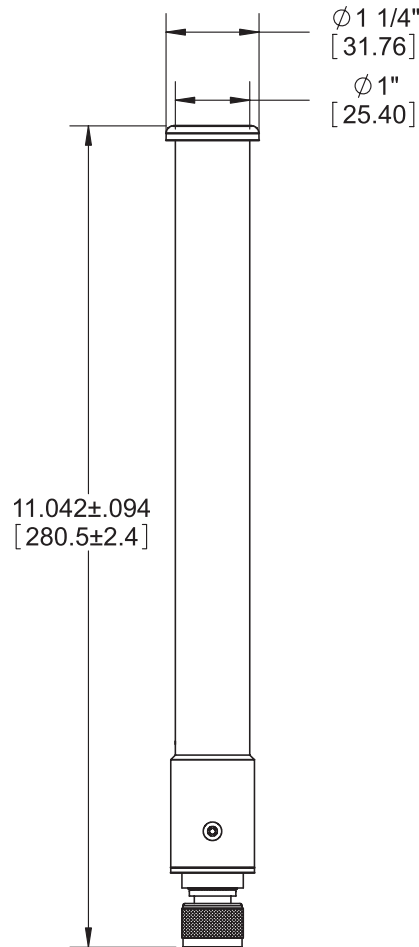

Type	Dipole Array
Frequency	4900-5875
Gain (dBi)	7.5
Polarization	Linear, Vertical
Azimuth	3dB Beamwidth: 360°
Elevation	3dB Beamwidth: 16°
Cable Length (in.)	N/A
Cable Type	N/A
Connector Type	Type N Male
Weight	0.37 lb
Plenum Antenna	No
Plenum Cable	N/A
Outdoor Rated	Yes

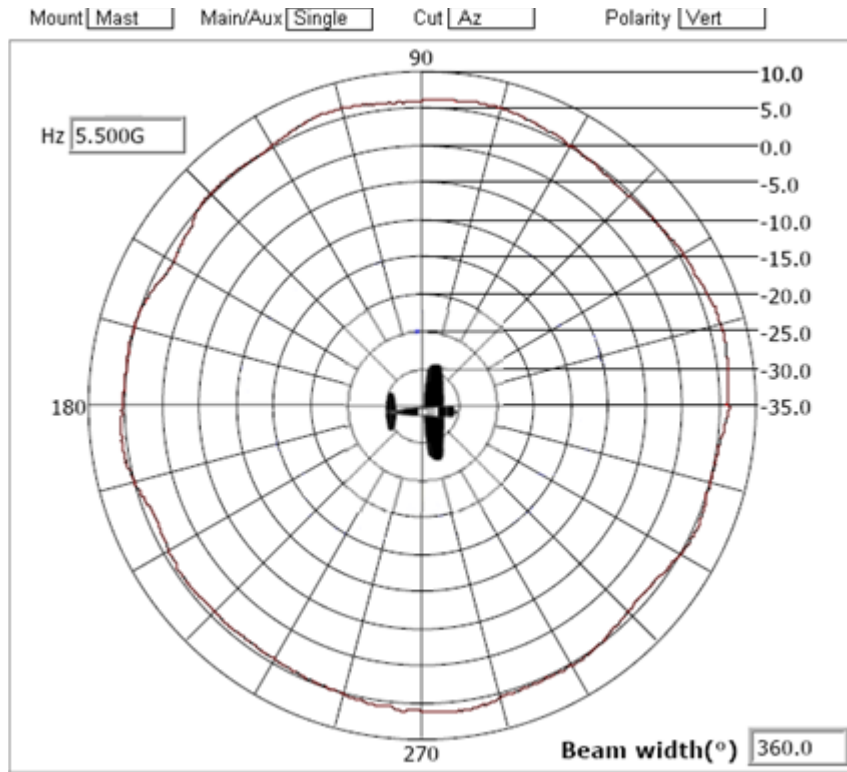

Azimuth Pattern

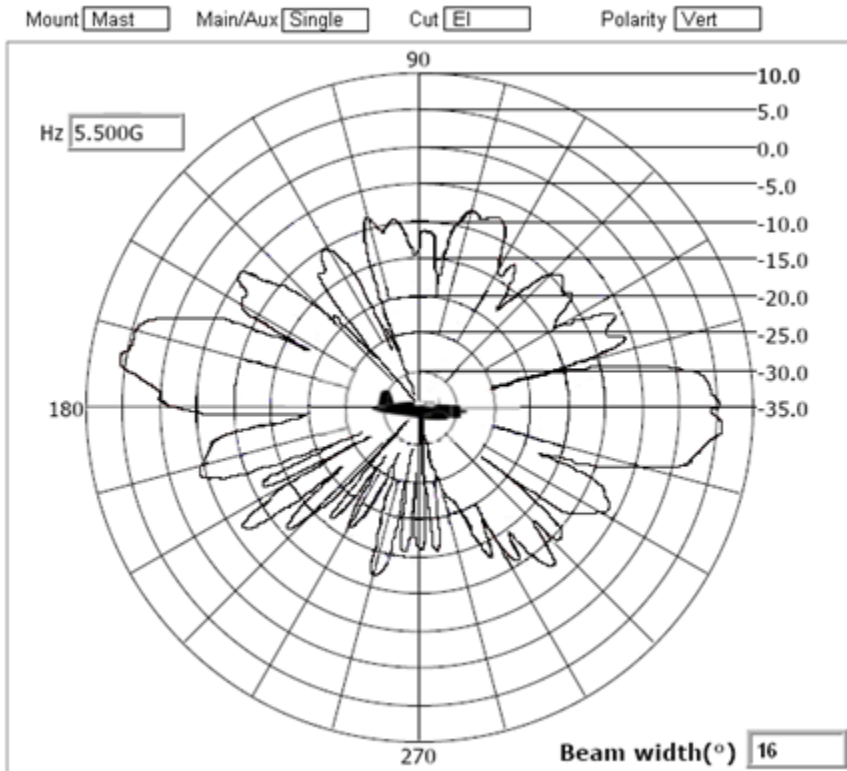

Elevation Pattern

4.1.7 ML-5299-BYGA15-012 Yagi Antenna: N-Female

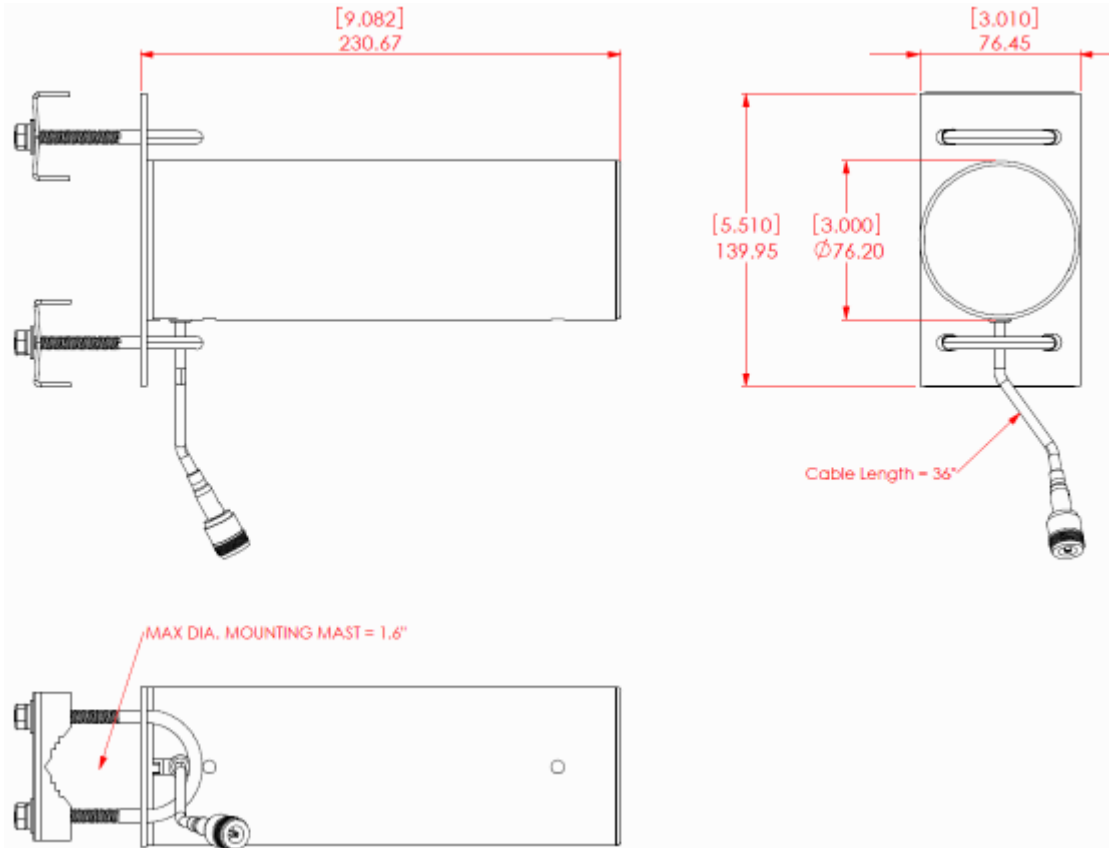

Type	Yagi
Frequency	4900-5800
Max/Typ Gain (dBi)	10.5/8.5
Polarization	Linear, Vertical
Azimuth	3dB Beamwidth: 31°
Elevation	3dB Beamwidth: 33°
Cable Length (in.)	N/A
Cable Type	ATX195
Connector Type	N Female
Weight	1.2 lbs
Plenum Antenna	No
Plenum Cable	No
Outdoor Rated	Yes

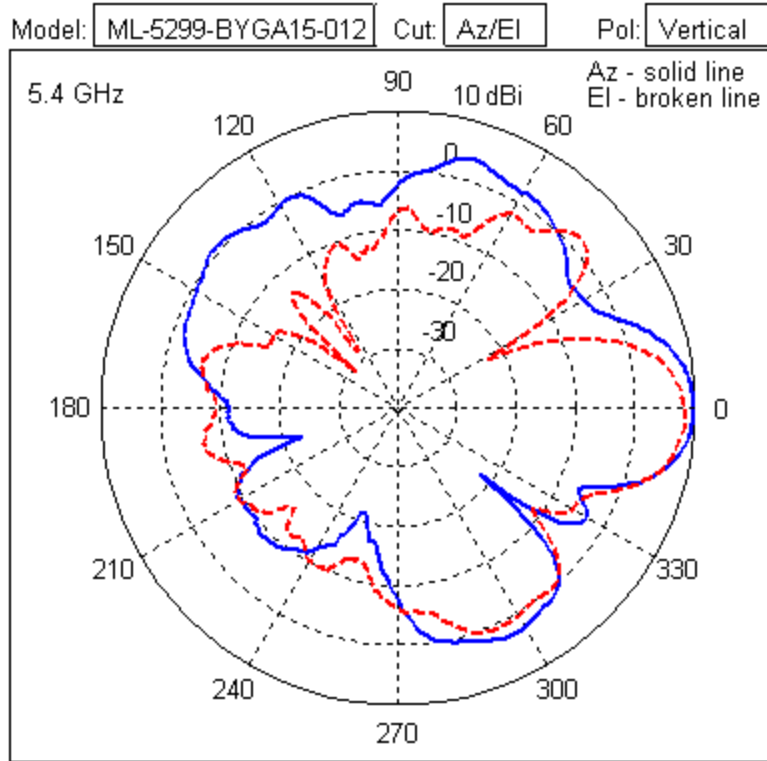

4.1.8 ML-5299-HPA5-01 Outdoor Dipole Omni N-Male

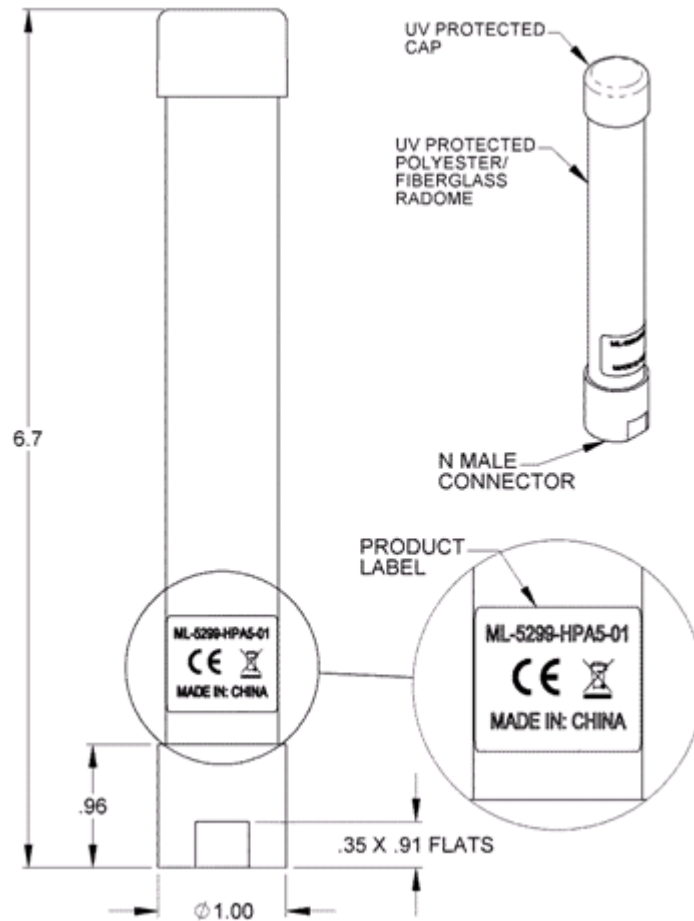

Type	Dipole Omni
Frequency	4900-5800
Gain (dBi)	5.6
Polarization	Linear, Vertical
Azimuth	3dB Beamwidth: 360°
Elevation	3dB Beamwidth: 22°
Cable Length (in.)	n/a
Cable Type	n/a
Connector Type	N-Type Male
Weight	73.8 grams
Plenum Antenna	No
Plenum Cable	n/a
Outdoor Rated	Yes

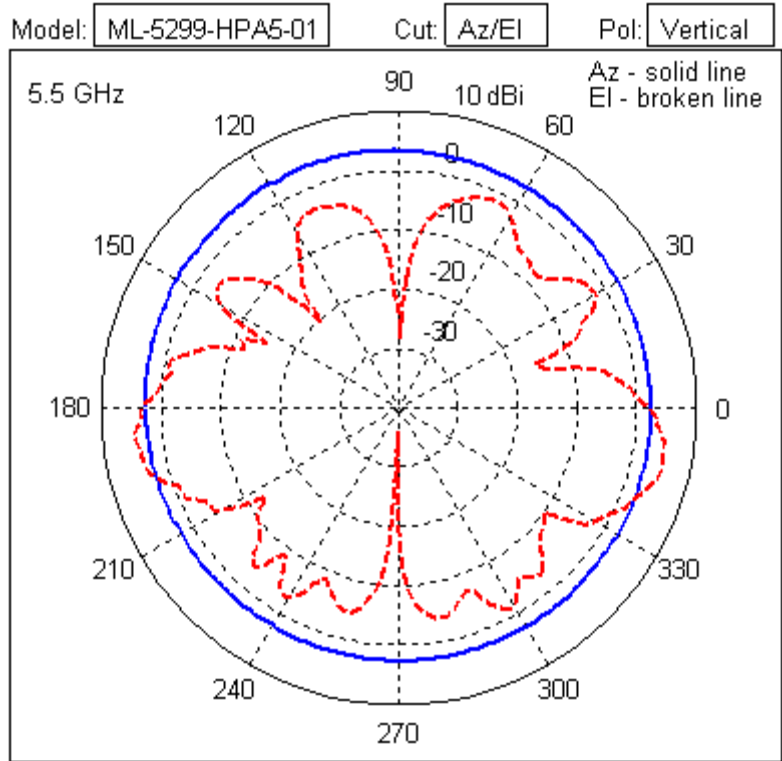

4.1.9 ML-5299-HPA10-01 Outdoor Dipole Omni N-Male

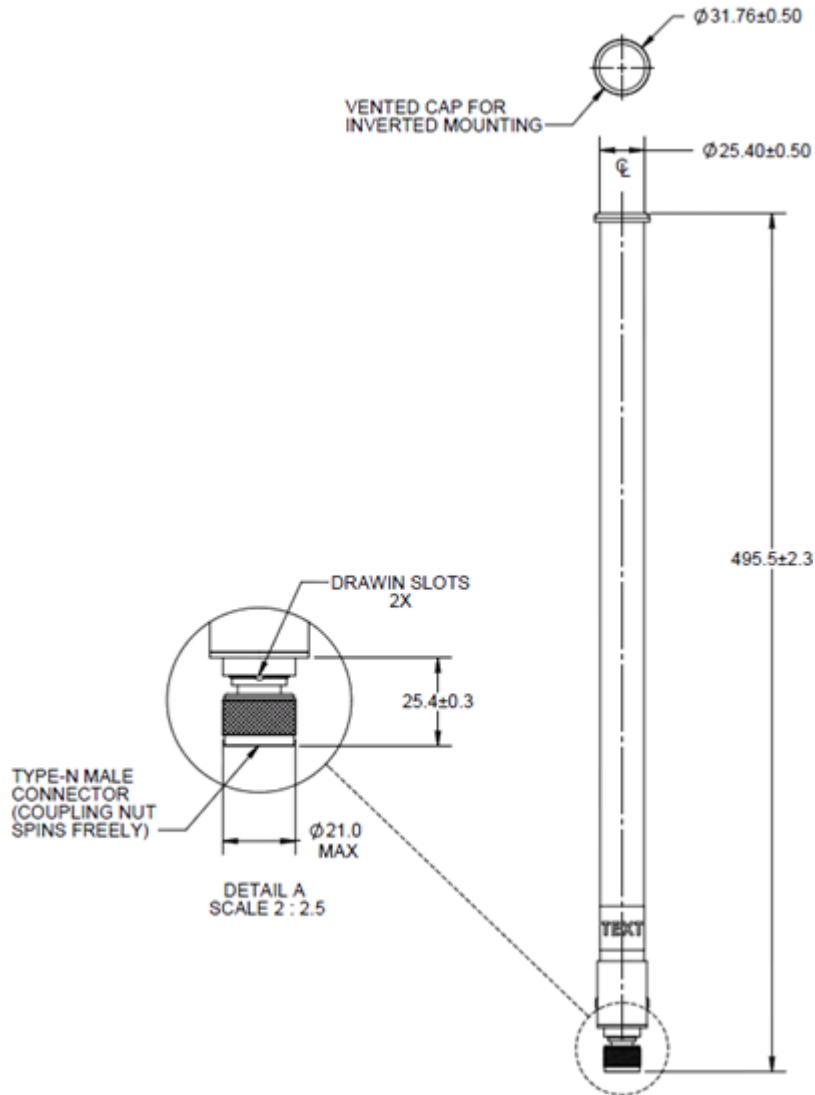

Type	Dipole Omni
Frequency	4900-5800
Gain (dBi)	10.5
Polarization	Linear, Vertical
Azimuth	3dB Beamwidth: 360°
Elevation	3dB Beamwidth: 8°
Cable Length (in.)	n/a
Cable Type	n/a
Connector Type	N-Type Male
Weight	0.4 lbs
Plenum Antenna	No
Plenum Cable	n/a
Outdoor Rated	Yes

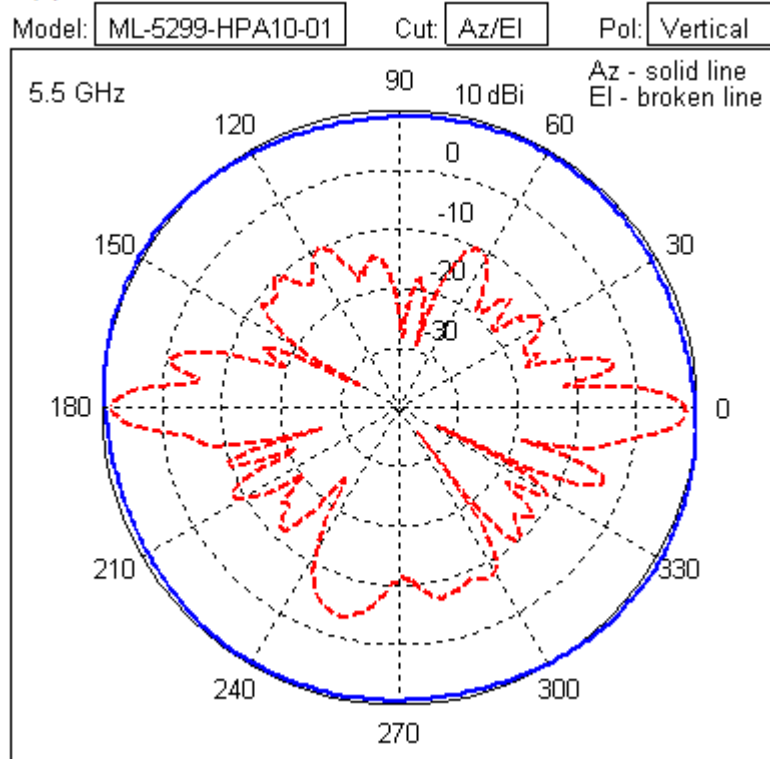

2.4GHz - 5.2GHz Dual Band Antenna Suite

5.1 Supported 802.11a/b/g/n Dual Band Antennas

Motorola Solutions supports several 2.4GHz - 5.2GHz Dual Band antennas to suit the requirements of your unique access point or access port deployment. Check the Motorola Solutions Web site periodically, as newly supported 2.4GHz - 5.2GHz Dual Band antennas will be added to this document as they are released. For more information, go to <http://supportcentral.motorola.com/support/product/manuals.do>.

For detailed information on supported 2.4GHz - 5.2GHz Dual Band antenna models, refer to:

- *ML-2452-APA2-01 Indoor Dual Band Elbow Jointed Dipole: RP-SMA Male (Black) ML-2452-APA2-02 Indoor Dual Band Elbow Jointed Dipole: RP-SMA Male (White)*
- *ML-2452-PNA5-01R Dual Band Directional Panel: Connector Type N-Male*
- *ML-2452-PNA7-01R Dual Band Panel: Connector Type N-Male*
- *ML-2452-PTA2M3X3-1 AP-7131 MIMO Facade: 1 IN, RPSMA*
- *ML-2452-PTA3M3-036 Ceiling Mount, Dual Band, MIMO Patch: RPSMA*
- *ML-2452-HPA5-036 Dipole, RP-SMA-Male*
- *ML-2452-PNL9M3-036 MIMO Dual Band Selector, RP-SMA Male*
- *ML-2452-APAG2A1-01 Dipole, RP-SMA Male (Black) ML-2452-APAG2A1-02 Dipole, RP-SMA Male (White)*
- *ML-2452-HPAG4A6-01 Outdoor Dipole Omni N-Male*
- *ML-2452-HPAG5A8-01 Outdoor Dipole Omni N-Male*
- *ML-2452-PTA6X6-036 Indoor dual-band MIMO Omni Array, RP-SMA Male*
- *ML-2452-HPA6X6-036 802.11ABG 6-Port Omni Dipole Array, Type N Male x6*
- *ML-2452-PTA2M2-036 802.11ABG 2-Port Patch Array, RP-SMA Male*
- *ML-2452-PTA6M6-036 Six-Port Omnidirectional Panel, RP-SMA Male*

5.1.1 ML-2452-APA2-01 Indoor Dual Band Elbow Jointed Dipole: RP-SMA Male (Black)
ML-2452-APA2-02 Indoor Dual Band Elbow Jointed Dipole: RP-SMA Male (White)

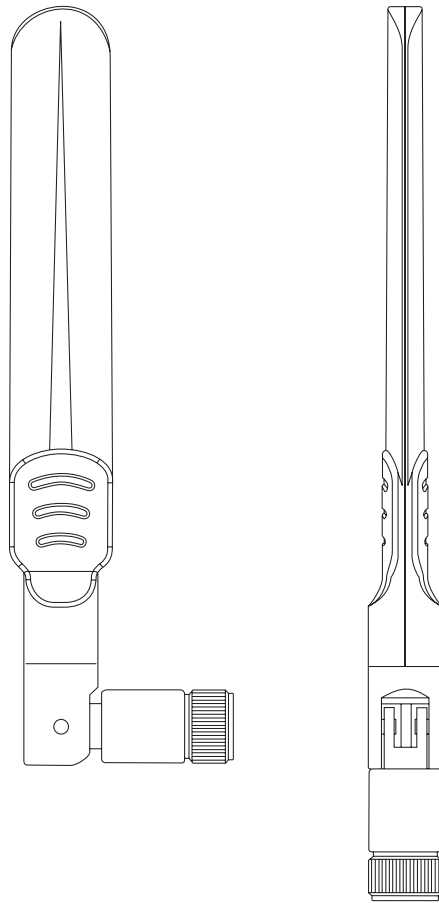

Type	Dipole
Frequency	2400-2500/5150-5850 MHz
Gain (dBi)	3.0 / 5.0
Polarization	Linear, Vertical
Azimuth	3dB Beamwidth: 360°
Elevation	3dB Beamwidth: 35°
Cable Length (in.)	N/A
Cable Type	N/A
Connector Type	RP-SMA Male
Weight	0.7 oz
Plenum Antenna	No
Plenum Cable	N/A
Outdoor Rated	No

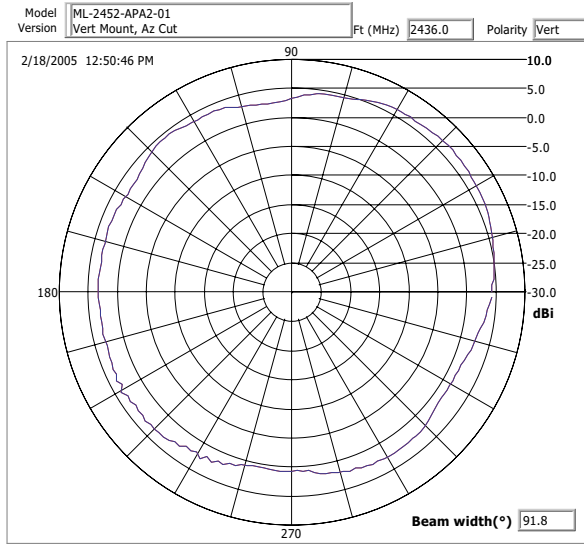

Azimuth Pattern

802.11b Band

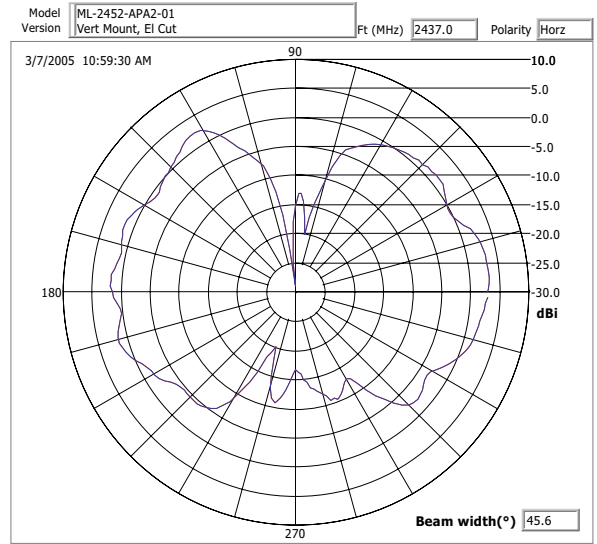

Elevation Pattern

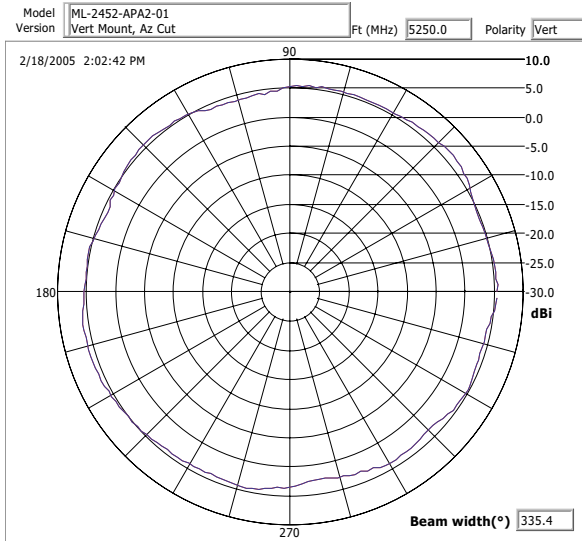

Azimuth Pattern

802.11a Band

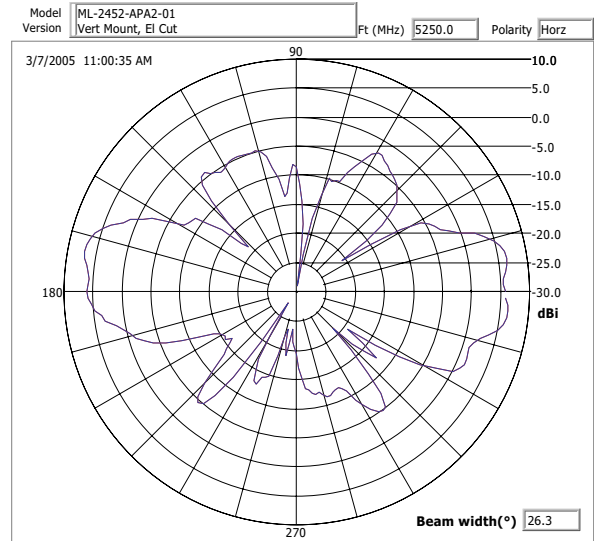

Elevation Pattern

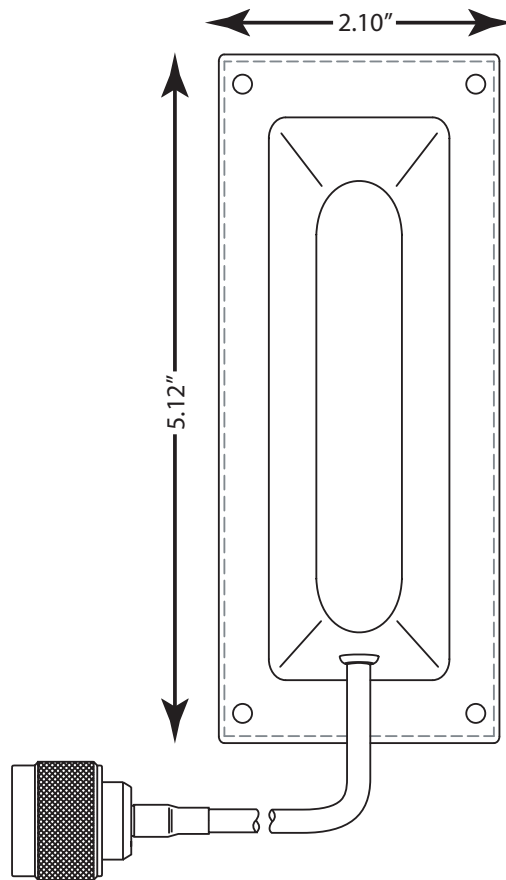
5.1.2 ML-2452-PNA5-01R Dual Band Directional Panel: Connector Type N-Male

Type	Panel
Frequency	2400-2500/4900-5900 MHz
Gain (dBi)	5.5/6.0
Polarization	Linear, Vertical
Azimuth	3dB Beamwidth: 120°/ 120°
Elevation	3dB Beamwidth: 60°/ 60°
Cable Length (in.)	12
Cable Type	RG-58 Ultralink
Connector Type	Type N Male
Weight	0.2 lb
Plenum Antenna	No
Plenum Cable	Yes
Outdoor Rated	Yes
Storage Temp Range (C)	-30 / +70
Operation Temp Range (C)	-30 / +70

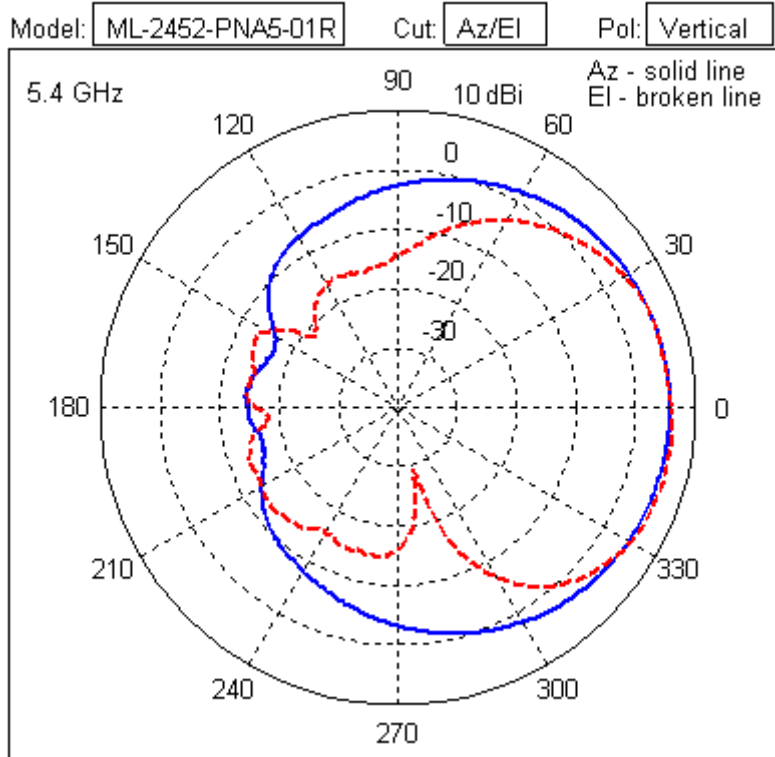
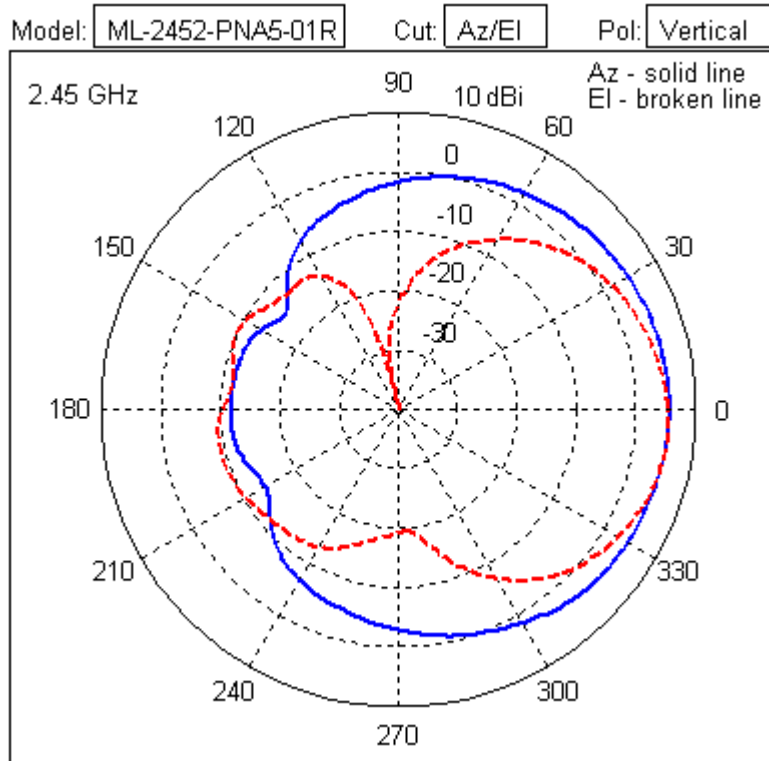

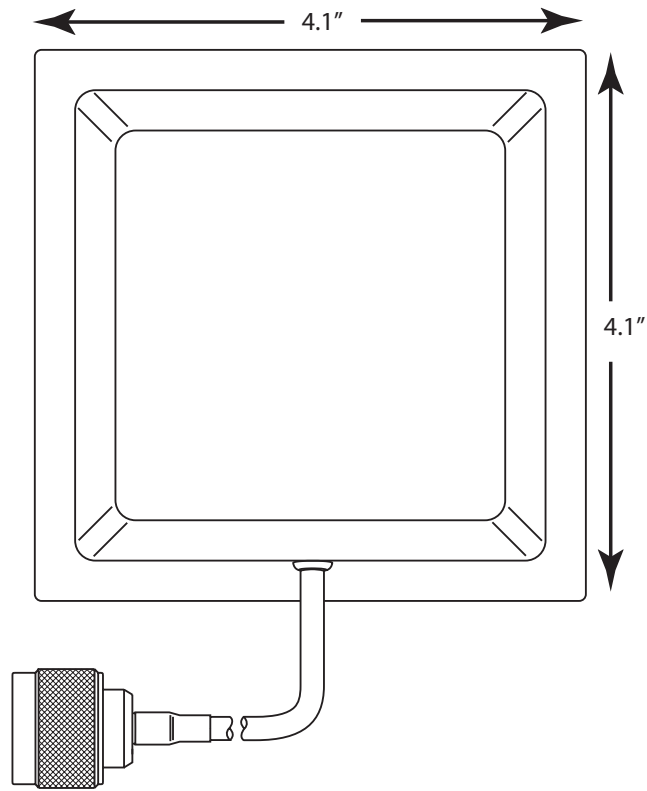
5.1.3 ML-2452-PNA7-01R Dual Band Panel: Connector Type N-Male

Type	Panel
Frequency	2400-2500/4900-5900 MHz
Gain (dBi)	8.0/12.0
Polarization	Linear, Vertical
Azimuth	3dB Beamwidth: 68° / 52°
Elevation	3dB Beamwidth: 66° / 60°
Cable Length (in.)	12
Cable Type	RG-58 Ultralink
Connector Type	Type N Male
Weight	0.5 lb
Plenum Antenna	No
Plenum Cable	Yes
Outdoor Rated	Yes
Storage Temp Range (C)	-40 / +85
Operation Temp Range (C)	-30 / +70

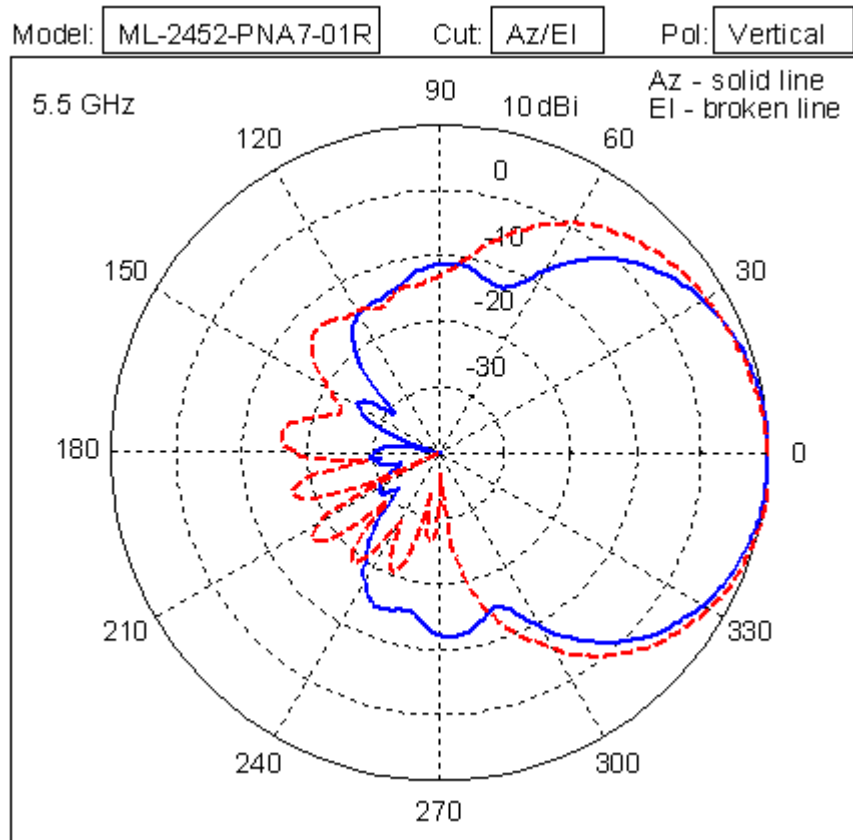
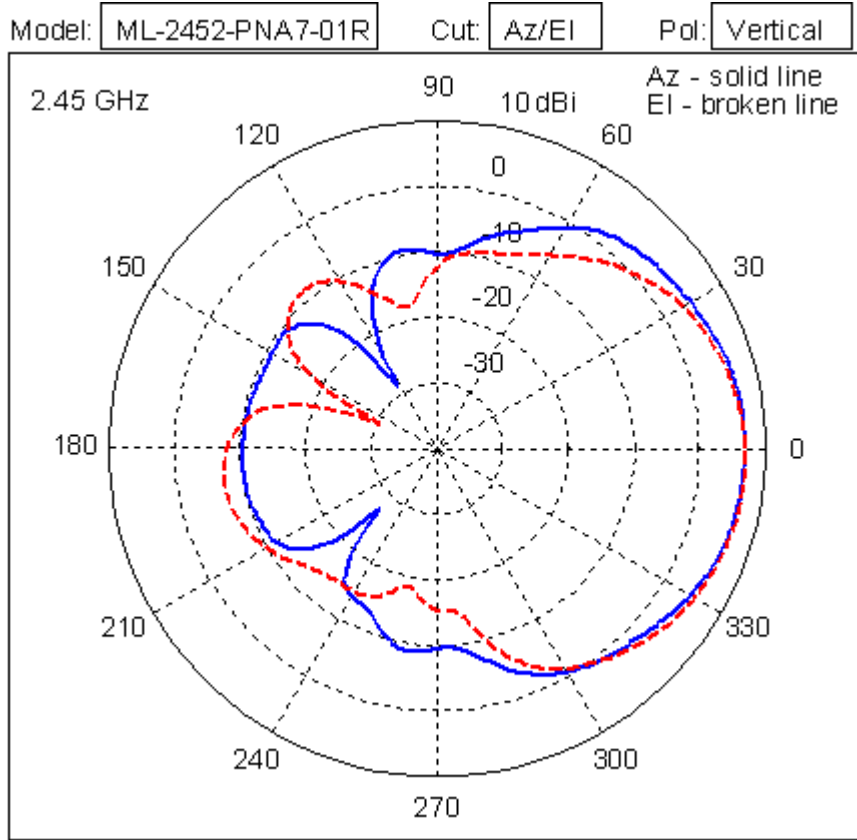

5.1.4 ML-2452-PTA2M3X3-1 AP-7131 MIMO Facade: 1 IN, RPSMA

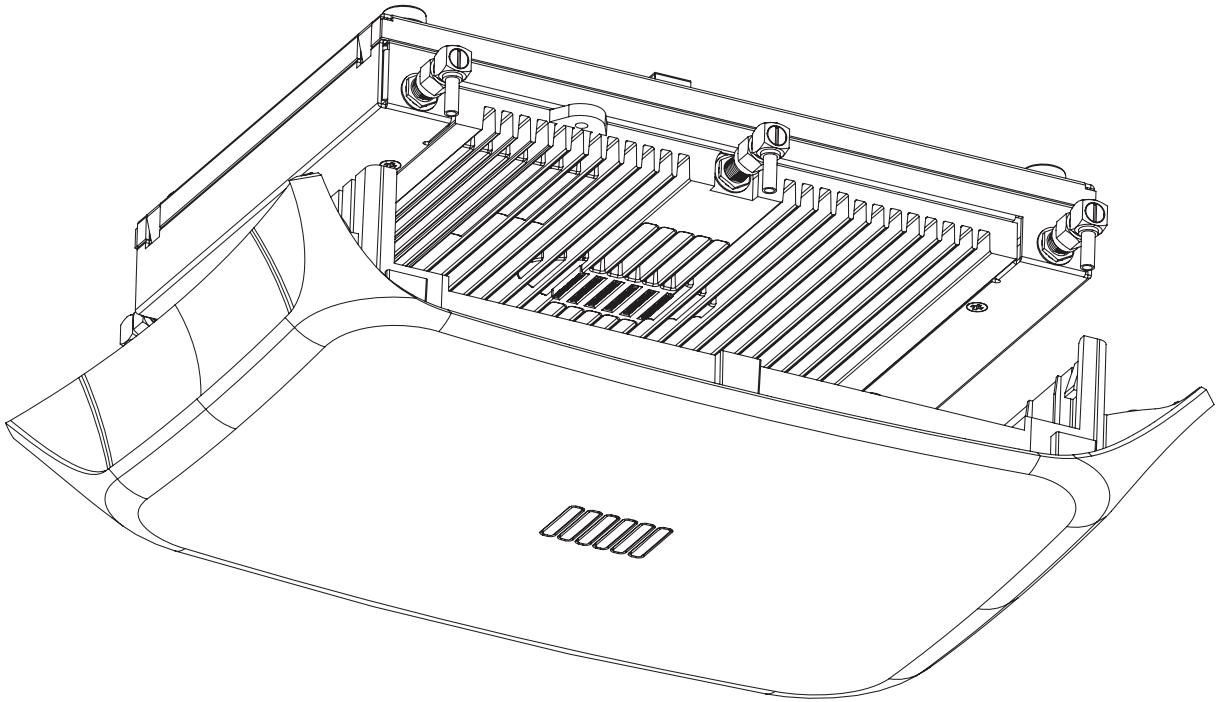

NOTE: ML-2452-PTA2M3x3-1 was formally released as Motorola Solutions part number ML-2452-APA2-FAC.

Type	Patch x 6 in snap-on facade
Frequency	2400-2500/4900-5990 MHz
Gain (dBi)	3.0 / 5.0
Polarization	Linear, Vertical
Azimuth	3dB Beamwidth: 360°
Elevation	3dB Beamwidth: 90° (southern hemisphere pattern)
Cable Length (in.)	Integrated into snap-on facade
Cable Type	1.20 mm coax
Connector Type	RP-SMA Male
Antenna Plenum Rated	No
Cable Plenum Rated	No
Outdoor Rated	No
Weight	0.79 lb

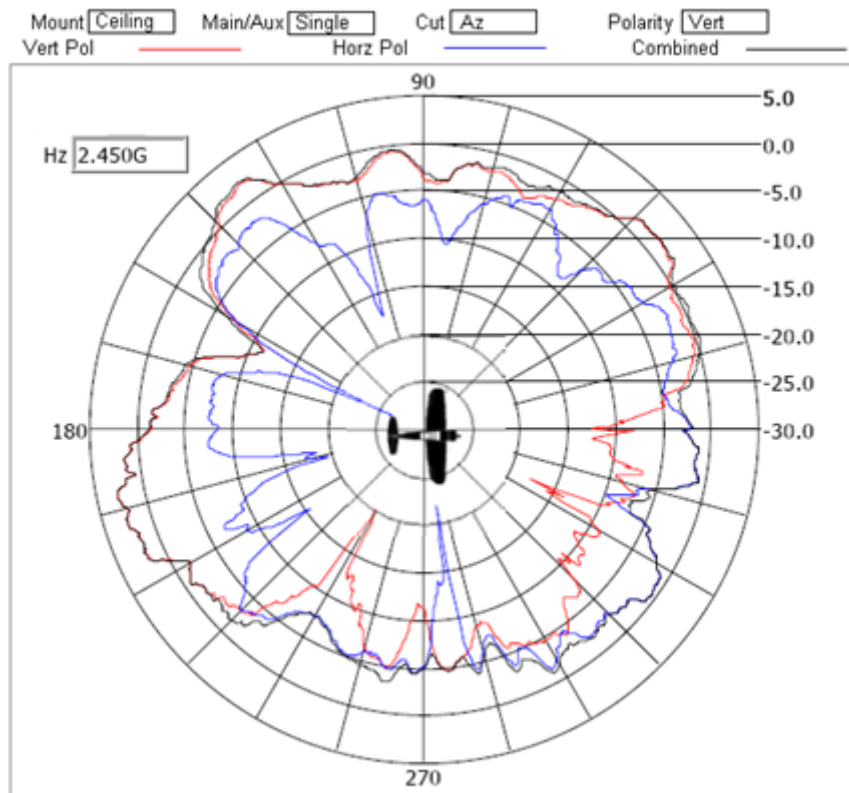

Azimuth Pattern

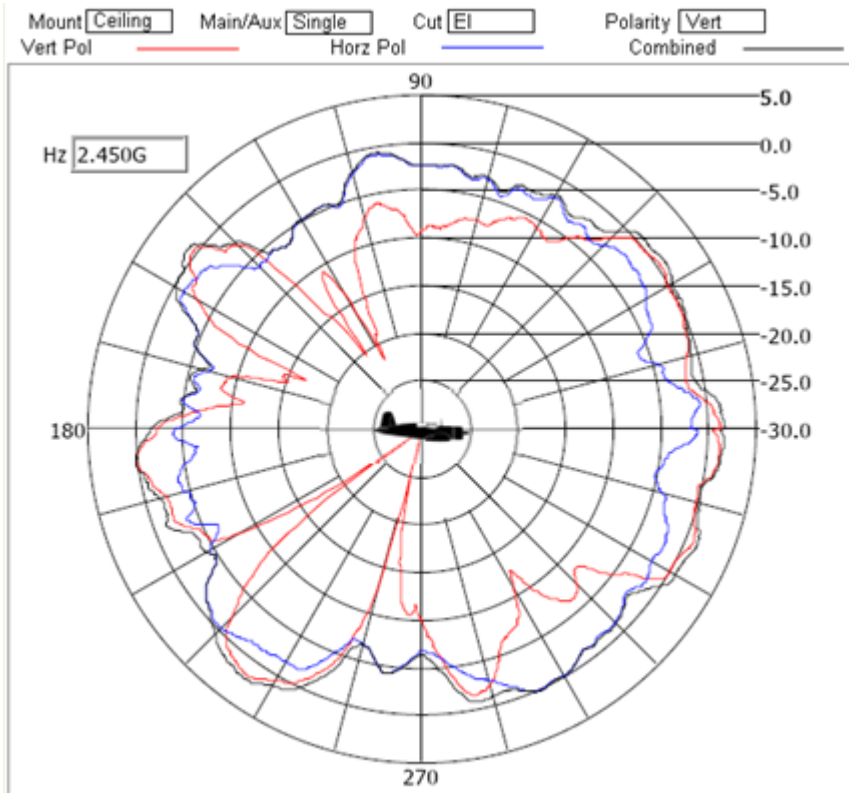

Elevation Pattern

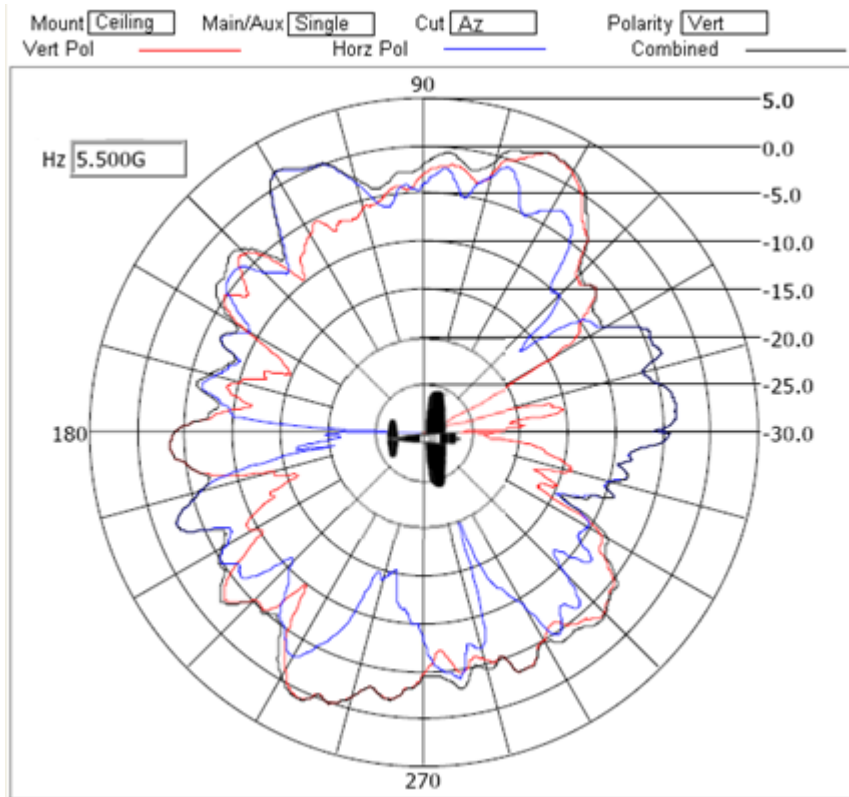

Azimuth Pattern

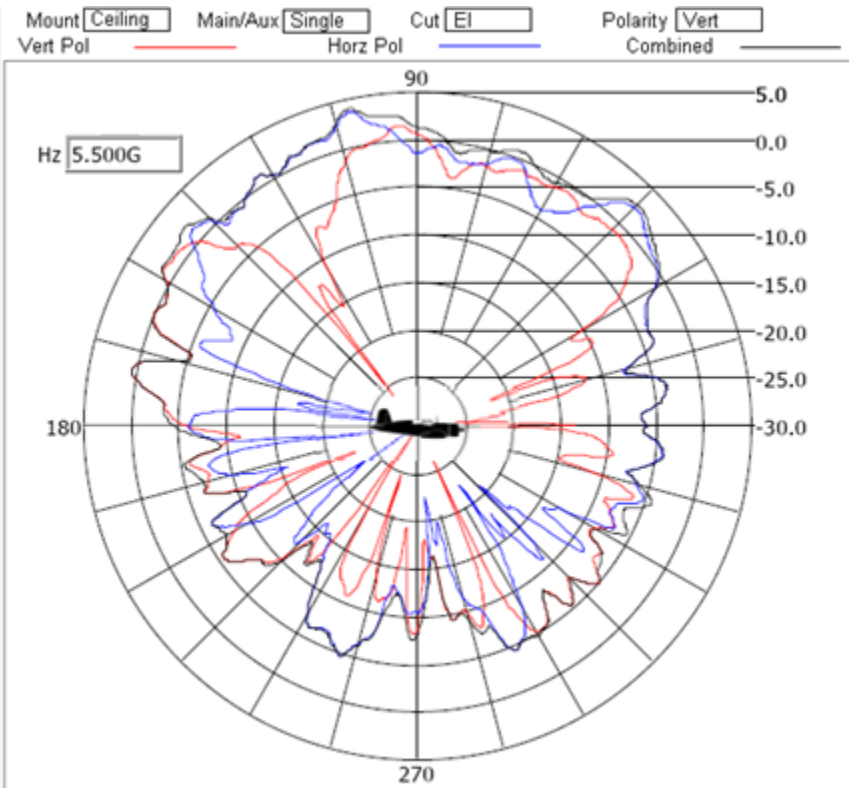

Elevation Pattern

5.1.5 ML-2452-PTA3M3-036 Ceiling Mount, Dual Band, MIMO Patch: RPSMA

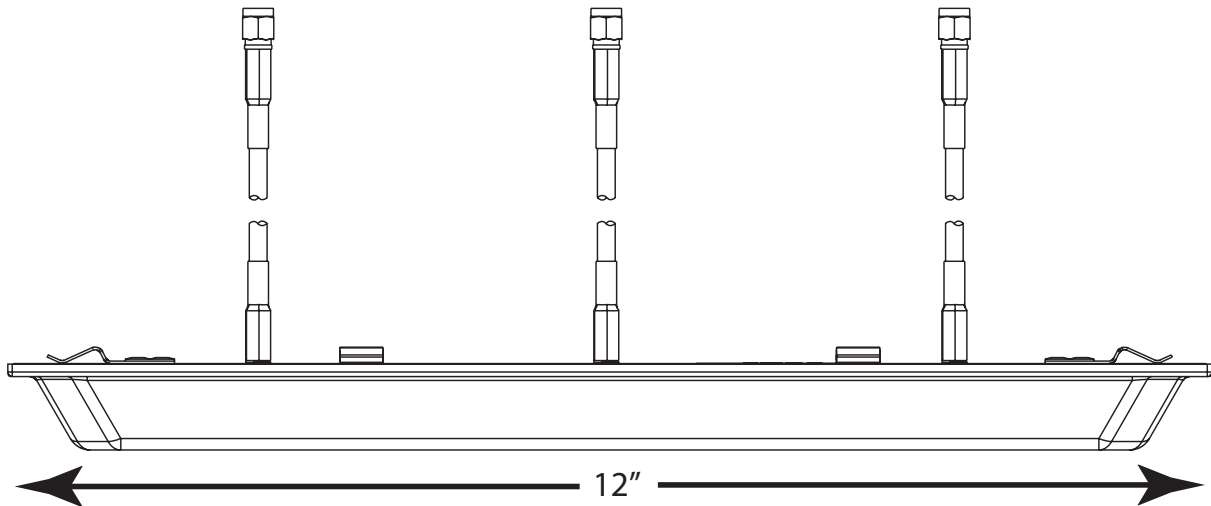

Type	Patch x 3
Frequency	2400-2500/4900-5990 MHz
Gain (dBi)	3.0 / 4.0
Polarization	Linear, Vertical
Azimuth	3dB Beamwidth: 360°
Elevation	3dB Beamwidth: 60° (southern hemisphere pattern)
Cable Length (in.)	60
Cable Type	RG-58 50 Ohm coax
Connector Type	RP-SMA Male
Antenna Plenum Rated	No
Cable Plenum Rated	Yes
Outdoor Rated	No
Weight	0.7 lb

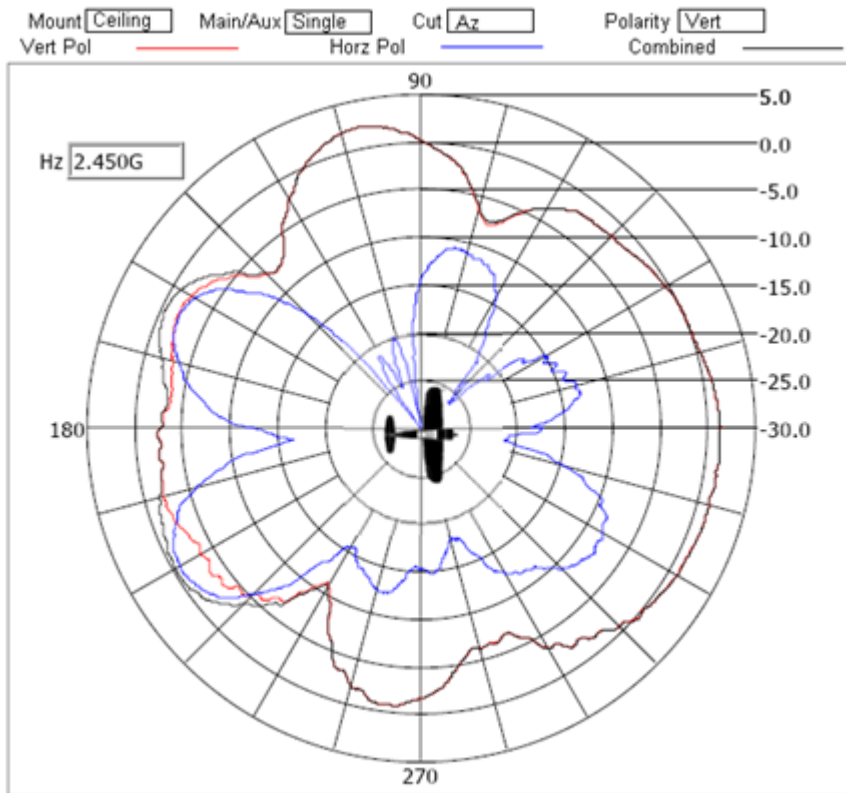

Azimuth Pattern

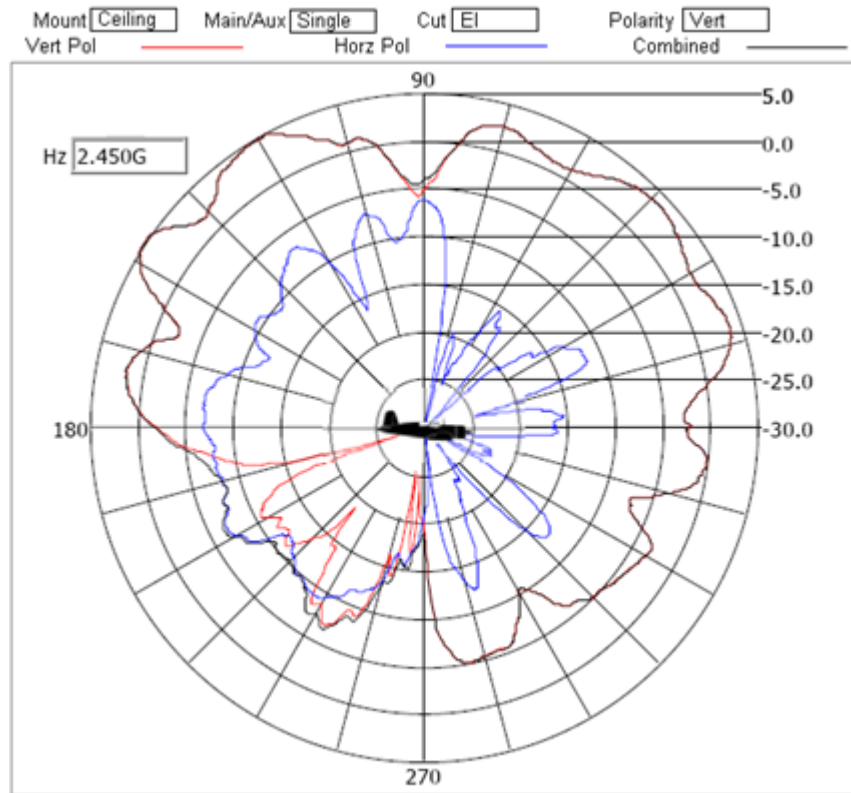

Elevation Pattern

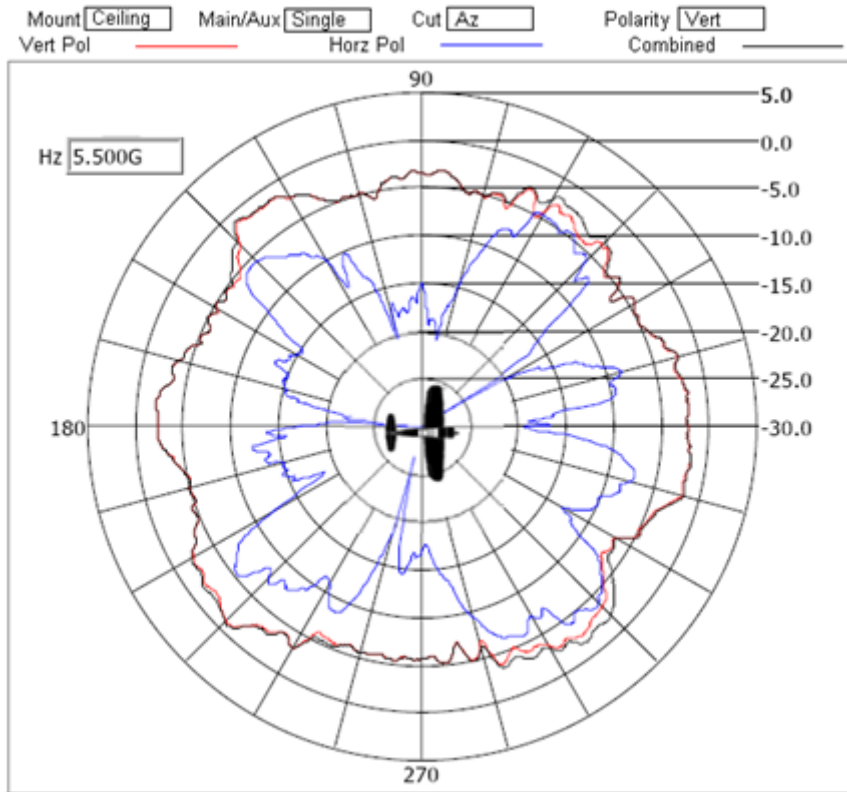

Azimuth Pattern

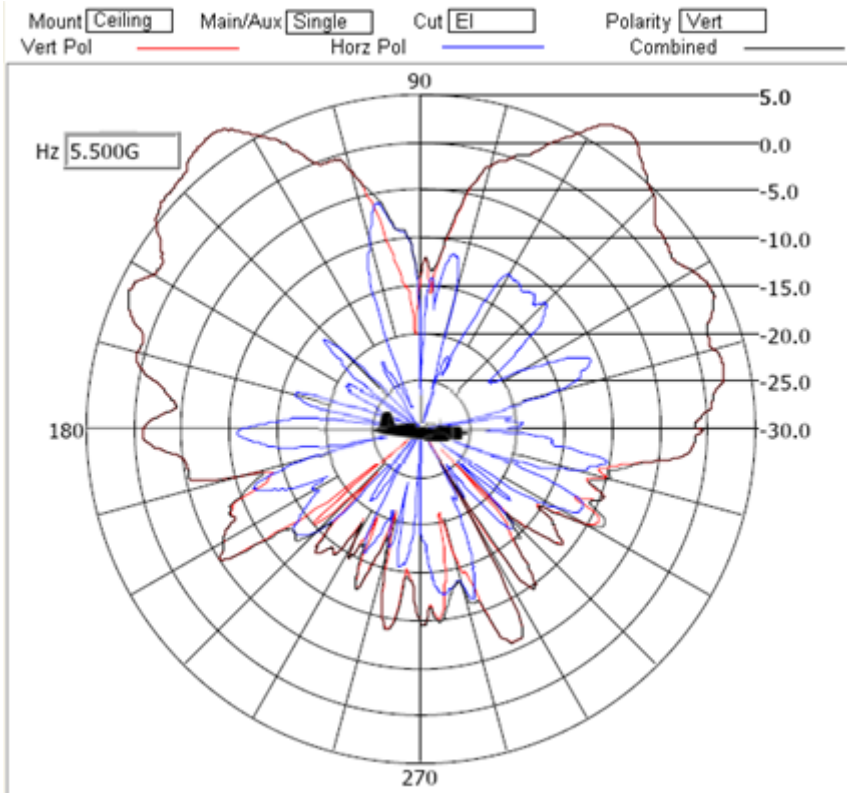

Elevation Pattern

5.1.6 ML-2452-HPA5-036 Dipole, RP-SMA-Male

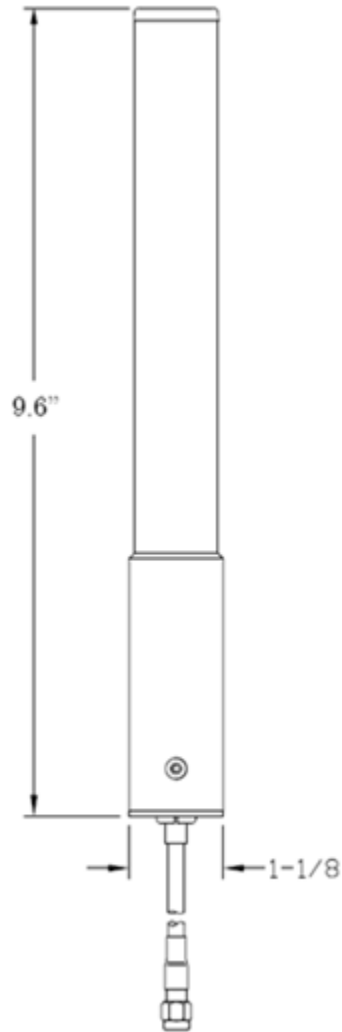

Type	Dipole
Frequency	2450-2500/5150-5875 MHz
Gain (dBi)	3.0 / 5.0
Polarization	Linear, Vertical
Azimuth	3dB Beamwidth: 360°
Elevation	3dB Beamwidth: 50°, 18°
Cable Length (in.)	36
Cable Type	RG-58 Plenum
Connector Type	RP-SMA Male
Antenna Plenum Rated	N/A

<i>Cable Plenum Rated</i>	N/A
<i>Outdoor Rated</i>	N/A
<i>Weight</i>	0.3 lbs

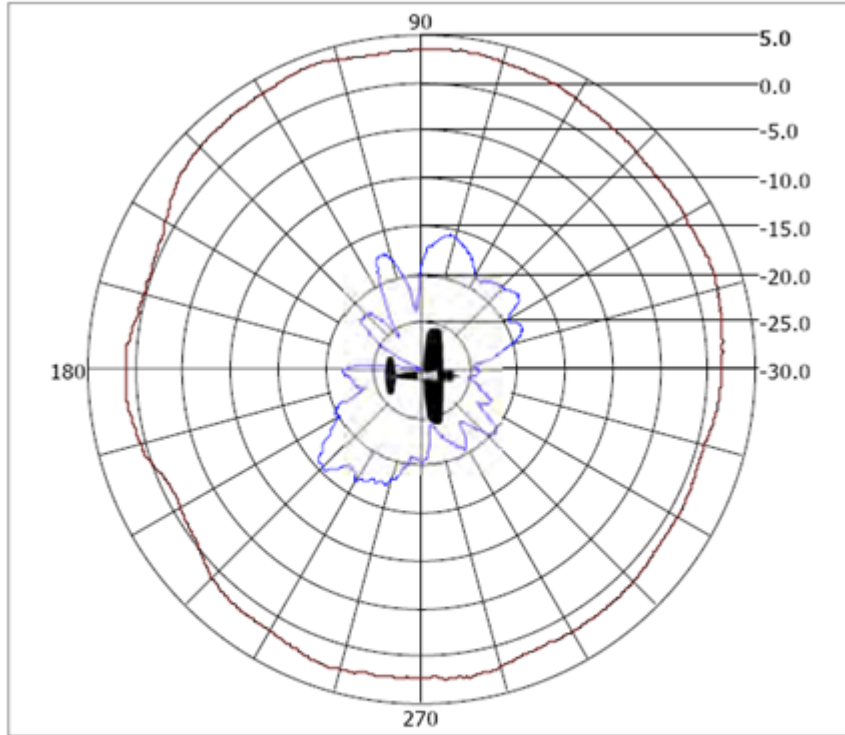

Azimuth Antenna Pattern

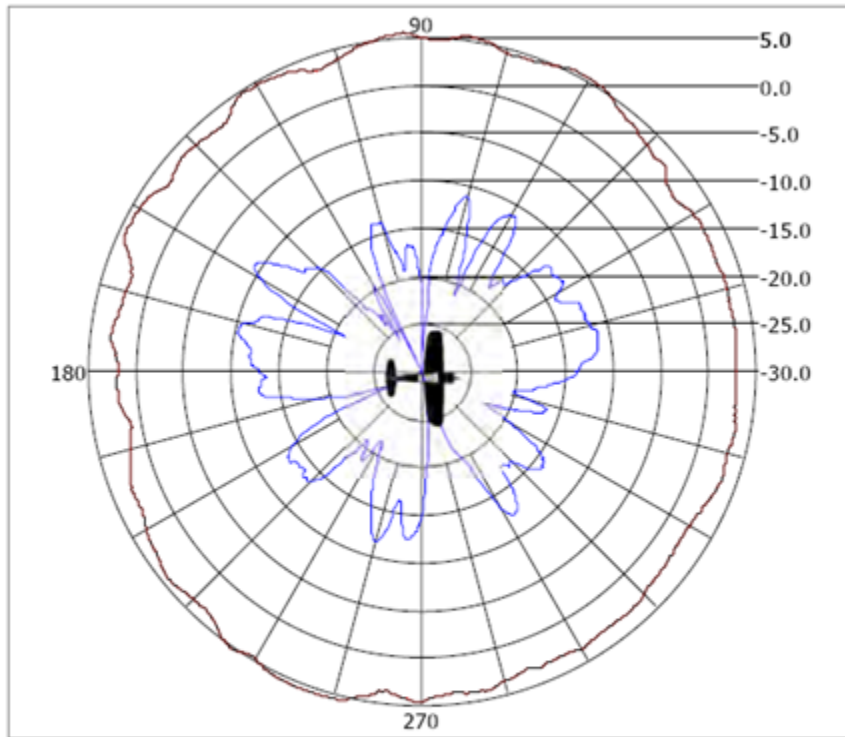

Azimuth Antenna Pattern

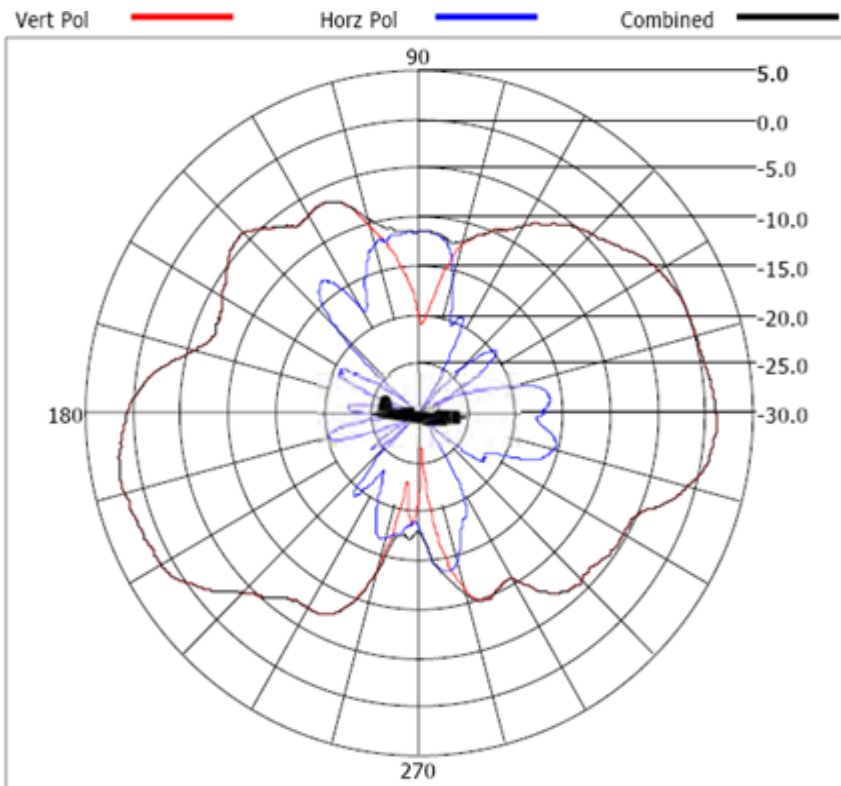

Elevation Antenna Pattern

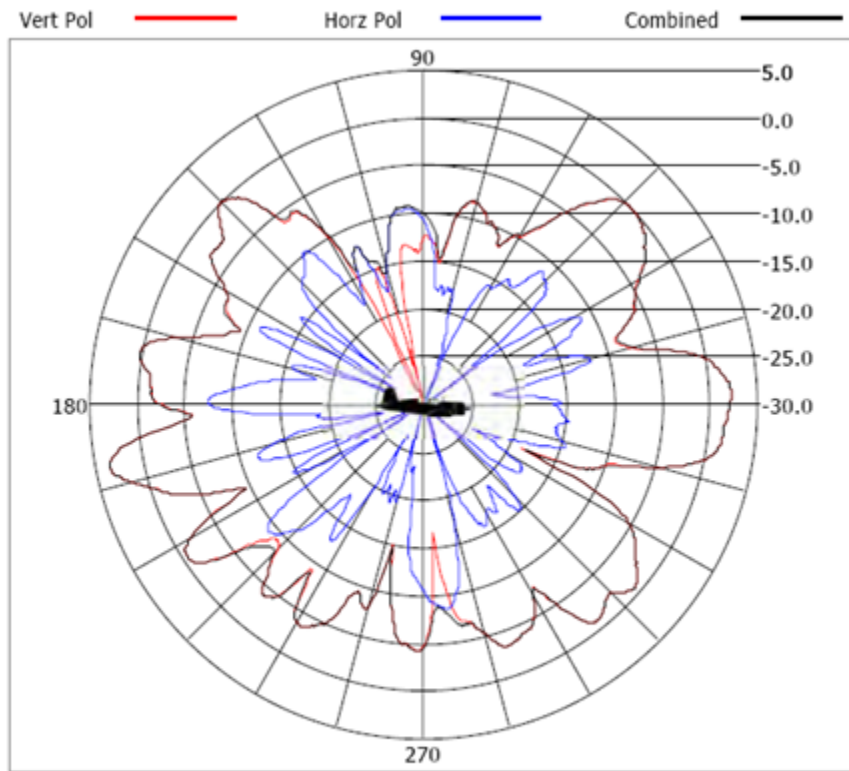

Elevation Antenna Pattern

5.1.7 ML-2452-PNL9M3-036 MIMO Dual Band Selector, RP-SMA Male

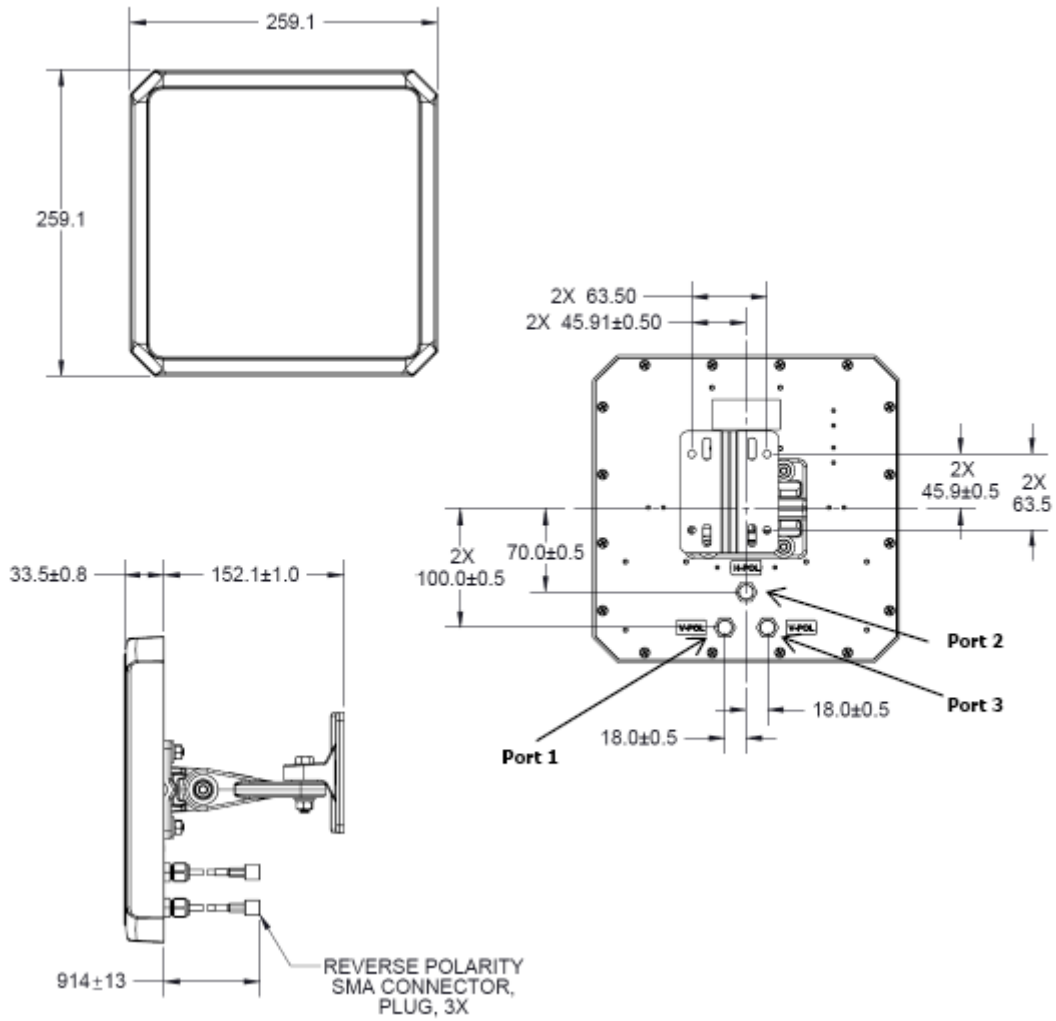

NOTE: The dimensions for the ML-2452-PNL9M3-036 model antenna are displayed in millimeters (mm) within the illustration above.

<i>Type</i>	MIMO Dual Band Selector
<i>Frequency</i>	2450-2500/5150-5875 MHz
<i>Gain (dBi)</i>	8.0 / 10.7
<i>Polarization</i>	Linear, Vertical
<i>Azimuth</i>	3dB Beamwidth: 75° / 55°
<i>Elevation</i>	3dB Beamwidth: 70° / 60°
<i>Cable Length (in.)</i>	36
<i>Cable Type</i>	Low Temperature Plenum
<i>Connector Type</i>	RP-SMA Male
<i>Antenna Plenum Rated</i>	N/A
<i>Cable Plenum Rated</i>	No
<i>Outdoor Rated</i>	Yes
<i>Weight</i>	1.81 lbs

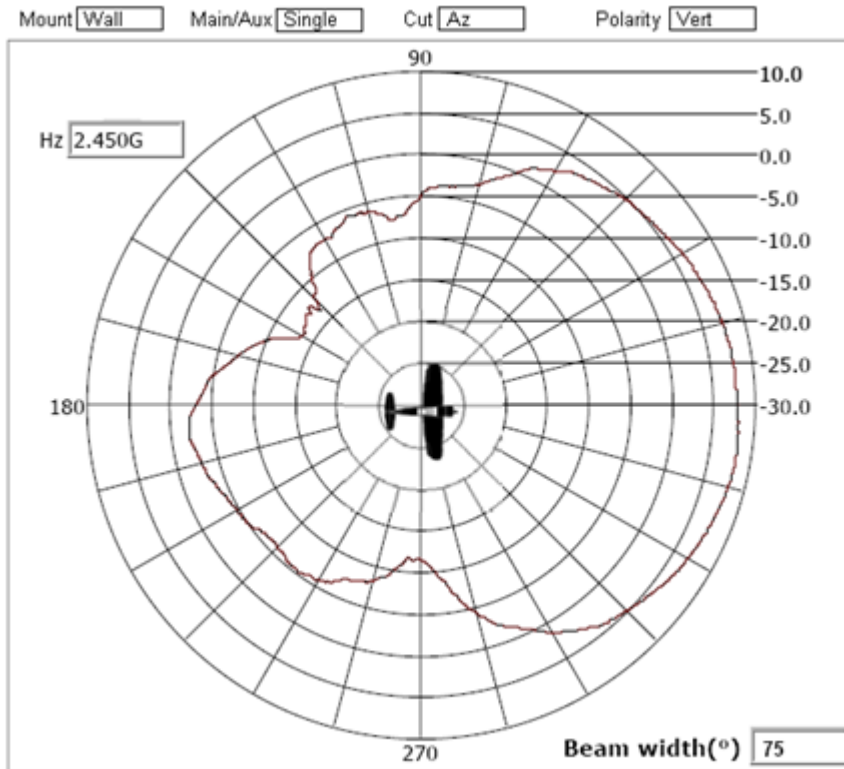

Port 1 Azimuth Pattern

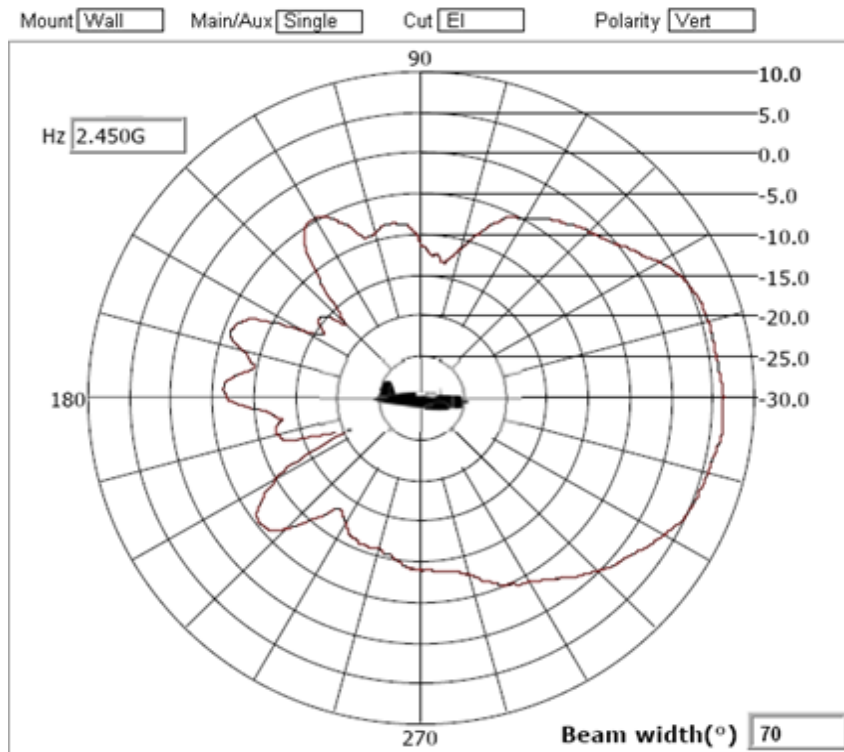

Port 1 Elevation Pattern

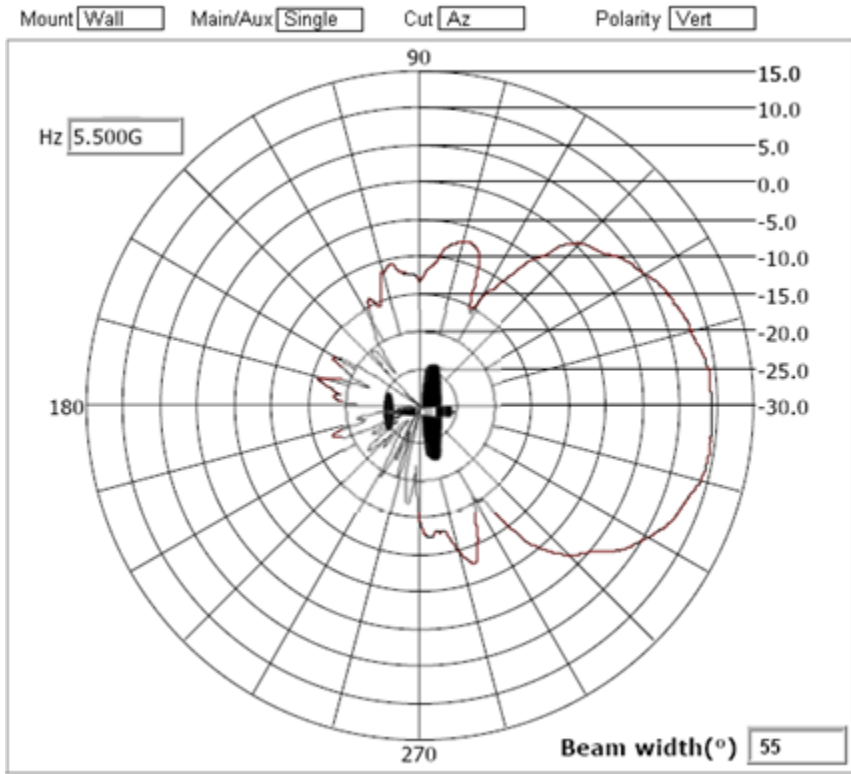

Port 1 Azimuth Pattern

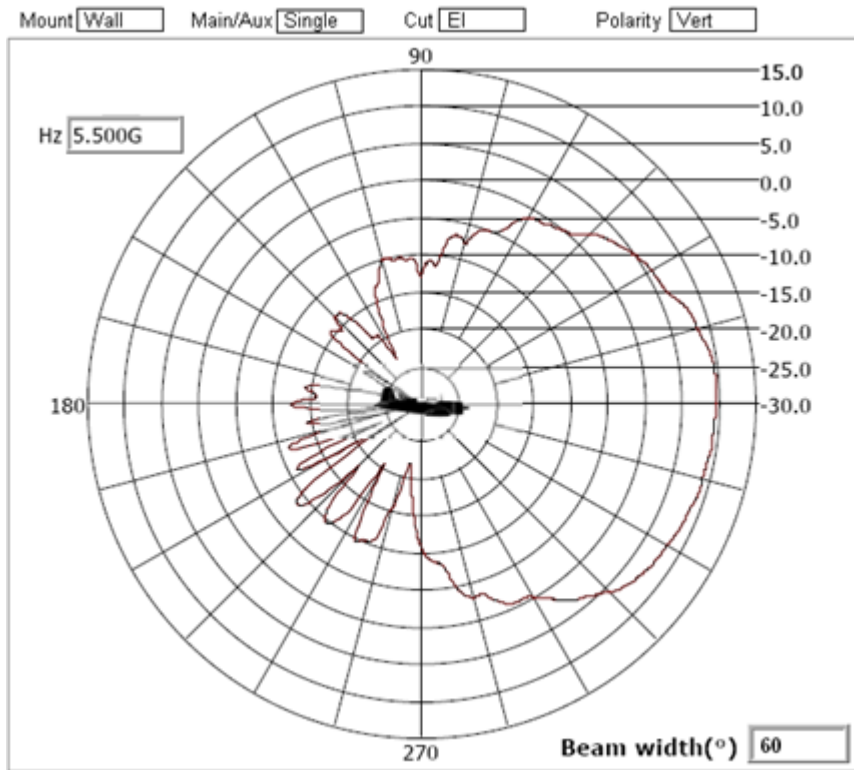

Port 1 Elevation Pattern

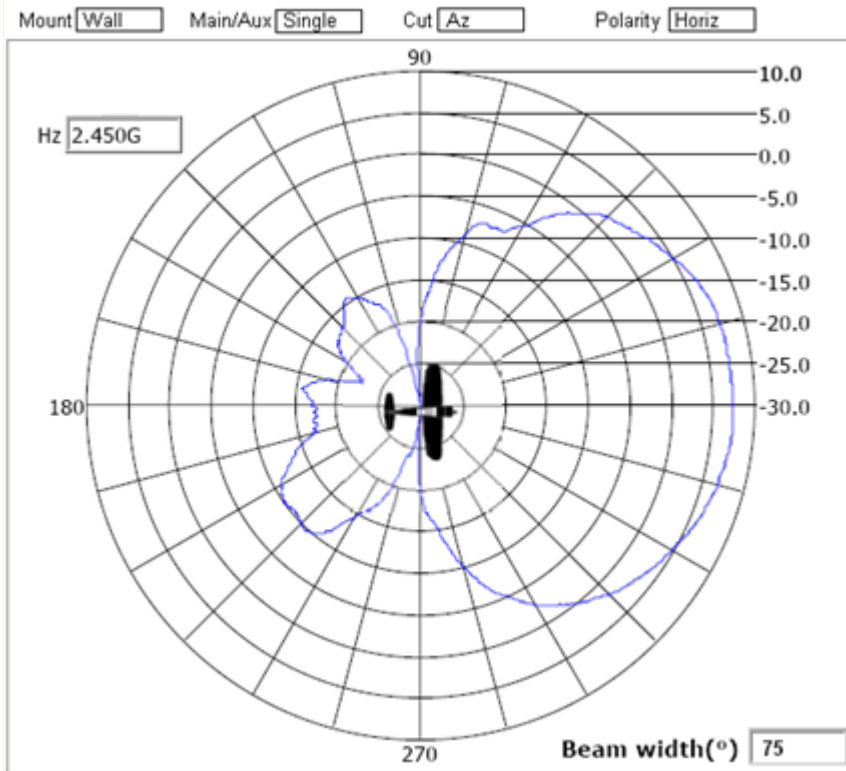

Port 2 Azimuth Pattern

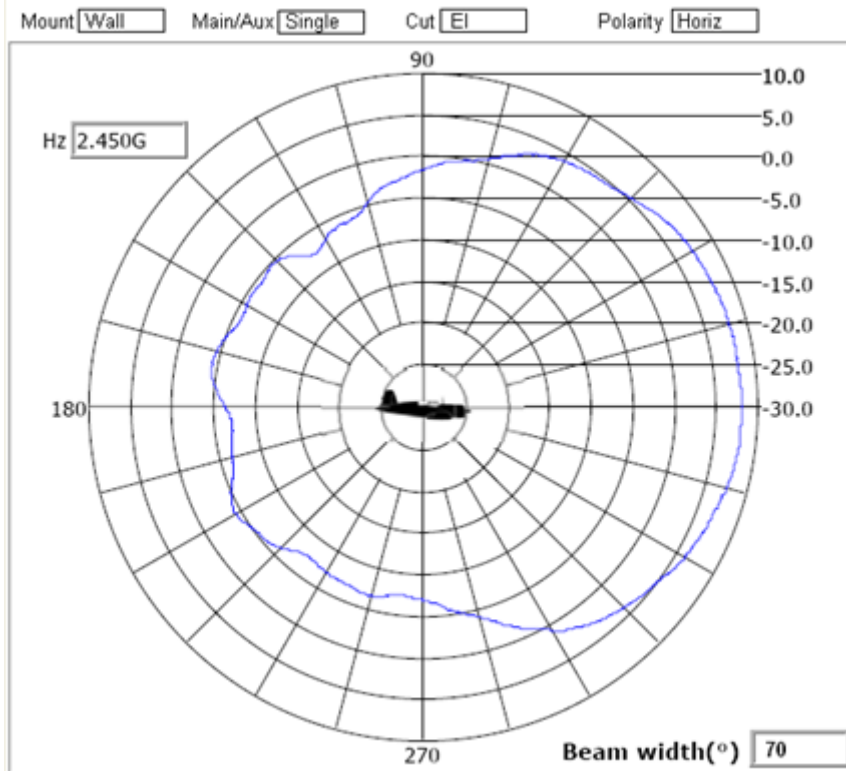

Port 2 Elevation Pattern

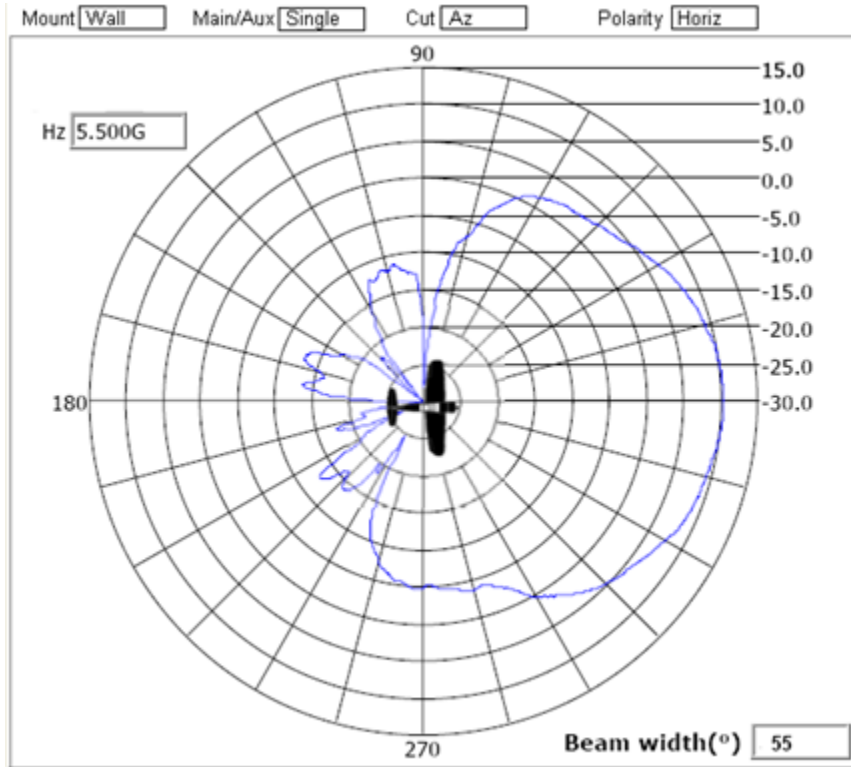

Port 2 Azimuth Pattern

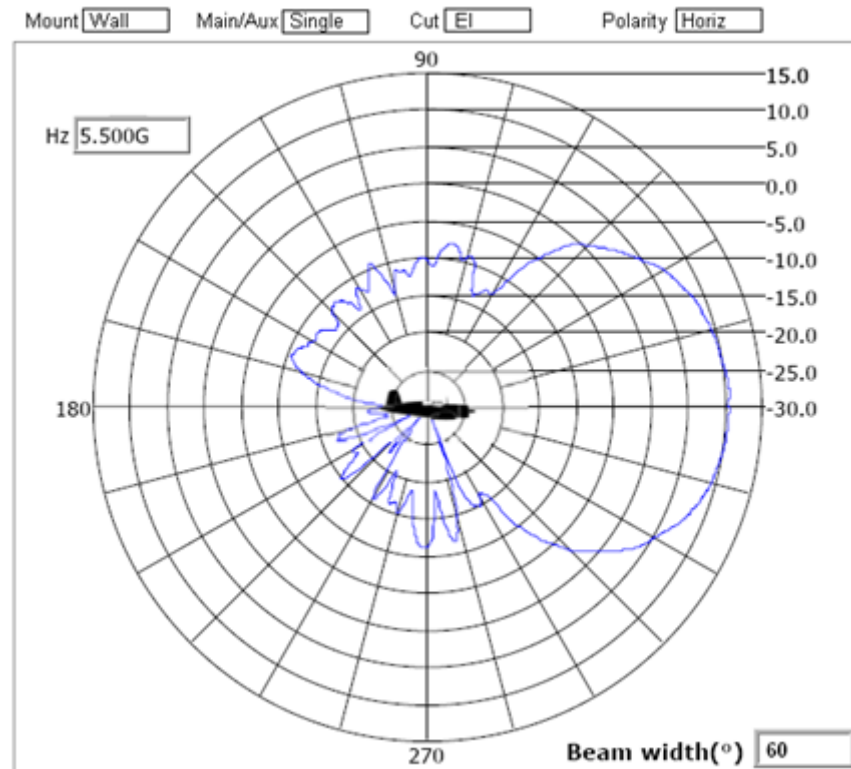

Port 2 Elevation Pattern

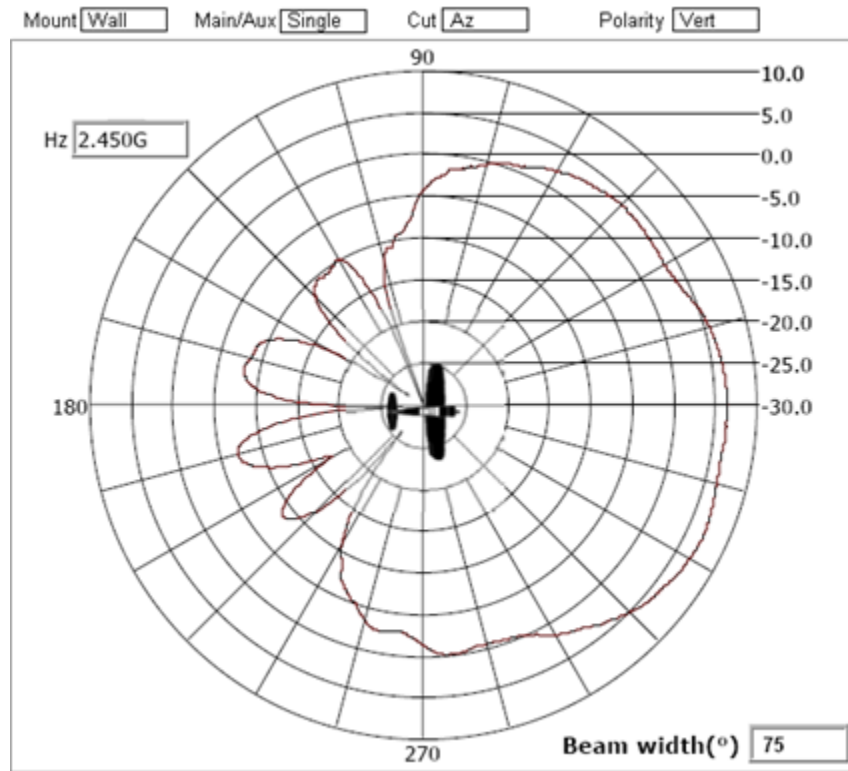

Port 3 Azimuth Pattern

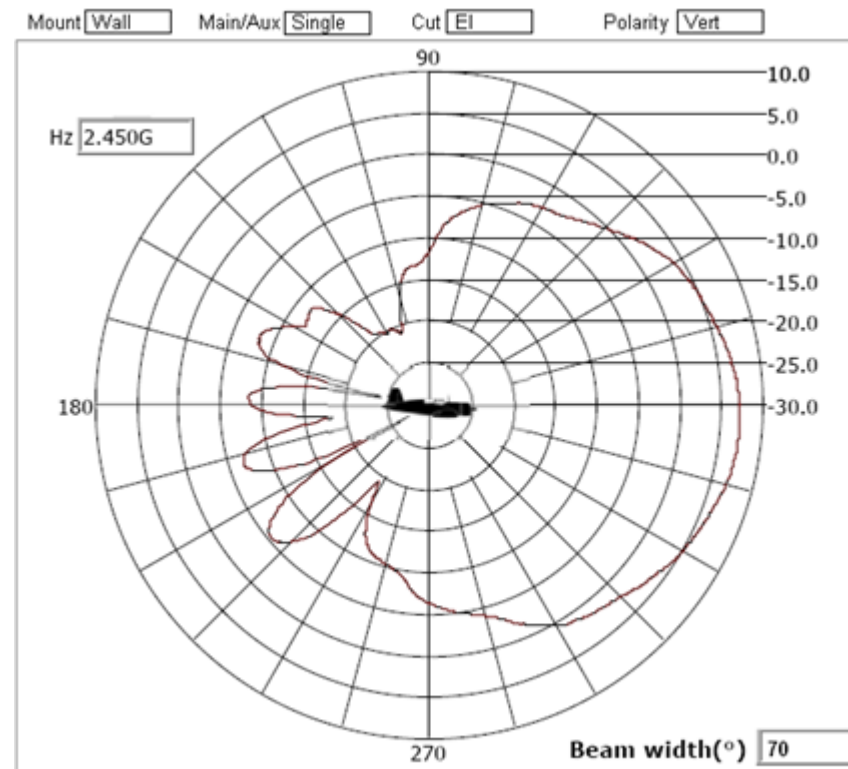

Port 3 Elevation Pattern

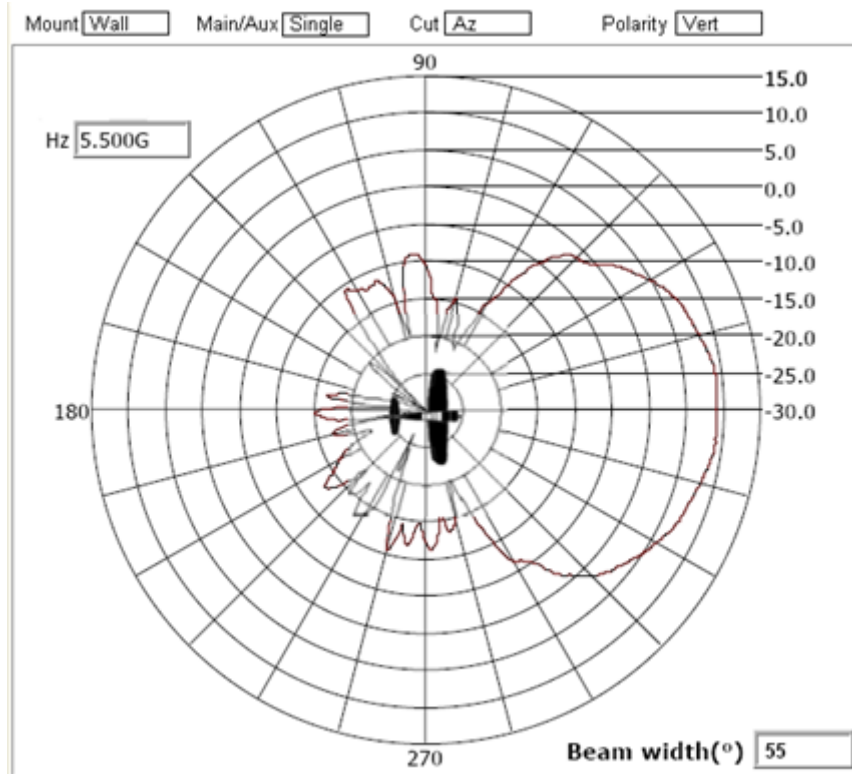

Port 3 Azimuth Pattern

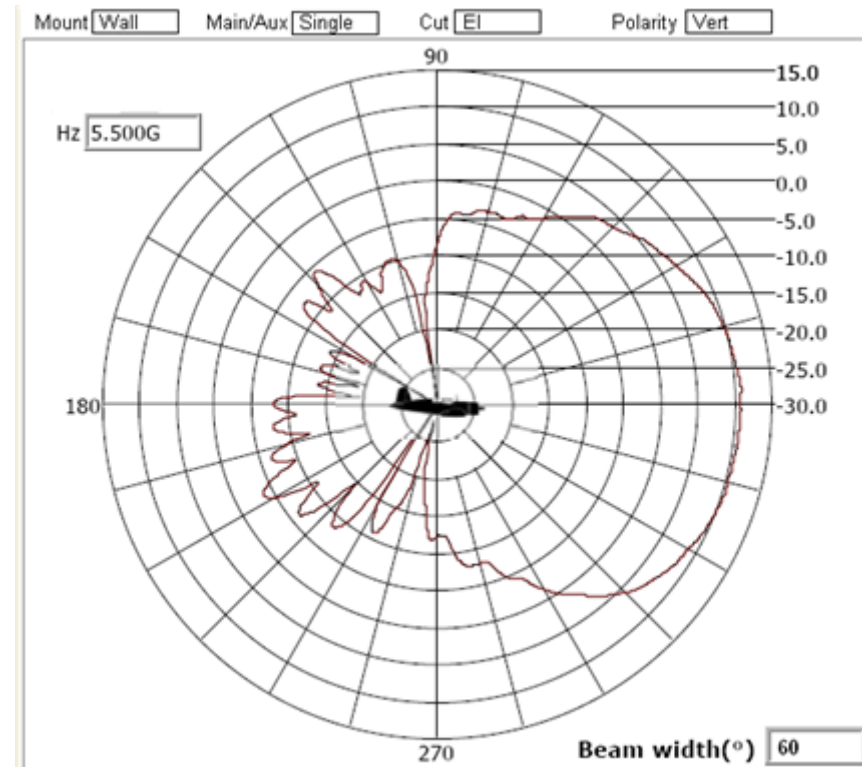

Port 3 Elevation Pattern

5.1.8 ML-2452-APAG2A1-01 Dipole, RP-SMA Male (Black)
ML-2452-APAG2A1-02 Dipole, RP-SMA Male (White)

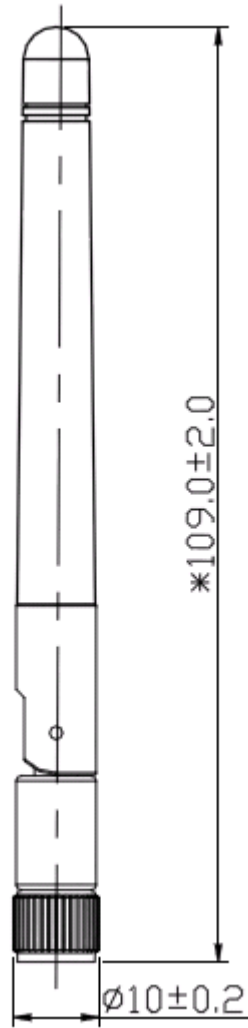

<i>Type</i>	Dipole
<i>Frequency</i>	2400-2500/4900-5900 MHz
<i>Gain (dBi)</i>	2.7 / 2.0
<i>Polarization</i>	Linear, Vertical
<i>Azimuth</i>	3 dB Beamwidth: 360 degrees
<i>Elevation</i>	3 dB Beamwidth: <= 60 degrees
<i>Cable Length (in.)</i>	N/A
<i>Cable Type</i>	N/A
<i>Connector Type</i>	RP-SMA Male
<i>Antenna Plenum Rated</i>	No
<i>Cable Plenum Rated</i>	No
<i>Outdoor Rated</i>	No
<i>Weight</i>	10 g

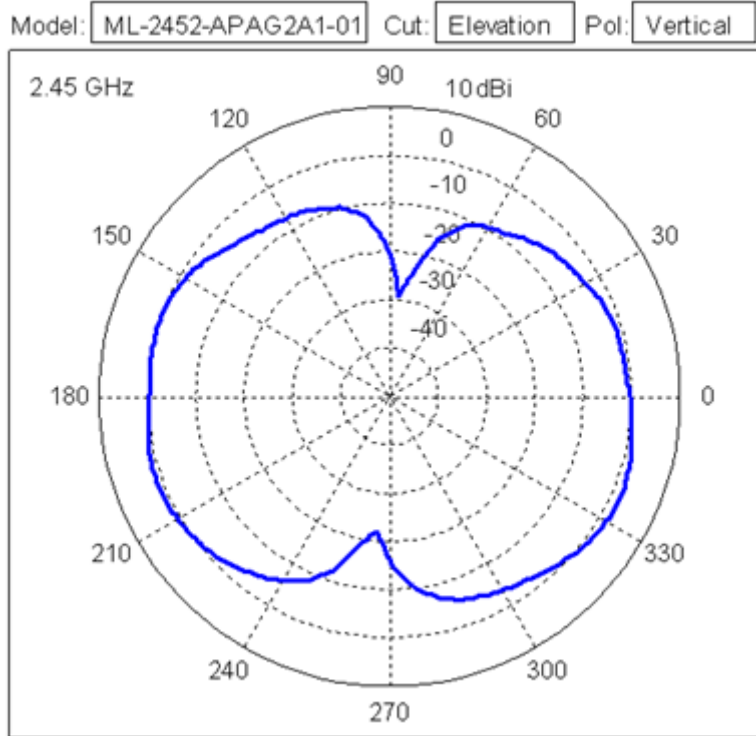
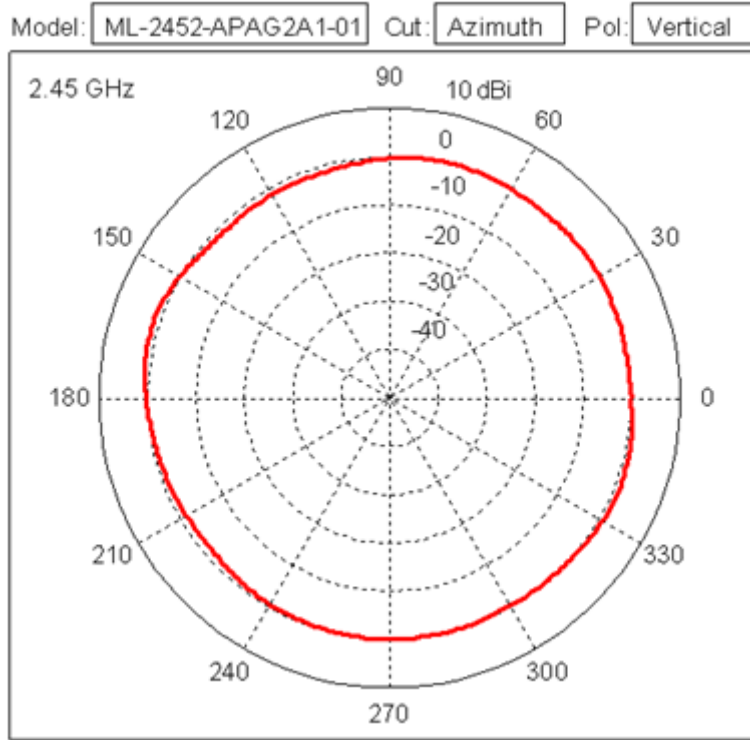

Model: Cut: Pol:

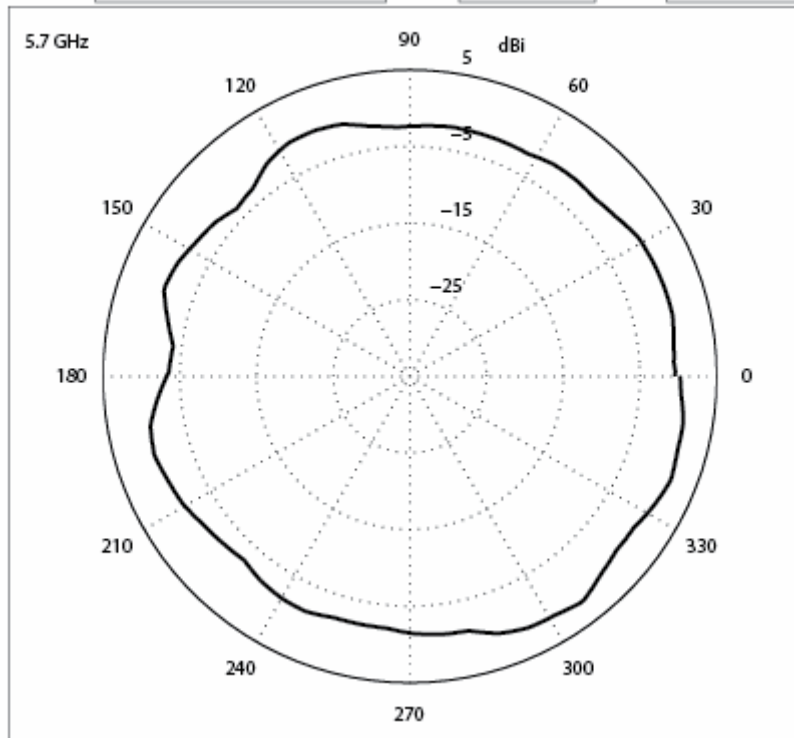

Model: Cut: Pol:

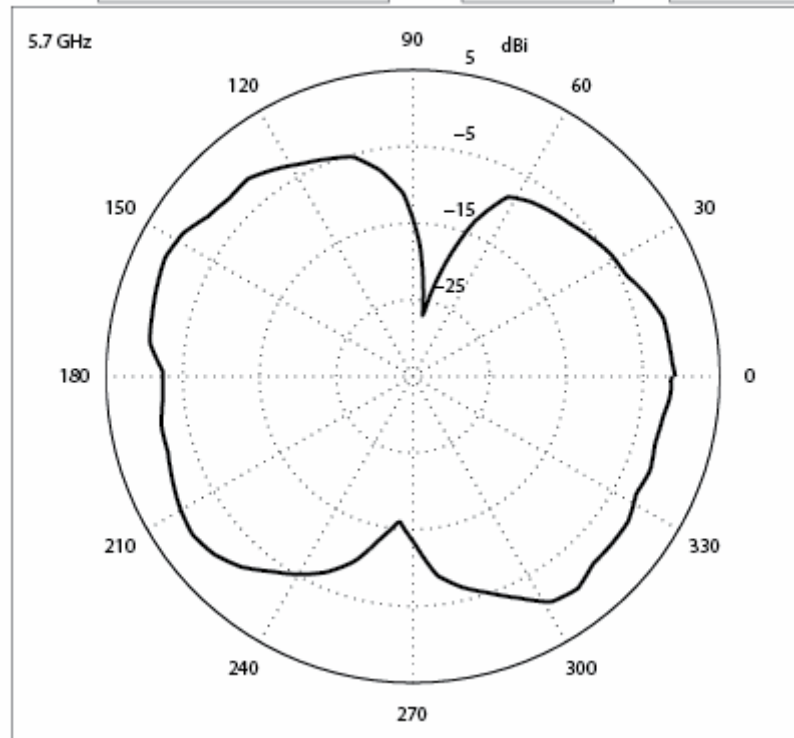

5.1.9 ML-2452-HPAG4A6-01 Outdoor Dipole Omni N-Male

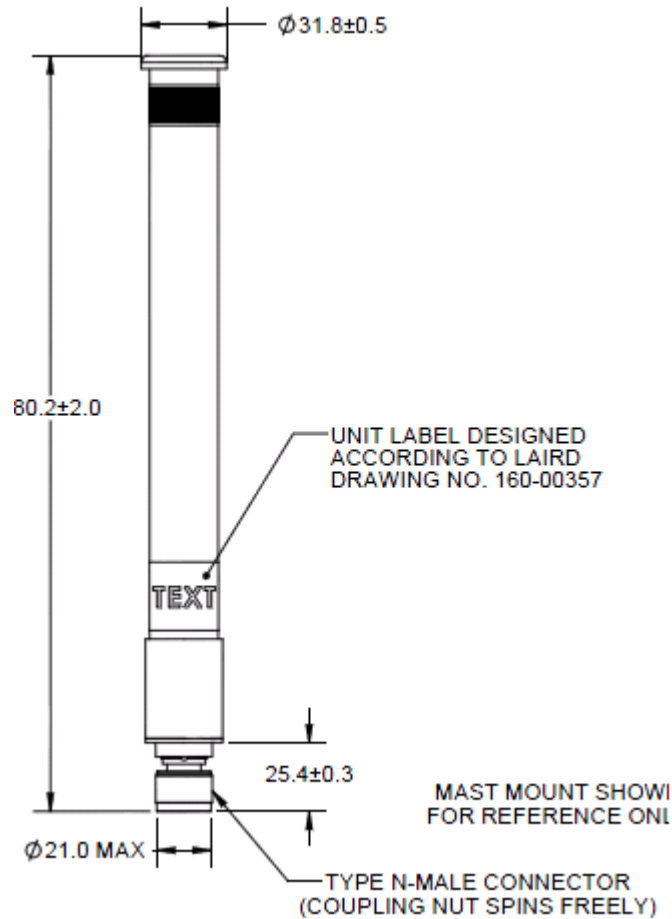

Type	Dual-band Dipole Omni
Frequency	2400-2500/4900-5900 MHz
Gain (dBi)	4.0 / 7.3
Polarization	Linear, Vertical
Azimuth	3 dB Beamwidth: 360 degrees (2.4 GHz) 3 dB Beamwidth: 360 degrees (5 GHz)
Elevation	3 dB Beamwidth: 50 degrees (2.4 GHz) 3 dB Beamwidth: 18 degrees (5 GHz)
Cable Length (in.)	N/A
Cable Type	N/A
Connector Type	N-type Male
Antenna Plenum Rated	No
Cable Plenum Rated	N/A
Outdoor Rated	Yes
Weight	0.35 lbs

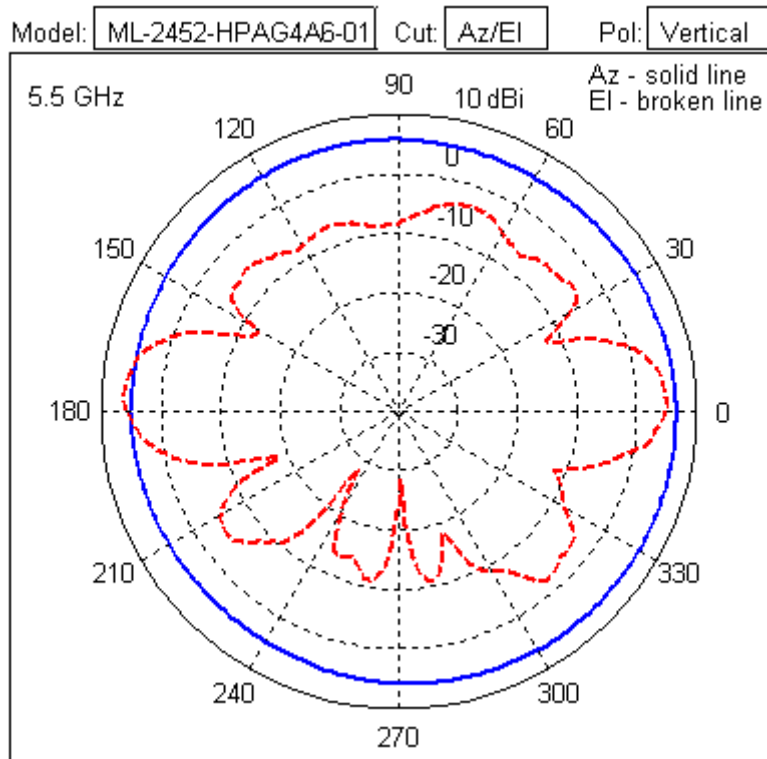
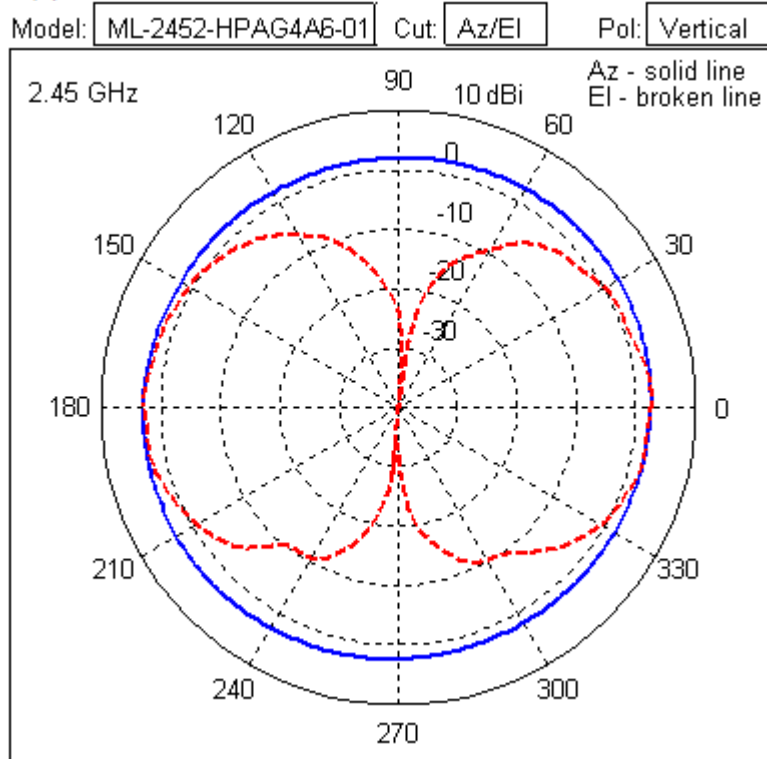

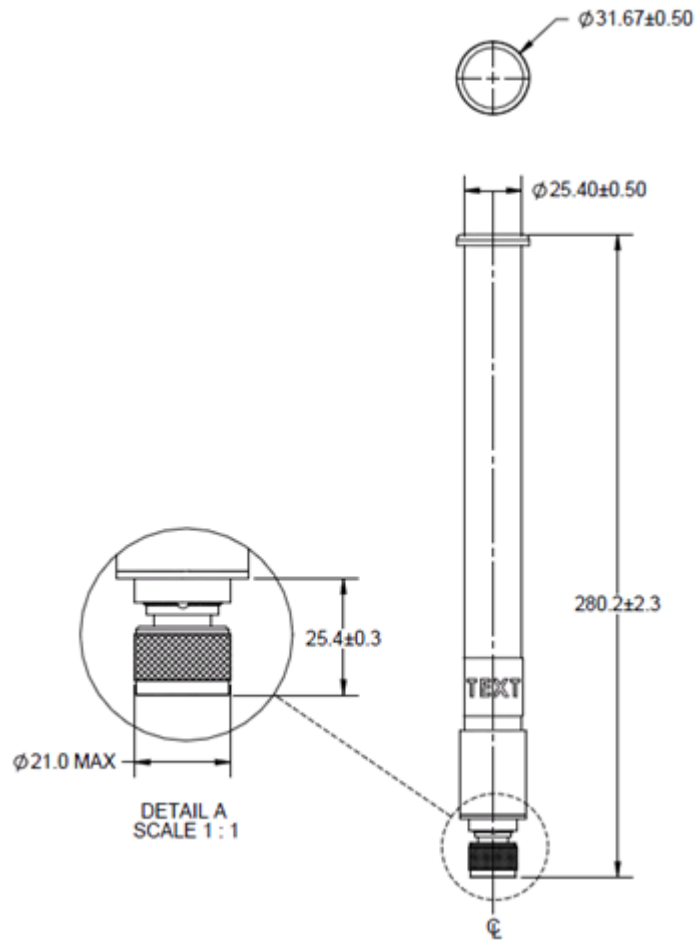
5.1.10 ML-2452-HPAG5A8-01 Outdoor Dipole Omni N-Male

<i>Type</i>	Dual-band Dipole Omni
<i>Frequency</i>	2400-2500/4900-5900 MHz
<i>Gain (dBi)</i>	7.5/ 8.0
<i>Polarization</i>	Linear, Vertical
<i>Azimuth</i>	3 dB Beamwidth: 360 degrees (2.4 GHz) 3 dB Beamwidth: 360 degrees (5 GHz)
<i>Elevation</i>	3 dB Beamwidth: 28 degrees (2.4 GHz) 3 dB Beamwidth: 15 degrees (5 GHz)
<i>Cable Length (in.)</i>	N/A
<i>Cable Type</i>	N/A
<i>Connector Type</i>	N-type Male
<i>Antenna Plenum Rated</i>	No
<i>Cable Plenum Rated</i>	N/A
<i>Outdoor Rated</i>	Yes
<i>Weight</i>	0.33 lbs

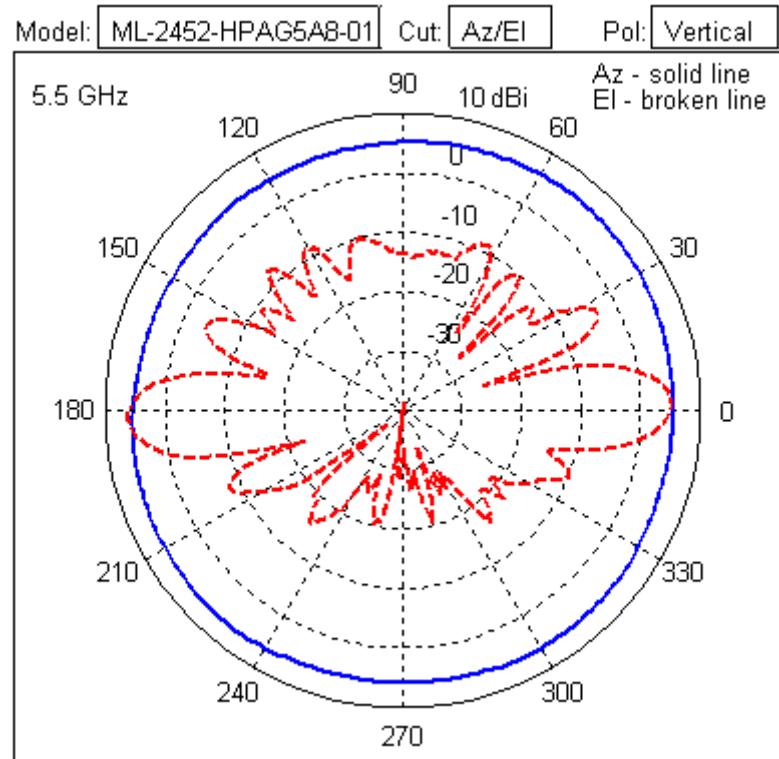
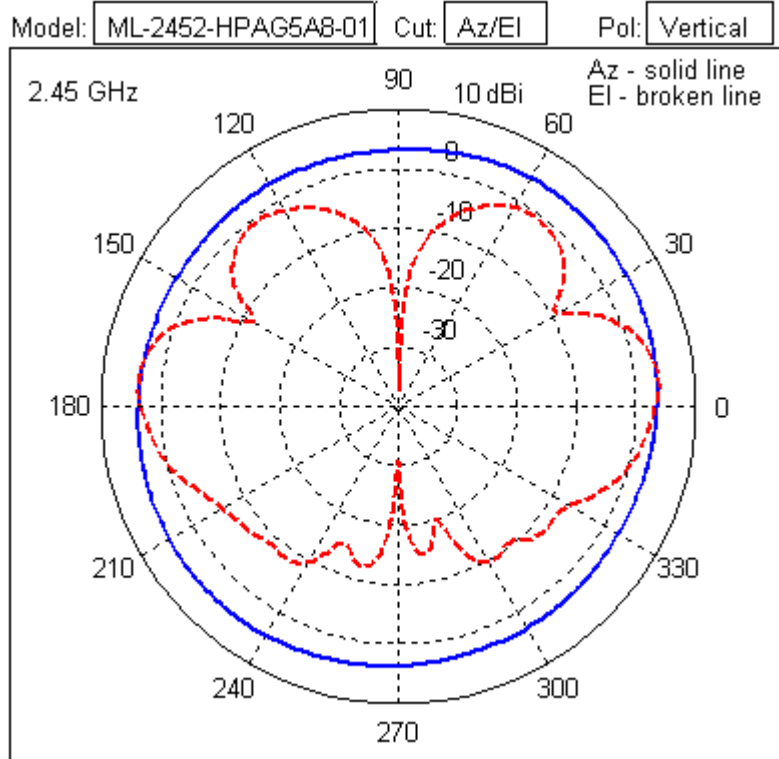

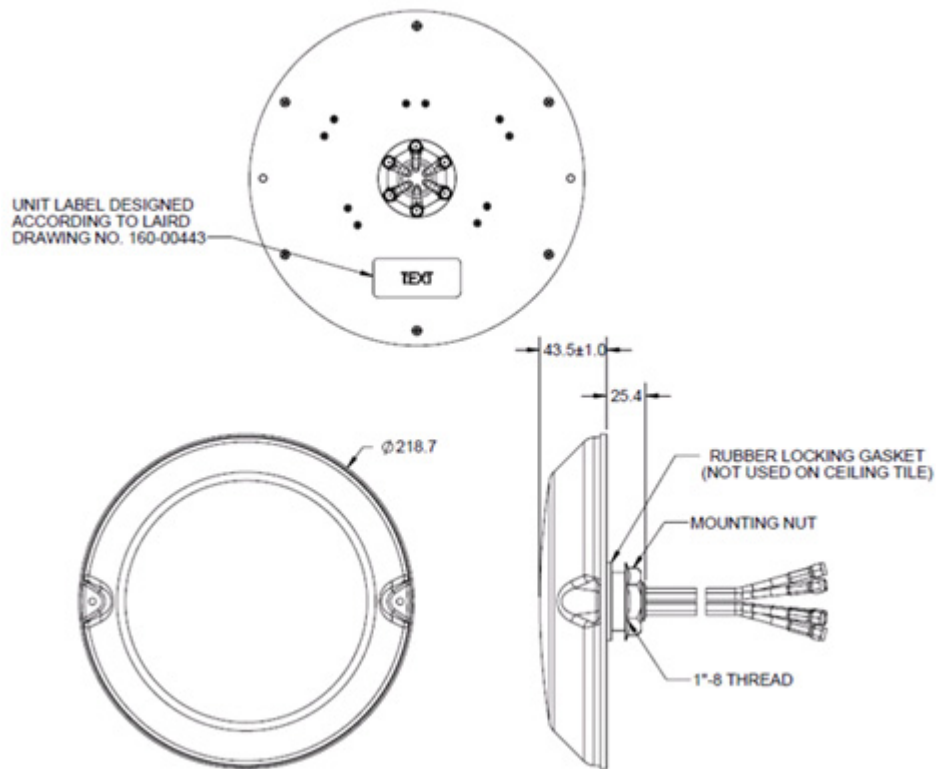
5.1.11 ML-2452-PTA6X6-036 Indoor dual-band MIMO Omni Array, RP-SMA Male

<i>Type</i>	Dual-band MIMO omni patch array, three 2.4G elements, three 5 G elements
<i>Frequency</i>	2400-2500/4900-5900 MHz
<i>Gain (dBi)</i>	3.0 / 5.0
<i>Polarization</i>	Linear, Vertical
<i>Azimuth</i>	3 dB Beamwidth: 360 degrees (2.4 GHz) 3 dB Beamwidth: 360 degrees (5 GHz)
<i>Elevation</i>	3 dB Beamwidth: 75 degrees (2.4 GHz) 3 dB Beamwidth: 42 degrees (5 GHz)
<i>Cable Length</i>	91.4 cm
<i>Cable Type</i>	RG-58
<i>Connector Type</i>	RP-SMA Male x 6
<i>Antenna Plenum Rated</i>	No
<i>Cable Plenum Rated</i>	N/A
<i>Outdoor Rated</i>	No
<i>Weight</i>	1.5 lbs

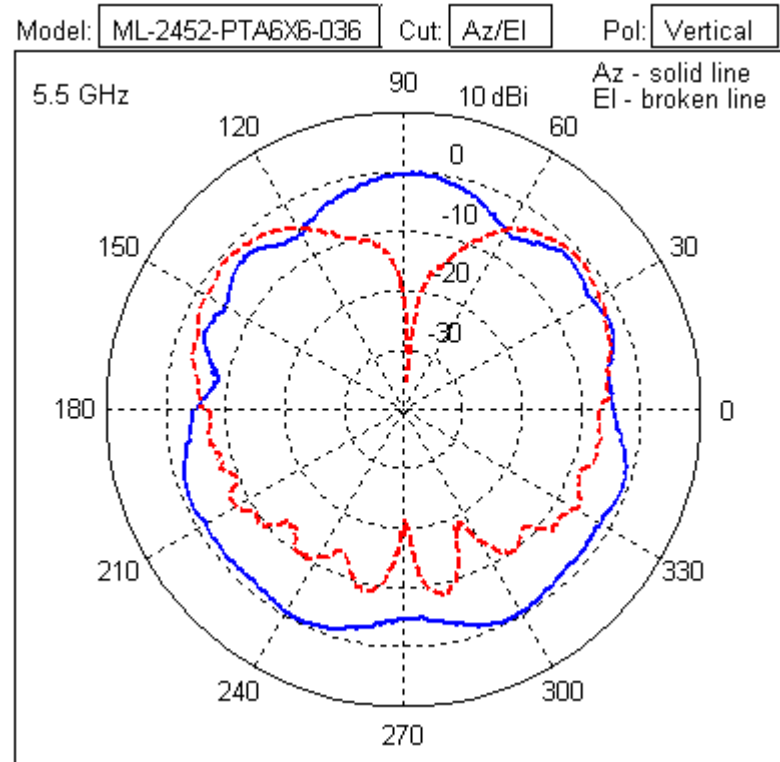
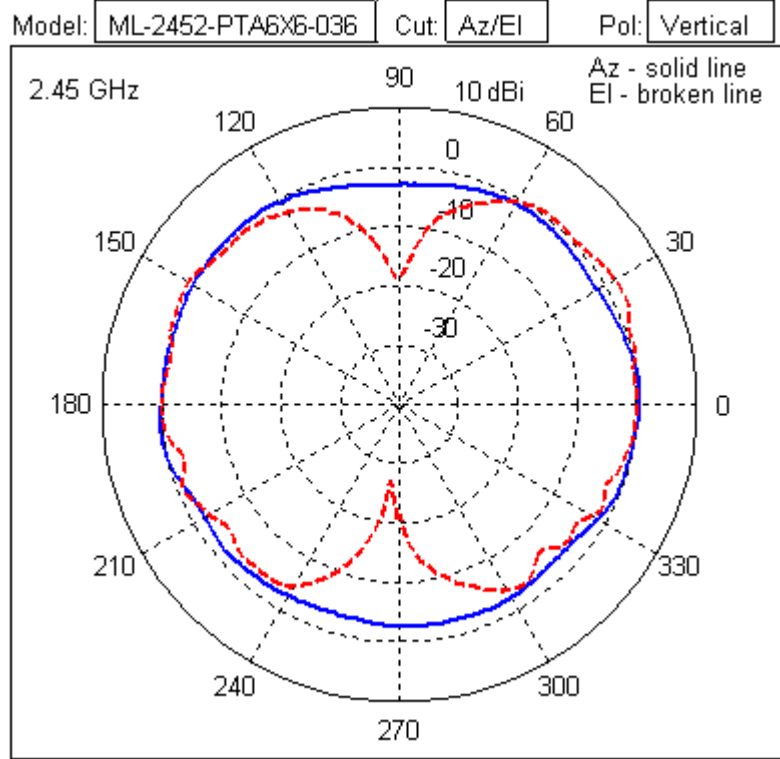

5.1.12 ML-2452-HPA6X6-036 802.11ABG 6-Port Omni Dipole Array, Type N Male x6

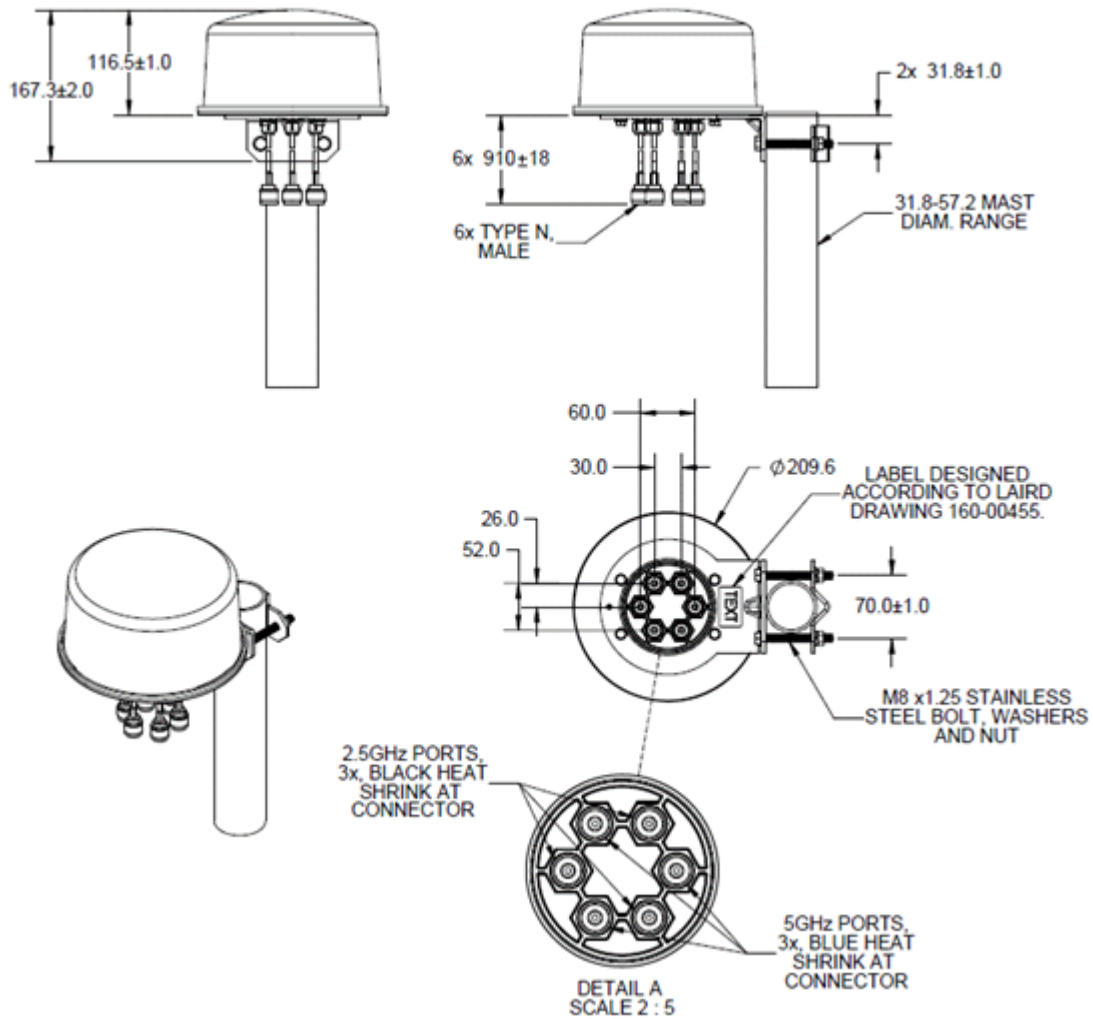

Type	11ABGN, 6P SB Omni , 4/6 dBi, LP, CBL 48, N-M
Frequency	2400-2500/4900-5900 MHz
Gain (dBi)	4.0 /6.0
Polarization	Linear, Vertical
Azimuth	3 dB Beamwidth: 360 degrees (2.4 GHz) 3 dB Beamwidth: 360 degrees (5 GHz)
Elevation	3 dB Beamwidth: 45 degrees (2.4 GHz) 3 dB Beamwidth: 32 degrees (5 GHz)
Cable Length	91.0 cm
Cable Type	RG-58
Connector Type	Type N Male x 6

<i>Antenna Plenum Rated</i>	N/A
<i>Cable Plenum Rated</i>	Yes
<i>Outdoor Rated</i>	Yes
<i>Weight</i>	2.5 lbs

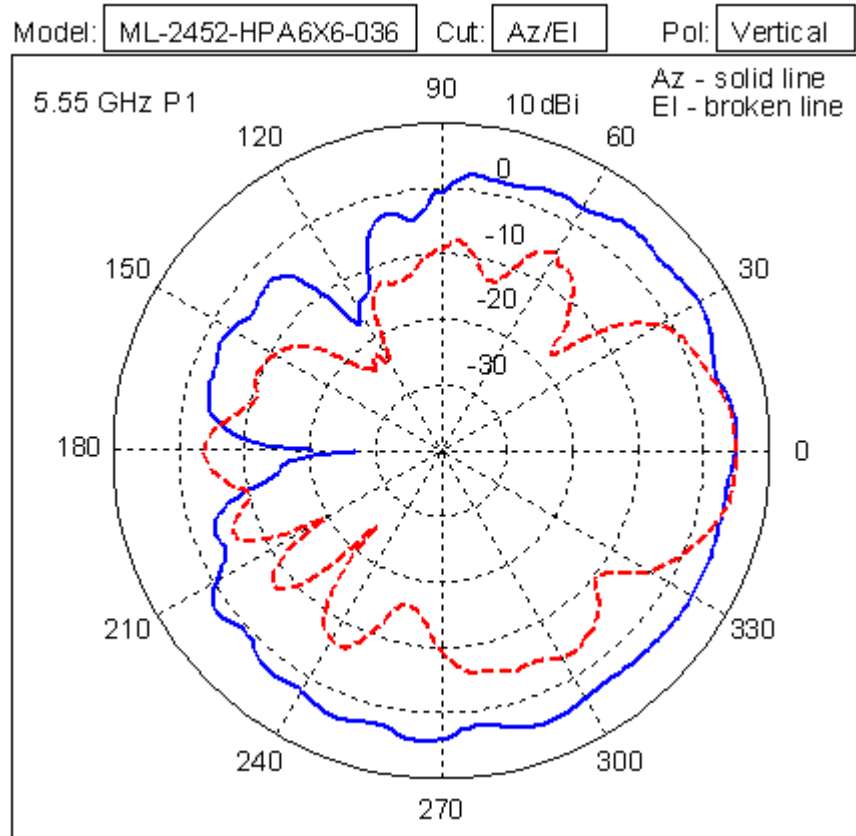
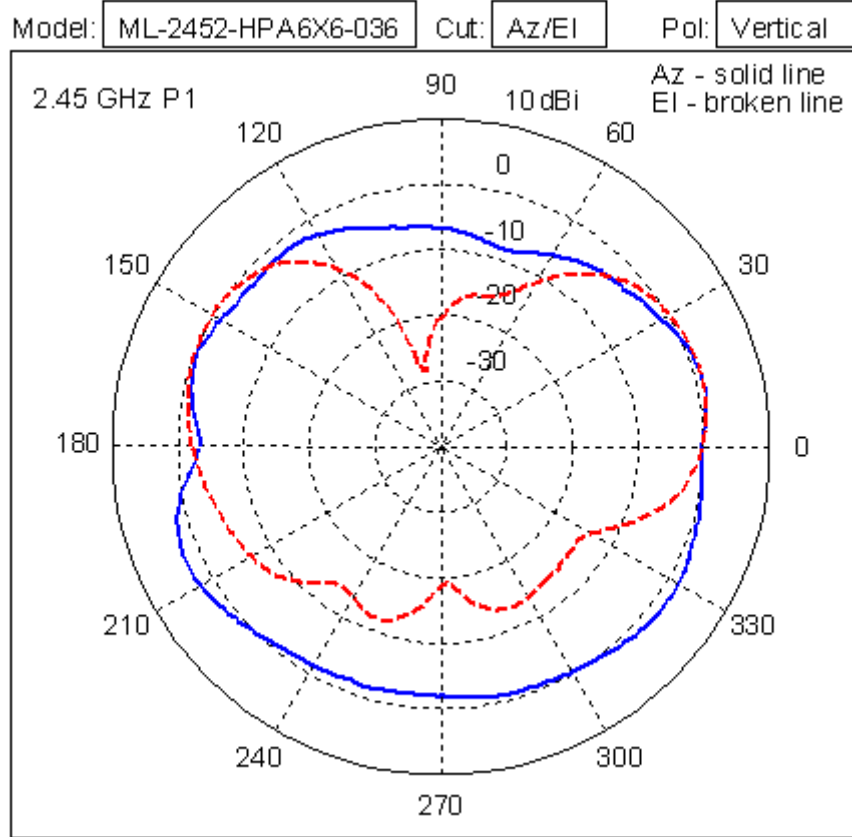

Model: Cut: Pol:

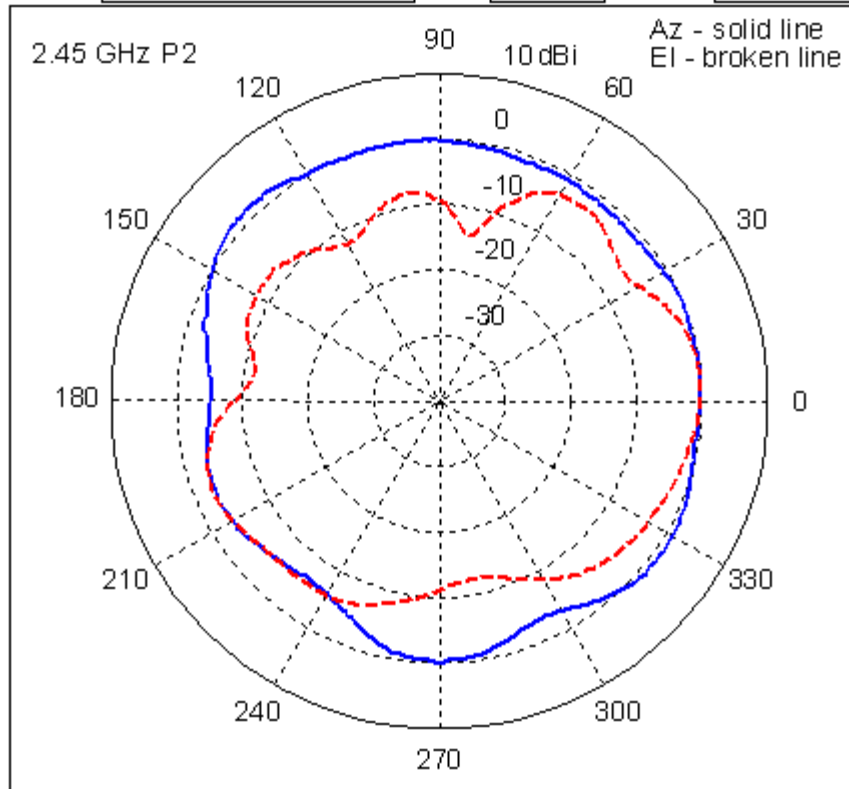

Model: Cut: Pol:

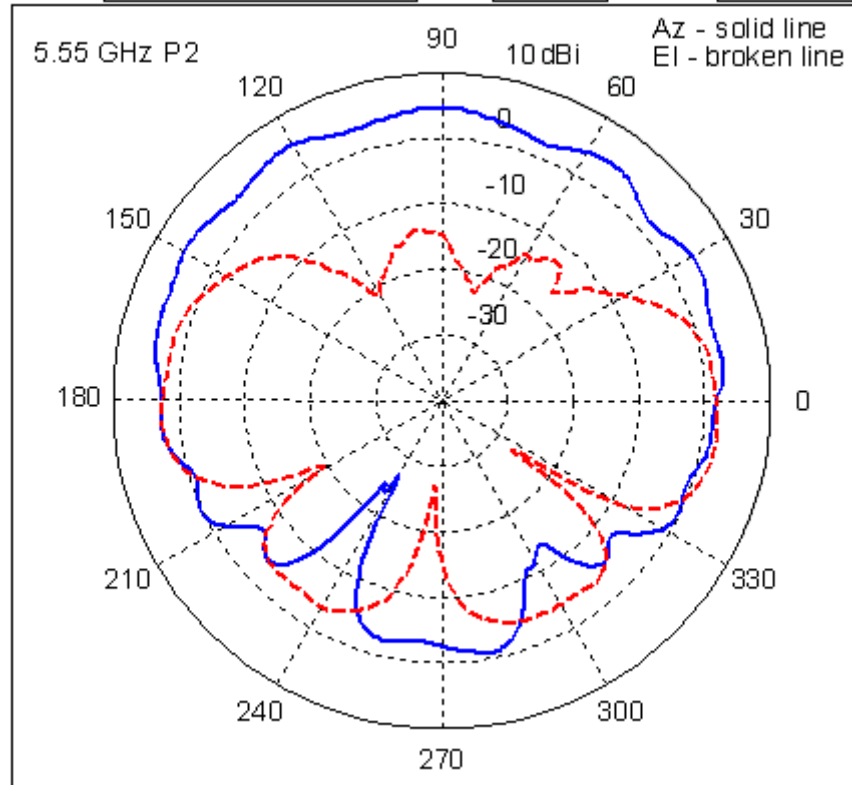

Model: Cut: Pol:

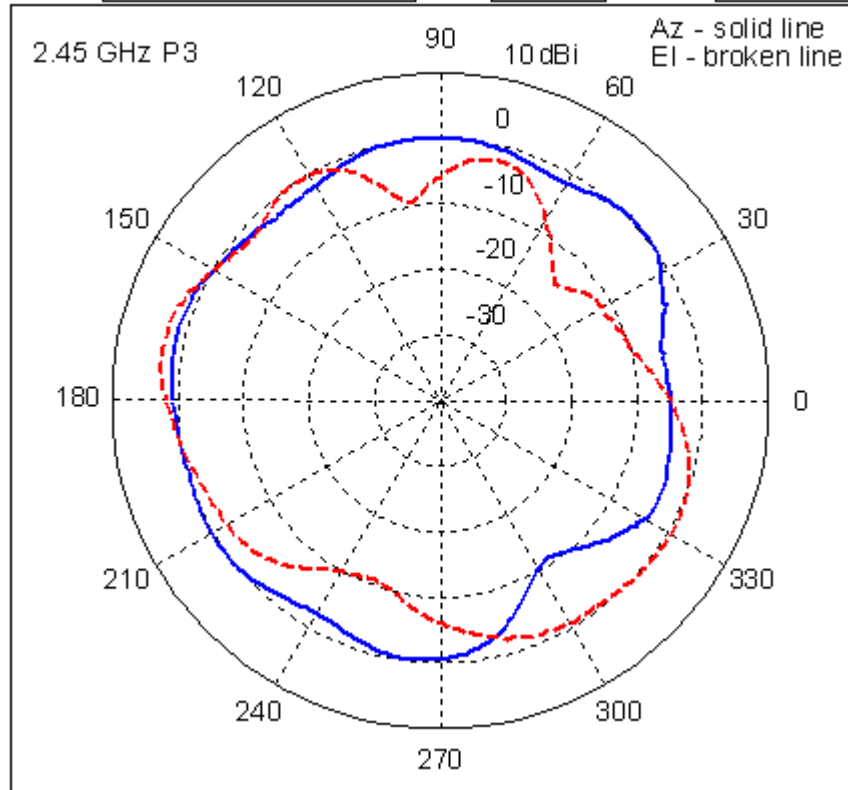

Model: Cut: Pol:

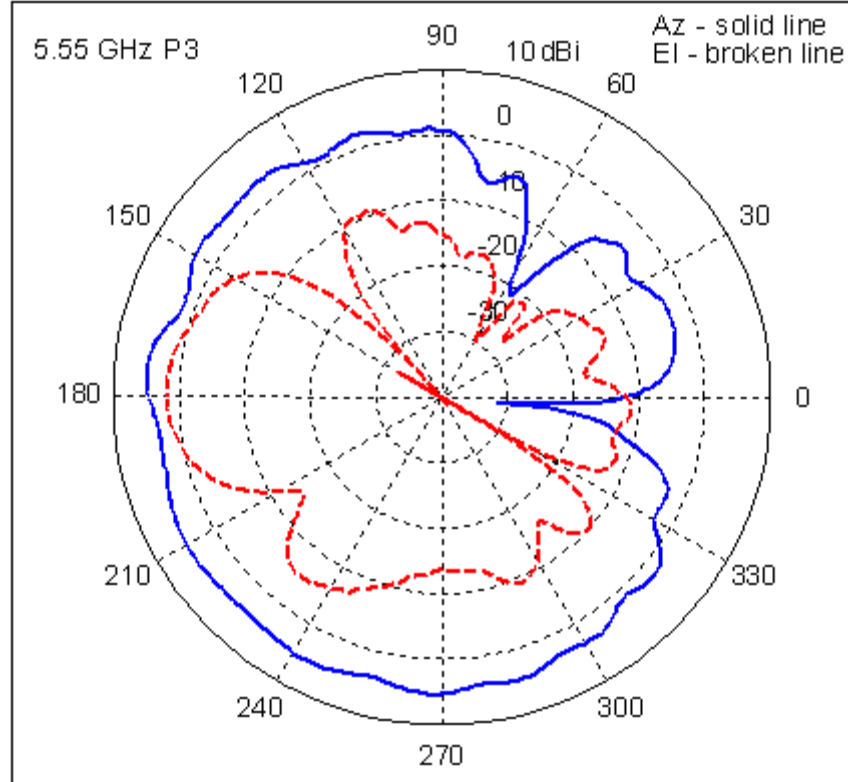

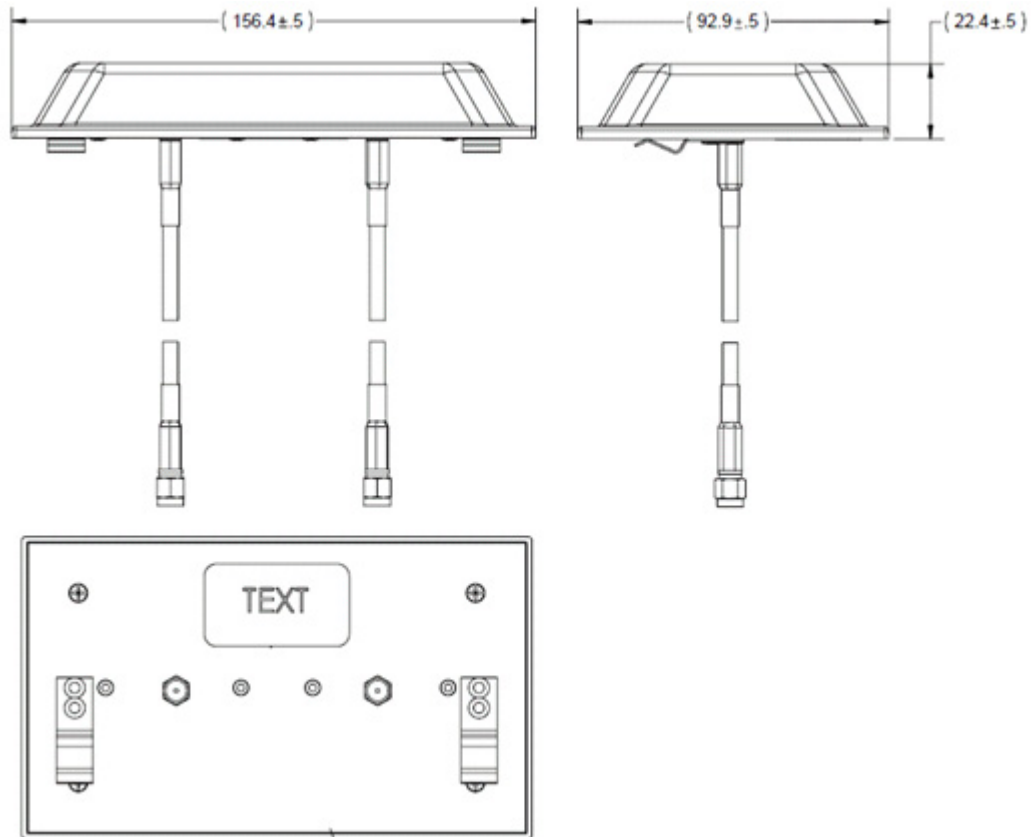
5.1.13 ML-2452-PTA2M2-036 802.11ABG 2-Port Patch Array, RP-SMA Male

<i>Type</i>	11ABGN, Two-port, dual-band omni patch array
<i>Frequency</i>	2400-2500/4900-5990 MHz
<i>Gain (dBi)</i>	4.0 /5.0
<i>Polarization</i>	Linear, Vertical
<i>Azimuth</i>	3 dB Beamwidth: 360 degrees (2.4 GHz) 3 dB Beamwidth: 360 degrees (5 GHz)
<i>Elevation</i>	3 dB Beamwidth: 60 degrees (2.4 GHz) 3 dB Beamwidth: 60 degrees (5 GHz)
<i>Cable Length</i>	91.4 cm
<i>Cable Type</i>	RG-58
<i>Connector Type</i>	RP-SMA Male
<i>Antenna Plenum Rated</i>	Yes
<i>Cable Plenum Rated</i>	N/A
<i>Outdoor Rated</i>	No
<i>Weight</i>	0.5 lbs

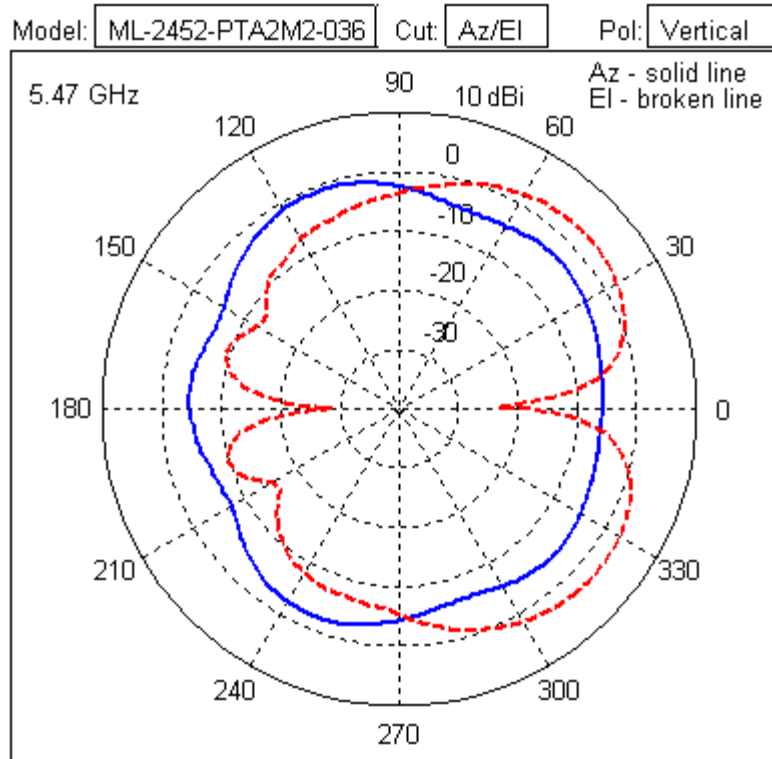
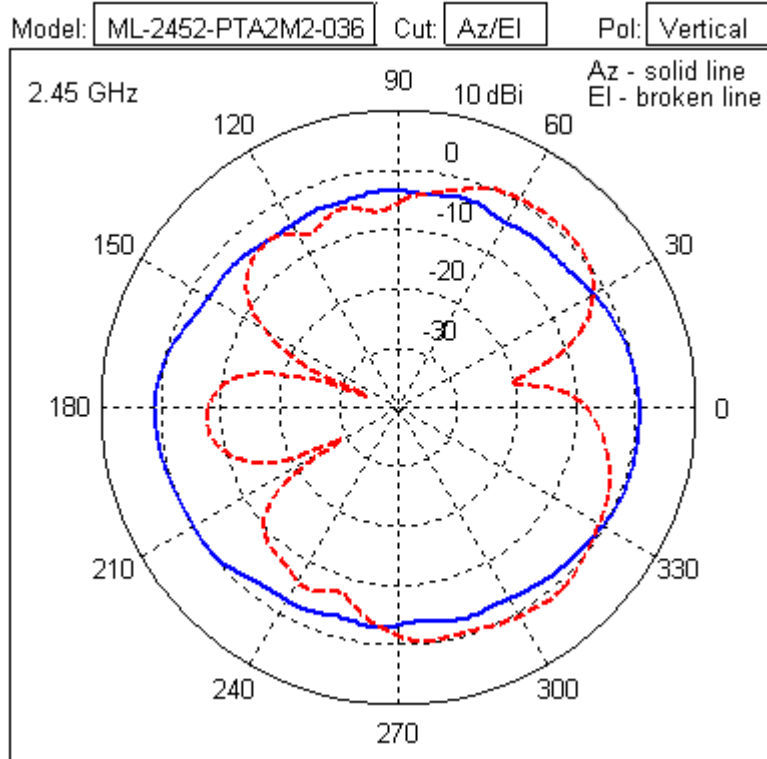

5.1.14 ML-2452-PTA6M6-036 Six-Port Omnidirectional Panel, RP-SMA Male

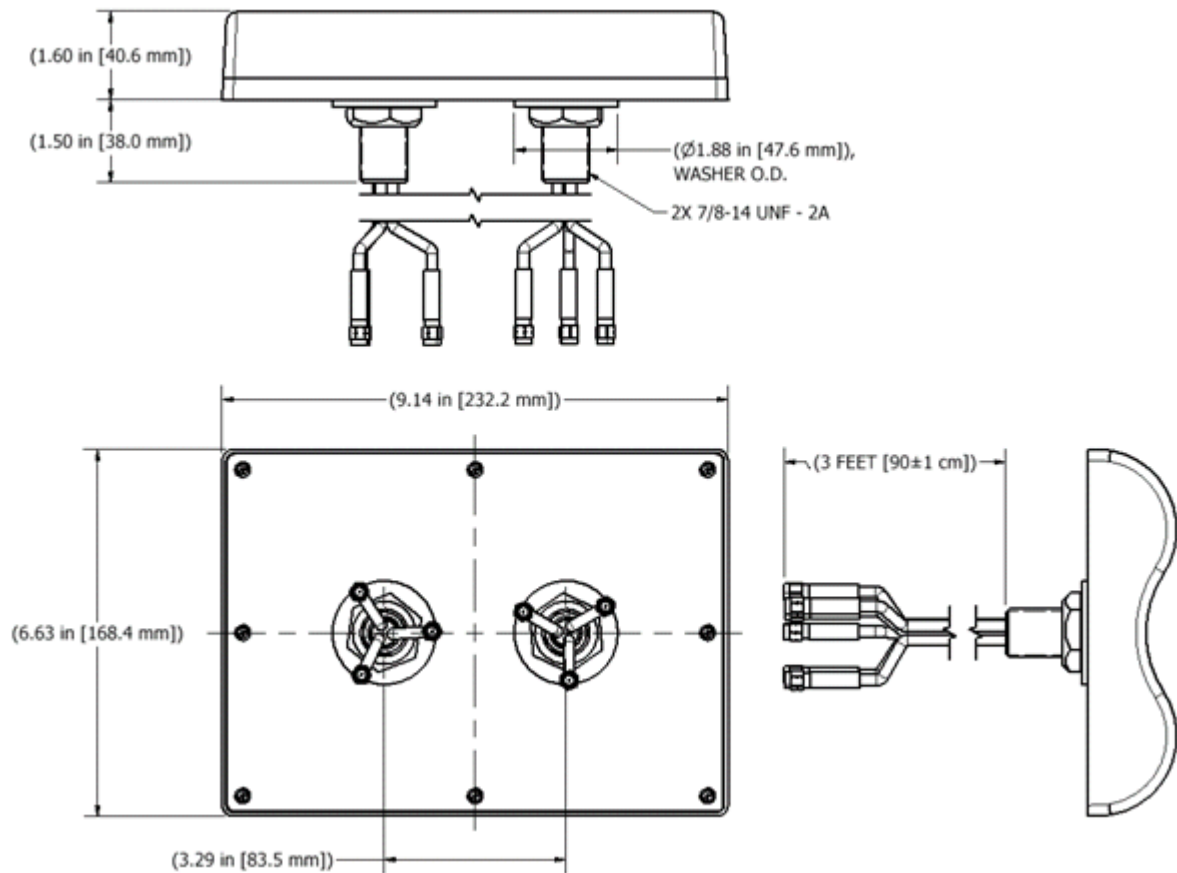

Type	6-Port Omnidirectional Panel
Frequency	2400-2500/4900-5900 MHz
Gain (dBi)	4.0 /5.0
Polarization	Linear, Vertical
Azimuth	3 dB Beamwidth: 360 degrees (2.4 GHz) 3 dB Beamwidth: 360 degrees (5 GHz)
Elevation	3 dB Beamwidth: 55 degrees (2.4 GHz) 3 dB Beamwidth: 45 degrees (5 GHz)
Cable Length	90 cm
Cable Type	RG-58
Connector Type	RP-SMA Male
Antenna Plenum Rated	N/A
Cable Plenum Rated	Yes
Outdoor Rated	No
Weight	1.5 lbs

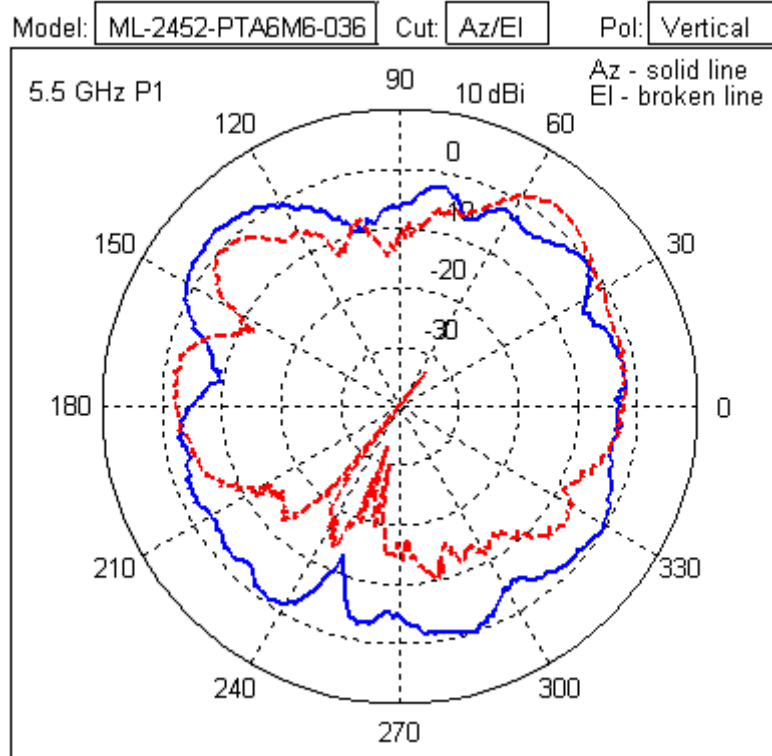
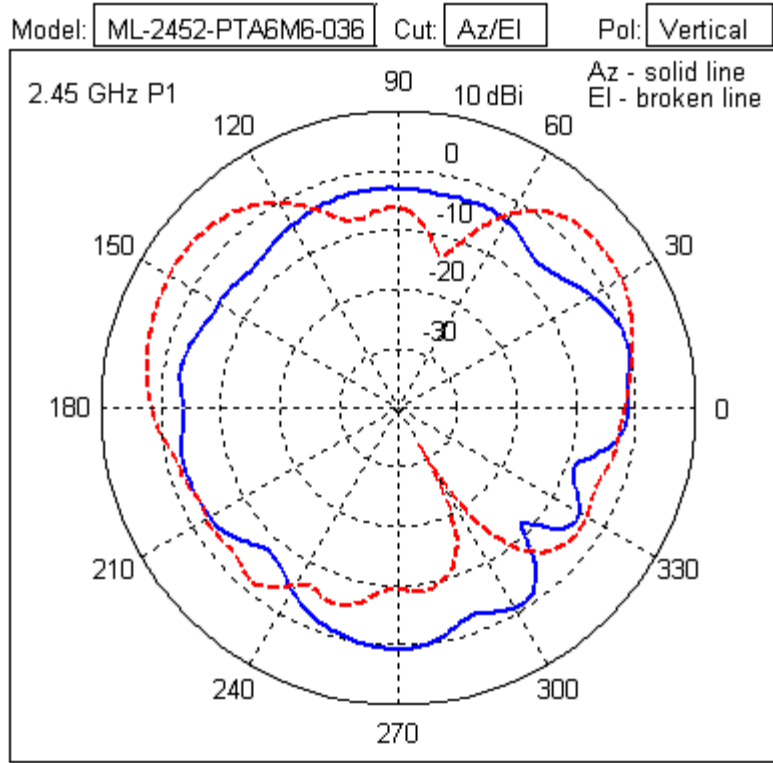

Model: Cut: Pol:

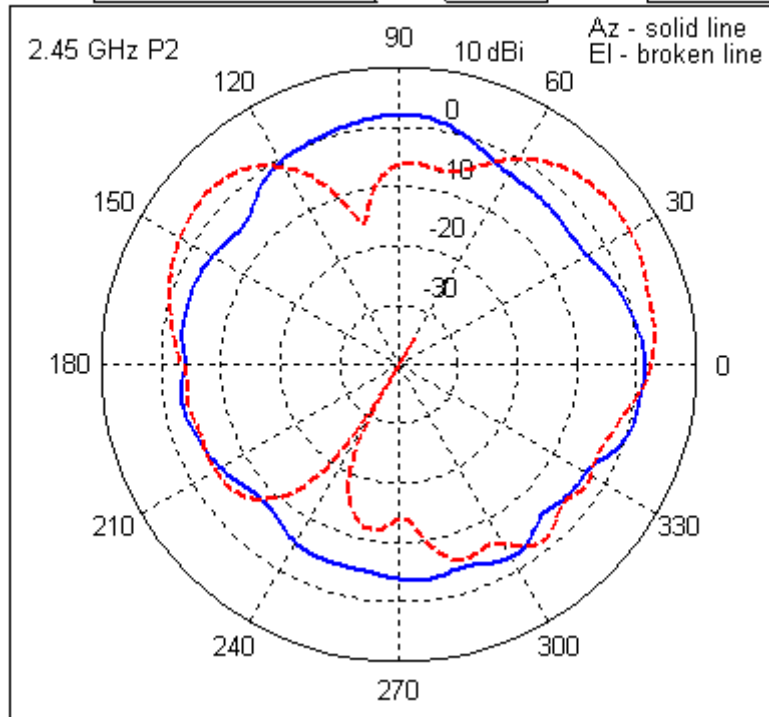

Model: Cut: Pol:

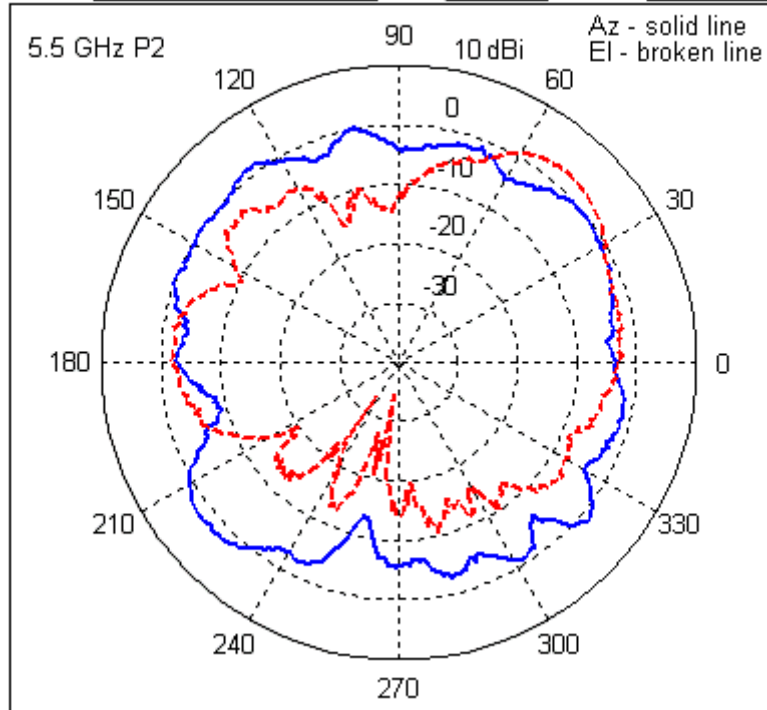

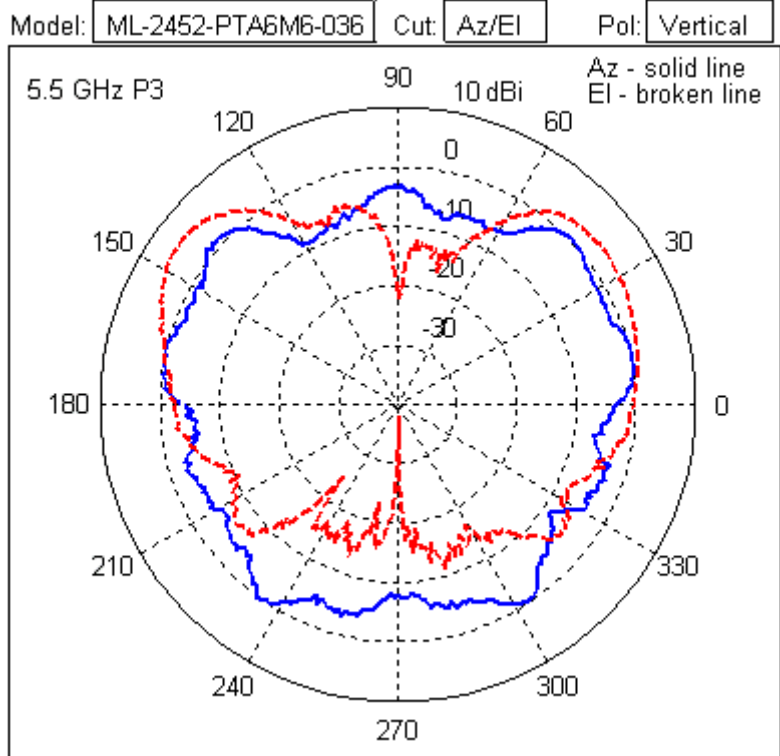
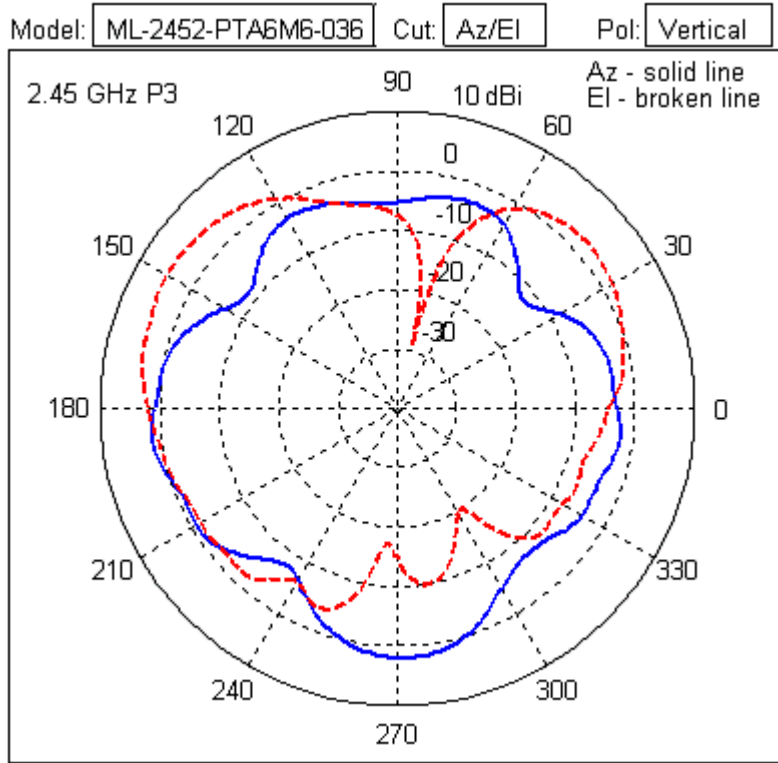

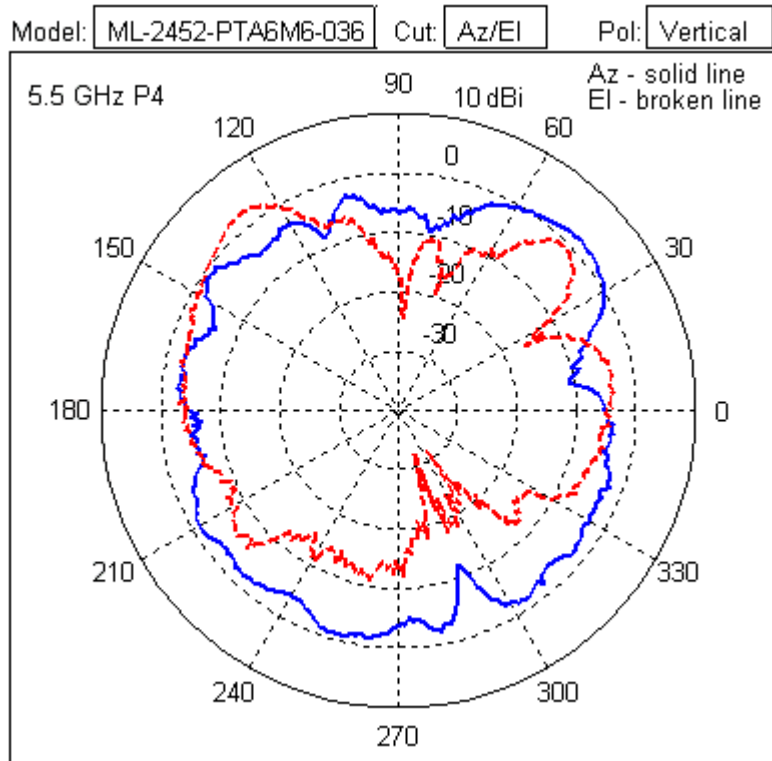
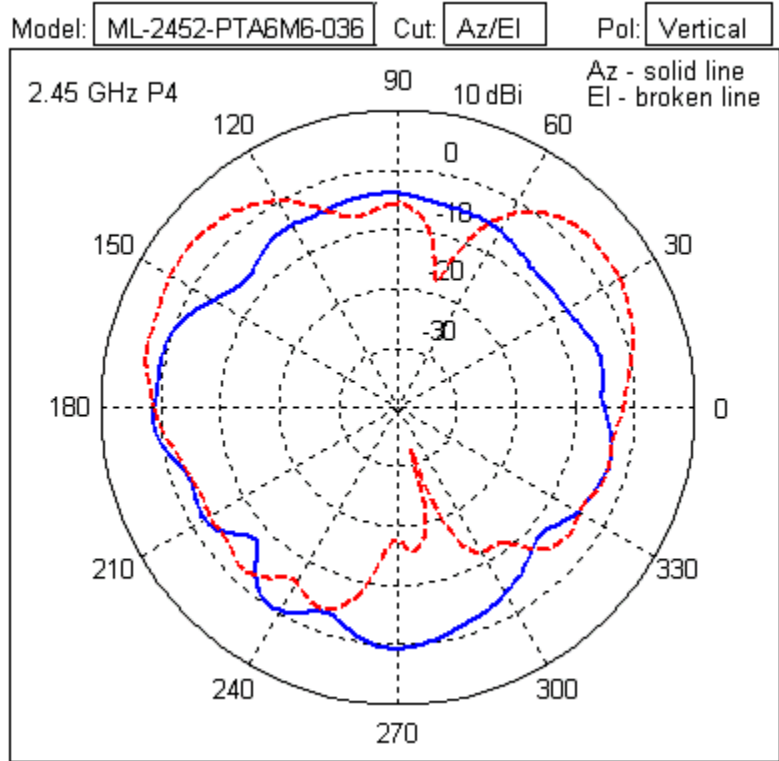

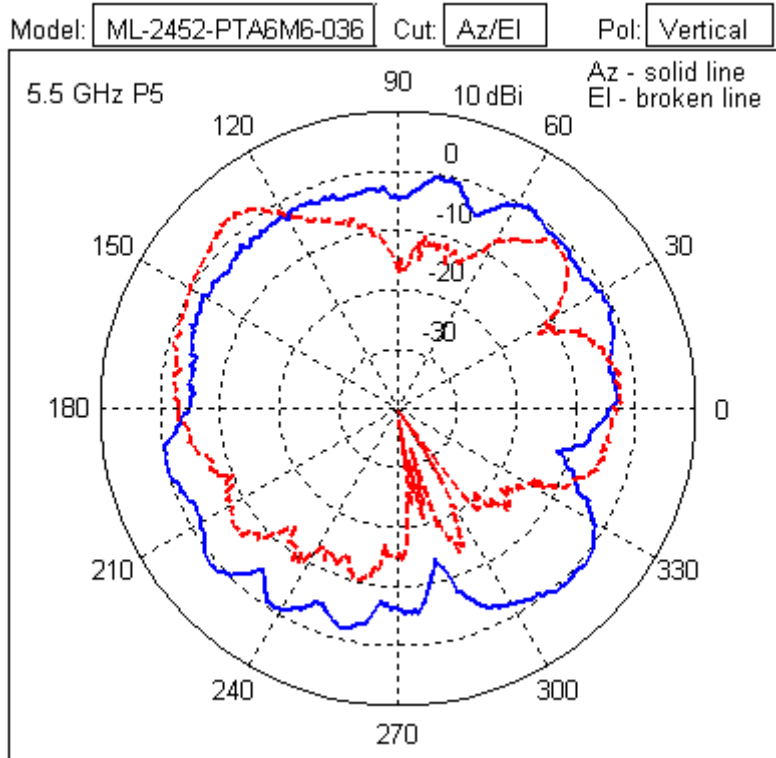
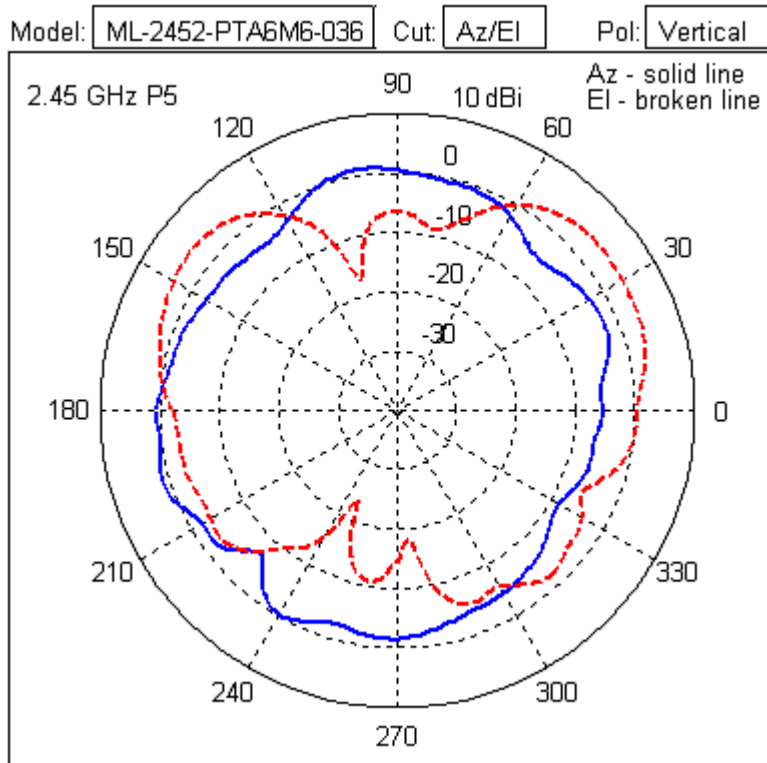

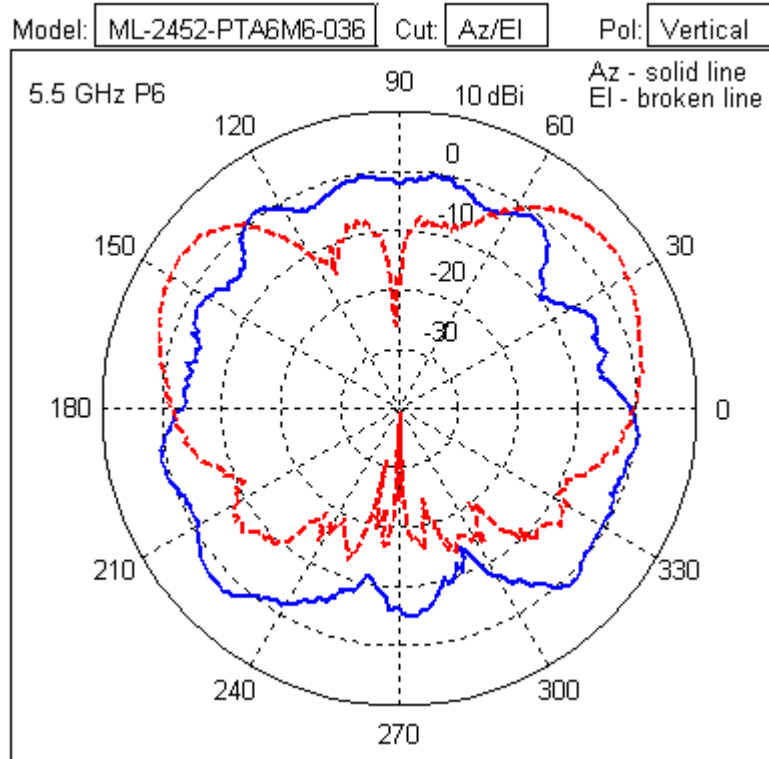
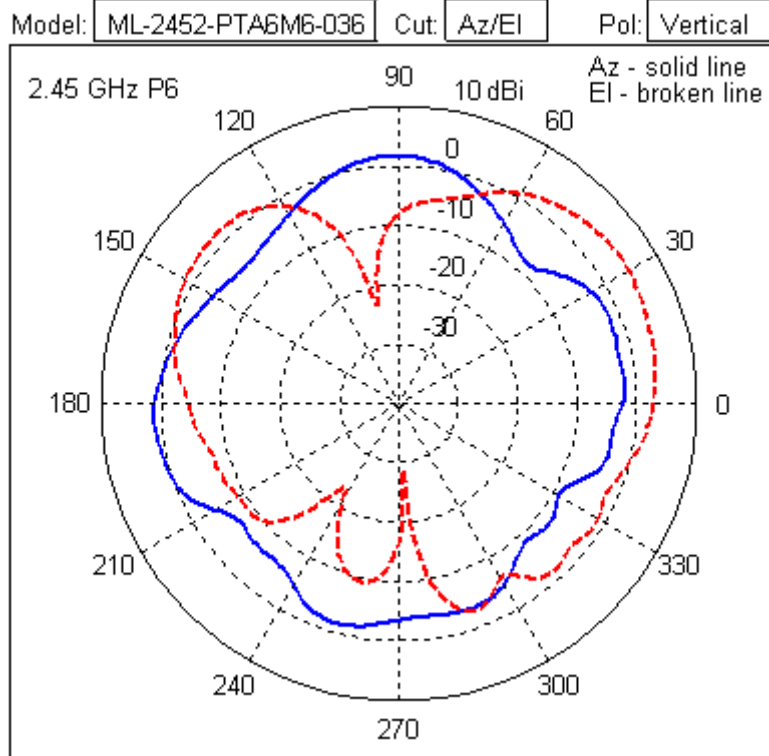

6

Antenna Cables

6.1 Supported Antenna Cables

Motorola Solutions supports numerous cables to suit your unique access point or access port deployment. Check the Motorola Solutions Web site periodically, as new cables will be added to this document as they are released. For more information, go to <http://supportcentral.motorola.com/support/product/manuals.do>.

For detailed information on supported cables, refer to:

- *ML-1499-10JK-01R 10 ft. Low-Loss Coaxial Cable Jumper: N Male to N Male*
- *ML-1499-25JK-01R 25 ft. Low-Loss Coaxial Cable Jumper: N Male to N Male with 2 Connector Seal Kits*
- *ML-1499-50JK-01R 50 ft. Low-Loss Coaxial Cable Jumper: N Male to N Male with 2 Connector Seal Kits*

6.1.1 ML-1499-10JK-01R 10 ft. Low-Loss Coaxial Cable Jumper: N Male to N Male

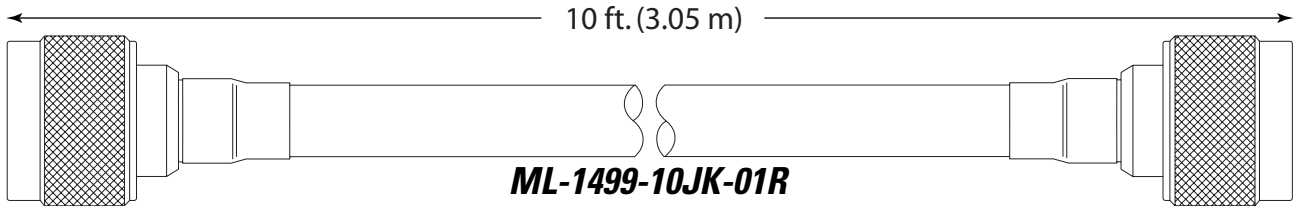

Type	Ultralink TL 93605
RF Connectors	N (m) to N (m)
Cable Attenuation (dB)	2.0 @ 2.4 GHz; 2.9 @ 5.8 GHz
Frequency	2 - 6 GHz

6.1.2 ML-1499-25JK-01R 25 ft. Low-Loss Coaxial Cable Jumper: N Male to N Male with 2 Connector Seal Kits

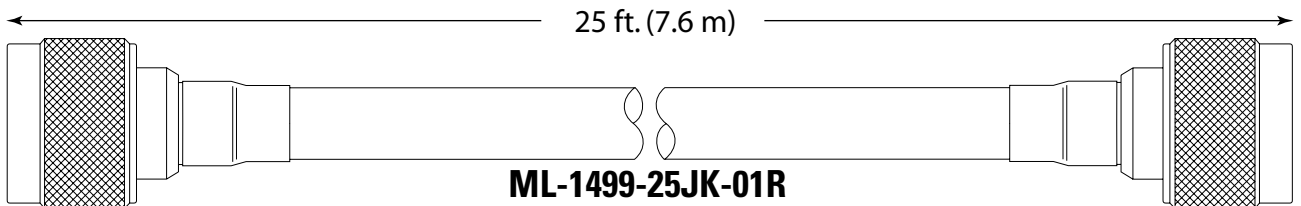

Type	Ultralink TL 93605
RF Connectors	N (m) to N (m)
Cable Attenuation (dB)	2.5 @ 2.4 GHz; 4.0 @ 5.8 GHz
Frequency	2 - 6 GHz

6.1.3 ML-1499-50JK-01R 50 ft. Low-Loss Coaxial Cable Jumper: N Male to N Male with 2 Connector Seal Kits

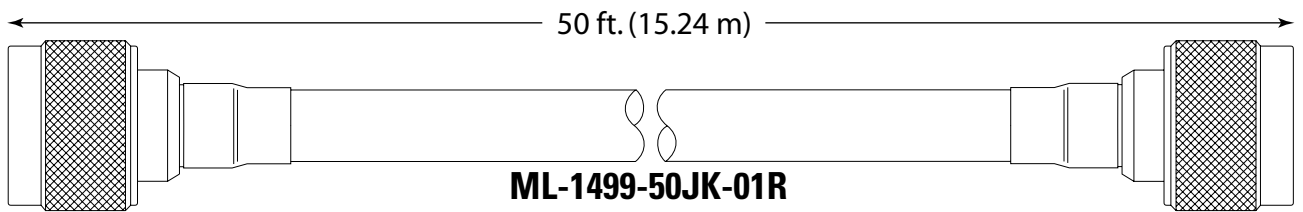

<i>Type</i>	Ultralink TL 93605
<i>RF Connectors</i>	N (m) to N (m)
<i>Cable Attenuation (dB)</i>	4.5 @ 2.4 GHz; 7.0 @ 5.8 GHz
<i>Frequency</i>	2 - 6 GHz

Supported Antenna Adapters

7.1 Supported Adapters

Motorola Solutions supports many adapters to suit your unique access point or access port deployment. Check the Motorola Solutions Web site periodically, as new adapters will be added to this document as they are released. For more information, go to <http://supportcentral.motorola.com/support/product/manuals.do>.

For detailed information on supported antenna adapters, refer to:

- *25-85391-01R 3.5 in. Jumper Cable, RP-SMA (Male) to Type N (Male) Adaptor*
- *25-85392-01R 3.5 in. Jumper Cable, RP-SMA (Male) to Type N (Female) Adaptor*
- *25-72178-01 Jumper, RP-SMA(M) to RP-BNC(F)*
- *25-90262-01R RP-SMA (Female) to Type N (Female) Adapter*
- *25-90263-01R Type N (Male) to RP-SMA (Female) Bulkhead Adapter*
- *25-97261-01R Connector for ML-2499-BYGA2-01R and AP300*
- *25-99175-01R Type N, Female to Female Adaptor*

7.1.1 25-85391-01R 3.5 in. Jumper Cable, RP-SMA (Male) to Type N (Male) Adaptor

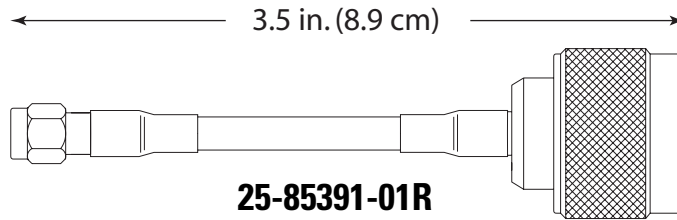

Type	Clear Jacket, RG-316
Connector 1	RP-SMA, Male
Connector 2	Type N, Male
Insertion Loss	2.4 GHz: 0.2 dB MIN
Insertion Loss	5.2 GHz: 0.3 dB MIN

7.1.2 25-85392-01R 3.5 in. Jumper Cable, RP-SMA (Male) to Type N (Female) Adaptor

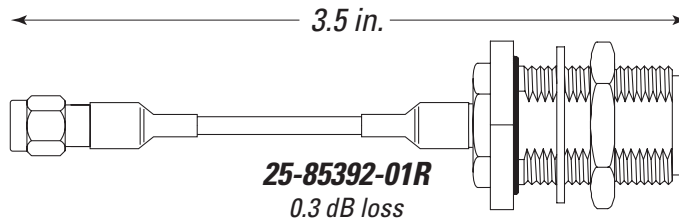

Type	Clear Jacket, RG-316
Connector 1	RP-SMA, Male
Connector 2	Type N, Female, Bulkhead
Insertion Loss	2.4 GHz: 0.2 dB MIN
Insertion Loss	5.2 GHz: 0.3 dB MIN

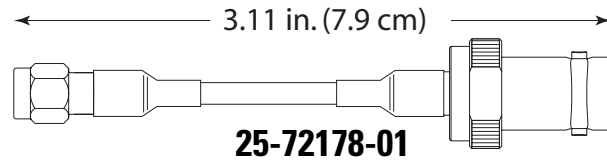
7.1.3 25-72178-01 Jumper, RP-SMA(M) to RP-BNC(F)

Type	RG-316
Connector 1	RP-SMA, Male
Connector 2	RP-BNC, Female
Insertion Loss	2.4 GHz: .2 dB
Insertion Loss	5.2 GHz: .3 dB

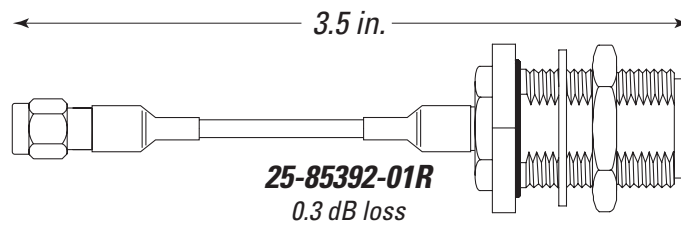
7.1.4 25-90262-01R RP-SMA (Female) to Type N (Female) Adapter

Type	RG-316
Connector 1	RP-SMA, Female, Bulkhead
Connector 2	Type N, Female, Bulkhead
Insertion Loss	2.4 GHz: .2 dB
Insertion Loss	5.2 GHz: .3 dB

7.1.5 25-90263-01R Type N (Male) to RP-SMA (Female) Bulkhead Adapter

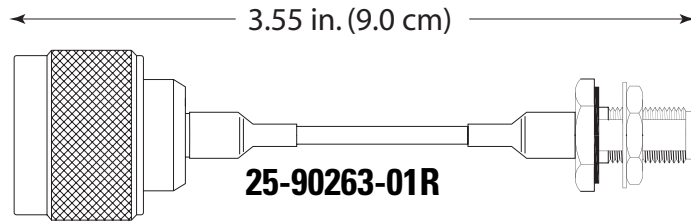

<i>Type</i>	RG-316
<i>Connector 1</i>	Type N, Male
<i>Connector 2</i>	RP-SMA, Female, Bulkhead
<i>Insertion Loss</i>	2.4 GHz: 0.2 dB MIN
<i>Insertion Loss</i>	5.2 GHz: 0.3 dB MIN

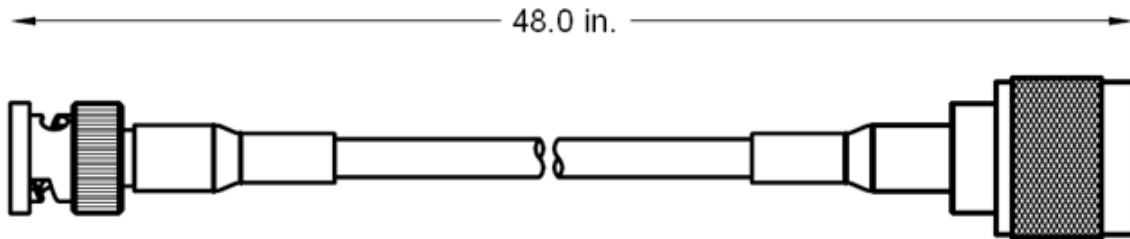
7.1.6 25-97261-01R Connector for ML-2499-BYGA2-01R and AP300

Type	RG-316
Frequency (MHz)	2400-2500
Connector 1	Type N, Male
Connector 2	RP-BNC-Male
Cable Loss (dB)	1.5
Cable Length (inches)	48
Color	Black

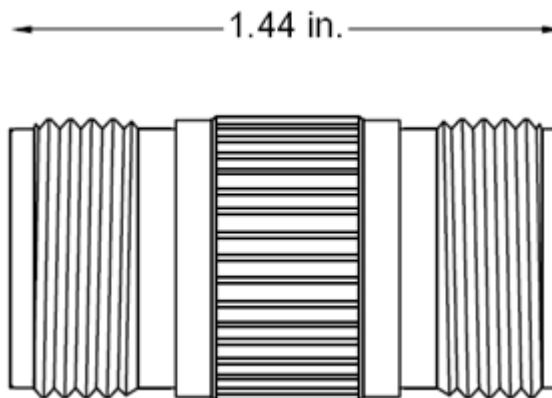
7.1.7 25-99175-01R Type N, Female to Female Adaptor

Connector 1	Type N, Female
Connector 2	Type N, Female
Cable Loss (dB)	0.3
Cable Length (inches)	1.44

Supported Lightning Arrestors

8.1 Lightning Arrestors

Motorola Solutions supports several lightning arrestors to support your unique access point or access port deployment safety requirements. Check the Motorola Solutions Web site periodically, as new lightning arrestors will be added to this document as they are released. For more information, go to <http://supportcentral.motorola.com/support/product/manuals.do>.

For detailed information on supported lightning arrestors refer to:

- *ML-1499-LAK1-01R 1 ft. N Male to RP BNC Male Lightning Arrestor with Connector Seal Kit*
- *ML-1499-LAK2-01R Lightning Arrestor Kit with N Male to N Male Barrel Adapter*
- *ML-2452-LAK1-01R Lightning Arrestor (N Female to N Female) with N Male to RP-SMA Male Adapter*



WARNING! The grounding lug on a lightning arrestor must be grounded in compliance with local electrical codes.

8.1.1 ML-1499-LAK1-01R 1 ft. N Male to RP BNC Male Lightning Arrestor with Connector Seal Kit

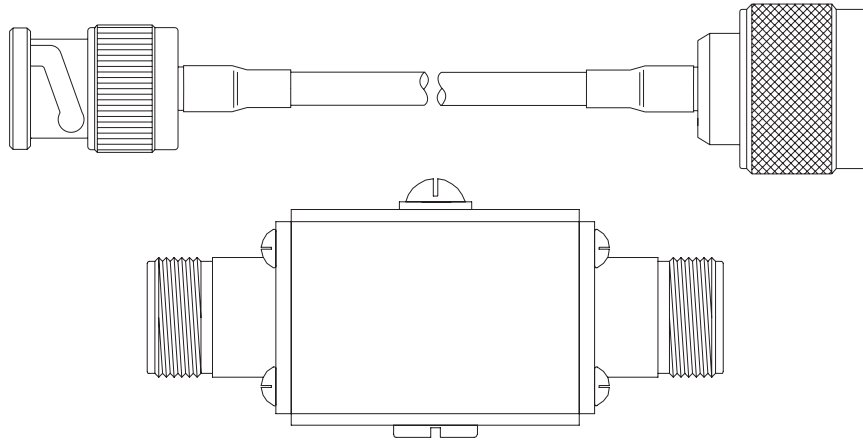

ML-1499-LAK1-01R

<i>Cable</i>	Black, Ultralink, RG-58
<i>RF Connectors</i>	N (m) to RP. BNC (m)
<i>Arrestor RF Connectors</i>	N (f) to N (f)
<i>Frequency</i>	2400-2500 MHz
<i>Insertion Loss - Lightning Arrestor</i>	0.25 dB @ 2.4 GHz
<i>Insertion Loss - Cable</i>	0.6 dB @ 2.4 GHz



NOTE: Not for use above 2500 MHz.

8.1.2 ML-1499-LAK2-01R Lightning Arrestor Kit with N Male to N Male Barrel Adapter

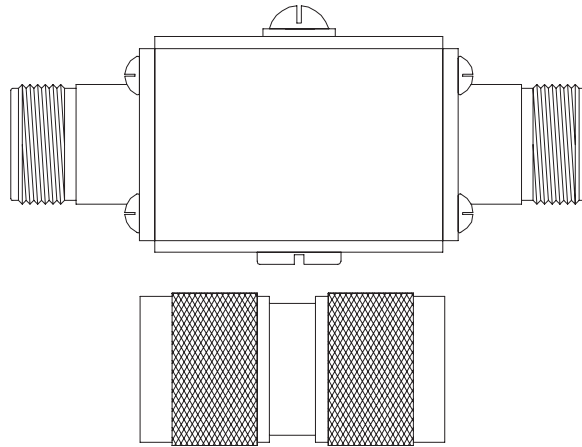

ML-1499-LAK2-01R

<i>RF Connectors</i>	N (m) to N (m)
<i>Arrestor RF Connectors</i>	N (f) to N (f)
<i>Frequency</i>	2400-2500 MHz
<i>Maximum RF Power</i>	100 W
<i>Insertion Loss - Lightning Arrestor</i>	0.25 dB @ 2.4 GHz / 14 dB @ 5.5GHz



NOTE: Not for use above 2500 MHz.

8.1.3 ML-2452-LAK1-01R Lightning Arrestor (N Female to N Female) with N Male to RP-SMA Male Adapter

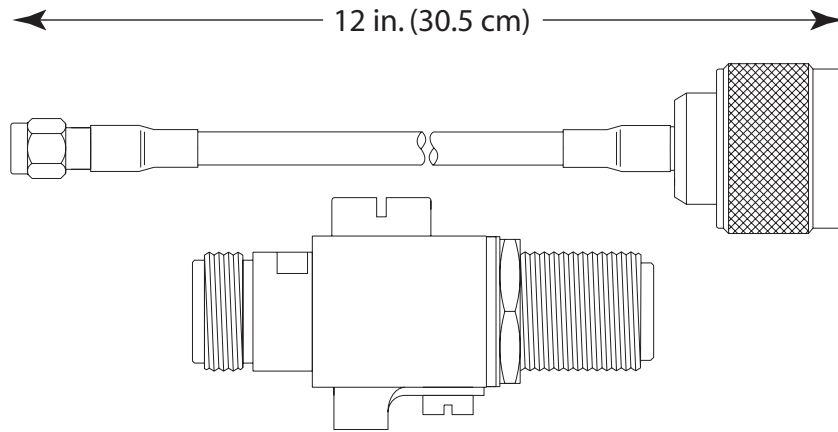

ML-2452-LAK1-01R

<i>Cable</i>	Black, Ultralink, RG-58
<i>Connectors - Cable</i>	N (m) to RP. SMA (m)
<i>Frequency</i>	100-6000 MHz
<i>Insertion Loss - Cable</i>	0.6 @ 2.4 GHz, 1.4 @ 5.5 GHz
<i>Insulation Resistance</i>	50 M-ohms
<i>Connectors - Lightning Arrestor</i>	Type N (f) to N (f)
<i>Weight</i>	4.5 oz
<i>Operating Temperature</i>	- 40° to 85°C
<i>Insertion Loss - Lightning Arrestor</i>	0.14 @ 2.4 GHz, 0.35 @ 5.5 GHz

9

Mounting Kits

9.1 Mounting Kit Support

Motorola Solutions supports mounting kits to support your unique access point or access port deployment. Check the Motorola Solutions Web site periodically, as new kits will be added to this document as they are released. For more information, go to <http://supportcentral.motorola.com/support/product/manuals.do>.

For detailed information on supported mounting kits refer to:

- [ML-1499-SD3MK-01R Articulating I-Beam Mount Kit for ML-2499-SD3-01 Omni Antenna](#)

9.1.1 ML-1499-SD3MK-01R Articulating I-Beam Mount Kit for ML-2499-SD3-01 Omni Antenna

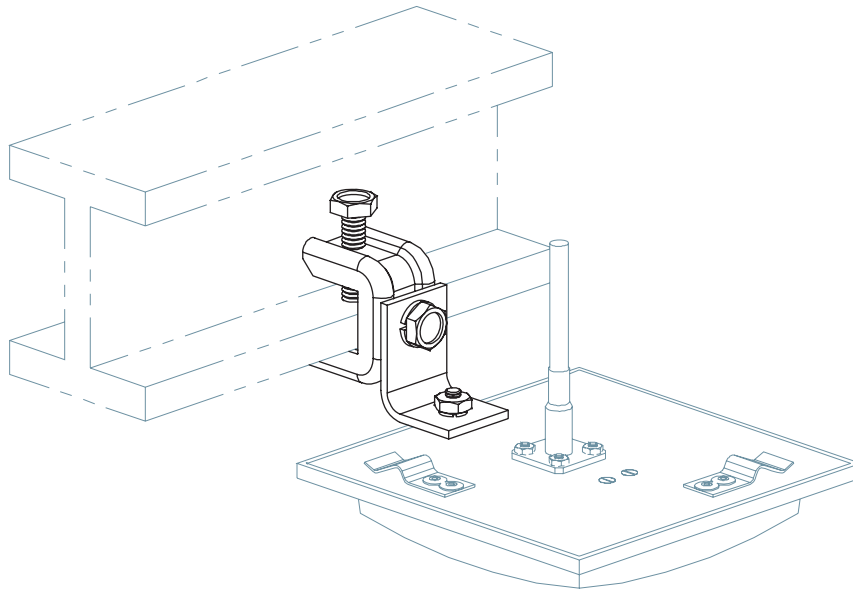

<i>Functionality</i>	Mounts Part No. ML-2499-SD3-01 to an I-beam.
----------------------	--

10

AP-5131 Antenna Connections

This chapter describes how the 2.4 and 5 GHz antennas described within this guide are physically connected to an AP-5131 model access point. Central in this discussion are descriptions of the single and dual-band antennas supported, their supported connector models and how lightning arrestors are supported for specific antenna and connector combinations. For more information, see:

- [2.4 GHz AP-5131 Antenna Connections](#)
- [5 GHz AP-5131 Antenna Connections](#)



NOTE: This chapter references ML-1499-RBNCA1-01R, ML-1499-100JK-01R, ML-1499-72PJ-01R, ML-1499-RBNCA2-01R, 25-116485-01R, ML-2452-APA6J-01 and ML-2499-BPDA1-01R as supported adapters, cables and antennas. These parts are now obsolete, and no longer available from Motorola Solutions. However, these part numbers display within the artwork in this chapter in deployment scenarios with supported parts and can be ignored.

P/N	Length	Conn 1	Conn 2	Attn 2.4	Attn 5.5
25-72178-01	3.1 in.	RSMA-m	RBNC-f	0.2	N/A
25-85391-01R	3.5 in	RSMA-m	N-m	0.2	0.3
25-85392-01R	3.5 in	RSMA-m	N-f bulkhead	0.2	0.3
25-90262-01R	3.55 in.	RSMA-f	N-f bulkhead	0.2	0.3
25-90263-01R	3.55 in.	RSMA-f	N-m	0.2	0.3
25-97261-01R	48 in.	N-m	RBNC-m	1.5	N/A
25-99175-01R	1.5 in.	N-f	N-f	0.2	0.3
ML-1499-100JK-01R	100 ft	N-m	N-m	10.6	15.5
ML-1499-10JK-01R	10 ft	N-m	N-m	2	2.9
ML-1499-25JK-01R	25 ft	N-m	N-m	2.5	4
ML-1499-50JK-01R	50 ft	N-m	N-m	4.5	7
ML-1499-72PJ-01R	6 ft	RPBNC-f	RBNC-m	2.3	N/A
ML-1499-LAK1 Cable	12 in.	N-m	RBNC-m	0.6	N/A
ML-1499-LAK1/2 Arrestor	2.25 in	N-f	N-f	0.24	N/A
ML-1499-LAK2 Adapter	1.5 in.	N-m	N-m	0.15	N/A
ML-1499-RBNCA1-01R	1 ft	N-f	RBNC-f	0.85	N/A
ML-1499-RBNCA2-01R	1 ft	N-m	RBNC-f	0.85	N/A
ML-2452-LAK1 Arrestor	1.75 in.	N-m	N-m	0.14	0.35
ML-2452-LAK1 Cable	12 in.	N-m	RSMA-m	0.6	1.4



CAUTION: The installation of lightning arrestors (as described in several of the AP-5131 antenna connection scenarios in this chapter) must meet local electrical codes.

10.1 2.4 GHz AP-5131 Antenna Connections

This section describes how the components described within this guide are used collectively in the following AP-5131 installation scenarios supporting the 2.4 GHz band:

- [RP-BNC Male Antenna Installation](#)
- [Type N Male Connector Installation](#)



NOTE: For information on the individual 2.4 GHz antennas approved for use with an AP-5131, see *2.4 GHz Single Band Antenna Suite*.

10.1.1 RP-BNC Male Antenna Installation

Refer to the following for a graphical depiction of the parts and connection options available for cabling an 2.4 GHz AP-5131 model access point using RP-BNC male antennas:

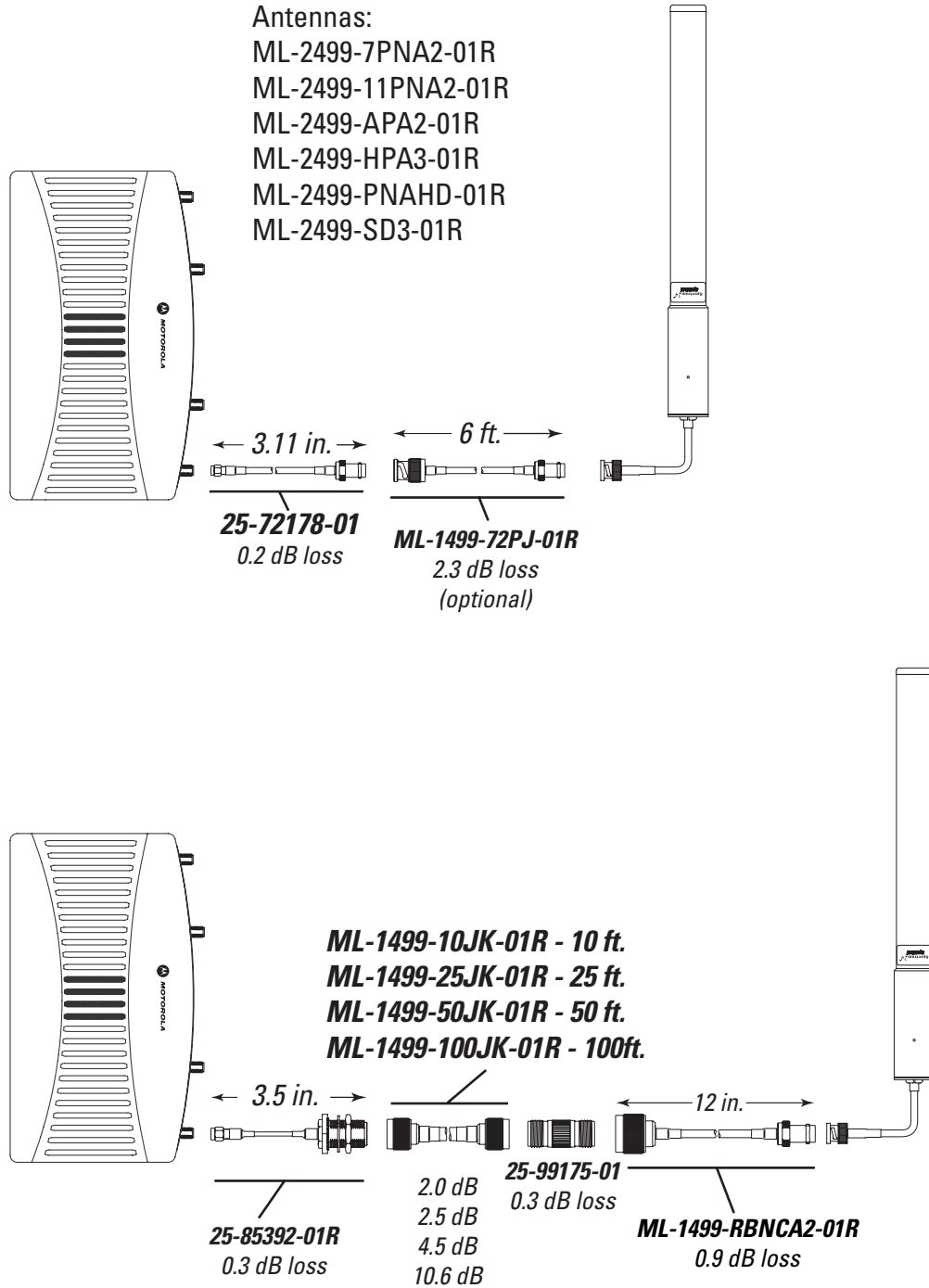

Lightning Aresstor, Antenna side

Antennas:
 ML-5299-PTA1-01R
 ML-5299-WPNA1-01R
 ML-5299-HPA1-01R

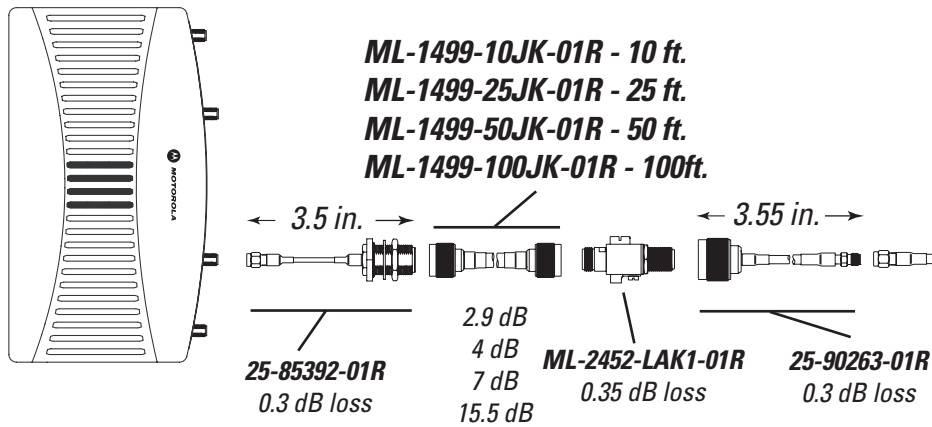

Lightning Aresstor, AP side

Antennas:
 ML-5299-PTA1-01R
 ML-5299-WPNA1-01R
 ML-5299-HPA1-01R

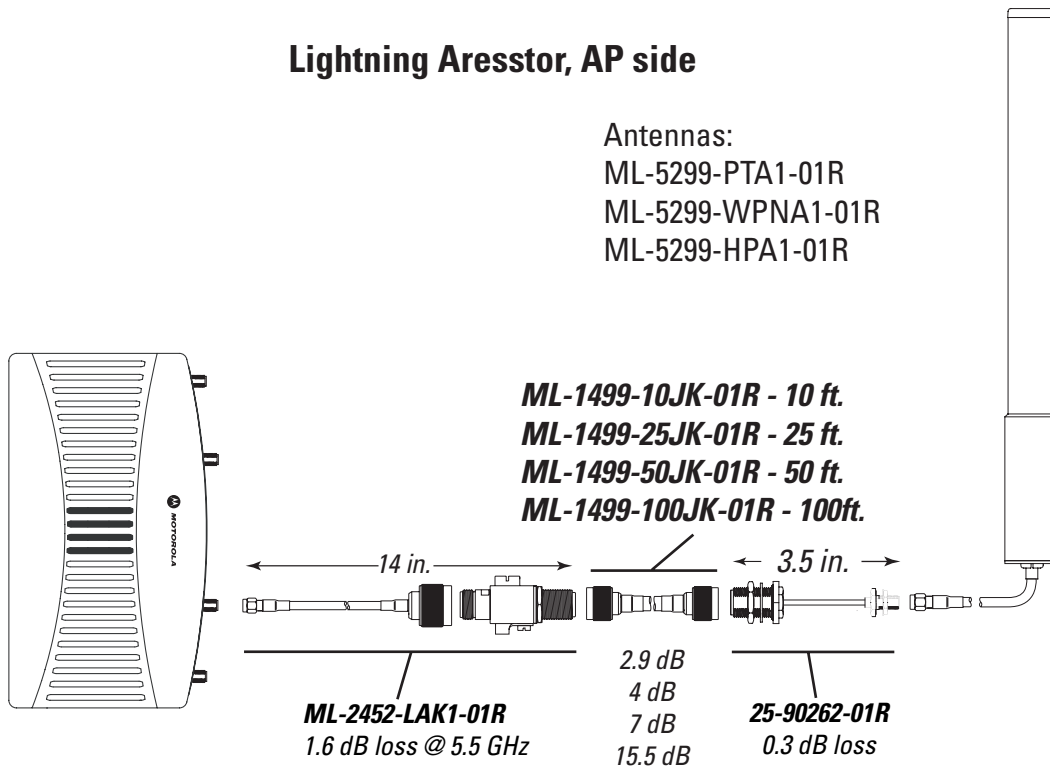

10.1.2 Type N Female Connector Installation

Refer to the following for a graphical depiction of the parts and connection options available for cabling an 2.4 GHz AP-5131 model access point using Type N female connectors:

Antennas:
 ML-2499-BPDA1-01R
 ML-2499-BPNA3-01R
 ML-2499-BYGA2-01R

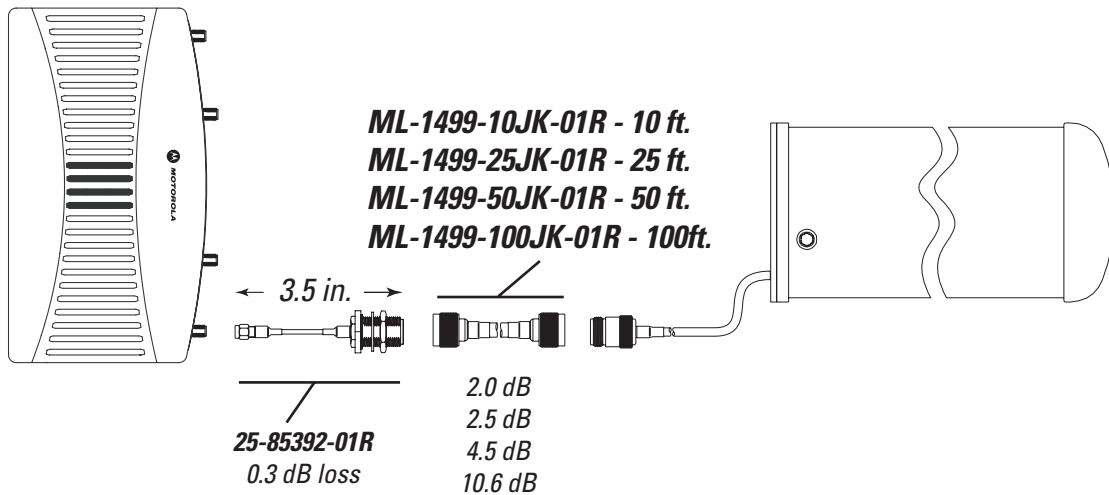
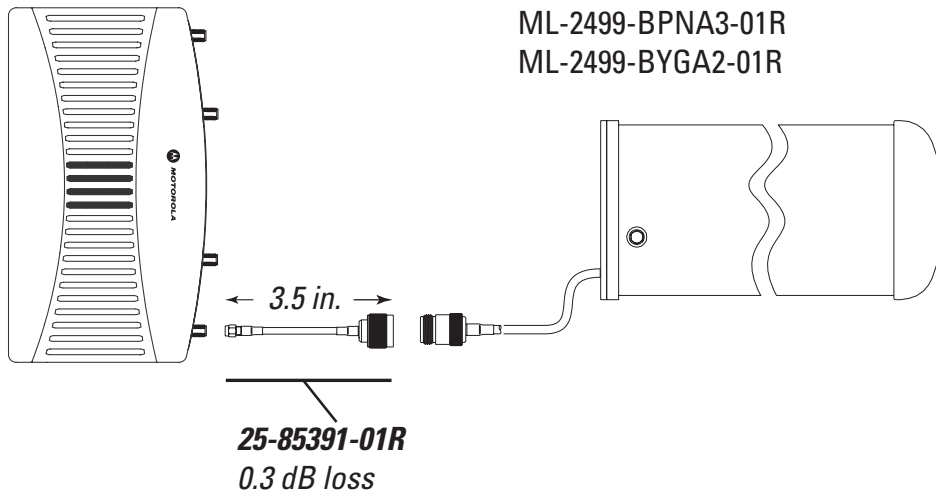

 **CAUTION:** The minimum cable configuration is required to meet regulatory requirements.

Lightning Aresstor, Antenna side

Antennas:
 ML-2499-BPDA1-01R
 ML-2499-BPNA3-01R
 ML-2499-BYGA2-01R

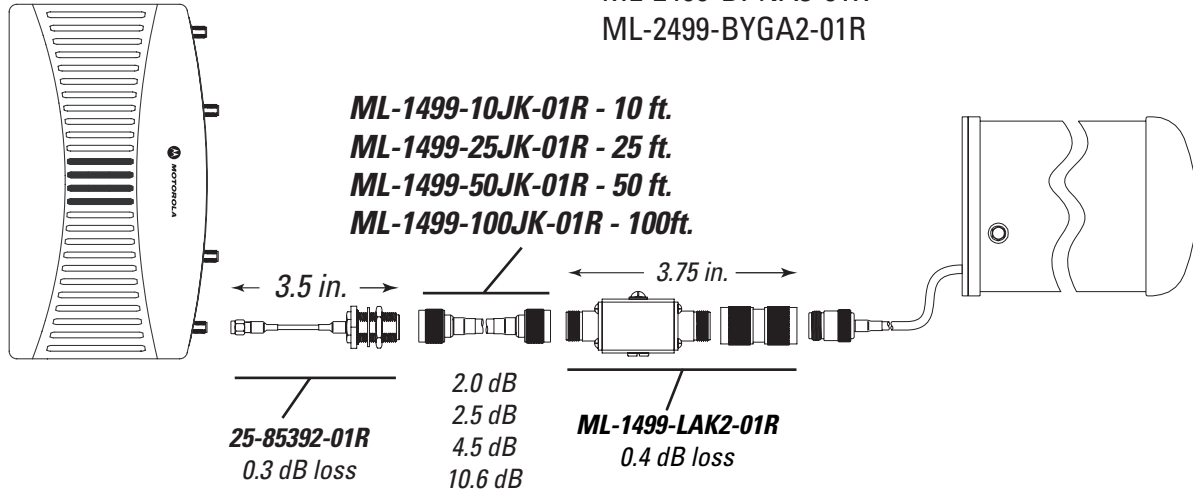

Lightning Aresstor, AP side

Antennas:
 ML-2499-BPDA1-01R
 ML-2499-BPNA3-01R
 ML-2499-BYGA2-01R

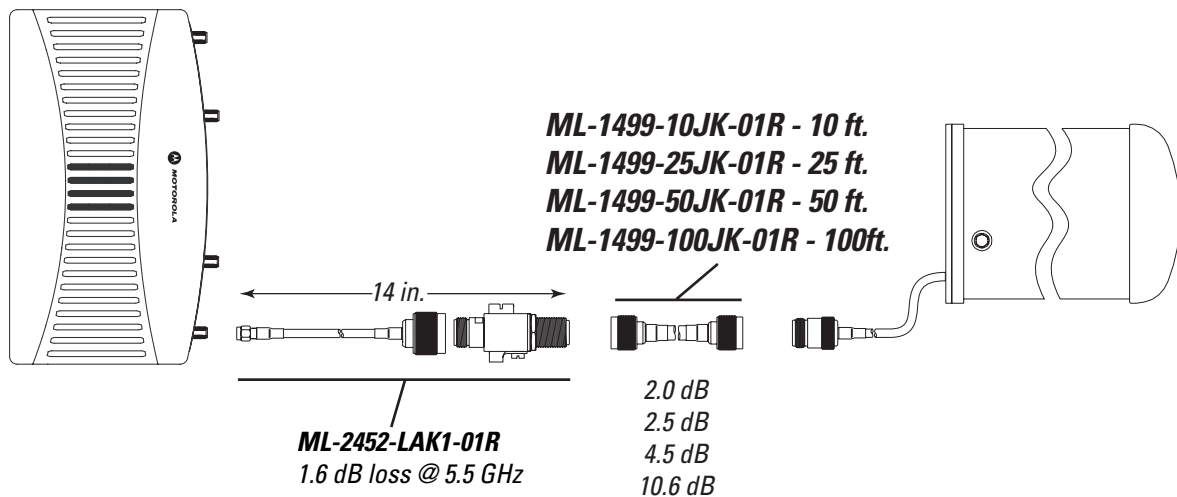

10.1.3 Type N Male Connector Installation

Refer to the following for a graphical depiction of the parts and connection options available for cabling an 2.4 GHz AP-5131 model access point using Type N male connectors:

Antennas:
 ML-2499-5PNL-72-N
 ML-2499-FHPA5-01R
 ML-2499-FHPA9-01R

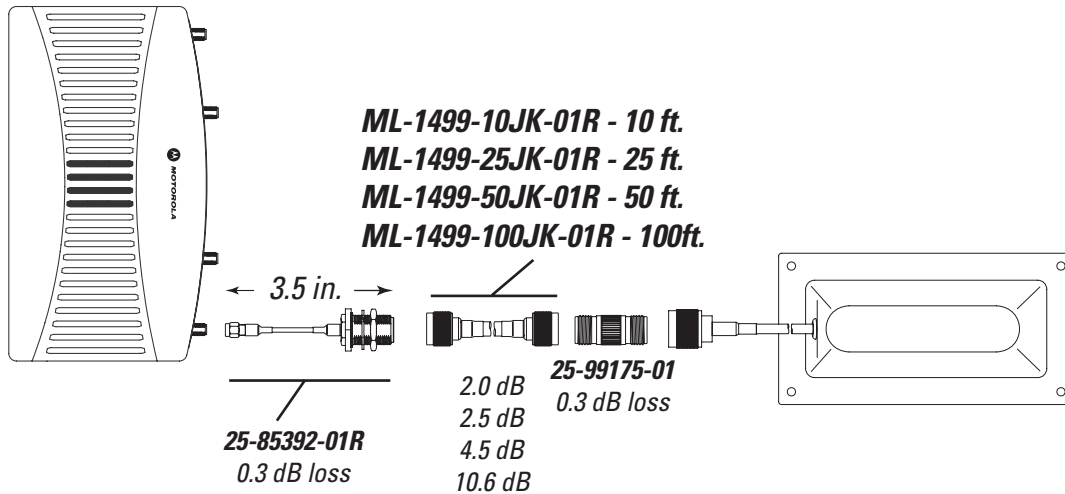

Antennas:
 ML-2499-5PNL-72-N
 ML-2499-FHPA5-01R
 ML-2499-FHPA9-01R

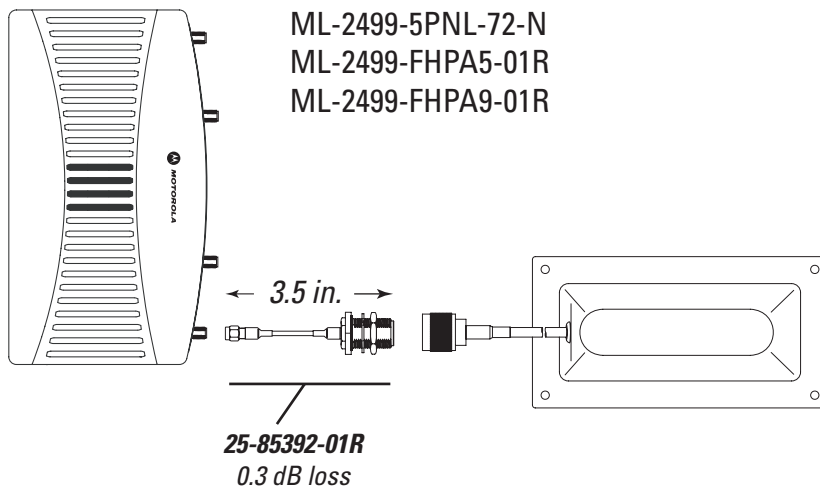

Antennas:
ML-2499-HPA3-01R

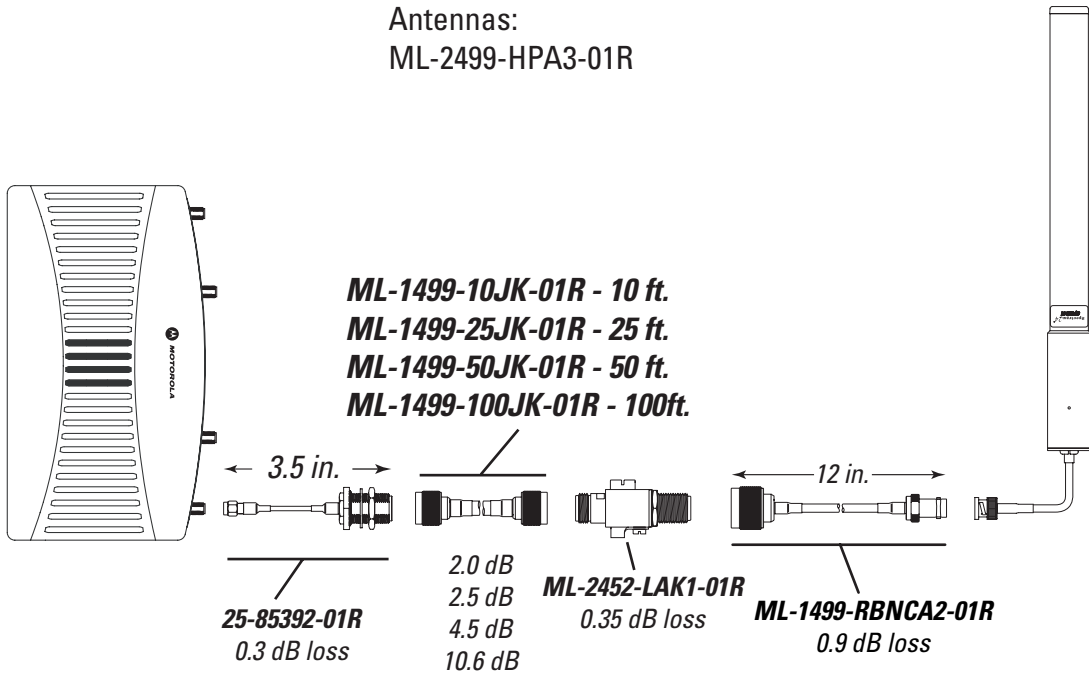

Lightning Arrestor, AP side

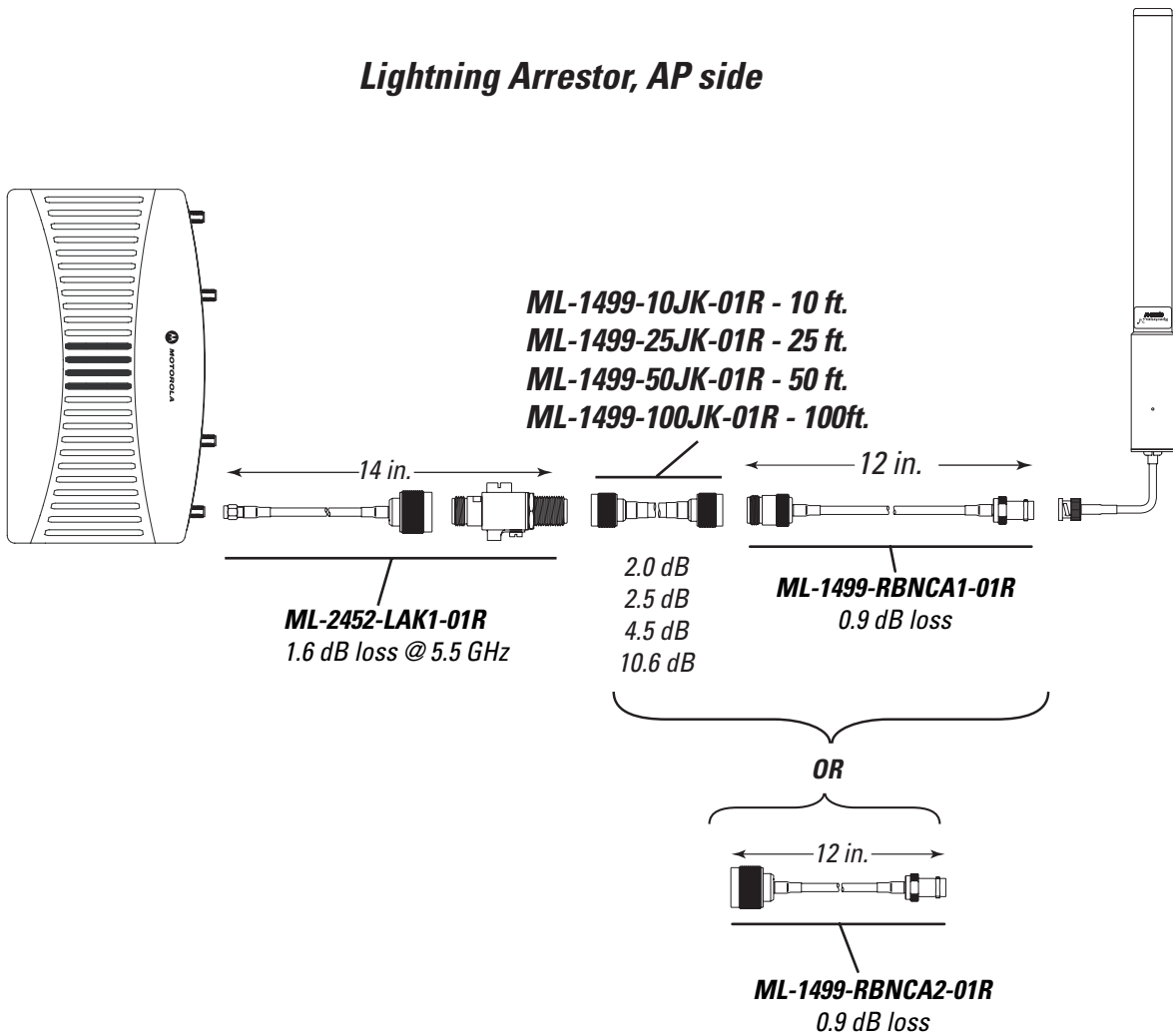

10.2 5 GHz AP-5131 Antenna Connections

This section describes how the components described within this guide are used collectively in the following AP-5131 installation scenarios supporting the 5 GHz band:

- [RP-SMA Male Antenna Installation](#)
- [Type N Male Connector Installation](#)



NOTE: For information on the individual 5 GHz antennas approved for use with an AP-5131, see *5.2 Ghz Single Band Antenna Suite*.

10.2.1 RP-SMA Male Antenna Installation

Refer to the following for a graphical depiction of the parts and connection options available for cabling an 5 GHz AP-5131 model access point using a RP-SMA male antenna (with no lightning arrestor):

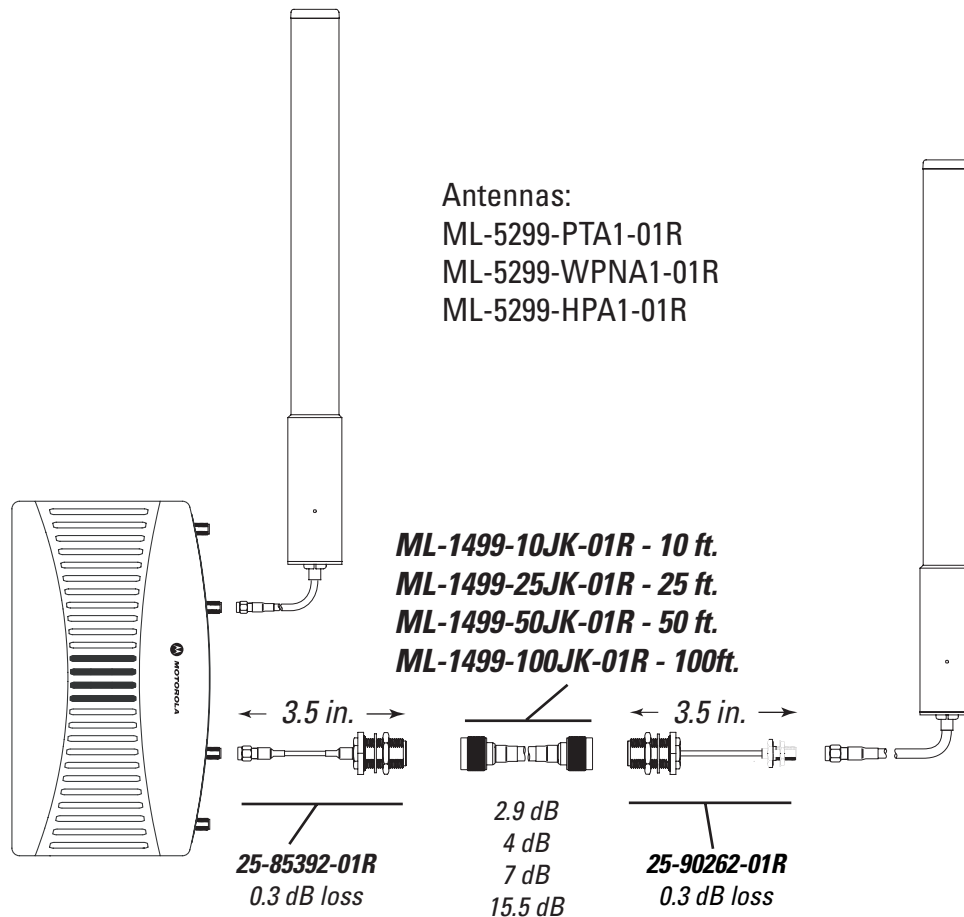

Refer to the following for a graphical depiction of the parts and connection options available for cabling an 5 GHz AP-5131 model access point using a RP-SMA male antenna (with a lightning arrestor):

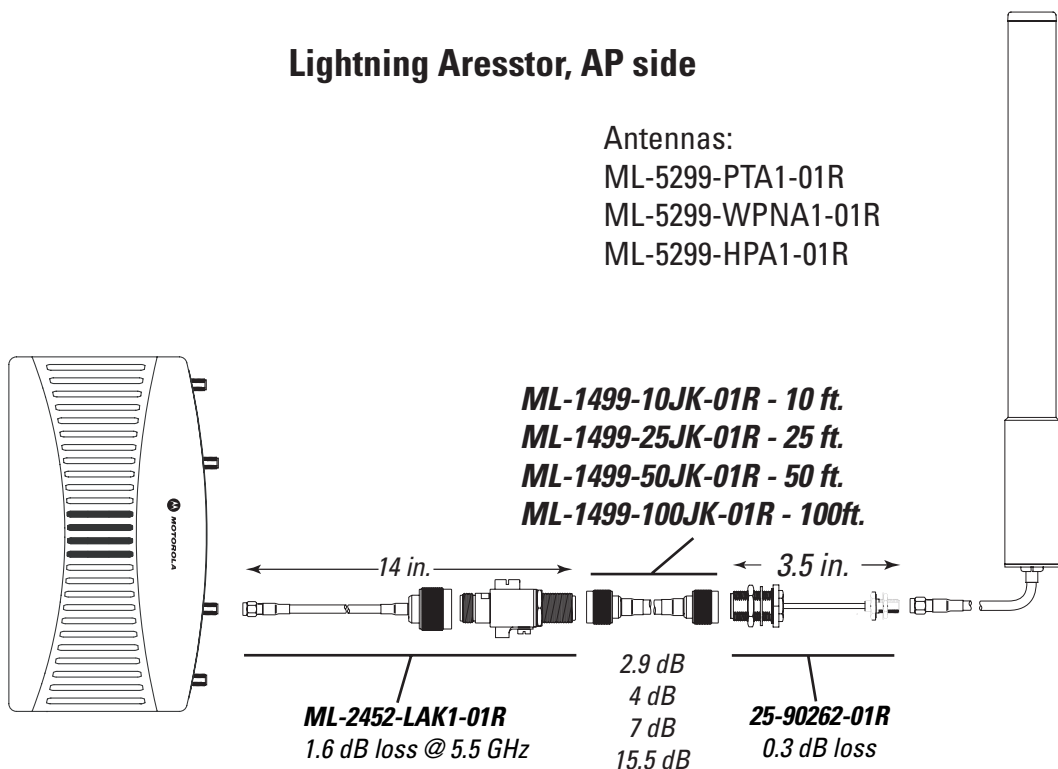
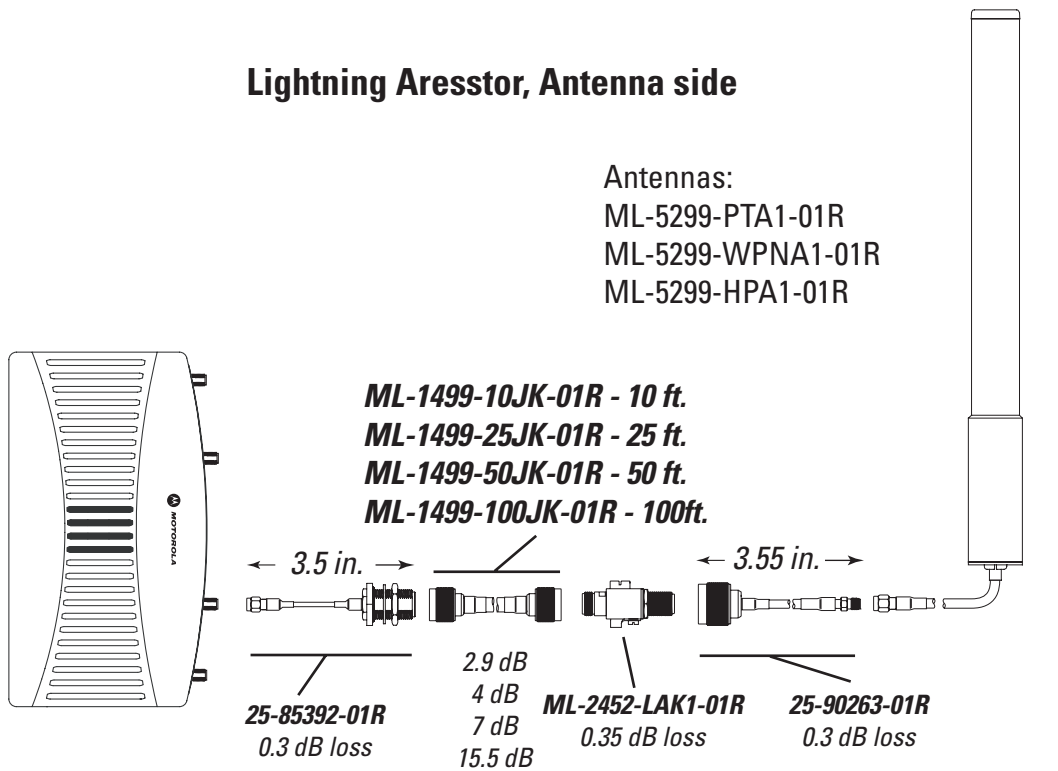

10.2.2 Type N Male Connector Installation

Refer to the following for a graphical depiction of the parts and connection options available for cabling an 5 GHz AP-5131 model access point using Type N male connectors:

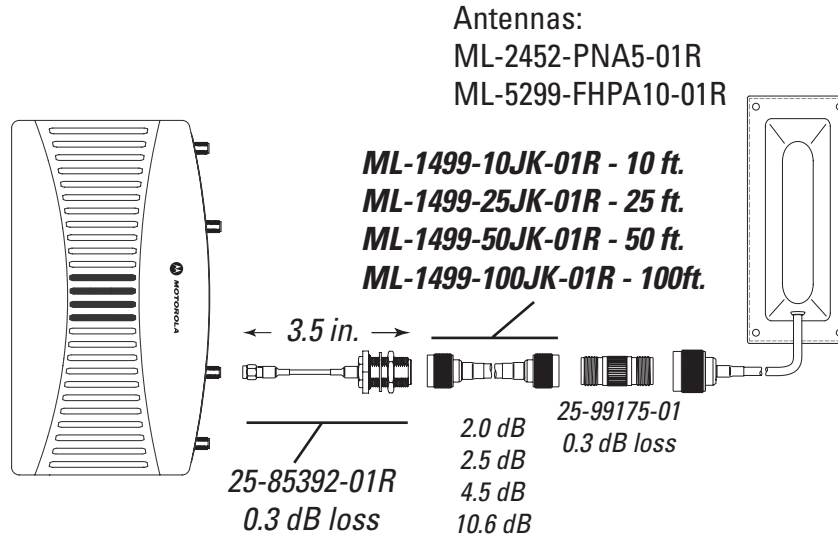

Lightning Aresstor, Antenna side

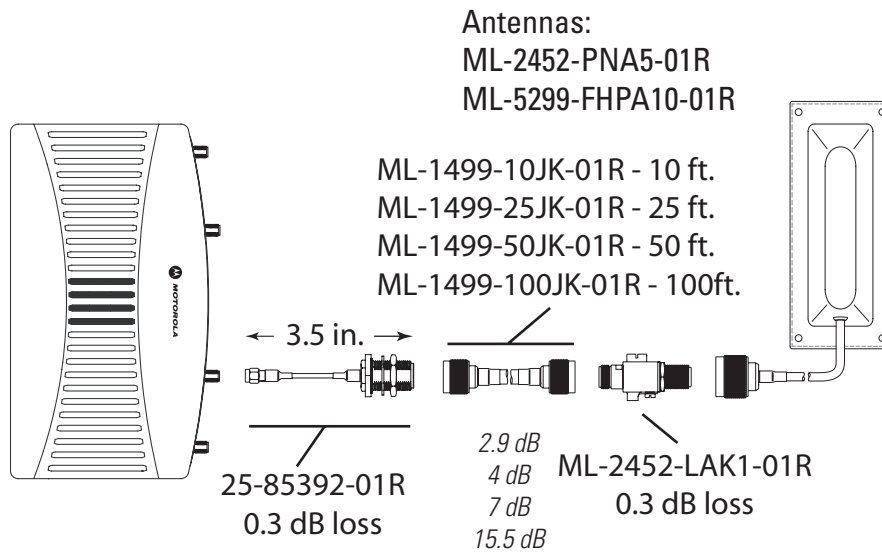

Lightning Aresstor, AP side

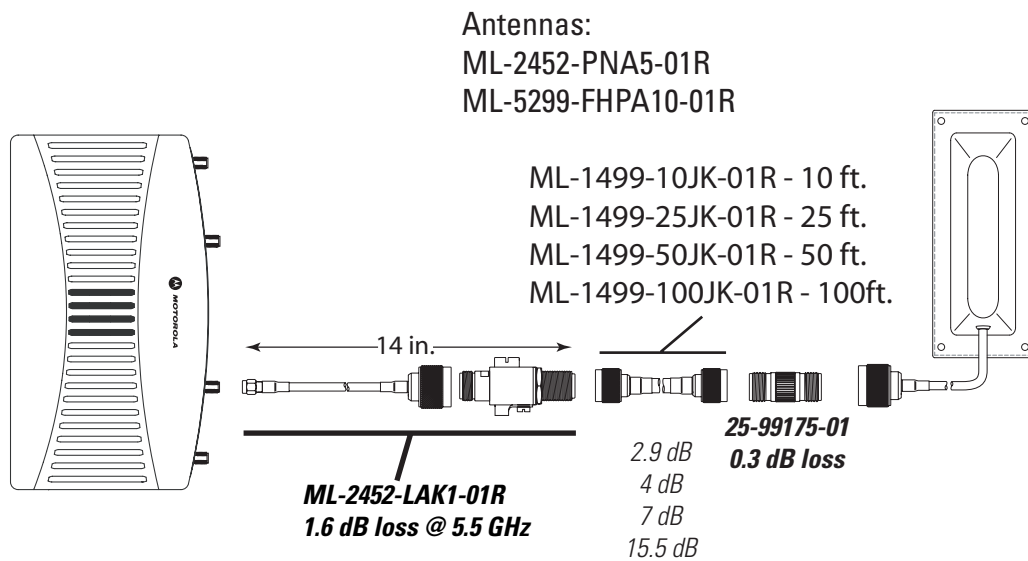

AP300 Antenna Connections

This chapter describes how the 2.4 and 5 GHz antennas described within this guide are physically connected to an AP300 model access port. The information in this chapter supports an AP300 external antenna model only.



NOTE: This chapter references ML-1499-100JK-01R, ML-1499-72PJ-01R, ML-1499-RBNCA2-01R, 25-116485-01R, ML-2452-APA6J-01 and ML-2499-BPDA1-01R as supported adapters, cables and antennas. These parts are now obsolete, and no longer available from Motorola Solutions. However, these part numbers display within the artwork in this chapter in deployment scenarios with supported parts and can be ignored.



CAUTION: The installation of lightning arrestors (as described in several of the AP300 antenna connection scenarios in this chapter) must meet local electrical codes.

For more information, see:

- [2.4 GHz AP300 Antenna Connections](#)
- [5 GHz AP300 Antenna Connections](#)

11.1 2.4 GHz AP300 Antenna Connections

This section describes how the components described within this guide are used collectively in the following AP300 installation scenarios supporting the 2.4 GHz band:

- [RP-BNC Male Antenna Installation](#)
- [Type N Female Connector Installation](#)
- [Type N Male Connector Installation](#)

11.1.1 RP-BNC Male Antenna Installation

Refer to the following for a graphical depiction of the parts and connection options available for cabling an 2.4 GHz AP300 model access port using RP-BNC male antennas:

Antennas:

- ML-2499-7PNA2-01R
- ML-2499-11PNA2-01R
- ML-2499-APA2-01R
- ML-2499-HPA3-01R
- ML-2499-PNAHD-01R
- ML-2499-SD3-01R

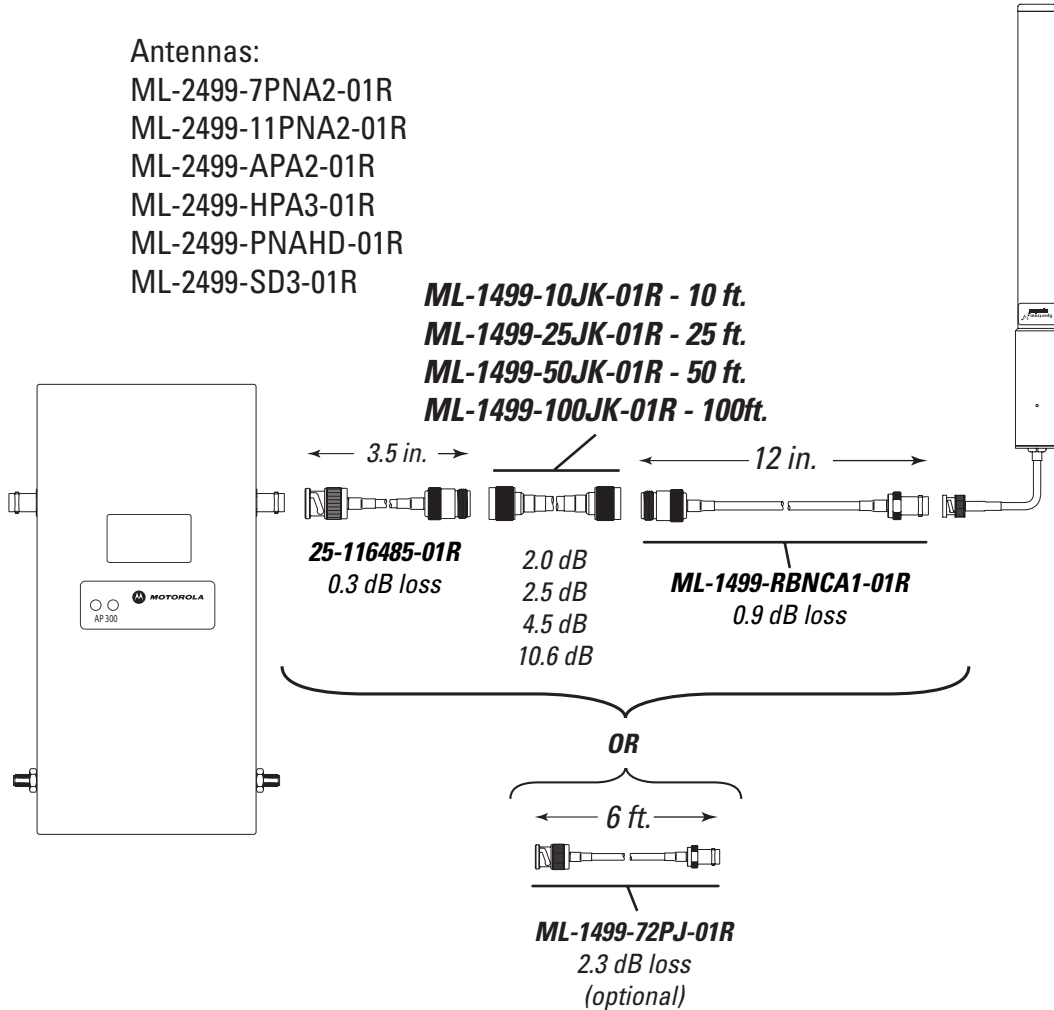

Lightning Arrestor, Antenna side

Antennas:
ML-2499-HPA3-01R

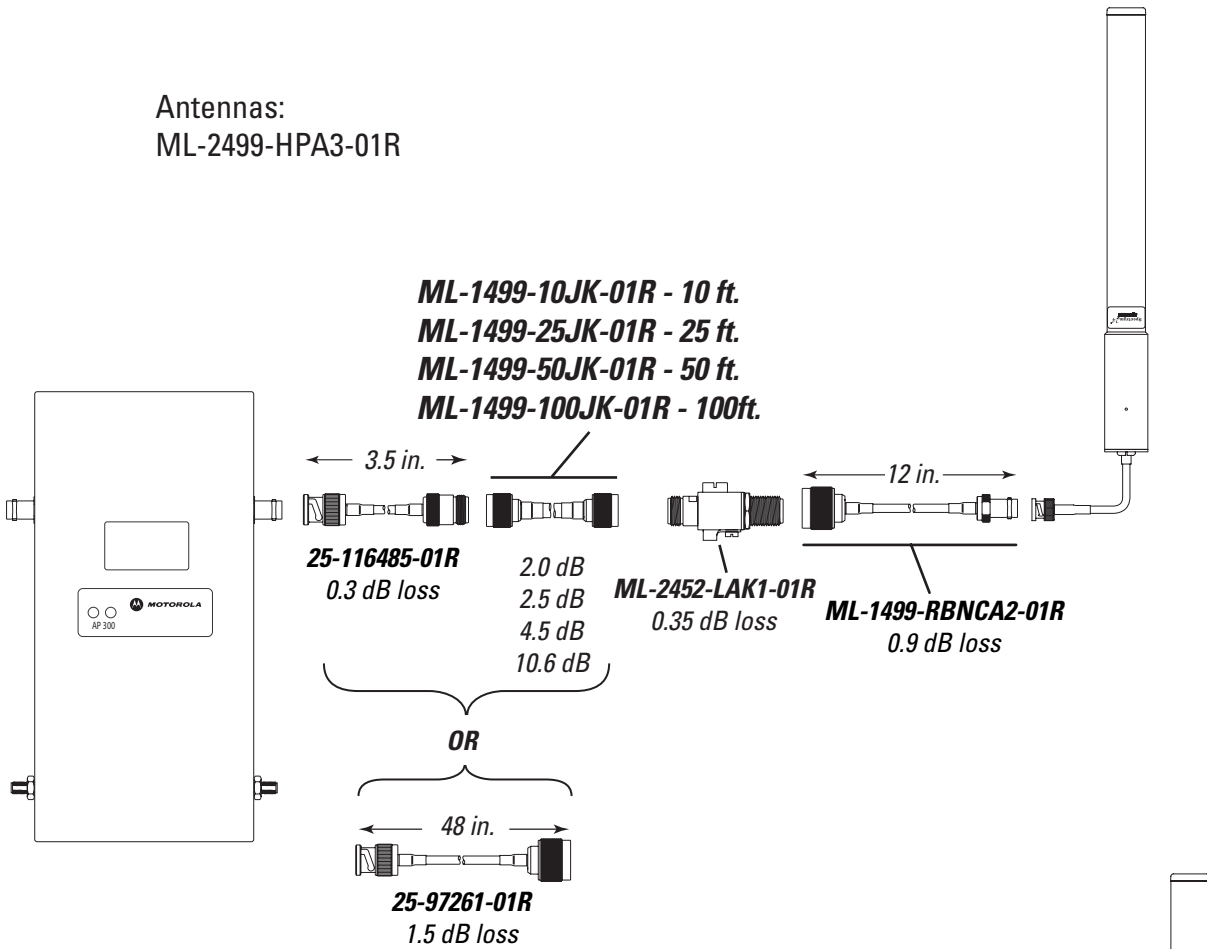

Lightning Arrestor, AP side

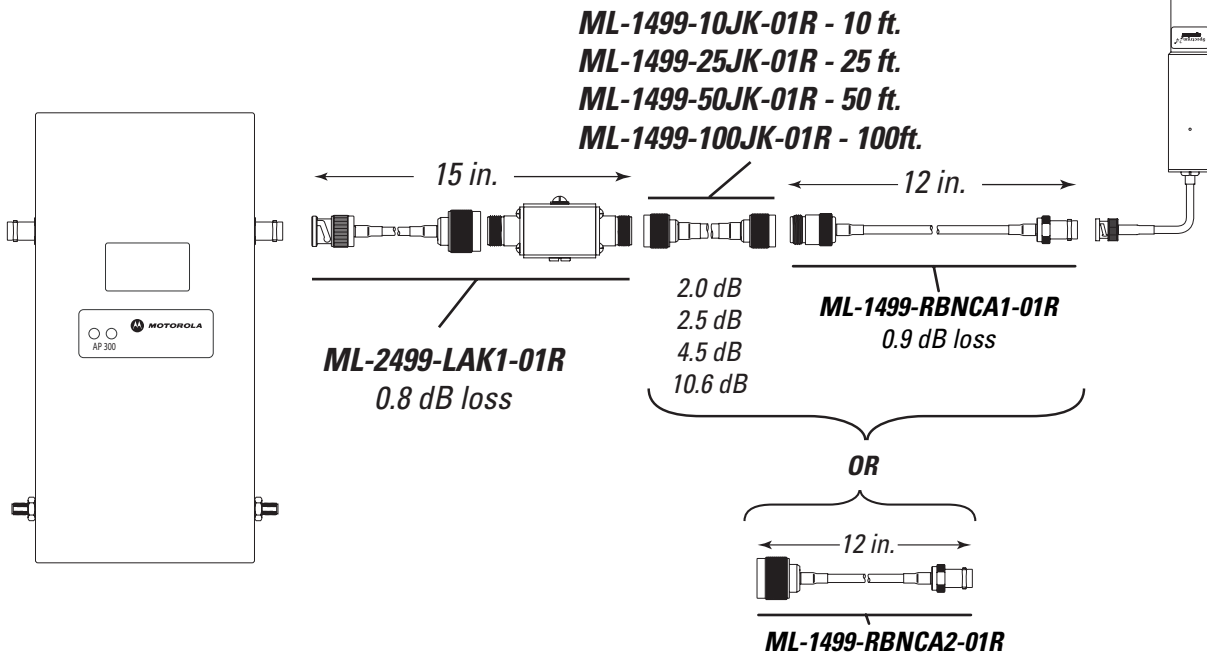

11.1.2 Type N Female Connector Installation

Refer to the following for a graphical depiction of the parts and connection options available for cabling an 2.4 GHz AP300 model access port using Type N female connectors.

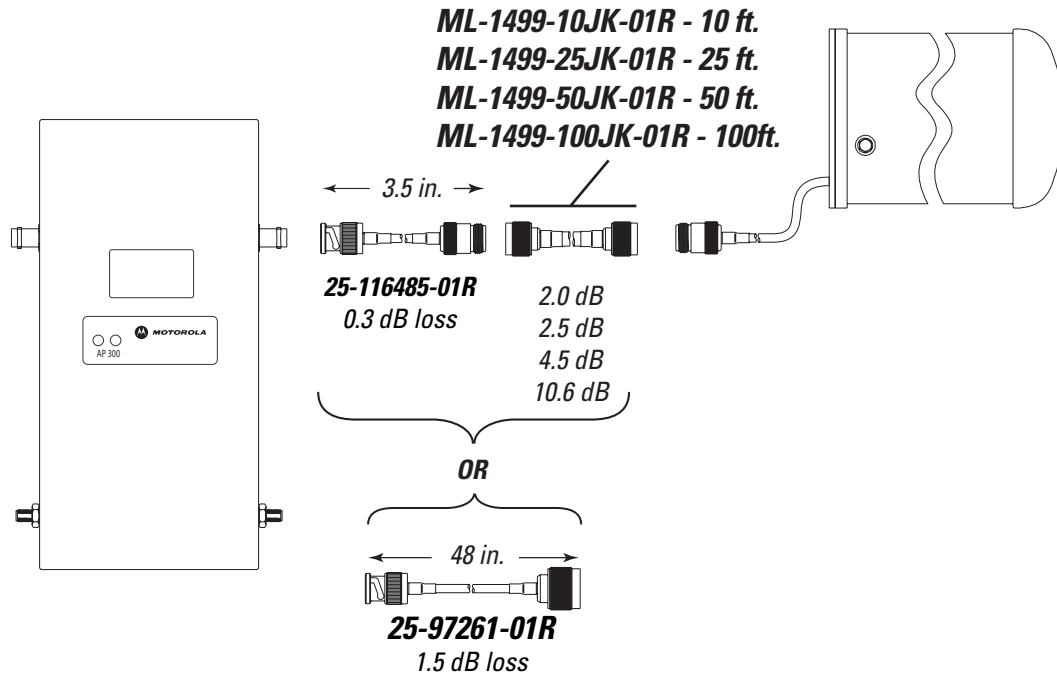

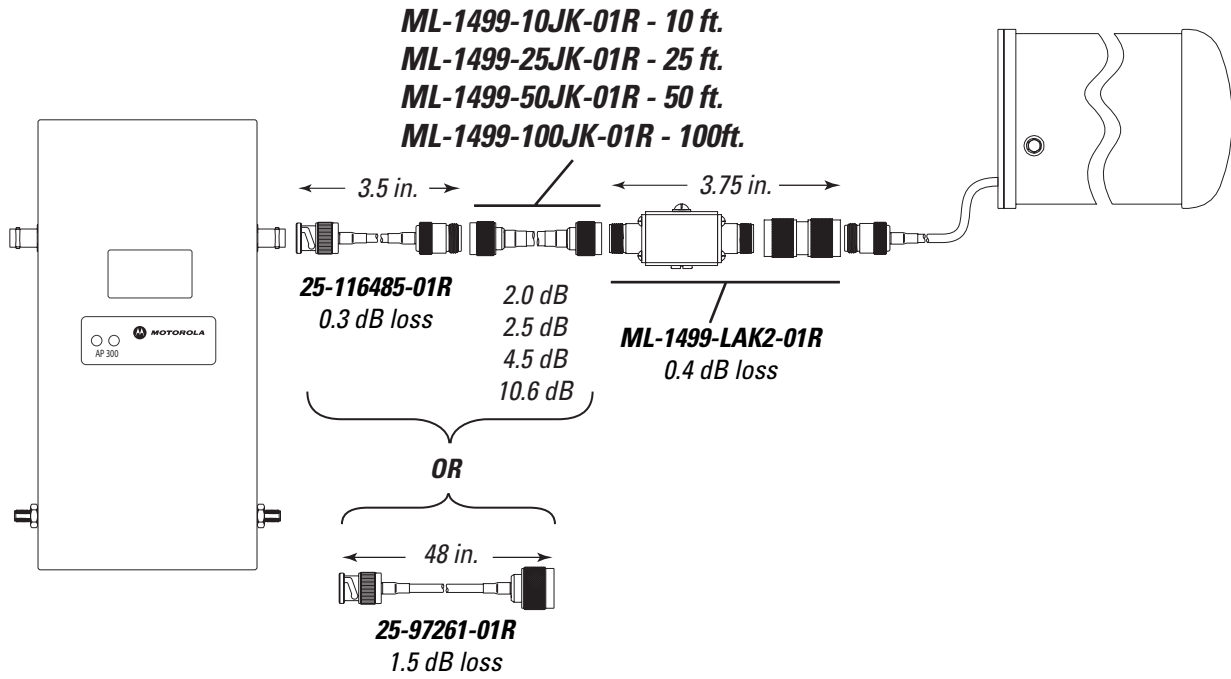

Lightning Aresstor, AP side

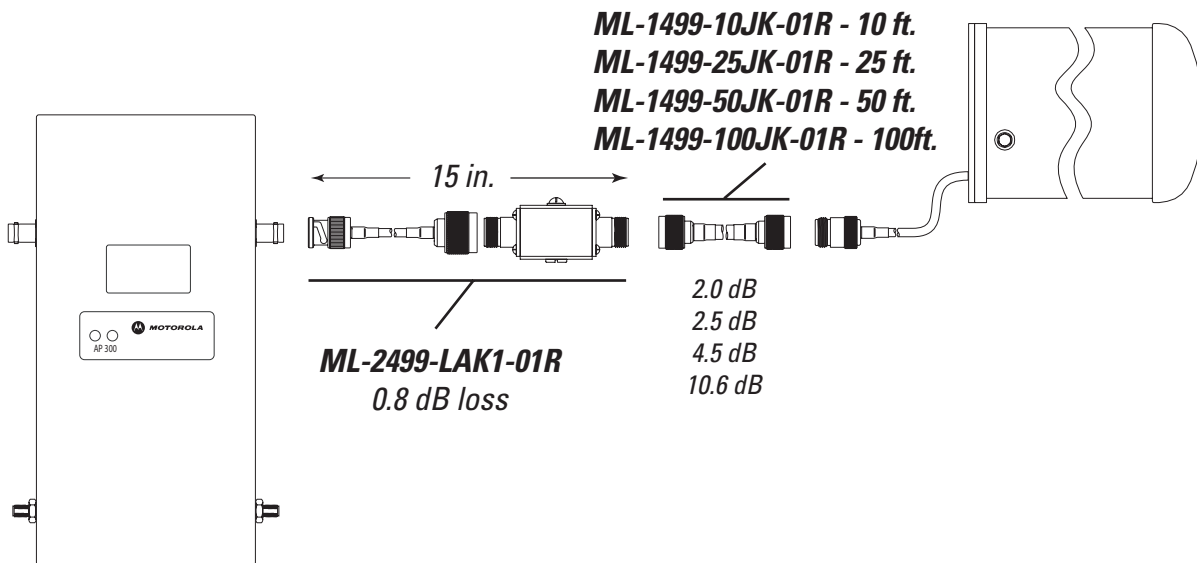

11.1.3 Type N Male Connector Installation

Refer to the following for a graphical depiction of the parts and connection options available for cabling an 2.4 GHz AP300 model access port using Type N male connectors:

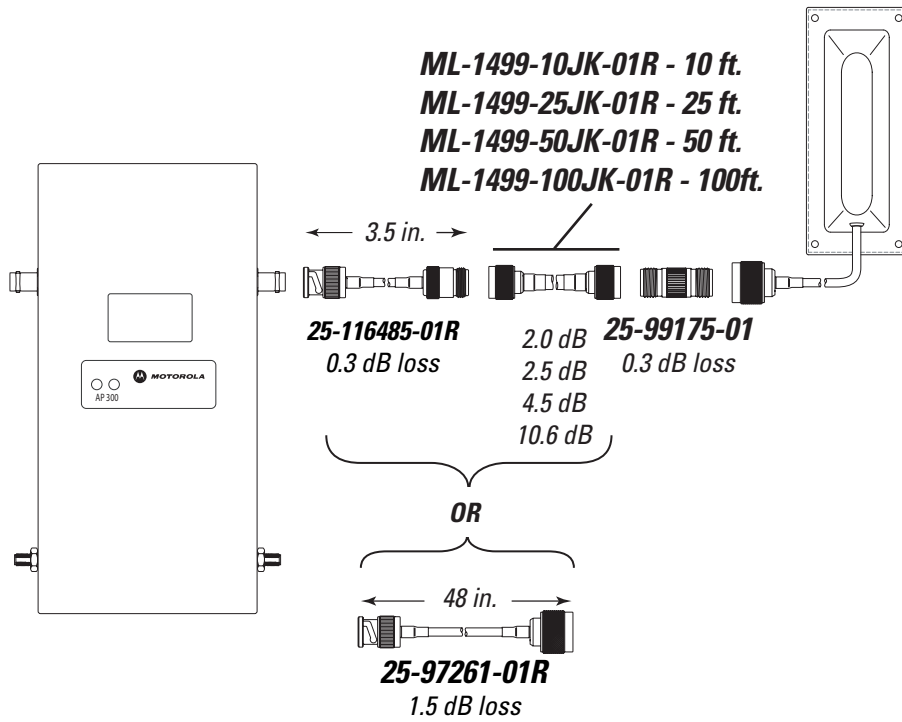

Lightning Arrestor, Antenna side

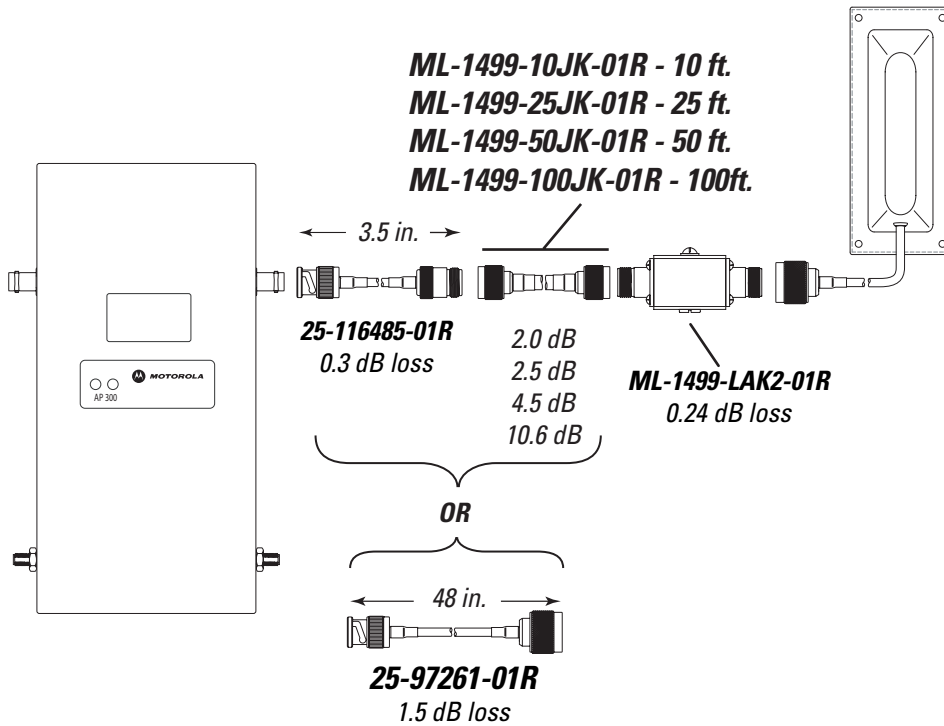

Lightning Arrestor, AP side

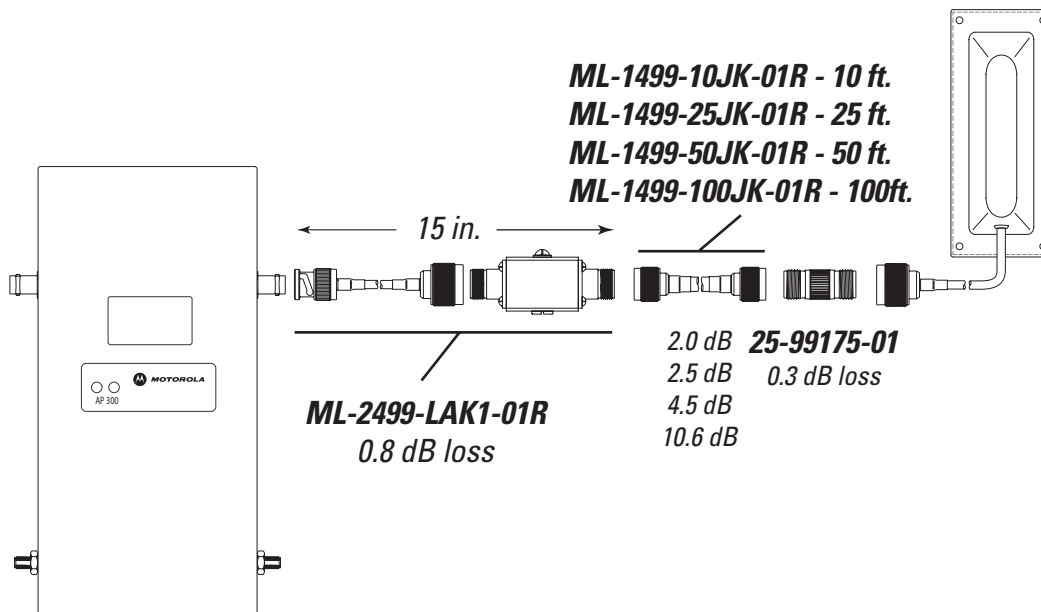

11.2 5 GHz AP300 Antenna Connections

This section describes how the components described within this guide are used collectively in the following AP300 installation scenarios supporting the 5 GHz band:

- [RP-SMA Male Antenna Installation](#)
- [Type N Male Connector Installation](#)

11.2.1 RP-SMA Male Antenna Installation

Refer to the following for a graphical depiction of the parts and connection options available for cabling an 5 GHz AP300 model access port using a RP-SMA male antenna.

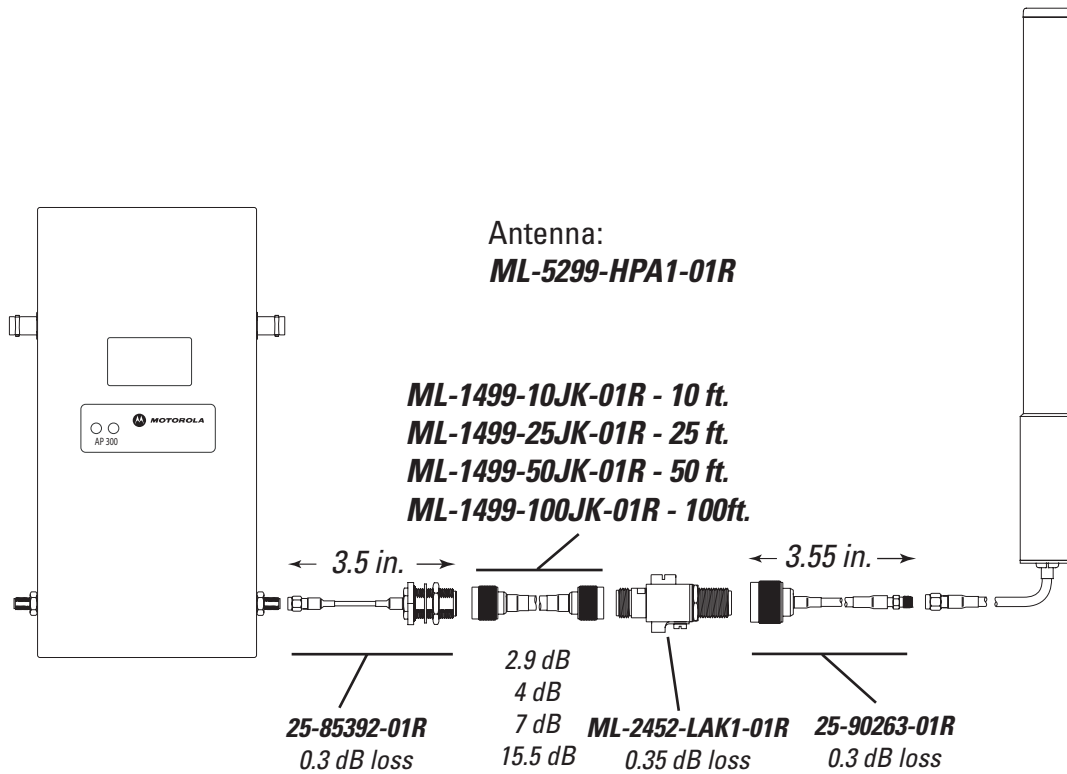

Lightning Aresstor, Antenna side

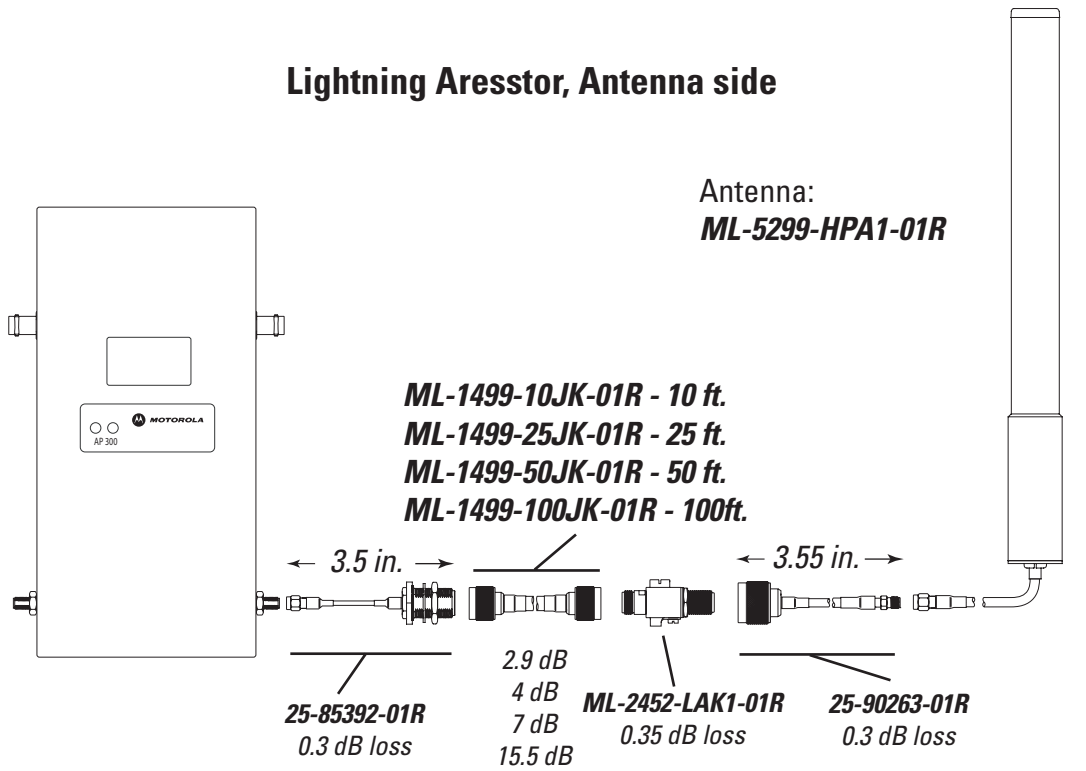

Lightning Aresstor, AP side

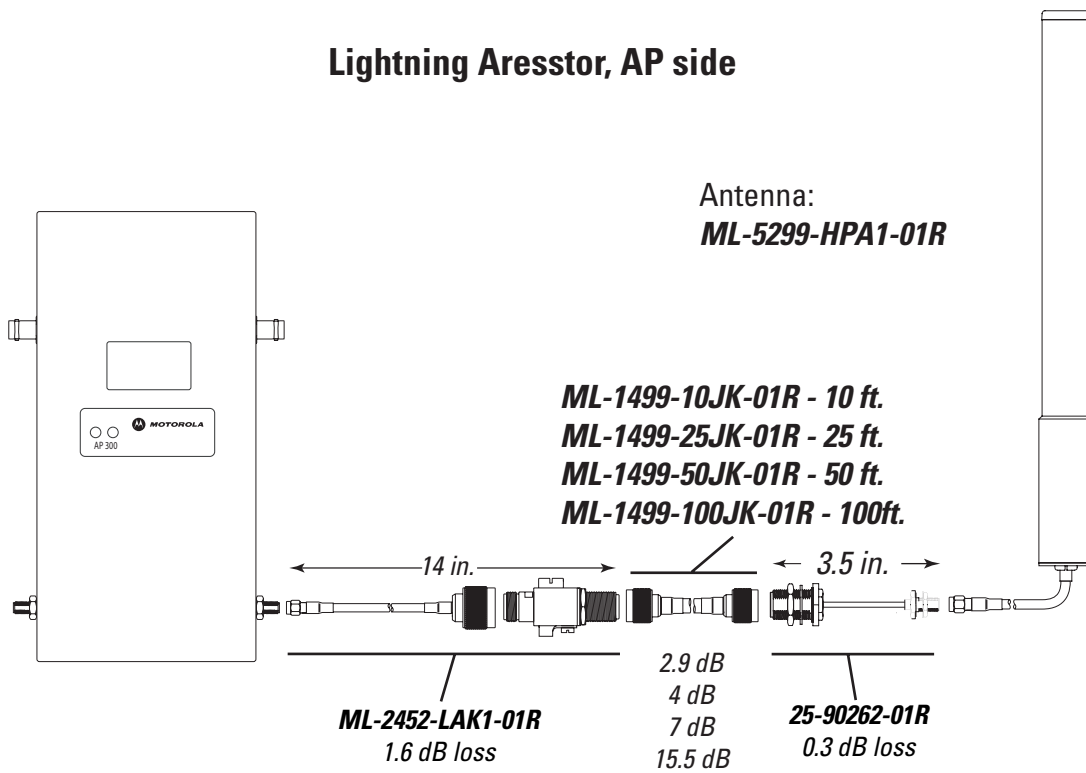

11.2.2 Type N Male Connector Installation

Refer to the following for a graphical depiction of the parts and connection options available for cabling an 5 GHz AP300 model access port using Type N male connectors:

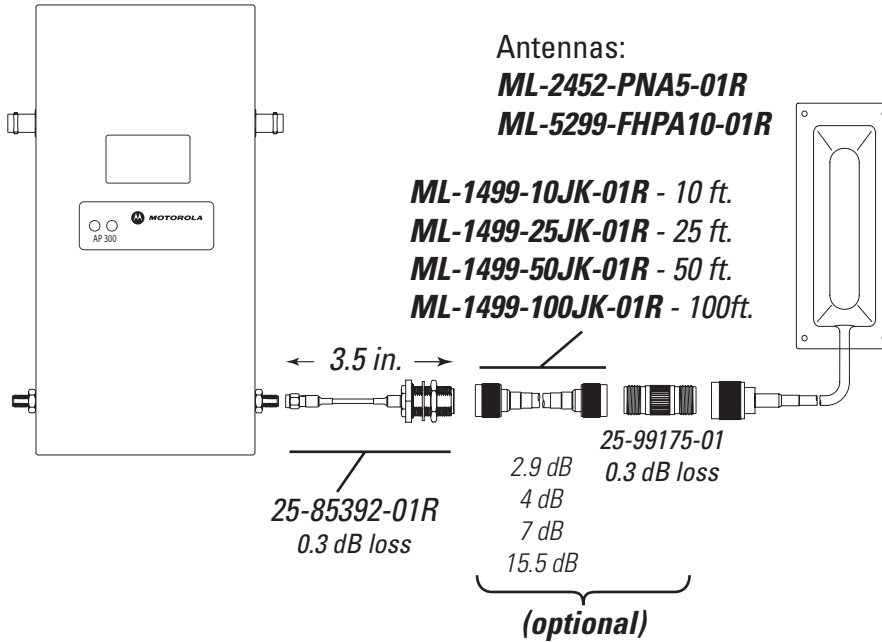

Lightning Aresstor, Antenna side

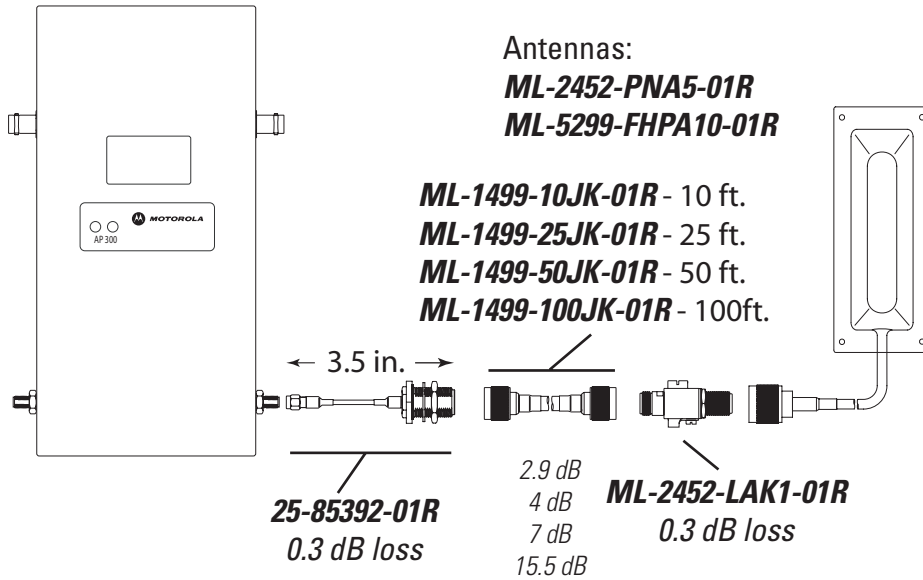

Lightning Aresstor, AP side

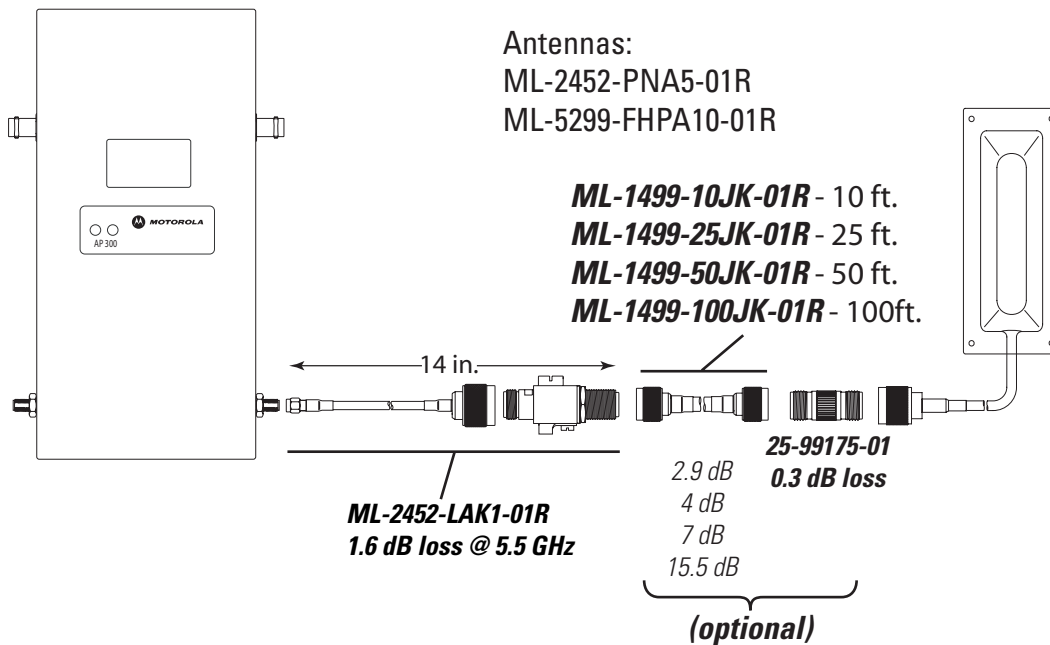

12

AP7131 Transmit Power

12.1 Configuring the AP7131 Series Transmit Power

Professional installers must configure an AP7131 series access point so it does not violate FCC regulations pertaining to output transmit power.

This chapter describes how to adjust an AP7131 series access point's radio transmit power.



NOTE: Motorola Solutions assumes the AP7131 series access point radio and power configuration activities described in this chapter are conducted at the location that access point is actually installed and deployed.

To define an AP7131 series access point's radio transmit power:

1. Complete the physical installation of the AP7131 series access point following one of the supported mounting options within either the *AP7131 Series Installation Guide* or *Product Reference Guide*. Both guides are available at <http://supportcentral.motorola.com/support/product/manuals.do>.

An AP7131 series access point can attach to a wall, mount under a suspended T Bar or above a ceiling (plenum or attic) following the same installation instructions. Choose a mounting option based on the physical environment of the coverage area. Do not mount the access point in a location that has not been approved in a site survey.

2. Start a browser and enter the access point's default static IP address for the WAN port (10.1.1.1).
3. Initially log in using **admin** as the default Username and **motorola** as the default Password. Use your new password if it has been updated from default.

If the default login is successful, the **Change Admin Password** window displays. Change the password immediately to ensure secure access.

4. Select **System Configuration > Quick Setup** from the menu tree.

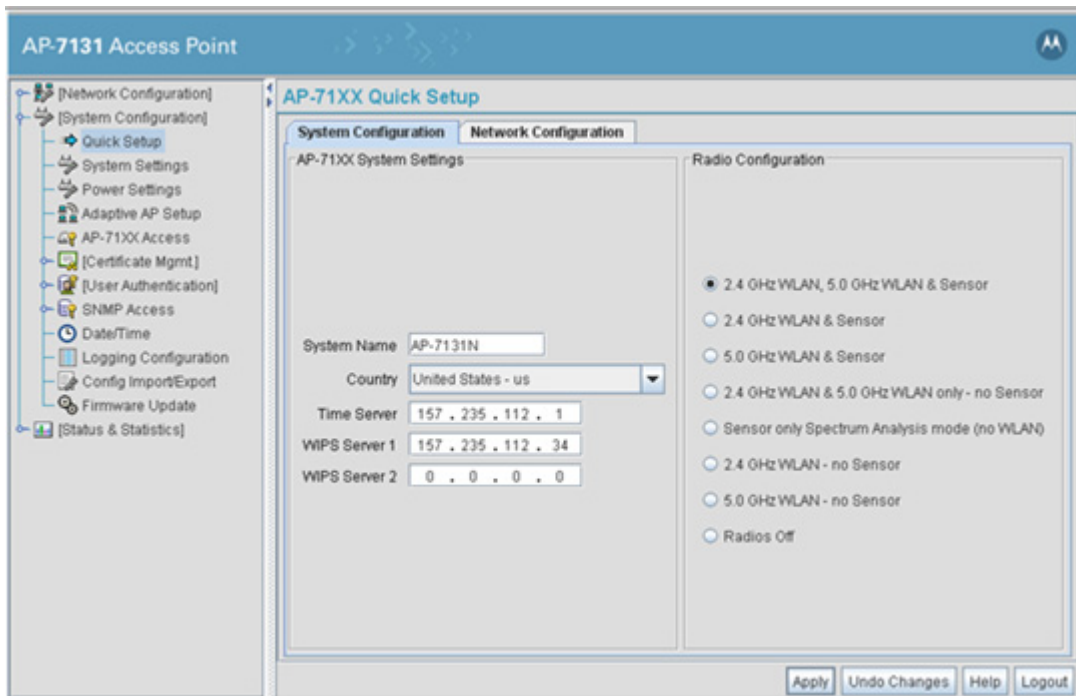

5. Select the **System Configuration** tab to define the access point's country code and radio configuration.
6. Select the **Country** for the access point's country of operation.

The access point prompts for the correct country code on the first login. A warning message also displays stating an incorrect country setting may result in illegal radio operation. Selecting the correct country is central to legally operating the access point. Each country has its own regulatory restrictions concerning electromagnetic emissions and the maximum RF signal strength that can be transmitted. To ensure compliance with national and local laws, set the country accurately.



NOTE: If the access point is a US supported model, the country code is automatically set to US.

7. Refer to the **Radio Configuration** field to define how WLAN and WIPS are supported by the access point's radio(s). Remember, the options available depend on the single, dual or three radio model deployed. Apply your settings when finished with the updates.

Radio Button	Single Radio SKU	Dual Radio SKU	Three Radio SKU
2.4 GHz WLAN, 5.0 GHz WLAN & Sensor	Not Available	Not Available	Radio 1 WLAN, Radio 2 WLAN, Radio 3 WIPS
2.4 GHz WLAN, & Sensor	Not Available	Radio1 WLAN, Radio 2 WIPS	Radio 1 WLAN, Radio 2 WIPS, Radio 3 WIPS
5.0 GHz WLAN & Sensor	Not Available	Radio 1 WIPS, Radio 2 WLAN	Radio 1 WIPS, Radio 2 WLAN, Radio 3 WIPS
2.4 GHz WLAN & 5.0 GHz WLAN only no Sensor	Not Available	Radio 1 WLAN, Radio 2 WLAN	Radio 1 WLAN, Radio 2 WLAN, Radio 3 Disabled
Sensor only Spectrum Analysis mode (no WLAN)	Radio 1 WIPS	Radio 1 WIPS, Radio 2 WIPS	Radio 1 WIPS, Radio 2 WIPS, Radio 3 Disabled
2.4 GHz WLAN no Sensor	Radio 1 WLAN (B/G/N)	Radio1 WLAN, Radio 2 Disabled	Radio 1 WLAN, Radio 2 Disabled, Radio 3 Disabled
5.0 GHz WLAN no Sensor	Radio 1 WLAN (A/N)	Radio1 Disabled, Radio 2 WLAN	Radio 1 Disabled, Radio 2 WLAN, Radio 3 Disabled
Radios Off	Radio 1 Disabled	Radios 1 and 2 Disabled	Radios 1, 2 and 3 Disabled

8. Select **System Configuration > Power Settings** from the menu tree.

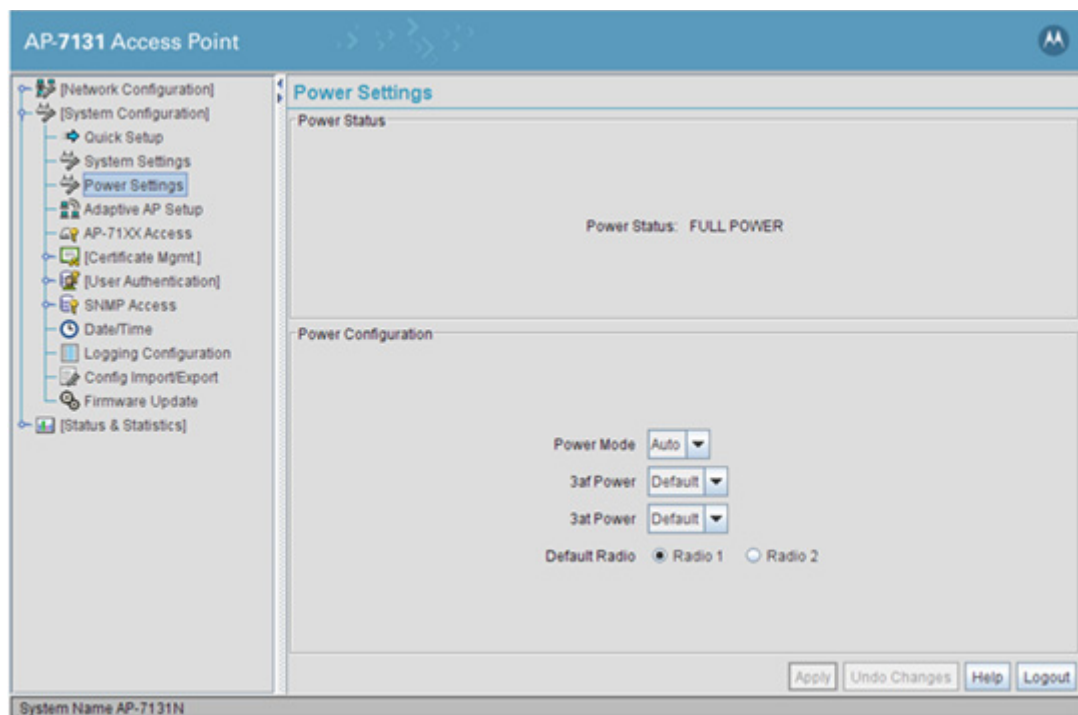

Within the **Power Configuration** field, an installation professional selects a power mode based on the different power resources available to that access point's SKU. For 3af and 3at, choose between **Default** and **Option** as best suited to that hardware SKU. For example, if Option is selected for 3af Power, and the access point is a dual radio model, the following configuration is set:

LAN port ON (1000 BASE T)

WAN port OFF

Radio 1 (2.4) on, 2x3 mode with maximum transmit power 18dBm

Radio 2 (5.0) on, 2x3 mode with maximum transmit power 18dBm

9. For this example, set the Power Mode to **Auto** (if not already defined as Auto by default). Leave the 3af and 3at Power settings as Default.

When the access point is powered on for the first time, the system determines the power budget available to the access point. Using the Auto setting (default setting), the access point automatically determines the best power configuration based on the available power budget. Therefore, the Auto power mode option affords the professional installer a smaller margin of error for legally setting the access point's transmit output power. If changes are made, reboot the access point.



NOTE: Ensure the access point is connected to its expected power supply (3af, 3at or Full Power). Check available access point power by reviewing the Power Status field within the Power Settings screen (this value is cable length dependent). Compare available power to the *Maximum Transmit Power vs POE* table below. If available supply power does not allow the desired transmit power, then increase the supply power.

Maximum Possible Transmit Power

Power Status	2.4 GHz	5.2 GHz
3af	+20	+19
3at	+23	+20
Full Power	+23	+20

10. Select **Network Configuration > Wireless > Radio Configuration > Radio1** or **Radio 2** from the access point menu tree.

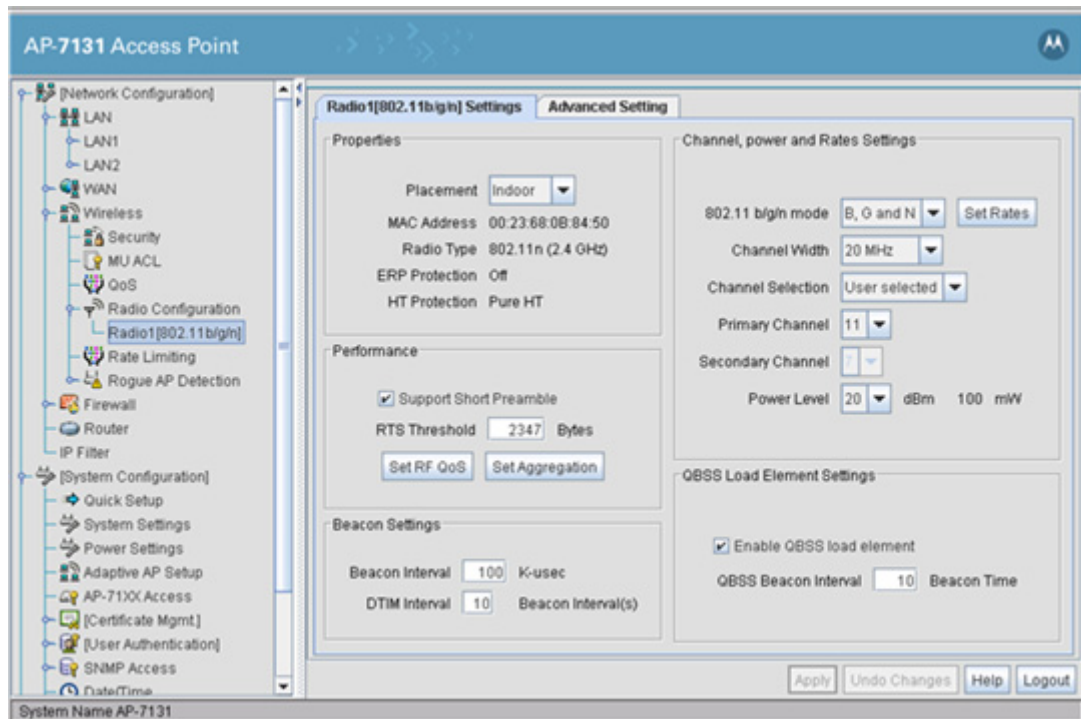

11. Refer to the **Channel, power and Rate Settings** field.

12. Set an 802.11 a/n or 802.11 b/g/n radio mode as appropriate.

For radio1, specify **B, G and N**, **B and G**, **G Only**, **B Only** or **N Only** to define whether the 802.11b/g/n radio transmits in the 2.4 GHz band exclusively for 802.11b (legacy) clients or transmits in the 2.4 GHz band for 802.11g/n clients. Selecting **B and G** enables the access point to transmit to both B and G clients if legacy clients (802.11b) partially comprise the network. Select accordingly based on the MU requirements of the network.



NOTE: Select the access point radio's 802.11 a/n or 802.11b/g/n mode carefully in respect to the radio's intended data rate and client support requirements, as the rates available differ depending on the selected mode. For more information on selected mode versus data rate, see *2.4 GHz Mode Versus Data Rate on page 12-8* or *5.2 GHz Mode Versus Data Rate on page 12-13*.

The rates for the access point's 2.4 GHz radio are:

- **B, G and N** Allows only basic rates (default setting)
- **B and G** Allows 11b basic rates. Does not allow MCS rates
- **G and N** Requires basic rates (either 6, 12, 24 or 1, 2, 5.5, 11, 6, 12, 24)
- **G Only** Requires one 11g basic rate. Does not allow MCS rates
- **B Only** Allows for 11b rates only. Does not allow G or N rates
- **N Only** Requires basic MCS rates

If the mode is **B and G**, the Channel Width option is not available, and a Secondary Channel cannot be defined.

For the 5.2 GHz radio, specify **A and N**, **A Only** or **N Only** to define whether the 802.11a/n radio transmits in the 5.2 GHz band exclusively for 802.11a clients, 802.11n clients or transmits in the 5.2 GHz band for both 802.11a/n clients.

The rates for the access point's 5.2 GHz radio are:

- *A Only* Allows 11a rates
- *N Only* Requires basic MCS rates
- *A and N* Allows only 11a basic rates (default setting)

13. For this example, leave the Channel Width at **20/40** and set the Channel to **User selected** for both the 802.11 b/g/n and 802.11 a/n radios.

20/40 MHz operation (the default setting for the 5 GHz radio) allows the access point to receive packets from clients using 20 MHz of bandwidth while transmitting a packet using 40 MHz bandwidth. This mode is supported for 11n users on both the 2.4 and 5 GHz radios. If an 11n user selects two channels (a Primary and Secondary channel), the system is configured for dynamic 20/40 operation. When 20/40 is selected, clients can take advantage of “wider channels.” 802.11n clients experience improved throughput using 40 MHz while legacy clients (either 802.11a or 802.11b/g depending on the radio selected) can still be serviced without interruption using 20 MHz.

User selected is the default Channel Selection setting. If 20/40 MHz is selected as the Channel Width (supporting 11n), the Secondary Channel drop down menu becomes enabled. The user must define the primary channel first. Then, depending on the primary channel defined, the secondary channel list is filled with channels making the combination of primary and secondary channels valid. The actual channels available depend on regulatory domain requirements.

14. Set the **Power Level** in respect to the antennas deployed and the defined channel.



NOTE: If you set the transmit power too high (in relation to FCC transmit requirements), the access point will display an Input Error message stating the maximum power level for the selected channel has been exceeded.

15. Select **Status and Statistics > Radio Stats > Radio1(802.11b/g/n) Statistics or Radio2 (802.11a/n) Statistics** from the access point menu tree.

Refer to the **Current Channel** parameter from within the Information field. This value displays (in red) the two channels utilized as a result of selecting 20/40 as the Channel Width. The first value represents the channel utilized for the 20 MHz bandwidth and the second value (displayed in parenthesis) is the channel supporting 40 MHz.

12.1.1 Supported Antennas by Band, Model, Rate and Transmit Power

Refer to the following Motorola Solutions AP7131 supported antennas for their US Regulatory Domain transmit power (in both the 2.4 and 5.2 GHz bands), rates and supported channels.

US Regulatory Domain 2.4 GHz Band

- *Yagi Antenna Models*
 - *Yagi Antenna Maximum Conducted Transmit Power Settings*
- *Panel Antenna Models*
 - *Panel Antenna Maximum Conducted Transmit Power Settings*
- *Embedded Antenna Models*
 - *Embedded Antenna Maximum Conducted Transmit Power Settings*
- *Dipole Antenna Models*
 - *Dipole Antenna Maximum Conducted Transmit Power Settings*
- *Patch Antenna Models*
 - *Patch Antenna Maximum Conducted Transmit Power Settings*

US Regulatory Domain 5.2 GHz Band

- *Yagi Antenna Models*
 - *Yagi Antenna Maximum Conducted Transmit Power Settings*
- *Panel Antenna Models*
 - *Panel Antenna Maximum Conducted Transmit Power Settings*
- *Embedded Antenna Models*
 - *Embedded Antenna Maximum Conducted Transmit Power Settings*
- *Dipole Antenna Models*
 - *Dipole Antenna Maximum Conducted Transmit Power Settings*
- *Patch Antenna Models*
 - *Patch Antenna Maximum Conducted Transmit Power Settings*

12.2 US Regulatory Domain 2.4 GHz Band

12.2.1 2.4 GHz Mode Versus Data Rate

When setting 2.4 GHz data rates using the access point's GUI applet, use the following chart to cross reference data rates to the radio's selected operational mode.

	<i>B, G and N</i>	<i>G and N</i>	<i>N Only</i>	<i>B and G</i>	<i>G Only</i>	<i>B Only</i>
LEGACY DSSS RATES (1, 2, 5.5, 11 MBPS)	X			X		X
LEGACY OFDM RATES (6,9,12,18,24,36,48,54 MBPS)	X	X		X	X	
802.11n HT20 RATES (MCS 0 MCS 15)	X	X	X			
802.11n HT40 RATES (MCS 0 MCS15)	X	X	X			

12.2.2 Yagi Antenna Models

The following is the Yagi antenna model for 2.4 GHz:

Motorola Solutions Part Number
ML-2499-BYGA2-01R

12.2.2.1 Yagi Antenna Maximum Conducted Transmit Power Settings

The following is a transmit power table (US domain) per Yagi antenna in the 2.4 GHz band:

20 MHZ CHANNEL	40 MHZ CHANNEL	LEGACY DSSS RATES (1, 2, 5.5, 11 MBPS)	LEGACY OFDM RATES (6,9,12,18,24,36, 48,54 MBPS)	802.11n HT20 RATES (MCS 0 MCS 15)	802.11n HT40 RATES (MCS 0 MCS15)
1		13	7	7	
2		13	7	7	
3	(1, 5)	13	7	7	2
4	(2, 6)	13	7	7	2
5	(3, 7)	13	7	7	2
6	(4, 8)	13	8	8	5
7	(5, 9)	12	7	6	2
8	(6, 10)	12	7	6	2
9	(7, 11)	12	7	6	2
10		12	7	6	
11		12	7	6	

With the most recent AP7131 series software release (4.0.0.0) the Web browser of the command line interface do not allow setting the transmit power to any value less than 4dBm.



NOTE: When a Yagi antenna is used, a 2dB external RF attenuator must be added. Lower power settings will be provided in subsequent software releases.

12.2.3 Panel Antenna Models

The following is the panel antenna model for 2.4 GHz:

Motorola Solutions Part Number
ML-2452-PTA3M3-036

12.2.3.1 Panel Antenna Maximum Conducted Transmit Power Settings

The following is a transmit power table (US domain) per panel antenna in the 2.4 GHz band:

20 MHZ CHANNEL	40 MHZ CHANNEL	LEGACY DSSS RATES (1, 2, 5.5, 11 MBPS)	LEGACY OFDM RATES (6,9,12,18,24,36, 48,54 MBPS)	802.11n HT20 RATES (MCS 0 MCS 15)	802.11n HT40 RATES (MCS 0 MCS15)
1		16	11	10	
2		16	11	10	
3	(1, 5)	16	11	10	7
4	(2, 6)	16	11	10	7
5	(3, 7)	16	11	10	7
6	(4, 8)	16	11	11	8
7	(5, 9)	16	11	9	5
8	(6, 10)	16	11	9	5
9	(7, 11)	16	11	9	5
10		16	11	9	
11		16	11	9	

12.2.4 Embedded Antenna Models

The following is the embedded antenna model for 2.4 GHz:

Motorola Solutions Part Number
ML-2452-PTA2M3X3-1

12.2.4.1 Embedded Antenna Maximum Conducted Transmit Power Settings

The following is a transmit power table (US domain) per embedded antenna in the 2.4 GHz band:

20 MHZ CHANNEL	40 MHZ CHANNEL	LEGACY DSSS RATES (1, 2, 5.5, 11 MBPS)	LEGACY OFDM RATES (6,9,12,18,24,36, 48,54 MBPS)	802.11n HT20 RATES (MCS 0 MCS 15)	802.11n HT40 RATES (MCS 0 MCS15)
1		20	16	16	
2		20	16	16	
3	(1, 5)	20	16	16	11
4	(2, 6)	20	16	16	11
5	(3, 7)	20	16	16	11
6	(4, 8)	18	14	14	12
7	(5, 9)	16	15	15	12
8	(6, 10)	16	15	15	12
9	(7, 11)	16	15	15	12
10		16	15	15	
11		16	15	15	

12.2.5 Dipole Antenna Models

The following are the dipole antenna models for 2.4 GHz:

Motorola Solutions Part Number	2.4 GHz Antenna Net Gain
ML-2452-APA2-01	3
ML-2499-HPA3-01R	4.7
ML-2452-APA6J-01 (microcell)	- 6

12.2.5.1 Dipole Antenna Maximum Conducted Transmit Power Settings

The following is a transmit power table (US domain) per dipole antenna in the 2.4 GHz band:



NOTE: The access point GUI only allows whole numbers be entered for transmit power. The decimal values are displayed within these tables to help installers accommodate for cable and accessory losses.

20 MHZ CHANNEL	40 MHZ CHANNEL	LEGACY DSSS RATES (1, 2, 5.5, 11 MBPS)	LEGACY OFDM RATES (6,9,12,18,24,36, 48,54 MBPS)	802.11n HT20 RATES (MCS 0 MCS 15)	802.11n HT40 RATES (MCS0 MCS15)
1		18.5	15.0	15.0	
2		18.5	15.0	15.0	
3	(1, 5)	18.5	16.0	16.5	10.0
4	(2, 6)	18.5	16.0	16.5	11.0
5	(3, 7)	18.5	16.0	16.0	12.0
6	(4, 8)	23.0	16.0	16.5	13.0
7	(5, 9)	19.0	16.0	16.5	12.0
8	(6, 10)	19.0	16.0	16.5	11.0
9	(7, 11)	19.0	15.0	16.5	9.0
10		19.0	14.0	16.0	
11		19.0	13.5	13.0	

12.2.6 Patch Antenna Models

The following is the patch antenna model for 2.4 GHz:

Motorola Solutions Part Number	2.4 GHz Antenna Net Gain
ML-2452-PTA3M3-036	3

12.2.6.1 Patch Antenna Maximum Conducted Transmit Power Settings

The following is a transmit power table (US domain) per patch antenna in the 2.4 GHz band:

20 MHZ CHANNEL	40 MHZ CHANNEL	LEGACY DSSS RATES (1, 2, 5.5, 11 MBPS)	LEGACY OFDM RATES (6,9,12,18,24,36, 48,54 MBPS)	802.11n HT20 RATES (MCS 0 MCS 15)	802.11n HT40 RATES (MCS0 MCS15)
1		16	15	12	
2		16	15	12	
3	(1, 5)	16	15	12	9
4	(2, 6)	16	15	12	9
5	(3, 7)	16	15	12	9
6	(4, 8)	20	15	15	12
7	(5, 9)	18	13	12	10
8	(6, 10)	18	13	12	10
9	(7, 11)	18	13	12	10
10		18	13	12	
11		18	13	12	

12.3 US Regulatory Domain 5.2 GHz Band

12.3.1 5.2 GHz Mode Versus Data Rate

When setting 5.2 GHz data rates using the access point's GUI applet, use the following chart to cross reference data rates to the radio's selected operational mode.

	<i>A and N</i>	<i>N Only</i>	<i>A Only</i>
LEGACY OFDM RATES (6,9,12,18,24,36,48,54 MBPS)	X		X
802.11n HT20 RATES (MCS 0 MCS 15)	X	X	
802.11n HT40 RATES (MCS 0 MCS 15)	X	X	

12.3.2 Yagi Antenna Models

The following is the Yagi antenna model for 5.2 GHz:

Motorola Solutions Part Number
ML-5299-BYGA15-012

12.3.2.1 Yagi Antenna Maximum Conducted Transmit Power Settings

The following is a transmit power table (US domain) per Yagi antenna in the 5 GHz band:

20 MHZ CHANNEL	40 MHZ CHANNEL	LEGACY OFDM RATES (6,9,12,18,24,36,48,54 MBPS)	802.11n HT20 RATES (MCS 0 MCS 15)	802.11n HT40 RATES (MCS 0 MCS 15)
36		2	2.5	
38	(36, 40)			4
40		2	2.5	
42		2.5	2.5	
44		2.5	2.5	
46	(44, 48)			4
48		2.5	4	
52		9	9	
54	(52, 56)			11
56		9	9	
60		8.5	9	
62	(60, 64)			10
64		8.5	9	
100		8	8.5	

20 MHZ CHANNEL	40 MHZ CHANNEL	LEGACY OFDM RATES (6,9,12,18,24,36,48,54 MBPS)	802.11n HT20 RATES (MCS 0 MCS 15)	802.11n HT40 RATES (MCS 0 MCS 15)
102	(100, 104)			5
104		8	8.5	
108		8	8.5	
112		8	8.5	
110	(108, 112)			11
116		8	8.5	
118	(116, 120)			10
120		8	8.5	
124		7.5	7.5	
126	(124, 128)			10
128		7.5	7.5	
132		7.5	7.5	
134	(132, 136)			10
136		7.5	7.5	
140		7.5	7.5	
149		7.0	7.5	
151	(149, 153)			4.5
153		7.0	7.5	
157		7.5	8.0	
159	(157, 161)			5.0
161		8.0	9.0	
165		8.0	9.0	

12.3.3 Panel Antenna Models

The following are the panel antenna models for 5.2 GHz:

Motorola Solutions Part Number
ML-5299-WPNA1-01R
ML-2452-PNL9M3-036

12.3.3.1 Panel Antenna Maximum Conducted Transmit Power Settings

The following is a transmit power table (US domain) per panel antenna in the 5 GHz band:

20 MHZ CHANNEL	40 MHZ CHANNEL	LEGACY OFDM RATES (6,9,12,18,24,36,48,54 MBPS)	802.11n HT20 RATES (MCS 0 MCS 15)	802.11n HT40 RATES (MCS 0 MCS 15)
36		4	4	
38	(36, 40)			6
40		4	4	
42		4	4	
44		4	4	
46	(44, 48)			6
48		4	4	
52		10	10	
54	(52, 56)			13
56		10	10	
60		10	10	
62	(60, 64)			11
64		10	10	
100		10	10	
102	(100, 104)			5
104		10	10	
108		10	10	
112		10	10	
110	(108, 112)			13
116		10	10	
118	(116, 120)			13
120		10	10	
124		10	10	
126	(124, 128)			12

20 MHZ CHANNEL	40 MHZ CHANNEL	LEGACY OFDM RATES (6,9,12,18,24,36,48,54 MBPS)	802.11n HT20 RATES (MCS 0 MCS 15)	802.11n HT40 RATES (MCS 0 MCS 15)
128		10	10	
132		10	10	
134	(132, 136)			12
136		10	10	
140		8	8	
149		8.0	9.0	
151	(149, 153)			6.0
153		8.0	9.0	
157		9.0	10.0	
159	(157, 161)			7.0
161		10	10	
165		10	10	

12.3.4 Embedded Antenna Models

The following is the embedded antenna model for 5.2 GHz:

Motorola Solutions Part Number
ML-2452-PTA2M3X3-1

12.3.4.1 Embedded Antenna Maximum Conducted Transmit Power Settings

The following is a transmit power table (US domain) per embedded antenna in the 5 GHz band:

20 MHZ CHANNEL	40 MHZ CHANNEL	LEGACY OFDM RATES (6,9,12,18,24,36,48,54 MBPS)	802.11n HT20 RATES (MCS 0 MCS 15)	802.11n HT40 RATES (MCS 0 MCS 15)
36		11	11	
38	(36, 40)			12
40		11	11	
42		11	11	
44		11	11	
46	(44, 48)			13
48		11	11	
52		18	18	
54	(52, 56)			20
56		18	18	
60		18	18	
62	(60, 64)			14
64		18	18	
100		15	16	
102	(100, 104)			8
104		14	16	
108		14	16	
112		14	16	
110	(108, 112)			19
116		14	16	
118	(116, 120)			19
120		18	18	
124		18	13	
126	(124, 128)			19
128		14	13	

20 MHZ CHANNEL	40 MHZ CHANNEL	LEGACY OFDM RATES (6,9,12,18,24,36,48,54 MBPS)	802.11n HT20 RATES (MCS 0 MCS 15)	802.11n HT40 RATES (MCS 0 MCS 15)
132		14	13	
134	(132, 136)			14
136		13	13	
140		13	13	
149		18.0	18.0	
151	(149, 153)			15.0
153		18.0	18.0	
157		18.0	18.0	
159	(157, 161)			16.0
161		19.0	19.0	
165		19.0	19.0	

12.3.5 Dipole Antenna Models

The following are the dipole antenna models for 5.2 GHz:

Motorola Solutions Part Number
ML-5299HPA1-01R
ML-2452-APA6J-01
ML-2452-APA2-01

12.3.5.1 Dipole Antenna Maximum Conducted Transmit Power Settings

The following is a transmit power table (US domain) per dipole antenna in the 5 GHz band:

20 MHZ CHANNEL	40 MHZ CHANNEL	LEGACY OFDM RATES (6,9,12,18,24,36,48,54 MBPS)	802.11n HT20 RATES (MCS 0 MCS 15)	802.11n HT40 RATES (MCS 0 MCS 15)
36		11	11	
38	(36, 40)			12
40		11	11	
42		11	11	
44		11	11	
46	(44, 48)			13
48		11	11	
52		18	18	
54	(52, 56)			20
56		18	18	
60		18	18	
62	(60, 64)			14
64		18	18	
100		15	14	
102	(100, 104)			7
104		15	14	
108		15	14	
112		15	14	
110	(108, 112)			19
116		15	14	
118	(116, 120)			19
120		18	18	
124		15	18	

20 MHZ CHANNEL	40 MHZ CHANNEL	LEGACY OFDM RATES (6,9,12,18,24,36,48,54 MBPS)	802.11n HT20 RATES (MCS 0 MCS 15)	802.11n HT40 RATES (MCS 0 MCS 15)
126	(124, 128)			19
128		15	18	
132		15	18	
134	(132, 136)			14
136		13	16	
140		13	16	
149		18.0	18.0	
151	(149, 153)			15.0
153		18.0	19.0	
157		18.0	19.0	
159	(157, 161)			16.0
161		19.0	19.0	
165		19.0	19.0	

12.3.6 Patch Antenna Models

The following is the patch antenna model for 5.2 GHz:

Motorola Solutions Part Number
ML-2452-PTA3M3-036

12.3.6.1 Patch Antenna Maximum Conducted Transmit Power Settings

The following is a transmit power table (US domain) per patch antenna in the 5 GHz band:

20 MHZ CHANNEL	40 MHZ CHANNEL	LEGACY OFDM RATES (6,9,12,18,24,36,48,54 MBPS)	802.11n HT20 RATES (MCS 0 MCS 15)	802.11n HT40 RATES (MCS 0 MCS 15)
36		11	11	
38	(36, 40)			12
40		11	11	
42		11	11	
44		11	11	
46	(44, 48)			13
48		11	11	
52		18	18	
54	(52, 56)			20
56		18	18	
60		18	18	
62	(60, 64)			14
64		18	18	
100		15	16	
102	(100, 104)			8
104		18	16	
108		18	16	
112		18	18	
110	(108, 112)			13
116		18	18	
118	(116, 120)			19
120		18	18	
124		18	18	
126	(124, 128)			19
128		18	18	

20 MHZ CHANNEL	40 MHZ CHANNEL	LEGACY OFDM RATES (6,9,12,18,24,36,48,54 MBPS)	802.11n HT20 RATES (MCS 0 MCS 15)	802.11n HT40 RATES (MCS 0 MCS 15)
132		18	18	
134	(132, 136)			14
136		13	13	
140		13	13	
149		18.0	18.0	
151	(149, 153)			15.0
153		18.0	19.0	
157		18.0	19.0	
159	(157, 161)			16.0
161		19.0	19.0	
165		19.0	19.0	

12.4 Japanese TELEC Regulatory Domain 2.4 GHz Band

12.4.1 Panel Antenna Model

The following is the panel antenna model for 2.4 GHz:

Motorola Solutions Part Number
ML-2499-11PNA2-01R

12.4.1.1 Panel Antenna Maximum Conducted Transmit Power Settings

The following is a transmit power table (Japanese domain) per panel antenna in the 2.4 GHz band:

20 MHZ CHANNEL	40 MHZ CHANNEL	LEGACY DSSS RATES (1, 2, 5.5, 11 MBPS)	LEGACY OFDM RATES (6,9,12,18,24,36, 48,54 MBPS)	802.11n HT20 RATES (MCS 0 MCS 15)	802.11n HT40 RATES (MCS 0 MCS15)
1		19.0	19.0	19.0	
2		19.0	19.0	19.0	
3	(1, 5)	19.0	19.0	19.0	16.0
4	(2, 6)	19.0	19.0	19.0	16.0
5	(3, 7)	19.0	19.0	19.0	16.0
6	(4, 8)	19.0	19.0	19.0	16.0
7	(5, 9)	19.0	19.0	19.0	16.0
8	(6, 10)	19.0	19.0	19.0	16.0
9	(7, 11)	19.0	19.0	19.0	16.0
10		19.0	19.0	19.0	
11		19.0	19.0	19.0	
12		19.0	19.0	19.0	
13		19.0	19.0	19.0	
14		19.0			

12.4.2 Embedded Antenna Model

The following is the embedded antenna model for 2.4 GHz:

Motorola Solutions Part Number
ML-2452-PTA2M3X3-1

12.4.2.1 Panel Antenna Maximum Conducted Transmit Power Settings

The following is a transmit power table (Japanese domain) per embedded antenna in the 2.4 GHz band:

20 MHZ CHANNEL	40 MHZ CHANNEL	LEGACY DSSS RATES (1, 2, 5.5, 11 MBPS)	LEGACY OFDM RATES (6,9,12,18,24,36, 48,54 MBPS)	802.11n HT20 RATES (MCS 0 MCS 15)	802.11n HT40 RATES (MCS 0 MCS15)
1		11.0	11.0	11.0	
2		11.0	11.0	11.0	
3	(1, 5)	11.0	11.0	11.0	8.0
4	(2, 6)	11.0	11.0	11.0	8.0
5	(3, 7)	11.0	11.0	11.0	8.0
6	(4, 8)	11.0	11.0	11.0	8.0
7	(5, 9)	11.0	11.0	11.0	8.0
8	(6, 10)	11.0	11.0	11.0	8.0
9	(7, 11)	11.0	11.0	11.0	8.0
10		11.0	11.0	11.0	
11		11.0	11.0	11.0	
12		11.0	11.0	11.0	
13		11.0	11.0	11.0	
14		11.0			

12.4.3 Dipole Antenna Model

The following is the patch antenna model for 2.4 GHz:

Motorola Solutions Part Number
ML-2452-APA2-01
ML-2499-HPA3-01R
ML-2452-APA6J-01 (microcell)

12.4.3.1 Dipole Antenna Maximum Conducted Transmit Power Settings

The following is a transmit power table (Japanese domain) per dipole antenna in the 2.4 GHz band:

20 MHZ CHANNEL	40 MHZ CHANNEL	LEGACY DSSS RATES (1, 2, 5.5, 11 MBPS)	LEGACY OFDM RATES (6,9,12,18,24,36, 48,54 MBPS)	802.11n HT20 RATES (MCS 0 MCS 15)	802.11n HT40 RATES (MCS 0 MCS15)
1		14.0	14.0	14.0	
2		14.0	14.0	14.0	
3	(1, 5)	14.0	14.0	14.0	11
4	(2, 6)	14.0	14.0	14.0	11
5	(3, 7)	14.0	14.0	14.0	11
6	(4, 8)	14.0	14.0	14.0	11
7	(5, 9)	14.0	14.0	14.0	11
8	(6, 10)	14.0	14.0	14.0	11
9	(7, 11)	14.0	14.0	14.0	11
10		14.0	14.0	14.0	
11		14.0	14.0	14.0	
12		14.0	14.0	14.0	
13		14.0	14.0	14.0	
14		14.0			

12.4.4 Patch Antenna Model

The following is the patch antenna model for 2.4 GHz:

Motorola Solutions Part Number	2.4 GHz Antenna Net Gain
ML-2452-PTA3M3-036	3

12.4.4.1 Patch Antenna Maximum Conducted Transmit Power Settings

The following is a transmit power table (Japanese domain) per patch antenna in the 2.4 GHz band:

20 MHZ CHANNEL	40 MHZ CHANNEL	LEGACY DSSS RATES (1, 2, 5.5, 11 MBPS)	LEGACY OFDM RATES (6,9,12,18,24,36, 48,54 MBPS)	802.11n HT20 RATES (MCS 0 MCS 15)	802.11n HT40 RATES (MCS0 MCS15)
1		16.0	16.0	16.0	
2		16.0	16.0	16.0	
3	(1, 5)	16.0	16.0	16.0	10.0
4	(2, 6)	16.0	16.0	16.0	10.0
5	(3, 7)	16.0	16.0	16.0	10.0
6	(4, 8)	16.0	16.0	16.0	10.0
7	(5, 9)	16.0	16.0	16.0	10.0
8	(6, 10)	16.0	16.0	16.0	10.0
9	(7, 11)	16.0	16.0	16.0	10.0
10		16.0	16.0	16.0	
11		16.0	16.0	16.0	
12		16.0	16.0	16.0	
13		16.0	16.0	16.0	
14		16.0			

12.5 Japan TELEC Regulatory Domain 5.2 GHz Band

12.5.1 Panel Antenna Models

The following are the panel antenna models for 5.2 GHz:

Motorola Solutions Part Number
ML-5299-WPNA1-01R
ML-2452-PNL9M3-036

12.5.1.1 Panel Antenna Maximum Conducted Transmit Power Settings

The following is a transmit power table (Japanese domain) per panel antenna in the 5 GHz band:

20 MHZ CHANNEL	40 MHZ CHANNEL	LEGACY OFDM RATES (6,9,12,18,24,36,48,54 MBPS)	802.11n HT20 RATES (MCS 0 MCS 15)	802.11n HT40 RATES (MCS 0 MCS 15)
36		12.0	12.0	
38	(36, 40)			18.0
40		12.0	12.0	
42		12.0	12.0	
44		12.0	12.0	
46	(44, 48)			18.0
48		12.0	12.0	
52		12.0	12.0	
54	(52, 56)			18.0
56		12.0	12.0	
60		12.0	12.0	
62	(60, 64)			18.0
64		12.0	12.0	
100		19.0	19.0	
102	(100, 104)			18.0
104		19.0	19.0	
108		19.0	19.0	
112		19.0	19.0	
110	(108, 112)			18.0
116		19.0	19.0	
118	(116, 120)			18.0
120		19.0	19.0	
124		19.0	19.0	

20 MHZ CHANNEL	40 MHZ CHANNEL	LEGACY OFDM RATES (6,9,12,18,24,36,48,54 MBPS)	802.11n HT20 RATES (MCS 0 MCS 15)	802.11n HT40 RATES (MCS 0 MCS 15)
126	(124, 128)			18.0
128		19.0	19.0	
132		19.0	19.0	
134	(132, 136)			18.0
136		19.0	19.0	
140		19.0	19.0	
149				
151	(149, 153)			
153				
157				
159	(157, 161)			
161				
165				

12.5.2 Embedded Antenna Model

The following is the embedded antenna model for 5.2 GHz:

Motorola Solutions Part Number
ML-5299-WPNA1-01R

12.5.2.1 Embedded Antenna Maximum Conducted Transmit Power Settings

The following is a transmit power table (Japanese domain) per embedded antenna in the 5 GHz band:

20 MHZ CHANNEL	40 MHZ CHANNEL	LEGACY OFDM RATES (6,9,12,18,24,36,48,54 MBPS)	802.11n HT20 RATES (MCS 0 MCS 15)	802.11n HT40 RATES (MCS 0 MCS 15)
36		10.0	10.0	
38	(36, 40)			7.0
40		10.0	10.0	
42		10.0	10.0	
44		10.0	10.0	
46	(44, 48)			7.0
48		10.0	10.0	
52		10.0	10.0	
54	(52, 56)			7.0
56		10.0	10.0	
60		10.0	10.0	
62	(60, 64)			7.0
64		10.0	10.0	
100		17.0	17.0	
102	(100, 104)			7.0
104		17.0	17.0	
108		17.0	17.0	
112		17.0	17.0	
110	(108, 112)			7.0
116		17.0	17.0	
118	(116, 120)			7.0
120		17.0	17.0	
124		17.0	17.0	
126	(124, 128)			7.0
128		17.0	17.0	

20 MHZ CHANNEL	40 MHZ CHANNEL	LEGACY OFDM RATES (6,9,12,18,24,36,48,54 MBPS)	802.11n HT20 RATES (MCS 0 MCS 15)	802.11n HT40 RATES (MCS 0 MCS 15)
132		17.0	17.0	
134	(132, 136)			7.0
136		17.0	17.0	
140		17.0	17.0	
149				
151	(149, 153)			
153				
157				
159	(157, 161)			
161				
165				

12.5.3 Dipole Antenna Models

The following are the dipole antenna models for 5.2 GHz:

Motorola Solutions Part Number
ML-5299-HPA1-01R
ML-2452-APA6J-01
ML-2452-APA2-01

12.5.3.1 Dipole Antenna Maximum Conducted Transmit Power Settings

The following is a transmit power table (Japanese domain) per dipole antenna in the 5 GHz band:

20 MHZ CHANNEL	40 MHZ CHANNEL	LEGACY OFDM RATES (6,9,12,18,24,36,48,54 MBPS)	802.11n HT20 RATES (MCS 0 MCS 15)	802.11n HT40 RATES (MCS 0 MCS 15)
36		12.0	12.0	
38	(36, 40)			9.0
40		12.0	12.0	
42		12.0	12.0	
44		12.0	12.0	
46	(44, 48)			9.0
48		12.0	12.0	
52		12.0	12.0	
54	(52, 56)			9.0
56		12.0	12.0	
60		12.0	12.0	
62	(60, 64)			9.0
64		12.0	12.0	
100		19.0	19.0	
102	(100, 104)			9.0
104		19.0	19.0	
108		19.0	19.0	
112		19.0	19.0	
110	(108, 112)			9.0
116		19.0	19.0	
118	(116, 120)			9.0
120		19.0	19.0	
124		19.0	19.0	
126	(124, 128)			9.0

20 MHZ CHANNEL	40 MHZ CHANNEL	LEGACY OFDM RATES (6,9,12,18,24,36,48,54 MBPS)	802.11n HT20 RATES (MCS 0 MCS 15)	802.11n HT40 RATES (MCS 0 MCS 15)
128		19.0	19.0	
132		19.0	19.0	
134	(132, 136)			9.0
136		19.0	19.0	
140		19.0	19.0	
149				
151	(149, 153)			
153				
157				
159	(157, 161)			
161				
165				

12.5.4 Patch Antenna Model

The following is the patch antenna model for 5.2 GHz:

Motorola Solutions Part Number
ML-2452-PTA3M3-036

12.5.4.1 Patch Antenna Maximum Conducted Transmit Power Settings

The following is a transmit power table (Japanese domain) per patch antenna in the 5 GHz band:

20 MHZ CHANNEL	40 MHZ CHANNEL	LEGACY OFDM RATES (6,9,12,18,24,36,48,54 MBPS)	802.11n HT20 RATES (MCS 0 MCS 15)	802.11n HT40 RATES (MCS 0 MCS 15)
36		21.0	21.0	
38	(36, 40)			10.0
40		21.0	21.0	
42		21.0	21.0	
44		21.0	21.0	
46	(44, 48)			10.0
48		21.0	21.0	
52		21.0	21.0	
54	(52, 56)			10.0
56		21.0	21.0	
60		21.0	21.0	
62	(60, 64)			10.0
64		21.0	21.0	
100		20.0	20.0	
102	(100, 104)			17.0
104		20.0	20.0	
108		20.0	20.0	
112		20.0	20.0	
110	(108, 112)			17.0
116		20.0	20.0	
118	(116, 120)			17.0
120		20.0	20.0	
124		20.0	20.0	
126	(124, 128)			17.0
128		20.0	20.0	

20 MHZ CHANNEL	40 MHZ CHANNEL	LEGACY OFDM RATES (6,9,12,18,24,36,48,54 MBPS)	802.11n HT20 RATES (MCS 0 MCS 15)	802.11n HT40 RATES (MCS 0 MCS 15)
132		20.0	20.0	
134	(132, 136)			17.0
136		20.0	20.0	
140		20.0	20.0	
149				
151	(149, 153)			
153				
157				
159	(157, 161)			
161				
165				

AP650 Regulatory Domains

13.1 US Regulatory Domain 2.4 GHz Band

13.1.1 Dipole Antenna Model

The following is the dipole antenna model for 2.4 GHz:

<i>Motorola Solutions Part Number</i>
ML-2452-APA2-01

13.1.1.1 Dipole Antenna Maximum Conducted Transmit Power Settings

The following is a transmit power table (US domain) per dipole antenna in the 2.4 GHz band:

20 MHZ CHANNEL	40 MHZ CHANNEL	LEGACY DSSS RATES (1, 2, 5.5, 11 MBPS)	LEGACY OFDM RATES (6,9,12,18,24,36, 48,54 MBPS)	802.11n HT20 RATES (MCS 0 MCS 15)	802.11n HT40 RATES (MCS 0 MCS15)
1		19.5	17.0	16.0	
2		19.5	17.0	16.0	
3	(1, 5)	21.0	21.0	20.0	14.5
4	(2, 6)	21.0	21.0	21.0	14.5
5	(3, 7)	21.0	21.0	20.0	14.5
6	(4, 8)	21.0	21.0	20.0	16.5
7	(5, 9)	21.0	21.0	20.0	13.0
8	(6, 10)	21.0	21.0	20.0	13.0
9	(7, 11)	20.0	16.5	16.5	13.0
10	(8, 12)	20.0	16.5	16.5	
11	(9, 13)	20.0	16.5	16.5	

13.1.2 Internal AP650 Dual Band Antenna Models

The following is the internal dual band antenna model for 2.4 GHz:

Motorola Solutions Part Number
57RPAA13.G66
57RPAA13.G67
57RPAA13.G68
57RPAA13.G69
57RPAA13.G6A
57RPAA13.G6B

13.1.2.1 AP650 Internal Dual Band Antenna Maximum Conducted Transmit Power Settings

The following is a transmit power table (US domain) per internal dual band antenna in the 2.4 GHz band:

20 MHZ CHANNEL	40 MHZ CHANNEL	LEGACY DSSS RATES (1, 2, 5.5, 11 MBPS)	LEGACY OFDM RATES (6,9,12,18,24,36, 48,54 MBPS)	802.11n HT20 RATES (MCS 0 MCS 15)	802.11n HT40 RATES (MCS 0 MCS15)
1		19.0	16.0	15.0	
2		19.0	16.0	15.0	
3	(1, 5)	21.0	16.0	15.0	12.5
4	(2, 6)	21.0	21.0	20.0	12.5
5	(3, 7)	21.0	21.0	20.0	12.5
6	(4, 8)	21.0	21.0	20.0	15.5
7	(5, 9)	21.0	21.0	20.0	11.5
8	(6, 10)	21.0	21.0	20.0	11.5
9	(7, 11)	21.0	16.0	15.0	11.5
10	(8, 12)	18.5	16.0	15.0	
11	(9, 13)	18.5	16.0	15.0	

13.1.3 Indoor Patch Antenna Model

The following is the indoor patch antenna model for 2.4 GHz:

Motorola Solutions Part Number
ML-2499- SD3-01R

13.1.3.1 Indoor Patch Antenna Maximum Conducted Transmit Power Settings

The following is a transmit power table (US domain) per Indoor Patch antenna in the 2.4 GHz band:

20 MHZ CHANNEL	40 MHZ CHANNEL	LEGACY DSSS RATES (1, 2, 5.5, 11 MBPS)	LEGACY OFDM RATES (6,9,12,18,24,36, 48,54 MBPS)	802.11n HT20 RATES (MCS 0 MCS 15)	802.11n HT40 RATES (MCS 0 MCS15)
1		17.5	15.0	13.0	
2		17.5	15.0	13.0	
3	(1, 5)	17.5	15.0	13.0	10.0
4	(2, 6)	20.5	19.0	19.0	10.0
5	(3, 7)	20.5	19.0	19.0	10.0
6	(4, 8)	20.5	19.0	19.0	13.5
7	(5, 9)	20.5	19.0	19.0	10.0
8	(6, 10)	20.5	19.0	19.0	10.0
9	(7, 11)	19.0	13.5	13.5	10.0
10	(8, 12)	19.0	13.5	13.5	
11	(9, 13)	19.0	13.5	13.5	

13.1.4 Outdoor Omni Antenna Model

The following is the Outdoor Omni antenna model for 2.4 GHz:

Motorola Solutions Part Number
ML-2499-HPA3-01R

13.1.4.1 Outdoor Omni Antenna Maximum Conducted Transmit Power Settings

The following is a transmit power table (US domain) per outdoor omni antenna in the 2.4 GHz band:

20 MHZ CHANNEL	40 MHZ CHANNEL	LEGACY DSSS RATES (1, 2, 5.5, 11 MBPS)	LEGACY OFDM RATES (6,9,12,18,24,36, 48,54 MBPS)	802.11n HT20 RATES (MCS 0 MCS 15)	802.11n HT40 RATES (MCS0 MCS15)
1		19.0	13.5	14.0	
2		19.0	13.5	14.0	
3	(1, 5)	19.0	13.5	14.0	10.5
4	(2, 6)	21.0	19.0	19.0	10.5
5	(3, 7)	21.0	19.0	19.0	10.5
6	(4, 8)	21.0	19.0	19.0	14.0
7	(5, 9)	21.0	19.0	19.0	9.5
8	(6, 10)	21.0	19.0	19.0	9.5
9	(7, 11)	19.5	14.0	13.0	9.5
10	(8, 12)	19.5	14.0	13.0	
11	(9, 13)	19.5	14.0	13.0	

13.1.5 Panel Antenna Models

The following is the panel antenna model for 2.4 GHz:

Motorola Solutions Part Number
ML-2452-PNA5-01R

13.1.5.1 Panel Antenna Maximum Conducted Transmit Power Settings

The following is a transmit power table (US domain) per panel antenna in the 2.4 GHz band:

20 MHZ CHANNEL	40 MHZ CHANNEL	LEGACY DSSS RATES (1, 2, 5.5, 11 MBPS)	LEGACY OFDM RATES (6,9,12,18,24,36, 48,54 MBPS)	802.11n HT20 RATES (MCS 0 MCS 15)	802.11n HT40 RATES (MCS0 MCS15)
1		16.5	13.0	12.5	
2		16.5	13.0	12.5	
3	(1, 5)	16.5	13.0	12.5	10.0
4	(2, 6)	20.0	17.0	18.0	10.0
5	(3, 7)	20.0	17.0	18.0	10.0
6	(4, 8)	20.0	17.0	18.0	13.0
7	(5, 9)	20.0	17.0	18.0	9.0
8	(6, 10)	20.0	17.0	18.0	9.0
9	(7, 11)	17.0	13.0	12.0	9.0
10	(8, 12)	17.0	13.0	12.0	
11	(9, 13)	17.0	13.0	12.0	

13.2 US Regulatory Domain 5 GHz Band

13.2.1 Dual Band Dipole Antenna Model

The following is the dual band dipole antenna model for 5 GHz:

Motorola Solutions Part Number
ML-2452-APA2-01

13.2.1.1 Dual Band Dipole Antenna Maximum Conducted Transmit Power Settings

The following is a transmit power table (US domain) per dual band dipole antenna in the 5 GHz band:

20 MHZ CHANNEL	40 MHZ CHANNEL	LEGACY OFDM RATES (6,9,12,18,24,36,48,54 MBPS)	802.11n HT20 RATES (MCS 0 MCS 15)	802.11n HT40 RATES (MCS 0 MCS 15)
36		11.0	11.0	
38	(36, 40)	11.0	11.0	11.0
40		11.0	11.0	
42		11.0	11.0	
44		11.0	11.0	
46	(44, 48)	11.0	11.0	11.0
48		11.0	11.0	
52		17.0	17.0	
54	(52, 56)	17.0	17.0	16.5
56		17.0	17.0	
60		17.0	17.0	
62	(60, 64)	17.0	17.0	11.0
64		15.0	15.0	
100		12.0	15.0	
102	(100, 104)	17.0	17.0	10.0
104		17.0	17.0	
108		17.0	17.0	
112		17.0	17.0	
110	(108, 112)	17.0	17.0	17.5
116		17.0	17.0	
118	(116, 120)	17.0	17.0	14.0
120		17.0	17.0	
124		17.0	17.0	

20 MHZ CHANNEL	40 MHZ CHANNEL	LEGACY OFDM RATES (6,9,12,18,24,36,48,54 MBPS)	802.11n HT20 RATES (MCS 0 MCS 15)	802.11n HT40 RATES (MCS 0 MCS 15)
126	(124, 128)	17.0	17.0	17.5
128		17.0	17.0	
132		17.0	17.0	
134	(132, 136)	17.0	17.0	14.0
136		17.0	17.0	
140		12.0	12.0	
149		19.0	19.0	
151	(149, 153)	19.0	19.0	18.0
153		19.0	19.0	
157		19.0	19.0	
159	(157, 161)	19.0	19.0	18.0
161		19.0	19.0	
165		19.0	19.0	

13.2.2 Internal Dual Band Antenna Models

The following are the internal dual band antenna models for 5.2 GHz:

Motorola Solutions Part Number
57RPAA13.G66
57RPAA13.G67
57RPAA13.G68
57RPAA13.G69
57RPAA13.G6A
57RPAA13.G6B

13.2.2.1 Internal Dual Band Antenna Maximum Conducted Transmit Power Settings

The following is a transmit power table (US domain) per internal dual band antenna in the 5 GHz band:

20 MHZ CHANNEL	40 MHZ CHANNEL	LEGACY OFDM RATES (6,9,12,18,24,36,48,54 MBPS)	802.11n HT20 RATES (MCS 0 MCS 15)	802.11n HT40 RATES (MCS 0 MCS 15)
36		11.0	11.0	
38	(36,40)	11.0	11.0	11.0
40		11.0	11.0	
42		11.0	11.0	
44		11.0	11.0	
46	(44,48)	11.0	11.0	12.5
48		11.0	11.0	
52		17.5	17.5	
54	(52,56)	17.5	17.5	18.0
56		17.5	17.5	
60		17.5	17.5	
62	(60,64)	17.5	17.5	14.0
64		14.5	14.5	
100		17.0	17.0	
102	(100,104)	17.0	17.0	15.0
104		17.0	17.0	
108		17.0	17.0	
112		17.0	17.0	
110	(108,112)	17.0	17.0	18.0
116		17.0	17.0	
118	(116,120)	17.0	17.0	18.0
120		17.0	17.0	
124		17.0	17.0	

20 MHZ CHANNEL	40 MHZ CHANNEL	LEGACY OFDM RATES (6,9,12,18,24,36,48,54 MBPS)	802.11n HT20 RATES (MCS 0 MCS 15)	802.11n HT40 RATES (MCS 0 MCS 15)
126	(124,128)	17.0	17.0	18.0
128		17.0	17.0	
132		17.0	17.0	
134	(132,136)	17.0	17.0	17.5
136		17.0	17.0	
140		15.5	15.5	
149		19.0	19.0	
151	(149,153)	19.0	19.0	18.0
153		19.0	19.0	
157		19.0	19.0	
159	(157,161)	19.0	19.0	18.0
161		19.0	19.0	
165		19.0	19.0	

13.2.3 Indoor Patch Model

The following is the indoor patch antenna model for 5.2 GHz:

Motorola Solutions Part Number
ML-5299-PTA1-01R

13.2.3.1 Indoor Patch Antenna Maximum Conducted Transmit Power Settings

The following is a transmit power table (US domain) per indoor patch antenna in the 5 GHz band:

20 MHZ CHANNEL	40 MHZ CHANNEL	LEGACY OFDM RATES (6,9,12,18,24,36,48,54 MBPS)	802.11n HT20 RATES (MCS 0 MCS 15)	802.11n HT40 RATES (MCS 0 MCS 15)
36		9.5	9.5	
38	(36, 40)	10.0	10.0	10.0
40		10.0	10.0	
42		10.0	10.0	
44		10.0	10.0	
46	(44, 48)	10.0	10.0	11.0
48		10.0	10.5	
52		17.5	17.5	
54	(52, 56)	17.5	17.5	17.0
56		17.5	17.5	
60		17.5	17.5	
62	(60, 64)	17.5	17.5	10.5
64		15.0	15.0	
100		12.5	12.5	
102	(100, 104)	17.0	17.5	8.0
104		17.0	17.5	
108		17.0	17.5	
112		17.0	17.5	
110	(108, 112)	17.0	17.5	16.0
116		17.0	17.5	
118	(116, 120)	17.0	17.5	16.0
120		17.0	17.5	
124		17.0	17.5	
126	(124, 128)	17.0	17.5	16.0
128		17.0	17.5	

20 MHZ CHANNEL	40 MHZ CHANNEL	LEGACY OFDM RATES (6,9,12,18,24,36,48,54 MBPS)	802.11n HT20 RATES (MCS 0 MCS 15)	802.11n HT40 RATES (MCS 0 MCS 15)
132		17.0	17.5	
134	(132, 136)	17.0	17.5	13.0
136		17.0	17.5	
140		14.0	14.0	
149		19.0	19.0	
151	(149, 153)	19.0	19.0	18.0
153		19.0	19.0	
157		19.0	19.0	
159	(157, 161)	19.0	19.0	18.0
161		19.0	19.0	
165		19.0	19.0	

13.2.4 Outdoor Omni Antenna Model

The following is the outdoor omni antenna models for 5.2 GHz:

Motorola Solutions Part Number
ML-5299-HPA1-01R

13.2.4.1 Outdoor Omni Antenna Transmit Power Settings

The following is a transmit power table (US domain) per outdoor omni antenna in the 5 GHz band:

20 MHZ CHANNEL	40 MHZ CHANNEL	LEGACY OFDM RATES (6,9,12,18,24,36,48,54 MBPS)	802.11n HT20 RATES (MCS 0 MCS 15)	802.11n HT40 RATES (MCS 0 MCS 15)
36		10.5	10.5	
38	(36, 40)	11.0	11.0	11.0
40		11.0	11.0	
42		11.0	11.0	
44		11.0	11.0	
46	(44, 48)	11.0	11.0	12.5
48		11.0	11.0	
52		17.5	17.5	
54	(52, 56)	17.5	17.5	17
56		17.5	17.5	
60		17.5	17.5	
62	(60, 64)	17.5	17.5	11.5
64		11.5	11.5	
100		14.0	14.0	
102	(100, 104)	17.0	17.0	9.0
104		17.0	17.0	
108		17.0	17.0	
112		17.0	17.0	
110	(108, 112)	17.0	17.0	16.5
116		17.0	17.0	
118	(116, 120)	17.0	17.0	18.0
120		17.0	17.0	
124		17.0	17.0	
126	(124, 128)	17.0	17.0	18.0
128		17.0	17.0	

20 MHZ CHANNEL	40 MHZ CHANNEL	LEGACY OFDM RATES (6,9,12,18,24,36,48,54 MBPS)	802.11n HT20 RATES (MCS 0 MCS 15)	802.11n HT40 RATES (MCS 0 MCS 15)
132		17.0	17.0	
134	(132, 136)	17.0	17.0	14.0
136		17.0	17.0	
140		14.0	14.0	
149		19.0	19.0	
151	(149, 153)	19.0	19.0	18.0
153		19.0	19.0	
157		19.0	19.0	
159	(157, 161)	19.0	19.0	18.0
161		19.0	19.0	
165		19.0	19.0	

13.2.5 Panel Antenna Model

The following is the panel antenna model for 5.2 GHz:

Motorola Solutions Part Number
ML-2452-PNA5-01R

13.2.5.1 Panel Antenna Maximum Conducted Transmit Power Settings

The following is a transmit power table (US domain) per panel antenna in the 5 GHz band:

20 MHZ CHANNEL	40 MHZ CHANNEL	LEGACY OFDM RATES (6,9,12,18,24,36,48,54 MBPS)	802.11n HT20 RATES (MCS 0 MCS 15)	802.11n HT40 RATES (MCS 0 MCS 15)
36		10.5	12.0	
38	(36, 40)	11.0	12.0	11.0
40		11.0	12.0	
42		11.0	12.0	
44		11.0	12.0	
46	(44, 48)	11.0	12.0	12.5
48		11.0	12.0	
52		17.5	18.0	
54	(52, 56)	17.5	18.0	18.0
56		17.5	18.0	
60		17.5	18.0	
62	(60, 64)	17.5	18.0	12.0
64		15.0	13.5	
100		12.5	12.5	
102	(100, 104)	17.0	18.0	10.0
104		17.0	18.0	
108		17.0	18.0	
112		17.0	18.0	
110	(108, 112)	17.0	18.0	16.5
116		17.0	18.0	
118	(116, 120)	17.0	18.0	16.5
120		17.0	18.0	
124		17.0	18.0	
126	(124, 128)	17.0	18.0	16.5
128		17.0	18.0	

20 MHZ CHANNEL	40 MHZ CHANNEL	LEGACY OFDM RATES (6,9,12,18,24,36,48,54 MBPS)	802.11n HT20 RATES (MCS 0 MCS 15)	802.11n HT40 RATES (MCS 0 MCS 15)
132		17.0	18.0	
134	(132, 136)	17.0	18.0	13.5
136		17.0	18.0	
140		10.0	11.0	
149		19.0	18.0	
151	(149, 153)	19.0	18.0	18.0
153		19.0	18.0	
157		19.0	18.0	
159	(157, 161)	19.0	18.0	18.0
161		19.0	18.0	
165		19.0	18.0	

13.3 Japan TELEC Regulatory Domain 2.4 GHz Band

13.3.1 Dipole Antenna Model

The following is the dipole antenna model for 2.4 GHz:

Motorola Solutions Part Number
ML-2452-APA2-01

13.3.1.1 Dipole Antenna Maximum Conducted Transmit Power Settings

The following is a transmit power table (Japanese domain) per dipole antenna in the 2.4 GHz band:

20 MHZ CHANNEL	40 MHZ CHANNEL	LEGACY DSSS RATES (1, 2, 5.5, 11 MBPS)	LEGACY OFDM RATES (6,9,12,18,24,36, 48,54 MBPS)	802.11n HT20 RATES (MCS 0 MCS 15)	802.11n HT40 RATES (MCS 0 MCS15)
1		13.5	13.5	16.0	
2		13.5	13.5	15.5	
3	(1, 5)	13.5	13.5	15.5	18.5
4	(2, 6)	13.5	13.5	15.5	18.5
5	(3, 7)	13.5	13.5	15.5	18.5
6	(4, 8)	13.5	13.5	15.5	18.5
7	(5, 9)	13.5	13.5	15.5	18.5
8	(6, 10)	13.5	13.5	15.5	18.5
9	(7, 11)	13.5	13.5	15.5	18.5
10		13.5	13.5	15.5	
11		13.5	13.5	15.5	
12		13.5	13.5	15.5	
13		13.5	13.5	15.5	
14		14.0			

13.3.2 Internal AP650 Dual Band Antenna Models

The following is the internal dual band antenna model for 2.4 GHz:

Motorola Solutions Part Number
57RPAA13.G66
57RPAA13.G67
57RPAA13.G68
57RPAA13.G69
57RPAA13.G6A
57RPAA13.G6B

13.3.2.1 AP650 Internal Dual Band Antenna Maximum Conducted Transmit Power Settings

The following is a transmit power table (Japanese domain) per internal dual band antenna in the 2.4 GHz band:

20 MHZ CHANNEL	40 MHZ CHANNEL	LEGACY DSSS RATES (1, 2, 5.5, 11 MBPS)	LEGACY OFDM RATES (6,9,12,18,24,36, 48,54 MBPS)	802.11n HT20 RATES (MCS 0 MCS 15)	802.11n HT40 RATES (MCS 0 MCS15)
1		11.5	14.0	16.0	
2		11.5	14.0	16.0	
3	(1, 5)	11.5	14.0	16.0	18.5
4	(2, 6)	11.5	14.0	16.0	18.5
5	(3, 7)	11.5	14.0	16.0	18.5
6	(4, 8)	11.5	14.0	16.0	18.5
7	(5, 9)	11.5	14.0	16.0	18.5
8	(6, 10)	11.5	14.0	16.0	18.5
9	(7, 11)	11.5	14.0	16.0	18.5
10		11.5	14.0	16.0	18.5
11		11.5	14.0	16.0	18.5
12		11.5	14.0	16.0	18.5
13		11.5	14.0	16.0	
14		13.0			

13.3.3 Indoor Patch Antenna Model

The following is the indoor patch antenna model for 2.4 GHz:

Motorola Solutions Part Number
ML-2499-SD3-01R

13.3.3.1 Indoor Patch Antenna Maximum Conducted Transmit Power Settings

The following is a transmit power table (Japanese domain) per Indoor Patch antenna in the 2.4 GHz band:

20 MHZ CHANNEL	40 MHZ CHANNEL	LEGACY DSSS RATES (1, 2, 5.5, 11 MBPS)	LEGACY OFDM RATES (6,9,12,18,24,36, 48,54 MBPS)	802.11n HT20 RATES (MCS 0 MCS 15)	802.11n HT40 RATES (MCS 0 MCS15)
1		10.5	13.0	15.5	
2		10.5	13.0	15.5	
3	(1, 5)	10.5	13.0	15.5	18.5
4	(2, 6)	10.5	13.0	15.5	18.5
5	(3, 7)	10.5	13.0	15.5	18.5
6	(4, 8)	10.5	13.0	15.5	18.5
7	(5, 9)	10.5	13.0	15.5	18.5
8	(6, 10)	10.5	13.0	15.5	18.5
9	(7, 11)	10.5	13.0	15.5	18.5
10		10.5	13.0	15.5	
11		10.5	13.0	15.5	
12		10.5	13.0	15.5	
13		10.5	13.0	15.5	
14		11.5			

13.3.4 Outdoor Omni Antenna Model

The following is the outdoor omni antenna model for 2.4 GHz:

Motorola Solutions Part Number
ML-2499-HPA3-01R

13.3.4.1 Outdoor Omni Antenna Maximum Conducted Transmit Power Settings

The following is a transmit power table (Japanese domain) per outdoor omni antenna in the 2.4 GHz band:

20 MHZ CHANNEL	40 MHZ CHANNEL	LEGACY DSSS RATES (1, 2, 5.5, 11 MBPS)	LEGACY OFDM RATES (6,9,12,18,24,36, 48,54 MBPS)	802.11n HT20 RATES (MCS 0 MCS 15)	802.11n HT40 RATES (MCS0 MCS15)
1		10.5	13.0	15.5	
2		10.5	13.0	15.5	
3	(1, 5)	10.5	13.0	15.5	18.5
4	(2, 6)	10.5	13.0	15.5	18.5
5	(3, 7)	10.5	13.0	15.5	18.5
6	(4, 8)	10.5	13.0	15.5	18.5
7	(5, 9)	10.5	13.0	15.5	18.5
8	(6, 10)	10.5	13.0	15.5	18.5
9	(7, 11)	10.5	13.0	15.5	18.5
10		10.5	13.0	15.5	
11		10.5	13.0	15.5	
12		10.5	13.0	15.5	
13		10.5	13.0	15.5	
14		11.5			

13.3.5 Panel Antenna Models

The following is the panel antenna model for 2.4 GHz:

Motorola Solutions Part Number
ML-2452-PNA5-01R

13.3.5.1 Panel Antenna Maximum Conducted Transmit Power Settings

The following is a transmit power table (Japanese domain) per panel antenna in the 2.4 GHz band:

20 MHZ CHANNEL	40 MHZ CHANNEL	LEGACY DSSS RATES (1, 2, 5.5, 11 MBPS)	LEGACY OFDM RATES (6,9,12,18,24,36, 48,54 MBPS)	802.11n HT20 RATES (MCS 0 MCS 15)	802.11n HT40 RATES (MCS0 MCS15)
1		9.5	12.0	14.5	
2		9.5	12.0	14.5	
3	(1, 5)	9.5	12.0	14.5	18.5
4	(2, 6)	9.5	12.0	14.5	18.5
5	(3, 7)	9.5	12.0	14.5	18.5
6	(4, 8)	9.5	12.0	14.5	18.5
7	(5, 9)	9.5	12.0	14.5	18.5
8	(6, 10)	9.5	12.0	14.5	18.5
9	(7, 11)	9.5	12.0	14.5	18.5
10		9.5	12.0	14.5	
11		9.5	12.0	14.5	
12		9.5	12.0	14.5	
13		9.5	13.0	14.5	
14		10.5			

13.3.6 Omni Antenna Model

The following is the omni antenna model for 2.4 GHz:

Motorola Solutions Part Number
ML-2452-PTA3M3-036

13.3.6.1 Omni Antenna Maximum Conducted Transmit Power Settings

The following is a transmit power table (Japanese domain) per omni antenna in the 2.4 GHz band:

20 MHZ CHANNEL	40 MHZ CHANNEL	LEGACY DSSS RATES (1, 2, 5.5, 11 MBPS)	LEGACY OFDM RATES (6,9,12,18,24,36, 48,54 MBPS)	802.11n HT20 RATES (MCS 0 MCS 15)	802.11n HT40 RATES (MCS0 MCS15)
1		11.5	14.0	16.5	
2		11.5	14.0	16.5	
3	(1, 5)	11.5	14.0	16.5	18.5
4	(2, 6)	11.5	14.0	16.5	18.5
5	(3, 7)	11.5	14.0	16.5	18.5
6	(4, 8)	11.5	14.0	16.5	18.5
7	(5, 9)	11.5	14.0	16.5	18.5
8	(6, 10)	11.5	14.0	16.5	18.5
9	(7, 11)	11.5	14.0	16.5	18.5
10		11.5	14.0	16.5	
11		11.5	14.0	16.5	
12		11.5	14.0	16.5	
13		11.5	14.0	16.5	
14		10.0			

13.4 Japan TELEC Regulatory Domain 5 GHz Band

13.4.1 Dual Band Dipole Antenna Model

The following is the dual band dipole antenna model for 5 GHz:

Motorola Solutions Part Number
ML-2452-APA2-01

13.4.1.1 Dual Band Dipole Antenna Maximum Conducted Transmit Power Settings

The following is a transmit power table (Japanese domain) per dual band dipole antenna in the 5 GHz band:

20 MHZ CHANNEL	40 MHZ CHANNEL	LEGACY OFDM RATES (6,9,12,18,24,36,48,54 MBPS)	802.11n HT20 RATES (MCS 0 MCS 15)	802.11n HT40 RATES (MCS 0 MCS 15)
36		8.0	10.0	
38	(36, 40)	8.0	10.0	11.0
40		8.0	10.0	
42		8.0	10.0	
44		8.0	10.0	
46	(44, 48)	8.0	10.0	11.0
48		8.0	10.0	
52		8.0	10.0	
54	(52, 56)	8.0	10.0	11.0
56		8.0	10.0	
60		8.0	10.0	
62	(60, 64)	8.0	10.0	11.0
64		8.0	10.0	
100		15.0	17.0	
102	(100, 104)	15.0	17.0	18.0
104		15.0	17.0	
108		15.0	17.0	
112		15.0	17.0	
110	(108, 112)	15.0	17.0	18.0
116		15.0	17.0	
118	(116, 120)	15.0	17.0	18.0
120		15.0	17.0	
124		15.0	17.0	

20 MHZ CHANNEL	40 MHZ CHANNEL	LEGACY OFDM RATES (6,9,12,18,24,36,48,54 MBPS)	802.11n HT20 RATES (MCS 0 MCS 15)	802.11n HT40 RATES (MCS 0 MCS 15)
126	(124, 128)	15.0	17.0	18.0
128		15.0	17.0	
132		15.0	17.0	
134	(132, 136)	15.0	17.0	18.0
136		15.0	17.0	
140		15.0	17.0	
149				
151	(149, 153)			
153				
157				
159	(157, 161)			
161				
165				

13.4.2 Internal Dual Band Antenna Models

The following are the internal dual band antenna models for 5.2 GHz:

Motorola Solutions Part Number
57RPAA13.G66
57RPAA13.G67
57RPAA13.G68
57RPAA13.G69
57RPAA13.G6A
57RPAA13.G6B

13.4.2.1 Internal Dual Band Antenna Maximum Conducted Transmit Power Settings

The following is a transmit power table (Japanese domain) per internal dual band antenna in the 5 GHz band:

20 MHZ CHANNEL	40 MHZ CHANNEL	LEGACY OFDM RATES (6,9,12,18,24,36,48,54 MBPS)	802.11n HT20 RATES (MCS 0 MCS 15)	802.11n HT40 RATES (MCS 0 MCS 15)
36		12.0	14.0	
38	(36,40)	12.0	14.0	15.0
40		12.0	14.0	
42		12.0	14.0	
44		12.0	14.0	
46	(44,48)	12.0	14.0	15.5
48		12.0	14.0	
52		12.0	14.0	
54	(52,56)	12.0	14.0	15.5
56		12.0	14.0	
60		12.0	14.0	
62	(60,64)	12.0	14.0	15.5
64		12.0	14.0	
100		15.0	17.0	
102	(100,104)	15.0	17.0	18.0
104		15.0	17.0	
108		15.0	17.0	
112		15.0	17.0	
110	(108,112)	15.0	17.0	18.0
116		15.0	17.0	
118	(116,120)	15.0	17.0	18.0

20 MHZ CHANNEL	40 MHZ CHANNEL	LEGACY OFDM RATES (6,9,12,18,24,36,48,54 MBPS)	802.11n HT20 RATES (MCS 0 MCS 15)	802.11n HT40 RATES (MCS 0 MCS 15)
120		15.0	17.0	
124		15.0	17.0	
126	(124,128)	15.0	17.0	18.0
128		15.0	17.0	
132		15.0	17.0	
134	(132,136)	15.0	17.0	18.0
136		15.0	17.0	
140		15.0	17.0	
149				
151	(149,153)			
153				
157				
159	(157,161)			
161				
165				

13.4.3 Indoor Patch Model

The following is the indoor patch antenna model for 5.2 GHz:

Motorola Solutions Part Number
ML-5299-PTA1-01R

13.4.3.1 Indoor Patch Antenna Maximum Conducted Transmit Power Settings

The following is a transmit power table (Japanese domain) per indoor patch antenna in the 5 GHz band:

20 MHZ CHANNEL	40 MHZ CHANNEL	LEGACY OFDM RATES (6,9,12,18,24,36,48,54 MBPS)	802.11n HT20 RATES (MCS 0 MCS 15)	802.11n HT40 RATES (MCS 0 MCS 15)
36		12.0	14.0	
38	(36, 40)	12.0	14.0	15.0
40		12.0	14.0	
42		12.0	14.0	
44		12.0	14.0	
46	(44, 48)	12.0	14.0	15.5
48		12.0	14.0	
52		12.0	14.0	
54	(52, 56)	12.0	14.0	15.5
56		12.0	14.0	
60		12.0	14.0	
62	(60, 64)	12.0	14.0	15.5
64		12.0	14.0	
100		15.0	16.5	
102	(100, 104)	15.0	16.5	18.0
104		15.0	16.5	
108		15.0	16.5	
112		15.0	16.5	
110	(108, 112)	15.0	16.5	18.0
116		15.0	16.5	
118	(116, 120)	15.0	16.5	18.0
120		15.0	16.5	
124		15.0	16.5	
126	(124, 128)	15.0	16.5	18.0
128		15.0	16.5	

20 MHZ CHANNEL	40 MHZ CHANNEL	LEGACY OFDM RATES (6,9,12,18,24,36,48,54 MBPS)	802.11n HT20 RATES (MCS 0 MCS 15)	802.11n HT40 RATES (MCS 0 MCS 15)
132		15.0	16.5	
134	(132, 136)	15.0	16.5	18.0
136		15.0	16.5	
140		15.0	17.0	
149				
151	(149, 153)			
153				
157				
159	(157, 161)			
161				
165				

13.4.4 Outdoor Omni Antenna Model

The following is the outdoor omni antenna models for 5.2 GHz:

Motorola Solutions Part Number
ML-5299-HPA1-01R

13.4.4.1 Outdoor Omni Antenna Transmit Power Settings

The following is a transmit power table (Japanese domain) per outdoor omni antenna in the 5 GHz band:

20 MHZ CHANNEL	40 MHZ CHANNEL	LEGACY OFDM RATES (6,9,12,18,24,36,48,54 MBPS)	802.11n HT20 RATES (MCS 0 MCS 15)	802.11n HT40 RATES (MCS 0 MCS 15)
36		11.0	13.0	
38	(36, 40)	11.0	13.0	15.0
40		11.0	13.0	
42		11.0	13.0	
44		11.0	13.0	
46	(44, 48)	11.0	13.0	15.0
48		11.0	13.0	
52		11.0	13.0	
54	(52, 56)	11.0	13.0	15.0
56		11.0	13.0	
60		11.0	13.0	
62	(60, 64)	11.0	13.0	15.0
64		11.0	13.0	
100		15.0	17.0	
102	(100, 104)	15.0	17.0	18.0
104		15.0	17.0	
108		15.0	17.0	
112		15.0	17.0	
110	(108, 112)	15.0	17.0	18.0
116		15.0	17.0	
118	(116, 120)	15.0	17.0	18.0
120		15.0	17.0	
124		15.0	17.0	
126	(124, 128)	15.0	17.0	
128		15.0	17.0	

20 MHZ CHANNEL	40 MHZ CHANNEL	LEGACY OFDM RATES (6,9,12,18,24,36,48,54 MBPS)	802.11n HT20 RATES (MCS 0 MCS 15)	802.11n HT40 RATES (MCS 0 MCS 15)
132		15.0	16.5	
134	(132, 136)	15.0	16.5	18.0
136		15.0	16.5	
140		15.0	16.5	
149				
151	(149, 153)			
153				
157				
159	(157, 161)			
161				
165				

13.4.5 Panel Antenna Model

The following is the panel antenna model for 5.2 GHz:

Motorola Solutions Part Number
ML-2452-PNA5-01R

13.4.5.1 Panel Antenna Maximum Conducted Transmit Power Settings

The following is a transmit power table (Japanese domain) per panel antenna in the 5 GHz band:

20 MHZ CHANNEL	40 MHZ CHANNEL	LEGACY OFDM RATES (6,9,12,18,24,36,48,54 MBPS)	802.11n HT20 RATES (MCS 0 MCS 15)	802.11n HT40 RATES (MCS 0 MCS 15)
36		9.0	11.0	
38	(36, 40)	9.0	11.0	13.0
40		9.0	11.0	
42		9.0	11.0	
44		9.0	11.0	
46	(44, 48)	9.0	11.0	13.5
48		9.0	11.0	
52		9.0	11.0	
54	(52, 56)	9.0	11.0	13.5
56		9.0	11.0	
60		9.0	11.0	
62	(60, 64)	9.0	11.0	13.5
64		9.0	11.0	
100		15.0	16.5	
102	(100, 104)	15.0	16.5	18.0
104		15.0	16.5	
108		15.0	16.5	
112		15.0	16.5	
110	(108, 112)	15.0	16.5	18.0
116		15.0	16.5	
118	(116, 120)	15.0	16.5	18.0
120		15.0	16.5	
124		15.0	16.5	
126	(124, 128)	15.0	16.5	18.0
128		15.0	16.5	

20 MHZ CHANNEL	40 MHZ CHANNEL	LEGACY OFDM RATES (6,9,12,18,24,36,48,54 MBPS)	802.11n HT20 RATES (MCS 0 MCS 15)	802.11n HT40 RATES (MCS 0 MCS 15)
132		15.0	16.5	
134	(132, 136)	15.0	16.5	18.0
136		15.0	16.5	
140		15.0	17.0	
149				
151	(149, 153)			
153				
157				
159	(157, 161)			
161				
165				

13.4.6 Omni Antenna Model

The following is the omni antenna model for 5.2 GHz:

Motorola Solutions Part Number
ML-2452-PTA3M3-036

13.4.6.1 Omni Antenna Maximum Conducted Transmit Power Settings

The following is a transmit power table (Japanese domain) per omni antenna in the 5 GHz band:

20 MHZ CHANNEL	40 MHZ CHANNEL	LEGACY OFDM RATES (6,9,12,18,24,36,48,54 MBPS)	802.11n HT20 RATES (MCS 0 MCS 15)	802.11n HT40 RATES (MCS 0 MCS 15)
36		11.0	13.0	
38	(36, 40)	11.0	14.0	10.0
40		11.0	13.0	
42		11.0	13.0	
44		11.0	13.0	
46	(44, 48)	11.0	13.0	16.5
48		11.0	13.0	
52		11.0	13.0	
54	(52, 56)	11.0	13.0	17.0
56		11.0	13.0	
60		11.0	13.0	
62	(60, 64)	11.0	13.0	10.5
64		11.0	13.0	
100		15.0	16.5	
102	(100, 104)	15.0	16.5	8.0
104		15.0	16.5	
108		15.0	16.5	
112		15.0	16.5	
110	(108, 112)	15.0	16.5	16.0
116		15.0	16.5	
118	(116, 120)	15.0	16.5	16.0
120		15.0	16.5	
124		15.0	16.5	
126	(124, 128)	15.0	16.5	16.0
128		15.0	16.5	

20 MHZ CHANNEL	40 MHZ CHANNEL	LEGACY OFDM RATES (6,9,12,18,24,36,48,54 MBPS)	802.11n HT20 RATES (MCS 0 MCS 15)	802.11n HT40 RATES (MCS 0 MCS 15)
132		15.0	16.5	
134	(132, 136)	15.0	16.5	13.0
136		15.0	16.5	
140		15.0	17.0	
149				
151	(149, 153)			18.0
153				
157				
159	(157, 161)			18.0
161				
165				

13.5 EU Regulatory Domain 2.4 GHz Band

13.5.1 Dipole Antenna Model

The following is the dipole antenna model for 2.4 GHz:

Motorola Solutions Part Number
ML-2452-APA2-01

13.5.1.1 Dipole Antenna Maximum Conducted Transmit Power Settings

The following is a transmit power table (EU domain) per dipole antenna in the 2.4 GHz band:

20 MHZ CHANNEL	40 MHZ CHANNEL	LEGACY DSSS RATES (1, 2, 5.5, 11 MBPS)	LEGACY OFDM RATES (6,9,12,18,24,36, 48,54 MBPS)	802.11n HT20 RATES (MCS 0 MCS 15)	802.11n HT40 RATES (MCS 0 MCS15)
1		14.0	14.0	14.0	
2		14.0	14.0	14.0	
3	(1, 5)	14.0	14.0	14.0	14.0
4	(2, 6)	14.0	14.0	14.0	14.0
5	(3, 7)	14.0	14.0	14.0	14.0
6	(4, 8)	14.0	14.0	14.0	14.0
7	(5, 9)	14.0	14.0	14.0	14.0
8	(6, 10)	14.0	14.0	14.0	14.0
9	(7, 11)	14.0	14.0	14.0	14.0
10	(8, 12)	14.0	14.0	14.0	14.0
11	(9, 13)	14.0	14.0	14.0	14.0
12		14.0	14.0	14.0	
13		14.0	14.0	14.0	

13.5.2 Internal AP650 Dual Band Antenna Models

The following is the internal dual band antenna model for 2.4 GHz:

Motorola Solutions Part Number
57RPAA13.G66
57RPAA13.G67
57RPAA13.G68
57RPAA13.G69
57RPAA13.G6A
57RPAA13.G6B

13.5.2.1 AP650 Internal Dual Band Antenna Maximum Conducted Transmit Power Settings

The following is a transmit power table (EU domain) per internal dual band antenna in the 2.4 GHz band:

20 MHZ CHANNEL	40 MHZ CHANNEL	LEGACY DSSS RATES (1, 2, 5.5, 11 MBPS)	LEGACY OFDM RATES (6,9,12,18,24,36, 48,54 MBPS)	802.11n HT20 RATES (MCS 0 MCS 15)	802.11n HT40 RATES (MCS 0 MCS15)
1		15.0	15.0	15.0	
2		15.0	15.0	15.0	
3	(1, 5)	15.0	15.0	15.0	15.0
4	(2, 6)	15.0	15.0	15.0	15.0
5	(3, 7)	15.0	15.0	15.0	15.0
6	(4, 8)	15.0	15.0	15.0	15.0
7	(5, 9)	15.0	15.0	15.0	15.0
8	(6, 10)	15.0	15.0	15.0	15.0
9	(7, 11)	15.0	15.0	15.0	15.0
10	(8, 12)	15.0	15.0	15.0	15.0
11	(9, 13)	15.0	15.0	15.0	15.0
12		15.0	15.0	15.0	
13		15.0	15.0	15.0	

13.5.3 Outdoor Omni Antenna Model

The following is the outdoor omni antenna model for 2.4 GHz:

Motorola Solutions Part Number
ML-2499-HPA3-01R

13.5.3.1 Outdoor Omni Antenna Maximum Conducted Transmit Power Settings

The following is a transmit power table (EU domain) per outdoor omni antenna in the 2.4 GHz band:

20 MHZ CHANNEL	40 MHZ CHANNEL	LEGACY DSSS RATES (1, 2, 5.5, 11 MBPS)	LEGACY OFDM RATES (6,9,12,18,24,36, 48,54 MBPS)	802.11n HT20 RATES (MCS 0 MCS 15)	802.11n HT40 RATES (MCS0 MCS15)
1		14.0	14.0	14.0	
2		14.0	14.0	14.0	
3	(1, 5)	14.0	14.0	14.0	14.0
4	(2, 6)	14.0	14.0	14.0	14.0
5	(3, 7)	14.0	14.0	14.0	14.0
6	(4, 8)	14.0	14.0	14.0	14.0
7	(5, 9)	14.0	14.0	14.0	14.0
8	(6, 10)	14.0	14.0	14.0	14.0
9	(7, 11)	14.0	14.0	14.0	14.0
10	(8, 12)	14.0	14.0	14.0	14.0
11	(9, 13)	14.0	14.0	14.0	14.0
12		14.0	14.0	14.0	
13		14.0	14.0	14.0	

13.5.4 Panel Antenna Models

The following is the panel antenna model for 2.4 GHz:

Motorola Solutions Part Number
ML-2452-PNA5-01R

13.5.4.1 Panel Antenna Maximum Conducted Transmit Power Settings

The following is a transmit power table (EU domain) per panel antenna in the 2.4 GHz band:

20 MHZ CHANNEL	40 MHZ CHANNEL	LEGACY DSSS RATES (1, 2, 5.5, 11 MBPS)	LEGACY OFDM RATES (6,9,12,18,24,36, 48,54 MBPS)	802.11n HT20 RATES (MCS 0 MCS 15)	802.11n HT40 RATES (MCS0 MCS15)
1		13.0	13.0	13.0	
2		13.0	13.0	13.0	
3	(1, 5)	13.0	13.0	13.0	13.0
4	(2, 6)	13.0	13.0	13.0	13.0
5	(3, 7)	13.0	13.0	13.0	13.0
6	(4, 8)	13.0	13.0	13.0	13.0
7	(5, 9)	13.0	13.0	13.0	13.0
8	(6, 10)	13.0	13.0	13.0	13.0
9	(7, 11)	13.0	13.0	13.0	13.0
10	(8, 12)	13.0	13.0	13.0	13.0
11	(9, 13)	13.0	13.0	13.0	13.0
12		13.0	13.0	13.0	
13		13.0	13.0	13.0	

13.5.5 Patch Antenna Model

The following is the omni antenna model for 2.4 GHz:

Motorola Solutions Part Number
ML-2499- SD3-01R

13.5.5.1 Omni Antenna Maximum Conducted Transmit Power Settings

The following is a transmit power table (EU domain) per patch antenna in the 2.4 GHz band:

20 MHZ CHANNEL	40 MHZ CHANNEL	LEGACY DSSS RATES (1, 2, 5.5, 11 MBPS)	LEGACY OFDM RATES (6,9,12,18,24,36, 48,54 MBPS)	802.11n HT20 RATES (MCS 0 MCS 15)	802.11n HT40 RATES (MCS0 MCS15)
1		13.0	13.0	13.0	
2		13.0	13.0	13.0	
3	(1, 5)	13.0	13.0	13.0	13.0
4	(2, 6)	13.0	13.0	13.0	13.0
5	(3, 7)	13.0	13.0	13.0	13.0
6	(4, 8)	13.0	13.0	13.0	13.0
7	(5, 9)	13.0	13.0	13.0	13.0
8	(6, 10)	13.0	13.0	13.0	13.0
9	(7, 11)	13.0	13.0	13.0	13.0
10	(8, 12)	13.0	13.0	13.0	13.0
11	(9, 13)	13.0	13.0	13.0	13.0
12		13.0	13.0	13.0	
13		13.0	13.0	13.0	

13.6 EU Regulatory Domain 5 GHz Band

13.6.1 Dual Band Dipole Antenna Model

The following is the dual band dipole antenna model for 5 GHz:

Motorola Solutions Part Number
ML-2452-APA2-01

13.6.1.1 Dual Band Dipole Antenna Maximum Conducted Transmit Power Settings

The following is a transmit power table (EU domain) per dual band dipole antenna in the 5 GHz band:

20 MHZ CHANNEL	40 MHZ CHANNEL	LEGACY OFDM RATES (6,9,12,18,24,36,48,54 MBPS)	802.11n HT20 RATES (MCS 0 MCS 15)	802.11n HT40 RATES (MCS 0 MCS 15)
36		15.0	15.0	
38	(36, 40)	15.0	15.0	13.0
40		15.0	15.0	
42		15.0	15.0	
44		15.0	15.0	
46	(44, 48)	15.0	15.0	13.0
48		15.0	15.0	
52		19.0	19.0	
54	(52, 56)	19.0	19.0	19.0
56		19.0	19.0	
60		19.0	19.0	
62	(60, 64)	19.0	19.0	19.0
64		19.0	19.0	
100		19.0	19.0	
102	(100, 104)	19.0	19.0	19.0
104		19.0	19.0	
108		19.0	19.0	
112		19.0	19.0	
110	(108, 112)	19.0	19.0	19.0
116		19.0	19.0	
118	(116, 120)	19.0	19.0	19.0
120		19.0	19.0	
124		19.0	19.0	

20 MHZ CHANNEL	40 MHZ CHANNEL	LEGACY OFDM RATES (6,9,12,18,24,36,48,54 MBPS)	802.11n HT20 RATES (MCS 0 MCS 15)	802.11n HT40 RATES (MCS 0 MCS 15)
126	(124, 128)	19.0	19.0	19.0
128		19.0	19.0	
132		19.0	19.0	
134	(132, 136)	19.0	19.0	19.0
136		19.0	19.0	
140		19.0	19.0	
149				
151	(149, 153)			
153				
157				
159	(157, 161)			
161				
165				

13.6.2 Internal Dual Band Antenna Models

The following are the internal dual band antenna models for 5.2 GHz:

Motorola Solutions Part Number
57RPAA13.G66
57RPAA13.G67
57RPAA13.G68
57RPAA13.G69
57RPAA13.G6A
57RPAA13.G6B

13.6.2.1 Internal Dual Band Antenna Maximum Conducted Transmit Power Settings

The following is a transmit power table (EU domain) per internal dual band antenna in the 5 GHz band:

20 MHZ CHANNEL	40 MHZ CHANNEL	LEGACY OFDM RATES (6,9,12,18,24,36,48,54 MBPS)	802.11n HT20 RATES (MCS 0 MCS 15)	802.11n HT40 RATES (MCS 0 MCS 15)
36		15.0	15.0	
38	(36,40)	15.0	15.0	13.0
40		15.0	15.0	
42		15.0	15.0	
44		15.0	15.0	
46	(44,48)	15.0	15.0	13.0
48		15.0	15.0	
52		19.0	19.0	
54	(52,56)	19.0	19.0	19.0
56		19.0	19.0	
60		19.0	19.0	
62	(60,64)	19.0	19.0	19.0
64		19.0	19.0	
100		19.0	19.0	
102	(100,104)	19.0	19.0	19.0
104		19.0	19.0	
108		19.0	19.0	
112		19.0	19.0	
110	(108,112)	19.0	19.0	19.0
116		19.0	19.0	
118	(116,120)	19.0	19.0	19.0

20 MHZ CHANNEL	40 MHZ CHANNEL	LEGACY OFDM RATES (6,9,12,18,24,36,48,54 MBPS)	802.11n HT20 RATES (MCS 0 MCS 15)	802.11n HT40 RATES (MCS 0 MCS 15)
120		19.0	19.0	
124		19.0	19.0	
126	(124,128)	19.0	19.0	19.0
128		19.0	19.0	
132		19.0	19.0	
134	(132,136)	19.0	19.0	19.0
136		19.0	19.0	
140		19.0	19.0	
149				
151	(149,153)			
153				
157				
159	(157,161)			
161				
165				

13.6.3 Indoor Patch Model

The following is the indoor patch antenna model for 5.2 GHz:

Motorola Solutions Part Number
ML-5299-PTA1-01R

13.6.3.1 Indoor Patch Antenna Maximum Conducted Transmit Power Settings

The following is a transmit power table (EU domain) per indoor patch antenna in the 5 GHz band:

20 MHZ CHANNEL	40 MHZ CHANNEL	LEGACY OFDM RATES (6,9,12,18,24,36,48,54 MBPS)	802.11n HT20 RATES (MCS 0 MCS 15)	802.11n HT40 RATES (MCS 0 MCS 15)
36		13.0	13.0	
38	(36, 40)	13.0	13.0	13.0
40		13.0	13.0	
42		13.0	13.0	
44		13.0	13.0	
46	(44, 48)	13.0	13.0	13.0
48		13.0	13.0	
52		19.0	19.0	
54	(52, 56)	19.0	19.0	19.0
56		19.0	19.0	
60		19.0	19.0	
62	(60, 64)	19.0	19.0	19.0
64		19.0	19.0	
100		19.0	19.0	
102	(100, 104)	19.0	19.0	19.0
104		19.0	19.0	
108		19.0	19.0	
112		19.0	19.0	
110	(108, 112)	19.0	19.0	19.0
116		19.0	19.0	
118	(116, 120)	19.0	19.0	19.0
120		19.0	19.0	
124		19.0	19.0	
126	(124, 128)	19.0	19.0	19.0
128		19.0	19.0	

20 MHZ CHANNEL	40 MHZ CHANNEL	LEGACY OFDM RATES (6,9,12,18,24,36,48,54 MBPS)	802.11n HT20 RATES (MCS 0 MCS 15)	802.11n HT40 RATES (MCS 0 MCS 15)
132		19.0	19.0	
134	(132, 136)	19.0	19.0	19.0
136		19.0	19.0	
140		19.0	19.0	
149				
151	(149, 153)			
153				
157				
159	(157, 161)			
161				
165				

13.6.4 Outdoor Omni Antenna Model

The following is the outdoor omni antenna models for 5.2 GHz:

Motorola Solutions Part Number
ML-5299-HPA1-01R

13.6.4.1 Outdoor Omni Antenna Transmit Power Settings

The following is a transmit power table (EU domain) per outdoor omni antenna in the 5 GHz band:

20 MHZ CHANNEL	40 MHZ CHANNEL	LEGACY OFDM RATES (6,9,12,18,24,36,48,54 MBPS)	802.11n HT20 RATES (MCS 0 MCS 15)	802.11n HT40 RATES (MCS 0 MCS 15)
36		16.0	16.0	
38	(36, 40)	16.0	16.0	13.0
40		16.0	16.0	
42		16.0	16.0	
44		16.0	16.0	
46	(44, 48)	16.0	16.0	16.0
48		16.0	16.0	
52		19.0	19.0	
54	(52, 56)	19.0	19.0	19.0
56		19.0	19.0	
60		19.0	19.0	
62	(60, 64)	19.0	19.0	19.0
64		19.0	19.0	
100		19.0	19.0	
102	(100, 104)	19.0	19.0	19.0
104		19.0	19.0	
108		19.0	19.0	
112		19.0	19.0	
110	(108, 112)	19.0	19.0	19.0
116		19.0	19.0	
118	(116, 120)	19.0	19.0	19.0
120		19.0	19.0	
124		19.0	19.0	
126	(124, 128)	19.0	19.0	19.0
128		19.0	19.0	

20 MHZ CHANNEL	40 MHZ CHANNEL	LEGACY OFDM RATES (6,9,12,18,24,36,48,54 MBPS)	802.11n HT20 RATES (MCS 0 MCS 15)	802.11n HT40 RATES (MCS 0 MCS 15)
132		19.0	19.0	
134	(132, 136)	19.0	19.0	19.0
136		19.0	19.0	
140		19.0	19.0	
149				
151	(149, 153)			
153				
157				
159	(157, 161)			
161				
165				

13.6.5 Panel Antenna Model

The following is the panel antenna model for 5.2 GHz:

Motorola Solutions Part Number
ML-2452-PNA5-01R

13.6.5.1 Panel Antenna Maximum Conducted Transmit Power Settings

The following is a transmit power table (Japanese domain) per panel antenna in the 5 GHz band:

20 MHZ CHANNEL	40 MHZ CHANNEL	LEGACY OFDM RATES (6,9,12,18,24,36,48,54 MBPS)	802.11n HT20 RATES (MCS 0 MCS 15)	802.11n HT40 RATES (MCS 0 MCS 15)
36		16.0	16.0	
38	(36, 40)	16.0	16.0	13.0
40		16.0	16.0	
42		16.0	16.0	
44		16.0	16.0	
46	(44, 48)	16.0	16.0	16.0
48		16.0	16.0	
52		19.0	19.0	
54	(52, 56)	19.0	19.0	19.0
56		19.0	19.0	
60		19.0	19.0	
62	(60, 64)	19.0	19.0	19.0
64		19.0	19.0	
100		19.0	19.0	
102	(100, 104)	19.0	19.0	19.0
104		19.0	19.0	
108		19.0	19.0	
112		19.0	19.0	
110	(108, 112)	19.0	19.0	19.0
116		19.0	19.0	
118	(116, 120)	19.0	19.0	19.0
120		19.0	19.0	
124		19.0	19.0	
126	(124, 128)	19.0	19.0	
128		19.0	19.0	

20 MHZ CHANNEL	40 MHZ CHANNEL	LEGACY OFDM RATES (6,9,12,18,24,36,48,54 MBPS)	802.11n HT20 RATES (MCS 0 MCS 15)	802.11n HT40 RATES (MCS 0 MCS 15)
132		19.0	19.0	
134	(132, 136)	19.0	19.0	19.0
136		19.0	19.0	
140		19.0	19.0	
149				
151	(149, 153)			
153				
157				
159	(157, 161)			
161				
165				

RFS4011 Regulatory Domains

14.1 US Regulatory Domain 2.4 GHz Band

14.1.1 Facade Antenna Model

The following is the RFS4011 facade antenna model for 2.4 GHz, its peak gain is 2.1dBi:

<i>Motorola Part Number</i>
ML-2452-PTA4M3X3-1

14.1.1.1 Facade Antenna Maximum Conducted Transmit Power Settings

The following is a transmit power table (US domain) per facade antenna in the 2.4 GHz band:

20 MHZ CHANNEL	40 MHZ CHANNEL	LEGACY DSSS RATES (1, 2, 5.5, 11 MBPS)	LEGACY OFDM RATES (6,9,12,18,24,36, 48,54 MBPS)	802.11n HT20 RATES (MCS 0 MCS 15)	802.11n HT40 RATES (MCS 0 MCS15)
1		18.5	15.0	15.5	
2		18.5	15.0	15.5	
3	(1, 5)	18.5	15.0	15.5	12.5
4	(2, 6)	18.5	15.0	15.5	12.5
5	(3, 7)	18.5	15.0	15.5	12.5
6	(4, 8)	21.0	15.0	16.0	15.5
7	(5, 9)	20.0	15.5	15.5	12.5
8	(6, 10)	20.0	15.5	15.5	12.5
9	(7, 11)	20.0	15.5	15.5	12.5
10		20.0	15.5	15.5	
11		20.0	15.5	15.5	

14.1.2 MIMO Patch Antenna Model

The following is the RFS4011 MIMO patch antenna model for 2.4 GHz, its peak gain is 3.5dBi:

Motorola Part Number
ML-2452-PTA3M3-036

14.1.2.1 MIMO Patch Antenna Maximum Conducted Transmit Power Settings

The following is a transmit power table (US domain) per MIMO patch antenna in the 2.4 GHz band:

20 MHZ CHANNEL	40 MHZ CHANNEL	LEGACY DSSS RATES (1, 2, 5.5, 11 MBPS)	LEGACY OFDM RATES (6,9,12,18,24,36, 48,54 MBPS)	802.11n HT20 RATES (MCS 0 MCS 15)	802.11n HT40 RATES (MCS 0 MCS15)
1		18.5	13.5	14.5	
2		18.5	13.5	14.5	
3	(1, 5)	18.5	13.5	14.5	11.5
4	(2, 6)	18.5	13.5	14.5	11.5
5	(3, 7)	18.5	13.5	14.5	11.5
6	(4, 8)	19.5	14.0	16.0	15.5
7	(5, 9)	19.0	14.0	14.5	11.5
8	(6, 10)	19.0	14.0	14.5	11.5
9	(7, 11)	19.0	14.0	14.5	11.5
10		19.0	14.0	14.5	
11		19.0	14.0	14.5	

14.1.3 Dipole Antenna Model

The following is the RFS4011 dipole antenna model for 2.4 GHz, its peak gain is 3.1dBi:

Motorola Part Number
ML-2452-HPA5-036

14.1.3.1 Dipole Antenna Maximum Conducted Transmit Power Settings

The following is a transmit power table (US domain) per dipole antenna in the 2.4 GHz band:

20 MHZ CHANNEL	40 MHZ CHANNEL	LEGACY DSSS RATES (1, 2, 5.5, 11 MBPS)	LEGACY OFDM RATES (6,9,12,18,24,36, 48,54 MBPS)	802.11n HT20 RATES (MCS 0 MCS 15)	802.11n HT40 RATES (MCS 0 MCS15)
1		19.0	14.0	14.0	
2		19.0	14.0	14.0	
3	(1, 5)	19.0	14.0	14.0	11.0
4	(2, 6)	19.0	14.0	14.0	11.0
5	(3, 7)	19.0	14.0	14.0	11.0
6	(4, 8)	20.0	15.0	15.5	14.0
7	(5, 9)	18.5	13.5	13.5	11.0
8	(6, 10)	18.5	13.5	13.5	11.0
9	(7, 11)	18.5	13.5	13.5	11.0
10		18.5	13.5	13.5	
11		18.5	13.5	13.5	

14.1.4 High-Gain Patch Antenna Model

The following is the RFS4011 high-gain patch antenna model for 2.4 GHz, its peak gain is 7.5 dBi:

Motorola Part Number
ML-2452-PNA7-01R

14.1.4.1 High-Gain Patch Antenna Maximum Conducted Transmit Power Settings

The following is a transmit power table (US domain) per high-gain patch antenna in the 2.4 GHz band:

20 MHZ CHANNEL	40 MHZ CHANNEL	LEGACY DSSS RATES (1, 2, 5.5, 11 MBPS)	LEGACY OFDM RATES (6,9,12,18,24,36, 48,54 MBPS)	802.11n HT20 RATES (MCS 0 MCS 15)	802.11n HT40 RATES (MCS0 MCS15)
1		15.5	9.5	11.0	
2		15.5	9.5	11.0	
3	(1, 5)	15.5	9.5	11.0	7.5
4	(2, 6)	15.5	9.5	11.0	7.5
5	(3, 7)	15.5	9.5	11.0	7.5
6	(4, 8)	15.5	10.5	15.0	12.5
7	(5, 9)	16.0	9.5	11.0	8.0
8	(6, 10)	16.0	9.5	11.0	8.0
9	(7, 11)	16.0	9.5	11.0	8.0
10		16.0	9.5	11.0	
11		16.0	9.5	11.0	

14.2 US Regulatory Domain 5 GHz Band

14.2.1 Facade Antenna Model

The following is the RFS4011 facade antenna model for 5 GHz, its peak gain is 3.95dBi:

<i>Motorola Part Number</i>
ML-2452-PTA4M3X3-1

14.2.1.1 Facade Antenna Maximum Conducted Transmit Power Settings

The following is a transmit power table (US domain) per facade antenna in the 5 GHz band:

20 MHZ CHANNEL	40 MHZ CHANNEL	LEGACY OFDM RATES (6,9,12,18,24,36,48,54 MBPS)	802.11n HT20 RATES (MCS 0 MCS 15)	802.11n HT40 RATES (MCS 0 MCS 15)
36		8.5	10.0	
38	(36, 40)			10.0
40		8.5	10.0	
42		8.5	10.0	
44		8.5	10.0	
46	(44, 48)			10.0
48		8.5	10.0	
52				
54	(52, 56)			
56				
60				
62	(60, 64)			
64				
100				
102	(100, 104)			
104				
108				
112				
110	(108, 112)			
116				
118	(116, 120)			
120				
124				
126	(124, 128)			
128				

20 MHZ CHANNEL	40 MHZ CHANNEL	LEGACY OFDM RATES (6,9,12,18,24,36,48,54 MBPS)	802.11n HT20 RATES (MCS 0 MCS 15)	802.11n HT40 RATES (MCS 0 MCS 15)
132				
134	(132, 136)			
136				
140				
149		11.0	12.5	
151	(149, 153)			12.5
153		11.0	12.5	
157		11.5	12.5	
159	(157, 161)			13.0
161		12.0	13.0	
165		12.0	13.0	

14.2.2 MIMO Patch Antenna Model

The following is the RFS4011 MIMO patch antenna model for 5 GHz, its peak gain is 5.0dBi:

Motorola Part Number
ML-2452-PTA3M3-036

14.2.2.1 MIMO Patch Antenna Maximum Conducted Transmit Power Settings

The following is a transmit power table (US domain) per MIMO patch antenna in the 5 GHz band:

20 MHZ CHANNEL	40 MHZ CHANNEL	LEGACY OFDM RATES (6,9,12,18,24,36,48,54 MBPS)	802.11n HT20 RATES (MCS 0 MCS 15)	802.11n HT40 RATES (MCS 0 MCS 15)
36		7.5	11.0	
38	(36,40)			11.0
40		7.5	11.0	
42		7.5	11.0	
44		7.5	11.0	
46	(44,48)			11.0
48		7.5	11.0	
52				
54	(52,56)			
56				
60				
62	(60,64)			
64				
100				
102	(100,104)			
104				
108				
112				
110	(108,112)			
116				
118	(116,120)			
120				
124				
126	(124,128)			
128				

20 MHZ CHANNEL	40 MHZ CHANNEL	LEGACY OFDM RATES (6,9,12,18,24,36,48,54 MBPS)	802.11n HT20 RATES (MCS 0 MCS 15)	802.11n HT40 RATES (MCS 0 MCS 15)
132				
134	(132,136)			
136				
140				
149		10.5	13.5	
151	(149,153)			13.5
153		10.5	13.5	
157		11.0	13.5	
159	(157,161)			14.0
161		11.5	14.0	
165		11.5	14.0	

14.2.3 Dipole Model

The following is the RFS4011 dipole antenna model for 5 GHz, its peak gain is 4.6dBi:

Motorola Part Number
ML-2452-HPA5-036

14.2.3.1 Dipole Antenna Maximum Conducted Transmit Power Settings

The following is a transmit power table (US domain) per dipole antenna in the 5 GHz band:

20 MHZ CHANNEL	40 MHZ CHANNEL	LEGACY OFDM RATES (6,9,12,18,24,36,48,54 MBPS)	802.11n HT20 RATES (MCS 0 MCS 15)	802.11n HT40 RATES (MCS 0 MCS 15)
36		8.0	11.0	
38	(36, 40)			11.0
40		8.0	11.0	
42		8.0	11.0	
44		8.0	11.0	
46	(44, 48)			11.0
48		8.0	11.0	
52				
54	(52, 56)			
56				
60				
62	(60, 64)			
64				
100				
102	(100, 104)			
104				
108				
112				
110	(108, 112)			
116				
118	(116, 120)			
120				
124				
126	(124, 128)			
128				
132				
134	(132, 136)			

20 MHZ CHANNEL	40 MHZ CHANNEL	LEGACY OFDM RATES (6,9,12,18,24,36,48,54 MBPS)	802.11n HT20 RATES (MCS 0 MCS 15)	802.11n HT40 RATES (MCS 0 MCS 15)
136				
140				
149		10.5	13.5	
151	(149, 153)			13.5
153		10.5	13.5	
157		11.0	13.5	
159	(157, 161)			14.0
161		11.5	14.0	
165		11.5	14.0	

14.2.4 High-Gain Patch Antenna Model

The following is the RFS4011 high-gain patch antenna model for 5 GHz, its peak gain is between 6.3 -10dBi:

Motorola Part Number
ML-2452-PNA7-01R

14.2.4.1 High-Gain Patch Antenna Transmit Power Settings

The following is a transmit power table (US domain) per high-gain patch antenna in the 5 GHz band:

20 MHZ CHANNEL	40 MHZ CHANNEL	LEGACY OFDM RATES (6,9,12,18,24,36,48,54 MBPS)	802.11n HT20 RATES (MCS 0 MCS 15)	802.11n HT40 RATES (MCS 0 MCS 15)
36		6.5	10.5	
38	(36, 40)			9.5
40		6.5	10.5	
42		6.5	10.5	
44		6.5	10.5	
46	(44, 48)			9.5
48		6.5	10.5	
52				
54	(52, 56)			
56				
60				
62	(60, 64)			
64				
100				
102	(100, 104)			
104				
108				
112				
110	(108, 112)			
116				
118	(116, 120)			
120				
124				
126	(124, 128)			
128				

20 MHZ CHANNEL	40 MHZ CHANNEL	LEGACY OFDM RATES (6,9,12,18,24,36,48,54 MBPS)	802.11n HT20 RATES (MCS 0 MCS 15)	802.11n HT40 RATES (MCS 0 MCS 15)
132				
134	(132, 136)			
136				
140				
149		6.5	11.0	
151	(149, 153)			11.0
153		6.5	11.0	
157		7.0	11.0	
159	(157, 161)			11.5
161		7.5	11.5	
165		7.5	11.5	

14.3 Canada Regulatory Domain 2.4 GHz Band

14.3.1 Facade Antenna Model

The following is the RFS4011 facade antenna model for 2.4 GHz, its peak gain is 2.1dBi:

<i>Motorola Part Number</i>
ML-2452-PTA4M3X3-1

14.3.1.1 Facade Antenna Maximum Conducted Transmit Power Settings

The following is a transmit power table (Canadian domain) per facade antenna in the 2.4 GHz band:

20 MHZ CHANNEL	40 MHZ CHANNEL	LEGACY DSSS RATES (1, 2, 5.5, 11 MBPS)	LEGACY OFDM RATES (6,9,12,18,24,36, 48,54 MBPS)	802.11n HT20 RATES (MCS 0 MCS 15)	802.11n HT40 RATES (MCS 0 MCS15)
1		18.5	16.0	15.5	
2		18.5	16.0	15.5	
3	(1, 5)	18.5	16.0	15.5	12.5
4	(2, 6)	18.5	16.0	15.5	12.5
5	(3, 7)	18.5	16.0	15.5	12.5
6	(4, 8)	21.0	16.0	16.0	15.5
7	(5, 9)	20.0	16.0	15.5	12.5
8	(6, 10)	20.0	16.0	15.5	12.5
9	(7, 11)	20.0	16.0	15.5	12.5
10		20.0	16.0	15.5	
11		20.0	16.0	15.5	

14.3.2 MIMO Patch Antenna Model

The following is the RFS4011 MIMO patch antenna model for 2.4 GHz, its peak gain is 3.5dBi:

Motorola Part Number
ML-2452-PTA3M3-036

14.3.2.1 MIMO Patch Antenna Maximum Conducted Transmit Power Settings

The following is a transmit power table (Canadian domain) per MIMO patch antenna in the 2.4 GHz band:

20 MHZ CHANNEL	40 MHZ CHANNEL	LEGACY DSSS RATES (1, 2, 5.5, 11 MBPS)	LEGACY OFDM RATES (6,9,12,18,24,36, 48,54 MBPS)	802.11n HT20 RATES (MCS 0 MCS 15)	802.11n HT40 RATES (MCS 0 MCS15)
1		18.5	16.0	14.5	
2		18.5	16.0	14.5	
3	(1, 5)	18.5	16.0	14.5	11.5
4	(2, 6)	18.5	16.0	14.5	11.5
5	(3, 7)	18.5	16.0	14.5	11.5
6	(4, 8)	21.0	16.0	16.0	15.5
7	(5, 9)	19.0	16.0	14.5	11.5
8	(6, 10)	19.0	16.0	14.5	11.5
9	(7, 11)	19.0	16.0	14.5	11.5
10		19.0	16.0	14.5	
11		19.0	16.0	14.5	

14.3.3 Dipole Antenna Model

The following is the RFS4011 dipole antenna model for 2.4 GHz, its peak gain is 3.1dBi:

Motorola Part Number
ML-2452-HPA5-036

14.3.3.1 Dipole Antenna Maximum Conducted Transmit Power Settings

The following is a transmit power table (Canadian domain) per dipole antenna in the 2.4 GHz band:

20 MHZ CHANNEL	40 MHZ CHANNEL	LEGACY DSSS RATES (1, 2, 5.5, 11 MBPS)	LEGACY OFDM RATES (6,9,12,18,24,36, 48,54 MBPS)	802.11n HT20 RATES (MCS 0 MCS 15)	802.11n HT40 RATES (MCS 0 MCS15)
1		19.0	14.0	14.0	
2		19.0	14.0	14.0	
3	(1, 5)	19.0	14.0	14.0	11.0
4	(2, 6)	19.0	14.0	14.0	11.0
5	(3, 7)	19.0	14.0	14.0	11.0
6	(4, 8)	21.5	15.5	15.5	14.0
7	(5, 9)	18.5	13.5	13.5	11.0
8	(6, 10)	18.5	13.5	13.5	11.0
9	(7, 11)	18.5	13.5	13.5	11.0
10		18.5	13.5	13.5	
11		18.5	13.5	13.5	

14.3.4 High-Gain Antenna Model

The following is the RFS4011 high-gain antenna model for 2.4 GHz, its peak gain is 7.5dBi:

Motorola Part Number
ML-2452-PNA7-01R

14.3.4.1 High-Gain Antenna Maximum Conducted Transmit Power Settings

The following is a transmit power table (Canadian domain) per high-gain antenna in the 2.4 GHz band:

20 MHZ CHANNEL	40 MHZ CHANNEL	LEGACY DSSS RATES (1, 2, 5.5, 11 MBPS)	LEGACY OFDM RATES (6,9,12,18,24,36, 48,54 MBPS)	802.11n HT20 RATES (MCS 0 MCS 15)	802.11n HT40 RATES (MCS0 MCS15)
1		17.0	11.0	11.0	
2		17.0	11.0	11.0	
3	(1, 5)	17.0	11.0	11.0	7.5
4	(2, 6)	17.0	11.0	11.0	7.5
5	(3, 7)	17.0	11.0	11.0	7.5
6	(4, 8)	20.0	15.0	15.0	12.5
7	(5, 9)	17.0	11.0	11.0	8.0
8	(6, 10)	17.0	11.0	11.0	8.0
9	(7, 11)	17.0	11.0	11.0	8.0
10		17.0	11.0	11.0	
11		17.0	11.0	11.0	

14.4 Canada Regulatory Domain 5 GHz Band

14.4.1 Facade Antenna Model

The following is the RFS4011 facade antenna model for 5 GHz, its peak gain is 3.95dBi:

<i>Motorola Part Number</i>
ML-2452-PTA4M3X3-1

14.4.1.1 Facade Antenna Maximum Conducted Transmit Power Settings

The following is a transmit power table (Canadian domain) per facade antenna in the 5 GHz band:

20 MHZ CHANNEL	40 MHZ CHANNEL	LEGACY OFDM RATES (6,9,12,18,24,36,48,54 MBPS)	802.11n HT20 RATES (MCS 0 MCS 15)	802.11n HT40 RATES (MCS 0 MCS 15)
36		10.0	10.0	
38	(36, 40)			10.0
40		10.0	10.0	
42		10.0	10.0	
44		10.0	10.0	
46	(44, 48)			10.0
48		10.0	10.0	
52				
54	(52, 56)			
56				
60				
62	(60, 64)			
64				
100				
102	(100, 104)			
104				
108				
112				
110	(108, 112)			
116				
118	(116, 120)			
120				
124				

20 MHZ CHANNEL	40 MHZ CHANNEL	LEGACY OFDM RATES (6,9,12,18,24,36,48,54 MBPS)	802.11n HT20 RATES (MCS 0 MCS 15)	802.11n HT40 RATES (MCS 0 MCS 15)
126	(124, 128)			
128				
132				
134	(132, 136)			
136				
140				
149		12.5	12.5	
151	(149, 153)			12.5
153		12.5	12.5	
157		12.5	12.5	
159	(157, 161)			13.0
161		13.0	13.0	
165		13.0	13.0	

14.4.2 MIMO Patch Antenna Model

The following is the RFS4011 MIMO patch antenna model for 5 GHz, its peak gain is 5dBi:

Motorola Part Number
ML-2452-PTA3M3-036

14.4.2.1 MIMO Patch Antenna Maximum Conducted Transmit Power Settings

The following is a transmit power table (Canadian domain) per MIMO patch antenna in the 5 GHz band:

20 MHZ CHANNEL	40 MHZ CHANNEL	LEGACY OFDM RATES (6,9,12,18,24,36,48,54 MBPS)	802.11n HT20 RATES (MCS 0 MCS 15)	802.11n HT40 RATES (MCS 0 MCS 15)
36		11.0	11.0	
38	(36,40)			11.0
40		11.0	11.0	
42		11.0	11.0	
44		11.0	11.0	
46	(44,48)			11.0
48		11.0	11.0	
52				
54	(52,56)			
56				
60				
62	(60,64)			
64				
100				
102	(100,104)			
104				
108				
112				
110	(108,112)			
116				
118	(116,120)			
120				
124				
126	(124,128)			
128				

20 MHZ CHANNEL	40 MHZ CHANNEL	LEGACY OFDM RATES (6,9,12,18,24,36,48,54 MBPS)	802.11n HT20 RATES (MCS 0 MCS 15)	802.11n HT40 RATES (MCS 0 MCS 15)
132				
134	(132,136)			
136				
140				
149		13.5	13.5	
151	(149,153)			13.5
153		13.5	13.5	
157		13.5	13.5	
159	(157,161)			14.0
161		14.0	14.0	
165		14.0	14.0	

14.4.3 Dipole Antenna Model

The following is the RFS4011 dipole antenna model for 5 GHz, its peak gain is 4.6dBi:

Motorola Part Number
ML-2452-HPA5-036

14.4.3.1 Dipole Antenna Maximum Conducted Transmit Power Settings

The following is a transmit power table (Canadian domain) per dipole antenna in the 5 GHz band:

20 MHZ CHANNEL	40 MHZ CHANNEL	LEGACY OFDM RATES (6,9,12,18,24,36,48,54 MBPS)	802.11n HT20 RATES (MCS 0 MCS 15)	802.11n HT40 RATES (MCS 0 MCS 15)
36		11.0	11.0	
38	(36, 40)			11.0
40		11.0	11.0	
42		11.0	11.0	
44		11.0	11.0	
46	(44, 48)			11.0
48		11.0	11.0	
52				
54	(52, 56)			
56				
60				
62	(60, 64)			
64				
100				
102	(100, 104)			
104				
108				
112				
110	(108, 112)			
116				
118	(116, 120)			
120				
124				
126	(124, 128)			
128				

20 MHZ CHANNEL	40 MHZ CHANNEL	LEGACY OFDM RATES (6,9,12,18,24,36,48,54 MBPS)	802.11n HT20 RATES (MCS 0 MCS 15)	802.11n HT40 RATES (MCS 0 MCS 15)
132				
134	(132, 136)			
136				
140				
149		13.5	13.5	
151	(149, 153)			13.5
153		13.5	13.5	
157		13.5	13.5	
159	(157, 161)			14.0
161		14.0	14.0	
165		14.0	14.0	

14.4.4 High-Gain Antenna Model

The following is the high-gain antenna model for 5 GHz, its peak gain is from 6.3 - 10dBi:

Motorola Part Number
ML-2452-PNA7-01R

14.4.4.1 High-Gain Antenna Transmit Power Settings

The following is a transmit power table (Canadian domain) per high-gain antenna in the 5 GHz band:

20 MHZ CHANNEL	40 MHZ CHANNEL	LEGACY OFDM RATES (6,9,12,18,24,36,48,54 MBPS)	802.11n HT20 RATES (MCS 0 MCS 15)	802.11n HT40 RATES (MCS 0 MCS 15)
36		10.5	10.5	
38	(36, 40)			9.5
40		10.5	10.5	
42		10.5	10.5	
44		10.5	10.5	
46	(44, 48)			9.5
48		10.5	10.5	
52				
54	(52, 56)			
56				
60				
62	(60, 64)			
64				
100				
102	(100, 104)			
104				
108				
112				
110	(108, 112)			
116				
118	(116, 120)			
120				
124				
126	(124, 128)			
128				

20 MHZ CHANNEL	40 MHZ CHANNEL	LEGACY OFDM RATES (6,9,12,18,24,36,48,54 MBPS)	802.11n HT20 RATES (MCS 0 MCS 15)	802.11n HT40 RATES (MCS 0 MCS 15)
132				
134	(132, 136)			
136				
140				
149		11.0	11.0	
151	(149, 153)			11.0
153		11.0	11.0	
157		11.0	11.0	
159	(157, 161)			11.5
161		11.5	11.5	
165		11.5	11.5	

14.5 EU Regulatory Domain 2.4 GHz Band

14.5.1 Facade Antenna Model

The following is the RFS4011 facade antenna model for 2.4 GHz, the peak gain is 2.1dBi:

Motorola Part Number
ML-2452-PTA4M3X3-1

14.5.1.1 Facade Antenna Maximum Conducted Transmit Power Settings

The following is a transmit power table (EU domain) per facade antenna in the 2.4 GHz band:

20 MHZ CHANNEL	40 MHZ CHANNEL	LEGACY DSSS RATES (1, 2, 5.5, 11 MBPS)	LEGACY OFDM RATES (6,9,12,18,24,36, 48,54 MBPS)	802.11n HT20 RATES (MCS 0 MCS 15)	802.11n HT40 RATES (MCS 0 MCS15)
1		6.5	4.0	4.0	
2		6.0	3.5	3.5	
3	(1, 5)	6.0	3.5	3.5	4.0
4	(2, 6)	6.0	3.5	3.5	3.5
5	(3, 7)	6.0	3.5	3.5	3.5
6	(4, 8)	6.0	3.5	3.5	3.5
7	(5, 9)	6.0	3.5	3.5	3.5
8	(6, 10)	6.0	3.5	3.5	3.5
9	(7, 11)	6.0	3.5	3.5	3.5
10		6.0	3.5	3.5	3.5
11		6.0	3.5	3.5	3.5
12		6.0	3.5	3.5	
13		6.0	3.5	3.5	
14					

14.5.2 MIMO Patch Antenna Model

The following is the RFS4011 MIMO patch antenna model for 2.4 GHz, its peak gain is 3.5dBi:

Motorola Part Number
ML-2452-PTA3M3-036

14.5.2.1 MIMO Patch Antenna Maximum Conducted Transmit Power Settings

The following is a transmit power table (EU domain) per MIMO patch antenna in the 2.4 GHz band:

20 MHZ CHANNEL	40 MHZ CHANNEL	LEGACY DSSS RATES (1, 2, 5.5, 11 MBPS)	LEGACY OFDM RATES (6,9,12,18,24,36, 48,54 MBPS)	802.11n HT20 RATES (MCS 0 MCS 15)	802.11n HT40 RATES (MCS 0 MCS15)
1		7.5	5.5	5.5	
2		7.5	5.5	5.5	
3	(1, 5)	7.5	5.5	5.5	6.0
4	(2, 6)	7.5	5.5	5.5	6.0
5	(3, 7)	7.5	5.5	5.5	6.0
6	(4, 8)	7.5	5.5	5.5	6.0
7	(5, 9)	7.5	5.5	5.5	6.0
8	(6, 10)	7.5	5.5	5.5	6.0
9	(7, 11)	7.5	5.5	5.5	6.0
10		7.5	5.5	5.5	6.0
11		7.5	5.5	5.5	6.0
12		7.5	5.5	5.5	
13		7.5	5.5	5.5	
14					

14.5.3 Dipole Antenna Model

The following is the RFS4011 dipole antenna model for 2.4 GHz, its peak gain is 3.1dBi:

Motorola Part Number
ML-2452-HPA5-036

14.5.3.1 Dipole Antenna Maximum Conducted Transmit Power Settings

The following is a transmit power table (EU domain) per dipole antenna in the 2.4 GHz band:

20 MHZ CHANNEL	40 MHZ CHANNEL	LEGACY DSSS RATES (1, 2, 5.5, 11 MBPS)	LEGACY OFDM RATES (6,9,12,18,24,36, 48,54 MBPS)	802.11n HT20 RATES (MCS 0 MCS 15)	802.11n HT40 RATES (MCS 0 MCS15)
1		8.5	6.5	6.5	
2		8.5	6.5	6.5	
3	(1, 5)	8.5	6.5	6.5	7.0
4	(2, 6)	8.5	6.5	6.5	7.0
5	(3, 7)	8.5	6.5	6.5	7.0
6	(4, 8)	8.5	6.5	6.5	7.0
7	(5, 9)	8.5	6.5	6.5	7.0
8	(6, 10)	8.5	6.5	6.5	7.0
9	(7, 11)	8.5	6.5	6.5	7.0
10		8.5	6.5	6.5	7.0
11		8.5	6.5	6.5	7.0
12		8.5	6.5	6.5	
13		8.5	6.5	6.5	
14					

14.5.4 High-Gain Antenna Model

The following is the RFS4011 high-gain antenna model for 2.4 GHz, its peak gain is 7.5dBi:

Motorola Part Number
ML-2452-PNA7-01R

14.5.4.1 High-Gain Antenna Maximum Conducted Transmit Power Settings

The following is a transmit power table (EU domain) per high-gain antenna in the 2.4 GHz band:

20 MHZ CHANNEL	40 MHZ CHANNEL	LEGACY DSSS RATES (1, 2, 5.5, 11 MBPS)	LEGACY OFDM RATES (6,9,12,18,24,36, 48,54 MBPS)	802.11n HT20 RATES (MCS 0 MCS 15)	802.11n HT40 RATES (MCS0 MCS15)
1		3.0	1.0	1.0	
2		3.0	0.5	0.5	
3	(1, 5)	3.0	0.5	0.5	1.0
4	(2, 6)	3.0	0.5	0.5	0.5
5	(3, 7)	3.0	0.5	0.5	0.5
6	(4, 8)	3.0	0.5	0.5	0.5
7	(5, 9)	3.0	0.5	0.5	0.5
8	(6, 10)	3.0	0.5	0.5	0.5
9	(7, 11)	3.0	0.5	0.5	0.5
10		3.0	0.5	0.5	0.5
11		3.0	0.5	0.5	0.5
12		3.0	0.5	0.5	
13		3.0	1.0	0.5	
14					

14.6 EU Regulatory Domain 5 GHz Band

14.6.1 Facade Antenna Model

The following is the RFS4011 facade antenna model for 5 GHz, its peak gain is 3.95dBi:

<i>Motorola Part Number</i>
ML-2452-PTA4M3X3-1

14.6.1.1 Facade Antenna Maximum Conducted Transmit Power Settings

The following is a transmit power table (EU domain) per facade antenna in the 5 GHz band:

20 MHZ CHANNEL	40 MHZ CHANNEL	LEGACY OFDM RATES (6,9,12,18,24,36,48,54 MBPS)	802.11n HT20 RATES (MCS 0 MCS 15)	802.11n HT40 RATES (MCS 0 MCS 15)
36		8.5	8.5	
38	(36, 40)			9.5
40		8.5	8.5	
42		8.5	8.5	
44		8.5	8.5	
46	(44, 48)			10.0
48		9.0	9.0	
52				
54	(52, 56)			
56				
60				
62	(60, 64)			
64				
100				
102	(100, 104)			
104				
108				
112				
110	(108, 112)			
116				
118	(116, 120)			
120				
124				

20 MHZ CHANNEL	40 MHZ CHANNEL	LEGACY OFDM RATES (6,9,12,18,24,36,48,54 MBPS)	802.11n HT20 RATES (MCS 0 MCS 15)	802.11n HT40 RATES (MCS 0 MCS 15)
126	(124, 128)			
128				
132				
134	(132, 136)			
136				
140				
149				
151	(149, 153)			
153				
157				
159	(157, 161)			
161				
165				

14.6.2 MIMO Patch Antenna Model

The following is the RFS4011 MIMO patch antenna model for 5 GHz, its peak gain is 5dBi:

Motorola Part Number
ML-2452-PTA3M3-036

14.6.2.1 MIMO Patch Antenna Maximum Conducted Transmit Power Settings

The following is a transmit power table (EU domain) per MIMO patch antenna in the 5 GHz band:

20 MHZ CHANNEL	40 MHZ CHANNEL	LEGACY OFDM RATES (6,9,12,18,24,36,48,54 MBPS)	802.11n HT20 RATES (MCS 0 MCS 15)	802.11n HT40 RATES (MCS 0 MCS 15)
36		8.5	8.5	
38	(36,40)			9.5
40		8.5	8.5	
42		8.5	8.5	
44		8.5	8.5	
46	(44,48)			10.0
48		9.0	9.0	
52				
54	(52,56)			
56				
60				
62	(60,64)			
64				
100				
102	(100,104)			
104				
108				
112				
110	(108,112)			
116				
118	(116,120)			
120				
124				
126	(124,128)			
128				

20 MHZ CHANNEL	40 MHZ CHANNEL	LEGACY OFDM RATES (6,9,12,18,24,36,48,54 MBPS)	802.11n HT20 RATES (MCS 0 MCS 15)	802.11n HT40 RATES (MCS 0 MCS 15)
132				
134	(132,136)			
136				
140				
149				
151	(149,153)			
153				
157				
159	(157,161)			
161				
165				

14.6.3 Dipole Model

The following is the RFS4011 dipole antenna model for 5 GHz, its peak gain is 4.6 dBi:

Motorola Part Number
ML-2452-HPA5-036

14.6.3.1 Dipole Antenna Maximum Conducted Transmit Power Settings

The following is a transmit power table (EU domain) per dipole antenna in the 5 GHz band:

20 MHZ CHANNEL	40 MHZ CHANNEL	LEGACY OFDM RATES (6,9,12,18,24,36,48,54 MBPS)	802.11n HT20 RATES (MCS 0 MCS 15)	802.11n HT40 RATES (MCS 0 MCS 15)
36		10.0	10.0	
38	(36, 40)			11.0
40		10.0	10.0	
42		10.0	10.0	
44		10.5	10.5	
46	(44, 48)			12.5
48		10.5	10.5	
52				
54	(52, 56)			
56				
60				
62	(60, 64)			
64				
100				
102	(100, 104)			
104				
108				
112				
110	(108, 112)			
116				
118	(116, 120)			
120				
124				
126	(124, 128)			
128				

20 MHZ CHANNEL	40 MHZ CHANNEL	LEGACY OFDM RATES (6,9,12,18,24,36,48,54 MBPS)	802.11n HT20 RATES (MCS 0 MCS 15)	802.11n HT40 RATES (MCS 0 MCS 15)
132				
134	(132, 136)			
136				
140				
149				
151	(149, 153)			
153				
157				
159	(157, 161)			
161				
165				

14.6.4 High-Gain Antenna Model

The following is the RFS4011 high-gain antenna model for 5 GHz, its peak gain is 6.3 - 10dBi:

Motorola Part Number
ML-2452-PNA7-01R

14.6.4.1 High-Gain Antenna Transmit Power Settings

The following is a transmit power table (EU domain) per high-gain antenna in the 5 GHz band:

20 MHZ CHANNEL	40 MHZ CHANNEL	LEGACY OFDM RATES (6,9,12,18,24,36,48,54 MBPS)	802.11n HT20 RATES (MCS 0 MCS 15)	802.11n HT40 RATES (MCS 0 MCS 15)
36		8.5	8.5	
38	(36, 40)			9.5
40		8.5	8.5	
42		8.5	8.5	
44		8.5	8.5	
46	(44, 48)			10.0
48		9.0	9.0	
52				
54	(52, 56)			
56				
60				
62	(60, 64)			
64				
100				
102	(100, 104)			
104				
108				
112				
110	(108, 112)			
116				
118	(116, 120)			
120				
124				
126	(124, 128)			
128				

20 MHZ CHANNEL	40 MHZ CHANNEL	LEGACY OFDM RATES (6,9,12,18,24,36,48,54 MBPS)	802.11n HT20 RATES (MCS 0 MCS 15)	802.11n HT40 RATES (MCS 0 MCS 15)
132				
134	(132, 136)			
136				
140				
149				
151	(149, 153)			
153				
157				
159	(157, 161)			
161				
165				

14.7 Japan Regulatory Domain 2.4 GHz Band

14.7.1 Facade Antenna Model

The following is the RFS4011 facade antenna model for 2.4 GHz, the peak gain is 2.1dBi:

Motorola Part Number
ML-2452-PTA4M3X3-1

14.7.1.1 Facade Antenna Maximum Conducted Transmit Power Settings

The following is a transmit power table (Japanese domain) per facade antenna in the 2.4 GHz band:

20 MHZ CHANNEL	40 MHZ CHANNEL	LEGACY DSSS RATES (1, 2, 5.5, 11 MBPS)	LEGACY OFDM RATES (6,9,12,18,24,36, 48,54 MBPS)	802.11n HT20 RATES (MCS 0 MCS 15)	802.11n HT40 RATES (MCS 0 MCS15)
1		10.5	12.0	12.0	
2		10.5	11.5	11.5	
3	(1, 5)	10.5	11.5	11.5	13.5
4	(2, 6)	10.5	11.5	11.5	13.0
5	(3, 7)	10.5	11.5	11.5	13.0
6	(4, 8)	10.5	11.5	11.5	13.0
7	(5, 9)	10.5	11.5	11.5	13.0
8	(6, 10)	10.5	11.5	11.5	13.0
9	(7, 11)	10.5	11.5	11.5	13.0
10	(8, 10)	10.5	11.5	11.5	13.0
11	(9, 13)	10.5	11.5	11.5	13.0
12		10.5	11.5	11.5	
13		10.5	12.0	12.0	
14		12.5			

14.7.2 MIMO Patch Antenna Model

The following is the RFS4011 MIMO patch antenna model for 2.4 GHz, its peak gain is 3.5dBi:

Motorola Part Number
ML-2452-PTA3M3-036

14.7.2.1 MIMO Patch Antenna Maximum Conducted Transmit Power Settings

The following is a transmit power table (Japanese domain) per MIMO patch antenna in the 2.4 GHz band:

20 MHZ CHANNEL	40 MHZ CHANNEL	LEGACY DSSS RATES (1, 2, 5.5, 11 MBPS)	LEGACY OFDM RATES (6,9,12,18,24,36, 48,54 MBPS)	802.11n HT20 RATES (MCS 0 MCS 15)	802.11n HT40 RATES (MCS 0 MCS15)
1		10.5	12.0	12.0	
2		10.5	11.5	11.5	
3	(1, 5)	10.5	11.5	11.5	13.5
4	(2, 6)	10.5	11.5	11.5	13.0
5	(3, 7)	10.5	11.5	11.5	13.0
6	(4, 8)	10.5	11.5	11.5	13.0
7	(5, 9)	10.5	11.5	11.5	13.0
8	(6, 10)	10.5	11.5	11.5	13.0
9	(7, 11)	10.5	11.5	11.5	13.0
10	(8, 10)	10.5	11.5	11.5	13.0
11	(9, 13)	10.5	11.5	11.5	13.0
12		10.5	11.5	11.5	
13		10.5	12.0	12.0	
14		12.5			

14.7.3 Dipole Antenna Model

The following is the RFS4011 dipole antenna model for 2.4 GHz, its peak gain is 3.1dBi:

Motorola Part Number
ML-2452-HPA5-036

14.7.3.1 Dipole Antenna Maximum Conducted Transmit Power Settings

The following is a transmit power table (Japanese domain) per dipole antenna in the 2.4 GHz band:

20 MHZ CHANNEL	40 MHZ CHANNEL	LEGACY DSSS RATES (1, 2, 5.5, 11 MBPS)	LEGACY OFDM RATES (6,9,12,18,24,36, 48,54 MBPS)	802.11n HT20 RATES (MCS 0 MCS 15)	802.11n HT40 RATES (MCS 0 MCS15)
1		12.5	14.0	14.0	
2		12.0	13.5	13.5	
3	(1, 5)	12.0	13.5	13.5	15.0
4	(2, 6)	12.0	13.5	13.5	15.0
5	(3, 7)	12.0	13.5	13.5	15.0
6	(4, 8)	12.0	13.5	13.5	15.0
7	(5, 9)	12.0	13.5	13.5	15.0
8	(6, 10)	12.0	13.5	13.5	15.0
9	(7, 11)	12.0	13.5	13.5	15.0
10	(8, 10)	12.0	13.5	13.5	15.0
11	(9, 13)	12.0	13.5	13.5	15.0
12		12.0	13.5	13.5	
13		12.5	14.0	14.0	
14		14.5			

14.7.4 High-Gain Antenna Model

The following is the RFS4011 high-gain antenna model for 2.4 GHz, its peak gain is 7.5dBi:

Motorola Part Number
ML-2452-PNA7-01R

14.7.4.1 High-Gain Antenna Maximum Conducted Transmit Power Settings

The following is a transmit power table (Japanese domain) per high-gain antenna in the 2.4 GHz band:

20 MHZ CHANNEL	40 MHZ CHANNEL	LEGACY DSSS RATES (1, 2, 5.5, 11 MBPS)	LEGACY OFDM RATES (6,9,12,18,24,36, 48,54 MBPS)	802.11n HT20 RATES (MCS 0 MCS 15)	802.11n HT40 RATES (MCS0 MCS15)
1		8.0	9.0	9.0	
2		8.0	9.0	9.0	
3	(1, 5)	8.0	9.0	9.0	14.5
4	(2, 6)	8.0	9.0	9.0	14.0
5	(3, 7)	8.0	9.0	9.0	14.0
6	(4, 8)	8.0	9.0	9.0	14.0
7	(5, 9)	8.0	9.0	9.0	14.0
8	(6, 10)	8.0	9.0	9.0	14.0
9	(7, 11)	8.0	9.0	9.0	14.0
10	(8, 10)	8.0	9.0	9.0	14.0
11	(9, 13)	8.0	9.0	9.0	14.0
12		8.0	9.0	9.0	
13		8.0	9.5	9.5	
14		10.0			

14.8 Japan Regulatory Domain 5 GHz Band

14.8.1 Facade Antenna Model

The following is the RFS4011 facade antenna model for 5 GHz, its peak gain is 3.95dBi:

Motorola Part Number
ML-2452-PTA4M3X3-1

14.8.1.1 Facade Antenna Maximum Conducted Transmit Power Settings

The following is a transmit power table (Japanese domain) per facade antenna in the 5 GHz band:

20 MHZ CHANNEL	40 MHZ CHANNEL	LEGACY OFDM RATES (6,9,12,18,24,36,48,54 MBPS)	802.11n HT20 RATES (MCS 0 MCS 15)	802.11n HT40 RATES (MCS 0 MCS 15)
36		10.5	11.0	
38	(36, 40)			11.5
40		10.0	10.5	
42		9.5	10.0	
44		9.5	10.0	
46	(44, 48)			11.0
48		9.5	10.0	
52				
54	(52, 56)			
56				
60				
62	(60, 64)			
64				
100				
102	(100, 104)			
104				
108				
112				
110	(108, 112)			
116				
118	(116, 120)			
120				
124				

20 MHZ CHANNEL	40 MHZ CHANNEL	LEGACY OFDM RATES (6,9,12,18,24,36,48,54 MBPS)	802.11n HT20 RATES (MCS 0 MCS 15)	802.11n HT40 RATES (MCS 0 MCS 15)
126	(124, 128)			
128				
132				
134	(132, 136)			
136				
140				
149				
151	(149, 153)			
153				
157				
159	(157, 161)			
161				
165				

14.8.2 MIMO Patch Antenna Model

The following is the RFS4011 MIMO patch antenna model for 5 GHz, its peak gain is 5dBi:

Motorola Part Number
ML-2452-PTA3M3-036

14.8.2.1 MIMO Patch Antenna Maximum Conducted Transmit Power Settings

The following is a transmit power table (Japanese domain) per MIMO patch antenna in the 5 GHz band:

20 MHZ CHANNEL	40 MHZ CHANNEL	LEGACY OFDM RATES (6,9,12,18,24,36,48,54 MBPS)	802.11n HT20 RATES (MCS 0 MCS 15)	802.11n HT40 RATES (MCS 0 MCS 15)
36		9.0	9.5	
38	(36,40)			10.5
40		9.0	9.5	
42		8.5	9.0	
44		8.5	9.0	
46	(44,48)			10.5
48		8.5	9.0	
52				
54	(52,56)			
56				
60				
62	(60,64)			
64				
100				
102	(100,104)			
104				
108				
112				
110	(108,112)			
116				
118	(116,120)			
120				
124				
126	(124,128)			
128				

20 MHZ CHANNEL	40 MHZ CHANNEL	LEGACY OFDM RATES (6,9,12,18,24,36,48,54 MBPS)	802.11n HT20 RATES (MCS 0 MCS 15)	802.11n HT40 RATES (MCS 0 MCS 15)
132				
134	(132,136)			
136				
140				
149				
151	(149,153)			
153				
157				
159	(157,161)			
161				
165				

14.8.3 Dipole Model

The following is the RFS4011 dipole antenna model for 5 GHz, its peak gain is 4.6 dBi:

Motorola Part Number
ML-2452-HPA5-036

14.8.3.1 Dipole Antenna Maximum Conducted Transmit Power Settings

The following is a transmit power table (Japanese domain) per dipole antenna in the 5 GHz band:

20 MHZ CHANNEL	40 MHZ CHANNEL	LEGACY OFDM RATES (6,9,12,18,24,36,48,54 MBPS)	802.11n HT20 RATES (MCS 0 MCS 15)	802.11n HT40 RATES (MCS 0 MCS 15)
36		10.0	10.5	
38	(36, 40)			11.0
40		9.5	10.0	
42		9.0	9.5	
44		9.0	9.5	
46	(44, 48)			10.5
48		9.0	9.5	
52				
54	(52, 56)			
56				
60				
62	(60, 64)			
64				
100				
102	(100, 104)			
104				
108				
112				
110	(108, 112)			
116				
118	(116, 120)			
120				
124				
126	(124, 128)			
128				

20 MHZ CHANNEL	40 MHZ CHANNEL	LEGACY OFDM RATES (6,9,12,18,24,36,48,54 MBPS)	802.11n HT20 RATES (MCS 0 MCS 15)	802.11n HT40 RATES (MCS 0 MCS 15)
132				
134	(132, 136)			
136				
140				
149				
151	(149, 153)			
153				
157				
159	(157, 161)			
161				
165				

14.8.4 High-Gain Antenna Model

The following is the RFS4011 high-gain antenna model for 5 GHz, its peak gain is 6.3 - 10dBi:

Motorola Part Number
ML-2452-PNA7-01R

14.8.4.1 High-Gain Antenna Transmit Power Settings

The following is a transmit power table (Japanese domain) per high-gain antenna in the 5 GHz band:

20 MHZ CHANNEL	40 MHZ CHANNEL	LEGACY OFDM RATES (6,9,12,18,24,36,48,54 MBPS)	802.11n HT20 RATES (MCS 0 MCS 15)	802.11n HT40 RATES (MCS 0 MCS 15)
36		8.0	8.5	
38	(36, 40)			9.5
40		8.0	8.5	
42		7.5	8.0	
44		7.5	8.0	
46	(44, 48)			9.5
48		7.5	0.0	
52				
54	(52, 56)			
56				
60				
62	(60, 64)			
64				
100				
102	(100, 104)			
104				
108				
112				
110	(108, 112)			
116				
118	(116, 120)			
120				
124				
126	(124, 128)			
128				

20 MHZ CHANNEL	40 MHZ CHANNEL	LEGACY OFDM RATES (6,9,12,18,24,36,48,54 MBPS)	802.11n HT20 RATES (MCS 0 MCS 15)	802.11n HT40 RATES (MCS 0 MCS 15)
132				
134	(132, 136)			
136				
140				
149				
151	(149, 153)			
153				
157				
159	(157, 161)			
161				
165				

15

AP-6511 Regulatory Domains

The AP-6511 model Access Point contains two internal (embedded) dual-band antennas supporting both the 802.11bgn (2.4 GHz) and 802.11an (5.0 GHz) bands. No customer assembly or antenna orientation is required.

The AP-6511 radio can transmit on one or two antennas depending on the operating modes. The radio can receive on one or two antennas as well. The data rates supported are different in each case.

- 2.4 GHz Internal Antenna Peak Gain - 2dBi
- 5 GHz Internal Antenna Peak Gain - 4.5dBi

15.1 US Regulatory Domain 2.4 GHz Band

The following is a transmit power table (US domain) per antenna in the 2.4 GHz band:

20 MHZ CHANNEL	40 MHZ CHANNEL	LEGACY DSSS RATES (1, 2, 5.5, 11 MBPS)	LEGACY OFDM RATES (6,9,12,18,24,36, 48,54 MBPS)	802.11n HT20 RATES (MCS 0 MCS 15)	802.11n HT40 RATES (MCS 0 MCS15)
1		23	17	18	
2		24	18	18	
3	(1, 5)	24	18	18	14
4	(2, 6)	24	18	18	16
5	(3, 7)	24	18	18	17
6	(4, 8)	24	18	18	16
7	(5, 9)	24	18	18	16
8	(6, 10)	24	18	18	17
9	(7, 11)	24	18	18	15
10		24	18	18	
11		23	18	17	

15.2 US Regulatory Domain 5 GHz Band

The following is a transmit power table (US domain) per antenna in the 5 GHz band:

20 MHZ CHANNEL	40 MHZ CHANNEL	LEGACY OFDM RATES (6,9,12,18,24,36,48,54 MBPS)	802.11n HT20 RATES (MCS 0 MCS 15)	802.11n HT40 RATES (MCS 0 MCS 15)
36		13	14	
38	(36, 40)	13	14	14
40		13	14	
42		13	14	
44		13	14	
46	(44, 48)	13	14	14
48		13	14	
52		20	20	
54	(52, 56)	20	20	21
56		20	20	
60		20	20	
62	(60, 64)	20	20	13
64		18	20	
100		20	20	
102	(100, 104)	20	20	21
104		20	20	
108		20	20	
112		20	20	
110	(108, 112)	20	20	21
116		20	20	
118	(116, 120)	20	20	21
120		20	20	
124		20	20	
126	(124, 128)	20	20	21
128		20	20	
132		20	20	
134	(132, 136)	20	20	21
136		20	20	
140		20	20	
149		20	20	

20 MHZ CHANNEL	40 MHZ CHANNEL	LEGACY OFDM RATES (6,9,12,18,24,36,48,54 MBPS)	802.11n HT20 RATES (MCS 0 MCS 15)	802.11n HT40 RATES (MCS 0 MCS 15)
151	(149, 153)	20	20	21
153		20	20	
157		20	20	
159	(157, 161)	20	20	21
161		20	20	
165		20	20	

15.3 EU Regulatory Domain 2.4 GHz Band

The following is a transmit power table (EU domain) per antenna in the 2.4 GHz band:

20 MHZ CHANNEL	40 MHZ CHANNEL	LEGACY DSSS RATES (1, 2, 5.5, 11 MBPS)	LEGACY OFDM RATES (6,9,12,18,24,36, 48,54 MBPS)	802.11n HT20 RATES (MCS 0 MCS 15)	802.11n HT40 RATES (MCS 0 MCS15)
1		15	15	15	
2		15	15	15	
3	(1, 5)	15	15	15	15
4	(2, 6)	15	15	15	15
5	(3, 7)	15	15	15	15
6	(4, 8)	15	15	15	15
7	(5, 9)	15	15	15	15
8	(6, 10)	15	15	15	15
9	(7, 11)	15	15	15	15
10	(8, 12)	15	15	15	15
11	(9, 13)	15	15	15	15
12		15	15	15	
13		15	15	15	
14					

15.4 EU Regulatory Domain 5 GHz Band

The following is a transmit power table (EU domain) per antenna in the 5 GHz band:

20 MHZ CHANNEL	40 MHZ CHANNEL	LEGACY OFDM RATES (6,9,12,18,24,36,48,54 MBPS)	802.11n HT20 RATES (MCS 0 MCS 15)	802.11n HT40 RATES (MCS 0 MCS 15)
36		16	16	
38	(36, 40)	16	16	16
40		16	16	
42		16	16	
44		16	16	
46	(44, 48)	16	16	16
48		16	16	
52		16	16	
54	(52, 56)	16	16	16
56		16	16	
60		16	16	
62	(60, 64)	16	16	16
64		16	16	
100		20	20	
102	(100, 104)	20	20	20
104		20	20	
108		20	20	
112		20	20	
110	(108, 112)	20	20	20
116		20	20	
118	(116, 120)	20	20	20
120		20	20	
124		20	20	
126	(124, 128)	20	20	20
128		20	20	
132		20	20	
134	(132, 136)	20	20	20
136		20	20	
140		20	20	
149		20	20	

20 MHZ CHANNEL	40 MHZ CHANNEL	LEGACY OFDM RATES (6,9,12,18,24,36,48,54 MBPS)	802.11n HT20 RATES (MCS 0 MCS 15)	802.11n HT40 RATES (MCS 0 MCS 15)
151	(149, 153)	20	20	20
153		20	20	
157		20	20	
159	(157, 161)	20	20	20
161		20	20	
165		20	20	

15.5 Japan Regulatory Domain 2.4 GHz Band

The following is a transmit power table (Japanese domain) per antenna in the 2.4 GHz band:

20 MHZ CHANNEL	40 MHZ CHANNEL	LEGACY DSSS RATES (1, 2, 5.5, 11 MBPS)	LEGACY OFDM RATES (6,9,12,18,24,36, 48,54 MBPS)	802.11n HT20 RATES (MCS 0 MCS 15)	802.11n HT40 RATES (MCS 0 MCS15)
1		12	12	14	
2		12	12	14	
3	(1, 5)	12	12	14	11
4	(2, 6)	12	12	14	11
5	(3, 7)	12	12	14	11
6	(4, 8)	12	12	14	11
7	(5, 9)	12	12	14	11
8	(6, 10)	12	12	14	11
9	(7, 11)	12	12	14	11
10	(8, 12)	12	12	14	11
11	(9, 13)	12	12	14	11
12		12	12	14	
13		12	12	14	
14		14			

15.6 Japan Regulatory Domain 5 GHz Band

The following is a transmit power table (Japanese domain) per antenna in the 5 GHz band:

20 MHZ CHANNEL	40 MHZ CHANNEL	LEGACY OFDM RATES (6,9,12,18,24,36,48,54 MBPS)	802.11n HT20 RATES (MCS 0 MCS 15)	802.11n HT40 RATES (MCS 0 MCS 15)
36		7	9	
38	(36, 40)	7	9	10
40		7	9	
42		7	9	
44		7	9	
46	(44, 48)	7	9	10
48		7	9	
52		7	9	
54	(52, 56)	7	9	10
56		7	9	
60		7	9	
62	(60, 64)	7	9	10
64		7	9	
100		11	12	
102	(100, 104)	11	12	11
104		11	12	
108		11	12	
112		11	12	
110	(108, 112)	11	12	11
116		11	12	
118	(116, 120)	11	12	11
120		11	12	
124		11	12	
126	(124, 128)	11	12	11
128		11	12	
132		11	12	
134	(132, 136)	11	12	11
136		11	12	
140		11	12	
149				

20 MHZ CHANNEL	40 MHZ CHANNEL	LEGACY OFDM RATES (6,9,12,18,24,36,48,54 MBPS)	802.11n HT20 RATES (MCS 0 MCS 15)	802.11n HT40 RATES (MCS 0 MCS 15)
151	(149, 153)			
153				
157				
159	(157, 161)			
161				
165				

16

AP-621 and AP-6521 Regulatory Domains

This chapter describes standard and high power transmission capabilities for AP-621 and AP-6521 access points in both the 2.4 and 5GHz radio bands. The information is provided for the US, EU and Japanese regulatory domains. AP-621 and AP-6521 access points support 802.11a/b/g/n in both standard and high power SKUs.

16.1 AP-621 (Standard Power) US Regulatory Domain 2.4GHz Band

The following are standard power transmit tables (US domain) per listed antenna in the 2.4GHz band:

16.1.1 Internal Antenna Model

The following is an AP-621 standard transmit power table (US domain) per Internal antenna in the 2.4GHz band:

20 MHZ CHANNEL	40 MHZ CHANNEL	LEGACY DSSS RATES (1, 2, 5.5, 11 MBPS)	LEGACY OFDM RATES (6,9,12,18,24,36, 48,54 MBPS)	802.11n HT20 RATES (MCS 0 MCS 15)	802.11n HT40 RATES (MCS 0 MCS15)
1		19	14	14	
2		19	15	15	
3	(1, 5)	19	15	15	10
4	(2, 6)	19	15	15	12
5	(3, 7)	19	15	15	14
6	(4, 8)	23	15	15	14
7	(5, 9)	21	15	15	14
8	(6, 10)	21	15	15	14
9	(7, 11)	21	15	15	14
10	(8, 12)	21	15	15	
11	(9, 13)	21	15	15	

Internal antenna, peak gain = 3dBi

16.1.2 Dipole Antenna Model

The following is an AP-621 standard transmit power table (US domain) per Dipole antenna in the 2.4GHz band:

20 MHZ CHANNEL	40 MHZ CHANNEL	LEGACY DSSS RATES (1, 2, 5.5, 11 MBPS)	LEGACY OFDM RATES (6,9,12,18,24,36, 48,54 MBPS)	802.11n HT20 RATES (MCS 0 MCS 15)	802.11n HT40 RATES (MCS 0 MCS15)
1		20	16	12	
2		20	16	15	
3	(1, 5)	23	16	15	9
4	(2, 6)	23	16	15	11
5	(3, 7)	23	16	15	12
6	(4, 8)	23	16	15	15
7	(5, 9)	23	16	15	15
8	(6, 10)	23	16	15	15
9	(7, 11)	23	16	15	12
10	(8, 12)	23	14	15	12
11	(9, 13)	23	14	15	12

Dipole antenna, peak gain = 4.6dBi

16.1.3 Panel Antenna Model

The following is an AP-621 standard transmit power table (US domain) per Panel antenna in the 2.4GHz band:

20 MHZ CHANNEL	40 MHZ CHANNEL	LEGACY DSSS RATES (1, 2, 5.5, 11 MBPS)	LEGACY OFDM RATES (6,9,12,18,24,36, 48,54 MBPS)	802.11n HT20 RATES (MCS 0 MCS 15)	802.11n HT40 RATES (MCS 0 MCS15)
1		19	12	12	
2		19	12	12	
3	(1, 5)	24	18	18	6
4	(2, 6)	24	18	18	10
5	(3, 7)	24	18	18	13
6	(4, 8)	24	18	18	14
7	(5, 9)	24	18	18	14
8	(6, 10)	24	18	18	14
9	(7, 11)	24	18	18	12
10	(8, 12)	23	14	14	11
11	(9, 13)	22	14	14	6

Panel antenna, peak gain = 4.5dBi

16.1.4 Patch Antenna Model

The following is an AP-621 standard transmit power table (US domain) per Patch antenna in the 2.4GHz band:

20 MHZ CHANNEL	40 MHZ CHANNEL	LEGACY DSSS RATES (1, 2, 5.5, 11 MBPS)	LEGACY OFDM RATES (6,9,12,18,24,36, 48,54 MBPS)	802.11n HT20 RATES (MCS 0 MCS 15)	802.11n HT40 RATES (MCS 0 MCS15)
1		21	16	14	
2		22	16	16	
3	(1, 5)	24	16	16	10
4	(2, 6)	24	16	16	11
5	(3, 7)	24	16	16	14
6	(4, 8)	24	16	16	14
7	(5, 9)	24	16	16	14
8	(6, 10)	24	16	16	14
9	(7, 11)	24	16	16	14
10	(8, 12)	19	16	16	12
11	(9, 13)	18	13	13	9

Patch antenna, peak gain = 5dBi

16.2 AP-621 (Standard Power) US Regulatory Domain 5GHz Band

The following are standard power transmit tables (US domain) per listed antenna in the 5GHz band:

16.2.1 Internal Dipole Antenna Maximum Conducted Transmit Power Settings

The following is an AP-621 standard transmit power table (US domain) per Internal Dipole antenna in the 5GHz band:

20 MHZ CHANNEL	40 MHZ CHANNEL	LEGACY OFDM RATES (6,9,12,18,24,36,48,54 MBPS)	802.11n HT20 RATES (MCS 0 MCS 15)	802.11n HT40 RATES (MCS 0 MCS 15)
36		12	14	
38	(36, 40)	12	14	14
40		12	14	
42		12	14	
44		12	14	
46	(44, 48)	12	14	14
48		12	14	
52		20	20	
54	(52, 56)	20	20	20
56		20	20	
60		20	20	
62	(60, 64)	20	20	20
64		20	20	
100		15	15	
102	(100, 104)	15	15	11
104		20	20	
108		20	20	
112		20	20	
110	(108, 112)	20	20	20
116		20	20	
118	(116, 120)	20	20	20
120		20	20	
124		20	20	
126	(124, 128)	20	20	20
128		20	20	
132		20	20	
134	(132, 136)	20	14	15
136		20	20	

20 MHZ CHANNEL	40 MHZ CHANNEL	LEGACY OFDM RATES (6,9,12,18,24,36,48,54 MBPS)	802.11n HT20 RATES (MCS 0 MCS 15)	802.11n HT40 RATES (MCS 0 MCS 15)
140		14	14	
149		20	20	
151	(149, 153)	20	20	20
153		20	16	
157		20	20	
159	(157, 161)	20	20	20
161		20	20	

Internal Dipole antenna with peak gain = 6dBi

16.2.2 External Dipole Antenna Maximum Conducted Transmit Power Settings

The following is an AP-621 standard transmit power table (US domain) per External Dipole antenna in the 5GHz band:

20 MHZ CHANNEL	40 MHZ CHANNEL	LEGACY OFDM RATES (6,9,12,18,24,36,48,54 MBPS)	802.11n HT20 RATES (MCS 0 MCS 15)	802.11n HT40 RATES (MCS 0 MCS 15)
36		11	12	
38	(36, 40)	11	12	12
40		11	12	
42		11	12	
44		11	12	
46	(44, 48)	11	12	12
48		11	12	
52		20	18	
54	(52, 56)	20	20	14
56		20	20	
60		20	20	
62	(60, 64)	20	20	14
64		17	18	
100		12	12	
102	(100, 104)	15	15	9
104		20	20	
108		20	20	
112		20	20	
110	(108, 112)	20	20	19
116		20	20	
118	(116, 120)	20	20	19
120		20	20	
124		20	20	
126	(124, 128)	20	20	20
128		20	20	
132		20	20	
134	(132, 136)	15	15	15
136		20	20	
140		14	13	
149		20	20	
151	(149, 153)	20	20	20

20 MHZ CHANNEL	40 MHZ CHANNEL	LEGACY OFDM RATES (6,9,12,18,24,36,48,54 MBPS)	802.11n HT20 RATES (MCS 0 MCS 15)	802.11n HT40 RATES (MCS 0 MCS 15)
153		20	20	
157		20	20	
159	(157, 161)	20	20	20
161		20	20	

External Dipole antenna with peak gain = 5dBi

16.2.3 External Panel Antenna Maximum Conducted Transmit Power Settings

The following is an AP-621 standard transmit power table (US domain) per External Panel antenna in the 5GHz band:

20 MHZ CHANNEL	40 MHZ CHANNEL	LEGACY OFDM RATES (6,9,12,18,24,36,48,54 MBPS)	802.11n HT20 RATES (MCS 0 MCS 15)	802.11n HT40 RATES (MCS 0 MCS 15)
36		11	12	
38	(36, 40)	11	12	12
40		11	12	
42		11	12	
44		11	12	
46	(44, 48)	11	12	12
48		11	12	
52		20	16	
54	(52, 56)	20	20	14
56		22	20	
60		20	18	
62	(60, 64)	20	20	13
64		17	19	
100		12	18	
102	(100, 104)	20	20	9
104		20	20	
108		20	20	
112		20	20	
110	(108, 112)	20	11	16
116		17	19	
118	(116, 120)	20	20	20
120		20	20	
124		20	20	
126	(124, 128)	20	20	20
128		20	20	
132		20	20	
134	(132, 136)	20	20	14
136		20	20	
140		15	13	
149		20	20	
151	(149, 153)	20	20	20

20 MHZ CHANNEL	40 MHZ CHANNEL	LEGACY OFDM RATES (6,9,12,18,24,36,48,54 MBPS)	802.11n HT20 RATES (MCS 0 MCS 15)	802.11n HT40 RATES (MCS 0 MCS 15)
153		20	20	
157		20	20	
159	(157, 161)	20	20	20
161		20	20	

External Panel antenna with peak gain = 5dBi

16.2.4 External Patch Antenna Maximum Conducted Transmit Power Settings

The following is an AP-621 standard transmit power table (US domain) per External Patch antenna in the 5GHz band:

20 MHZ CHANNEL	40 MHZ CHANNEL	LEGACY OFDM RATES (6,9,12,18,24,36,48,54 MBPS)	802.11n HT20 RATES (MCS 0 MCS 15)	802.11n HT40 RATES (MCS 0 MCS 15)
36		11	12	
38	(36, 40)	11	12	12
40		11	12	
42		11	12	
44		11	12	
46	(44, 48)	11	12	12
48		12	12	
52		18	17	
54	(52, 56)	20	20	15
56		20	20	
60		17	17	
62	(60, 64)	20	20	12
64		18	16	
100		14	13	
102	(100, 104)	20	20	8
104		20	20	
108		20	20	
112		20	20	
110	(108, 112)	20	11	20
116		20	21	
118	(116, 120)	20	20	20
120		20	20	
124		20	20	
126	(124, 128)	20	20	20
128		20	20	
132		20	20	
134	(132, 136)	20	20	15
136		20	20	
140		12	12	
149		20	20	

20 MHZ CHANNEL	40 MHZ CHANNEL	LEGACY OFDM RATES (6,9,12,18,24,36,48,54 MBPS)	802.11n HT20 RATES (MCS 0 MCS 15)	802.11n HT40 RATES (MCS 0 MCS 15)
151	(149, 153)	20	20	20
153		20	20	
157		20	20	
159	(157, 161)	20	20	20
161		20	20	

External Patch antenna with peak gain = 9dBi

16.3 AP-6521 (High Power) US Regulatory Domain 2.4GHz Band

The following are high power transmit tables (US domain) per listed antenna in the 2.4GHz band:

16.3.1 Internal Antenna Model

The following is an AP-6521 high transmit power table (US domain) per Internal antenna in the 2.4GHz band:

20 MHZ CHANNEL	40 MHZ CHANNEL	LEGACY DSSS RATES (1, 2, 5.5, 11 MBPS)	LEGACY OFDM RATES (6,9,12,18,24,36, 48,54 MBPS)	802.11n HT20 RATES (MCS 0 MCS 15)	802.11n HT40 RATES (MCS 0 MCS15)
1		19	14	14	
2		19	15	15	
3	(1, 5)	19	15	15	10
4	(2, 6)	19	15	15	12
5	(3, 7)	19	15	15	14
6	(4, 8)	23	15	15	14
7	(5, 9)	21	15	15	14
8	(6, 10)	21	15	15	14
9	(7, 11)	21	15	15	14
10	(8, 12)	21	15	15	
11	(9, 13)	21	15	15	

Internal antenna, peak gain = 3dBi

16.3.2 Dipole Antenna Model

The following is an AP-6521 high transmit power table (US domain) per Dipole antenna in the 2.4GHz band:

20 MHZ CHANNEL	40 MHZ CHANNEL	LEGACY DSSS RATES (1, 2, 5.5, 11 MBPS)	LEGACY OFDM RATES (6,9,12,18,24,36, 48,54 MBPS)	802.11n HT20 RATES (MCS 0 MCS 15)	802.11n HT40 RATES (MCS 0 MCS15)
1		21	17	13	
2		20	17	16	
3	(1, 5)	25	17	16	10
4	(2, 6)	25	17	16	12
5	(3, 7)	25	17	16	13
6	(4, 8)	25	17	16	16
7	(5, 9)	25	17	16	17
8	(6, 10)	25	17	16	16
9	(7, 11)	25	17	16	13
10	(8, 12)	23	17	16	
11	(9, 13)	22	15	16	

Dipole antenna, peak gain = 4.6dBi

16.3.3 Panel Antenna Model

The following is an AP-6521 high transmit power table (US domain) per Panel antenna in the 2.4GHz band:

20 MHZ CHANNEL	40 MHZ CHANNEL	LEGACY DSSS RATES (1, 2, 5.5, 11 MBPS)	LEGACY OFDM RATES (6,9,12,18,24,36, 48,54 MBPS)	802.11n HT20 RATES (MCS 0 MCS 15)	802.11n HT40 RATES (MCS 0 MCS15)
1		18	12	12	
2		19	12	12	
3	(1, 5)	24	18	18	6
4	(2, 6)	24	18	18	10
5	(3, 7)	24	18	18	13
6	(4, 8)	24	18	18	14
7	(5, 9)	24	18	18	14
8	(6, 10)	24	18	18	14
9	(7, 11)	24	18	18	13
10	(8, 12)	23	14	14	11
11	(9, 13)	22	14	14	6

Panel antenna, peak gain = 4.5dBi

16.3.4 Patch Antenna Model

The following is an AP-6521 high transmit power table (US domain) per Patch antenna in the 2.4GHz band:

20 MHZ CHANNEL	40 MHZ CHANNEL	LEGACY DSSS RATES (1, 2, 5.5, 11 MBPS)	LEGACY OFDM RATES (6,9,12,18,24,36, 48,54 MBPS)	802.11n HT20 RATES (MCS 0 MCS 15)	802.11n HT40 RATES (MCS 0 MCS15)
1		21	16	14	
2		22	16	16	
3	(1, 5)	24	16	16	11
4	(2, 6)	24	16	16	14
5	(3, 7)	24	16	16	14
6	(4, 8)	24	16	16	14
7	(5, 9)	24	16	16	14
8	(6, 10)	24	16	16	14
9	(7, 11)	24	16	16	14
10	(8, 12)	19	16	16	12
11	(9, 13)	18	13	13	9

Patch antenna, peak gain = 5dBi

16.4 AP-6521 (High Power) US Regulatory Domain 5GHz Band

The following are high power transmit tables (US domain) per listed antenna in the 5GHz band:

16.4.1 Internal Antenna Maximum Conducted Transmit Power Settings

The following is an AP-6521 high transmit power table (US domain) per Internal antenna in the 5GHz band:

20 MHZ CHANNEL	40 MHZ CHANNEL	LEGACY OFDM RATES (6,9,12,18,24,36,48,54 MBPS)	802.11n HT20 RATES (MCS 0 MCS 15)	802.11n HT40 RATES (MCS 0 MCS 15)
36		12	14	
38	(36, 40)	12	14	14
40		12	14	
42		12	14	
44		12	14	
46	(44, 48)	12	14	14
48		12	14	
52		20	20	
54	(52, 56)	20	20	20
56		20	20	
60		20	20	
62	(60, 64)	20	20	20
64		20	20	
100		14	14	
102	(100, 104)	15	15	10
104		20	20	
108		20	20	
112		20	20	
110	(108, 112)	20	20	20
116		20	20	
118	(116, 120)	20	20	20
120		20	20	
124		20	20	
126	(124, 128)	20	20	20
128		20	20	
132		20	20	
134	(132, 136)	20	14	14

20 MHZ CHANNEL	40 MHZ CHANNEL	LEGACY OFDM RATES (6,9,12,18,24,36,48,54 MBPS)	802.11n HT20 RATES (MCS 0 MCS 15)	802.11n HT40 RATES (MCS 0 MCS 15)
136		20	20	
140		20	13	
149		20	20	
151	(149, 153)	20	20	20
153		20	20	
157		20	20	
159	(157, 161)	20	20	20
161		20	20	
165		20	20	

Internal antenna with peak gain = 6dBi

16.4.2 External Dipole Antenna Maximum Conducted Transmit Power Settings

The following is an AP-6521 high transmit power table (US domain) per External Dipole antenna in the 5GHz band:

20 MHZ CHANNEL	40 MHZ CHANNEL	LEGACY OFDM RATES (6,9,12,18,24,36,48,54 MBPS)	802.11n HT20 RATES (MCS 0 MCS 15)	802.11n HT40 RATES (MCS 0 MCS 15)
36		11	12	
38	(36, 40)	11	12	12
40		11	12	
42		11	12	
44		11	12	
46	(44, 48)	11	12	12
48		11	12	
52		20	18	
54	(52, 56)	20	20	14
56		20	20	
60		20	20	
62	(60, 64)	20	20	14
64		17	18	
100		12	12	
102	(100, 104)	15	15	9
104		21	20	
108		21	20	
112		21	20	
110	(108, 112)	21	20	19
116		21	20	
118	(116, 120)	21	20	20
120		21	20	
124		21	20	
126	(124, 128)	21	20	20
128		21	20	
132		21	20	
134	(132, 136)	15	15	15
136		20	20	
140		13	13	
149		20	20	

20 MHZ CHANNEL	40 MHZ CHANNEL	LEGACY OFDM RATES (6,9,12,18,24,36,48,54 MBPS)	802.11n HT20 RATES (MCS 0 MCS 15)	802.11n HT40 RATES (MCS 0 MCS 15)
151	(149, 153)	20	20	20
153		20	20	
157		20	20	
159	(157, 161)	20	20	20
161		20	20	
165		20	20	

External Dipole antenna with peak gain = 5dBi

16.4.3 External Panel Antenna Maximum Conducted Transmit Power Settings

The following is an AP-6521 high transmit power table (US domain) per External Panel antenna in the 5GHz band:

20 MHZ CHANNEL	40 MHZ CHANNEL	LEGACY OFDM RATES (6,9,12,18,24,36,48,54 MBPS)	802.11n HT20 RATES (MCS 0 MCS 15)	802.11n HT40 RATES (MCS 0 MCS 15)
36		11	12	
38	(36, 40)	11	12	12
40		11	12	
42		11	12	
44		11	12	
46	(44, 48)	11	12	12
48		11	12	
52		20	16	
54	(52, 56)	20	20	14
56		20	20	
60		20	18	
62	(60, 64)	20	20	13
64		17	19	
100		12	11	
102	(100, 104)	20	20	9
104		20	20	
108		20	20	
112		20	20	
110	(108, 112)	20	11	16
116		20	19	
118	(116, 120)	20	20	20
120		20	20	
124		20	20	
126	(124, 128)	20	20	20
128		20	20	
132		20	20	
134	(132, 136)	20	20	14
136		20	20	
140		14	13	
149		20	20	

20 MHZ CHANNEL	40 MHZ CHANNEL	LEGACY OFDM RATES (6,9,12,18,24,36,48,54 MBPS)	802.11n HT20 RATES (MCS 0 MCS 15)	802.11n HT40 RATES (MCS 0 MCS 15)
151	(149, 153)	20	20	20
153		20	20	
157		20	20	
159	(157, 161)	20	20	20
161		20	20	
165		20	20	

External Panel antenna with peak gain = 5dBi

16.4.4 External Patch Antenna Maximum Conducted Transmit Power Settings

The following is an AP-6521 high transmit power table (US domain) per External Patch antenna in the 5GHz band:

20 MHZ CHANNEL	40 MHZ CHANNEL	LEGACY OFDM RATES (6,9,12,18,24,36,48,54 MBPS)	802.11n HT20 RATES (MCS 0 MCS 15)	802.11n HT40 RATES (MCS 0 MCS 15)
36		11	12	
38	(36, 40)	11	12	11
40		11	12	
42		11	12	
44		11	12	
46	(44, 48)	11	12	13
48		11	12	
52		20	16	
54	(52, 56)	20	20	15
56		20	20	
60		20	18	
62	(60, 64)	20	20	12
64		17	19	
100		12	11	
102	(100, 104)	20	20	12
104		20	20	
108		20	20	
112		20	20	
110	(108, 112)	20	20	21
116		17	20	
118	(116, 120)	20	20	21
120		20	20	
124		20	20	
126	(124, 128)	20	20	22
128		20	20	
132		20	20	
134	(132, 136)	20	20	22
136		20	20	
140		14	13	
149		20	20	

20 MHZ CHANNEL	40 MHZ CHANNEL	LEGACY OFDM RATES (6,9,12,18,24,36,48,54 MBPS)	802.11n HT20 RATES (MCS 0 MCS 15)	802.11n HT40 RATES (MCS 0 MCS 15)
151	(149, 153)	20	20	20
153		20	20	
157		20	20	
159	(157, 161)	20	20	20
161		20	20	
165		20	20	

External Patch antenna with peak gain = 9dBi

16.5 AP-621 (Standard Power) EU Regulatory Domain 2.4GHz Band

The following are standard power transmit tables (EU domain) per listed antenna in the 2.4GHz band:

16.5.1 Internal Antenna Model

The following is an AP-621 standard transmit power table (EU domain) per Internal antenna in the 2.4GHz band:

20 MHZ CHANNEL	40 MHZ CHANNEL	LEGACY DSSS RATES (1, 2, 5.5, 11 MBPS)	LEGACY OFDM RATES (6,9,12,18,24,36, 48,54 MBPS)	802.11n HT20 RATES (MCS 0 MCS 15)	802.11n HT40 RATES (MCS 0 MCS15)
1		14	14	14	
2		14	14	14	
3	(1, 5)	14	14	14	14
4	(2, 6)	14	14	14	14
5	(3, 7)	14	14	14	14
6	(4, 8)	14	14	14	14
7	(5, 9)	14	14	14	14
8	(6, 10)	14	14	14	14
9	(7, 11)	14	14	14	14
10	(8, 12)	14	14	14	14
11	(9, 13)	14	14	14	14
12		14	14	14	
13		14	14	14	
14					

Internal antenna, peak gain = 3dBi

16.5.2 Dipole Antenna Model

The following is an AP-621 standard transmit power table (EU domain) per Dipole antenna in the 2.4GHz band:

20 MHZ CHANNEL	40 MHZ CHANNEL	LEGACY DSSS RATES (1, 2, 5.5, 11 MBPS)	LEGACY OFDM RATES (6,9,12,18,24,36, 48,54 MBPS)	802.11n HT20 RATES (MCS 0 MCS 15)	802.11n HT40 RATES (MCS 0 MCS15)
1		12	12	12	
2		12	12	12	
3	(1, 5)	12	12	12	12
4	(2, 6)	12	12	12	12
5	(3, 7)	12	12	12	12
6	(4, 8)	12	12	12	12
7	(5, 9)	12	12	12	12
8	(6, 10)	12	12	12	12
9	(7, 11)	12	12	12	12
10	(8, 12)	12	12	12	12
11	(9, 13)	12	12	12	12
12		12	12	12	
13		12	12	12	
14					

Dipole antenna, peak gain = 4.6dBi

16.5.3 Panel Antenna Model

The following is an AP-621 standard transmit power table (EU domain) per Panel antenna in the 2.4GHz band:

20 MHZ CHANNEL	40 MHZ CHANNEL	LEGACY DSSS RATES (1, 2, 5.5, 11 MBPS)	LEGACY OFDM RATES (6,9,12,18,24,36, 48,54 MBPS)	802.11n HT20 RATES (MCS 0 MCS 15)	802.11n HT40 RATES (MCS 0 MCS15)
1		12	12	12	
2		12	12	12	
3	(1, 5)	12	12	12	12
4	(2, 6)	12	12	12	12
5	(3, 7)	12	12	12	12
6	(4, 8)	12	12	12	12
7	(5, 9)	12	12	12	12
8	(6, 10)	12	12	12	12
9	(7, 11)	12	12	12	12
10	(8, 12)	12	12	12	12
11	(9, 13)	12	12	12	12
12		12	12	12	
13		12	12	12	
14					

Panel antenna, peak gain = 4.5dBi

16.5.4 Patch Antenna Model

The following is an AP-621 standard transmit power table (EU domain) per Patch antenna in the 2.4GHz band:

20 MHZ CHANNEL	40 MHZ CHANNEL	LEGACY DSSS RATES (1, 2, 5.5, 11 MBPS)	LEGACY OFDM RATES (6,9,12,18,24,36, 48,54 MBPS)	802.11n HT20 RATES (MCS 0 MCS 15)	802.11n HT40 RATES (MCS 0 MCS15)
1		12	12	12	
2		12	12	12	
3	(1, 5)	12	12	12	12
4	(2, 6)	12	12	12	12
5	(3, 7)	12	12	12	12
6	(4, 8)	12	12	12	12
7	(5, 9)	12	12	12	12
8	(6, 10)	12	12	12	12
9	(7, 11)	12	12	12	12
10	(8, 12)	12	12	12	12
11	(9, 13)	12	12	12	12
12		12	12	12	
13		12	12	12	
14					

Patch antenna, peak gain = 5dBi

16.6 AP-621 (Standard Power) EU Regulatory Domain 5GHz Band

The following are standard power transmit tables (EU domain) per listed antenna in the 5GHz band:

16.6.1 External Dipole Antenna Maximum Conducted Transmit Power Settings

The following is an AP-621 standard transmit power table (EU domain) per External Dipole antenna in the 5GHz band:

20 MHZ CHANNEL	40 MHZ CHANNEL	LEGACY OFDM RATES (6,9,12,18,24,36,48,54 MBPS)	802.11n HT20 RATES (MCS 0 MCS 15)	802.11n HT40 RATES (MCS 0 MCS 15)
36		15	15	
38	(36, 40)	15	15	15
40		15	15	
42		15	15	
44		15	15	
46	(44, 48)	15	15	15
48		15	15	
52		15	15	
54	(52, 56)	15	15	15
56		15	15	
60		15	15	
62	(60, 64)	15	15	15
64		15	15	
100		20	20	
102	(100, 104)	20	20	20
104		20	20	
108		20	20	
112		20	20	
110	(108, 112)	20	20	20
116		20	20	
118	(116, 120)	20	20	20
120		20	20	
124		20	20	
126	(124, 128)	20	20	20
128		20	20	
132		20	20	
134	(132, 136)	20	20	20

20 MHZ CHANNEL	40 MHZ CHANNEL	LEGACY OFDM RATES (6,9,12,18,24,36,48,54 MBPS)	802.11n HT20 RATES (MCS 0 MCS 15)	802.11n HT40 RATES (MCS 0 MCS 15)
136		20	20	
140		20	20	
149				
151	(149, 153)			
153				
157				
159	(157, 161)			
161				

External Dipole antenna with peak gain = 5dBi

16.6.2 External Panel Antenna Maximum Conducted Transmit Power Settings

The following is an AP-621 standard transmit power table (EU domain) per External Panel antenna in the 5GHz band:

20 MHZ CHANNEL	40 MHZ CHANNEL	LEGACY OFDM RATES (6,9,12,18,24,36,48,54 MBPS)	802.11n HT20 RATES (MCS 0 MCS 15)	802.11n HT40 RATES (MCS 0 MCS 15)
36		15	15	
38	(36, 40)	15	15	15
40		15	15	
42		15	15	
44		15	15	
46	(44, 48)	15	15	15
48		15	15	
52		15	15	
54	(52, 56)	15	15	15
56		15	15	
60		15	15	
62	(60, 64)	15	15	15
64		15	15	
100		20	20	
102	(100, 104)	20	20	20
104		20	20	
108		20	20	
112		20	20	
110	(108, 112)	20	20	20
116		20	20	
118	(116, 120)	20	20	20
120		20	20	
124		20	20	
126	(124, 128)	20	20	20
128		20	20	
132		20	20	
134	(132, 136)	20	20	20
136		20	20	
140		20	20	
149				

20 MHZ CHANNEL	40 MHZ CHANNEL	LEGACY OFDM RATES (6,9,12,18,24,36,48,54 MBPS)	802.11n HT20 RATES (MCS 0 MCS 15)	802.11n HT40 RATES (MCS 0 MCS 15)
151	(149, 153)			
153				
157				
159	(157, 161)			
161				

External Panel antenna with peak gain = 5dBi

16.6.3 External Patch Antenna Maximum Conducted Transmit Power Settings

The following is an AP-621 standard transmit power table (EU domain) per External Patch antenna in the 5GHz band:

20 MHZ CHANNEL	40 MHZ CHANNEL	LEGACY OFDM RATES (6,9,12,18,24,36,48,54 MBPS)	802.11n HT20 RATES (MCS 0 MCS 15)	802.11n HT40 RATES (MCS 0 MCS 15)
36		11	11	
38	(36, 40)	11	11	11
40		11	11	
42		11	11	
44		11	11	
46	(44, 48)	11	11	11
48		11	11	
52		11	11	
54	(52, 56)	11	11	11
56		11	11	
60		11	11	
62	(60, 64)	11	11	11
64		11	11	
100		18	18	
102	(100, 104)	18	18	18
104		18	18	
108		18	18	
112		18	18	
110	(108, 112)	18	18	18
116		18	18	
118	(116, 120)	18	18	18
120		18	18	
124		18	18	
126	(124, 128)	18	18	18
128		18	18	
132		18	18	
134	(132, 136)	18	18	18
136		18	18	
140		18	18	
149				

20 MHZ CHANNEL	40 MHZ CHANNEL	LEGACY OFDM RATES (6,9,12,18,24,36,48,54 MBPS)	802.11n HT20 RATES (MCS 0 MCS 15)	802.11n HT40 RATES (MCS 0 MCS 15)
151	(149, 153)			
153				
157				
159	(157, 161)			
161				

External Patch antenna with peak gain = 9dBi

16.6.4 Internal Patch Antenna Maximum Conducted Transmit Power Settings

The following is an AP-621 standard transmit power table (EU domain) per Internal Patch antenna in the 5GHz band:

20 MHZ CHANNEL	40 MHZ CHANNEL	LEGACY OFDM RATES (6,9,12,18,24,36,48,54 MBPS)	802.11n HT20 RATES (MCS 0 MCS 15)	802.11n HT40 RATES (MCS 0 MCS 15)
36		14	14	
38	(36, 40)	14	14	14
40		14	14	
42		14	14	
44		14	14	
46	(44, 48)	14	14	14
48		14	14	
52		14	14	
54	(52, 56)	14	14	14
56		14	14	
60		14	14	
62	(60, 64)	14	14	14
64		14	14	
100		20	20	
102	(100, 104)	20	20	20
104		20	20	
108		20	20	
112		20	20	
110	(108, 112)	20	20	20
116		20	20	
118	(116, 120)	20	20	20
120		20	20	
124		20	20	
126	(124, 128)	20	20	
128		20	20	20
132		20	20	
134	(132, 136)	20	20	20
136		20	20	
140		20	20	
149				

20 MHZ CHANNEL	40 MHZ CHANNEL	LEGACY OFDM RATES (6,9,12,18,24,36,48,54 MBPS)	802.11n HT20 RATES (MCS 0 MCS 15)	802.11n HT40 RATES (MCS 0 MCS 15)
151	(149, 153)			
153				
157				
159	(157, 161)			
161				

Internal Patch antenna with peak gain = 6dBi

16.7 AP6521 (High Power) EU Regulatory Domain 2.4GHz Band

The following are high power transmit tables (EU domain) per listed antenna in the 2.4GHz band:

16.7.1 Internal Antenna Model

The following is an AP-6521 high transmit power table (EU domain) per Internal antenna in the 2.4GHz band:

20 MHZ CHANNEL	40 MHZ CHANNEL	LEGACY DSSS RATES (1, 2, 5.5, 11 MBPS)	LEGACY OFDM RATES (6,9,12,18,24,36, 48,54 MBPS)	802.11n HT20 RATES (MCS 0 MCS 15)	802.11n HT40 RATES (MCS 0 MCS15)
1		14	14	14	
2		14	14	14	
3	(1, 5)	14	14	14	14
4	(2, 6)	14	14	14	14
5	(3, 7)	14	14	14	14
6	(4, 8)	14	14	14	14
7	(5, 9)	14	14	14	14
8	(6, 10)	14	14	14	14
9	(7, 11)	14	14	14	14
10	(8, 12)	14	14	14	14
11	(9, 13)	14	14	14	14
12		14	14	14	
13		14	14	14	
14					

Internal antenna, peak gain = 3dBi

16.7.2 Dipole Antenna Model

The following is an AP-6521 high transmit power table (EU domain) per Dipole antenna in the 2.4GHz band:

20 MHZ CHANNEL	40 MHZ CHANNEL	LEGACY DSSS RATES (1, 2, 5.5, 11 MBPS)	LEGACY OFDM RATES (6,9,12,18,24,36, 48,54 MBPS)	802.11n HT20 RATES (MCS 0 MCS 15)	802.11n HT40 RATES (MCS 0 MCS15)
1		12	12	12	
2		12	12	12	
3	(1, 5)	12	12	12	12
4	(2, 6)	12	12	12	12
5	(3, 7)	12	12	12	12
6	(4, 8)	12	12	12	12
7	(5, 9)	12	12	12	12
8	(6, 10)	12	12	12	12
9	(7, 11)	12	12	12	12
10	(8, 12)	12	12	12	12
11	(9, 13)	12	12	12	12
12		12	12	12	
13		12	12	12	
14					

Dipole antenna, peak gain = 4.6dBi

16.7.3 Panel Antenna Model

The following is an AP-6521 high transmit power table (EU domain) per Panel antenna in the 2.4GHz band:

20 MHZ CHANNEL	40 MHZ CHANNEL	LEGACY DSSS RATES (1, 2, 5.5, 11 MBPS)	LEGACY OFDM RATES (6,9,12,18,24,36, 48,54 MBPS)	802.11n HT20 RATES (MCS 0 MCS 15)	802.11n HT40 RATES (MCS 0 MCS15)
1		12	12	12	
2		12	12	12	
3	(1, 5)	12	12	12	12
4	(2, 6)	12	12	12	12
5	(3, 7)	12	12	12	12
6	(4, 8)	12	12	12	12
7	(5, 9)	12	12	12	12
8	(6, 10)	12	12	12	12
9	(7, 11)	12	12	12	12
10	(8, 12)	12	12	12	12
11	(9, 13)	12	12	12	12
12		12	12	12	
13		12	12	12	
14					

Panel antenna, peak gain = 4.5dBi

16.7.4 Patch Antenna Model

The following is an AP-6521 high transmit power table (EU domain) per Patch antenna in the 2.4GHz band:

20 MHZ CHANNEL	40 MHZ CHANNEL	LEGACY DSSS RATES (1, 2, 5.5, 11 MBPS)	LEGACY OFDM RATES (6,9,12,18,24,36, 48,54 MBPS)	802.11n HT20 RATES (MCS 0 MCS 15)	802.11n HT40 RATES (MCS 0 MCS15)
1		12	12	12	
2		12	12	12	
3	(1, 5)	12	12	12	12
4	(2, 6)	12	12	12	12
5	(3, 7)	12	12	12	12
6	(4, 8)	12	12	12	12
7	(5, 9)	12	12	12	12
8	(6, 10)	12	12	12	12
9	(7, 11)	12	12	12	12
10	(8, 12)	12	12	12	12
11	(9, 13)	12	12	12	12
12		12	12	12	
13		12	12	12	
14					

Patch antenna, peak gain = 5dBi

16.8 AP-6521 (High Power) EU Regulatory Domain 5GHz Band

The following are high power transmit tables (EU domain) per listed antenna in the 5GHz band:

16.8.1 Internal Antenna Maximum Conducted Transmit Power Settings

The following is an AP-6521 high transmit power table (EU domain) per Internal antenna in the 5GHz band:

20 MHZ CHANNEL	40 MHZ CHANNEL	LEGACY OFDM RATES (6,9,12,18,24,36,48,54 MBPS)	802.11n HT20 RATES (MCS 0 MCS 15)	802.11n HT40 RATES (MCS 0 MCS 15)
36		14	14	
38	(36, 40)	14	14	14
40		14	14	
42		14	14	
44		14	14	
46	(44, 48)	14	14	14
48		14	14	
52		14	14	
54	(52, 56)	14	14	14
56		14	14	
60		14	14	
62	(60, 64)	14	14	14
64		14	14	
100		20	20	
102	(100, 104)	20	20	20
104		20	20	
108		20	20	
112		20	20	
110	(108, 112)	20	20	20
116		20	20	
118	(116, 120)	20	20	20
120		20	20	
124		20	20	
126	(124, 128)	20	20	20
128		20	20	
132		20	20	
134	(132, 136)	20	20	20

20 MHZ CHANNEL	40 MHZ CHANNEL	LEGACY OFDM RATES (6,9,12,18,24,36,48,54 MBPS)	802.11n HT20 RATES (MCS 0 MCS 15)	802.11n HT40 RATES (MCS 0 MCS 15)
136		20	20	
140		20	20	
149				
151	(149, 153)			
153				
157				
159	(157, 161)			
161				

Internal antenna with peak gain = 6dBi

16.8.2 External Dipole Antenna Maximum Conducted Transmit Power Settings

The following is an AP-6521 high transmit power table (EU domain) per External Dipole antenna in the 5GHz band:

20 MHZ CHANNEL	40 MHZ CHANNEL	LEGACY OFDM RATES (6,9,12,18,24,36,48,54 MBPS)	802.11n HT20 RATES (MCS 0 MCS 15)	802.11n HT40 RATES (MCS 0 MCS 15)
36		15	15	
38	(36, 40)	15	15	15
40		15	15	
42		15	15	
44		15	15	
46	(44, 48)	15	15	15
48		15	15	
52		15	15	
54	(52, 56)	15	15	15
56		15	15	
60		15	15	
62	(60, 64)	15	15	15
64		15	15	
100		20	20	
102	(100, 104)	20	20	20
104		20	20	
108		20	20	
112		20	20	
110	(108, 112)	20	20	20
116		20	20	
118	(116, 120)	20	20	20
120		20	20	
124		20	20	
126	(124, 128)	20	20	20
128		20	20	
132		20	20	
134	(132, 136)	20	20	20
136		20	20	
140		20	20	
149				

20 MHZ CHANNEL	40 MHZ CHANNEL	LEGACY OFDM RATES (6,9,12,18,24,36,48,54 MBPS)	802.11n HT20 RATES (MCS 0 MCS 15)	802.11n HT40 RATES (MCS 0 MCS 15)
151	(149, 153)			
153				
157				
159	(157, 161)			
161				

External Dipole antenna with peak gain = 5dBi

16.8.3 External Panel Antenna Maximum Conducted Transmit Power Settings

The following is an AP-6521 high transmit power table (EU domain) per External Panel antenna in the 5GHz band:

20 MHZ CHANNEL	40 MHZ CHANNEL	LEGACY OFDM RATES (6,9,12,18,24,36,48,54 MBPS)	802.11n HT20 RATES (MCS 0 MCS 15)	802.11n HT40 RATES (MCS 0 MCS 15)
36		15	15	
38	(36, 40)	15	15	15
40		15	15	
42		15	15	
44		15	15	
46	(44, 48)	15	15	15
48		15	15	
52		22	22	
54	(52, 56)	22	22	22
56		22	22	
60		22	22	
62	(60, 64)	22	22	22
64		22	22	
100		22	22	
102	(100, 104)	22	22	22
104		22	22	
108		22	22	
112		22	22	
110	(108, 112)	22	22	22
116		22	22	
118	(116, 120)	22	22	22
120		22	22	
124		22	22	
126	(124, 128)	22	22	22
128		22	22	
132		22	22	
134	(132, 136)	22	22	22
136		22	22	
140		22	22	
149				

20 MHZ CHANNEL	40 MHZ CHANNEL	LEGACY OFDM RATES (6,9,12,18,24,36,48,54 MBPS)	802.11n HT20 RATES (MCS 0 MCS 15)	802.11n HT40 RATES (MCS 0 MCS 15)
151	(149, 153)			
153				
157				
159	(157, 161)			
161				

External Panel antenna with peak gain = 5dBi

16.8.4 External Patch Antenna Maximum Conducted Transmit Power Settings

The following is an AP-6521 high transmit power table (EU domain) per External Patch antenna in the 5GHz band:

20 MHZ CHANNEL	40 MHZ CHANNEL	LEGACY OFDM RATES (6,9,12,18,24,36,48,54 MBPS)	802.11n HT20 RATES (MCS 0 MCS 15)	802.11n HT40 RATES (MCS 0 MCS 15)
36		17	17	
38	(36, 40)	17	17	17
40		17	17	
42		17	17	
44		17	17	
46	(44, 48)	17	17	17
48		17	17	
52		22	22	
54	(52, 56)	22	22	22
56		22	22	
60		22	22	
62	(60, 64)	22	22	22
64		22	22	
100		22	22	
102	(100, 104)	22	22	22
104		22	22	
108		22	22	
112		22	22	
110	(108, 112)	22	22	22
116		22	22	
118	(116, 120)	22	22	22
120		22	22	
124		22	22	
126	(124, 128)	22	22	22
128		22	22	
132		22	22	
134	(132, 136)	22	22	22
136		22	22	
140		22	22	
149				

20 MHZ CHANNEL	40 MHZ CHANNEL	LEGACY OFDM RATES (6,9,12,18,24,36,48,54 MBPS)	802.11n HT20 RATES (MCS 0 MCS 15)	802.11n HT40 RATES (MCS 0 MCS 15)
151	(149, 153)			
153				
157				
159	(157, 161)			
161				

External Patch antenna with peak gain = 3dBi

16.9 AP-621 (Standard Power) Japan Regulatory Domain 2.4GHz Band

The following are standard power transmit tables (Japanese domain) per listed antenna in the 2.4GHz band:

16.9.1 Dipole (Dual-Band) or Outdoor Omni Dipole Antenna Model

The following is an AP-621 standard transmit power table (Japanese domain) per dipole (dual-band) or outdoor omni dipole antenna in the 2.4GHz band:

20 MHZ CHANNEL	40 MHZ CHANNEL	LEGACY DSSS RATES (1, 2, 5.5, 11 MBPS)	LEGACY OFDM RATES (6,9,12,18,24,36, 48,54 MBPS)	802.11n HT20 RATES (MCS 0 MCS 15)	802.11n HT40 RATES (MCS 0 MCS15)
1		17	19	19	
2		17	19	19	
3	(1, 5)	17	19	19	22
4	(2, 6)	17	19	19	22
5	(3, 7)	17	19	19	22
6	(4, 8)	17	19	19	22
7	(5, 9)	17	19	19	22
8	(6, 10)	17	19	19	22
9	(7, 11)	17	19	19	22
10	(8, 12)	17	19	19	22
11	(9, 13)	17	19	19	22
12		17	19	19	
13		17	19	19	
14					

Dipole (dual-band) or outdoor omni dipole antenna with peak gain = 3dBi

16.9.2 Internal (Dual-Band) Antenna Model

The following is an AP-621 standard transmit power table (Japanese domain) per internal (dual-band) antenna in the 2.4GHz band:

20 MHZ CHANNEL	40 MHZ CHANNEL	LEGACY DSSS RATES (1, 2, 5.5, 11 MBPS)	LEGACY OFDM RATES (6,9,12,18,24,36, 48,54 MBPS)	802.11n HT20 RATES (MCS 0 MCS 15)	802.11n HT40 RATES (MCS 0 MCS15)
1		17	19	19	
2		17	19	19	
3	(1, 5)	17	19	19	22
4	(2, 6)	17	19	19	22
5	(3, 7)	17	19	19	22
6	(4, 8)	17	19	19	22
7	(5, 9)	17	19	19	22
8	(6, 10)	17	19	19	22
9	(7, 11)	17	19	19	22
10	(8, 12)	17	19	19	22
11	(9, 13)	17	19	19	22
12		17	19	19	
13		17	19	19	
14					

Internal (dual-band) antenna with peak gain = 3dBi

16.9.3 Panel Antenna Model

The following is an AP-621 standard transmit power table (Japanese domain) per panel antenna in the 2.4GHz band:

20 MHZ CHANNEL	40 MHZ CHANNEL	LEGACY DSSS RATES (1, 2, 5.5, 11 MBPS)	LEGACY OFDM RATES (6,9,12,18,24,36, 48,54 MBPS)	802.11n HT20 RATES (MCS 0 MCS 15)	802.11n HT40 RATES (MCS 0 MCS15)
1		16	17	17	
2		16	19	17	
3	(1, 5)	16	17	17	20
4	(2, 6)	16	17	17	20
5	(3, 7)	16	17	17	20
6	(4, 8)	16	17	17	20
7	(5, 9)	16	17	17	20
8	(6, 10)	16	17	17	20
9	(7, 11)	16	17	17	20
10	(8, 12)	16	17	17	20
11	(9, 13)	16	17	17	20
12		16	17	17	
13		16	17	17	
14					

Panel antenna with peak gain = 4.5dBi

16.9.4 Patch Antenna Model

The following is an AP-621 standard transmit power table (Japanese domain) per patch antenna in the 2.4GHz band:

20 MHZ CHANNEL	40 MHZ CHANNEL	LEGACY DSSS RATES (1, 2, 5.5, 11 MBPS)	LEGACY OFDM RATES (6,9,12,18,24,36, 48,54 MBPS)	802.11n HT20 RATES (MCS 0 MCS 15)	802.11n HT40 RATES (MCS 0 MCS15)
1		16	17	17	
2		16	19	17	
3	(1, 5)	16	17	17	20
4	(2, 6)	16	17	17	20
5	(3, 7)	16	17	17	20
6	(4, 8)	16	17	17	20
7	(5, 9)	16	17	17	20
8	(6, 10)	16	17	17	20
9	(7, 11)	16	17	17	20
10	(8, 12)	16	17	17	20
11	(9, 13)	16	17	17	20
12		16	17	17	
13		16	17	17	
14					

Patch antenna with peak gain = 5dBi

16.10 AP-621 (Standard Power) Japan Regulatory Domain 5GHz Band

The following are AP-621 standard power tables (Japanese domain) per listed antenna in the 5GHz band:

16.10.1 Dipole (Dual-Band) or Outdoor Omni Dipole Antenna Model Maximum Conducted Transmit Power Settings

The following is an AP-621 standard transmit power table (Japanese domain) per dipole (dual-band) or outdoor omni dipole antenna in the 5GHz band:

20 MHZ CHANNEL	40 MHZ CHANNEL	LEGACY OFDM RATES (6,9,12,18,24,36,48,54 MBPS)	802.11n HT20 RATES (MCS 0 MCS 15)	802.11n HT40 RATES (MCS 0 MCS 15)
36		10.0	12.5	
38	(36, 40)	12.5	12.5	12.5
40		12.5	12.5	
42		12.5	12.5	
44		12.5	12.5	
46	(44, 48)	12.5	12.5	12.5
48		12.5	12.5	
52		12.5	12.5	
54	(52, 56)	12.5	12.5	12.5
56		12.5	12.5	
60		12.5	12.5	
62	(60, 64)	12.5	12.5	12.5
64		12.5	12.5	
100		18.0	18.0	
102	(100, 104)	18.0	18.0	18.0
104		18.0	18.0	
108		18.0	18.0	
112		18.0	18.0	
110	(108, 112)	18.0	18.0	18.0
116		18.0	18.0	
118	(116, 120)	18.0	18.0	18.0
120		18.0	18.0	
124		18.0	18.0	
126	(124, 128)	18.0	18.0	18.0
128		18.0	18.0	
132		18.0	18.0	

20 MHZ CHANNEL	40 MHZ CHANNEL	LEGACY OFDM RATES (6,9,12,18,24,36,48,54 MBPS)	802.11n HT20 RATES (MCS 0 MCS 15)	802.11n HT40 RATES (MCS 0 MCS 15)
134	(132, 136)	18.0	18.0	18.0
136		18.0	18.0	
140		18.0	18.0	
149				
151	(149, 153)			
153				
157				
159	(157, 161)			
161				

Dipole (dual-band) or outdoor omni dipole antenna with peak gain = 5dBi

16.10.2 Internal (Dual-Band) Antenna Model Maximum Conducted Transmit Power Settings

The following is an AP-621 standard transmit power table (Japanese domain) per internal (dual-band) antenna in the 5GHz band:

20 MHZ CHANNEL	40 MHZ CHANNEL	LEGACY OFDM RATES (6,9,12,18,24,36,48,54 MBPS)	802.11n HT20 RATES (MCS 0 MCS 15)	802.11n HT40 RATES (MCS 0 MCS 15)
36		11.5	11.5	
38	(36, 40)	11.5	11.5	11.5
40		11.5	11.5	
42		11.5	11.5	
44		11.5	11.5	
46	(44, 48)	11.5	11.5	11.5
48		11.5	11.5	
52		11.5	11.5	
54	(52, 56)	11.5	11.5	11.5
56		11.5	11.5	
60		11.5	11.5	
62	(60, 64)	11.5	11.5	11.5
64		11.5	11.5	
100		17.0	17.0	
102	(100, 104)	17.0	17.0	17.0
104		17.0	17.0	
108		17.0	17.0	
112		17.0	17.0	
110	(108, 112)	17.0	17.0	17.0
116		17.0	17.0	
118	(116, 120)	17.0	17.0	18.0
120		17.0	17.0	
124		17.0	17.0	
126	(124, 128)	17.0	17.0	17.0
128		17.0	17.0	
132		17.0	17.0	
134	(132, 136)	17.0	17.0	17.0
136		17.0	17.0	
140		17.0	17.0	

20 MHZ CHANNEL	40 MHZ CHANNEL	LEGACY OFDM RATES (6,9,12,18,24,36,48,54 MBPS)	802.11n HT20 RATES (MCS 0 MCS 15)	802.11n HT40 RATES (MCS 0 MCS 15)
149				
151	(149, 153)			
153				
157				
159	(157, 161)			
161				

Internal (dual-band) antenna with peak gain = 6dBi

16.10.3 Panel Antenna Model Maximum Conducted Transmit Power Settings

The following is an AP-621 standard transmit power table (Japanese domain) per panel antenna in the 5GHz band:

20 MHZ CHANNEL	40 MHZ CHANNEL	LEGACY OFDM RATES (6,9,12,18,24,36,48,54 MBPS)	802.11n HT20 RATES (MCS 0 MCS 15)	802.11n HT40 RATES (MCS 0 MCS 15)
36		12.5	12.5	
38	(36, 40)	12.5	12.5	12.5
40		12.5	12.5	
42		12.5	12.5	
44		12.5	12.5	
46	(44, 48)	12.5	12.5	12.5
48		12.5	12.5	
52		12.5	12.5	
54	(52, 56)	12.5	12.5	12.5
56		12.5	12.5	
60		12.5	12.5	
62	(60, 64)	12.5	12.5	12.5
64		12.5	12.5	
100		18.0	18.0	
102	(100, 104)	18.0	18.0	18.0
104		18.0	18.0	
108		18.0	18.0	
112		18.0	18.0	
110	(108, 112)	18.0	18.0	18.0
116		18.0	18.0	
118	(116, 120)	18.0	18.0	18.0
120		18.0	18.0	
124		18.0	18.0	
126	(124, 128)	18.0	18.0	18.0
128		18.0	18.0	
132		18.0	18.0	
134	(132, 136)	18.0	18.0	18.0
136		18.0	18.0	
140		18.0	18.0	
149				

20 MHZ CHANNEL	40 MHZ CHANNEL	LEGACY OFDM RATES (6,9,12,18,24,36,48,54 MBPS)	802.11n HT20 RATES (MCS 0 MCS 15)	802.11n HT40 RATES (MCS 0 MCS 15)
151	(149, 153)			
153				
157				
159	(157, 161)			
161				

Panel antenna with peak gain = 5dBi

16.10.4 Patch Antenna Model Maximum Conducted Transmit Power Settings

The following is an AP-621 standard transmit power table (Japanese domain) per patch antenna in the 5GHz band:

20 MHZ CHANNEL	40 MHZ CHANNEL	LEGACY OFDM RATES (6,9,12,18,24,36,48,54 MBPS)	802.11n HT20 RATES (MCS 0 MCS 15)	802.11n HT40 RATES (MCS 0 MCS 15)
36		12.5	12.5	
38	(36, 40)	12.5	12.5	12.5
40		12.5	12.5	
42		12.5	12.5	
44		12.5	12.5	
46	(44, 48)	12.5	12.5	12.5
48		12.5	12.5	
52		12.5	12.5	
54	(52, 56)	12.5	12.5	12.5
56		12.5	12.5	
60		12.5	12.5	
62	(60, 64)	12.5	12.5	12.5
64		12.5	12.5	
100		18.0	18.0	
102	(100, 104)	18.0	18.0	18.0
104		18.0	18.0	
108		18.0	18.0	
112		18.0	18.0	
110	(108, 112)	18.0	18.0	18.0
116		18.0	18.0	
118	(116, 120)	18.0	18.0	18.0
120		18.0	18.0	
124		18.0	18.0	
126	(124, 128)	18.0	18.0	18.0
128		18.0	18.0	
132		18.0	18.0	
134	(132, 136)	18.0	18.0	18.0
136		18.0	18.0	
140		18.0	18.0	
149				

20 MHZ CHANNEL	40 MHZ CHANNEL	LEGACY OFDM RATES (6,9,12,18,24,36,48,54 MBPS)	802.11n HT20 RATES (MCS 0 MCS 15)	802.11n HT40 RATES (MCS 0 MCS 15)
151	(149, 153)			
153				
157				
159	(157, 161)			
161				

Patch antenna with peak gain = 5dBi

16.11 AP-6521 (High Power) Japan Regulatory Domain 2.4GHz Band

The following are AP-6521 high power transmit tables (Japanese domain) per listed antenna in the 2.4GHz band:

16.11.1 Dipole (Dual-Band) or Outdoor Omni Dipole Antenna Model

The following is an AP-6521 high transmit power table (Japanese domain) per dipole (dual-band) or outdoor omni dipole antenna in the 2.4GHz band:

20 MHZ CHANNEL	40 MHZ CHANNEL	LEGACY DSSS RATES (1, 2, 5.5, 11 MBPS)	LEGACY OFDM RATES (6,9,12,18,24,36, 48,54 MBPS)	802.11n HT20 RATES (MCS 0 MCS 15)	802.11n HT40 RATES (MCS 0 MCS15)
1		17	19	19	
2		17	19	19	
3	(1, 5)	17	19	19	22
4	(2, 6)	17	19	19	22
5	(3, 7)	17	19	19	22
6	(4, 8)	17	19	19	22
7	(5, 9)	17	19	19	22
8	(6, 10)	17	19	19	22
9	(7, 11)	17	19	19	22
10	(8, 12)	17	19	19	22
11	(9, 13)	17	19	19	22
12		17	19	19	
13		17	19	19	
14					

Dipole (dual-band) or outdoor omni dipole antenna with peak gain = 3dBi

16.11.2 Internal (Dual-Band) Antenna Model

The following is an AP-6521 high transmit power table (Japanese domain) per internal (dual-band) antenna in the 2.4GHz band:

20 MHZ CHANNEL	40 MHZ CHANNEL	LEGACY DSSS RATES (1, 2, 5.5, 11 MBPS)	LEGACY OFDM RATES (6,9,12,18,24,36, 48,54 MBPS)	802.11n HT20 RATES (MCS 0 MCS 15)	802.11n HT40 RATES (MCS 0 MCS15)
1		17	19	19	
2		17	19	19	
3	(1, 5)	17	19	19	22
4	(2, 6)	17	19	19	22
5	(3, 7)	17	19	19	22
6	(4, 8)	17	19	19	22
7	(5, 9)	17	19	19	22
8	(6, 10)	17	19	19	22
9	(7, 11)	17	19	19	22
10	(8, 12)	17	19	19	22
11	(9, 13)	17	19	19	22
12		17	19	19	
13		17	19	19	
14					

Internal (dual-band) antenna with peak gain = 3dBi

16.11.3 Panel Antenna Model

The following is an AP-6521 high transmit power table (Japanese domain) per panel antenna in the 2.4GHz band:

20 MHZ CHANNEL	40 MHZ CHANNEL	LEGACY DSSS RATES (1, 2, 5.5, 11 MBPS)	LEGACY OFDM RATES (6,9,12,18,24,36, 48,54 MBPS)	802.11n HT20 RATES (MCS 0 MCS 15)	802.11n HT40 RATES (MCS 0 MCS15)
1		16	17	17	
2		16	19	17	
3	(1, 5)	16	17	17	20
4	(2, 6)	16	17	17	20
5	(3, 7)	16	17	17	20
6	(4, 8)	16	17	17	20
7	(5, 9)	16	17	17	20
8	(6, 10)	16	17	17	20
9	(7, 11)	16	17	17	20
10	(8, 12)	16	17	17	20
11	(9, 13)	16	17	17	20
12		16	17	17	
13		16	17	17	
14					

Panel antenna with peak gain = 4.5dBi

16.11.4 Patch Antenna Model

The following is an AP-6521 high transmit power table (Japanese domain) per patch antenna in the 2.4GHz band:

20 MHZ CHANNEL	40 MHZ CHANNEL	LEGACY DSSS RATES (1, 2, 5.5, 11 MBPS)	LEGACY OFDM RATES (6,9,12,18,24,36, 48,54 MBPS)	802.11n HT20 RATES (MCS 0 MCS 15)	802.11n HT40 RATES (MCS 0 MCS15)
1		16	17	17	
2		16	19	17	
3	(1, 5)	16	17	17	20
4	(2, 6)	16	17	17	20
5	(3, 7)	16	17	17	20
6	(4, 8)	16	17	17	20
7	(5, 9)	16	17	17	20
8	(6, 10)	16	17	17	20
9	(7, 11)	16	17	17	20
10	(8, 12)	16	17	17	20
11	(9, 13)	16	17	17	20
12		16	17	17	
13		16	17	17	
14					

Patch antenna with peak gain = 5dBi

16.12 AP-6521 (High Power) Japan Regulatory Domain 5GHz Band

The following are AP-6521 high power tables (Japanese domain) per listed antenna in the 5GHz band:

16.12.1 Dipole (Dual-Band) or Outdoor Omni Dipole Antenna Model Maximum Conducted Transmit Power Settings

The following is an AP-6521 high transmit power table (Japanese domain) per dipole (dual-band) or outdoor omni dipole antenna in the 5GHz band:

20 MHZ CHANNEL	40 MHZ CHANNEL	LEGACY OFDM RATES (6,9,12,18,24,36,48,54 MBPS)	802.11n HT20 RATES (MCS 0 MCS 15)	802.11n HT40 RATES (MCS 0 MCS 15)
36		10.0	12.5	
38	(36, 40)	12.5	12.5	12.5
40		12.5	12.5	
42		12.5	12.5	
44		12.5	12.5	
46	(44, 48)	12.5	12.5	12.5
48		12.5	12.5	
52		12.5	12.5	
54	(52, 56)	12.5	12.5	12.5
56		12.5	12.5	
60		12.5	12.5	
62	(60, 64)	12.5	12.5	12.5
64		12.5	12.5	
100		18.0	18.0	
102	(100, 104)	18.0	18.0	18.0
104		18.0	18.0	
108		18.0	18.0	
112		18.0	18.0	
110	(108, 112)	18.0	18.0	18.0
116		18.0	18.0	
118	(116, 120)	18.0	18.0	18.0
120		18.0	18.0	
124		18.0	18.0	
126	(124, 128)	18.0	18.0	18.0
128		18.0	18.0	
132		18.0	18.0	

20 MHZ CHANNEL	40 MHZ CHANNEL	LEGACY OFDM RATES (6,9,12,18,24,36,48,54 MBPS)	802.11n HT20 RATES (MCS 0 MCS 15)	802.11n HT40 RATES (MCS 0 MCS 15)
134	(132, 136)	18.0	18.0	18.0
136		18.0	18.0	
140		18.0	18.0	
149				
151	(149, 153)			
153				
157				
159	(157, 161)			
161				

Dipole (dual-band) or outdoor omni dipole antenna with peak gain = 5dBi

16.12.2 Internal (Dual-Band) Antenna Model Maximum Conducted Transmit Power Settings

The following is an AP-6521 high transmit power table (Japanese domain) per internal (dual-band) antenna in the 5GHz band:

20 MHZ CHANNEL	40 MHZ CHANNEL	LEGACY OFDM RATES (6,9,12,18,24,36,48,54 MBPS)	802.11n HT20 RATES (MCS 0 MCS 15)	802.11n HT40 RATES (MCS 0 MCS 15)
36		11.5	11.5	
38	(36, 40)	11.5	11.5	11.5
40		11.5	11.5	
42		11.5	11.5	
44		11.5	11.5	
46	(44, 48)	11.5	11.5	11.5
48		11.5	11.5	
52		11.5	11.5	
54	(52, 56)	11.5	11.5	11.5
56		11.5	11.5	
60		11.5	11.5	
62	(60, 64)	11.5	11.5	11.5
64		11.5	11.5	
100		17.0	17.0	
102	(100, 104)	17.0	17.0	17.0
104		17.0	17.0	
108		17.0	17.0	
112		17.0	17.0	
110	(108, 112)	17.0	17.0	17.0
116		17.0	17.0	
118	(116, 120)	17.0	17.0	18.0
120		17.0	17.0	
124		17.0	17.0	
126	(124, 128)	17.0	17.0	17.0
128		17.0	17.0	
132		17.0	17.0	
134	(132, 136)	17.0	17.0	17.0
136		17.0	17.0	
140		17.0	17.0	

20 MHZ CHANNEL	40 MHZ CHANNEL	LEGACY OFDM RATES (6,9,12,18,24,36,48,54 MBPS)	802.11n HT20 RATES (MCS 0 MCS 15)	802.11n HT40 RATES (MCS 0 MCS 15)
149				
151	(149, 153)			
153				
157				
159	(157, 161)			
161				

Internal (dual-band) antenna with peak gain = 6dBi

16.12.3 Panel Antenna Model Maximum Conducted Transmit Power Settings

The following is an AP-6521 high transmit power table (Japanese domain) per panel antenna in the 5GHz band:

20 MHZ CHANNEL	40 MHZ CHANNEL	LEGACY OFDM RATES (6,9,12,18,24,36,48,54 MBPS)	802.11n HT20 RATES (MCS 0 MCS 15)	802.11n HT40 RATES (MCS 0 MCS 15)
36		12.5	12.5	
38	(36, 40)	12.5	12.5	12.5
40		12.5	12.5	
42		12.5	12.5	
44		12.5	12.5	
46	(44, 48)	12.5	12.5	12.5
48		12.5	12.5	
52		12.5	12.5	
54	(52, 56)	12.5	12.5	12.5
56		12.5	12.5	
60		12.5	12.5	
62	(60, 64)	12.5	12.5	12.5
64		12.5	12.5	
100		18.0	18.0	
102	(100, 104)	18.0	18.0	18.0
104		18.0	18.0	
108		18.0	18.0	
112		18.0	18.0	
110	(108, 112)	18.0	18.0	18.0
116		18.0	18.0	
118	(116, 120)	18.0	18.0	18.0
120		18.0	18.0	
124		18.0	18.0	
126	(124, 128)	18.0	18.0	18.0
128		18.0	18.0	
132		18.0	18.0	
134	(132, 136)	18.0	18.0	18.0
136		18.0	18.0	
140		18.0	18.0	
149				

20 MHZ CHANNEL	40 MHZ CHANNEL	LEGACY OFDM RATES (6,9,12,18,24,36,48,54 MBPS)	802.11n HT20 RATES (MCS 0 MCS 15)	802.11n HT40 RATES (MCS 0 MCS 15)
151	(149, 153)			
153				
157				
159	(157, 161)			
161				

Panel antenna with peak gain = 5dBi

16.12.4 Patch Antenna Model Maximum Conducted Transmit Power Settings

The following is an AP-6521 high transmit power table (Japanese domain) per patch antenna in the 5GHz band:

20 MHZ CHANNEL	40 MHZ CHANNEL	LEGACY OFDM RATES (6,9,12,18,24,36,48,54 MBPS)	802.11n HT20 RATES (MCS 0 MCS 15)	802.11n HT40 RATES (MCS 0 MCS 15)
36		12.5	12.5	
38	(36, 40)	12.5	12.5	12.5
40		12.5	12.5	
42		12.5	12.5	
44		12.5	12.5	
46	(44, 48)	12.5	12.5	12.5
48		12.5	12.5	
52		12.5	12.5	
54	(52, 56)	12.5	12.5	12.5
56		12.5	12.5	
60		12.5	12.5	
62	(60, 64)	12.5	12.5	12.5
64		12.5	12.5	
100		18.0	18.0	
102	(100, 104)	18.0	18.0	18.0
104		18.0	18.0	
108		18.0	18.0	
112		18.0	18.0	
110	(108, 112)	18.0	18.0	18.0
116		18.0	18.0	
118	(116, 120)	18.0	18.0	18.0
120		18.0	18.0	
124		18.0	18.0	
126	(124, 128)	18.0	18.0	18.0
128		18.0	18.0	
132		18.0	18.0	
134	(132, 136)	18.0	18.0	18.0
136		18.0	18.0	
140		18.0	18.0	
149				

20 MHZ CHANNEL	40 MHZ CHANNEL	LEGACY OFDM RATES (6,9,12,18,24,36,48,54 MBPS)	802.11n HT20 RATES (MCS 0 MCS 15)	802.11n HT40 RATES (MCS 0 MCS 15)
151	(149, 153)			
153				
157				
159	(157, 161)			
161				

Patch antenna with peak gain = 5dBi

AP622 Regulatory Domains

17.1 US Regulatory Domain 2.4 GHz Band

17.1.1 Internal Antenna Maximum Conducted Transmit Power Settings

The following is a transmit power table (US domain) per internal antenna in the 2.4 GHz band:

20 MHZ CHANNEL	40 MHZ CHANNEL	LEGACY DSSS RATES (1, 2, 5.5, 11 MBPS)	LEGACY OFDM RATES (6,9,12,18,24,36, 48,54 MBPS)	802.11n HT20 RATES (MCS 0 MCS 15)	802.11n HT40 RATES (MCS 0 MCS15)
1		21.0	16.0	14.0	
2		21.0	21.0	21.0	
3	(1, 5)	21.0	21.0	21.0	11.5
4	(2, 6)	21.0	21.0	21.0	14.5
5	(3, 7)	21.0	21.0	21.0	14.5
6	(4, 8)	21.0	21.0	21.0	14.5
7	(5, 9)	21.0	21.0	21.0	14.5
8	(6, 10)	21.0	21.0	21.0	14.5
9	(7, 11)	21.0	21.0	21.0	13.0
10	(8, 12)	21.0	21.0	21.0	
11	(9, 13)	20.5	15.5	13.5	

Internal antenna, peak gain = 3.9dBi

17.1.2 Dipole Omni Antenna Maximum Conducted Transmit Power Settings

The following is a transmit power table (US domain) per dipole omni antenna in the 2.4 GHz band:

20 MHZ CHANNEL	40 MHZ CHANNEL	LEGACY DSSS RATES (1, 2, 5.5, 11 MBPS)	LEGACY OFDM RATES (6,9,12,18,24,36, 48,54 MBPS)	802.11n HT20 RATES (MCS 0 MCS 15)	802.11n HT40 RATES (MCS 0 MCS15)
1		21.0	15.5	15.0	
2		21.0	21.0	21.0	
3	(1, 5)	21.0	21.0	21.0	12.0
4	(2, 6)	21.0	21.0	21.0	15.0
5	(3, 7)	21.0	21.0	21.0	15.0
6	(4, 8)	21.0	21.0	21.0	15.0
7	(5, 9)	21.0	21.0	21.0	15.0
8	(6, 10)	21.0	21.0	21.0	15.0
9	(7, 11)	21.0	21.0	21.0	11.5
10	(8, 12)	21.0	21.0	21.0	
11	(9, 13)	20.5	16.0	13.0	

Dipole omni antenna, peak gain = 8.5dBi

17.1.3 Panel Antenna Maximum Conducted Transmit Power Settings

The following is a transmit power table (US domain) per panel antenna in the 2.4 GHz band:

20 MHZ CHANNEL	40 MHZ CHANNEL	LEGACY DSSS RATES (1, 2, 5.5, 11 MBPS)	LEGACY OFDM RATES (6,9,12,18,24,36, 48,54 MBPS)	802.11n HT20 RATES (MCS 0 MCS 15)	802.11n HT40 RATES (MCS 0 MCS15)
1		18.0	13.0	12.5	
2		20.0	14.0	14.5	
3	(1, 5)	20.0	14.0	14.5	8.5
4	(2, 6)	20.0	14.0	14.5	13.0
5	(3, 7)	20.0	14.0	14.5	13.0
6	(4, 8)	20.0	14.0	14.5	13.0
7	(5, 9)	20.0	14.0	14.5	13.0
8	(6, 10)	20.0	14.0	14.5	13.0
9	(7, 11)	20.0	14.0	14.5	8.0
10	(8, 12)	20.0	14.0	14.5	
11	(9, 13)	16.5	11.5	11.0	

Panel antenna, peak gain = 10.9dBi

17.1.4 Patch Antenna Maximum Conducted Transmit Power Settings

The following is a transmit power table (US domain) per patch antenna in the 2.4 GHz band:

20 MHZ CHANNEL	40 MHZ CHANNEL	LEGACY DSSS RATES (1, 2, 5.5, 11 MBPS)	LEGACY OFDM RATES (6,9,12,18,24,36, 48,54 MBPS)	802.11n HT20 RATES (MCS 0 MCS 15)	802.11n HT40 RATES (MCS 0 MCS15)
1		21.0	20.5	20.0	
2		21.0	21.0	21.0	
3	(1, 5)	21.0	21.0	21.0	17.5
4	(2, 6)	21.0	21.0	21.0	19.5
5	(3, 7)	21.0	21.0	21.0	19.5
6	(4, 8)	21.0	21.0	21.0	19.5
7	(5, 9)	21.0	21.0	21.0	19.5
8	(6, 10)	21.0	21.0	21.0	19.5
9	(7, 11)	21.0	21.0	21.0	14.5
10	(8, 12)	21.0	21.0	21.0	
11	(9, 13)	21.0	19.5	18.5	

Patch antenna, peak gain = 3.5dBi

17.1.5 Yagi Antenna Maximum Conducted Transmit Power Settings

The following is a transmit power table (US domain) per yagi antenna in the 2.4 GHz band:

20 MHZ CHANNEL	40 MHZ CHANNEL	LEGACY DSSS RATES (1, 2, 5.5, 11 MBPS)	LEGACY OFDM RATES (6,9,12,18,24,36, 48,54 MBPS)	802.11n HT20 RATES (MCS 0 MCS 15)	802.11n HT40 RATES (MCS 0 MCS15)
1		21.0	18.0	17.5	
2		21.0	21.0	21.0	
3	(1, 5)	21.0	21.0	21.0	14.5
4	(2, 6)	21.0	21.0	21.0	19.0
5	(3, 7)	21.0	21.0	21.0	19.0
6	(4, 8)	21.0	21.0	21.0	19.0
7	(5, 9)	21.0	21.0	21.0	19.0
8	(6, 10)	21.0	21.0	21.0	19.0
9	(7, 11)	21.0	21.0	21.0	14.0
10	(8, 12)	21.0	21.0	21.0	
11	(9, 13)	20.0	17.0	16.0	

Yagi antenna, peak gain = 11.1dBi

17.2 US Regulatory Domain 5 GHz Band

Dipole omni antenna, peak gain = 9dBi

17.2.1 Internal Antenna Model

The following is a transmit power table (US domain) per internal antenna in the 5 GHz band:

20 MHZ CHANNEL	40 MHZ CHANNEL	LEGACY OFDM RATES (6,9,12,18,24,36,48,54 MBPS)	802.11n HT20 RATES (MCS 0 MCS 15)	802.11n HT40 RATES (MCS 0 MCS 15)
36		10.5	13.5	
38	(36, 40)			13.0
40		11.0	13.0	
44		11.5	13.0	
46	(44, 48)			13.0
48		11.5	13.0	
52		19.0	20.0	
54	(52, 56)			20.0
56		18.5	20.0	
60		19.0	20.0	
62	(60, 64)			19.0
64		19.0	19.0	
100		20.0	18.0	
102	(100, 104)			17.0
104		20.0	19.0	
108		20.0	19.0	
110				18.5
112	(108, 112)	20.0	19.0	
116		20.0	19.0	
118	(116, 120)			
120				
124				
126	(124, 128)			
128				
132				
134	(132, 136)			20.0
136		20.0	19.0	

20 MHZ CHANNEL	40 MHZ CHANNEL	LEGACY OFDM RATES (6,9,12,18,24,36,48,54 MBPS)	802.11n HT20 RATES (MCS 0 MCS 15)	802.11n HT40 RATES (MCS 0 MCS 15)
140		18.5	20.0	
149		20.0	20.0	
151	(149, 153)			20.0
153		20.0	20.0	
157		20.0	20.0	
159	(157, 161)			20.0
161		20.0	20.0	
165		20.0	20.0	

Internal antenna, peak gain = 7.5dBi

17.2.2 Dipole Omni Antenna Model

The following is a transmit power table (US domain) per dipole omni antenna in the 5 GHz band:

20 MHZ CHANNEL	40 MHZ CHANNEL	LEGACY OFDM RATES (6,9,12,18,24,36,48,54 MBPS)	802.11n HT20 RATES (MCS 0 MCS 15)	802.11n HT40 RATES (MCS 0 MCS 15)
36		10.0	10.0	
38	(36, 40)			9.5
40		10.0	10.0	
44		10.0	10.0	
46	(44, 48)			10.0
48		10.5	10.5	
52		15.0	15.0	
54	(52, 56)			14.5
56		15.0	15.0	
60		15.0	15.0	
62	(60, 64)			14.5
64		15.0	15.0	
100		15.0	15.0	
102	(100, 104)			15.0
104		15.0	15.0	
108		15.0	15.0	
110				14.5
112	(108, 112)	15.0	15.0	
116		15.0	15.0	
118	(116, 120)			
120				
124				
126	(124, 128)			
128				
132				
134	(132, 136)			20.0
136		15.0	15.0	
140		15.0	15.0	
149		20.0	20.0	
151	(149, 153)			20.0
153		20.0	20.0	
157		20.0	20.0	

20 MHZ CHANNEL	40 MHZ CHANNEL	LEGACY OFDM RATES (6,9,12,18,24,36,48,54 MBPS)	802.11n HT20 RATES (MCS 0 MCS 15)	802.11n HT40 RATES (MCS 0 MCS 15)
159	(157, 161)			20.0
161		20.0	20.0	
165		20.0	20.0	

Dipole omni antenna, peak gain = 9dBi

17.2.3 Panel Antenna Model

The following is a transmit power table (US domain) per panel antenna in the 5 GHz band:

20 MHZ CHANNEL	40 MHZ CHANNEL	LEGACY OFDM RATES (6,9,12,18,24,36,48,54 MBPS)	802.11n HT20 RATES (MCS 0 MCS 15)	802.11n HT40 RATES (MCS 0 MCS 15)
36		11.5	11.0	
38	(36, 40)			10.5
40		11.5	11.0	
44		11.5	11.0	
46	(44, 48)			11.0
48		11.5	11.5	
52		15.5	16.0	
54	(52, 56)			15.5
56		15.5	16.0	
60		15.5	16.0	
62	(60, 64)			10.0
64		15.5	15.5	
100		15.5	15.5	
102	(100, 104)			15.0
104		15.5	15.0	
108		15.5	15.0	
110				14.5
112	(108, 112)	15.5	15.0	
116		15.0	15.0	
118	(116, 120)			
120				
124				
126	(124, 128)			
128				
132				
134	(132, 136)			15.5
136		15.0	15.0	
140		13.0	12.0	
149		20.0	19.0	
151	(149, 153)			19.0

20 MHZ CHANNEL	40 MHZ CHANNEL	LEGACY OFDM RATES (6,9,12,18,24,36,48,54 MBPS)	802.11n HT20 RATES (MCS 0 MCS 15)	802.11n HT40 RATES (MCS 0 MCS 15)
153		20.0	20.0	
157		20.0	20.0	
159	(157, 161)			20.0
161		20.0	20.0	
165		20.0	20.0	

Panel antenna, peak gain = 12.5dBi

17.2.4 Patch Antenna Model

The following is a transmit power table (US domain) per patch antenna in the 5 GHz band:

20 MHZ CHANNEL	40 MHZ CHANNEL	LEGACY OFDM RATES (6,9,12,18,24,36,48,54 MBPS)	802.11n HT20 RATES (MCS 0 MCS 15)	802.11n HT40 RATES (MCS 0 MCS 15)
36		14.0	14.0	
38	(36, 40)			13.5
40		14.5	14.5	
44		14.5	14.5	
46	(44, 48)			14.5
48		15.0	15.0	
52		19.5	19.5	
54	(52, 56)			19.0
56		19.5	19.5	
60		19.5	19.5	
62	(60, 64)			17.5
64		19.5	19.5	
100		20.0	20.0	
102	(100, 104)			15.5
104		20.0	20.0	
108		20.0	20.0	
110				19.5
112	(108, 112)	20.0	20.0	
116		20.0	20.0	
118	(116, 120)			
120				
124				
126	(124, 128)			
128				
132				
134	(132, 136)			20.0
136		20.0	20.0	
140		17.5	17.5	
149		20.0	20.0	
151	(149, 153)			20.0

20 MHZ CHANNEL	40 MHZ CHANNEL	LEGACY OFDM RATES (6,9,12,18,24,36,48,54 MBPS)	802.11n HT20 RATES (MCS 0 MCS 15)	802.11n HT40 RATES (MCS 0 MCS 15)
153		20.0	20.0	
157		20.0	20.0	
159	(157, 161)			20.0
161		20.0	20.0	
165		20.0	20.0	

Patch antenna, peak gain = 4.6dBi

17.2.5 Yagi Antenna Model

The following is a transmit power table (US domain) per yagi antenna in the 5 GHz band:

20 MHZ CHANNEL	40 MHZ CHANNEL	LEGACY OFDM RATES (6,9,12,18,24,36,48,54 MBPS)	802.11n HT20 RATES (MCS 0 MCS 15)	802.11n HT40 RATES (MCS 0 MCS 15)
36		13.0	13.0	
38	(36, 40)			12.0
40		13.0	13.0	
44		13.0	13.0	
46	(44, 48)			12.5
48		13.5	13.5	
52		17.5	17.5	
54	(52, 56)			17.0
56		17.5	17.5	
60		17.5	17.5	
62	(60, 64)			16.0
64		17.5	17.5	
100		18.0	18.0	
102	(100, 104)			17.5
104		18.0	18.0	
108		18.0	18.0	
110				17.5
112	(108, 112)	17.5	17.5	
116		17.5	17.5	
118	(116, 120)			
120				
124				
126	(124, 128)			
128				
132				
134	(132, 136)			18.0
136		18.0	18.0	
140		18.0	18.0	
149		20.0	20.0	
151	(149, 153)			20.0

20 MHZ CHANNEL	40 MHZ CHANNEL	LEGACY OFDM RATES (6,9,12,18,24,36,48,54 MBPS)	802.11n HT20 RATES (MCS 0 MCS 15)	802.11n HT40 RATES (MCS 0 MCS 15)
153		20.0	20.0	
157		20.0	20.0	
159	(157, 161)			20.0
161		20.0	20.0	
165		20.0	20.0	

Yagi antenna, peak gain = 11.0dBi

17.3 EU Regulatory Domain 2.4 GHz Band

17.3.1 Internal Antenna Model

The following is a transmit power table (EU domain) per internal antenna in the 2.4 GHz band:

20 MHZ CHANNEL	40 MHZ CHANNEL	LEGACY DSSS RATES (1, 2, 5.5, 11 MBPS)	LEGACY OFDM RATES (6,9,12,18,24,36, 48,54 MBPS)	802.11n HT20 RATES (MCS 0 MCS 15)	802.11n HT40 RATES (MCS 0 MCS15)
1		12.5	9.5	9.5	
2		12.5	9.5	9.5	
3	(1, 5)	12.5	9.5	9.5	9.0
4	(2, 6)	12.5	9.5	9.5	9.0
5	(3, 7)	12.5	9.5	9.5	9.0
6	(4, 8)	12.5	9.5	9.5	9.0
7	(5, 9)	12.5	9.5	9.5	9.0
8	(6, 10)	12.5	9.5	9.5	9.0
9	(7, 11)	12.5	9.5	9.5	9.0
10	(8, 12)	12.5	9.5	9.5	9.0
11	(9, 13)	12.5	9.5	9.5	9.0
12		12.5	9.5	9.5	
13		13.0	9.5	9.5	

Internal antenna, peak gain = 3.9dBi

17.3.2 Dipole Antenna Model

The following is a transmit power table (EU domain) per dipole antenna in the 2.4 GHz band:

20 MHZ CHANNEL	40 MHZ CHANNEL	LEGACY DSSS RATES (1, 2, 5.5, 11 MBPS)	LEGACY OFDM RATES (6,9,12,18,24,36, 48,54 MBPS)	802.11n HT20 RATES (MCS 0 MCS 15)	802.11n HT40 RATES (MCS 0 MCS15)
1		9.0	6.0	6.0	
2		9.5	6.5	6.0	
3	(1, 5)	9.5	6.5	6.0	5.5
4	(2, 6)	9.5	6.5	6.0	6.0
5	(3, 7)	9.5	6.5	6.0	6.0
6	(4, 8)	9.5	6.5	6.0	6.0
7	(5, 9)	9.5	6.5	6.0	6.0
8	(6, 10)	9.5	6.5	6.0	6.0
9	(7, 11)	9.5	6.5	6.0	6.0
10	(8, 12)	9.5	6.5	6.0	6.0
11	(9, 13)	9.5	6.5	6.0	6.0
12		9.5	6.5	6.0	
13		9.0	6.0	6.0	

Dipole antenna, peak gain = 8.5dBi

17.3.3 Panel Antenna Model

The following is a transmit power table (EU domain) per panel antenna in the 2.4 GHz band:

20 MHZ CHANNEL	40 MHZ CHANNEL	LEGACY DSSS RATES (1, 2, 5.5, 11 MBPS)	LEGACY OFDM RATES (6,9,12,18,24,36, 48,54 MBPS)	802.11n HT20 RATES (MCS 0 MCS 15)	802.11n HT40 RATES (MCS 0 MCS15)
1		6.5	6.0	6.0	
2		6.5	6.5	6.5	
3	(1, 5)	6.5	6.5	6.5	6.0
4	(2, 6)	6.5	6.5	6.5	6.0
5	(3, 7)	6.5	6.5	6.5	6.0
6	(4, 8)	6.5	6.5	6.5	6.0
7	(5, 9)	6.5	6.5	6.5	6.0
8	(6, 10)	6.5	6.5	6.5	6.0
9	(7, 11)	6.5	6.5	6.5	6.0
10	(8, 12)	6.5	6.5	6.5	6.0
11	(9, 13)	6.5	6.5	6.5	6.0
12		6.5	6.5	6.5	
13		6.5	5.5	5.5	

Panel antenna, peak gain = 10.9dBi

17.3.4 Patch Antenna Model

The following is a transmit power table (EU domain) per patch antenna in the 2.4 GHz band:

20 MHZ CHANNEL	40 MHZ CHANNEL	LEGACY DSSS RATES (1, 2, 5.5, 11 MBPS)	LEGACY OFDM RATES (6,9,12,18,24,36, 48,54 MBPS)	802.11n HT20 RATES (MCS 0 MCS 15)	802.11n HT40 RATES (MCS 0 MCS15)
1		14.0	11.5	11.0	
2		14.5	12.0	11.0	
3	(1, 5)	14.5	12.0	11.0	10.5
4	(2, 6)	14.5	12.0	11.0	11.0
5	(3, 7)	14.5	12.0	11.0	11.0
6	(4, 8)	14.5	12.0	11.0	11.0
7	(5, 9)	14.5	12.0	11.0	11.0
8	(6, 10)	14.5	12.0	11.0	11.0
9	(7, 11)	14.5	12.0	11.0	11.0
10	(8, 12)	14.5	12.0	11.0	11.0
11	(9, 13)	14.5	12.0	11.0	11.5
12		14.5	12.0	11.0	
13		14.0	11.5	10.0	

Patch antenna, peak gain = 3.5dBi

17.3.5 Yagi Antenna Model

The following is a transmit power table (EU domain) per yagi antenna in the 2.4 GHz band:

20 MHZ CHANNEL	40 MHZ CHANNEL	LEGACY DSSS RATES (1, 2, 5.5, 11 MBPS)	LEGACY OFDM RATES (6,9,12,18,24,36, 48,54 MBPS)	802.11n HT20 RATES (MCS 0 MCS 15)	802.11n HT40 RATES (MCS 0 MCS15)
1		6.5	6.5	6.5	
2		6.5	6.5	6.5	
3	(1, 5)	6.5	6.5	6.5	6.5
4	(2, 6)	6.5	6.5	6.5	6.5
5	(3, 7)	6.5	6.5	6.5	6.5
6	(4, 8)	6.5	6.5	6.5	6.5
7	(5, 9)	6.5	6.5	6.5	6.5
8	(6, 10)	6.5	6.5	6.5	6.5
9	(7, 11)	6.5	6.5	6.5	6.5
10	(8, 12)	6.5	6.5	6.5	6.5
11	(9, 13)	6.5	6.5	6.5	6.5
12		6.5	6.5	6.5	
13		6.5	6.0	6.0	

Yagi antenna, peak gain = 11.1dBi

17.4 EU Regulatory Domain 5 GHz Band

17.4.1 Internal Antenna Model

The following is a transmit power table (EU domain) per internal antenna in the 5 GHz band:

20 MHZ CHANNEL	40 MHZ CHANNEL	LEGACY OFDM RATES (6,9,12,18,24,36,48,54 MBPS)	802.11n HT20 RATES (MCS 0 MCS 15)	802.11n HT40 RATES (MCS 0 MCS 15)
36		9.0	9.0	
38	(36, 40)			9.0
40		9.0	9.0	
44		9.0	9.0	
46	(44, 48)			9.0
48		9.0	9.0	
52		5.5	5.5	
54	(52, 56)			6.0
56		5.5	5.5	
60		5.5	5.5	
62	(60, 64)			6.0
64		5.5	5.5	
100		13.0	13.0	
102	(100, 104)			12.5
104		13.0	13.0	
108		13.0	13.0	
110				12.5
112	(108, 112)	13.0	13.0	
116		13.0	13.0	
118	(116, 120)			
120				
124				
126	(124, 128)			
128				
132				
134	(132, 136)			13.0
136		13.0	13.0	
140		13.0	13.0	
149				

20 MHZ CHANNEL	40 MHZ CHANNEL	LEGACY OFDM RATES (6,9,12,18,24,36,48,54 MBPS)	802.11n HT20 RATES (MCS 0 MCS 15)	802.11n HT40 RATES (MCS 0 MCS 15)
151	(149, 153)			
153				
157				
159	(157, 161)			
161				
165				

Internal antenna, peak gain = 7.5dBi

17.4.2 Dipole Omni Antenna Model

The following is a transmit power table (EU domain) per dipole omni antenna in the 5 GHz band:

20 MHZ CHANNEL	40 MHZ CHANNEL	LEGACY OFDM RATES (6,9,12,18,24,36,48,54 MBPS)	802.11n HT20 RATES (MCS 0 MCS 15)	802.11n HT40 RATES (MCS 0 MCS 15)
36		7.5	7.5	
38	(36, 40)			6.0
40		7.5	7.5	
44		7.5	7.5	
46	(44, 48)			6.0
48		7.5	7.5	
52		4.5	4.5	
54	(52, 56)			4.0
56		4.5	4.5	
60		4.5	4.5	
62	(60, 64)			4.0
64		4.5	4.5	
100		11.5	11.5	
102	(100, 104)			11.0
104		11.5	11.5	
108		11.5	11.5	
110				11.0
112	(108, 112)	11.5	11.5	
116		11.5	11.5	
118	(116, 120)			
120				
124				
126	(124, 128)			
128				
132				
134	(132, 136)			11.0
136		11.0	11.0	
140		11.0	11.0	
149				
151	(149, 153)			

20 MHZ CHANNEL	40 MHZ CHANNEL	LEGACY OFDM RATES (6,9,12,18,24,36,48,54 MBPS)	802.11n HT20 RATES (MCS 0 MCS 15)	802.11n HT40 RATES (MCS 0 MCS 15)
153				
157				
159	(157, 161)			
161				
165				

Dipole omni antenna, peak gain = 9dBi

17.4.3 Panel Antenna Model

The following is a transmit power table (EU domain) per panel antenna in the 5 GHz band:

20 MHZ CHANNEL	40 MHZ CHANNEL	LEGACY OFDM RATES (6,9,12,18,24,36,48,54 MBPS)	802.11n HT20 RATES (MCS 0 MCS 15)	802.11n HT40 RATES (MCS 0 MCS 15)
36		6.0	6.0	
38	(36, 40)			6.0
40		6.0	6.0	
44		6.0	6.0	
46	(44, 48)			6.0
48		6.0	6.0	
52		3.5	3.5	
54	(52, 56)			3.5
56		3.5	3.5	
60		3.5	3.5	
62	(60, 64)			3.5
64		3.5	3.5	
100		9.0	9.0	
102	(100, 104)			8.5
104		9.0	9.0	
108		9.0	9.0	
110				8.5
112	(108, 112)	9.0	9.0	
116		9.0	9.0	
118	(116, 120)			
120				
124				
126	(124, 128)			
128				
132				
134	(132, 136)			8.0
136		8.0	8.0	
140		8.0	8.0	
149				
151	(149, 153)			

20 MHZ CHANNEL	40 MHZ CHANNEL	LEGACY OFDM RATES (6,9,12,18,24,36,48,54 MBPS)	802.11n HT20 RATES (MCS 0 MCS 15)	802.11n HT40 RATES (MCS 0 MCS 15)
153				
157				
159	(157, 161)			
161				
165				

Panel antenna, peak gain = 12.5dBi

17.4.4 Patch Antenna Model

The following is a transmit power table (EU domain) per patch antenna in the 5 GHz band:

20 MHZ CHANNEL	40 MHZ CHANNEL	LEGACY OFDM RATES (6,9,12,18,24,36,48,54 MBPS)	802.11n HT20 RATES (MCS 0 MCS 15)	802.11n HT40 RATES (MCS 0 MCS 15)
36		11.5	11.5	
38	(36, 40)			11.0
40		11.5	11.5	
44		11.5	11.5	
46	(44, 48)			11.0
48		11.5	11.5	
52		8.5	8.5	
54	(52, 56)			8.0
56		8.5	8.5	
60		8.5	8.5	
62	(60, 64)			8.0
64		8.5	8.5	
100		15.0	15.0	
102	(100, 104)			15.5
104		15.0	15.0	
108		15.0	15.0	
110				15.5
112	(108, 112)	15.0	15.0	
116		15.0	15.0	
118	(116, 120)			
120				
124				
126	(124, 128)			
128				
132				
134	(132, 136)			16.0
136		15.0	15.0	
140		15.5	15.5	
149				
151	(149, 153)			

20 MHZ CHANNEL	40 MHZ CHANNEL	LEGACY OFDM RATES (6,9,12,18,24,36,48,54 MBPS)	802.11n HT20 RATES (MCS 0 MCS 15)	802.11n HT40 RATES (MCS 0 MCS 15)
153				
157				
159	(157, 161)			
161				
165				

Patch antenna, peak gain = 10dBi

17.4.5 Yagi Antenna Model

The following is a transmit power table (EU domain) per yagi antenna in the 5 GHz band:

20 MHZ CHANNEL	40 MHZ CHANNEL	LEGACY OFDM RATES (6,9,12,18,24,36,48,54 MBPS)	802.11n HT20 RATES (MCS 0 MCS 15)	802.11n HT40 RATES (MCS 0 MCS 15)
36		8.0	8.0	
38	(36, 40)			7.5
40		8.0	8.0	
44		8.0	8.0	
46	(44, 48)			7.5
48		8.0	8.0	
52		4.0	4.0	
54	(52, 56)			3.5
56		4.0	4.0	
60		4.0	4.0	
62	(60, 64)			3.5
64		4.0	4.0	
100		10.5	10.5	
102	(100, 104)			9.5
104		10.5	10.5	
108		10.5	10.5	
110				9.5
112	(108, 112)	10.5	10.5	
116		10.5	10.5	
118	(116, 120)			
120				
124				
126	(124, 128)			
128				
132				
134	(132, 136)			9.5
136		10.5	10.5	
140		9.5	9.5	
149				
151	(149, 153)			

20 MHZ CHANNEL	40 MHZ CHANNEL	LEGACY OFDM RATES (6,9,12,18,24,36,48,54 MBPS)	802.11n HT20 RATES (MCS 0 MCS 15)	802.11n HT40 RATES (MCS 0 MCS 15)
153				
157				
159	(157, 161)			
161				
165				

Yagi antenna, peak gain = 11dBi

18

AP7161 Regulatory Domains

18.1 US Regulatory Domain 2.4 GHz Band

18.1.1 Dipole Omni Antenna Maximum Conducted Transmit Power Settings

The following is a transmit power table (US domain) per dipole omni antenna in the 2.4 GHz band:

<i>20 MHZ CHANNEL</i>	<i>40 MHZ CHANNEL</i>	<i>LEGACY DSSS RATES (1, 2, 5.5, 11 MBPS)</i>	<i>LEGACY OFDM RATES (6,9,12,18,24,36, 48,54 MBPS)</i>	<i>802.11n HT20 RATES (MCS 0 MCS 15)</i>	<i>802.11n HT40 RATES (MCS 0 MCS15)</i>
1		18.5	16.5	16.5	
2		19.0	16.5	16.5	
3	(1, 5)	19.0	16.5	16.5	15.5
4	(2, 6)	19.0	16.5	16.5	15.5
5	(3, 7)	19.0	16.5	16.5	15.5
6	(4, 8)	19.0	16.5	16.5	15.0
7	(5, 9)	19.0	16.5	18.0	15.0
8	(6, 10)	19.0	16.5	18.0	15.0
9	(7, 11)	19.0	18.0	18.0	15.0
10		19.0	18.0	18.0	
11		18.0	18.0	18.0	

Internal antenna, peak gain = 8.0dBi

18.2 US Regulatory Domain 4.9 GHz Band

18.2.1 Dipole Omni Antenna Model - 3Tx Transmitter Configuration

The following is a transmit power table (US domain) per dipole omni antenna in the 4.9 GHz band (3Tx):

20 MHZ CHANNEL	40 MHZ CHANNEL	LEGACY DSSS RATES (1, 2, 5.5, 11 MBPS)	LEGACY OFDM RATES (6,9,12,18,24,36, 48,54 MBPS)	802.11n HT20 RATES (MCS 0 MCS 15)	802.11n HT40 RATES (MCS 0 MCS15)
21			9.5	9.5	
25			9.5	9.5	

Internal antenna, peak gain = 10.5dBi

18.2.2 Dipole Omni Antenna Model - 1Tx Transmitter Configuration

The following is a transmit power table (US domain) per dipole omni antenna in the 4.9 GHz band (1Tx):

20 MHZ CHANNEL	40 MHZ CHANNEL	LEGACY DSSS RATES (1, 2, 5.5, 11 MBPS)	LEGACY OFDM RATES (6,9,12,18,24,36, 48,54 MBPS)	802.11n HT20 RATES (MCS 0 MCS 15)	802.11n HT40 RATES (MCS 0 MCS15)
21			18.5	18.5	
25			19.0	19.0	

Internal antenna, peak gain = 10.5dBi

18.3 US Regulatory Domain 5 GHz Band

18.3.1 Dipole Omni Antenna Model

The following is a transmit power table (US domain) per dipole omni antenna in the 5 GHz band:

20 MHZ CHANNEL	40 MHZ CHANNEL	LEGACY OFDM RATES (6,9,12,18,24,36,48,54 MBPS)	802.11n HT20 RATES (MCS 0 MCS 15)	802.11n HT40 RATES (MCS 0 MCS 15)
36				
38	(36, 40)			
40				
44				
46	(44, 48)			
48				
52		9.5	10.0	
54	(52, 56)			120
56		9.5	10.0	
60		9.0	9.5	
62	(60, 64)			12.0
64		9.5	10.0	
100		7.5	8.0	
102	(100, 104)			10.5
104		9.5	10.0	
108		9.5	10.0	
110				10.5
112	(108, 112)	9.5	10.0	
116		9.5	10.0	
118	(116, 120)			
120		9.5	10.0	
124		11.0	11.0	
126	(124, 128)			12.5
128		11.0	11.0	
132		11.0	11.0	
134	(132, 136)			12.5
136		11.0	11.0	
140		11.0	11.0	
149		19.0	19.0	
151	(149, 153)			15.5
153		19.0	19.0	
157		17.0	16.5	

20 MHZ CHANNEL	40 MHZ CHANNEL	LEGACY OFDM RATES (6,9,12,18,24,36,48,54 MBPS)	802.11n HT20 RATES (MCS 0 MCS 15)	802.11n HT40 RATES (MCS 0 MCS 15)
159	(157, 161)			17.0
161		17.0	17.5	
165		17.0	17.5	

Yagi antenna, peak gain = 10.5dBi

18.4 EU Regulatory Domain 2.4 GHz Band

18.4.1 Dipole Omni Antenna Model

The following is a transmit power table (EU domain) per dipole omni antenna in the 2.4 GHz band:

20 MHZ CHANNEL	40 MHZ CHANNEL	LEGACY DSSS RATES (1, 2, 5.5, 11 MBPS)	LEGACY OFDM RATES (6,9,12,18,24,36, 48,54 MBPS)	802.11n HT20 RATES (MCS 0 MCS 15)	802.11n HT40 RATES (MCS 0 MCS15)
1		6.0	6.0	5.0	
2		6.0	6.0	5.0	
3	(1, 5)	6.0	6.0	5.0	7.0
4	(2, 6)	6.0	5.5	5.0	7.0
5	(3, 7)	6.0	5.5	5.0	7.0
6	(4, 8)	6.0	5.5	5.0	7.0
7	(5, 9)	6.0	5.5	5.0	7.0
8	(6, 10)	6.0	5.5	5.0	7.0
9	(7, 11)	6.0	5.0	5.0	7.0
10		6.0	5.0	5.0	
11		6.0	5.0	5.0	
12					
13					

Internal antenna, peak gain = 8.0dBi

18.5 EU Regulatory Domain 5 GHz Band

18.5.1 Dipole Omni Antenna Model

The following is a transmit power table (EU domain) per dipole omni antenna in the 5 GHz band:

20 MHZ CHANNEL	40 MHZ CHANNEL	LEGACY OFDM RATES (6,9,12,18,24,36,48,54 MBPS)	802.11n HT20 RATES (MCS 0 MCS 15)	802.11n HT40 RATES (MCS 0 MCS 15)
36		8.5	8.5	
38	(36, 40)			9.0
40		8.5	8.5	
44		8.5	8.5	
46	(44, 48)			9.0
48		8.5	8.5	
52		7.0	7.0	
54	(52, 56)			7.5
56		7.0	7.0	
60		7.0	7.0	
62	(60, 64)			7.5
64		7.0	7.0	
100		14.5	14.5	
102	(100, 104)			16.0
104		14.5	14.5	
108		14.5	14.5	
110				16.0
112	(108, 112)	14.5	14.5	
116		14.5	14.5	
118	(116, 120)			16.0
120		14.5	14.5	
124		14.5	14.5	
126	(124, 128)			16.0
128		14.5	14.5	
132		14.5	14.5	
134	(132, 136)			16.0
136		14.5	14.5	
140		14.5	14.5	
149		10.5	10.5	

20 MHZ CHANNEL	40 MHZ CHANNEL	LEGACY OFDM RATES (6,9,12,18,24,36,48,54 MBPS)	802.11n HT20 RATES (MCS 0 MCS 15)	802.11n HT40 RATES (MCS 0 MCS 15)
151	(149, 153)			
153		10.5	10.5	
157		10.5	10.5	
159	(157, 161)			
161		10.0	10.0	
165		10.0	10.0	

Internal antenna, peak gain = 10.5dBi

18.6 Japan Regulatory Domain 2.4 GHz Band

18.6.1 Dipole Omni Antenna Model

The following is a transmit power table (Japanese domain) per dipole omni antenna in the 2.4 GHz band:

20 MHZ CHANNEL	40 MHZ CHANNEL	LEGACY DSSS RATES (1, 2, 5.5, 11 MBPS)	LEGACY OFDM RATES (6,9,12,18,24,36, 48,54 MBPS)	802.11n HT20 RATES (MCS 0 MCS 15)	802.11n HT40 RATES (MCS 0 MCS15)
1		16.5	13.0	13.5	
2		16.5	13.0	13.5	
3	(1, 5)	16.5	13.0	13.5	13.5
4	(2, 6)	16.5	13.0	13.5	13.5
5	(3, 7)	16.5	13.0	13.5	13.5
6	(4, 8)	16.5	13.0	13.5	13.5
7	(5, 9)	16.5	13.0	13.5	13.5
8	(6, 10)	16.5	13.0	13.5	13.5
9	(7, 11)	16.5	13.0	13.5	13.5
10	(8, 12)	16.5	13.0	13.5	
11	(9, 13)	16.5	13.0	13.5	
12		16.5	13.0	13.5	
13		16.5	13.0	13.5	

Internal antenna, peak gain = 8.0dBi

18.7 Japan Regulatory Domain 5 GHz Band

18.7.1 Dipole Omni Antenna Model

The following is a transmit power table (Japanese domain) per dipole omni antenna in the 5 GHz band:

20 MHZ CHANNEL	40 MHZ CHANNEL	LEGACY OFDM RATES (6,9,12,18,24,36,48,54 MBPS)	802.11n HT20 RATES (MCS 0 MCS 15)	802.11n HT40 RATES (MCS 0 MCS 15)
36		10.0	10.5	
38	(36, 40)			11.0
40		10.0	10.5	
44		10.0	10.5	
46	(44, 48)			11.0
48		10.0	10.5	
52		10.0	10.5	
54	(52, 56)			10.5
56		10.0	10.5	
60		10.0	10.5	
62	(60, 64)			10.5
64		10.0	10.5	
100		15.0	15.5	
102	(100, 104)			16.0
104		15.0	15.5	
108		15.0	15.5	
110				16.0
112	(108, 112)	15.0	15.5	
116		15.0	15.5	
118	(116, 120)			16.0
120		15.0	15.5	
124		15.0	15.5	
126	(124, 128)			16.0
128		15.0	15.5	
132		15.0	15.5	
134	(132, 136)			16.0
136		15.0	15.5	
140		15.0	15.5	
149				
151	(149, 153)			

20 MHZ CHANNEL	40 MHZ CHANNEL	LEGACY OFDM RATES (6,9,12,18,24,36,48,54 MBPS)	802.11n HT20 RATES (MCS 0 MCS 15)	802.11n HT40 RATES (MCS 0 MCS 15)
153				
157				
159	(157, 161)			
161				
165				

Internal antenna, peak gain = 10.5dBi

19

AP8132 Regulatory Domains

19.1 US Regulatory Domain 2.4 GHz Band

19.1.1 External Dipole Antenna Maximum Conducted Transmit Power Settings

The following is a transmit power table (US domain) per external dipole antenna in the 2.4 GHz band:

20 MHZ CHANNEL	40 MHZ CHANNEL	LEGACY DSSS RATES (1, 2, 5.5, 11 MBPS)	LEGACY OFDM RATES (6,9,12,18,24,36, 48,54 MBPS)	802.11n HT20 RATES (MCS 0 MCS 15)	802.11n HT40 RATES (MCS 0 MCS15)
1		17.0	17.0	16.0	
2		17.0	17.0	17.0	
3	(1, 5)	18.0	21.0	21.0	13.0
4	(2, 6)	18.0	21.0	21.0	13.0
5	(3, 7)	18.0	21.0	21.0	19.0
6	(4, 8)	18.0	21.0	21.0	19.0
7	(5, 9)	18.0	21.0	21.0	19.0
8	(6, 10)	18.0	21.0	21.0	10.0
9	(7, 11)	18.0	21.0	21.0	10.0
10		18.0	17.0	17.0	
11		18.0	17.0	17.0	

External dipole antenna, peak gain = 10.5dBi

19.1.2 External Panel Antenna Maximum Conducted Transmit Power Settings

The following is a transmit power table (US domain) per external panel antenna in the 2.4 GHz band:

20 MHZ CHANNEL	40 MHZ CHANNEL	LEGACY DSSS RATES (1, 2, 5.5, 11 MBPS)	LEGACY OFDM RATES (6,9,12,18,24,36, 48,54 MBPS)	802.11n HT20 RATES (MCS 0 MCS 15)	802.11n HT40 RATES (MCS 0 MCS15)
1		7.0	13.0	13.0	
2		17.0	17.0	17.0	
3	(1, 5)	17.0	17.0	17.0	10.0
4	(2, 6)	17.0	17.0	17.0	10.0
5	(3, 7)	17.0	17.0	17.0	14.0
6	(4, 8)	17.0	17.0	17.0	14.0
7	(5, 9)	17.0	17.0	17.0	14.0
8	(6, 10)	17.0	17.0	17.0	6.0
9	(7, 11)	17.0	17.0	17.0	6.0
10		17.0	17.0	17.0	
11		16.0	15.0	15.0	

External Panel antenna, peak gain = 15dBi

19.1.3 External Yagi Antenna Maximum Conducted Transmit Power Settings

The following is a transmit power table (US domain) per external yagi antenna in the 2.4 GHz band:

20 MHZ CHANNEL	40 MHZ CHANNEL	LEGACY DSSS RATES (1, 2, 5.5, 11 MBPS)	LEGACY OFDM RATES (6,9,12,18,24,36, 48,54 MBPS)	802.11n HT20 RATES (MCS 0 MCS 15)	802.11n HT40 RATES (MCS 0 MCS15)
1		8.0	9.0	9.0	
2		8.0	13.0	13.0	
3	(1, 5)	17.0	13.0	13.0	9.0
4	(2, 6)	17.0	13.0	13.0	9.0
5	(3, 7)	17.0	13.0	13.0	12.0
6	(4, 8)	17.0	13.0	13.0	12.0
7	(5, 9)	17.0	13.0	13.0	12.0
8	(6, 10)	17.0	13.0	13.0	6.0
9	(7, 11)	17.0	13.0	13.0	6.0
10		6.0	13.0	13.0	
11		6.0	13.0	13.0	

External yagi antenna, peak gain = 14.5dBi

19.1.4 External Patch Antenna Maximum Conducted Transmit Power Settings

The following is a transmit power table (US domain) per external patch antenna in the 2.4 GHz band:

20 MHZ CHANNEL	40 MHZ CHANNEL	LEGACY DSSS RATES (1, 2, 5.5, 11 MBPS)	LEGACY OFDM RATES (6,9,12,18,24,36, 48,54 MBPS)	802.11n HT20 RATES (MCS 0 MCS 15)	802.11n HT40 RATES (MCS 0 MCS15)
1		20.0	17.0	17.0	
2		23.0	23.0	23.0	
3	(1, 5)	23.0	23.0	23.0	13.0
4	(2, 6)	23.0	23.0	23.0	13.0
5	(3, 7)	23.0	23.0	23.0	18.0
6	(4, 8)	23.0	23.0	23.0	18.0
7	(5, 9)	23.0	23.0	23.0	18.0
8	(6, 10)	23.0	23.0	23.0	14.0
9	(7, 11)	23.0	23.0	23.0	14.0
10		23.0	23.0	23.0	
11		19.0	17.0	17.0	

External patch antenna, peak gain = 4dBi

19.1.5 Internal Facade Antenna Maximum Conducted Transmit Power Settings

The following is a transmit power table (US domain) per internal facade antenna in the 2.4 GHz band:

20 MHZ CHANNEL	40 MHZ CHANNEL	LEGACY DSSS RATES (1, 2, 5.5, 11 MBPS)	LEGACY OFDM RATES (6,9,12,18,24,36, 48,54 MBPS)	802.11n HT20 RATES (MCS 0 MCS 15)	802.11n HT40 RATES (MCS 0 MCS15)
1		20.0	18.0	18.0	
2		23.0	23.0	23.0	
3	(1, 5)	23.0	23.0	23.0	14.0
4	(2, 6)	23.0	23.0	23.0	18.0
5	(3, 7)	23.0	23.0	23.0	18.0
6	(4, 8)	23.0	23.0	23.0	18.0
7	(5, 9)	23.0	23.0	23.0	18.0
8	(6, 10)	23.0	23.0	23.0	18.0
9	(7, 11)	23.0	23.0	23.0	14.0
10		23.0	23.0	23.0	
11		20.0	19.0	19.0	

Internal facade antenna, peak gain = 3.5dBi

19.2 US Regulatory Domain 5 GHz Band

19.2.1 External Dipole Antenna Model

The following is a transmit power table (US domain) per external dipole antenna in the 5 GHz band:

20 MHZ CHANNEL	40 MHZ CHANNEL	LEGACY OFDM RATES (6,9,12,18,24,36,48,54 MBPS)	802.11n HT20 RATES (MCS 0 MCS 15)	802.11n HT40 RATES (MCS 0 MCS 15)
36		8.0	8.0	
38	(36, 40)	8.0	8.0	8.0
40		8.0	8.0	
44		8.0	8.0	
46	(44, 48)	8.0	8.0	9.0
48		8.0	8.0	
52		9.0	9.0	
54	(52, 56)	9.0	9.0	9.0
56		9.0	9.0	
60		9.0	9.0	
62	(60, 64)	9.0	9.0	9.0
64		9.0	9.0	
100		15.0	15.0	
102	(100, 104)	15.0	15.0	15.0
104		15.0	15.0	
108		15.0	15.0	
110		15.0	15.0	15.0
112		15.0	15.0	
116		15.0	15.0	
118	(116, 120)	15.0	15.0	15.0
120		15.0	15.0	
124		15.0	15.0	
126	(124, 128)	15.0	15.0	15.0
128		15.0	15.0	
132		15.0	15.0	
134	(132, 136)	15.0	15.0	15.0
136		15.0	15.0	
140		15.0	15.0	
149		20.0	20.0	

20 MHZ CHANNEL	40 MHZ CHANNEL	LEGACY OFDM RATES (6,9,12,18,24,36,48,54 MBPS)	802.11n HT20 RATES (MCS 0 MCS 15)	802.11n HT40 RATES (MCS 0 MCS 15)
151	(149, 153)	20.0	20.0	20.0
153		20.0	20.0	
157		20.0	20.0	
159	(157, 161)	20.0	20.0	20.0
161		20.0	20.0	
165		20.0	20.0	

External dipole antenna, peak gain = 10.5dBi

19.2.2 External Panel Antenna Model

The following is a transmit power table (US domain) per external panel antenna in the 5 GHz band:

20 MHZ CHANNEL	40 MHZ CHANNEL	LEGACY OFDM RATES (6,9,12,18,24,36,48,54 MBPS)	802.11n HT20 RATES (MCS 0 MCS 15)	802.11n HT40 RATES (MCS 0 MCS 15)
36		4.0	4.0	
38	(36, 40)	4.0	4.0	4.0
40		4.0	4.0	
44		4.0	4.0	
46	(44, 48)	4.0	4.0	4.0
48		4.0	4.0	
52		4.0	4.0	
54	(52, 56)	4.0	4.0	4.0
56		4.0	4.0	
60		4.0	4.0	
62	(60, 64)	4.0	4.0	4.0
64		4.0	4.0	
100		4.0	4.0	
102	(100, 104)	4.0	4.0	4.0
104		4.0	4.0	
108		4.0	4.0	
110		4.0	4.0	4.0
112		4.0	4.0	
116		4.0	4.0	
118	(116, 120)	4.0	4.0	4.0
120		4.0	4.0	
124		4.0	4.0	
126	(124, 128)	4.0	4.0	4.0
128		4.0	4.0	
132		4.0	4.0	
134	(132, 136)	4.0	4.0	4.0
136		4.0	4.0	
140		4.0	4.0	
149		20.0	20.0	
151	(149, 153)	20.0	20.0	20.0
153		20.0	20.0	
157		20.0	20.0	

20 MHZ CHANNEL	40 MHZ CHANNEL	LEGACY OFDM RATES (6,9,12,18,24,36,48,54 MBPS)	802.11n HT20 RATES (MCS 0 MCS 15)	802.11n HT40 RATES (MCS 0 MCS 15)
159	(157, 161)	20.0	20.0	20.0
161		20.0	20.0	
165		20.0	20.0	

External panel antenna, peak gain = 12dBi

19.2.3 External Yagi Antenna Model

The following is a transmit power table (US domain) per external yagi antenna in the 5 GHz band:

20 MHZ CHANNEL	40 MHZ CHANNEL	LEGACY OFDM RATES (6,9,12,18,24,36,48,54 MBPS)	802.11n HT20 RATES (MCS 0 MCS 15)	802.11n HT40 RATES (MCS 0 MCS 15)
36		8.0	8.0	
38	(36, 40)	8.0	8.0	8.0
40		8.0	8.0	
44		8.0	8.0	
46	(44, 48)	8.0	8.0	8.0
48		8.0	8.0	
52		9.0	9.0	
54	(52, 56)	9.0	9.0	9.0
56		9.0	9.0	
60		9.0	9.0	
62	(60, 64)	9.0	9.0	9.0
64		9.0	9.0	
100		15.0	15.0	
102	(100, 104)	15.0	15.0	15.0
104		15.0	15.0	
108		15.0	15.0	
110		15.0	15.0	15.0
112	(108, 112)	15.0	15.0	
116		15.0	15.0	
118	(116, 120)	15.0	15.0	15.0
120		15.0	15.0	
124		15.0	15.0	
126	(124, 128)	15.0	15.0	15.0
128		15.0	15.0	
132		15.0	15.0	
134	(132, 136)	15.0	15.0	15.0
136		15.0	15.0	
140		15.0	15.0	
149		20.0	20.0	
151	(149, 153)			20.0

20 MHZ CHANNEL	40 MHZ CHANNEL	LEGACY OFDM RATES (6,9,12,18,24,36,48,54 MBPS)	802.11n HT20 RATES (MCS 0 MCS 15)	802.11n HT40 RATES (MCS 0 MCS 15)
153		20.0	20.0	
157		20.0	20.0	
159	(157, 161)	20.0	20.0	20.0
161		20.0	20.0	
165		20.0	20.0	

Panel antenna, peak gain = 10.5dBi

19.2.4 Patch Antenna Model

The following is a transmit power table (US domain) per patch antenna in the 5 GHz band:

20 MHZ CHANNEL	40 MHZ CHANNEL	LEGACY OFDM RATES (6,9,12,18,24,36,48,54 MBPS)	802.11n HT20 RATES (MCS 0 MCS 15)	802.11n HT40 RATES (MCS 0 MCS 15)
36		15.0	15.0	
38	(36, 40)	15.0	15.0	13.0
40		15.0	15.0	
44		15.0	15.0	
46	(44, 48)	15.0	15.0	13.0
48		15.0	15.0	
52		15.0	15.0	
54	(52, 56)	15.0	15.0	13.0
56		15.0	15.0	
60		15.0	15.0	
62	(60, 64)	15.0	15.0	20.0
64		15.0	15.0	
100		20.0	20.0	
102	(100, 104)	20.0	20.0	20.0
104		20.0	20.0	
108		20.0	20.0	
110		20.0	20.0	20.0
112	(108, 112)	20.0	20.0	
116		20.0	20.0	
118	(116, 120)	20.0	20.0	20.0
120		20.0	20.0	
124		20.0	20.0	
126	(124, 128)	20.0	20.0	20.0
128		20.0	20.0	
132		20.0	20.0	
134	(132, 136)	20.0	20.0	20.0
136		20.0	20.0	
140		20.0	20.0	
149		20.0	20.0	
151	(149, 153)	20.0	20.0	20.0

20 MHZ CHANNEL	40 MHZ CHANNEL	LEGACY OFDM RATES (6,9,12,18,24,36,48,54 MBPS)	802.11n HT20 RATES (MCS 0 MCS 15)	802.11n HT40 RATES (MCS 0 MCS 15)
153		20.0	20.0	
157		20.0	20.0	
159	(157, 161)	20.0	20.0	20.0
161		20.0	20.0	
165		20.0	20.0	

Patch antenna, peak gain = 3.8dBi

19.2.5 External Facade Antenna Model

The following is a transmit power table (US domain) per external facade antenna in the 5 GHz band:

20 MHZ CHANNEL	40 MHZ CHANNEL	LEGACY OFDM RATES (6,9,12,18,24,36,48,54 MBPS)	802.11n HT20 RATES (MCS 0 MCS 15)	802.11n HT40 RATES (MCS 0 MCS 15)
36		14.0	14.0	
38	(36, 40)	14.0	14.0	14.0
40		14.0	14.0	
44		14.0	14.0	
46	(44, 48)	14.0	14.0	14.0
48		14.0	14.0	
52		15.0	15.0	
54	(52, 56)	15.0	15.0	15.0
56		15.0	15.0	
60		15.0	15.0	
62	(60, 64)	15.0	15.0	15.0
64		15.0	15.0	
100		20.0	20.0	
102	(100, 104)	20.0	20.0	20.0
104		20.0	20.0	
108		20.0	20.0	
110		20.0	20.0	20.0
112	(108, 112)	20.0	20.0	
116		20.0	20.0	
118	(116, 120)	20.0	20.0	20.0
120		20.0	20.0	
124		20.0	20.0	
126	(124, 128)	20.0	20.0	20.0
128		20.0	20.0	
132		20.0	20.0	
134	(132, 136)	20.0	20.0	20.0
136		20.0	20.0	
140		20.0	20.0	
149		20.0	20.0	
151	(149, 153)	20.0	20.0	20.0

20 MHZ CHANNEL	40 MHZ CHANNEL	LEGACY OFDM RATES (6,9,12,18,24,36,48,54 MBPS)	802.11n HT20 RATES (MCS 0 MCS 15)	802.11n HT40 RATES (MCS 0 MCS 15)
153		20.0	20.0	
157		20.0	20.0	
159	(157, 161)	20.0	20.0	20.0
161		20.0	20.0	
165		20.0	20.0	

External facade antenna, peak gain = 4.0dBi

19.3 EU Regulatory Domain 2.4 GHz Band

19.3.1 External Dipole Antenna Model

The following is a transmit power table (EU domain) per external dipole antenna in the 2.4 GHz band:

20 MHZ CHANNEL	40 MHZ CHANNEL	LEGACY DSSS RATES (1, 2, 5.5, 11 MBPS)	LEGACY OFDM RATES (6,9,12,18,24,36, 48,54 MBPS)	802.11n HT20 RATES (MCS 0 MCS 15)	802.11n HT40 RATES (MCS 0 MCS15)
1		4.5	4.5	4.5	
2		4.5	4.5	4.5	
3	(1, 5)	4.5	4.5	4.5	4.5
4	(2, 6)	4.5	4.5	4.5	4.5
5	(3, 7)	4.5	4.5	4.5	4.5
6	(4, 8)	4.5	4.5	4.5	4.5
7	(5, 9)	4.5	4.5	4.5	4.5
8	(6, 10)	4.5	4.5	4.5	4.5
9	(7, 11)	4.5	4.5	4.5	4.5
10	(8, 12)	4.5	4.5	4.5	4.5
11	(9, 13)	4.5	4.5	4.5	4.5
12		4.5	4.5	4.5	
13		4.5	4.5	4.5	
14					

External dipole antenna, peak gain = 10.5dBi

19.3.2 External Panel Antenna Model

The following is a transmit power table (EU domain) per external panel antenna in the 2.4 GHz band:

20 MHZ CHANNEL	40 MHZ CHANNEL	LEGACY DSSS RATES (1, 2, 5.5, 11 MBPS)	LEGACY OFDM RATES (6,9,12,18,24,36, 48,54 MBPS)	802.11n HT20 RATES (MCS 0 MCS 15)	802.11n HT40 RATES (MCS 0 MCS15)
1		7.0	7.0	7.0	
2		7.0	7.0	7.0	
3	(1, 5)	7.0	7.0	7.0	7.0
4	(2, 6)	7.0	7.0	7.0	7.0
5	(3, 7)	7.0	7.0	7.0	7.0
6	(4, 8)	7.0	7.0	7.0	7.0
7	(5, 9)	7.0	7.0	7.0	7.0
8	(6, 10)	7.0	7.0	7.0	7.0
9	(7, 11)	7.0	7.0	7.0	7.0
10	(8, 12)	7.0	7.0	7.0	7.0
11	(9, 13)	7.0	7.0	7.0	7.0
12		7.0	7.0	7.0	
13		7.0	7.0	7.0	
14					

External panel antenna, peak gain = 8dBi

19.3.3 External Patch Antenna Model

The following is a transmit power table (EU domain) per external patch antenna in the 2.4 GHz band:

20 MHZ CHANNEL	40 MHZ CHANNEL	LEGACY DSSS RATES (1, 2, 5.5, 11 MBPS)	LEGACY OFDM RATES (6,9,12,18,24,36, 48,54 MBPS)	802.11n HT20 RATES (MCS 0 MCS 15)	802.11n HT40 RATES (MCS 0 MCS15)
1		11.0	11.0	11.0	
2		11.0	11.0	11.0	
3	(1, 5)	11.0	11.0	11.0	11.0
4	(2, 6)	11.0	11.0	11.0	11.0
5	(3, 7)	11.0	11.0	11.0	11.0
6	(4, 8)	11.0	11.0	11.0	11.0
7	(5, 9)	11.0	11.0	11.0	11.0
8	(6, 10)	11.0	11.0	11.0	11.0
9	(7, 11)	11.0	11.0	11.0	11.0
10		11.0	11.0	11.0	
11		11.0	11.0	11.0	
12					
13					
14					

External patch antenna, peak gain = 4dBi

19.3.4 Internal Facade Antenna Model

The following is a transmit power table (EU domain) per internal facade antenna in the 2.4 GHz band:

20 MHZ CHANNEL	40 MHZ CHANNEL	LEGACY DSSS RATES (1, 2, 5.5, 11 MBPS)	LEGACY OFDM RATES (6,9,12,18,24,36, 48,54 MBPS)	802.11n HT20 RATES (MCS 0 MCS 15)	802.11n HT40 RATES (MCS 0 MCS15)
1		11.5	11.5	11.5	
2		11.5	11.5	11.5	
3	(1, 5)	11.5	11.5	11.5	10.5
4	(2, 6)	11.5	11.5	11.5	11.5
5	(3, 7)	11.5	11.5	11.5	11.5
6	(4, 8)	11.5	11.5	11.5	11.5
7	(5, 9)	11.5	11.5	11.5	11.5
8	(6, 10)	11.5	11.5	11.5	11.5
9	(7, 11)	11.5	11.5	11.5	11.5
10		11.5	11.5	11.5	
11		11.5	11.5	11.5	
12					
13					
14					

Internal facade antenna, peak gain = 3.5dBi

19.4 EU Regulatory Domain 5 GHz Band

19.4.1 External Dipole Antenna Model

The following is a transmit power table (EU domain) per external dipole antenna in the 5 GHz band:

20 MHZ CHANNEL	40 MHZ CHANNEL	LEGACY OFDM RATES (6,9,12,18,24,36,48,54 MBPS)	802.11n HT20 RATES (MCS 0 MCS 15)	802.11n HT40 RATES (MCS 0 MCS 15)
36		7.5	7.5	
38	(36, 40)	7.5	7.5	7.5
40		7.5	7.5	
44		7.5	7.5	
46	(44, 48)	7.5	7.5	7.5
48		7.5	7.5	
52		4.5	4.5	
54	(52, 56)	4.5	4.5	4.5
56		4.5	4.5	
60		4.5	4.5	
62	(60, 64)	4.5	4.5	4.5
64		4.5	4.5	
100		11.5	11.5	
102	(100, 104)	11.5	11.5	11.5
104		11.5	11.5	
108		11.5	11.5	
110		11.5	11.5	11.5
112	(108, 112)	11.5	11.5	
116		11.5	11.5	
118	(116, 120)	11.5	11.5	11.5
120		11.5	11.5	
124		11.5	11.5	
126	(124, 128)	11.5	11.5	11.5
128		11.5	11.5	
132		11.5	11.5	
134	(132, 136)	11.5	11.5	11.5
136		11.5	11.5	
140		11.5	11.5	
149				

20 MHZ CHANNEL	40 MHZ CHANNEL	LEGACY OFDM RATES (6,9,12,18,24,36,48,54 MBPS)	802.11n HT20 RATES (MCS 0 MCS 15)	802.11n HT40 RATES (MCS 0 MCS 15)
151	(149, 153)			
153				
157				
159	(157, 161)			
161				
165				

External dipole antenna, peak gain = 10.5dBi

19.4.2 External Panel Antenna Model

The following is a transmit power table (EU domain) per external panel antenna in the 5 GHz band:

20 MHZ CHANNEL	40 MHZ CHANNEL	LEGACY OFDM RATES (6,9,12,18,24,36,48,54 MBPS)	802.11n HT20 RATES (MCS 0 MCS 15)	802.11n HT40 RATES (MCS 0 MCS 15)
36		4.0	4.0	
38	(36, 40)	4.0	4.0	4.0
40		4.0	4.0	
44		4.0	4.0	
46	(44, 48)	4.0	4.0	4.0
48		4.0	4.0	
52		1.0	1.0	
54	(52, 56)	1.0	1.0	1.0
56		1.0	1.0	
60		1.0	1.0	
62	(60, 64)	1.0	1.0	1.0
64		1.0	1.0	
100		8.0	11.5	
102	(100, 104)	8.0	8.0	8.0
104		8.0	8.0	
108		8.0	8.0	
110		8.0	8.0	8.0
112	(108, 112)	8.0	8.0	
116		8.0	8.0	
118	(116, 120)	8.0	8.0	8.0
120		8.0	8.0	
124		8.0	8.0	
126	(124, 128)	8.0	8.0	8.0
128		8.0	8.0	
132		8.0	8.0	
134	(132, 136)	8.0	8.0	8.0
136		8.0	8.0	
140		8.0	8.0	
149				
151	(149, 153)			

20 MHZ CHANNEL	40 MHZ CHANNEL	LEGACY OFDM RATES (6,9,12,18,24,36,48,54 MBPS)	802.11n HT20 RATES (MCS 0 MCS 15)	802.11n HT40 RATES (MCS 0 MCS 15)
153				
157				
159	(157, 161)			
161				
165				

External panel antenna, peak gain = 14dBi

19.4.3 External Yagi Antenna Model

The following is a transmit power table (EU domain) per external yagi antenna in the 5 GHz band:

20 MHZ CHANNEL	40 MHZ CHANNEL	LEGACY OFDM RATES (6,9,12,18,24,36,48,54 MBPS)	802.11n HT20 RATES (MCS 0 MCS 15)	802.11n HT40 RATES (MCS 0 MCS 15)
36		7.5	6.0	
38	(36, 40)	7.5	7.5	7.5
40		7.5	7.5	
44		7.5	7.5	
46	(44, 48)	7.5	7.5	7.5
48		7.5	7.5	
52		4.5	4.5	
54	(52, 56)	4.5	4.5	4.5
56		4.5	4.5	
60		4.5	4.5	
62	(60, 64)	4.5	4.5	4.5
64		4.5	4.5	
100		11.5	11.5	
102	(100, 104)	11.5	11.5	11.5
104		11.5	11.5	
108		11.5	11.5	
110		11.5	11.5	11.5
112	(108, 112)	11.5	11.5	
116		11.5	11.5	
118	(116, 120)	11.5	11.5	11.5
120		11.5	11.5	
124		11.5	11.5	
126	(124, 128)	11.5	11.5	11.5
128		11.5	11.5	
132		11.5	11.5	
134	(132, 136)	11.5	11.5	11.5
136		11.5	11.5	
140		11.5	11.5	
149				
151	(149, 153)			

20 MHZ CHANNEL	40 MHZ CHANNEL	LEGACY OFDM RATES (6,9,12,18,24,36,48,54 MBPS)	802.11n HT20 RATES (MCS 0 MCS 15)	802.11n HT40 RATES (MCS 0 MCS 15)
153				
157				
159	(157, 161)			
161				
165				

External yagi antenna, peak gain = 10.5dBi

19.4.4 External Patch Antenna Model

The following is a transmit power table (EU domain) per external patch antenna in the 5 GHz band:

20 MHZ CHANNEL	40 MHZ CHANNEL	LEGACY OFDM RATES (6,9,12,18,24,36,48,54 MBPS)	802.11n HT20 RATES (MCS 0 MCS 15)	802.11n HT40 RATES (MCS 0 MCS 15)
36		14.0	14.0	
38	(36, 40)	14.0	14.0	14.0
40		14.0	14.0	
44		14.0	14.0	
46	(44, 48)	14.0	14.0	14.0
48		14.0	14.0	
52		11.0	11.0	
54	(52, 56)	11.0	11.0	11.0
56		11.0	11.0	
60		11.0	11.0	
62	(60, 64)	11.0	11.0	11.0
64		11.0	11.0	
100		18.0	18.0	
102	(100, 104)	18.0	18.0	18.0
104		18.0	18.0	
108		18.0	18.0	
110		18.0	18.0	18.0
112	(108, 112)	18.0	18.0	
116		18.0	18.0	
118	(116, 120)	18.0	18.0	18.0
120		18.0	18.0	
124		18.0	18.0	
126	(124, 128)	18.0	18.0	18.0
128		18.0	18.0	
132		18.0	18.0	
134	(132, 136)	18.0	18.0	18.0
136		18.0	18.0	
140		18.0	18.0	
149				
151	(149, 153)			

20 MHZ CHANNEL	40 MHZ CHANNEL	LEGACY OFDM RATES (6,9,12,18,24,36,48,54 MBPS)	802.11n HT20 RATES (MCS 0 MCS 15)	802.11n HT40 RATES (MCS 0 MCS 15)
153				
157				
159	(157, 161)			
161				
165				

External patch antenna, peak gain = 3.8dBi

19.4.5 External Facade Antenna Model

The following is a transmit power table (EU domain) per external facade antenna in the 5 GHz band:

20 MHZ CHANNEL	40 MHZ CHANNEL	LEGACY OFDM RATES (6,9,12,18,24,36,48,54 MBPS)	802.11n HT20 RATES (MCS 0 MCS 15)	802.11n HT40 RATES (MCS 0 MCS 15)
36		14.0	14.0	
38	(36, 40)	14.0	14.0	14.0
40		14.0	14.0	
44		14.0	14.0	
46	(44, 48)	14.0	14.0	14.0
48		14.0	14.0	
52		11.0	11.0	
54	(52, 56)	11.0	11.0	11.0
56		11.0	11.0	
60		11.0	11.0	
62	(60, 64)	11.0	11.0	11.0
64		11.0	11.0	
100		18.0	18.0	
102	(100, 104)	18.0	18.0	18.0
104		18.0	18.0	
108		18.0	18.0	
110		18.0	18.0	18.0
112	(108, 112)	18.0	18.0	
116		18.0	18.0	
118	(116, 120)	18.0	18.0	18.0
120		18.0	18.0	
124		18.0	18.0	
126	(124, 128)	18.0	18.0	18.0
128		18.0	18.0	
132		18.0	18.0	
134	(132, 136)	18.0	18.0	18.0
136		18.0	18.0	
140		18.0	18.0	
149				
151	(149, 153)			

20 MHZ CHANNEL	40 MHZ CHANNEL	LEGACY OFDM RATES (6,9,12,18,24,36,48,54 MBPS)	802.11n HT20 RATES (MCS 0 MCS 15)	802.11n HT40 RATES (MCS 0 MCS 15)
153				
157				
159	(157, 161)			
161				
165				

External facade antenna, peak gain = 4dBi



Technical Support

Comprehensive on-line support is available at the Support Central site at <http://supportcentral.motorola.com/>. Support Central provides our customers with a wealth of information and online assistance including developer tools, software downloads, product manuals and online repair requests.

When contacting the Support Center, please provide the following information:

- *serial number of unit*
- *model number or product name*
- *software type and version number.*

Web Support Sites

Product Downloads

<http://supportcentral.motorola.com/support/product/softwaredownloads.do>

Manuals

<http://supportcentral.motorola.com/support/product/manuals.do>

Additional Information

Obtain additional information by contacting Motorola Solutions at:

1-800-722-6234, inside North America

+1-516-738-5200, in/outside North America

<http://www.motorolasolutions.com/>

MOTOROLA SOLUTIONS INC.
1303 E. ALGONQUIN ROAD
SCHAUMBURG, IL 60196
<http://www.motorolasolutions.com>

72E-162906-01 Revision B
July 2012