



Installing the Virtual Services Platform 8000 Series

Installing the VSP 8000 Series

Copyright © 2017-2021 Extreme Networks, Inc.

Table of Contents

Legal Notices.....	4
Chapter 1: About this Document.....	5
Purpose.....	5
Conventions.....	5
Documentation and Training.....	7
Getting Help.....	7
Providing Feedback.....	8
Chapter 2: New in this document.....	9
Chapter 3: Hardware models for VSP 8000 Series.....	10
Power cord types and order codes.....	14
Chapter 4: Preinstallation checklist.....	16
Chapter 5: Installing the Virtual Services Platform 8000 Series.....	17
Installation checklist.....	17
Installation fundamentals.....	18
Ethernet Switch Module.....	21
Electrostatic discharge.....	30
Technical specifications.....	32
Package contents.....	34
Installing the VSP 8000 Series in an Equipment Rack.....	34
Cable requirements for the VSP 8000 Series.....	69
Installation and removal of transceivers.....	70
Console port pin assignments.....	70
AC Power Supply.....	71
DC Power Supply.....	75
Removing a power supply.....	79
Airflow direction.....	79
Install a Fan Module.....	79
LED state definitions.....	81
40GBASE-QSFP+ ports.....	86
MACsec operational notes.....	86
Viewing hardware information.....	86
Chapter 6: Translations of safety messages.....	89

Legal Notices

Legal Notice

Extreme Networks, Inc. reserves the right to make changes in specifications and other information contained in this document and its website without prior notice. The reader should in all cases consult representatives of Extreme Networks to determine whether any such changes have been made.

The hardware, firmware, software or any specifications described or referred to in this document are subject to change without notice.

Trademarks

Extreme Networks and the Extreme Networks logo are trademarks or registered trademarks of Extreme Networks, Inc. in the United States and/or other countries.

All other names (including any product names) mentioned in this document are the property of their respective owners and may be trademarks or registered trademarks of their respective companies/owners.

For additional information on Extreme Networks trademarks, see: www.extremenetworks.com/company/legal/trademarks

Open Source Declarations

Some software files have been licensed under certain open source or third-party licenses. End-user license agreements and open source declarations can be found at: <https://www.extremenetworks.com/support/policies/open-source-declaration/>

1 About this Document

Purpose
Conventions
Documentation and Training
Getting Help
Providing Feedback

This section discusses the purpose of this document, the conventions used, ways to provide feedback, additional help, and information regarding other Extreme Networks publications.

Purpose

This guide provides information and instructions to install the Extreme Networks Virtual Services Platform 8000 Series (VSP 8000 Series) switches. The VSP 8000 Series includes the VSP 8200 Series and the VSP 8400 Series.

Conventions

This section discusses the conventions used in this guide.

Text Conventions

The following tables list text conventions that can be used throughout this document.

Table 1: Notes and warnings




Icon	Notice type	Alerts you to...
	Tip	Helpful tips and notices for using the product.
	Note	Useful information or instructions.
	Important	Important features or instructions.

Table 1: Notes and warnings (continued)



Icon	Notice type	Alerts you to...
	Caution	Risk of personal injury, system damage, or loss of data.
	Warning	Risk of severe personal injury.

Table 2: Text Conventions

Convention	Description
Angle brackets (< >)	Angle brackets (< >) indicate that you choose the text to enter based on the description inside the brackets. Do not type the brackets when you enter the command. If the command syntax is <code>cfm maintenance-domain maintenance-level <0-7></code> , you can enter <code>cfm maintenance-domain maintenance-level 4</code> .
Bold text	Bold text indicates the GUI object name you must act upon. Examples: <ul style="list-style-type: none"> Click OK. On the Tools menu, choose Options.
Braces ({ })	Braces ({ }) indicate required elements in syntax descriptions. Do not type the braces when you enter the command. For example, if the command syntax is <code>ip address {A.B.C.D}</code> , you must enter the IP address in dotted, decimal notation.
Brackets ([])	Brackets ([]) indicate optional elements in syntax descriptions. Do not type the brackets when you enter the command. For example, if the command syntax is <code>show clock [detail]</code> , you can enter either <code>show clock</code> or <code>show clock detail</code> .
Ellipses (...)	An ellipsis (...) indicates that you repeat the last element of the command as needed. For example, if the command syntax is <code>ethernet/2/1 [<parameter> <value>]...</code> , you enter <code>ethernet/2/1</code> and as many parameter-value pairs as you need.
Italic Text	Italics emphasize a point or denote new terms at the place where they are defined in the text. Italics are also used when referring to publication titles that are not active links.

Table 2: Text Conventions (continued)

Convention	Description
Plain Courier Text	Plain Courier text indicates command names, options, and text that you must enter. Plain Courier text also indicates command syntax and system output, for example, prompts and system messages. Examples: <ul style="list-style-type: none"> • <code>show ip route</code> • <code>Error: Invalid command syntax [Failed] [2013-03-22 13:37:03.303 -04:00]</code>
Separator (>)	A greater than sign (>) shows separation in menu paths. For example, in the Navigation tree, expand the Configuration > Edit folders.
Vertical Line ()	A vertical line () separates choices for command keywords and arguments. Enter only one choice. Do not type the vertical line when you enter the command. For example, if the command syntax is <code>access-policy by-mac action { allow deny }</code> , you enter either <code>access-policy by-mac action allow</code> or <code>access-policy by-mac action deny</code> , but not both.

Documentation and Training

Find Extreme Networks product information at the following locations:

- [Current Product Documentation](#)
- [Release Notes](#)
- [Hardware/software compatibility matrices](#) for Campus and Edge products
- [Supported transceivers and cables](#) for Data Center products
- [Other resources](#), like white papers, data sheets, and case studies

Extreme Networks offers product training courses, both online and in person, as well as specialized certifications. For details, visit www.extremenetworks.com/education/.

Getting Help

If you require assistance, contact Extreme Networks using one of the following methods:

- Extreme Portal** Search the GTAC (Global Technical Assistance Center) knowledge base; manage support cases and service contracts; download software; and obtain product licensing, training, and certifications.
- The Hub** A forum for Extreme Networks customers to connect with one another, answer questions, and share ideas and feedback. This community is monitored by Extreme Networks employees, but is not intended to replace specific guidance from GTAC.

Call GTAC For immediate support: (800) 998 2408 (toll-free in U.S. and Canada) or 1 (408) 579 2826. For the support phone number in your country, visit: www.extremenetworks.com/support/contact

Before contacting Extreme Networks for technical support, have the following information ready:

- Your Extreme Networks service contract number, or serial numbers for all involved Extreme Networks products
- A description of the failure
- A description of any actions already taken to resolve the problem
- A description of your network environment (such as layout, cable type, other relevant environmental information)
- Network load at the time of trouble (if known)
- The device history (for example, if you have returned the device before, or if this is a recurring problem)
- Any related RMA (Return Material Authorization) numbers

Subscribe to Service Notifications

You can subscribe to email notifications for product and software release announcements, Vulnerability Notices, and Service Notifications.

- 1 Go to www.extremenetworks.com/support/service-notification-form.
- 2 Complete the form (all fields are required).
- 3 Select the products for which you would like to receive notifications.



Note

You can modify your product selections or unsubscribe at any time.

- 4 Select **Submit**.

Providing Feedback

The Information Development team at Extreme Networks has made every effort to ensure the accuracy and completeness of this document. We are always striving to improve our documentation and help you work better, so we want to hear from you. We welcome all feedback, but we especially want to know about:

- Content errors, or confusing or conflicting information.
- Improvements that would help you find relevant information in the document.
- Broken links or usability issues.

If you would like to provide feedback, you can do so in three ways:

- In a web browser, select the feedback icon and complete the online feedback form.
- Access the feedback form at <https://www.extremenetworks.com/documentation-feedback/>.
- Email us at documentation@extremenetworks.com.

Provide the publication title, part number, and as much detail as possible, including the topic heading and page number if applicable, as well as your suggestions for improvement.

2 New in this document

Temperature Sensors

The following section details what is new in this document.

Warning and critical threshold values are updated in the document. For more information, see [Install a Fan Module](#) on page 79.

3 Hardware models for VSP 8000 Series

Power cord types and order codes

This section lists the VSP 8000 Series hardware.

VSP 8200 Series Hardware

Power cords must be ordered separately. Ensure you order the correct power cord for your region. For more information, see [Power cord types and order codes](#).

Table 3: VSP 8284XSQ Hardware

VSP 8284XSQ	Description	Part number
VSP 8284XSQ-AC This model number ships with one field-replaceable 800 watt AC power supply.	<ul style="list-style-type: none"> • 80 ports of 10GBASE-SFP+ • 4 ports of 40GBASE-QSFP+ • one 10/100/1000BASE-T Out-Of-Band Management Port • one RJ-45 Console Port • one USB 2.0 port • Base Software License • four field-replaceable fan modules 	EC8200A01-E6
VSP 8284XSQ-DC This model number ships with one field-replaceable 800 watt DC power supply.	Includes all of the above features.	— Effective 12-Jun-2017, the DC version of the VSP 8284XSQ switch is no longer being sold.
VSP 8284XSQ AC PS No PC GSA This model number is compliant with the Trade Agreements Act (TAA). It ships with one field-replaceable 800 watt AC power supply but no power cord.	Includes all of the above features.	EC8200A01-E6GS
Redundant power supplies		
800 watt AC redundant power supply	<ul style="list-style-type: none"> • The VSP 8284XSQ comes with one 800 W AC PSU. • For full power redundancy, you can install a second 800 W AC PSU. 	EC8005A01-E6
800 watt DC redundant power supply	<ul style="list-style-type: none"> • The VSP 8284XSQ comes with one 800 W DC PSU. • For full power redundancy, you can install a second 800 W DC PSU. 	EC8005001-E6

Table 3: VSP 8284XSQ Hardware (continued)

VSP 8284XSQ	Description	Part number
Redundant fan modules		
12 volt redundant fan module	The VSP 8284XSQ comes with all four 12-V fan modules installed.	EC8011004-E6
Universal Slide Rack Mount Kit (300mm-900mm)		
Slide Rack Mount Kit (300mm-900mm)	The optional rack mount kit allows a switch to be installed in a four post rack with depths between 300mm and 900mm. It is designed for use on the VSP 7200 Series, VSP 8200 Series and VSP 8400 Series.	EC8011002-E6
<p>Note:</p> <p>The universal slide rack mount kit is optional and must be ordered separately. VSP 7200 Series, VSP 8200 Series and VSP 8400 Series ship with rack mount brackets. When using rack mount brackets on the VSP 8200 Series and VSP 8400 Series, we recommend the use of a shelf to provide additional support.</p>		

VSP 8400 Series hardware

The following tables describe the VSP 8400 Series hardware.

Table 4: VSP 8404 Hardware

VSP 8404	Description	Part number
VSP 8404 AC This model number ships with one field-replaceable 800 watt AC power supply.	<ul style="list-style-type: none"> one 10/100/1000BASE-T Out-Of-Band Management Port one RJ-45 Console Port one USB 2.0 port Base Software License four field-replaceable fan modules 	EC8400A01-E6
VSP 8404 AC PS No PC GSA This model number is compliant with the Trade Agreements Act (TAA). It ships with one field-replaceable 800 watt AC power supply but no power cord.	Includes all of the above components.	EC8400A01-E6GS
VSP 8404C AC This model number ships with one field-replaceable 800 watt AC power supply.	Includes all of the above components.	EC8400A02-E6
VSP 8404C-AC No PC GSA This model is TAA compliant. It ships with an AC power supply but no power cord.	Includes all of the above components.	EC8400A02-E6GS
VSP 8404-DC This model number ships with one field-replaceable 800 watt DC power supply.	Includes all of the above components.	EC8400001-E6

Table 4: VSP 8404 Hardware (continued)

VSP 8404	Description	Part number
VSP 8404C-DC This model number ships with one field-replaceable 800 watt DC power supply.	Includes all of the above components.	EC8400002-E6
Redundant power supplies		
800 watt AC redundant power supply	<ul style="list-style-type: none"> The VSP 8400 Series comes with one 800 W AC PSU. For full power redundancy, you can install a second 8001-AC-PSU. No power cord. 	EC8005A01-E6
800 watt DC redundant power supply	<ul style="list-style-type: none"> The VSP 8400 Series comes with one 800 W DC PSU. For full power redundancy, you can install a second 800 W DC PSU. 	EC8005001-E6
Spare fan modules		
Spare fan module	The VSP 8404 comes with all four 12-V fan modules installed. This part can be purchased if a spare fan module is desired.	EC8011005-E6
Universal Slide Rack Mount Kit (300mm-900mm)		
Slide Rack Mount Kit (300mm-900mm)	The optional rack mount kit allows a switch to be installed in a four post rack with depths between 300mm and 900mm. It is designed for use on the VSP 7200 Series, VSP 8200 Series and VSP 8400 Series.	EC8011002-E6
<p>Note: The universal slide rack mount kit is optional and must be ordered separately. The VSP 7200 Series, VSP 8200 Series and VSP 8400 Series ship with rack mount brackets. When using rack mount brackets on the VSP 8200 Series and VSP 8400 Series, we recommend the use of a shelf to provide additional support.</p>		

Table 5: VSP 8400 Series Ethernet switch modules (ESMs)

Model Name	Description	Part Number
8424XS	24 port 10GBASE-SFP+ Ethernet Switch Module	EC8404001-E6
8424XS (TAA-compliant)	24 port 10GBASE-SFP+ Ethernet Switch Module	EC8404001-E6GS
8424XT	24 port 10GBASE-T Ethernet Switch Module	EC8404002-E6
8424XT (TAA-compliant)	24 port 10GBASE-T Ethernet Switch Module	EC8404002-E6GS
8408QQ	8 port 40GBASE-QSFP+ Ethernet Switch Module	EC8404003-E6
<p>Note: Two ports are reserved for future use.</p>		

Table 5: VSP 8400 Series Ethernet switch modules (ESMs) (continued)

Model Name	Description	Part Number
8408QQ (TAA-compliant)	8 port 40GBASE-QSFP+ Ethernet Switch Module	EC8404003-E6GS
Note: Two ports are reserved for future use.		
8418XSQ	16 port 10GBASE-SFP+ and 2 port 40GBASE-QSFP + Combination Ethernet Switch Module	EC8404005-E6
8418XSQ (TAA-compliant)	16 port 10GBASE-SFP+ and 2 port 40GBASE-QSFP + Combination Ethernet Switch Module	EC8404005-E6GS
8418XTQ	16 port 10GBASE-T and 2 port 40GBASE-QSFP+ Combination Ethernet Switch Module	EC8404006-E6
8418XTQ (TAA-compliant)	16 port 10GBASE-T and 2 port 40GBASE-QSFP+ Combination Ethernet Switch Module	EC8404006-E6GS
8424GS	24 port 100/1000BASE-X Ethernet Switch Module	EC8404007-E6
8424GS (TAA-compliant)	24 port 100/1000BASE-X Ethernet Switch Module	EC8404007-E6GS
8424GT	24 port 10/100/1000BASE-T Ethernet Switch Module	EC8404008-E6
8424GT (TAA-compliant)	24 port 10/100/1000BASE-T Ethernet Switch Module	EC8404008-E6GS
8402CQ	2 port 100G QSFP28 Ethernet Switch Module	EC8404009-E6
Important: This ESM operates only with the VSP 8404C model.		
8402CQ (TAA-compliant)	2 port 100G QSFP28 Ethernet Switch Module	EC8404009-E6GS
Important: This ESM operates only with the VSP 8404C model.		

Compatible transceivers

Important

We recommend using the SFP, SFP+, QSFP+, and QSFP28 transceivers as they have been through extensive qualification and testing. Extreme Networks will not be responsible for issues related to third party transceivers.



- The VSP 8000 Series operates in forgiving mode for SFP, SFP+, and QSFP+ transceivers, which means that the switch will bring up the port operationally when using third party transceivers (SFP, SFP+ or QSFP+). Extreme Networks does not provide support for operational issues related to these transceivers, but they will operate and the port link will come up. The switch logs the device as an unsupported or unknown device.

For more information about compatible transceivers, see [Extreme Networks Pluggable Transceivers Installation Guide](#) and [Extreme Hardware/Software Compatibility and Recommendation Matrices](#).

VSP 8000 Series operational notes

The VSP 8000 Series supports channelization of a 40 Gbps port into four 10 Gbps channelized interfaces for the following ports:

- The VSP 8200 Series supports channelization on all four 40 Gbps ports.
- The VSP 8400 Series supports channelization on the following ESM ports:
 - The two 40 Gbps ports of the 8418XSQ.
 - The two 40 Gbps ports of the 8418XTQ.
 - The first six 40 Gbps ports of the 8408QQ.

Note



- Channelized port operation is not affected when the same ESM type is hot swapped when one or more 40 Gbps ports on that ESM are channelized. Swapping a different ESM results in the configuration for that slot being lost, so any channelized ports need to be re-configured.
- 8402CQ 100 Gbps ESM does not support channelization.

Power cord types and order codes

To connect AC power to the switch, you need an appropriate AC power cord as described in the following table.

Table 6: Power cords for power distribution units

Order Code	Length	Power supply side connector	Power source side connector	Safety Approval
700512239	3 m	C13	C14	USA
700512241	3 m	C13	C14	International except Japan and Taiwan

Table 7: Power Cords with C14 power supply side connector

Order Code	Description	Region
AA0020062E6	Power cord 3.05 m IEC C13 to NEMA 5-15P	North America
AA0020063E6	Power cord 2.5 m IEC C13 to BS1363	United Kingdom
AA0020064E6	Power cord 2.5 m IEC C13 to CEE 7/7	European Union
AA0020065E6	Power cord 2.5 m IEC C13 to CEI 23-16	Italy
AA0020066E6	Power cord 2.5 m IEC C13 to GB 2099.1-1996	China
AA0020067E6	Power cord 2.5 m IEC C13 to BS-546/SANS164-1	India & South Africa
AA0020068E6	Power cord 2.5 m IEC C13 to AS 3112	Australia
AA0020069E6	Power cord 2.5 m IEC C13 to JIS 8303	Japan
AA0020101-E6	Power cord 2.5 m IEC C13 to NBR 14136 (IEC 60906-1)	Brazil
AA0020104-E6	Power cord 2.5 m IEC C13 to SEV 1011	Switzerland
AA0020107-E6	Power cord 2.5 m IEC C13 to SI-32	Israel

4 Preinstallation checklist

Before you install the VSP 8000 Series, make sure that you complete the tasks in the preinstallation checklist.

No.	Task	Description	✓
1.	Review the technical specification for the switch. Make sure that the area where you install the switch and where it will operate meet the requirements.	For the physical, electrical, and environmental specifications, see Technical specifications .	
2.	Verify the power supply unit (PSU) specifications. Optionally order a redundant PSU to provide redundancy and load sharing.	See AC power supply specifications or DC power supply specifications .	
3.	Make sure that you have the following tools and cables: <ul style="list-style-type: none">• Phillips #2 screwdriver• RJ-45 console port cable• ESD cable	See Cable requirements for the VSP 8000 Series on page 69.	
4.	Unpack the equipment.	Observe ESD precautions when you unpack the equipment. See Electrostatic discharge .	
5.	Verify the contents of the shipped package.	See Package contents for a description of the components that are provided with the switch. If any components are missing, contact Extreme Networks support.	
6.	Make sure that the power cord has the correct country-specific termination.		
7.	Prepare the rack.	Ensure that there is enough rack space to accommodate a 2RU switch (8.8 cm). Ensure that the rack is bolted to the floor and braced if necessary. Ensure that the rack is grounded to the same grounding electrode used by the power service in the area. The ground path must be permanent and must not exceed 1 Ohm of resistance from the rack to the grounding electrode.	

5 Installing the Virtual Services Platform 8000 Series

Installation checklist
Installation fundamentals
Ethernet Switch Module
Electrostatic discharge
Technical specifications
Package contents
Installing the VSP 8000 Series in an Equipment Rack
Cable requirements for the VSP 8000 Series
Installation and removal of transceivers
Console port pin assignments
AC Power Supply
DC Power Supply
Removing a power supply
Airflow direction
Install a Fan Module
LED state definitions
40GBASE-QSFP+ ports
MACsec operational notes
Viewing hardware information

This section provides the information and procedures to install the VSP 8000 Series.

Installation checklist

Use this checklist to install the VSP 8000 Series.

No.	Task	Description	✓
1.	Mount the VSP 8000 Series switch in the equipment rack.	See Installing the VSP 8000 Series in an Equipment Rack on page 34. You have two options for installing the switch in an equipment rack: <ul style="list-style-type: none"> • Using the optional slide rack mount kit • Using the supplied brackets on page 67 	
2.	Install the primary or redundant power supply. Important: A combination of AC-input and DC-input power supplies in the same chassis is not supported.	If you have an AC power supply, see Installing an AC power supply on page 71. If you have a DC power supply, see Installing a DC Power Supply on page 75.	
3.	For the VSP 8400 Series, install an Ethernet Switch Module.	See Installing an Ethernet Switch Module on page 25.	
4.	Check the LEDs to verify the installation.	For a description of the LEDs, see LED state definitions on page 81.	

Installation fundamentals

VSP 8200 Series

The VSP 8200 Series consists of:

- eighty 10GBASE-SFP/SFP+ ports
- four 40GBASE-QSFP+ ports
- one 10/100/1000BASE-T Out-Of-Band Management Port
- one RJ-45 Console Port
- one USB 2.0 port
- Base Software License
- one field-replaceable 800 watt power supply (either AC or DC)
- four field-replaceable 12 volt fan modules

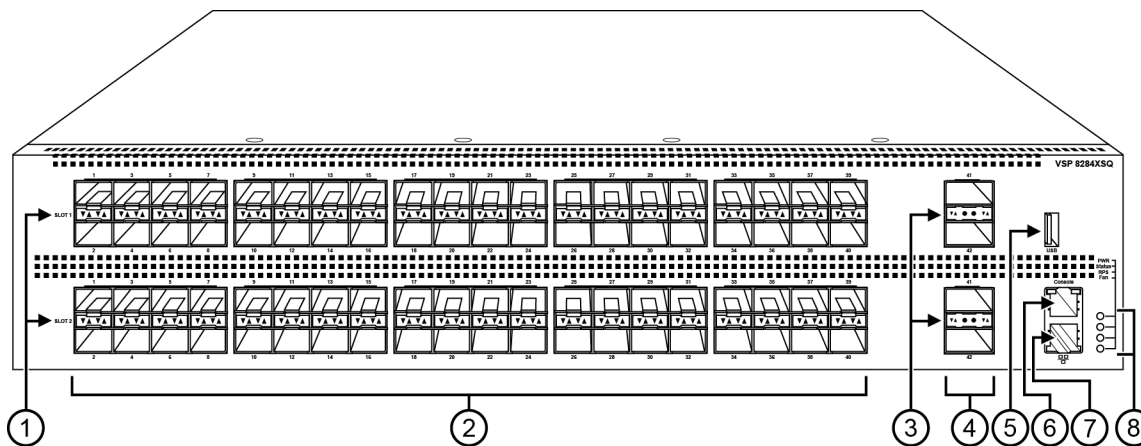


Figure 1: VSP 8284XSQ – Front view

1. SFP+ port LEDs are in between the ports on each slot. The up arrows refer to the port above and the down arrows refer to the port below. For a description of what the LEDs mean, see [SFP, SFP+, QSFP+, and QSFP28 port LED state indicators](#) on page 83.
2. Eighty SFP+ ports that support 1G SFPs and 10G SFP+s.
 - 40 ports in Slot 1 on top
 - 40 ports in Slot 2 on the bottom
3. QSFP+ port LEDs are in between the ports on each slot. The up arrows refer to the port above and the down arrows refer to the port below. For a description of what the LEDs mean, see [SFP, SFP+, QSFP+, and QSFP28 port LED state indicators](#) on page 83.
4. Four QSFP+ ports: two in Slot 1 and two in Slot 2.
5. USB port
6. Console port
7. Management port — The LEDs are on the bottom of the port. For more information, see [Management port LEDs](#).
8. LEDs for system power (PWR), switch status (Status), redundant power supply (RPS), and fan modules (Fan). For more information, see [Switch LEDs](#).

The following figure shows the rear of the chassis with four fan modules and one power supply installed. The fan modules are numbered 1–4 from left to right, and the power supplies are numbered PSU 1 on top and PSU 2 on the bottom.

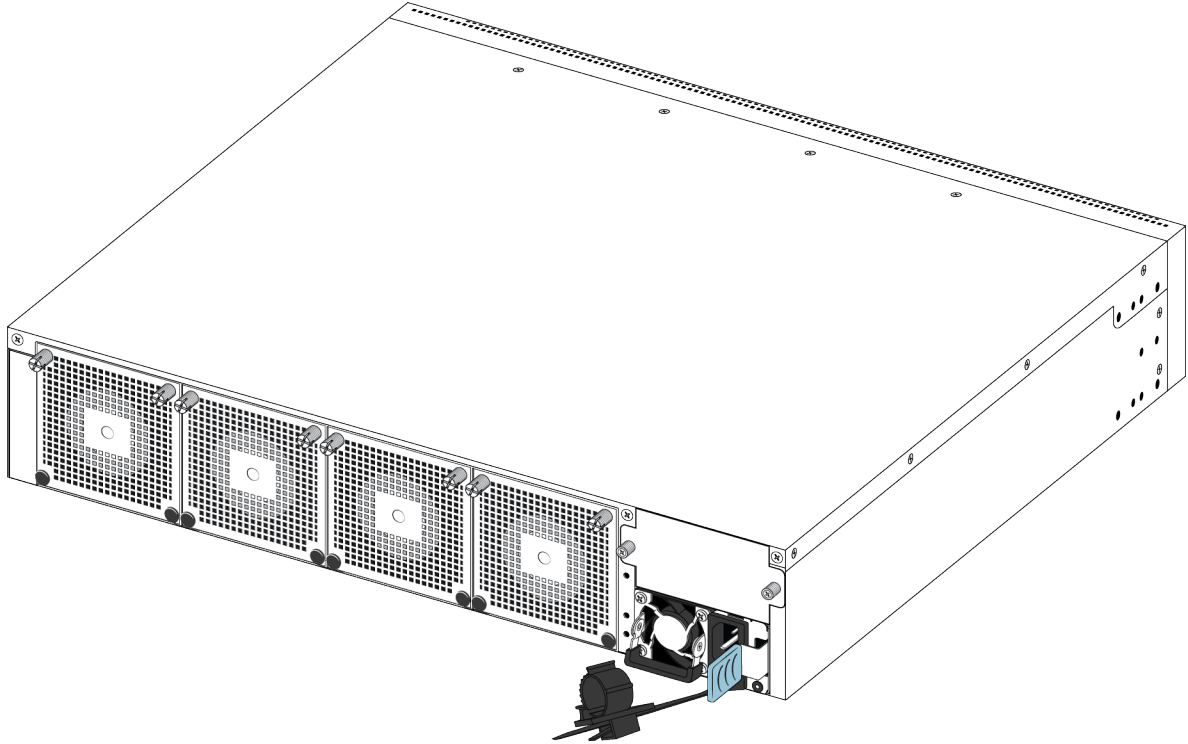


Figure 2: VSP 8284XSQ — Rear view

VSP 8400 Series

The VSP 8400 Series consists of:

- four slots to install ESMs. For more information, see [Ethernet Switch Module \(ESM\)](#).
- one 10/100/1000BASE-T Out-of-Band Management port
- one RJ45 console port
- one USB 2.0 port
- one field replaceable 800 watt power supply (AC or DC)
- four field replaceable 12 volt fan modules
- Base Software License

The following figure shows the front view of the VSP 8404.

Note



- The front view is common for both VSP 8404 and VSP 8404C models.
- When looking at the front of the switch, slot numbering begins at the top row and increases from left to right. Slot 1 is the top-left slot; slot 2 is the top-right slot. Slot 3 is the bottom-left slot; slot 4 is the bottom-right slot.

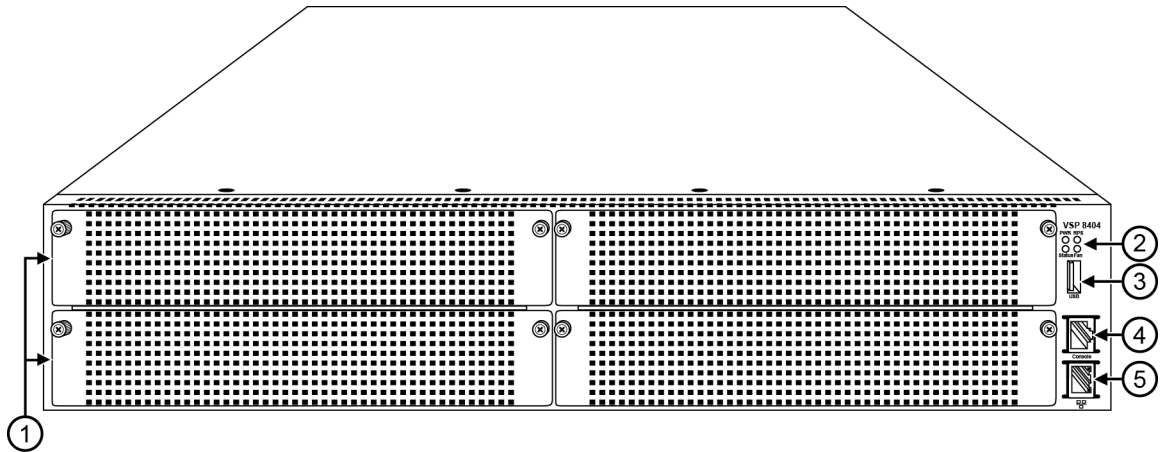


Figure 3: VSP 8404 Front view

- 1 Displays the four slots to install ESMs. For more information on the supported ESMs and their part numbers, see [Table 5](#) on page 12.
- 2 LEDs for system power (PWR), switch status (Status), redundant power supply (RPS), and fan modules (Fan).
- 3 USB port
- 4 Console port
- 5 OOB management port

Ethernet Switch Module

An Ethernet Switch Module (ESM) is a field replaceable expansion module that provides physical interfaces on the VSP 8400 Series. The VSP 8400 Series provides four expansion slots.

The VSP 8400 Series supports the following ESMs.

8424XS

- 8424XS – EC8404001-E6 – provides 24 1/10G SFP+ ports.
- 8424XS (GSA version) – EC8404001-E6GS – provides 24 1/10G SFP+ ports.

Dimension	4.4cm - 1RU (H), 20.32cm (W), 29.21cm (D)
Weight	3.80 lbs = 1.72 kg
Power and thermal	93.32W (max) = 318.41 BTU/hr

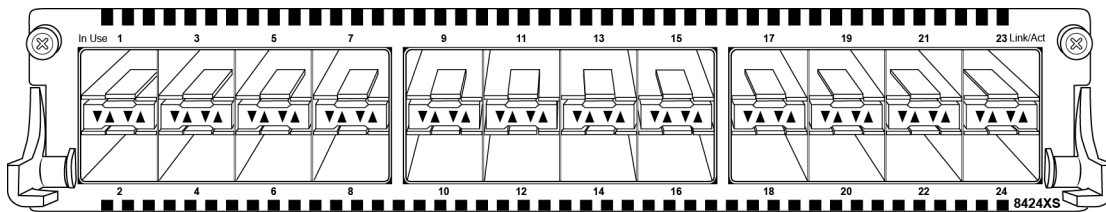


Figure 4: 8424XS

8424XT

- 8424XT – EC8404002-E6 – provides 24 100MB/1G/10G Copper ports.
- 8424XT (GSA version) – EC8404002-E6GS – 24 port 100MB/1G/10G Copper ports.

Dimension	4.4cm - 1RU (H), 20.32cm (W), 29.21cm (D)
Weight	4.05 lbs = 1.84 kg
Power and thermal	118.69W (max) = 404.97 BTU/hr

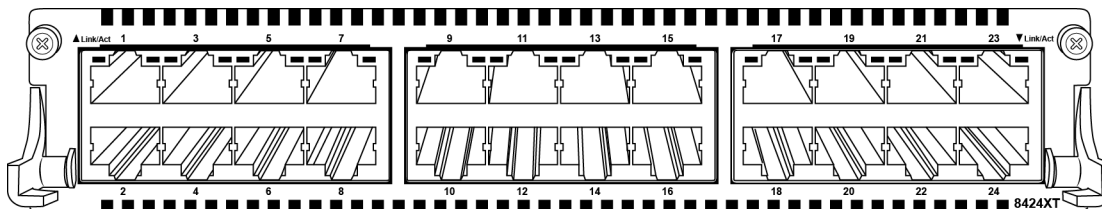


Figure 5: 8424XT

8408QQ

- 8408QQ – EC8404003-E6 – provides 8 40G QSFP+ ports.
- 8408QQ (GSA version) – EC8404003-E6GS – 8 40G QSFP+ ports.

Dimension	4.4cm - 1RU (H), 20.32cm (W), 29.21cm (D)
Weight	3.55 lbs = 1.61 kg
Power and thermal	88.64W (max) = 302.44 BTU/hr

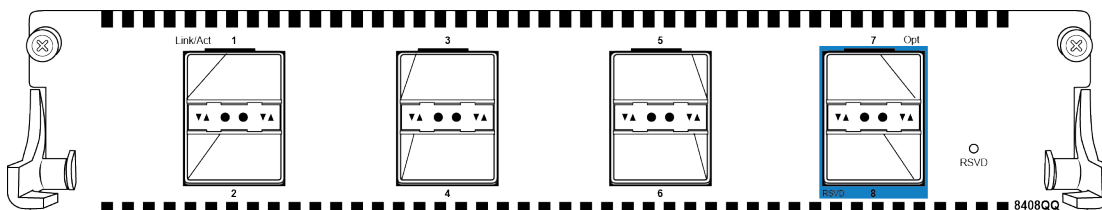


Figure 6: 8408QQ



Important

As shown in the above figure, ports 7 and 8 are reserved for future use.

8418XSQ

- 8418XSQ – EC8404005-E6 – 16 1/10G SFP+ and 2 40G QSFP+ ports.
- 8418XSQ (GSA version) – EC8404005-E6GS – 16 1/10G SFP+ and 2 40G QSFP+ ports.

Dimension	4.4cm - 1RU (H), 20.32cm (W), 29.21cm (D)
Weight	3.7 lbs = 1.68 kg
Power and thermal	86.89W (max) = 296.47 BTU/hr

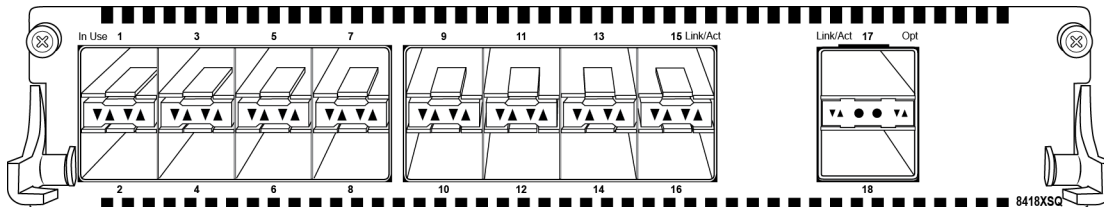


Figure 7: 8418XSQ

8418XTQ

- 8418XTQ – EC8404006-E6 - 16 1/10G Copper and 2 40G-QSFP+ ports.
- 8418XTQ (GSA version) – EC8404006-E6GS - 16 1/10G Copper and 2 40G-QSFP+ ports.

Dimension	4.4cm - 1RU (H), 20.32cm (W), 29.21cm (D)
Weight	4.0 lbs = 1.81 kg
Power and thermal	136W (max) = 464 BTU/hr

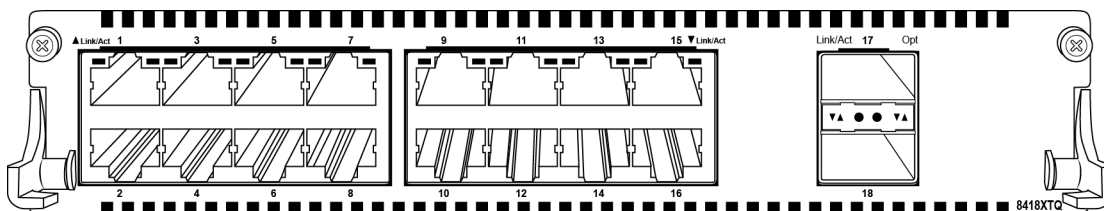


Figure 8: 8418XTQ

8424GS

- 8424GS – EC8404007-E6 - 24 100/1000M-SFP ports.
- 8424GS (GSA version) – EC8404007-E6GS - 24 100/1000M-SFP ports.

Dimension	4.4cm - 1RU (H), 20.32cm (W), 29.21cm (D)
Weight	2.75 lbs = 1.25 kg
Power and thermal	49.68W (max) = 126.71 BTU/hr

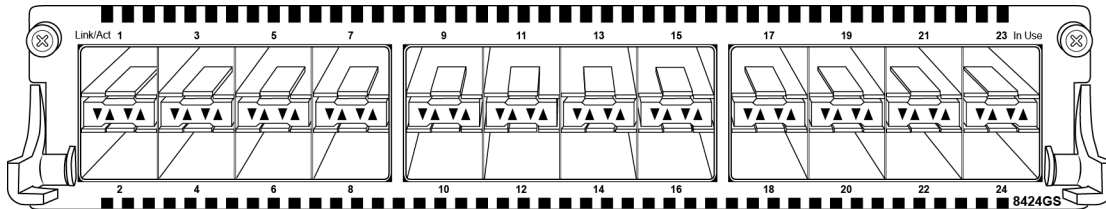


Figure 9: 8424GS

8424GT

- 8424GT – EC8404008-E6 – 24 10/100/1000M Copper ports.
- 8424GT (GSA version) – EC8404008-E6GS – 24-port 10/100/1000M Copper ports.

Dimension	4.4cm - 1RU (H), 20.32cm (W), 29.21cm (D)
Weight	2.75 lbs = 1.25 kg
Power and thermal	12.62W (max) = 47.90 BTU/hr

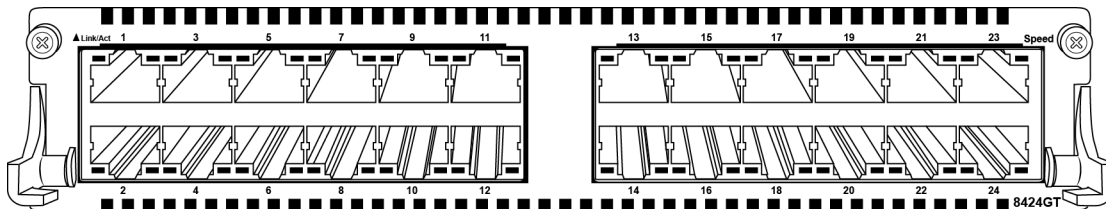


Figure 10: 8424GT

8402CQ

- 8402CQ – EC8404009-E6 2 100G QSFP28 ports
- 8402CQ (GSA version) – EC8404009-E6GS 2 100G QSFP28 ports



Important

The 8402CQ ESM can operate only on the VSP 8404C platform.

Dimension	4.4cm - 1RU (H), 20.32cm (W), 29.21cm (D)
Weight	2.75 lbs = 1.25 kg
Power and thermal	22.44W (max) = 76.57 BTU/hr



Figure 11: 8402CQ



Installing an Ethernet Switch Module

Install an ESM to replace an existing module or to add new capability.

The switch has four bays and you can choose any one of them to install a module. The switch detects where the modules are installed so the order is not important.

You can also install a new module or hot swap an existing module while the switch is operational.



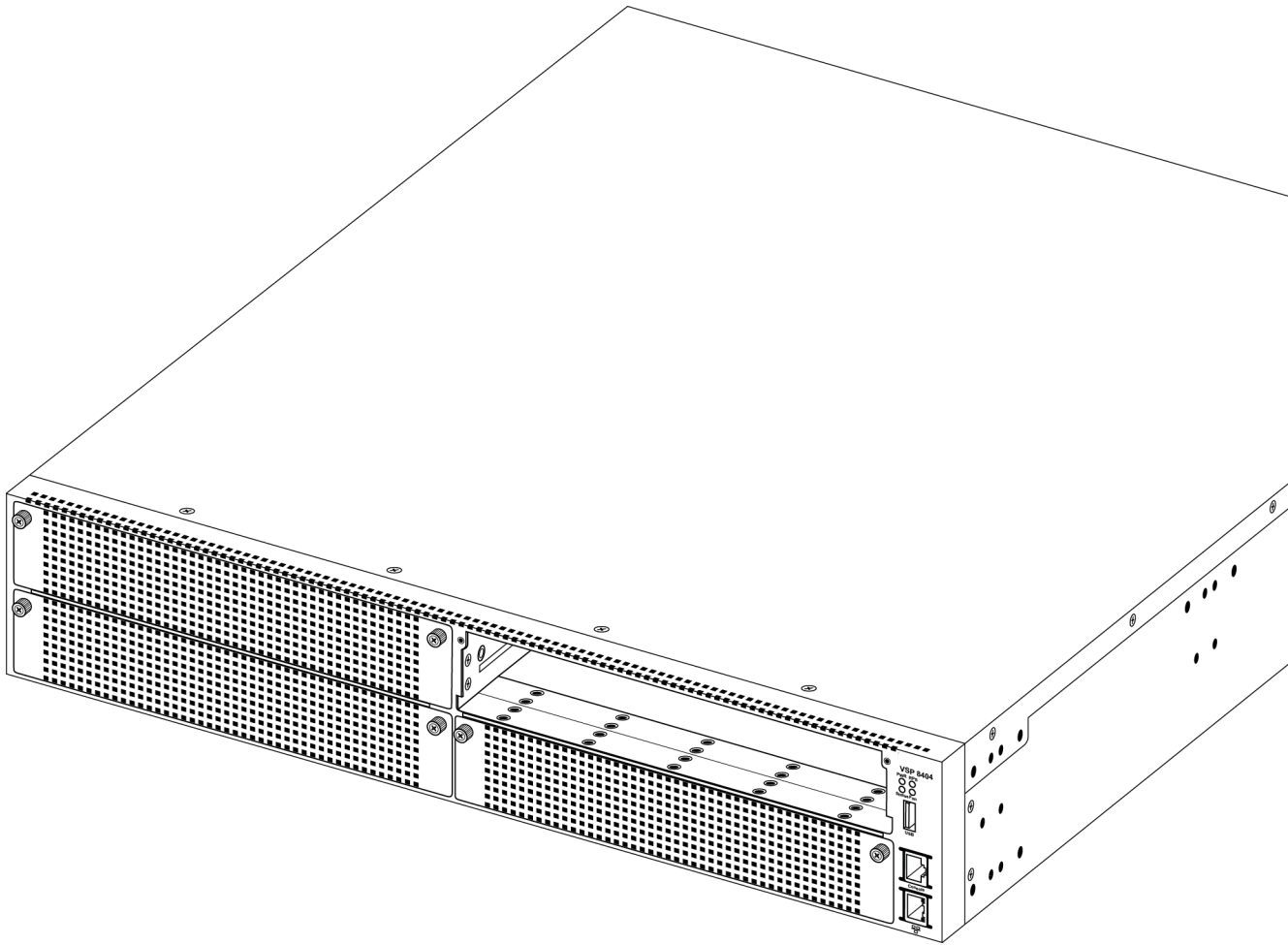
Note

When looking at the front of the switch, slot numbering begins at the top row and increases from left to right. Slot 1 is the top-left slot; slot 2 is the top-right slot. Slot 3 is the bottom-left slot; slot 4 is the bottom-right slot.

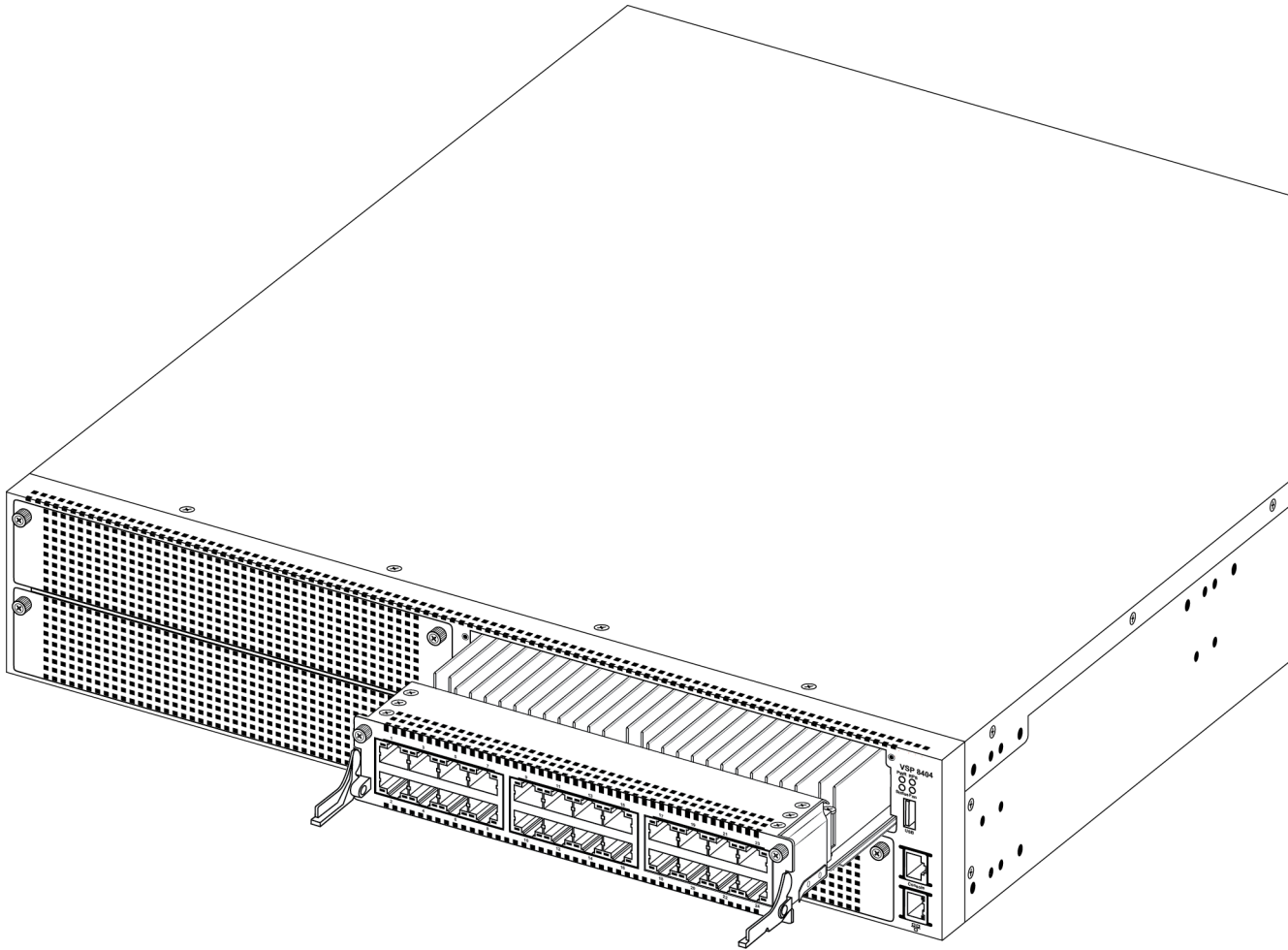
To prevent damage, handle the ESMs carefully by using the following guidelines:

- To prevent damage from electrostatic discharge, always wear an antistatic wrist strap connected to an ESD jack.
- Always place the modules on appropriate antistatic material.
- Support the module from underneath with two hands. Do not touch components or connector pins with your hand, or damage can result.
- Visually inspect the connectors for damage before you insert the module. If you insert a module with damaged connectors you will damage the switch.
- Do not stack modules one on top of the other when you move them.
- Do not leave bays open. Fill all bays with modules or module bay covers to maintain safety compliance, proper cooling, and EMI containment.
- Do not over tighten screws. Tighten until snug. Do not use a power tool to tighten screws.

- 1 Remove the two screws that secure the module bay cover to the chassis. (Save the module bay cover for possible future use.)



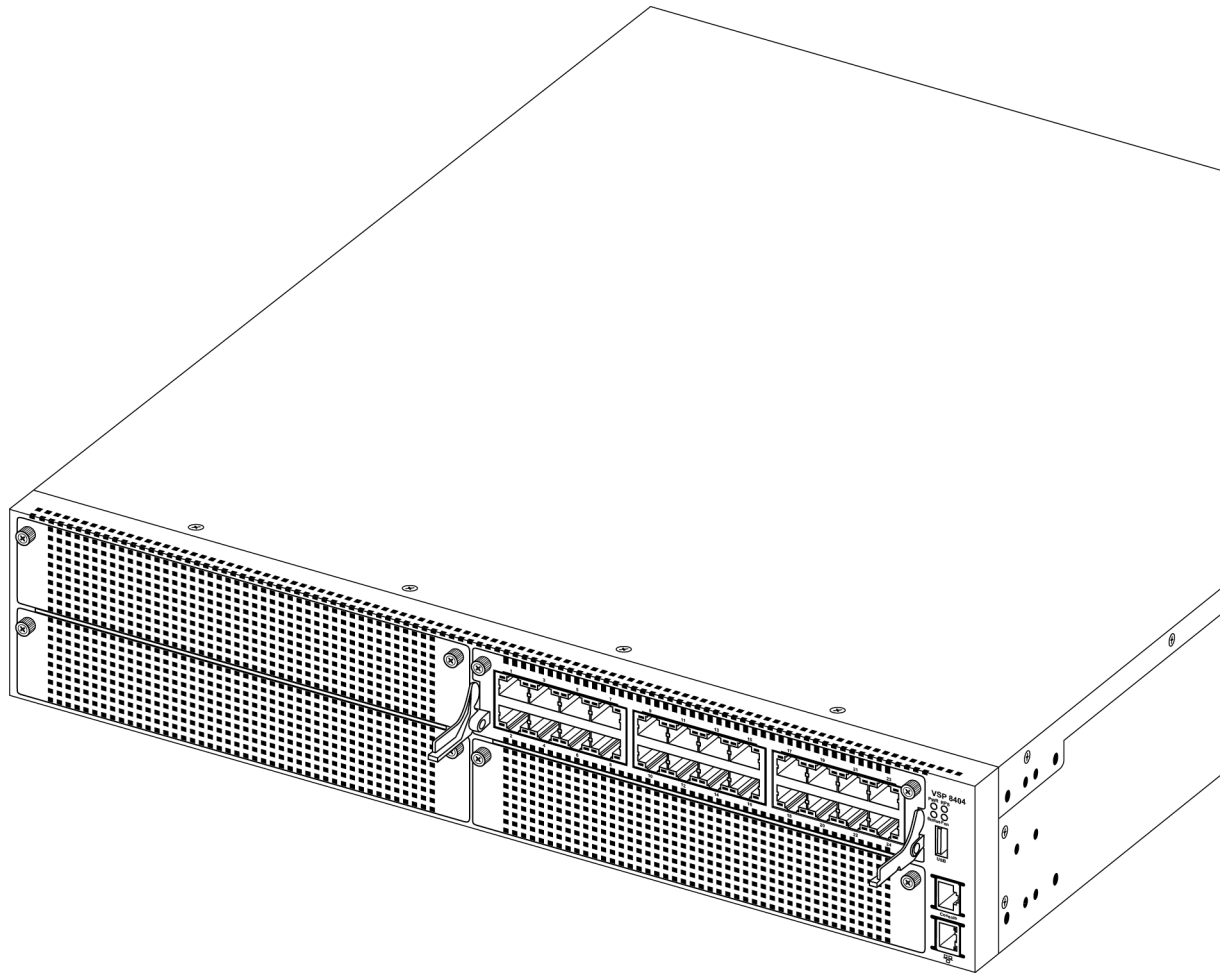
- 2 Slide the module into the bay.



- 3 Apply gentle pressure anywhere on the faceplate to fully insert the module, and then screw the module in to ensure a good connection and to secure it to the chassis.

Note

The levers are designed to stay in the position shown when the module is inserted into the chassis. The lever the module.



If you have to remove a module, loosen the two screws that secure the module to the chassis and rotate the extract levers up to eject the module from the chassis. Remove the module, and then either install another module or replace the module bay cover.

Important

You must have either a module or a module bay cover in each bay to ensure proper ventilation. Leaving a module bay unpopulated or uncovered impairs the ability of the fans to cool the chassis.

Hot swap of VSP 8400 Series Ethernet Switch Module

Hot swap is the ability to add, remove, or replace system components without shutting down the system and without interrupting the operation of the system. The VSP 8400 Series supports the hot swap of ESMs, power supply units, and fan modules.

The following table explains the methods of hot swapping in VSP 8400 Series.

Table 8: Methods of hot swapping in VSP 8400 Series

Hardware	Description
Power supply	You can hot swap power supplies while the switch is operational. One power supply is required for continuous switch operation.
8402CQ ESM	Hot insertion or removal of the 8402CQ is not supported.
Important: The 8402CQ ESM can only be installed on the VSP 8404C platform.	8402CQ can only be hot swapped with another 8402CQ using Performing a controlled hot swap on page 30.
	The 8402CQ must not be hot removed or pulled from the slot.
	Important: The slot becomes inoperable until the next reboot.
	Follow Performing a controlled hot swap on page 30, to replace or remove the 8402CQ .
	For 8402CQ to operate, it must be inserted prior to the boot time. Insertion of the 8402CQ into an empty slot while the switch is operational, results in a log error message and the slot remains powered off until the 8402CQ is removed, and a different ESM type is inserted.
All other ESMs	Any ESM can be hot swapped or replaced with the same ESM type. The rest of the configuration continues to work as original until the ESM comes online, after which the configuration for that ESM is applied.
	Any ESM except the 8424XT , 8418XTQ , 8424GS , and 8424GT can be hot swapped or replaced with 8418XSQ , 8424XS , or 8408QQ . The rest of the configuration continues to work as original until the replacement ESM comes online. When the replacement ESM is online the previous configuration for that slot is removed from the running configuration. The new ESM type can now be configured.
	The 8424XT , 8418XTQ , 8424GS , and 8424GT ESMs can only be hot swapped or replaced with another ESM of the same type. The rest of the configuration continues to work as original until the ESM comes online, after which the configuration for that ESM is applied.
	Upon pulling out an 8424XT , 8418XTQ , 8424GS or 8424GT ESM, and inserting another type of ESM, the new module is powered off without any initialization and the system must be rebooted to utilize that slot. An alarm or message is logged to indicate that slot is powered off and requires the insertion of the previous card type to restore the related configuration.
	Upon pulling out an 8418XSQ , 8424XS , or 8408QQ and inserting an 8424XT , 8418XTQ , 8424GS , or 8424GT , the newly inserted ESM is powered off without any initialization and the system must be rebooted to utilize that slot. An alarm or message is logged to indicate that slot is powered off and requires the insertion of the previous card type to restore the related configuration.

Performing a controlled hot swap

Use the following procedure to replace or remove ESMs from the slot.



Important

Controlled hot swap is mandatory for **8402CQ** ESM.

- 1 Enter Global Configuration mode:

```
enable
```

```
configure terminal
```

- 2 Shut down the slot:

```
no sys power slot {slot[-slot][, ...]}
```

Or

```
slot shutdown {slot[-slot][, ...]}
```



Note

`slot reset` command is not equivalent to controlled hot swap, and it is not sufficient for 8402CQ module reinsertion.

- 3 Wait for ten seconds.
 - 4 Remove the ESM from the slot.
 - 5 Insert the new ESM in the slot.
 - 6 Power on the slot:
- ```
sys power slot {slot[-slot][, ...]}
```

Or

```
no slot shutdown {slot[-slot][, ...]}
```

## 40G channelization

Channelization allows you to configure each 40Gbps QSFP+ ports to operate as four separate 10Gbps ports. You can use QSFP+ to four SFP+ breakout cables or QSFP+ transceivers with fiber breakout cables to connect the 10 Gigabit Ethernet ports to other servers, storage, and switches. By default, the ports are not channelized, which means that the 40Gbps QSFP+ ports operate as 40Gbps ports. You can enable or disable channelization on a port.

For breakout cable (BOC) details, see [Extreme Networks Pluggable Transceivers Installation Guide](#).

## Electrostatic discharge

This section provides information and procedures to prevent electrostatic discharge during installation.

## Preventing electrostatic discharge damage

Electrostatic discharge (ESD) is a discharge of stored static electricity that can damage equipment and impair electrical circuitry. Electrostatic voltages can result from friction including, pulling cabling through conduits, walking across carpeted areas, and building static charge in clothing. When you improperly handle electronic components, ESD damage occurs and can result in complete or intermittent failures. While networking equipment is commonly designed and tested to withstand common mode ESD events, voltage can sometimes discharge to some connector pins, which can potentially damage the networking equipment.

### Caution

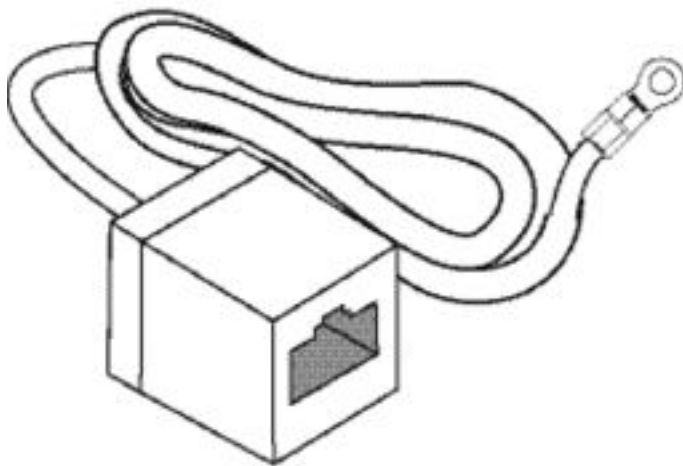
To protect the switch against ESD damage, take the following measures before you connect data cables to the device:



- Always use antistatic wrist straps. Make sure you adjust the strap to provide good skin contact.
- Ensure that you properly ground work surfaces and equipment racks for protection against electrostatic discharge. You must connect the common point to the building ground wire. In a properly wired building, the nearest reliable ground is typically at the electrical outlet.
- Avoid contact between equipment and clothing. The wrist or ankle strap protects only the equipment from ESD voltages on the body; ESD voltages on clothing can still cause damage.
- Avoid touching any connector pins.
- Do not remove the wrist or ankle strap until the installation is complete.

## Preventing electrostatic damage in new cable installations

With new cable installations, Extreme Networks recommends that you use an ESD discharge cable to reduce the potential for damage from static, that can build up in cables. The following figure illustrates an ESD cable.



**Figure 12: Job aid**

To install the ESD discharge cable, perform this procedure.

- 1 Connect the ground lug on the ESD discharge cable to a safe and suitable earth ground.
- 2 Connect all RJ-45 cable connectors to the female RJ-45 connector of the ESD discharge cable for at least 5 seconds, and then connect each RJ-45 cable connector to the switch.
- 3 Leave cables connected to the networking equipment. After you connect cables to networking equipment, the cables do not build up charge.

## Technical specifications

The following table provides the technical specifications for the individual switches in this series. Ensure that the area where you install the switch and where it operates meets these requirements.



### Warning

To avoid bodily injury from hazardous electrical shock and current, never remove the top of the device. No user-serviceable components are inside.

**Table 9: Physical specifications**

| Specifications                       | VSP 8200 Series                               | VSP 8400 Series                                                                                   |
|--------------------------------------|-----------------------------------------------|---------------------------------------------------------------------------------------------------|
| Height                               | 3.5 in. (88.9mm) – 2U                         | 3.5 in. (88.9mm) – 2U                                                                             |
| Width                                | 17.5 in. (444.5 mm) - 19" rack mountable      | 17.5 in. (444.5 mm) – 19" rack mount compatible                                                   |
| Depth                                | 19.68 in. (500 mm)                            | 26.5 in. (673 mm)                                                                                 |
| Weight                               | 32.1 lb (14.56 kg) VSP 8284XSQ (EC8200x01-E6) | 33.35 lb (15.13 kg) - Weight includes fan modules only (no power supplies or ESMs) (EC8400x01-E6) |
| Weight of spare AC power supply unit | 1.9 lb (0.862 kg) (EC8005x01-E6)              | 1.9 lb (0.862 kg) (EC8005x01-E6)                                                                  |
| Weight of spare DC power supply unit | 1.76 lb (0.8 kg) (EC8005001-E6)               | 1.76 lb (0.8 kg) (EC8005001-E6)                                                                   |



**Table 10: Electrical specifications**

| Specifications    | VSP 8200 Series                                                                                                      | VSP 8400 Series                                                                                                                                                                                                                                                                                                                                                                                                                               |
|-------------------|----------------------------------------------------------------------------------------------------------------------|-----------------------------------------------------------------------------------------------------------------------------------------------------------------------------------------------------------------------------------------------------------------------------------------------------------------------------------------------------------------------------------------------------------------------------------------------|
| Power consumption | 565.34 W with no transceivers, 765.34 W with transceivers                                                            | 200 W with no ESMs, 800 W (max) with ESMs                                                                                                                                                                                                                                                                                                                                                                                                     |
| Thermal rating    | 1929.02 BTU/hr with no transceivers, 2611.448 BTU/hr with transceivers                                               | 682.4 BTU/hr with no ESMs, 2729.7 BTU/hr with ESMs                                                                                                                                                                                                                                                                                                                                                                                            |
| MTBF rating       | Chassis = 137,000 hours (15.6 years)<br>800W AC Power Supply = 361,361 hours<br>800W DC Power Supply = 536,691 hours | Chassis = 241,723 hours<br>ESMs:<br><ul style="list-style-type: none"> <li>• 8424GS = 676,000 hours</li> <li>• 8424GT = 857,000 hours</li> <li>• 8424XS = 691,864 hours</li> <li>• 8424XT = 582,142 hours</li> <li>• 8408QQ = 622,514 hours</li> <li>• 8418XSQ = 742,318 hours</li> <li>• 8418XTQ = 575,500 hours</li> <li>• 8402CQ = 1,400,921 hours</li> </ul> 800W AC Power Supply = 361,361 hours<br>800W DC Power Supply = 536,691 hours |

**Table 11: CPU and Memory**

| CPU/Memory                             |
|----------------------------------------|
| Dual Core, 1.33GHz Freescale P2020 CPU |
| 2 GB DDR3 ECC memory                   |
| 512 MB NOR Flash Memory                |
| 12 MB packet buffer per chip           |

**Table 12: Environmental specifications**

|                            |                                                 |
|----------------------------|-------------------------------------------------|
| Operating Temperature      | 0° C to 50° C (32° F to 122° F)                 |
| Storage Temperature        | -40° C to 85° C (-40° F to 185° F)              |
| Operating Humidity         | 0 to 95 percent noncondensing                   |
| Storage Humidity           | 0 to 95 percent noncondensing                   |
| Maximum Operating Altitude | 3,048m (10 000 feet) above sea level            |
| Storage Altitude           | 0 to 12,192m (0 to 40,000 feet) above sea level |

**Table 12: Environmental specifications (continued)**

|                                        |                                                                                                                                                                                                                                                                                                                                                                                                                                                                                                                                                                                          |
|----------------------------------------|------------------------------------------------------------------------------------------------------------------------------------------------------------------------------------------------------------------------------------------------------------------------------------------------------------------------------------------------------------------------------------------------------------------------------------------------------------------------------------------------------------------------------------------------------------------------------------------|
| Acoustic Noise                         | Less than or equal to 35 db at 21° C and less than or equal to 43 db at 50° C. The temperature is allowed to have $\pm 3.5^\circ$ C deviation around the threshold of 35C, (measurement methods based on ISO 7779).                                                                                                                                                                                                                                                                                                                                                                      |
| Miscellaneous Operating Considerations | <ul style="list-style-type: none"> <li>• No heat sources such as hot air vents or direct sunlight near the switch.</li> <li>• No sources of severe electromagnetic interference near the switch.</li> <li>• No excessive dust in the environment.</li> <li>• An adequate power source is within 6 feet (1.83 meters) of the switch. One 15-amp circuit is required for each power supply.</li> <li>• At least 2 inches (5.08 centimeters) of clearance on the front and back of the switch for ventilation.</li> <li>• Cables should be dressed to prevent blocking air flow.</li> </ul> |

## Package contents

The following describes the components that are provided with each switch. If any components are missing, contact Extreme Networks.

- 1 VSP 8000 Series switch
- 2 Rack-mounting hardware that includes:
  - Rack-mount brackets
  - Screws to attach brackets to the switch
  - Screws to secure the switch to the equipment rack
- 3 The VSP 8000 Series supports two field-replaceable power supplies. One power supply ships with the unit.
- 4 Four field-replaceable fan modules
- 5 Documentation

### Note



A 300mm-900mm slide rack mounting kit is available as an option.

Power cords must be ordered separately. Ensure you order the correct power cord for your region. For more information, see [Power cord types and order codes](#).

## Installing the VSP 8000 Series in an Equipment Rack

### Note



The instructions in this section apply to all switches in the VSP 8000 Series. The illustrations show the VSP 8200 Series as an example, but the instructions apply to any switch in the series.

There are different ways to install a VSP 8000 Series switch in an equipment rack. Refer to one of the following sections:

- Slide Rack Mount Kit-This is a separately ordered option that you can use to install your switch in equipment racks that range from 300 mm to 900 mm deep. For installation instructions, see [Using the optional slide rack mount kit](#).
- Brackets-The switch comes with brackets that you can install in one of two positions on the chassis:
  - Use the mid-chassis position for a two-post rack.
  - Use the front panel position of the chassis for a four-post rack.

---

**Caution**

It is highly recommended to mount the chassis on a tray designed for the specific rack and use the Extreme Networks supplied rack mount brackets to hold the chassis in place. The chassis is heavy and could cause damage to a rack if only the brackets are used, especially in a vibration prone area.

---

For installation instructions, see [Using the supplied bracket](#).

- Ensure that there is enough rack space to accommodate a 2 U switch (8.8 cm).
- The rack is bolted to the floor and braced if necessary.
- The rack is grounded to the same grounding electrode used by the power service in the area. The ground path must be permanent and must not exceed 1 Ohm of resistance from the rack to the grounding electrode.

---

**Caution**

When you mount the device in a rack, do not stack units directly on top of one another. You must secure each unit to the rack with the appropriate mounting brackets. Mounting brackets cannot support multiple units. For a translation of this statement, see [Translations of safety messages](#) on page 89.

---

## Using the optional slide rack mount kit

The Universal Slide Rack Mount Kit is adjustable so that you can install your switch in equipment racks of different sizes. Use the following procedures to install your switch in equipment racks with a depth from 300mm to 900mm.

This kit is a separately ordered item (Part # EC8011002).

For instructions see:

- [Inventory of slide components](#)
- [Installing slides in a 300mm-600mm equipment rack](#)
- [Installing slides in a 600mm-900mm equipment rack](#)
- [Important notice about rack safety](#)
- [Removing the switch from an equipment rack](#)

**Warning**

If you pull the switch all the way out on the slide rails, there is a danger of the rack tipping over. For more information and guidelines, see [Important notice about rack safety](#).

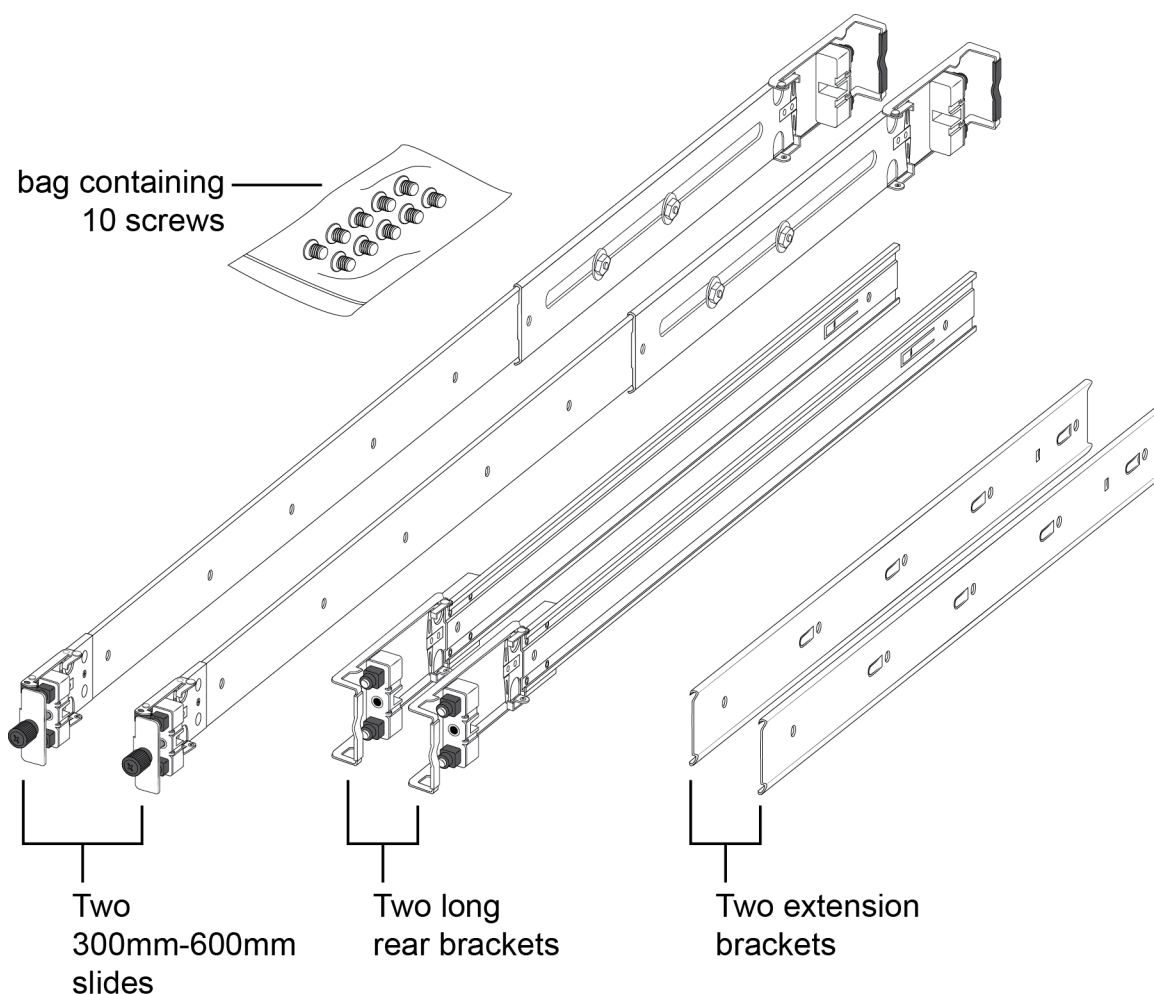
---

*Inventory of slide components*

This section describes the slide components and their features.

The shipping carton contains the following components:

- Two 300mm-600mm slides (default configuration)
- Two extension brackets for the 600mm-900mm configuration
- Two long rear brackets for the 600mm-900mm configuration
- Bag of screws

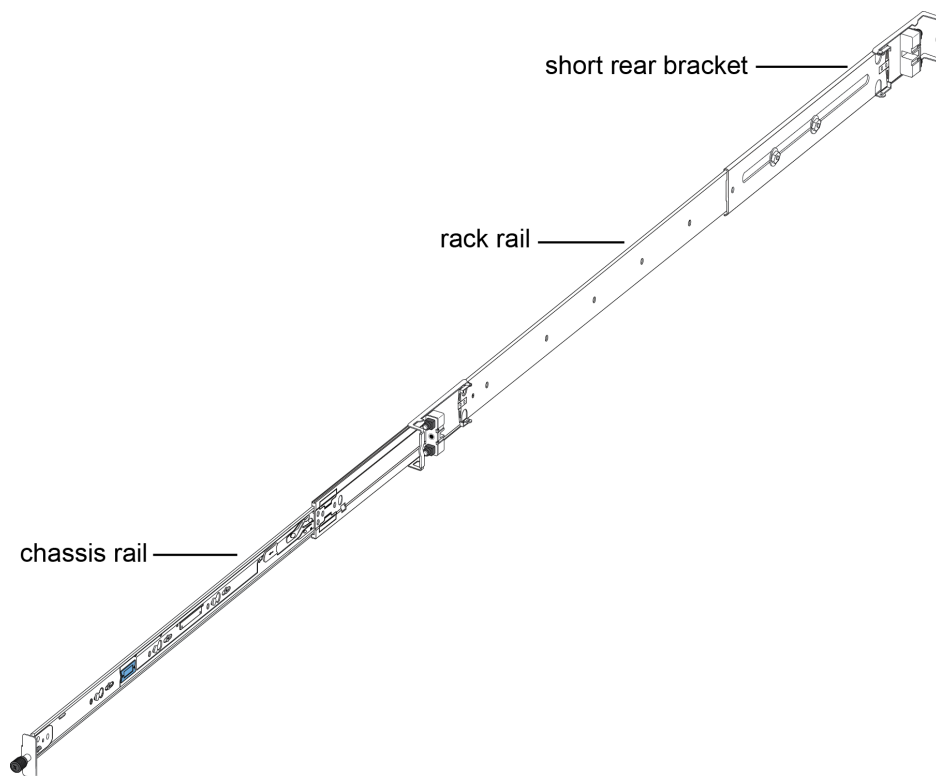


**Figure 13: Shipping components**

### Rails

The following figure shows a slide rail in the default configuration for a 300mm-600mm equipment rack. This configuration comes with the short rear bracket installed. The slide rail actually consists of two separate rails that slide into each other:

- Rack rail—This rail is the main component that connects to the equipment rack.
- Chassis rail—This rail is embedded in the rack rail. Later, the installation instructions explain how to detach these two rails and install the chassis rail onto your switch.

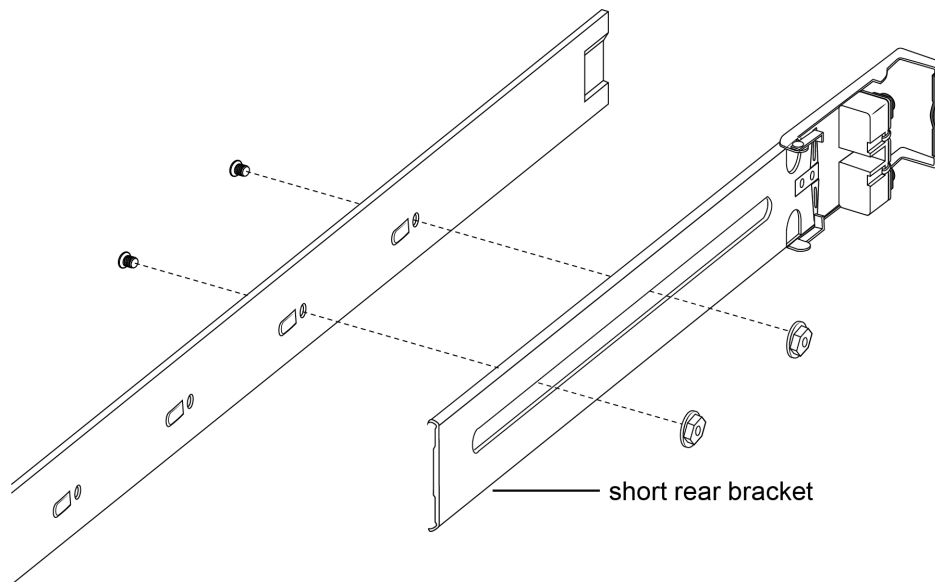


**Figure 14: Rails**

#### Brackets

There are three different brackets:

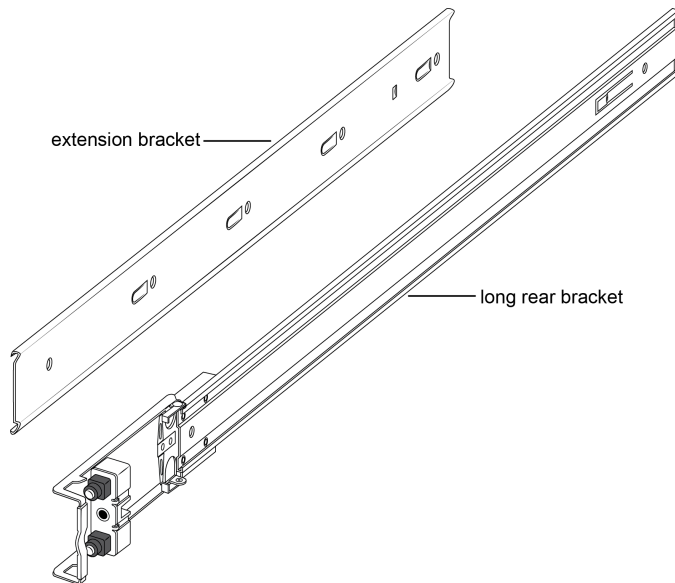
- Short rear bracket—The slide rail kit comes with this bracket installed for the 300mm-600mm default configuration.



**Figure 15: Short rear bracket**

- Extension bracket—This bracket connects to the rack rail to lengthen it for a 600mm-900mm configuration.
- Long rear bracket—This bracket replaces the short rear bracket to modify the slide rail for a 600mm-900mm configuration.

The following figure shows the extension bracket and the long rear bracket. Both are used for a 600mm–900mm configuration.

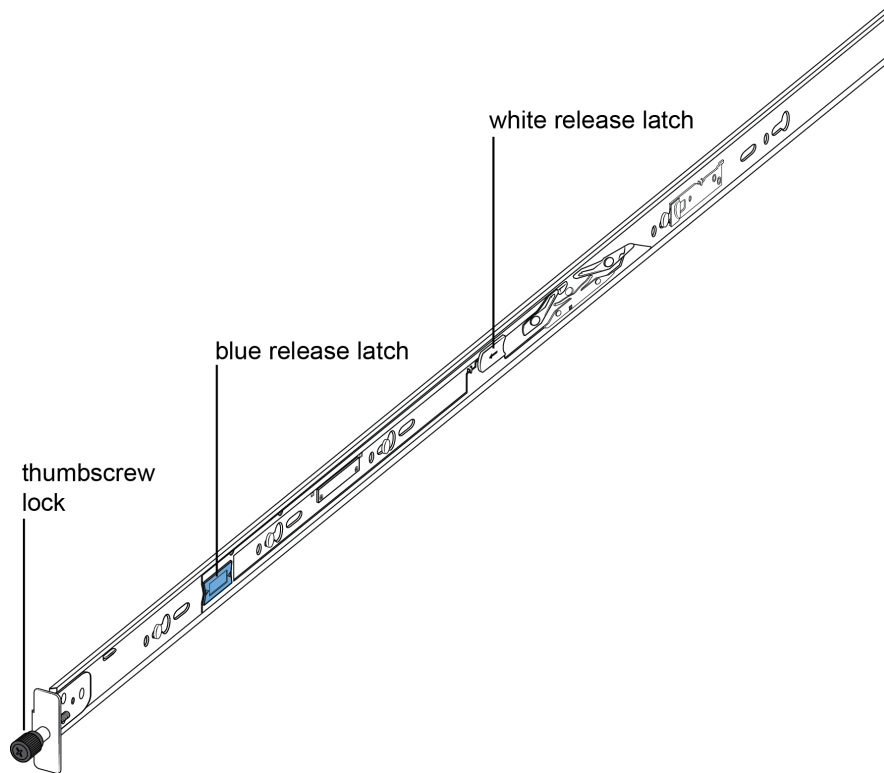


**Figure 16: Extension and long rear brackets**

### **Locks and latches**

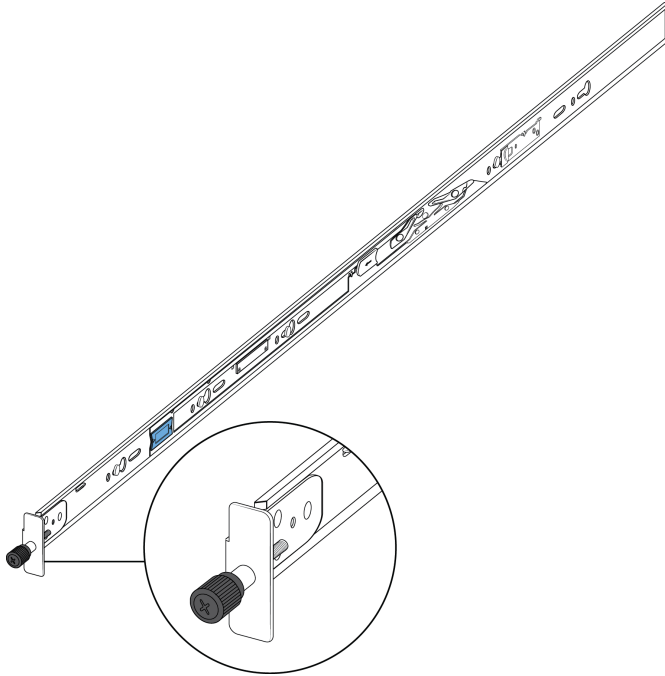
This section describes the locks and latches on the rails and where they are located.

The thumbscrew lock and the two release latches are on the chassis rail as shown in the following figure



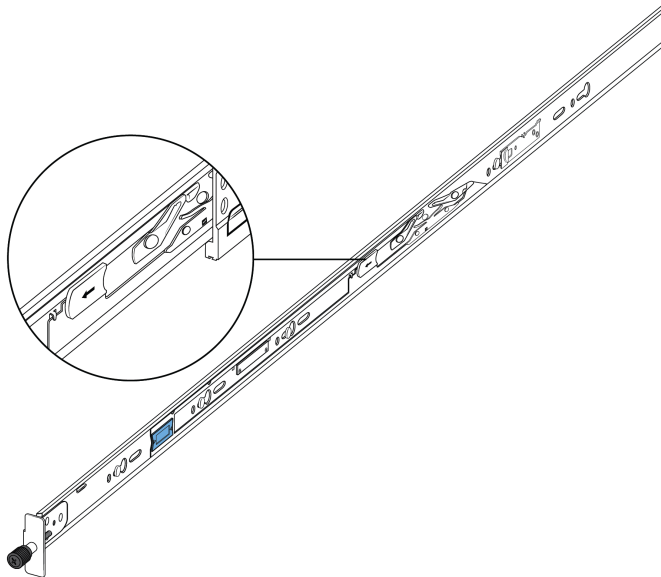
**Figure 17: Thumbscrew lock and release latches**

- Thumbscrew lock—This feature is on the front end of the chassis rails, and is used to lock the switch in the home position of the equipment rack.



**Figure 18: Thumbscrew lock**

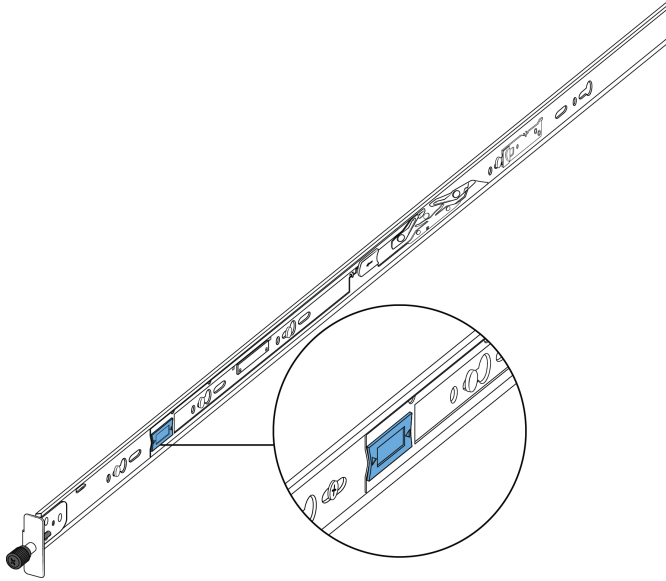
- White release latch—This latch is the white, plastic tab on the chassis rails.
  - When you first install the slide rails, use these latches to disconnect the chassis rail from the rack rail so you can install the chassis rail on the switch.
  - After you install the switch in a rack, you can use the white release latches to remove a switch from an equipment rack, if necessary.



**Figure 19: White release latch**

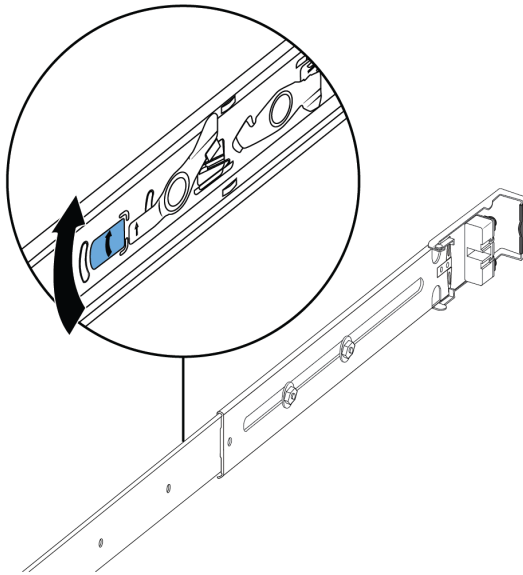
- Blue release latch—This latch is a blue, plastic tab that is also on the chassis rail. Use these latches to slide the switch into the equipment rack.





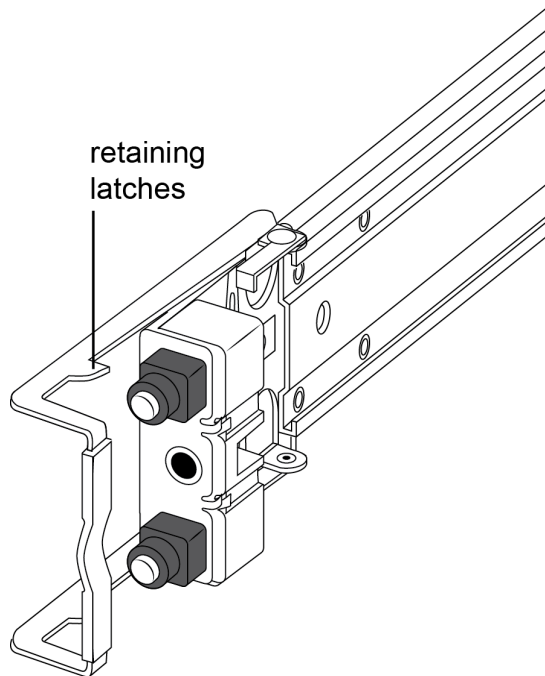
**Figure 20: Blue release latch**

- Blue locking mechanism—This locking mechanism is on the rack rails. They have a blue label with an arrow.



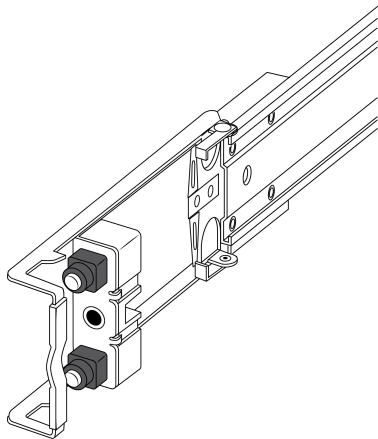
**Figure 21: Blue locking mechanism**

- When you first install the slide rails and you fully extended the rail, you can lift the locking mechanism to release the rail so it can slide back into the main part of the unit.
- When you install the switch in a rack and then pull the switch out, this mechanism automatically locks the slide rail in a fully extended position.
- Retaining latch—These latches are on the front and back of the slide rails. Use the hooks on these latches to wrap around the frame of the equipment rack and lock the rail into place.

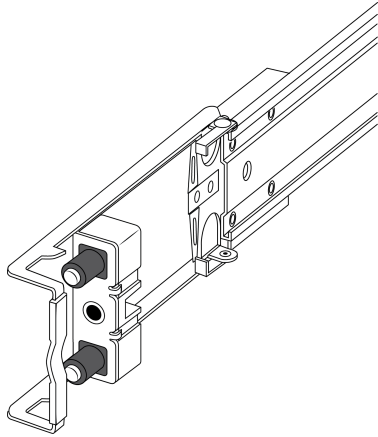


**Figure 22: Retaining latches**

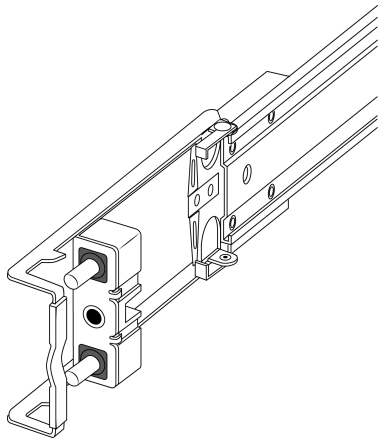
- Pin block—The pin block supports equipment racks with different shaped holes.
- For racks with square holes, the pin block fits right into the holes in the rack.



- For racks with large round holes, the pin block retracts halfway when you insert the rail into the rack.



- For racks with small round holes, the pin block retracts all the way when you insert the rail into the rack.



#### *Installing slides in a 300mm-600mm equipment rack*

Use the following procedure to install your switch in an equipment rack with a depth between 300mm and 600mm.

#### **Important**



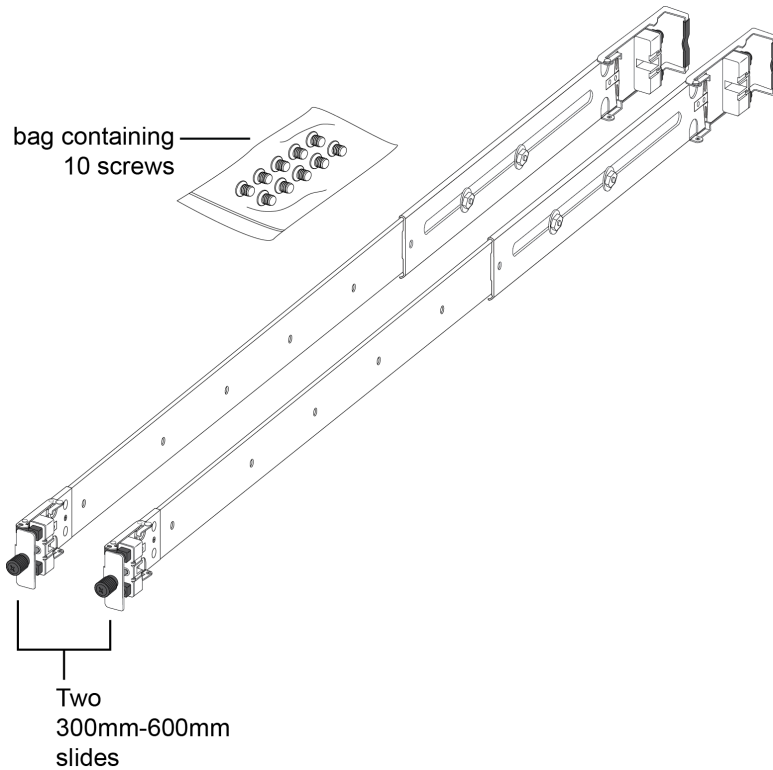
The Slide Rack Mount Kit is fairly complex due to its versatile design. To make your installation easier, read the [Inventory of slide components](#) section to familiarize yourself with the slide components and features.

- 1 Disconnect the power cord from the switch.

- 2 Open the shipping carton and remove the bag of screws and the two slides used in 300mm-600mm racks.

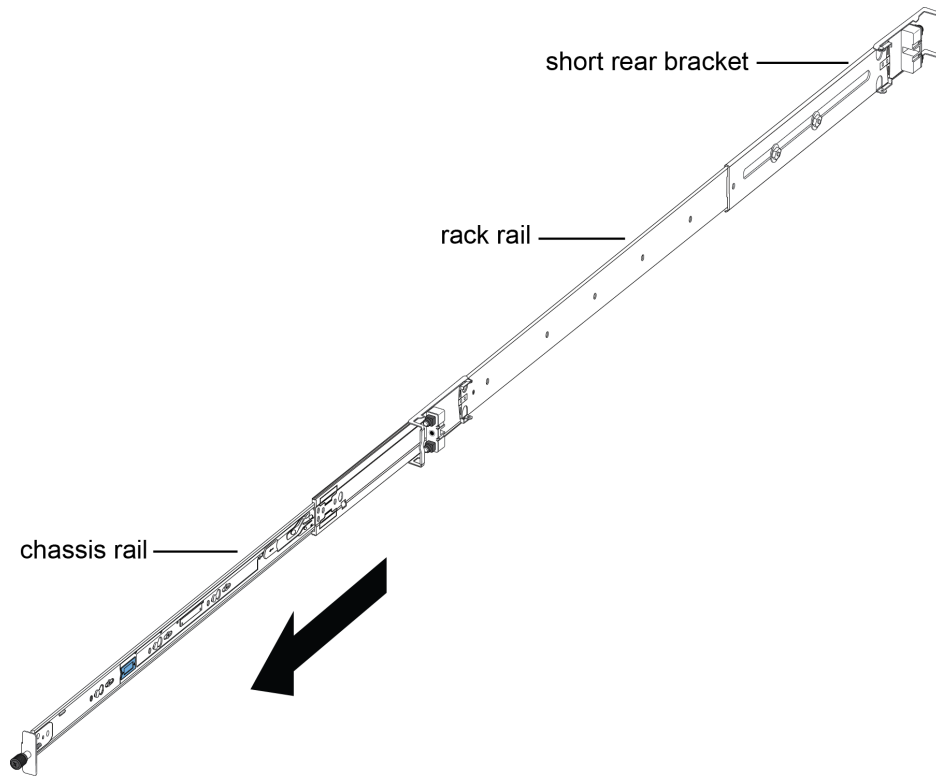
**Note**

The 300mm-600mm slides are the default configuration. The remaining parts in the carton (including the bag of screws) are for installing the chassis in a 600mm-900mm. Save them for potential future use.

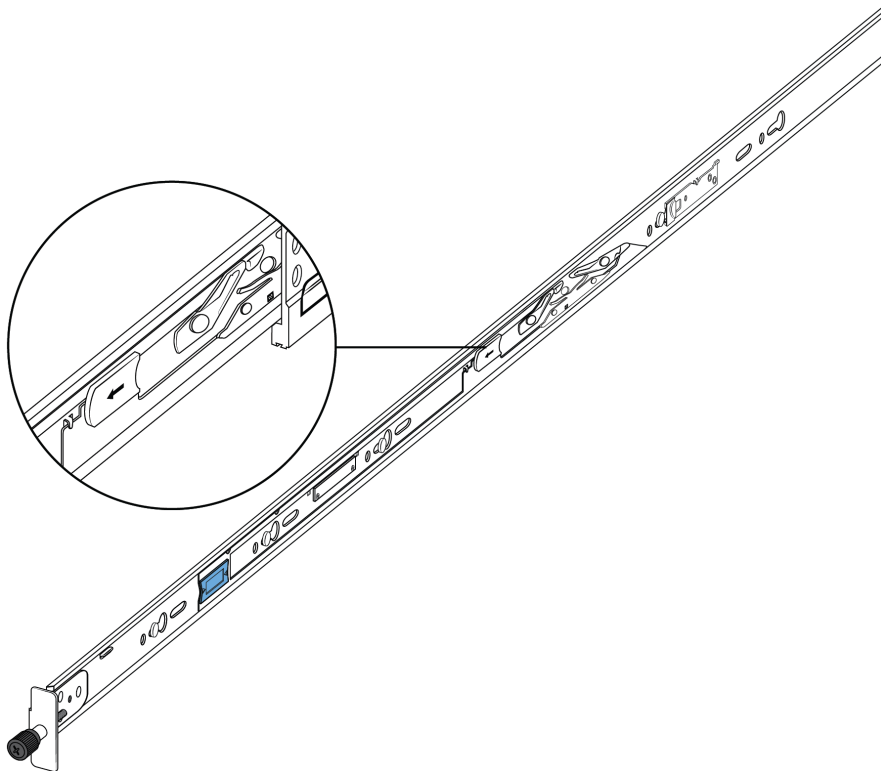


- 3 Use the following steps to detach the chassis rail from the slide's rack rail:
  - a Loosen the thumbscrew lock on the front of the rail.

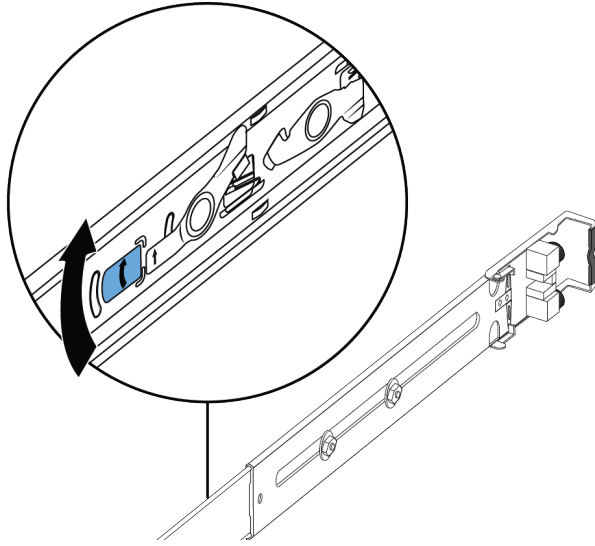
- b Pull the inner chassis rail and slide it out as far as you can.



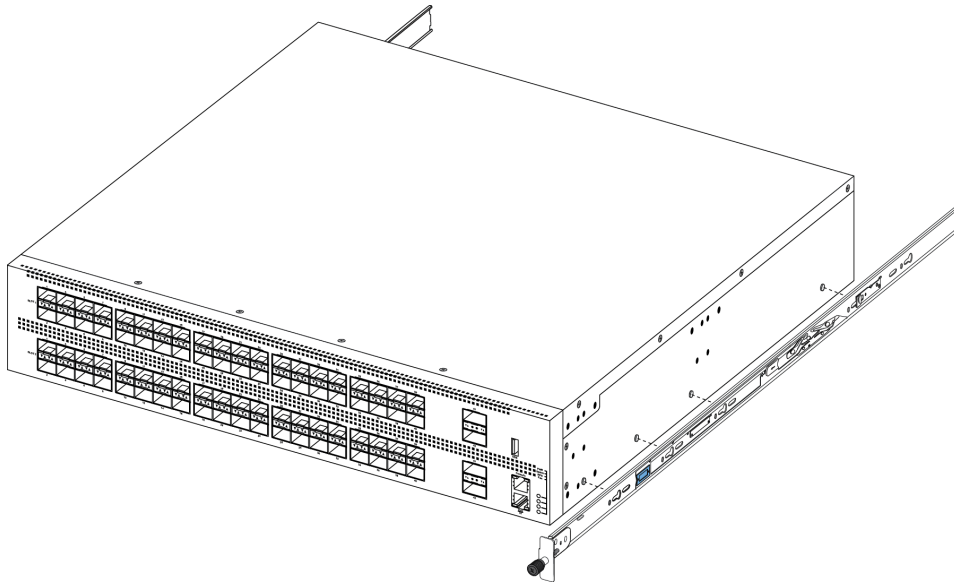
- c Slide the white release latch in the direction of the arrow stamped on the lock and pull the chassis rail out of the rack rail.



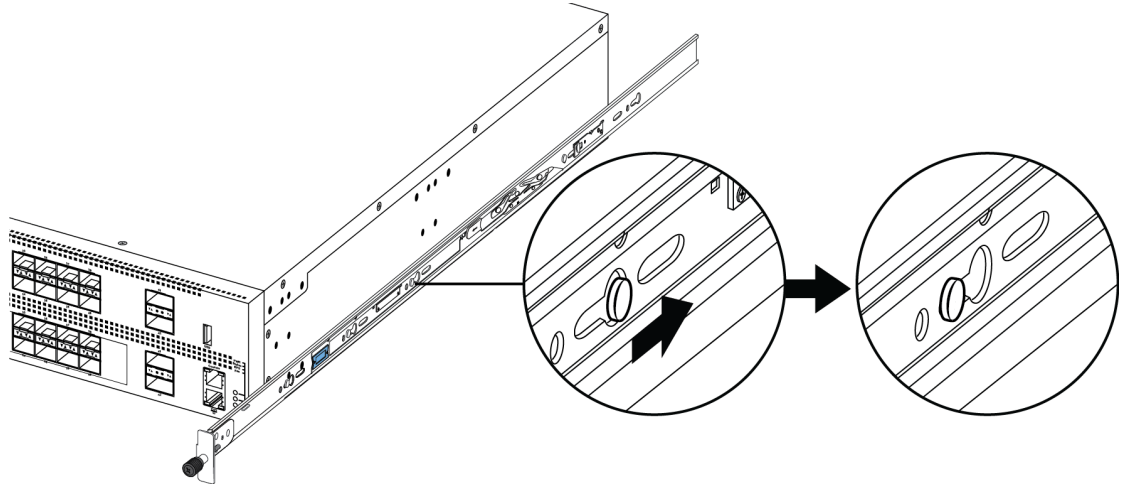
- 4 Lift the blue locking mechanism on the rack rail to slide the outer section back into the main section.



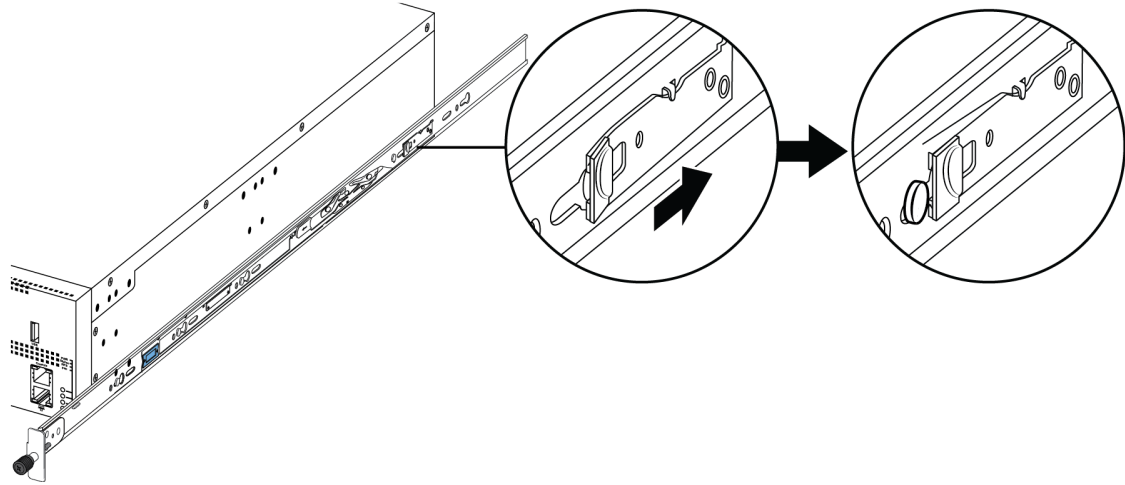
- 5 Use the following steps to attach the chassis rail to the chassis:
  - a Orient the chassis rail with the thumbscrew lock towards the front and position the rail over the standoffs on the chassis.



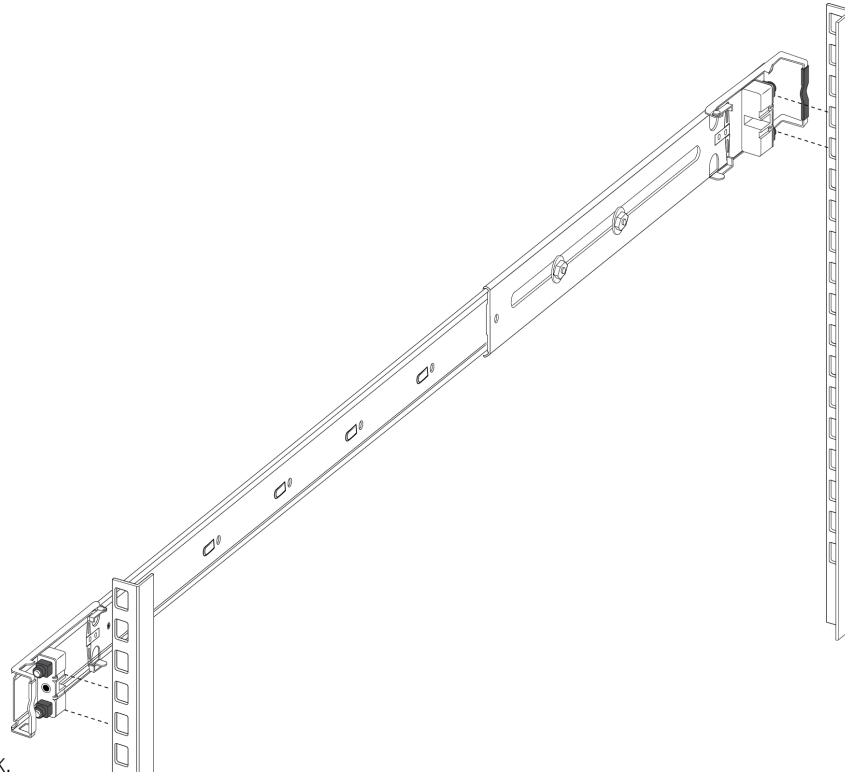
- b Slide the chassis rail to the rear until the rail locks into the standoffs.



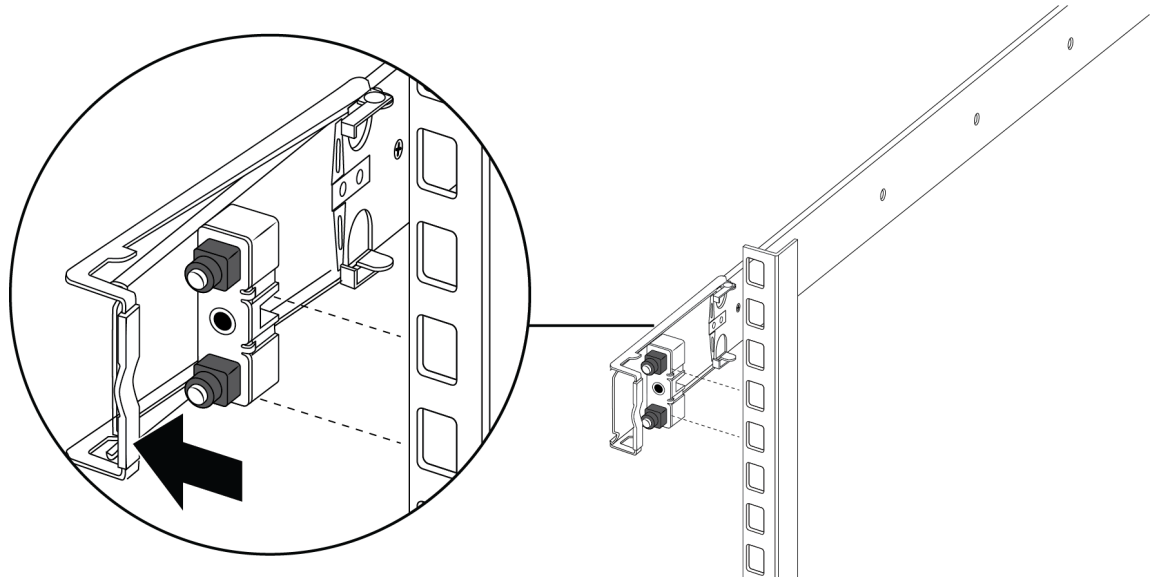
- c Make sure the safety tab locks into place.



- 6 Use the following steps to secure the rack rails to the frame:
  - a Orient the rack rail so that the end with the black retaining latch is facing front.
  - b Adjust the length of the rack rail so it fits the rack depth by loosening the two screws on the rack rail and adjusting the length. Make sure the screws are tight before you install the slides in the

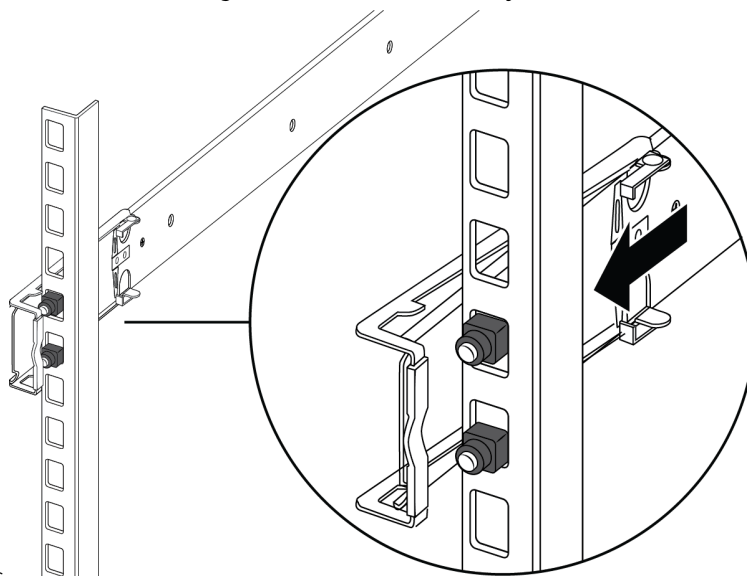


- c Push the end of the retaining latch out so it opens up.



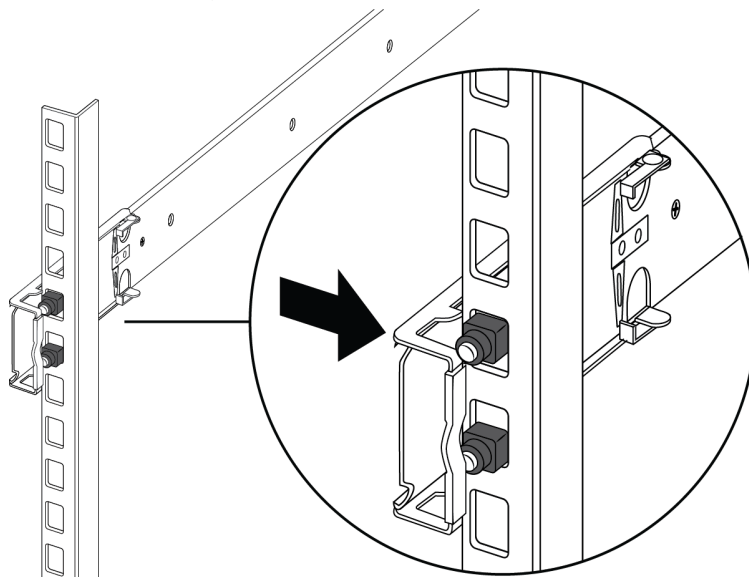


- d Insert the bracket pins into the desired holes in the frame. The pin block accommodates three different rack types. In the default position, the pin block fits into racks with square holes. When retracted halfway, it fits into racks with large round holes. When fully retracted, it fits into racks



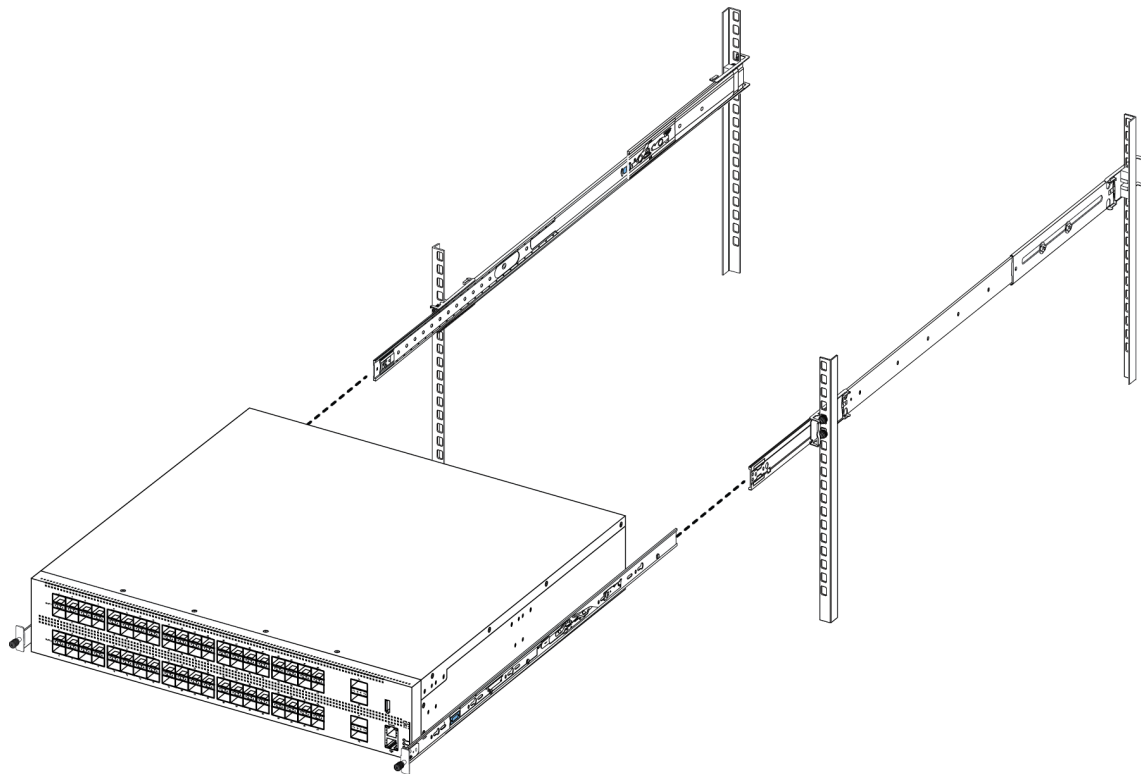
with small round holes.

- e Close the retaining latch so that it wraps around the frame and locks into place.

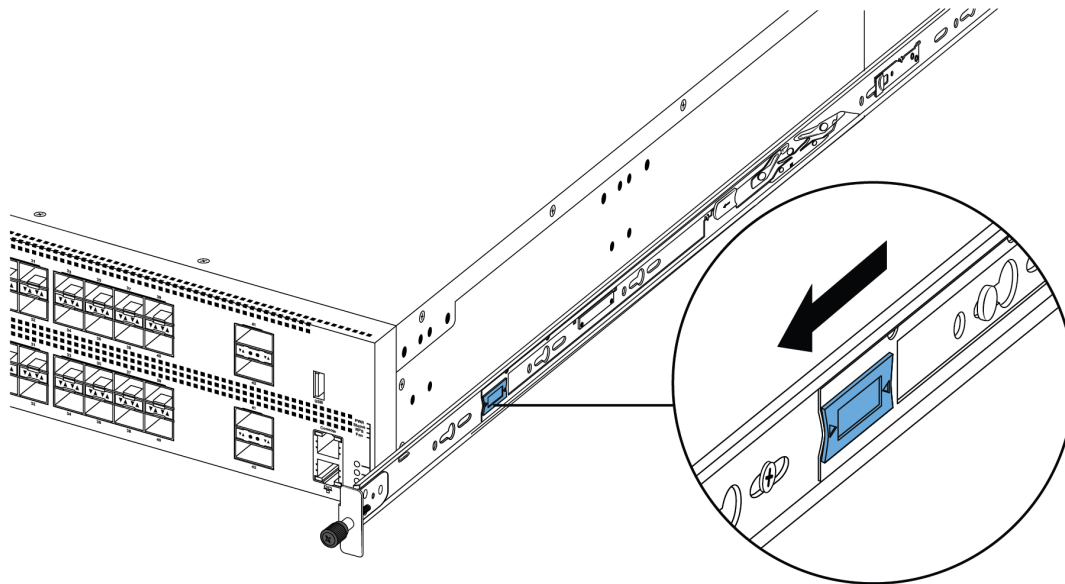


- f Repeat the above steps on the rear bracket.  
g Repeat these steps for the rack rail on the other side of the frame.

- 7 Use the following steps to install the switch in the equipment rack to complete the installation:
  - a Insert the chassis rails on the switch into the rack rails on the frame.

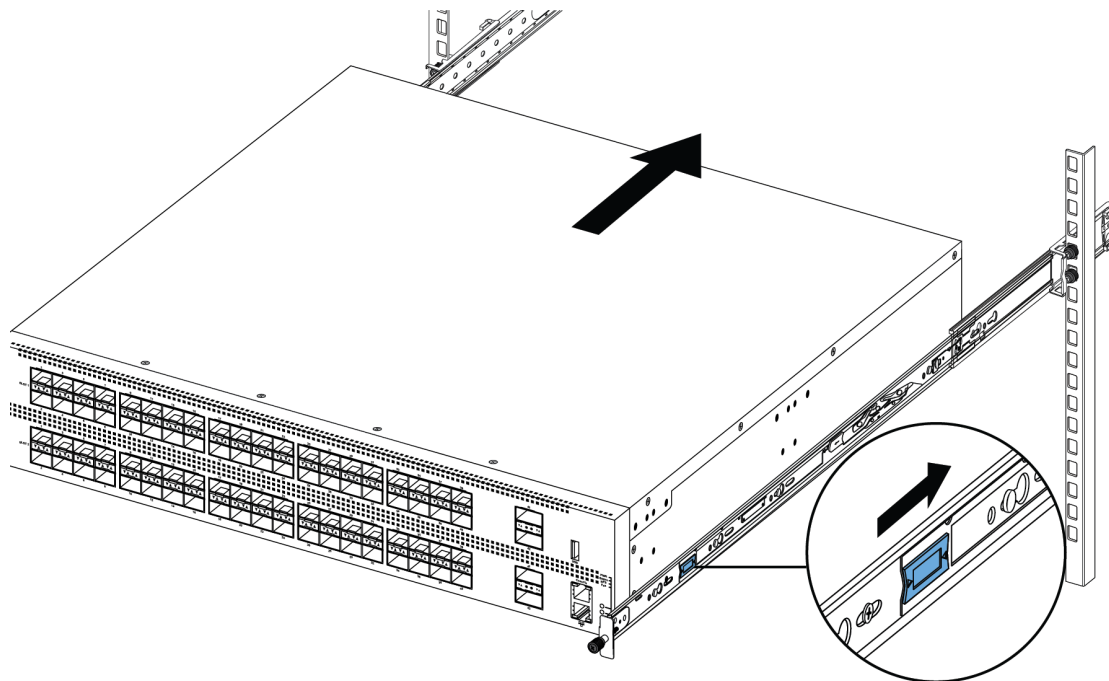


- b Pull the blue latches on the chassis rails towards the front and slide the switch into the frame.

**Note**

After you install the switch in a rack, slide it out until the lock (shown above) engages.

To slide the switch back into the rack, push the blue release latches on the chassis rails towards the back and slide the switch into the frame.



- 8 Connect power and network connections to the switch.

#### *Installing slides in a 600mm-900mm equipment rack*

Use the following procedure to install your switch in an equipment rack with a depth between 600mm and 900mm.

#### **Important**

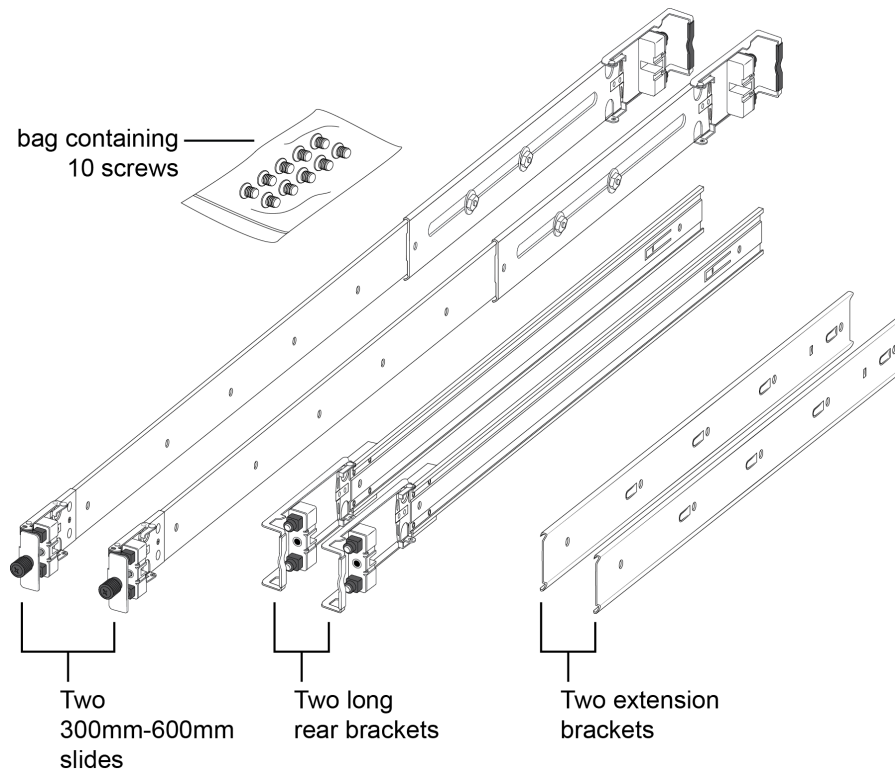


The Slide Rack Mount Kit is fairly complex due to its versatile design. To make your installation easier, read the [Inventory of slide components](#) section to familiarize yourself with the slide components and features.

- 1 Disconnect the power cord from the switch.

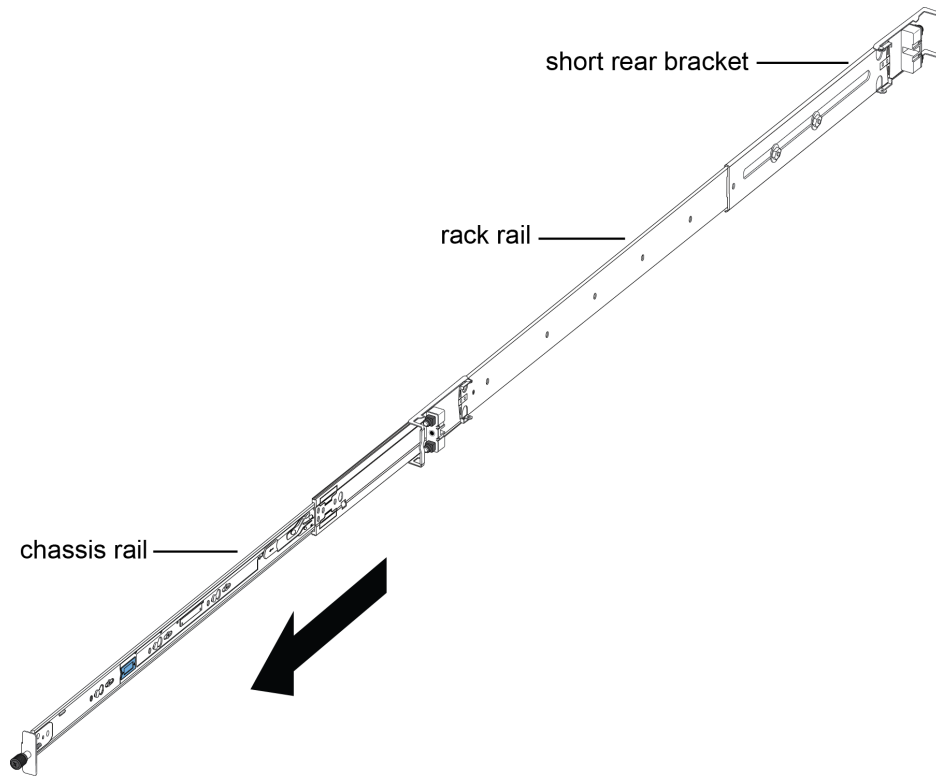
2 Open the shipping carton.

The 300mm-600mm slides are the default configuration. Use the remaining parts in the carton for converting the 300mm-600mm slides to 600mm-900mm slides.

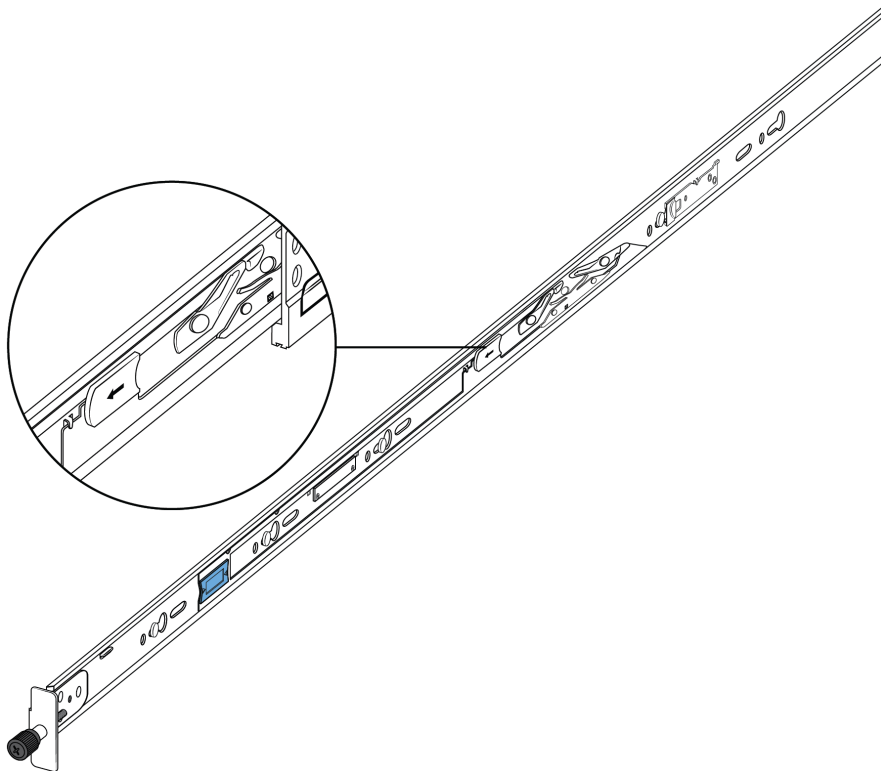


- 3 Use the following steps to detach the chassis rail from the slide's rack rail:
- Loosen the thumbscrew lock on the front of the rail.

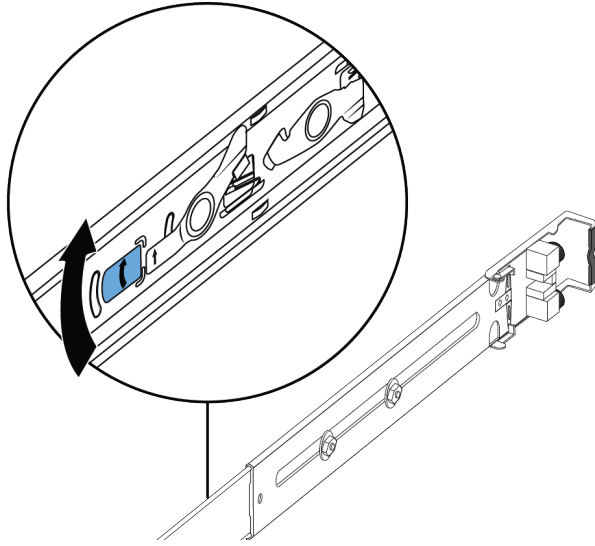
- b Pull the inner chassis rail and slide it out as far as you can.



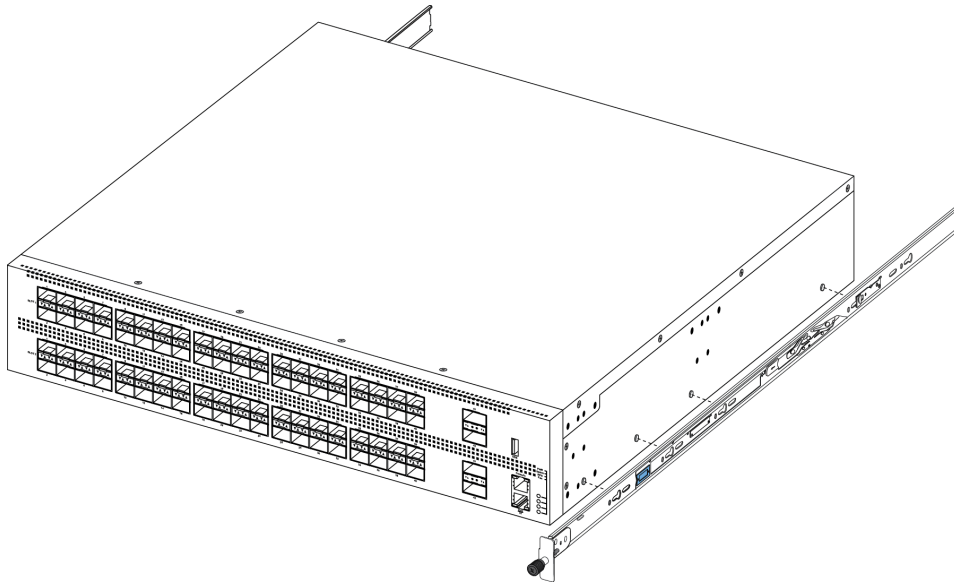
- c Slide the white release latch in the direction of the arrow stamped on the lock and pull the chassis rail out of the rack rail.



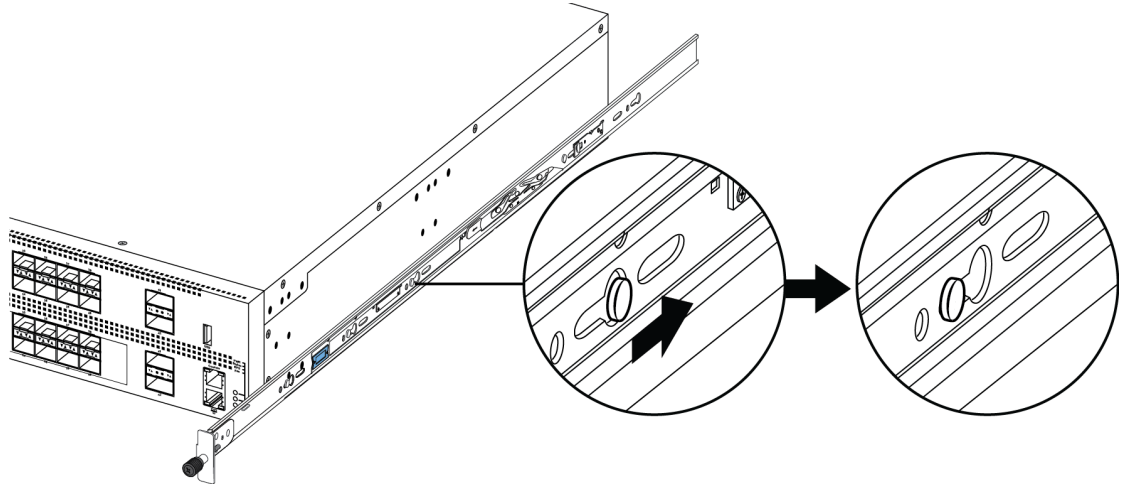
- 4 Lift the blue locking mechanism on the rack rail to slide the outer section back into the main section.



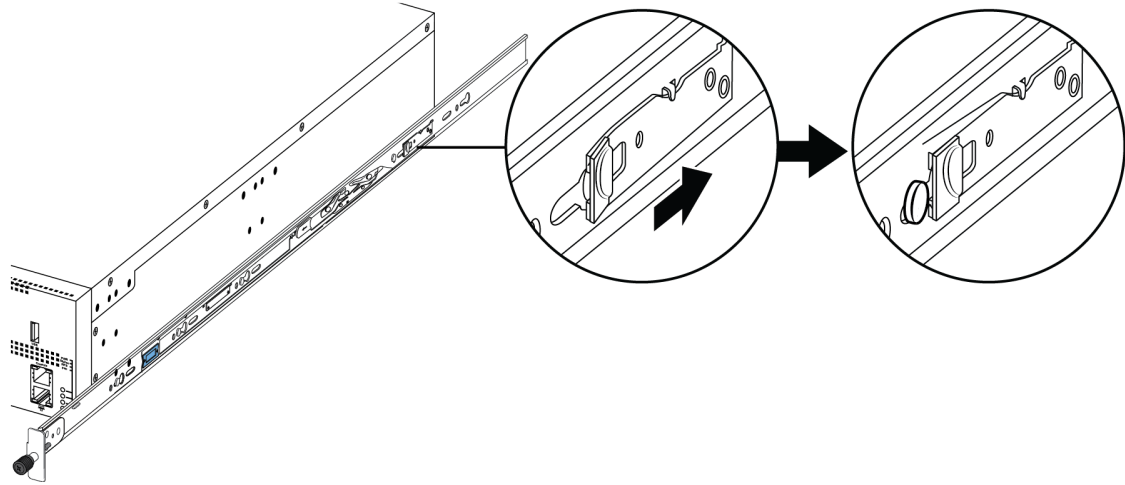
- 5 Use the following steps to attach the chassis rail to the chassis:
  - a Orient the chassis rail with the thumbscrew lock towards the front and position the rail over the standoffs on the chassis.



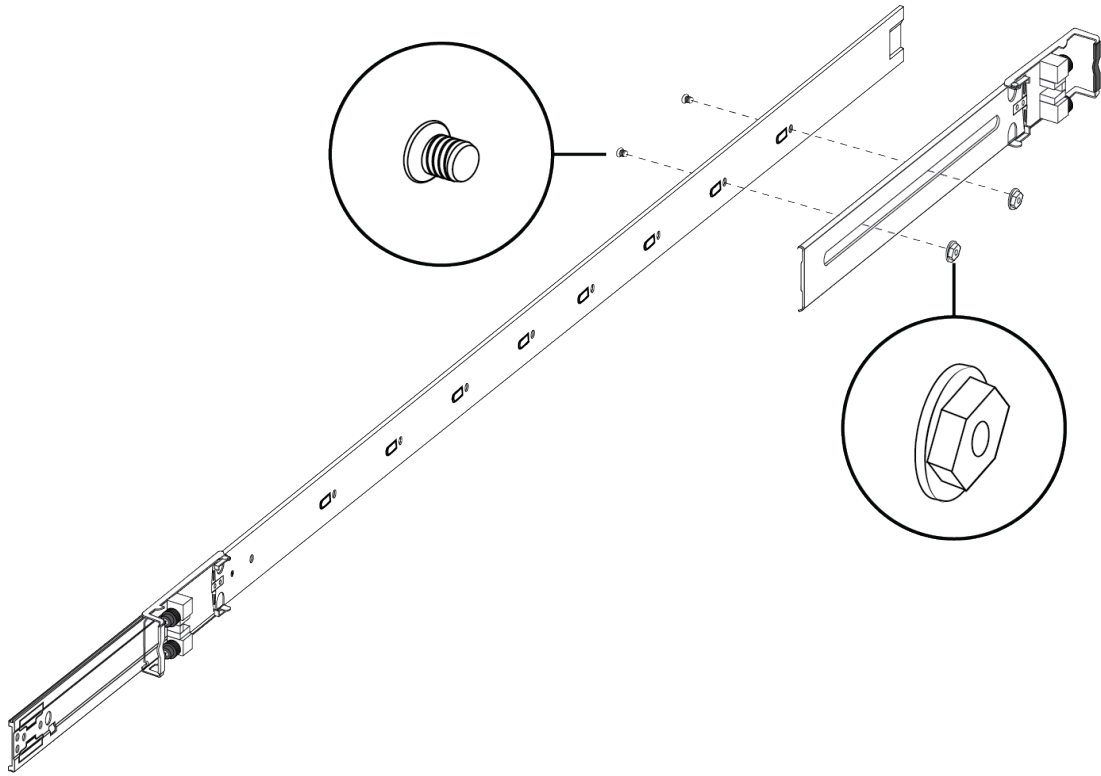
- b Slide the chassis rail to the rear until the rail locks into the standoffs.



- c Make sure the safety tab locks into place.

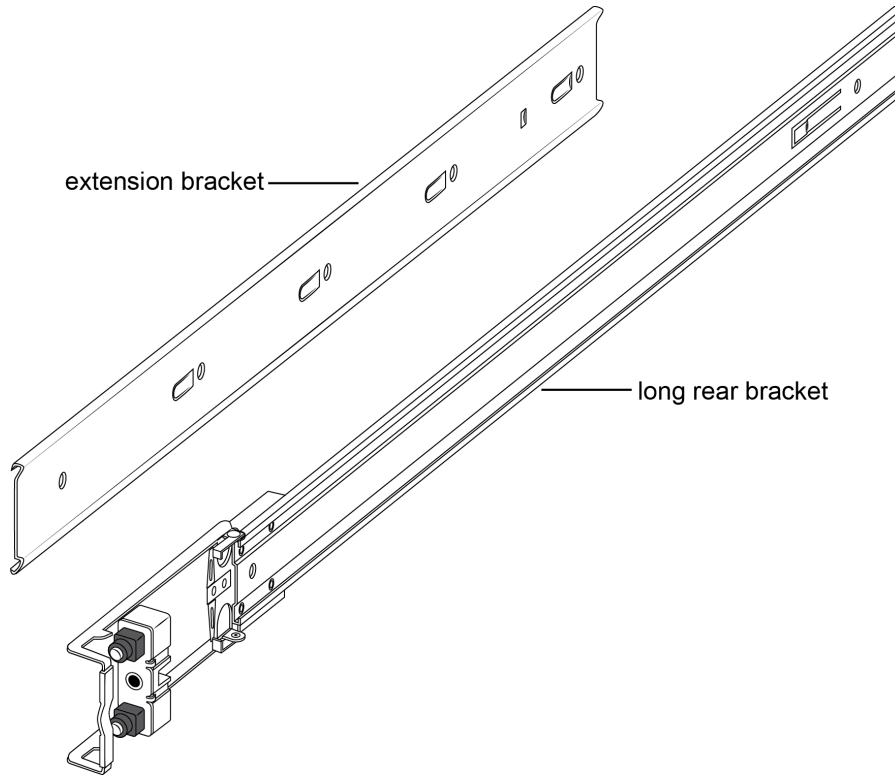


- 6 Remove the two screws and nuts securing the short rear bracket to the rack rail. This bracket is for 300mm-600mm equipment racks only and is not used in this installation. Save the bracket for possible future use.

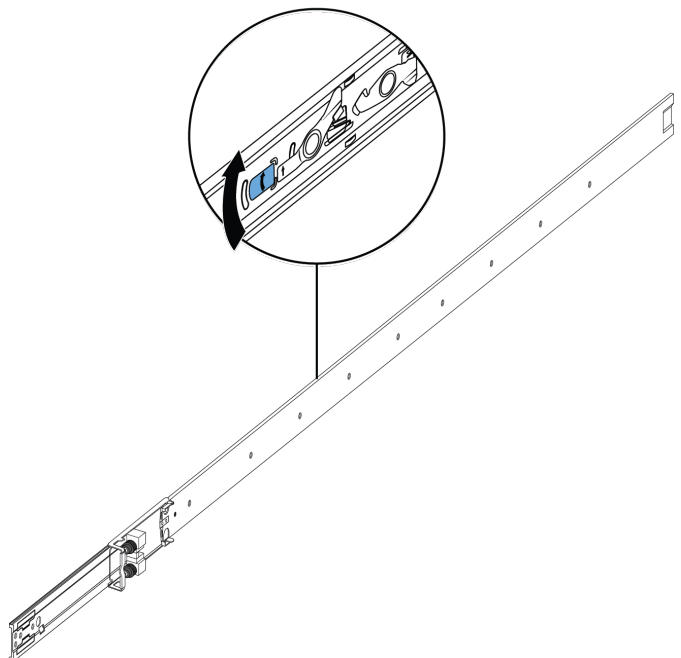




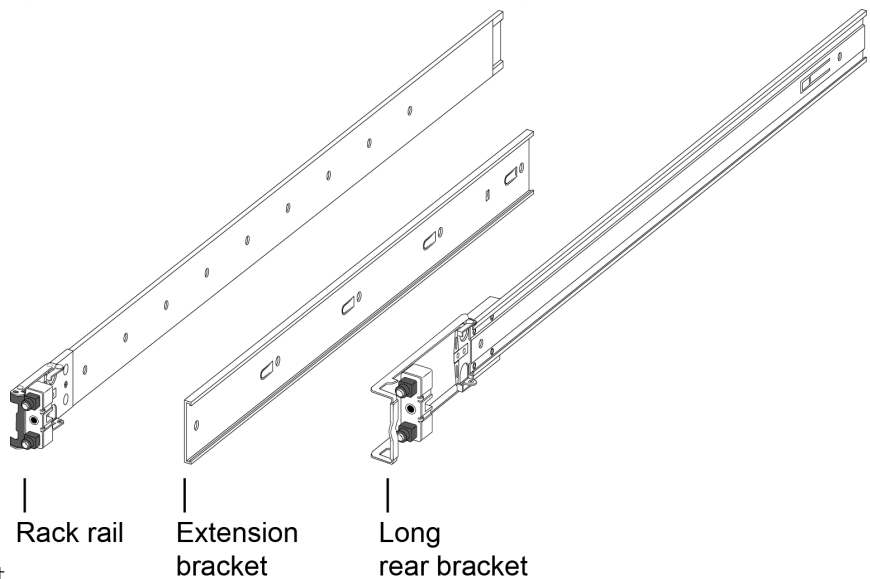
- 7 Identify the extension bracket and the long rear bracket. Use these brackets to extend the rack rail for 600mm-900mm racks.



- 8 Use the countersink screws with the following steps to attach the extension bracket to the rack rail:
  - a Push the blue release lock up and slide the middle rail out as far as possible.



- b Note the order and position of how the components are installed. The extension bracket (with the flat side down) goes on top of the rack rail and then the long rear bracket slides into the

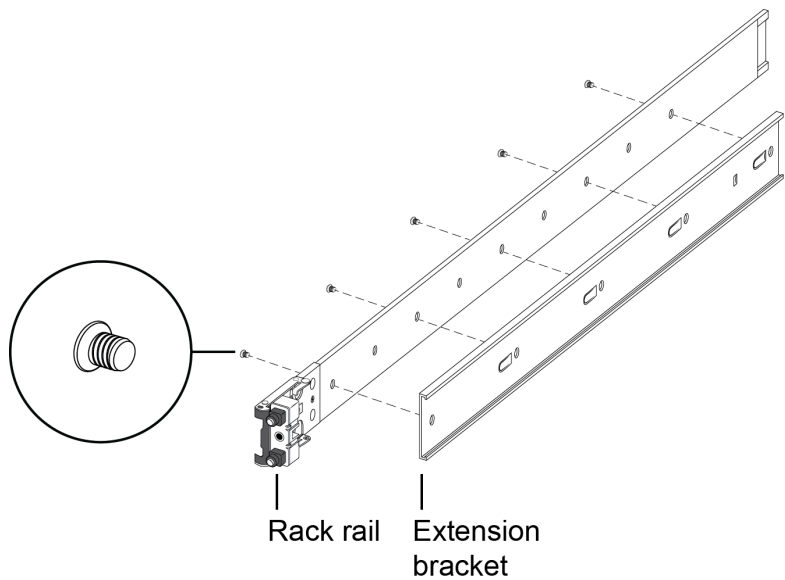


- extension bracket.
  - c Orient the extension bracket over the holes in the rack rail.

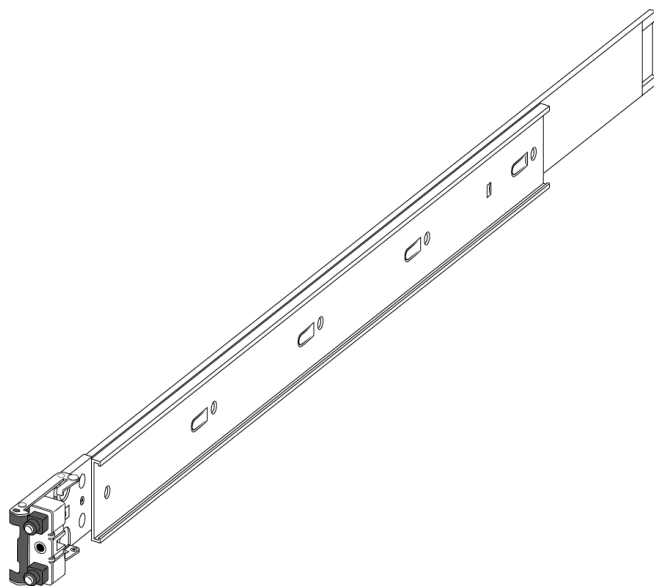


**Note**

Using the bag with ten M4 screws, attach the extension bracket to the rack rail by inserting the screws from the rack rail side and then into the extension bracket.



The following figure shows the extension bracket attached to the rack rail.



- d Insert the long rear bracket into the extension bracket assembly.

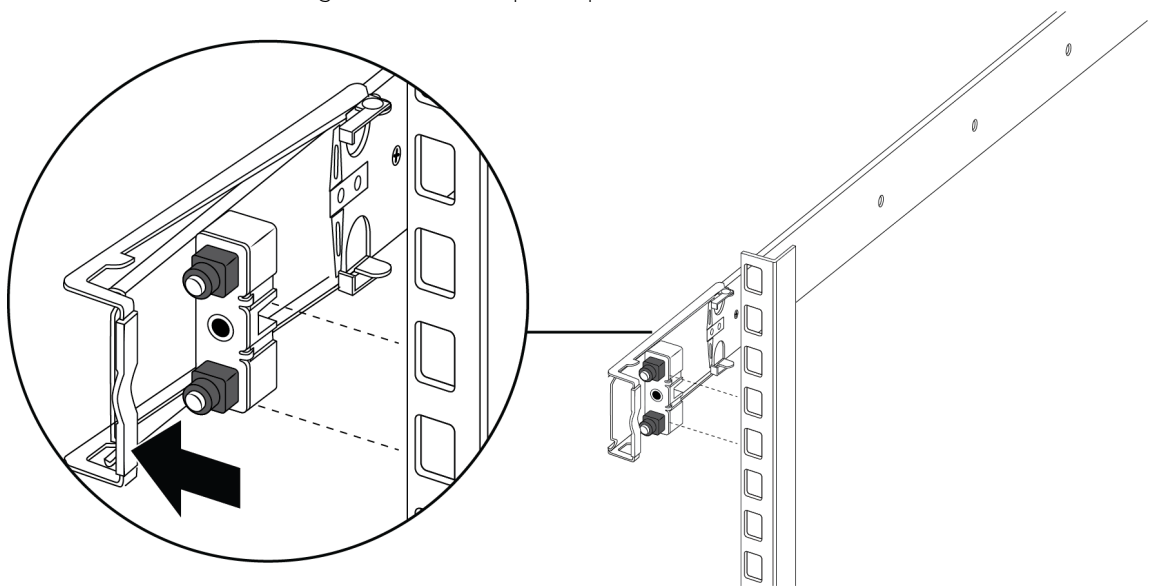


- e Install the first two screws on the end of the long rear bracket.
- f Lift the blue locking mechanism and slowly slide the rail back into the main assembly. This exposes a “window” over the screw holes so you can install the remaining three screws one at a

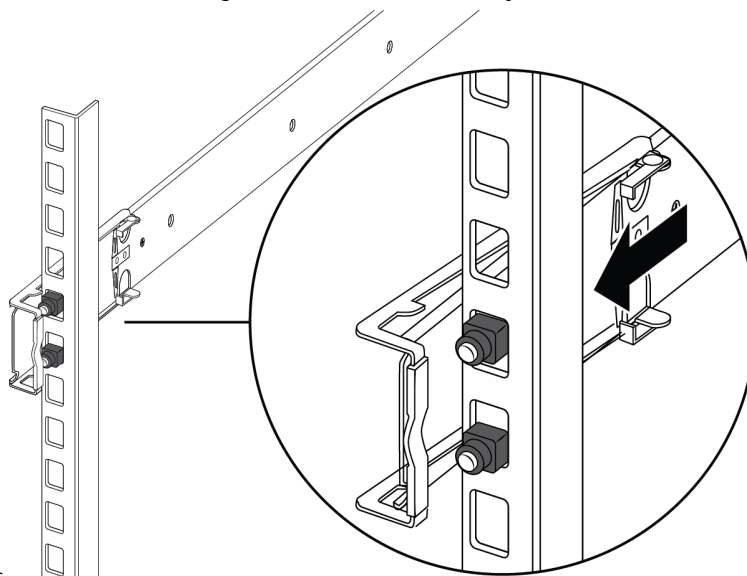


time.

- 9 Use the following steps to secure the rack rails to the frame:
  - a Orient the rack rail so that the end with the black retaining latch is in the front of the rack.
  - b Adjust the length of the rack rail so it fits the rack depth by sliding the long rear bracket into the extension bracket.
  - c Push the end of the retaining latch out so it opens up.

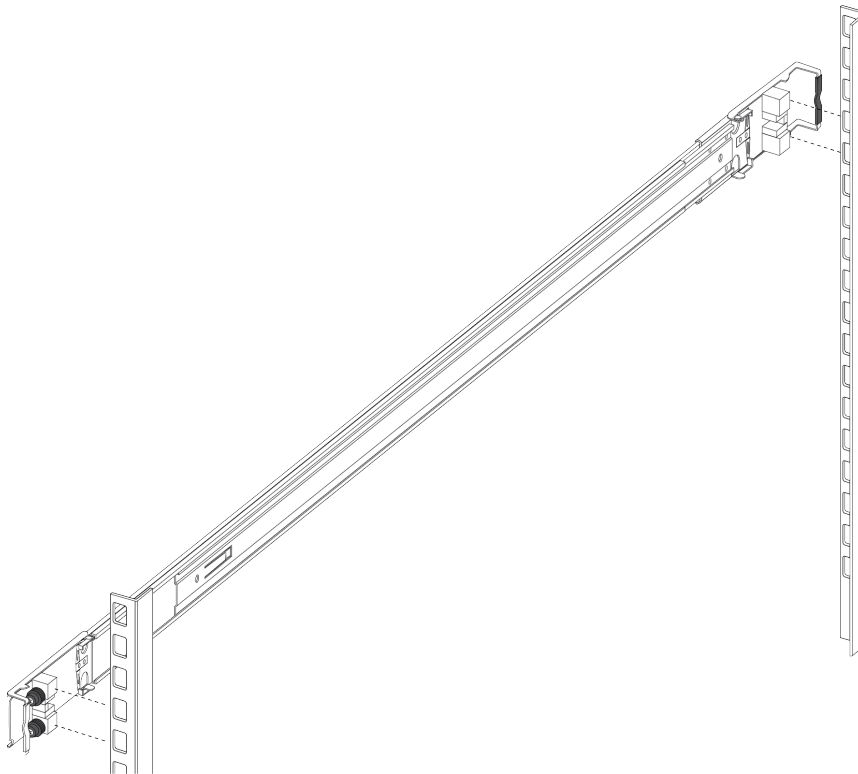


- d Insert the bracket pins into the desired holes in the frame. The pin block accommodates three different rack types. In the default position, the pin block fits into racks with square holes. When retracted halfway, it fits into racks with large round holes. When fully retracted, it fits into racks



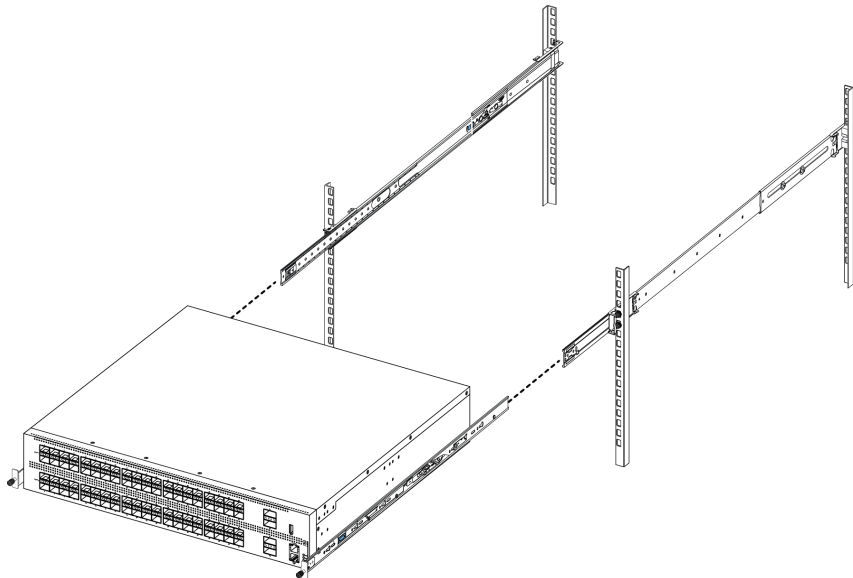
with small round holes.

- e Close the retaining latch so that it wraps around the frame and locks into place.

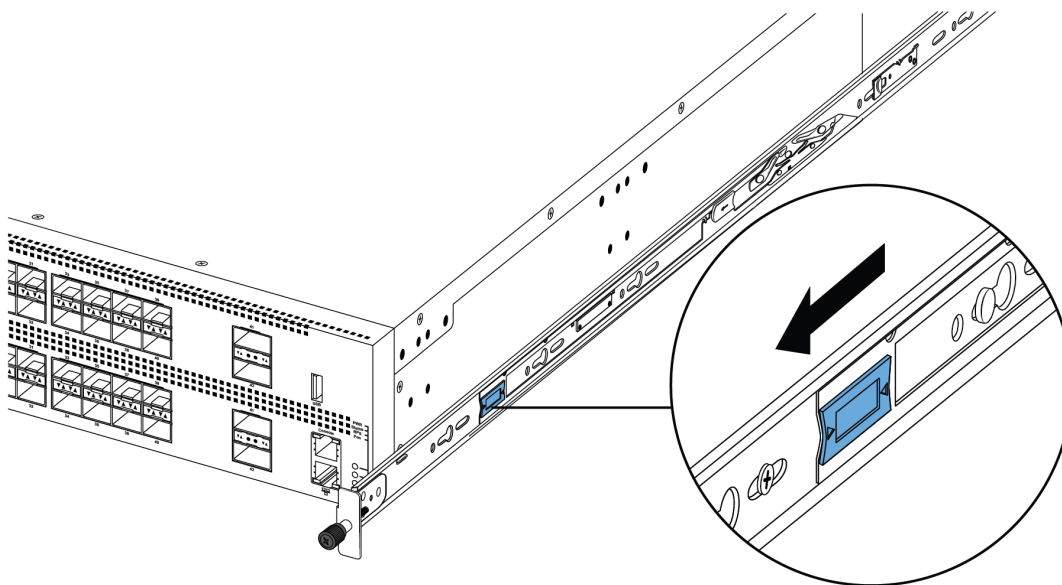


- f Repeat the above steps on the rear bracket.
- 10 Repeat these steps for the rack rail on the other side of the frame.

- 11 Use the following steps to install the switch in the equipment rack to complete the installation:
  - a Insert the chassis rails on the switch into the rack rails on the frame.



- b Pull the blue release latches on the chassis rails towards the front and slide the switch into the frame.

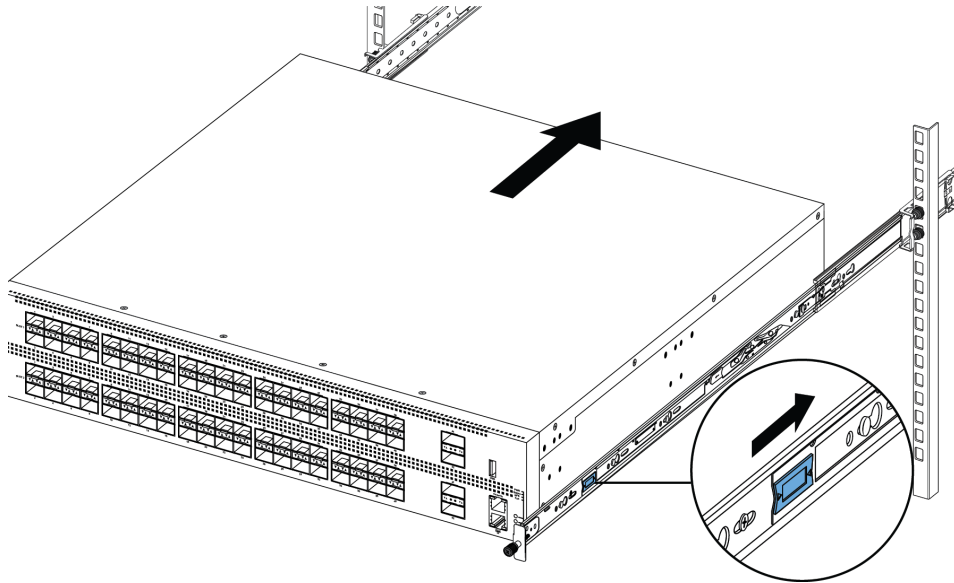


---

**Note**

After you install the switch in a rack, slide it out until the lock (shown above) engages. To slide the switch back into the rack, push the blue locks on the chassis rails towards the back and slide the switch into the frame.

---



12 Connect power and network connections to the switch.

#### *Important notice about rack safety*

One prerequisite to installing the switch in an equipment rack is to bolt the equipment rack to the floor. This section emphasizes the safety issue if you do not bolt the rack to the floor.

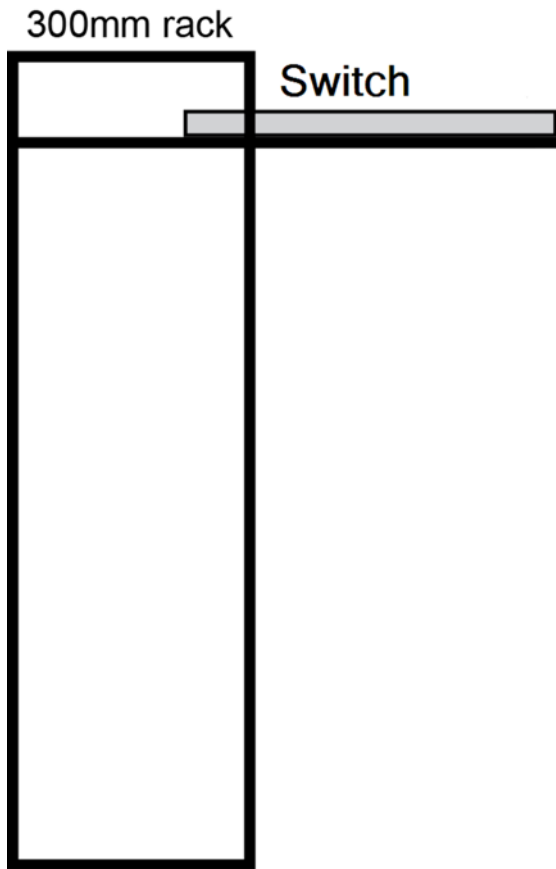
#### **Warning**



If you pull the chassis all the way out on the slide rails, there is a danger of the rack tipping over if the rack is not bolted to the floor. This can happen even if there are other devices installed in your equipment rack.

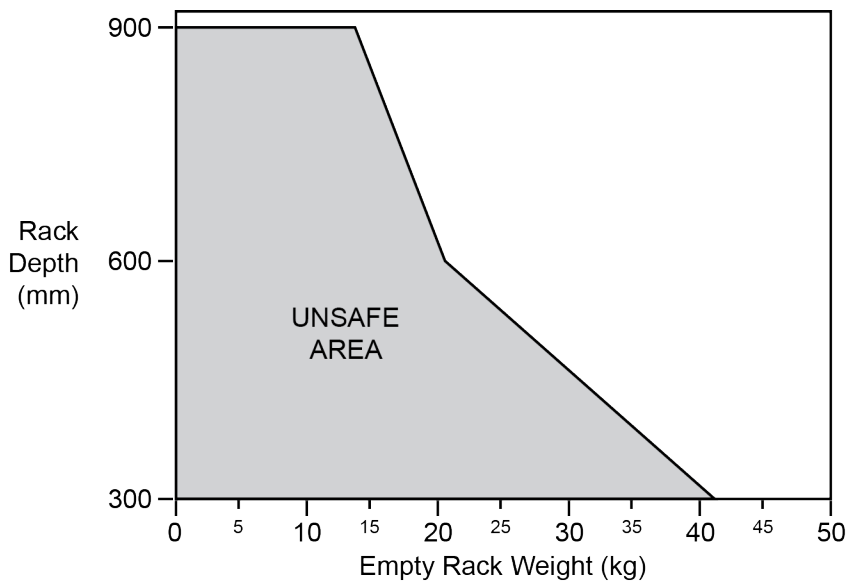
To avoid this danger, refer to the guidelines in the graph below the figure.





If your rack meets the following guidelines and you pull the chassis all the way out, the rack is in danger of tipping over:

- 900mm equipment rack that weighs less than 14kg
- 600mm equipment rack that weighs less than 21kg
- 300mm equipment rack that weighs less than 42kg



### Removing the switch from an equipment rack

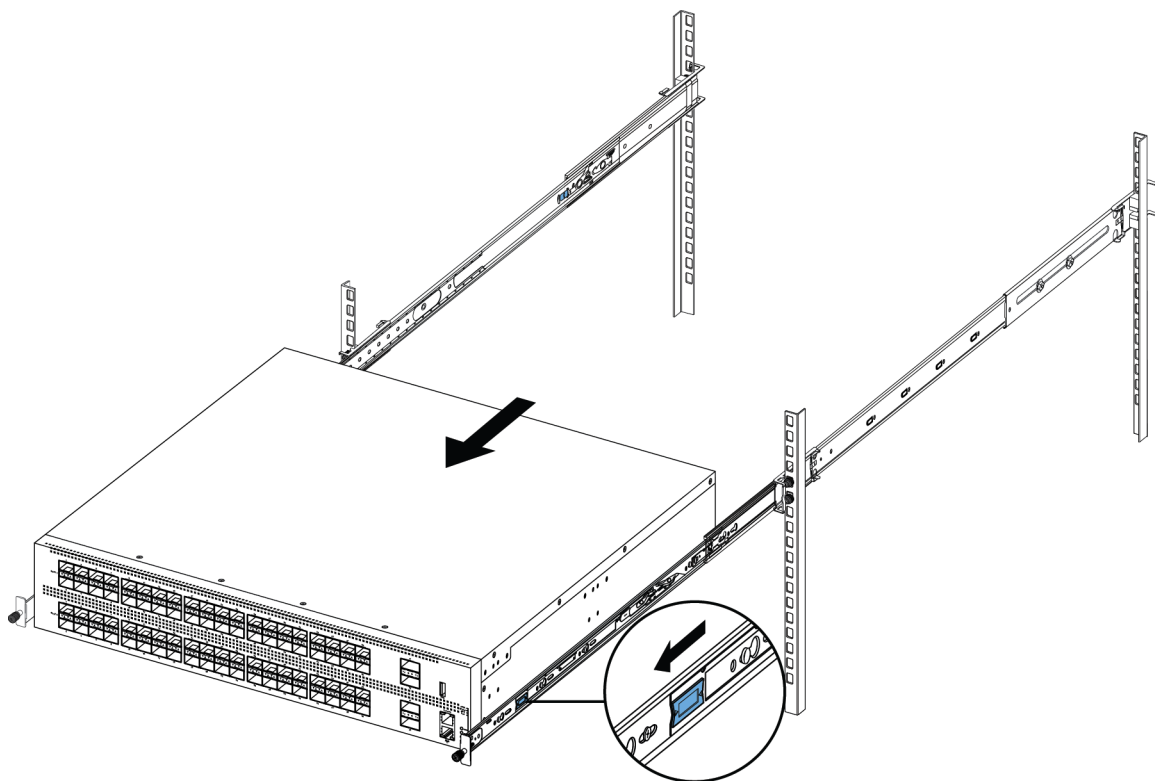
Follow these steps if you have to remove the switch from an equipment rack.



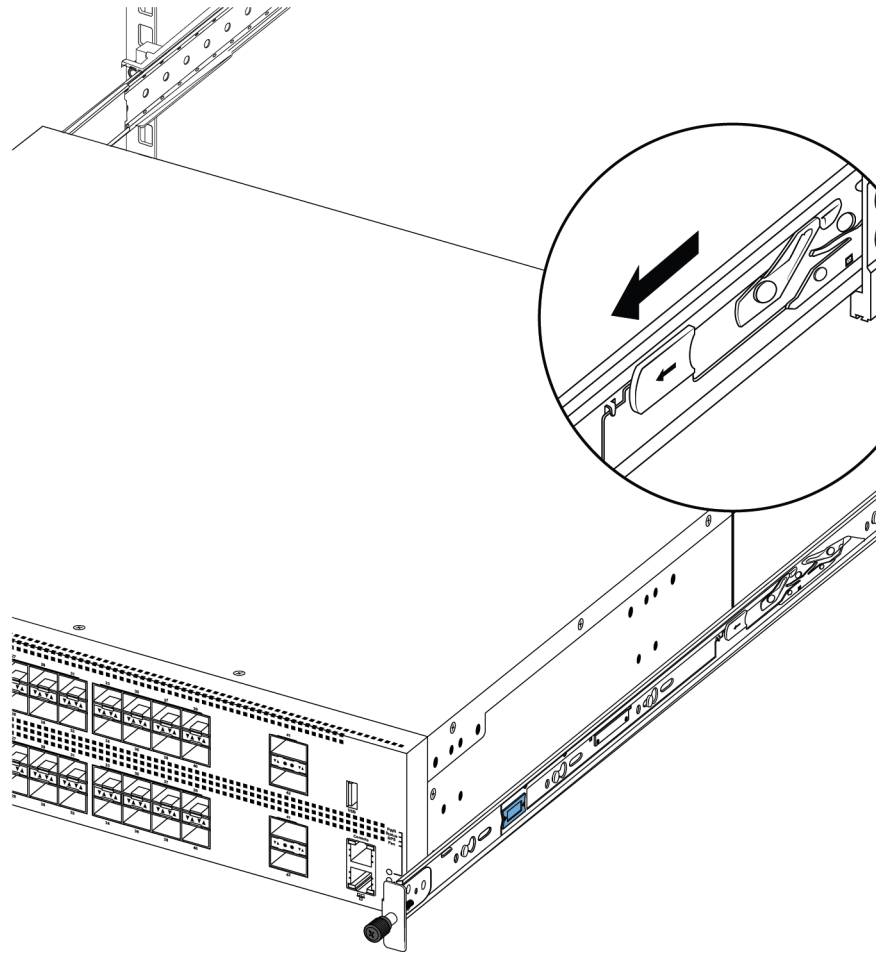
#### Important

This procedure requires two people.

- 1 Disconnect the power cord from the switch.
- 2 Slide the switch out until the lock engages.



- 3 While the person standing in back of the chassis slides both of the white release locks (one on each side of the chassis) towards the front, the person standing in front of the chassis pulls the chassis out of the rack.



## Using the supplied brackets

This procedure describes how to install the switch using the supplied brackets on a two-post or four-post equipment rack. The brackets secure the chassis and prevent it from sliding around during vibration or when inserting or extracting transceivers.

- If you have a two-post rack, install the brackets in the mid-chassis position.
- If you have a four-post rack, install the brackets in the front chassis position. In the front position, the switch should rest on a customer-supplied tray or shelf.



### Caution

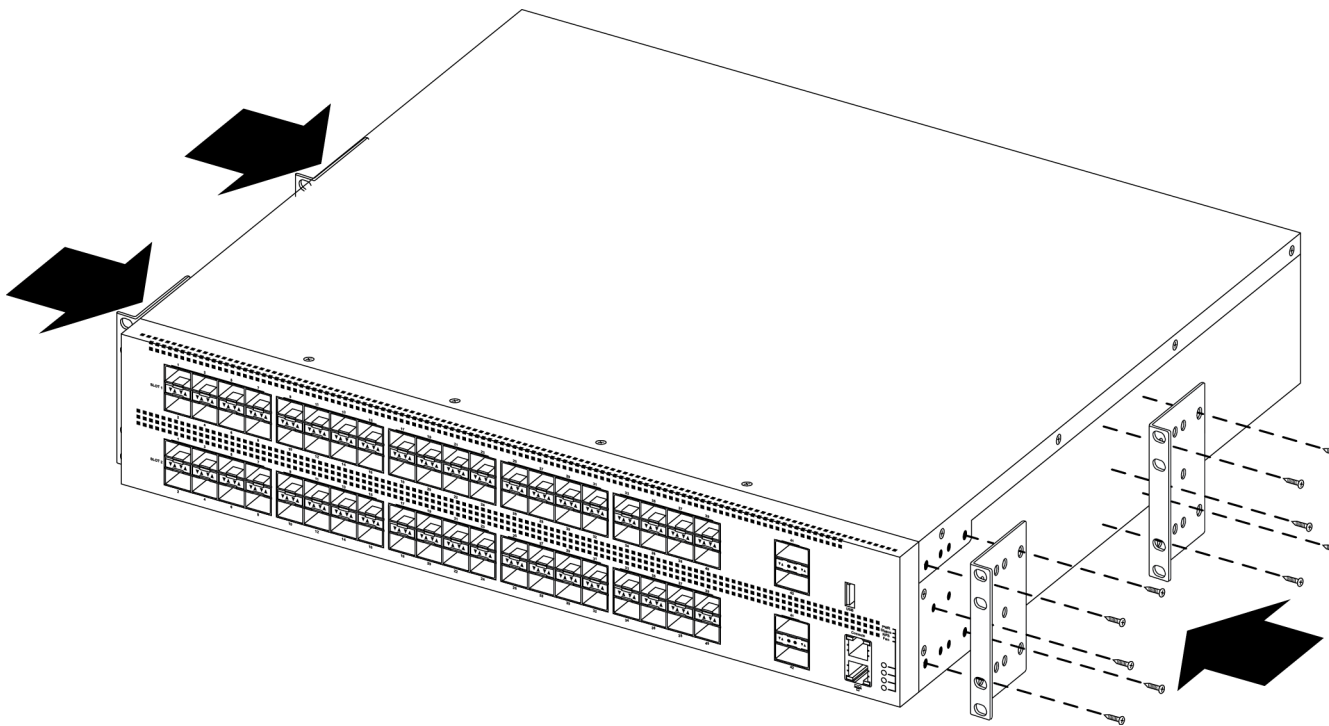
Do not mount the chassis with brackets in the front position without using a tray under the chassis. The chassis weight will cause damage to a rack when mounted by the front panel, especially in an environment with vibration or in an earthquake prone area.

- 1 Disconnect the power cord from the switch.

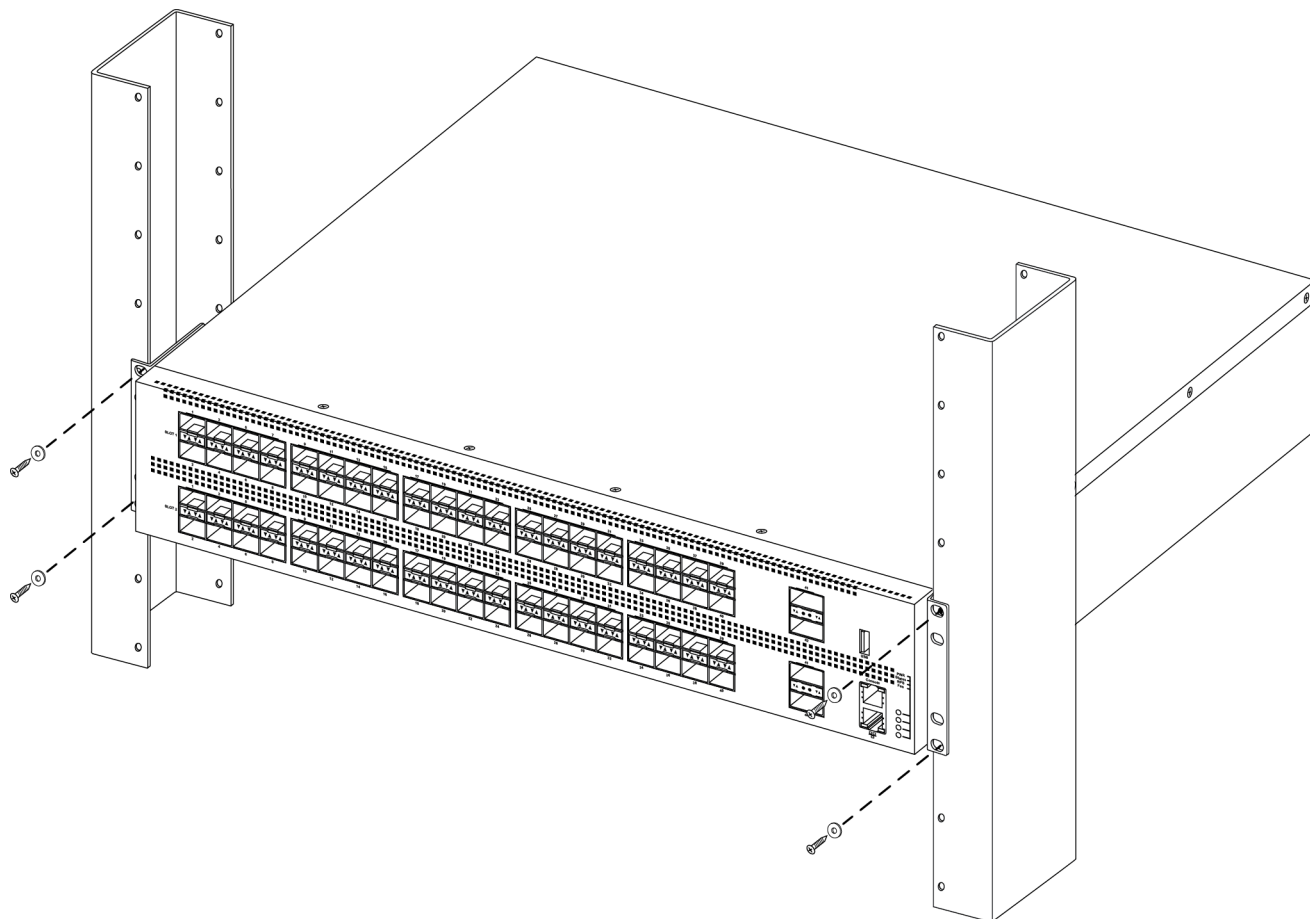
- 2 Attach a bracket to each side of the switch using a #2 Phillips screwdriver as illustrated below.

**Note**

The following figure shows the bracket position for a four-post rack installation. If you are installing the chassis in a two-post rack, attach the bracket in the location recessed 150 mm from the front of the chassis.



- Slide the switch onto a shelf or tray in the rack.



- Insert and tighten the rack-mount screws.
- Verify that the switch is securely fastened to the rack.
- Connect power and network connections to the switch.

## Cable requirements for the VSP 8000 Series

The following table describes the cables required for a VSP 8000 Series switch.

**Table 13: Switch cable requirements**

| Required Cable                   | Description                                                                                                                                                                                                                                                         |
|----------------------------------|---------------------------------------------------------------------------------------------------------------------------------------------------------------------------------------------------------------------------------------------------------------------|
| 10/100/1000BASE-TX Ports         | The interconnect cabling must conform to the Cat5e, Cat6, or Cat6e specification of the Commercial Building Telecommunications Cabling Standard, ANSI/TIA/EIA 568-B fitted with an RJ-45 Module jack.                                                               |
| Console Port (10101)             | Varies depending on the user device. The VSP 8000 Series switch has an RJ-45 female connector so a serial cable with an RJ-45 connector on one end and an RJ-45 on the other is appropriate. The maximum length for the console port cable is 25 feet (8.3 meters). |
| SFP+ and QSFP+ Transceiver Ports | Varies with the installed transceiver. See the documentation shipped with the transceiver for specifications.                                                                                                                                                       |

---

## Installation and removal of transceivers

---

The following sections describe how to install and remove transceivers in the VSP 8000 Series switch. In this context, the term *transceiver* refers to Small Form Factor Pluggable (SFP), SFP+, and Quad 4-channel SFP (QSFP+).

For more information about transceiver use and designation, see [Extreme Networks Pluggable Transceivers Installation Guide](#).

### Installing transceivers

Install transceivers by performing this procedure.

- 1 Remove the transceiver from the protective packaging.
- 2 Verify that the transceiver is the correct model for the network configuration.
- 3 Grasp the transceiver between your thumb and forefinger.
- 4 Insert the transceiver into the proper slot on the switch. Apply a light pressure to the transceiver until it clicks and locks into position.
- 5 Remove the dust cover from the transceiver optical bores.

### Removing transceivers

Remove transceivers by performing this procedure.

- 1 Disconnect the network fiber cable from the transceiver.
- 2 Use the locking mechanism on the transceiver to release it. The locking mechanism varies from model to model.
- 3 Slide the transceiver from the port.
- 4 If the transceiver does not slide easily from the port, use a gentle side-to-side rocking motion while firmly pulling the transceiver from the port.
- 5 Attach a dust cover over the fiber-optic bores and store the transceiver in a safe place until you need it.

**Note**

Discard transceivers in accordance with the proper laws and regulations.


---

## Console port pin assignments

---

The following section describes the console port pin assignments for the RJ-45 connectors in the VSP 8000 Series. The Console port and Management port both use RJ-45 connectors.

**Table 14: Console port pin assignments**

| Connector                                                                         | Pin Number | Signal                                                            |
|-----------------------------------------------------------------------------------|------------|-------------------------------------------------------------------|
|  | 1          | Ready to send (RTS) – optional                                    |
|                                                                                   | 2          | Data terminal ready (DTR) – optional, can swap or link with pin 8 |
|                                                                                   | 3          | Transmit data (TXD) – mandatory                                   |
|                                                                                   | 4          | Carrier detect (DCD) – optional                                   |
|                                                                                   | 5          | Ground (GND) – mandatory                                          |
|                                                                                   | 6          | Receive data (RXD) – mandatory                                    |
|                                                                                   | 7          | Data set ready (DSR) – optional                                   |
|                                                                                   | 8          | Clear to send (CTS) – optional, can swap or link with pin 1       |

**Note**

Table 14 shows only the console signalling.

## AC Power Supply

### Installing an AC power supply

**Important**

Installing a combination of AC-input and DC-input power supplies in the same chassis is not supported.

The VSP 8000 Series supports two field-replaceable 800W power supplies. One comes with the switch and you can install a second power supply to provide redundancy and load sharing.

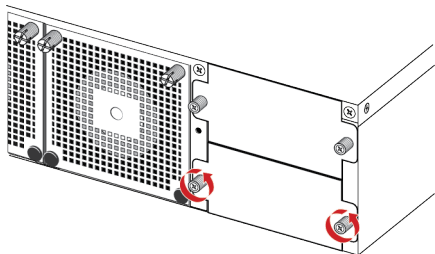
There are two power supply slots (PSU1 on top and PSU2 on the bottom).

- If you only have one power supply, you can install it in either PSU1 or PSU2.
- If you install a second power supply, neither one acts as a primary power supply. The two power supplies load share equally.
- If you are replacing an installed power supply, see [Removing a power supply](#).
- Remove the power cord before installing or removing the power supply.

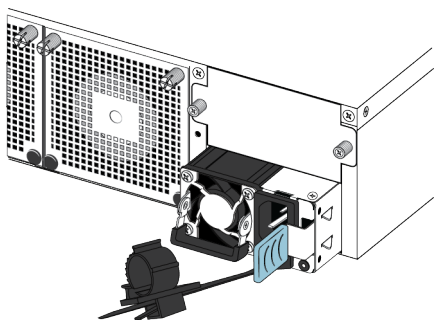
**Note**

The design of the latch mechanism that secures the power supply enforces this safety practice.

- 1 Remove the two screws that secure the filler panel to the chassis. (Save the filler panel for possible future use.)



- 2 Slide the power supply into the slot.



- 3 Verify that the power supply is fully seated in the slot. The spring latch should engage and return to its original position.



#### Note

The chassis design prevents an incorrect installation of a power supply. If you insert a power supply upside down, it will not fully insert.

- 4 Once you install a power supply, you can connect the AC power cord to the power supply on the back of the switch, and then connect the cord to an AC power outlet.

#### Important



The VSP 8000 Series does not have an AC power switch. When you connect the power cord to a power supply and connect the cord to an AC power outlet, the switch powers up immediately. To verify that the power supply is operating, check the LED on the bottom right side of the power supply. Solid green indicates that power is on. If it is off, check the connections.



#### Warning

Disconnecting the AC power cord is the only way to turn off AC power to the VSP 8000 Series. Allow at least 30 seconds for the VSP 8000 Series to fully power down before restoring power. Otherwise, the VSP 8000 Series might produce a core file during the reset leading to an extra delay during boot time. Always connect the AC power cord in a location that is quickly and safely accessible in case of an emergency. For a translation of this statement, see [Translations of safety messages](#) on page 89.



- 5 Check the LED on the bottom right side of the power supply. If it is off, the power supply is not operating. If it is green, the power supply is operating normally.

---

#### Important



You can hot swap power supplies while the switch is operational. One power supply is required for continued switch operation.

---

## AC power supply specifications

The VSP 8000 Series comes with an 800 W AC power supply and you can install a secondary power supply for redundancy.

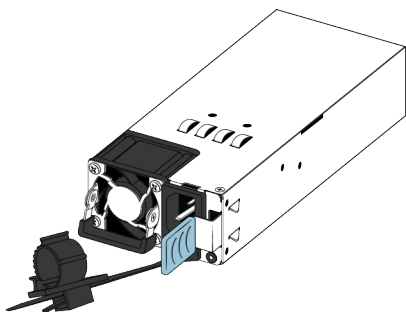
---

#### Important



You must have either a power supply or a power supply cover in each bay to ensure proper ventilation. Leaving a power supply bay unpopulated or uncovered impairs the ability of the fans to cool the chassis.

---



**Figure 23: AC power supply**

The 800 W AC power supply uses an IEC 60320 C14 AC power cord connector. The AC power cord is in close proximity to the hot air exhaust, and supports high operating temperatures.

The following table describes the regulatory AC power specifications for the VSP 8000 Series. Note that regulatory power specifications are based on the maximum rated capacity of the power supplies and are not based on typical power consumption, which is typically lower.

**Table 15: AC power specifications**

|                      | VSP 8000 Series                                |
|----------------------|------------------------------------------------|
| Input Current:       | 9.9–4.79 A                                     |
| Input Voltage (rms): | 100–240 V, 47–63 Hz                            |
| Power Consumption:   | 800 W maximum                                  |
| Thermal Rating:      | 2730 BTU/Hr maximum                            |
| Inrush Current:      | 40 A maximum                                   |
| Turn on Condition:   | 1 second maximum after application of AC power |





**Table 15: AC power specifications (continued)**

| VSP 8000 Series                                                                                                                                              |                    |
|--------------------------------------------------------------------------------------------------------------------------------------------------------------|--------------------|
| <b>Important:</b><br>12 V output rise time, from 10 to 90 percent, must be the maximum of 50 ms and monotonic under all defined input and output conditions. |                    |
| <b>Efficiency:</b>                                                                                                                                           | 70 percent minimum |

### AC power cord specifications

To connect AC power to the switch, you need an appropriate AC power cord as described in the following table, also see the following table for plug specifications.

**Table 16: International power cord specifications**

| Country and Plug Specification                                                                                                                                                                                                     | Specifications                                                                                          | Typical Plug                                                                          |
|------------------------------------------------------------------------------------------------------------------------------------------------------------------------------------------------------------------------------------|---------------------------------------------------------------------------------------------------------|---------------------------------------------------------------------------------------|
| Continental Europe:<br><ul style="list-style-type: none"> <li>CEE7 standard VII male plug</li> <li>Harmonized cord (HAR marking on the outside of the cord jacket to comply with the CENELEC Harmonized Document HD-21)</li> </ul> | <ul style="list-style-type: none"> <li>220 or 230VAC</li> <li>50 Hz</li> <li>Single phase</li> </ul>    |    |
| United States of America, Canada, and Japan:<br><ul style="list-style-type: none"> <li>NEMA5-15P male plug</li> <li>UL-recognized (UL stamped on cord jacket)</li> <li>CSA-certified (CSA label secured to the cord)</li> </ul>    | <ul style="list-style-type: none"> <li>100 or 120VAC</li> <li>50-60 Hz</li> <li>Single phase</li> </ul> |  |
| United Kingdom:<br><ul style="list-style-type: none"> <li>BS1363 male plug with fuse</li> <li>Harmonized cord</li> </ul>                                                                                                           | <ul style="list-style-type: none"> <li>240VAC</li> <li>50 Hz</li> <li>Single phase</li> </ul>           |  |
| Australia:<br><ul style="list-style-type: none"> <li>AS3112-1981 male plug</li> </ul>                                                                                                                                              | <ul style="list-style-type: none"> <li>240VAC</li> <li>50 Hz</li> <li>Single phase</li> </ul>           |  |

**Danger**

**Using power cords with a proper grounding path**



Use only power cords that have a grounding path. Without a proper ground, a person who touches the switch is in danger of receiving an electrical shock. Lack of a grounding path to the switch can result in excessive emissions. For a translation of this statement, see

[Translations of safety messages](#) on page 89.



## DC Power Supply

### Installing a DC Power Supply



#### Important

Installing a combination of AC-input and DC-input power supplies in the same chassis is not supported.

The VSP 8000 Series supports two field-replaceable 800 W power supplies. One comes with the switch and you can install a second power supply to provide redundancy and load sharing.

There are two power supply slots (PSU1 on top and PSU2 on the bottom).

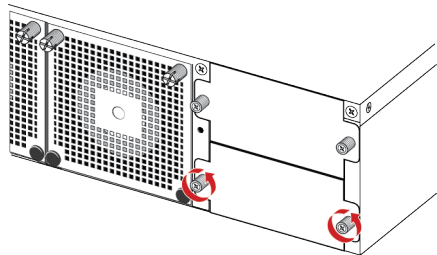
- If you only have one power supply, you can install it in either PSU1 or PSU2.
- If you install a second power supply, neither one acts as a primary power supply. The two power supplies load share equally.
- If you are replacing an installed power supply, see [Removing a power supply](#).
- Remove the DC power supply wiring assembly before installing or removing the power supply.



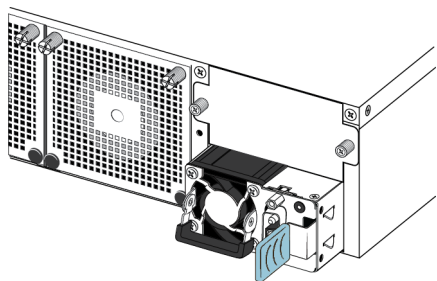
#### Note

The design of the latch mechanism that secures the power supply enforces this safety practice.

- 1 Remove the two screws that secure the filler panel to the chassis. (Save the filler panel for possible future use.)



- 2 Slide the power supply into the slot.



- 3 Verify that the power supply is fully seated in the slot. The spring latch should engage and return to its original position.



#### Note

The chassis design prevents an incorrect installation of a power supply. If you insert a power supply upside down, it will not fully insert.



#### Important

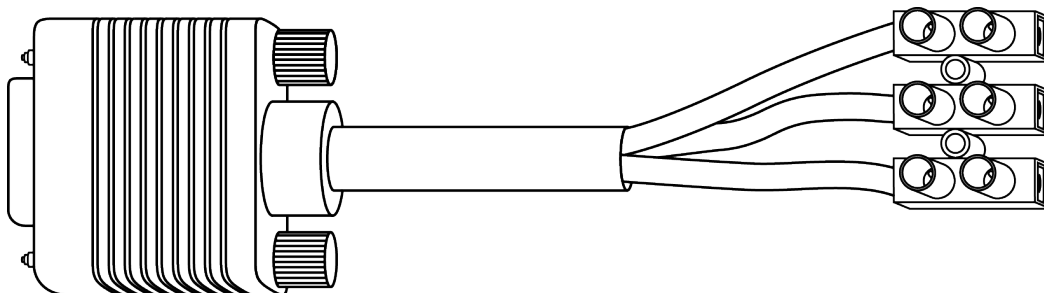
The VSP 8000 Series does not have a power switch. When you connect the DC power source to the DC power supply wiring assembly and then plug the assembly into the DC power supply, the switch powers up immediately.



#### Warning

Disconnecting the DC power supply wiring assembly from the power supply is the only way to turn off DC power to the VSP 8000 Series. Allow at least 30 seconds for the VSP 8000 Series to fully power down before restoring power. Otherwise, the VSP 8000 Series might produce a core file during the reset leading to an extra delay during boot time.

- 4 Once you install a power supply, use the following steps to connect the DC power supply wiring assembly:
  - a Extreme Networks supplies a DC power supply wiring assembly to connect the DC power supply to the DC input power source.



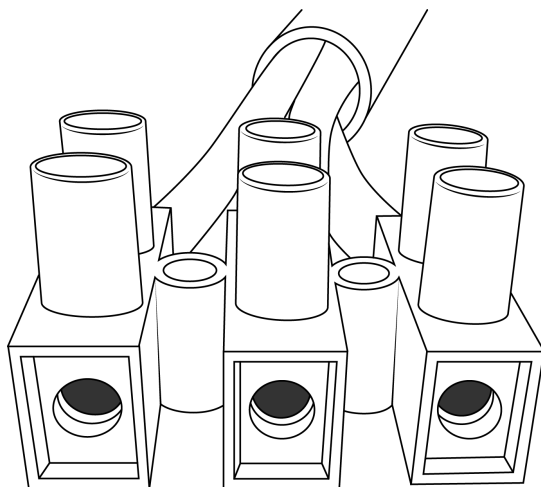
- b Strip 0.8 in. (2 cm) of insulation from the ends of the power source cables.
  - c Refer to the tag attached to the DC power supply wiring assembly to insert the cables into their appropriate connectors.



#### Warning

Ensure that the positive and negative power inputs are connected to the correct connectors and that the switch is properly grounded before connecting it to a power source.

- d Use a screwdriver to crimp the cables to the DC power supply wiring assembly.



- e Use a screwdriver to terminate the three raw wires to a DC power source.
- f Connect the DC power supply wiring assembly to the DC power supply and screw it in to secure the connection.
- 5 Check the LED on the top right side of the power supply. If it is off, the power supply is not operating. If it is green, the power supply is operating normally. The following table describes all the LED states.

**Table 17: DC power supply LED states**

| Color and Status | Description                                                                                                                                                                                                                                               |
|------------------|-----------------------------------------------------------------------------------------------------------------------------------------------------------------------------------------------------------------------------------------------------------|
| Off              | There is no DC power to either power supply.                                                                                                                                                                                                              |
| Green (steady)   | There is output and the power supply is operating normally.                                                                                                                                                                                               |
| Green (blinking) | The power supply is present, but its output is standby voltage (12VSB).                                                                                                                                                                                   |
| Amber (steady)   | SHUTDOWN: The power supply is not supplying power to the switch because the power cord is unplugged or the power supply shutdown for faults such as a fan failure or exceeding limits for Over Current Protection (OCP) or Over Voltage Protection (OVP). |
| Amber (blinking) | WARNING: The power supply continues to operate, but there are one or more warning events such as high temp, high power, high current, or a slow fan.                                                                                                      |



**Important**

You can hot swap power supplies while the switch is operational. One power supply is required for continued switch operation.

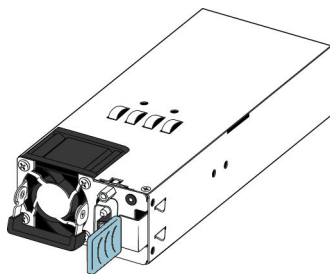
## DC power supply specifications

The VSP 8000 Series comes with one 800 W DC power supply and you can install a secondary power supply for redundancy.

### Important



You must have either a power supply or a power supply cover in each bay to ensure proper ventilation. Leaving a power supply bay unpopulated or uncovered impairs the ability of the fans to cool the chassis.



**Figure 24: DC power supply**

The 800 W DC power supply uses a DC power supply wiring assembly to connect the power supply to the DC power source.

The following table describes the regulatory DC power specifications for the VSP 8000 Series switch. Note that regulatory power specifications are based on the maximum rated capacity of the power supplies and are not based on typical power consumption, which is typically lower.

**Table 18: DC power specifications**

|                                                                                                                                                                      | VSP 8000 Series                                                                                                                                                                                               |
|----------------------------------------------------------------------------------------------------------------------------------------------------------------------|---------------------------------------------------------------------------------------------------------------------------------------------------------------------------------------------------------------|
| Input Current:                                                                                                                                                       | 24–16 A                                                                                                                                                                                                       |
| Input Voltage (rms):                                                                                                                                                 | 40.5 to 60 VDC                                                                                                                                                                                                |
| Power Consumption:                                                                                                                                                   | 800 W maximum                                                                                                                                                                                                 |
| Temperature:                                                                                                                                                         | Operating range: 0 to 50° C<br>Non-operating range: -40 to 70° C                                                                                                                                              |
| Inrush Current:                                                                                                                                                      | 50 A maximum                                                                                                                                                                                                  |
| Turn on Condition:                                                                                                                                                   | 500 milliseconds maximum after application of DC power                                                                                                                                                        |
| <p><b>Important:</b><br/>12 V output rise time, from 10 to 90 percent, must be the maximum of 70 ms and monotonic under all defined input and output conditions.</p> |                                                                                                                                                                                                               |
| Efficiency:                                                                                                                                                          | <ul style="list-style-type: none"> <li>• 88% minimum at 100% load level</li> <li>• 92% minimum at 50% load level</li> <li>• 88% minimum at 20% load level</li> <li>• 80% minimum at 10% load level</li> </ul> |



## Removing a power supply

You can hot swap power supplies while the switch is operational.

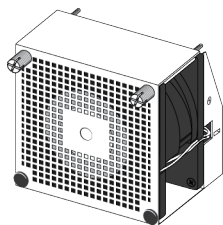
- 1 Disconnect the power cord from the power supply.
- 2 Lift up the power supply handle so you can grasp it.
- 3 Push the spring latch to the left and use the power supply handle to pull the power supply out of the chassis.
- 4 If you are replacing the power supply, see [Installing a power supply](#). If not, re-install the filler panel.

## Airflow direction

The airflow direction for the VSP 8200 Series and the VSP 8400 Series is front-to-back.

## Install a Fan Module

The VSP 8000 Series comes with four 12-V fan modules for switch cooling.



**Figure 25: Fan module**

There are four sensors inside the chassis that monitor the temperature. These sensors send information to a controller that automatically regulates the fan speed to maintain the proper temperature.

- If any sensor exceeds its threshold, an alarm is triggered and the log is generated in the format:

```
Temperature Sensor [CPU | MAC | PHY1 | PHY2] is ([value] C) has exceeded the alarm
threshold temperature ([value] C)
```



### Important

The system does not shutdown when it exceeds the threshold temperature.

- When the temperature cools by 2° below the threshold, the alarm clears and the log is generated in the format:

```
Temperature Sensor [CPU | MAC | PHY1 | PHY2] overheat temperature alarm cleared
```

The following table shows the types of sensors and the corresponding threshold values:

**Table 19: Sensor threshold values**

| Sensor name | Warning threshold | Critical threshold |
|-------------|-------------------|--------------------|
| CPU         | 45                | 55                 |
| MAC         | 50                | 60                 |

**Table 19: Sensor threshold values (continued)**

| Sensor name | Warning threshold | Critical threshold |
|-------------|-------------------|--------------------|
| PHY1        | 50                | 60                 |
| PHY2        | 50                | 60                 |

Use this procedure if a fan fails and you have to replace it.

### Important



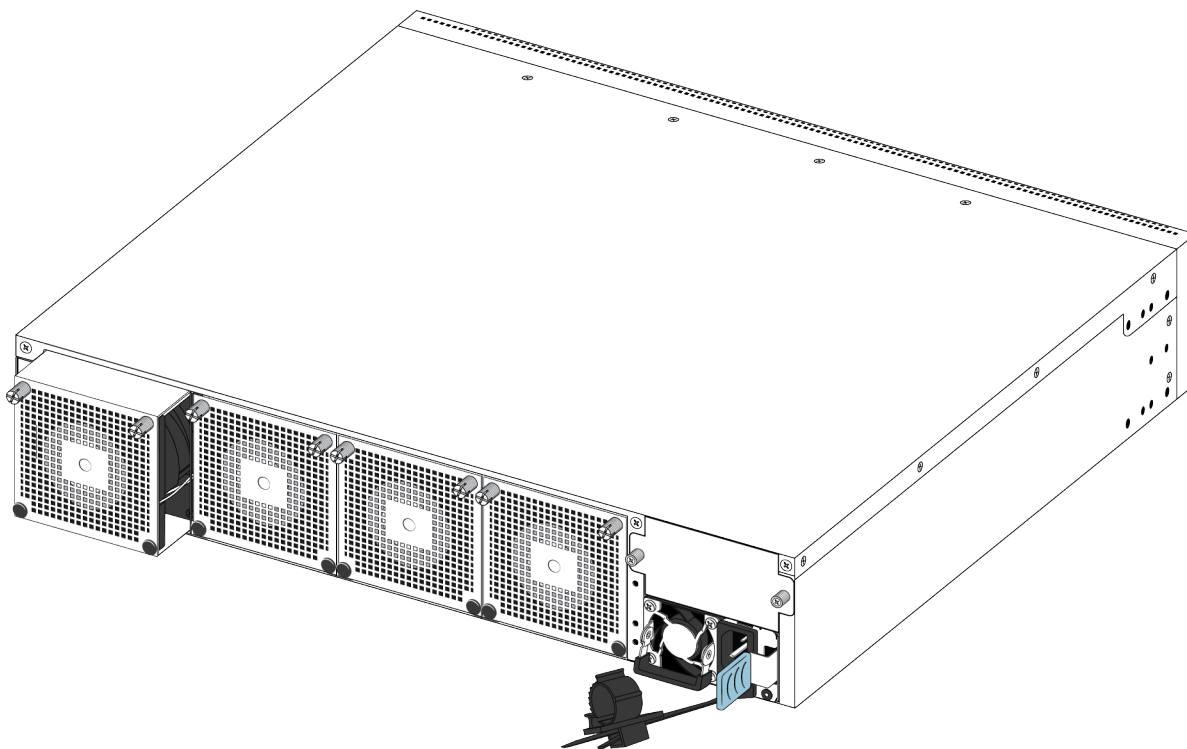
All four fans must be installed at all times to ensure proper ventilation. If a fan fails, replace it as soon as you can but leave it in place until you do. Leaving a fan bay unpopulated impairs the ability of the remaining fans to cool the chassis.

- 1 Check the Fan LED on the front of the chassis. Solid green indicates that all fan modules are operating normally. Blinking amber indicates that a fan module failed.
- 2 Enter the following command to determine which fan module failed.

```
show sys-info fan
```

This command shows the status of each fan module: up, down, or Not Present when a fan is removed.

- 3 Remove the fan module that failed by loosening the two thumb screws and pulling the fan module out of the chassis.





- 4 Insert the new fan module into the chassis.



#### Note

You can hot swap fan modules while the switch is operational.

- 5 Verify that the fan module is fully seated in the chassis and secure it with two thumb screws.
- 6 Enter the following command to check the temperature sensors inside the switch.

```
show sys-info temperature
```

## Example

Check the status of the fan modules.

```
VSP-8000:1>show sys-info fan
Fan Info :
Description OperStatus OperSpeed AirflowDir

Tray 1 Fan 1 up mediumSpeed front-back
Tray 2 Fan 1 up mediumSpeed front-back
Tray 3 Fan 1 up mediumSpeed front-back
Tray 4 Fan 1 up mediumSpeed front-back
```

Check the internal temperature of the switch.

```
VSP-8000:1>show sys-info temperature
Temperature Info :
CPU Temperature MAC Temperature PHY1 Temperature PHY2 Temperature
34 39 32 35
```

## LED state definitions

The figures and tables in the following sections describe the LEDs on the VSP 8000 Series switch. The tables describe LED operation for a switch that finishes the power-on self-test.



#### Warning

Fiber optic equipment can emit laser or infrared light that can injure your eyes. Never look into an optical fiber or connector port. Always assume that fiber-optic cables are connected to a light source.

## Switch LEDs

The following table describes the main switch LED state indications provided by LED color and fluctuation cues.

**Table 20: Switch LED state indicators**

| Label         | Color and Status | Description                                                                                                                            |
|---------------|------------------|----------------------------------------------------------------------------------------------------------------------------------------|
| <b>PWR</b>    | Off              | The switch is not receiving power and not operating.                                                                                   |
|               | Green (steady)   | The switch is receiving power from either one of the power supplies (if two power supplies are installed).                             |
|               | Green (blinking) | The system is in reset.                                                                                                                |
| <b>Status</b> | Off              | The switch is non-operational.                                                                                                         |
|               | Amber (steady)   | The switch encountered an error when running the diagnostic software.                                                                  |
|               | Amber (blinking) | The switch is booting and running diagnostic software. This is normal activity during the boot process.                                |
|               | Green (steady)   | The switch loaded the agent software code and is operating normally.                                                                   |
|               | Green (blinking) | The switch is loading the agent software code.                                                                                         |
| <b>RPS</b>    | Off              | A second power supply is not present in either PSU1 or PSU2.                                                                           |
|               | Amber (steady)   | The second power supply in PSU1 or PSU2 is removed.                                                                                    |
|               | Amber (blinking) | The second power supply, which was operating in PSU1 or PSU2, is either a fault condition or a PSU is present but not supplying power. |
|               | Green (steady)   | The second power supply (in either PSU1 or PSU2) is present and operating normally as a redundant power supply (RPS).                  |
|               | Green (blinking) | The second power supply (in either PSU1 or PSU2) is present, but the AC input has been disconnected.                                   |
| <b>Fan</b>    | Amber (steady)   | A fan module has been removed.                                                                                                         |
|               | Amber (blinking) | A fan module has failed.                                                                                                               |
|               | Green (steady)   | All fan modules are operating normally.                                                                                                |

## Management port LED state indicators

This section describes the management port LED state indicators by color and fluctuation cues. The management port uses two bi-colored LEDs to indicate the activity and speed of the link.

- The LED on the left side of the port (**Speed**) indicates the current speed of the port.
- The LED on the right side of the port (**Link/Act**) indicates the status of the link and whether or not it's active.

**Table 21: Management port LED state indicators**

| Label           | Color and Status | Description                        |
|-----------------|------------------|------------------------------------|
| <b>Speed</b>    | Off              | The port is operating at 10 Mbps.  |
|                 | Amber (steady)   | The port is operating at 100 Mbps. |
|                 | Green (steady)   | The port is operating at 1 Gbps.   |
| <b>Link/Act</b> | Off              | N/A                                |

**Table 21: Management port LED state indicators (continued)**

| Label | Color and Status | Description                    |
|-------|------------------|--------------------------------|
|       | Amber (steady)   | The port admin is disabled.    |
|       | Amber (blinking) | The port is not in use.        |
|       | Green (steady)   | The port has no data activity. |
|       | Green (blinking) | The port has data activity.    |

## SFP, SFP+, QSFP+, and QSFP28 port LED state indicators

This section describes the transceiver port LED state indicators by color and fluctuation cues.

### *SFP, SFP+ port LED state indicators*

These ports use the LED on the left side of the port (**Link/Act**) to indicate whether or not the link is established and if a transceiver is present and active.

**Table 22: SFP/SFP+ port LED state indicators**

| Label           | Color and Status      | Description                                                                            |
|-----------------|-----------------------|----------------------------------------------------------------------------------------|
| <b>Link/Act</b> | Off                   | There is no transceiver present and the port is administratively enabled.              |
|                 | Amber (blinking)      | The port received a remote fault indicator (RFI).                                      |
|                 | Amber (steady)        | The port is actively transmitting, but there is no link. This indicates a local fault. |
|                 | Green (steady)        | The port has established a link.                                                       |
|                 | Green (blinking)      | The port has established a link and there is data activity.                            |
|                 | Green (slow blinking) | The port is administratively disabled.                                                 |
| <b>In Use</b>   | Off                   | Link down                                                                              |
|                 | Green (blinking)      | Operating at 1Gbps link speed                                                          |
|                 | Green (Solid)         | Operating at 10Gbps link speed                                                         |

### *QSFP+, QSFP28 port LED state indicators*

The QSFP+/QSFP28 used in the system includes one bi-colored (amber/green) LED per port. The bi-colored LED is located in the transceiver cage. The bi-colored LED is labeled as “Link/Act”. The following table defines the operation of the QSFP+/QSFP28 LEDs:



#### Note

40Gbps Ethernet interfaces offer QSFP+ ports and 100Gbps Ethernet interfaces offer QSFP28 ports.

**Table 23: QSFP+/QSFP28 port LED state indicators**

| Label                                                                                            | Color and Status      | Description                                                                            |
|--------------------------------------------------------------------------------------------------|-----------------------|----------------------------------------------------------------------------------------|
| <b>Link/Act</b>                                                                                  | Off                   | There is no transceiver present and the port is administratively enabled.              |
|                                                                                                  | Amber (blinking)      | The port received a remote fault indicator (RFI).                                      |
|                                                                                                  | Amber (steady)        | The port is actively transmitting, but there is no link. This indicates a local fault. |
|                                                                                                  | Green (steady)        | The port has established a link.                                                       |
|                                                                                                  | Green (blinking)      | The port has established a link and there is data activity.                            |
|                                                                                                  | Green (slow blinking) | The port is administratively disabled or the transceiver has been removed.             |
| <b>Opt</b>                                                                                       | Off                   | Clear channel mode                                                                     |
| <b>Note:</b><br><b>Opt</b> applies only to the 8408QQ ESM. The 8402CQ ESM cannot be channelized. | Green (Solid)         | Channelized mode of operation                                                          |

## RJ45 port LED state indicators

This section describes the port LED state indicators by number, color and fluctuation cues.

### *100/1G/10G RJ45 port LED state indicators*

The RJ45 ports used in the system have single LED labelled as “Link/Activity”. The following table shows the status of the one LED:

**Table 24: 100/1G/10G RJ45 port LED state indicators**

| Label         | Color and Status      | Description                                          |
|---------------|-----------------------|------------------------------------------------------|
| Link/Activity | Off                   | The port does not have link.                         |
|               | Blue (solid)          | The port has link in 10Gbps mode.                    |
|               | Blue (blinking)       | The port has link and data activity in 10Gbps mode.  |
|               | Amber (solid)         | The port has link in 100Mbps mode.                   |
|               | Amber (blinking)      | The port has link and data activity in 100Mbps mode. |
|               | Green (solid)         | The port has link in 1Gbps mode.                     |
|               | Green (blinking)      | The port has link and data activity in 1Gbps mode.   |
|               | Green (slow blinking) | The port is administratively disabled.               |

*10/100/1000 RJ45 port LED state indicators*

The 10/100/1000 RJ45 ports used in the system have two LEDs. Each LED is located on either side of the RJ45 tab. The right LED is labeled as “Speed” and the left LED is labeled as “Link/Activity”. The following table shows the status of the two LEDs:

**Table 25: 10/100/1000 RJ45 port LED state indicators**

| Label         | Color and Status      | Description                                      |
|---------------|-----------------------|--------------------------------------------------|
| Speed         | Off                   | The port is operating at 10Mbps mode.            |
|               | Amber (solid)         | The port is operating at 100Mbps mode.           |
|               | Green (solid)         | The port is operating at 1Gbps.                  |
| Link/Activity | Green (solid)         | The port has link and there is no data activity. |
|               | Green (blinking)      | The port has link and there is data activity.    |
|               | Green (slow blinking) | The port is administratively disabled.           |

**Channelized LED state indicators**

The following table describes the channelization LED state indications provided by the color. These ports use **In Use Link/Act** to indicate whether or not the link is established.

**Table 26: Channelized LED state indicators**

| Label    | Color and Status                                                 | Description                                                                                                       |
|----------|------------------------------------------------------------------|-------------------------------------------------------------------------------------------------------------------|
| Opt      | Off                                                              | Clear channel (40GB) mode of operation                                                                            |
|          | Green (solid)                                                    | Channelized mode of operation                                                                                     |
| Link/Act | Off                                                              | All ports are link down, no faults                                                                                |
|          | Amber (blinking)                                                 | One or more ports have local fault                                                                                |
|          | Amber (steady)                                                   | One or more ports have remote fault                                                                               |
|          | Green (slow blinking)                                            | One or more ports are administratively down                                                                       |
|          |                                                                  | <b>Note:</b><br>Remote fault has priority over local fault<br>Local fault has priority over administratively down |
|          | Green (steady)                                                   | At least one port has link up, no activity, no faults                                                             |
|          | Green (blinking)                                                 | At least one port has link up and activity, no faults                                                             |
|          | <b>Note:</b><br>Administratively down has priority over link up. |                                                                                                                   |

## Enterprise Device Manager (EDM) representation of physical LED status

EDM displays the same LEDs that you see on the physical device.



### Note

LED blinking in EDM is representative of, but not identical to, the actual LED blinking rates on the switch.

For more information about the LEDs and a description of the blinking rates, see the preceding LED sections.

## 40GBASE-QSFP+ ports

When a port is channelized, use only break out cables (copper or active optical DAC) in it. Using other cables in either a channelized port or a non-channelized port results in mismatched link status between link partners, which can lead to network issues.

## MACsec operational notes

MACsec support varies based on the capabilities of the hardware, as noted below:

- For the VSP 8200 Series, MACsec is supported only on the 10G SFP+ ports. It is not supported on the 40G QSFP+ ports.
- For the VSP 8400 Series, MACsec is supported on the Ethernet Switch Modules (ESM) as noted below:
  - 8402CQ – Not supported.
  - 8408QQ – Supported on channelized interfaces only. Not supported on non-channelized ports.
  - 8418XSQ – Fully supported on the 10G SFP+ ports. On the 40G QSFP+ ports, supported on channelized interfaces only.
  - 8424XT – Not supported at 100 Mbps.
  - 8418XTQ – Supported only at 1G and 10G speeds on the 10G copper ports, not supported at 100M speeds. On the 40G QSFP+ ports, supported on channelized interfaces only.
  - 8424GT – Supported at 10M, 100M, and 1G speeds.
  - 8424GS – Supported at 100M and 1G speeds.
  - 8424XS – Fully supported.

## Viewing hardware information

Perform the following procedure to view system status and technical information about the VSP 8000 Series hardware components. You can view information about the switch (such as location), chassis (type, serial number, and base MAC address), temperature, power supplies, fans, cards, system errors, port locks, topology status, and message control information.

- 1 To enter User EXEC mode, log on to the switch.
- 2 View hardware information:

```
show sys-info [card | fan | led | power | temperature | uboot]
```

Viewing hardware information on VSP 8284XSQ switch:

```
VSP-8284XSQ:1>show sys-info
General Info :

SysDescr : VSP-8284XSQ (w.x.y.z)
SysName : VSP-8284XSQ
SysUpTime : 0 day(s), 00:06:04
SysContact : http://www.extremenetworks.com/contact/
SysLocation : 9 Northeastern Blvd,Salem,NH. 03079

Chassis Info:

Chassis : 8284XSQ
ModelName : 8284XSQ
BrandName : Extreme Networks.
Serial# : SDNIVSP8200B044
H/W Revision : 1
H/W Config :
Part Number : EC6200A01-E6
NumSlots : 2
NumPorts : 85
BaseMacAddr : b0:ad:aa:42:a0:00
MacAddrCapacity : 1024
MgmtMacAddr : b0:ad:aa:42:a0:81
System MTU : 1950

Card Info :

Slot# CardType Serial# Part# Oper Admin Power
 Status Status Status Status Status State
1 8242XSQ SDNIVSP8200B044 EC6200A01-E6 up up on
2 8242XSQ SDNIVSP8200B044 EC6200A01-E6 up up on

Temperature Info :

CPU Temperature MAC Temperature PHY1 Temperature PHY2 Temperature
34 39 32 35

Power Supply Info :

Ps#1 Status : empty
Ps#2 Status : UP
Ps#2 Type : AC
Ps#2 Description : DPS-800RB D
Ps#2 Serial Number: GWXD1349000123
Ps#2 Version : S0F
Ps#2 Part Number : 700508298

Total Power Available : 800 watts

Fan Info :

Description OperStatus OperSpeed AirflowDir
Tray 1 Fan 1 up mediumSpeed front-back
Tray 2 Fan 1 up mediumSpeed front-back
Tray 3 Fan 1 up mediumSpeed front-back
Tray 4 Fan 1 up mediumSpeed front-back

LED Info :

LED#1 Label : PWR
LED#1 Status : GreenSteady
```

```

LED#2 Label : Status
LED#2 Status : GreenSteady

LED#3 Label : Rps
LED#3 Status : Off

LED#4 Label : Fan
LED#4 Status : GreenSteady

System Error Info :

Send Login Success Trap : false
Send Authentication Trap : false
Error Code : 0
Error Severity : 0

Port Lock Info :

Status : off
LockedPorts :

Message Control Info :

Action : suppress-msg
Control-Interval : 5
Max-msg-num : 5
Status : disable

Configuration Operation Info Since Boot Up:
 Last Change: 0 day(s), 00:03:49
 Last Vlan Change: 0 day(s), 00:03:49
 Last Statistic Reset: 0 day(s), 00:00:00

Current Uboot Info :

VU-Boot 2012.04-00002-g6fb1c26 (Apr 26 2017 - 13:51:26) bld=17042617

```

## Variable definitions

Use data in the following table to use the `show sys-info` command.

| Variable           | Value                                                                                   |
|--------------------|-----------------------------------------------------------------------------------------|
| <i>card</i>        | Displays information about the device. Includes type, serial number, and assembly date. |
| <i>fan</i>         | Displays information about installed cooling ports.                                     |
| <i>led</i>         | Displays LED information in detail.                                                     |
| <i>power</i>       | Displays information about installed power supplies.                                    |
| <i>temperature</i> | Displays temperature information.                                                       |
| <i>uboot</i>       | Displays uboot details.                                                                 |



# 6 Translations of safety messages

---



## Caution

When you mount this device in a rack, do not stack units directly on top of one another. You must secure each unit to the rack with appropriate mounting brackets. Mounting brackets cannot support multiple units.

---



## Caution

### Achtung:

Wenn diese Einheit in einem Rack montiert wird, muß ein gewisser Abstand zur nächsten Einheit gelassen werden. Jede Einheit muß mit geeignetem Befestigungsmaterial gesichert werden. Das Befestigungsmaterial ist nicht für die gleichzeitige Befestigung mehrerer Einheiten geeignet.

---



## Caution

Si vous installez le module dans une baie, ne l'empilez pas directement sur un autre. Chaque module doit être fixé à sa propre baie à l'aide des supports de montage appropriés. Ces supports ne sont pas conçus pour résister à plusieurs modules.

---



## Caution

### Precaución:

Cuando monte este dispositivo en un bastidor, no apile las unidades directamente una encima de otra. Cada unidad debe fijarse en el bastidor con las abrazaderas de montaje adecuadas. Las abrazaderas de montaje no están diseñadas para sostener varias unidades.

---



## Caution

Se il dispositivo viene installato in un rack, non impilare le unità direttamente una sull'altra. Ogni unità deve essere fissata al rack con le staffe di montaggio appropriate. Le staffe di montaggio non sono state progettate per supportare più unità.

---

## Caution



**警告：**在机架中安装此设备时，请勿将多个部件叠放在机架中。必须用合适的安装托架将各个部件固定在机架中。安装托架无法支撑多个部件。



**注意：**この装置をラックに設置する場合は、ラック内のユニットを直接積み重ねないようにしてください。各ユニットは専用の取り付けブラケットでラックに固定する必要があります。取り付けブラケットは複数のユニットを支えるようには設計されていません。



**注意：**在機箱中掛載此裝置時，請不要直接在機箱中的另一個裝置上直接堆放裝置。每一裝置都必須使用適當的掛載托架以固定在機架中。掛載托架不能用來支撐多個裝置。



## Caution

If you are not installing a module in the slot, be sure to keep the metal cover plate in place over the slot. Removing the cover plate impedes airflow and proper cooling of the unit.



## Caution

## Achtung:

Wenn Sie kein Modul im Schacht verwenden, muß die Metallabdeckung über dem Schacht montiert sein. Eine Entfernung der Abdeckung führt zu einer Verschlechterung der Luftzirkulation und damit zu einer nicht ausreichenden Kühlung der Einheit.



## Caution

Si vous n'installez pas le module dans une baie, veillez à laisser la plaque métallique sur la baie. Si vous la retirez, l'aération du module ne peut pas s'effectuer correctement.



## Caution

## Precaution:

Si no instala ningún módulo en la ranura, asegúrese de mantener la placa de la cubierta de metal en la misma. Si la retira, impedirá que el aire circule y la unidad se refrigere adecuadamente.



## Caution

## Attenzione:

Se nello slot non vengono installati moduli, assicurarsi di mantenere la piastra di copertura metallica in sede sopra lo slot. La rimozione della piastra impedisce la ventilazione e il corretto raffreddamento dell'unità.

## Caution



**注意：**この装置をラックに設置する場合は、ラック内のユニットを直接積み重ねないようにしてください。各ユニットは専用の取り付けブラケットでラックに固定する必要があります。取り付けブラケットは複数のユニットを支えるようには設計されていません。



**注意：**スロットにモジュールを取り付けない場合は、スロットにある金属製のカバープレートが外れないように注意してください。カバープレートを動かすと airflow が妨げられ、適切なユニット冷却が行われなくなります。



**注意：**如果您未在插槽中安裝模組，請確定金屬殼板正確地蓋在插槽上。移除殼板會阻礙空氣流通以及裝置的適當冷卻度。



**警告：**如果您不打算在该插槽中安装任何模块，请务必使金属盖板正确地盖住该插槽。如果取下盖板，将妨碍通风及部件散热。



**警告：**この装置の電源は、電源コードを抜かない限り切断できません。緊急の場合にすばやく安全に切断できる場所に電源コードを接続してください。



**警告：**若要關閉此裝置的電源，拔掉插頭是唯一的方法。爲了因應緊急狀況，請將電源線連接到可以快速插拔的地方。

## Warning



Disconnecting the AC power cord is the only way to turn off AC power to this device. Allow at least 30 seconds for the this device to fully power down before restoring power. Otherwise, this device might produce a core file during the reset leading to an extra delay during boot time. Always connect the AC power cord in a quickly and safely accessible location in case of an emergency.

## Warning



## Warnung:

Das Gerät kann nur durch Ziehen des Netzsteckers ausgeschaltet werden. Schließen Sie das Netzkabel an einer Steckdose an, die in Notfällen schnell und sicher zugänglich ist.

## Warning



## Avertissement:

Pour mettre le module hors tension, vous devez impérativement déconnecter le cordon d'alimentation. En outre, vous devez dégager un espace minimal dans la zone de câblage pour pouvoir y accéder facilement en cas d'urgence.

**Warning**

**警告：** 断开交流电源线是切断本设备的交流电源的唯一方法。交流电源线一定要连接到在紧急时刻可以快速安全地接触到的位置。

**Warning****Advertencia:**

Para apagar el dispositivo debe desenchufar el cable. Conecte siempre el cable de alimentación a una toma segura y de fácil acceso por si se produjera alguna situación de emergencia.

**Warning****Avviso:**

L'unico modo per disattivare questo dispositivo consiste nello scollegare il cavo di alimentazione. Collegare sempre il cavo di alimentazione ad una presa che sia facilmente e rapidamente accessibile in caso di emergenza.

**Danger**

Use only power cords that have a grounding path. Without a proper ground, a person who touches the switch is in danger of receiving an electrical shock. Lack of a grounding path to the switch can result in excessive emissions.

**Danger****Vorsicht:**

Verwenden Sie nur Netzkabel mit Schutzerdung. Ohne ordnungsgemäße Schutzerdung besteht für Personen, die den Switch berühren, die Gefahr eines elektrischen Schlages. Eine nichtvorhandene Schutzerdung kann zu sehr starken Abstrahlungen führen.

**Danger**

N'utilisez que des cordons d'alimentation équipés de trajet de mise à la terre. Sans mise à la terre adaptée, vous risquez de recevoir une décharge électrique en touchant le commutateur. Par ailleurs, l'absence de trajet de mise à la terre peut générer des émissions excessives.

**Danger****Peligro:**

Utilice únicamente cables de alimentación con toma de tierra. De lo contrario, al tocar el interruptor puede recibir una descarga eléctrica. Si no hay un circuito de toma de tierra en el enchufe, puede producirse un exceso de emisiones.

---

**Danger****Pericolo:**

Utilizzare esclusivamente cavi di alimentazione dotati di un percorso per la messa a terra. Senza un'adeguata messa a terra, chiunque tocchi lo switch corre il rischio di ricevere una scossa elettrica. L'assenza di un percorso per la messa a terra verso lo switch può comportare un eccesso di emissioni.

---

**Danger**

**危険:** 接地経路を持つ電源コードを必ず使用するようになしてください。適切な接地がない状態でスイッチに触ると、感電する危険性があります。また、スイッチへの接地経路がないと、過度な放電を引き起こす可能性があります。



**危险:** 请仅使用接地的电源线。如果电源线不接地或接地不当，接触交换机的人员可能会受到电击。如果交换机不接地，则可能导致放电过量。

---

**Warning**

The lithium battery is not field replaceable. It should be removed and replaced by authorized personnel only. Contact Extreme Networks Technical Support for assistance if the battery requires replacement.

---