



# Virtual Services Platform 8000 Series Quick Install Guide

This poster provides information and instructions to install and commission a factory-supplied Extreme Networks Virtual Services Platform 8000 switch. You can download all documents referenced in this guide at <http://www.extremenetworks.com/support/documentation/>.

## 1 Before you start

Confirm that you have the following tools and cables:

- Phillips #2 screwdriver
- RJ-45 console port cable
- ESD cable

## 2 Unpack the equipment and verify package content

Note: Observe ESD precautions when unpacking.

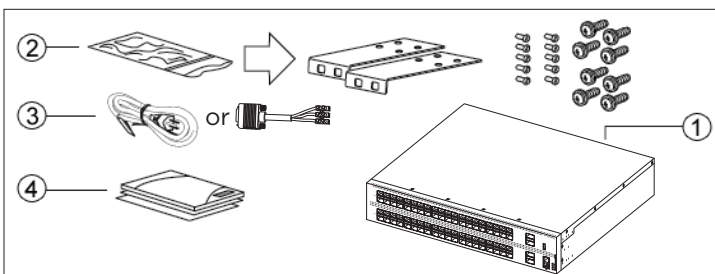

1. Extreme Networks Virtual Services Platform (VSP) 8000 Series switch
2. Rack-mounting hardware that includes:
  - a. Rack-mount brackets
  - b. Screws to attach brackets to the switch
  - c. Screws to attach the switch to the equipment rack
3. AC power cord or DC power supply wiring assembly (Note: A power cord is not included with the "A" variants of the switch.)
4. Documentation that includes this poster, regulatory information, how to locate software, and how to locate Release Notes.

## 3 Verify power supply unit (PSU) specifications

Optionally order a redundant PSU to provide redundancy and load sharing.

### VSP 8200 and VSP 8400 AC power specifications:

VSP 8000 models	Primary PSU	Redundant PSU (to be ordered if required)
VSP 8284XSQ-AC (ships with one AC PSU – order code: EC8200?01-E6)	800-W AC power supply (replacement order code: EC8005?01-E6)	800-W AC power supply (order code: EC8005?01-E6)  Note: The seventh character (?) of the switch order number must be replaced with the proper letter to indicate desired product nationalization.  • "A": No power cord included.  • "B": Includes European "Schuko" power cord common in Austria, Belgium, Finland, France, Germany, The Netherlands, Norway, and Sweden.  • "C": Includes power cord commonly used in the United Kingdom and Ireland.  • "D": Includes power cord commonly used in Japan.  • "E": Includes North American power cord.  • "F": Includes Australian power cord.
VSP 8284XSQ-AC No PC GSA (ships with one AC PSU but no power cord – order code: EC8200A01-E6GS)		
VSP 8284XSQ-AC NA PC GSA (ships with one AC PSU and a North American power cord – order code: EC8200E01-E6GS)		
VSP 8404 (ships with one AC PSU but no power cord – order code: EC8400A01-E6)		
VSP 8404 (for government systems) (ships with one AC PSU but no power cord – order code: EC8400A01-E6GS)		
VSP 8404C-AC (ships with one AC PSU – order code: EC8400?02-E6)		
VSP 8404C-AC NA PC GSA (ships with one AC PSU and a North American power cord – order code: EC8400E02-E6GS)		
VSP 8404C-AC No PC GSA (for government systems) (ships with one AC PSU but no power cord – order code: EC8400A02-E6GS)		

### VSP 8200 and VSP 8400 DC power specifications:

VSP 8000 models	Primary PSU	Redundant PSU (to be ordered if required)
VSP 8284XSQ-DC (ships with one DC PSU and a DC power supply wiring assembly – order code: EC8200001-E6)	800-W DC power supply (replacement order code: EC8005001-E6)	800-W DC power supply (replacement order code: EC8005001-E6)
VSP 8404-DC (ships with one DC PSU and a DC power supply wiring assembly – order code: EC8400001-E6)		
VSP 8404C-DC (ships with one DC PSU and a DC power supply wiring assembly – order code: EC8400002-E6)		

## 4 Install power supply unit

The VSP 8000 Series supports two field-replaceable 800-W power supplies. One power supply ships with the unit and you can optionally install a second power supply for redundancy. If you install a second power supply, the load is shared equally and neither one acts as a primary power supply.

Use this procedure to install either the primary or redundant power supply.

### Notes:

- Extreme Networks does not support installing a combination of AC-input and DC-input power supplies in the same chassis.
- There are two power supply slots (PSU1 on top and PSU2 on the bottom). If you only have one power supply, you can install it in either PSU1 or PSU2.
- The switch ships with filler panels covering the power supply slots. If you're not installing a second power supply, you must leave one of the filler panels in place for proper cooling.
- You can hot swap power supplies while the switch is operational. One power supply is required for continued switch operation.

1. Remove the two screws that secure the filler panel to the chassis. (Save the filler panel for possible future use.)
2. Insert the power supply into the slot.
3. Verify that the power supply is fully seated in the slot (AC PSU shown). The spring latch should engage and move back to its original position as shown below:

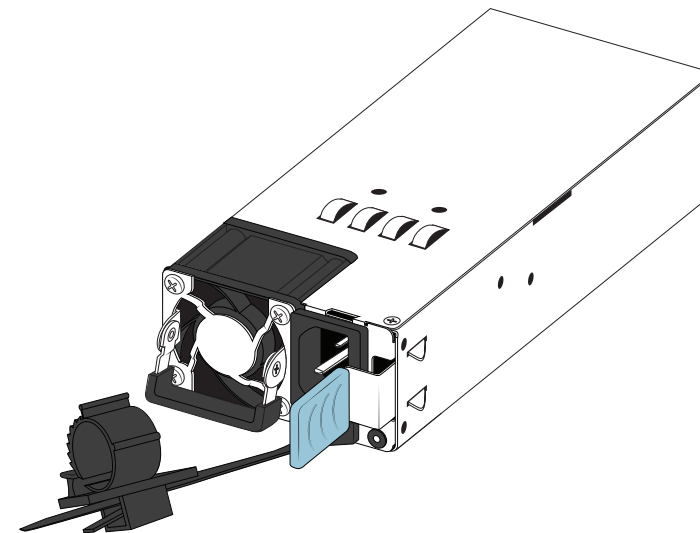

### Notes:

- The chassis design prevents an incorrect installation of a power supply. If you insert a power supply upside down, it will not fully insert.
  - The spring latch design ensures that you remove the power cord before removing a power supply from the chassis. If you don't remove the cord, you cannot move the latch to the left to release the hooks from the chassis.
4. After you install a power supply, proceed with connecting either the AC power cord or the DC power supply wiring assembly.
  5. Check the LED on the power supply. If it is off, the power supply is not operating. If it is green, the power supply is operating normally.

## 5 Mount the VSP 8000 switch

There are two ways to install a VSP 8000 switch in an equipment rack. Refer to one of the following sections:

- Mount the switch using the supplied bracket.
- Mount the switch using the optional slide rack mount kit.

Note: For more details on installing the VSP 8000 Series, see Installing the Extreme Networks VSP 8000 Series (NN47227-300).

### Prepare the rack

- Ensure that there is enough rack space to accommodate a 2RU switch (8.8 cm).
- The rack is bolted to the floor and braced if necessary.
- The rack is grounded to the same grounding electrode used by the power service in the area. The ground path must be permanent and must not exceed 1 Ohm of resistance from the rack to the grounding electrode.

### Mount the switch using the supplied bracket

Caution: Extreme Networks strongly recommends using the mounting brackets with a shelf. Using the brackets without a shelf can cause damage to the rack because of the chassis weight. When you mount the device in a rack, do not stack units directly on top of one another.

1. Disconnect the power cord from the switch.
2. Attach a bracket to each side of the switch as illustrated below.
  - Use the front set of holes for a 4-post rack installation.
  - Use the set of holes near the center of the chassis for a 2-post rack installation.

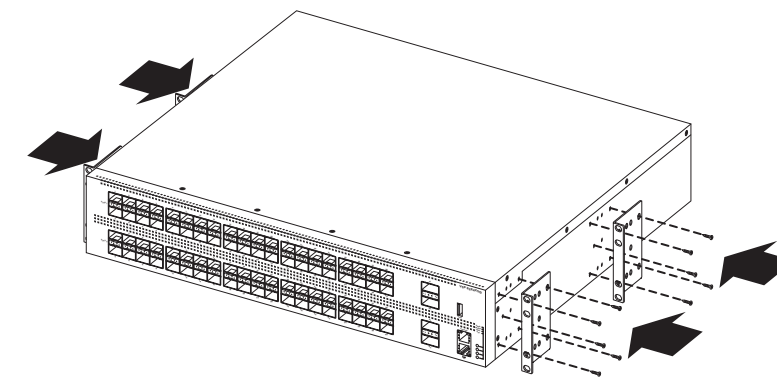

3. Slide the switch onto a shelf in the rack as illustrated.

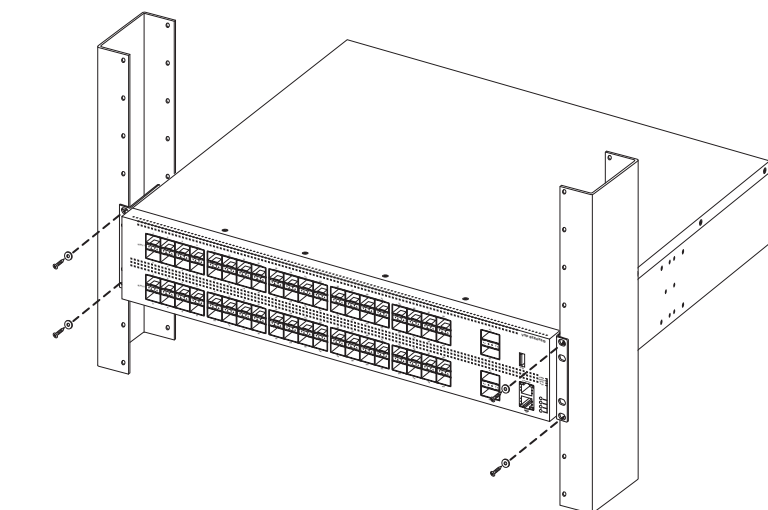

4. Insert and tighten the rack-mount screws.

## Mount the switch using the optional slide rack mount kit

Use the VSP 8000 Universal Slide Rack Mount Kit to install your switch in equipment racks with a depth from 300mm to 900mm. This kit is a separately ordered item (Part # EC8011002). For installation information, see the instructions that come with the kit. They are also in Installing the VSP 8000 Series (NN47227-300).

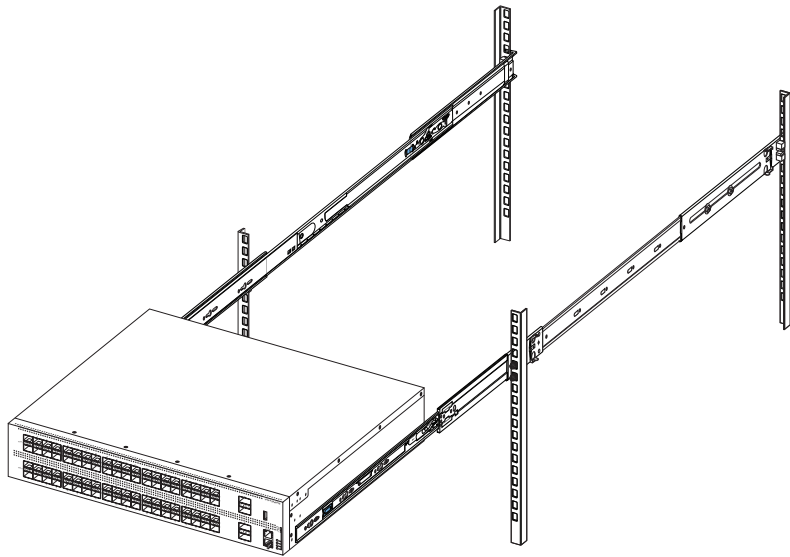

## 6 Power Up

Check the front-panel LED as the device powers on to be sure the PWR LED is green. If it's not, make sure the power cord is plugged in correctly. The switch will power on immediately when it is connected to a suitable power source.

## 7 Install SFP, SFP+, and QSFP+ transceivers

**Note:** Before installing, ensure the switch is up and running, and operating normally. Verify that the transceivers and network cabling support your network configuration. For a complete list of supported transceivers, see the Release Notes for your VSP 8000 model.

1. Remove the transceiver from the protective packaging.
2. Verify that the transceiver is the correct model for the network configuration.
3. Grasp the transceiver between your thumb and forefinger.
4. Insert the transceiver into the proper SFP/SFP+ slot on the switch as illustrated. Apply a light pressure to the transceiver until it clicks and locks into position in the slot.

## Commissioning the VSP 8000

### 1 Connect the console cable to the VSP 8000

#### Console port cabling specifications:

Ensure to use Category 5E or higher specification cabling for 1 Gbps/1000 Mbps operation. RJ-45 console port cables are as follows:

PEC Code	Name	Short Description
AL2011022-E6	RJ-45/DB-9 CONSOLE CABLE	The VSP 8000 has an RJ-45 female connector, so a serial cable with RJ-45 connectors, or a serial cable with a DB-9 female connector on one end and an RJ-45 on the other is appropriate. The maximum length for the console port cable is 25 feet (8.3 meters).
AL2011020-E6	RED DB-9 FEMALE TO RJ-45 ADAPTOR	Converts DB-9 MALE to RJ-45 serial port. The adaptor can be used for PC or device with DB-9 MALE console port. Also, can be used with Category 5 RJ-45 straight cable to provide console connection.
AL2011021-E6	BLUE DB-9 MALE TO RJ-45 ADAPTOR	Converts DB-9 FEMALE to RJ-45 serial port. This adaptor can be used to convert DB-9 of AL2011013-E6 console cable to RJ-45.

On your VSP 8000 switch, the console port (IOIO) is the RJ-45 port outlined with a blue border on the front of your switch (note orientation). Use an RJ-45 to DB-9 cable to connect the switch console port to your management terminal. Use adaptors to provide different connection options. The maximum length of a console cable is 25 feet (8.3 meters). The following tables describe the RJ-45 and DB-9 console port pin-out information. You can use the pin-out information to verify or create a console cable for use with your maintenance terminal.

#### DB-9 Console port pin assignments

Connector	Pin Number	Signal
	1	Carrier detect (not used)
	2	Transmit Data (TXD)
	3	Receive Data (RXD)
	4	Data terminal ready (not used)
	5	Signal ground (GND)
	6	Not used
	7	Request to send (not used)
	8	Not used
	9	Ring indicator (not used)

#### RJ-45 Console port pin assignments

Connector	Pin Number	Signal
	1	Ready to send (RTS) — optional
	2	Data terminal ready (DTR) — optional, can swap or link with pin 8
	3	Transmit data (TXD) — mandatory
	4	Carrier detect (DCD) — optional
	5	Ground (GND) — mandatory
	6	Receive data (RXD) — mandatory
	7	Data set ready (DSR) — optional
	8	Clear to send (CTS) — optional, can swap or link with pin 1.

1. Connect the console cable from the terminal to the console port (IOIO) of the switch to allow initial configuration. Any terminal or PC with the appropriate terminal emulator can be used as the management station.
2. Set the terminal protocol on the terminal or terminal emulation program to VT100 or VT100/ANSI.
3. Connect to the switch using the terminal or terminal emulation application.

#### Terminal emulation settings

Property	Value
Baud Rate	9600 bps
Data Bits	8
Stop Bits	1
Parity	None
Flow Control	None

## 2 Configure a management interface

Use one of the following steps to configure either an in-band or an out-of-band management interface.

### Step 2a: Configure an in-band management IP interface and VLAN

**Note:** The following procedure uses VLAN 20 and IP address 192.0.2.24 as an example.

1. Create a VLAN:  
Switch:1(config)# vlan create 20 type port-mstprstp 0
2. Add VLAN members:  
Switch:1(config)# vlan members add 20 1/1-1/4
3. Activate ports:  
Switch:1(config)# interface gigabitEthernet1/1-1/4  
Switch:1(config-if)# no shutdown
4. Configure an IP interface for the VLAN:  
Switch:1(config)# interface vlan 20  
Switch:1(config)# ip address 192.0.2.24 255.255.255.0
5. Add a static route:  
Switch:1(config)# ip route 192.0.2.0 255.255.255.0 192.0.2.1 weight 1

### Step 2b: Configure an out-of-band management IP interface and VLAN

1. Configure the management interface:  
Switch:1(config)# interface mgmtEthernet mgmt  
Switch:1(config-if)# ip address 192.0.2.24/24
2. Configure static routes:  
Switch:1(config)# router vrf mgmtrouter  
Switch:1(config-vrf)# ip route 192.0.2.0 255.255.255.0 192.0.2.1 weight 1

## Shutting down the VSP 8000

**Caution:** Before you unplug the power cord, always perform the following shutdown procedure. This procedure flushes any pending data to ensure data integrity.

1. Enter the Privileged EXEC command mode:  
enable
2. Shutdown the VSP 8000.  
sys shutdown
3. Before you unplug the power cord, wait until you see the following message:  
System Halted, OK to turn off power.

For more information on this and other administration procedures, see Administering VSP Operating System Software (NN47227-600).

## Recommended reading

To obtain additional documentation references, go to <http://www.extremenetworks.com/support/documentation/> and download the following:

- Regulatory Reference (NN47227-105)
- Locating Software and Release Notes (NN47227-106)
- Documentation Reference (NN47227-100)
- Installing the VSP 8000 Series (NN47227-300)
- Quick Start Configuration (NN47227-102)
- Release Notes (NN47227-401)



6480 Via Del Oro  
San Jose, CA 95119  
Tel: +1 408-579-2800  
Toll-free: +1 888-257-3000  
**WWW.EXTREMENETWORKS.COM**