

ExtremeSwitching™

Installation Job Aid for Virtual Services Platform 8200

Release 6.1.0.0
NN47227-304
Issue 02.01
November 2017

Safety messages

Caution:

To protect the switch against ESD damage, take the following measures before you connect data cables to the device:

- Always use antistatic wrist straps. Make sure you adjust the strap to provide good skin contact.
- Ensure that you properly ground work surfaces and equipment racks for protection against electrostatic discharge. You must connect the common point to the building ground wire. In a properly wired building, the nearest reliable ground is typically at the electrical outlet.
- Avoid contact between equipment and clothing. The wrist or ankle strap protects only the equipment from ESD voltages on the body; ESD voltages on clothing can still cause damage.
- Avoid touching any connector pins.
- Do not remove the wrist or ankle strap until the installation is complete.

Caution:

When you mount this device in a rack, do not stack units directly on top of one another. You must secure each unit to the rack with appropriate mounting brackets. Mounting brackets cannot support multiple units.

Caution:

If you are not installing a redundant power supply in the slot, be sure to keep the metal cover plate in place over the slot. Removing the cover plate impedes airflow and proper cooling of the unit.

⚠ Warning:

Disconnecting the power cord is the only way to turn off power to this device. Allow at least 30 seconds for the device to fully power down before restoring power. Otherwise, this device might produce a core file during the reset leading to an extra delay during boot time.

⚠ Danger:

Use only power cords that have a grounding path. Without a proper ground, a person who touches the switch is in danger of receiving an electrical shock. Lack of a grounding path to the switch can result in excessive emissions.

⚠ Warning:

The lithium battery is not field replaceable. It should be removed and replaced by authorized personnel only. Contact Extreme Networks Technical Support for assistance if the battery requires replacement.

⚠ Warning:

Fiber optic equipment can emit laser or infrared light that can injure your eyes. Never look into an optical fiber or connector port. Always assume that fiber-optic cables are connected to a light source.

Technical specifications

The following table provides the technical specifications for the individual switches in this series. Ensure that the area where you install the switch and where it operates meets these requirements.

⚠ Warning:

To avoid bodily injury from hazardous electrical shock and current, never remove the top of the device. No user-serviceable components are inside.

Table 1: Physical specifications

Height	3.5 in. (88.9 mm) - 2U
Width	17.5 in. (444.5 mm) - 19" rack mountable
Depth	19.68 in. (500 mm)
Weight of VSP 8284XSQ (EC8200x01-E6)	32.1 lb (14.56 kg)
Weight of spare AC power supply unit (EC8005x01-E6)	1.9 lb (0.862 kg)
Weight of spare DC power supply unit (EC8005001-E6)	1.76 lb (0.8 kg)

Table 2: Electrical specifications

Power consumption	565.34 W with no transceivers, 765.34 W with transceivers
Thermal rating	1929.02 BTU/hr with no transceivers, 2611.448 BTU/hr with transceivers
MTBF rating	137,000 hours (15.6 years)

Table 3: Environmental specifications

Operating Temperature	0°C to 50°C (32°F to 122°F)
Storage Temperature	-40°C to 85°C (-40°F to 185°F)
Operating Humidity	0 to 95 percent noncondensing
Storage Humidity	0 to 95 percent noncondensing
Maximum Operating Altitude	3,048m (10 000 feet) above sea level
Storage Altitude	0 to 12,192m (0 to 40,000ft) above sea level
Acoustic Noise	Less than or equal to 35 db at 21°C and less than or equal to 43 db at 50°C. The temperature is allowed to have ±3.5°C deviation around the threshold of 35C, (measurement methods based on ISO 7779).
Miscellaneous Operating Considerations	<ul style="list-style-type: none"> • No heat sources such as hot air vents or direct sunlight near the switch. • No sources of severe electromagnetic interference near the switch. • No excessive dust in the environment. • An adequate power source is within 6 feet (1.83 meters) of the switch. One 15-amp circuit is required for each power supply. • At least 2 inches (5.08 centimeters) of clearance on the front and back of the switch for ventilation. • Cables should be dressed to prevent blocking air flow.

Installing a power supply

The VSP 8284XSQ ships with a power supply, but it is not installed in the chassis. Refer to the following procedures to install either an AC or a DC power supply.

There are two power supply slots (PSU1 on top and PSU2 on the bottom).

- If you only have one power supply, you can install it in either PSU1 or PSU2.
- If you install a second power supply, neither one acts as a primary power supply. The two power supplies load share equally.

Important:

Installing a combination of AC-input and DC-input power supplies in the same chassis is not supported.

To install an AC power supply, see [Installing an AC power supply](#) on page 4.

To install a DC power supply, see [Installing a DC power supply](#) on page 7.

Installing an AC power supply

The VSP 8284XSQ supports two field-replaceable 800 W power supplies. One comes with the switch and you can install a second power supply to provide redundancy and load sharing.

Before you begin

- Remove the power cord before installing or removing the power supply.

*** Note:**

The design of the latch mechanism that secures the power supply enforces this safety practice.

Procedure

1. Remove the two screws that secure the filler panel to the chassis. (Save the filler panel for possible future use.)

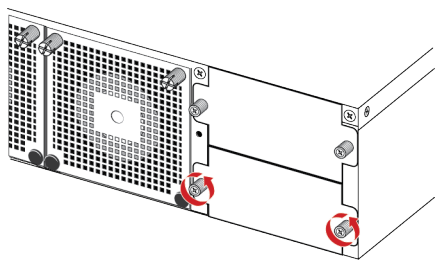

2. Slide the power supply into the slot.

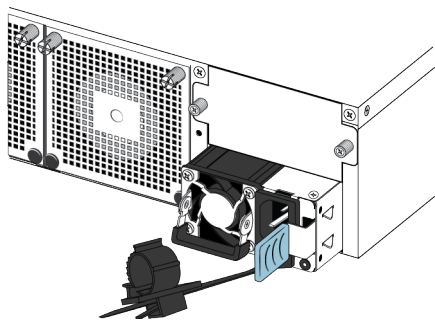

3. Verify that the power supply is fully seated in the slot. The spring latch should engage and return to its original position.

*** Note:**

The chassis design prevents an incorrect installation of a power supply. If you insert a power supply upside down, it will not fully insert.

4. Once you install a power supply, you can connect the AC power cord to the power supply on the back of the switch, and then connect the cord to an AC power outlet.

! Important:

The VSP 8200 does not have an AC power switch. When you connect the power cord to a power supply and connect the cord to an AC power outlet, the switch powers up immediately.

! Warning:

Disconnecting the AC power cord is the only way to turn off AC power to the VSP 8200. Allow at least 30 seconds for the VSP 8200 to fully power down before restoring power. Otherwise, the VSP 8200 might produce a core file during the reset leading to an extra delay during boot time. Always connect the AC power cord in a location that is quickly and safely accessible in case of an emergency.

5. Check the LED on the bottom right side of the power supply. Solid green indicates that power is operating normally. If it's off, check the connections.

! Important:

You can hot swap power supplies while the switch is operational. One power supply is required for continued switch operation.

AC power supply specifications

The VSP 8284XSQ comes with an 800 W AC power supply and you can install a secondary power supply for redundancy.

! Important:

You must have either a power supply or a power supply cover in each bay to ensure proper ventilation. Leaving a power supply bay unpopulated or uncovered impairs the ability of the fans to cool the chassis.

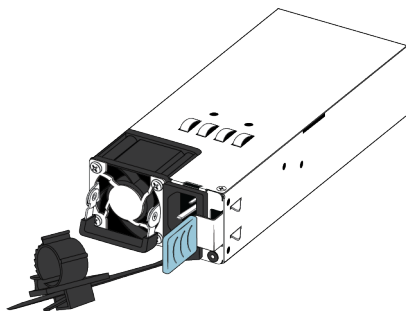

Figure 1: AC power supply

The 800 W AC power supply uses an IEC 60320 C16 AC power cord connector. The AC power cord is in close proximity to the hot air exhaust, and supports high operating temperatures.

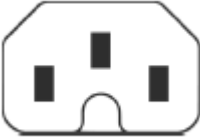

Figure 2: IEC 60320 C16 connector

The following table describes the regulatory AC power specifications for the VSP 8284XSQ switch. Note that regulatory power specifications are based on the maximum rated capacity of the power supplies and are not based on typical power consumption, which is typically lower.

Table 4: AC power specifications

	8284XSQ-AC
Input Current:	15A/7.5A
Input Voltage (rms):	100 to 240 VAC at 50 to 60 Hz
Power Consumption:	800 W maximum
Thermal Rating:	2730 BTU/Hr maximum
Inrush Current:	40 A maximum
Turn on Condition:	1 second maximum after application of AC power
! Important: 12 V output rise time, from 10 to 90 percent, must be the maximum of 50 ms and monotonic under all defined input and output conditions.	
Efficiency:	70 percent minimum

AC power cord specifications

To connect AC power to the switch, you need an appropriate AC power cord as described in the following table, also see the following table for plug specifications.

Table 5: International power cord specifications





Country and Plug Specification	Specifications	Typical Plug
Continental Europe: <ul style="list-style-type: none"> • CEE7 standard VII male plug • Harmonized cord (HAR marking on the outside of the cord jacket to comply with the CENELEC Harmonized Document HD-21) 	<ul style="list-style-type: none"> • 220 or 230VAC • 50 Hz • Single phase 	 <small>3280A</small>
United States of America, Canada, and Japan: <ul style="list-style-type: none"> • NEMA5-15P male plug • UL-recognized (UL stamped on cord jacket) 	<ul style="list-style-type: none"> • 100 or 120VAC • 50–60 Hz • Single phase 	 <small>3271A</small>

Table continues...

Country and Plug Specification	Specifications	Typical Plug
<ul style="list-style-type: none"> • CSA-certified (CSA label secured to the cord) 		
United Kingdom: <ul style="list-style-type: none"> • BS1363 male plug with fuse • Harmonized cord 	<ul style="list-style-type: none"> • 240VAC • 50 Hz • Single phase 	
Australia: <ul style="list-style-type: none"> • AS3112-1981 male plug 	<ul style="list-style-type: none"> • 240VAC • 50 Hz • Single phase 	

⚠ Danger:

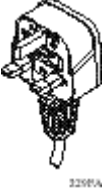
Using power cords with a proper grounding path

Use only power cords that have a grounding path. Without a proper ground, a person who touches the switch is in danger of receiving an electrical shock. Lack of a grounding path to the switch can result in excessive emissions.

Installing a DC power supply

! Important:

Installing a combination of AC-input and DC-input power supplies in the same chassis is not supported.

The VSP 8284XSQ supports two field-replaceable 800 W power supplies. One comes with the switch and you can install a second power supply to provide redundancy and load sharing.

There are two power supply slots (PSU1 on top and PSU2 on the bottom).

- If you only have one power supply, you can install it in either PSU1 or PSU2.
- If you install a second power supply, neither one acts as a primary power supply. The two power supplies load share equally.

Before you begin

- Remove the DC power supply wiring assembly before installing or removing the power supply.

*** Note:**

The design of the latch mechanism that secures the power supply enforces this safety practice.

Procedure

1. Remove the two screws that secure the filler panel to the chassis. (Save the filler panel for possible future use.)

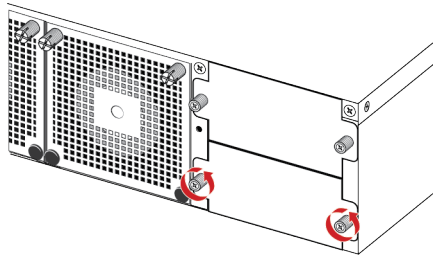

2. Slide the power supply into the slot.

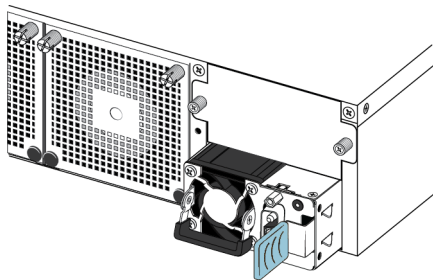

3. Verify that the power supply is fully seated in the slot. The spring latch should engage and return to its original position.

*** Note:**

The chassis design prevents an incorrect installation of a power supply. If you insert a power supply upside down, it will not fully insert.

! Important:

The VSP 8200 does not have a power switch. When you connect the DC power source to the DC power supply wiring assembly and then plug the assembly into the DC power supply, the switch powers up immediately.

⚠ Warning:

Disconnecting the DC power supply wiring assembly from the power supply is the only way to turn off DC power to the VSP 8200. Allow at least 30 seconds for the VSP 8200 to fully power down before restoring power. Otherwise, the VSP 8200 might produce a core file during the reset leading to an extra delay during boot time.

4. Once you install a power supply, use the following steps to connect the DC power supply wiring assembly:

- a. Extreme Networks supplies a DC power supply wiring assembly to connect the DC power supply to the DC input power source.

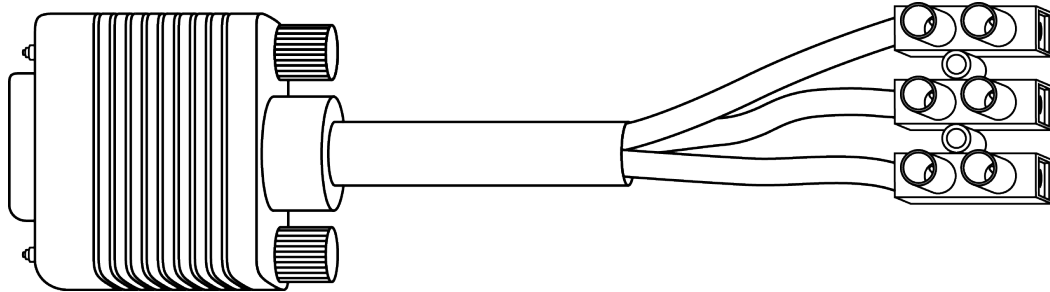

- b. Strip 0.8 in. (2 cm) of insulation from the ends of the power source cables.
- c. Refer to the tag attached to the DC power supply wiring assembly to insert the cables into their appropriate connectors.

⚠ Voltage:

Ensure that the positive and negative power inputs are connected to the correct connectors and that the switch is properly grounded before connecting it to a power source.

- d. Use a screwdriver to crimp the cables to the DC power supply wiring assembly.

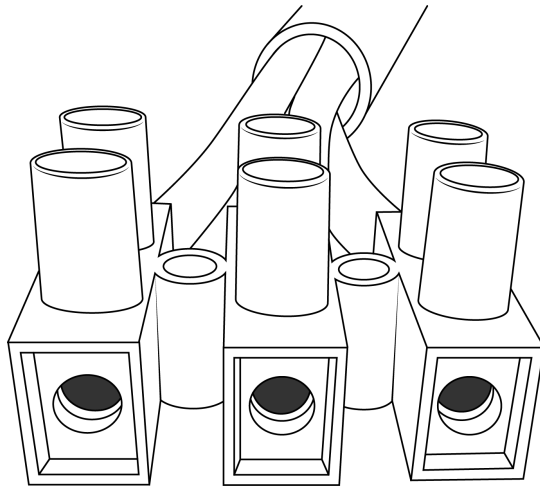

- e. Use a screwdriver to terminate the three raw wires to a DC power source.
 - f. Connect the DC power supply wiring assembly to the DC power supply and screw it in to secure the connection.
5. Check the LED on the top right side of the power supply. If it is off, the power supply is not operating. If it is green, the power supply is operating normally. The following table describes all the LED states.

Table 6: DC power supply LED states

Color and Status	Description
Off	There is no DC power to either power supply.
Green (steady)	There is output and the power supply is operating normally.
Green (blinking)	The power supply is present, but its output is standby voltage (12VSB).
Amber (steady)	SHUTDOWN: The power supply is not supplying power to the switch because the power cord is unplugged or the power supply shutdown for faults such as a fan failure or exceeding limits for Over Current Protection (OCP) or Over Voltage Protection (OVP).
Amber (blinking)	WARNING: The power supply continues to operate, but there are one or more warning events such as high temp, high power, high current, or a slow fan.

! Important:

You can hot swap power supplies while the switch is operational. One power supply is required for continued switch operation.

DC power supply specifications

The VSP 8284XSQ-DC comes with one 800 W DC power supply and you can install a secondary power supply for redundancy.

! Important:

You must have either a power supply or a power supply cover in each bay to ensure proper ventilation. Leaving a power supply bay unpopulated or uncovered impairs the ability of the fans to cool the chassis.

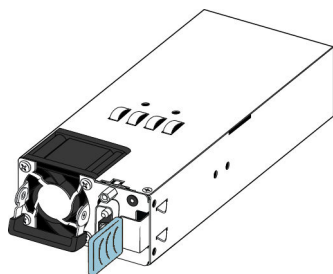

Figure 3: DC power supply

The 800 W DC power supply uses a DC power supply wiring assembly to connect the power supply to the DC power source.

The following table describes the regulatory DC power specifications for the VSP 8284XSQ-DC switch. Note that regulatory power specifications are based on the maximum rated capacity of the power supplies and are not based on typical power consumption, which is typically lower.

Table 7: DC power specifications

	8284XSQ-DC
Input Current:	40.5V/24A to 60V/16A
Input Voltage (rms):	40.5 to 60 VDC
Power Consumption:	800 W maximum
Temperature:	Operating range: 0 to 50 °C Non-operating range: -40 to 70 °C
Inrush Current:	50 A maximum
Turn on Condition:	500 milliseconds maximum after application of DC power
<p>! Important:</p> <p>12 V output rise time, from 10 to 90 percent, must be the maximum of 70 ms and monotonic under all defined input and output conditions.</p>	
Efficiency:	<ul style="list-style-type: none"> • 88% minimum at 100% load level • 92% minimum at 50% load level • 88% minimum at 20% load level • 80% minimum at 10% load level

Installing the switch in an equipment rack

This procedure describes how to install the switch using the supplied brackets on a two-post or four-post equipment rack. The brackets secure the chassis and prevent it from sliding around during vibration or when inserting or extracting transceivers.

- If you have a two-post rack, install the brackets in the mid-chassis position.
- If you have a four-post rack, install the brackets in the front chassis position. In the front position, the switch should rest on a customer-supplied tray or shelf.

⚠ Caution:

Do not mount the chassis with brackets in the front position without using a tray under the chassis. The chassis weight will cause damage to a rack when mounted by the front panel, especially in an environment with vibration or in an earthquake prone area.

Procedure

1. Disconnect the power cord from the switch.

2. Attach a bracket to each side of the switch using a #2 Phillips screwdriver as illustrated below.

⚠ Caution:

The following figure shows the bracket position for a 4-post rack installation. If you are installing the chassis in a 2-post rack, attach the bracket in the location recessed 150 mm from the front of the chassis.

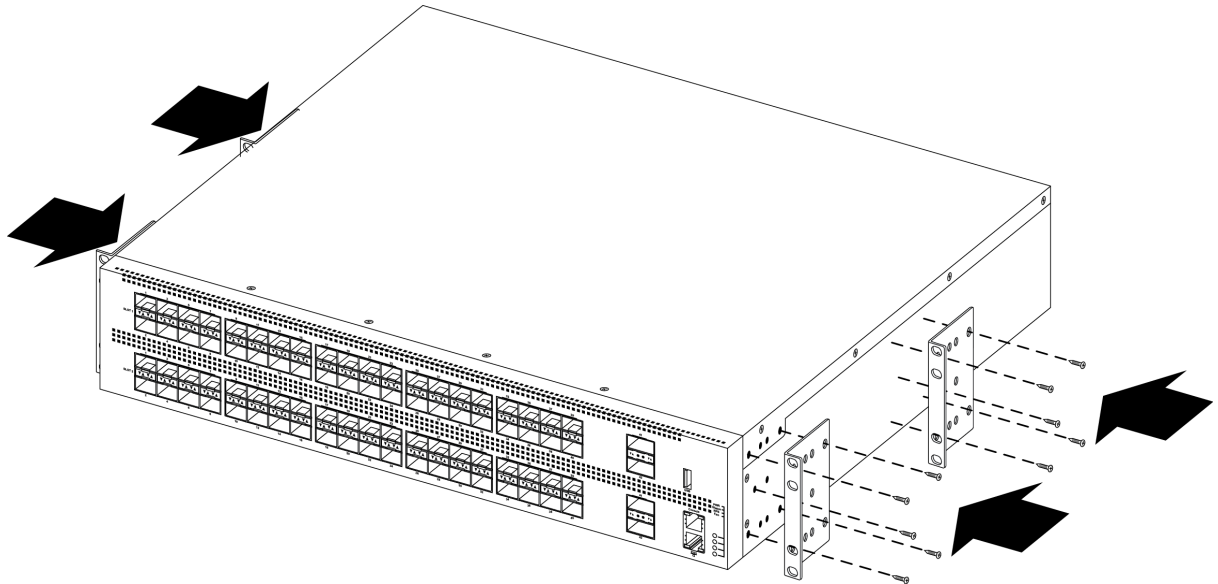

3. Slide the switch onto a shelf or tray in the rack.

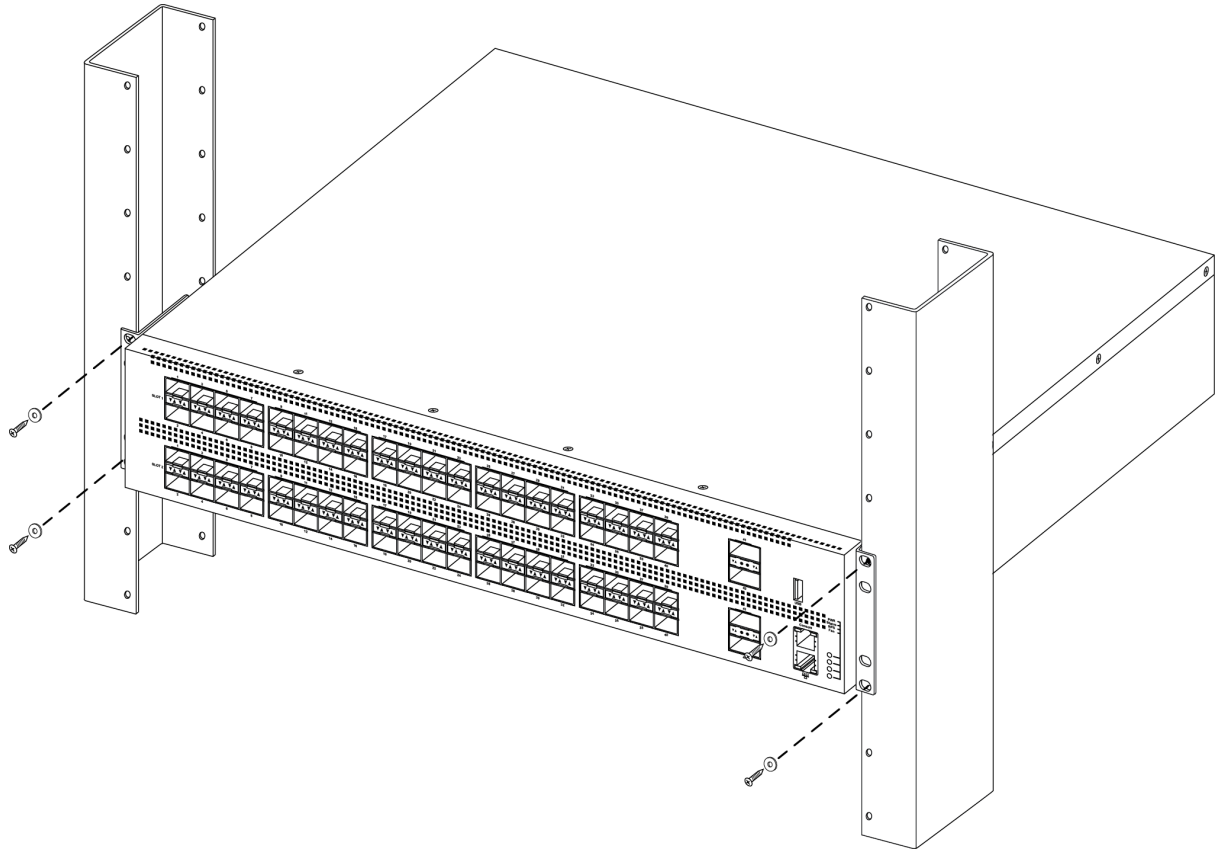

4. Insert and tighten the rack-mount screws.
5. Verify that the switch is securely fastened to the rack.
6. Connect power and network connections to the switch.