

Introduction

For Extreme Networks industrial switches, the POE INJ-75W-24 is a single-port passive PoE injector that provides maximum 75W power over CAT5 or 5e UTP/STP Ethernet cable by four pairs. The POE INJ-30W-24 is a single-port PoE injector that complies with IEEE802.3af/at and provides maximum 30W power over CAT5 or 5e UTP/STP Ethernet cable by two pairs.

The injectors support two redundant DC inputs from 20 VDC – 60 VDC for industrial backup. You can connect the PoE injectors to Ethernet-powered devices, such as wireless APs, pan-tilt-zoom (PTZ) speed dome cameras, IP videophones, and other high-power Ethernet end terminals. These terminals must allow the PoE injector to deliver both data and power over an Ethernet cable in an industrial environment.

Cautions & Warnings

Warning: The metal surface can be very hot when operating in high temperature. To avoid injury, do not touch the metal surface.

Warning: Do not open or disassemble this equipment. It can only be repaired and maintained by qualified personnel. Failure to follow these instructions will result in death, serious injury, or equipment damage.

Warning: Use only qualified cables that can be used under specified operation temperature to avoid any danger.

Caution: The device shall be supplied by LPS (Limited Power Source) provided with double insulation (SELV), certified by UL/IEC 60950, UL61010 or UL61010-2-201 listed certified, and a working temperature of 75°C (167°F) or better.

Caution: Use only dry cloths to clean this equipment.

Caution: This product is intended to be mounted to a well-grounded mounting surface, such as a metal panel.

Derating Curve

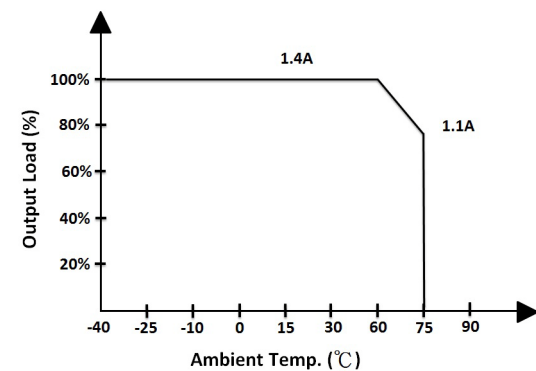

O/P Current (A)	Operating Temperature (°C/°F)
1.1	60-75 / 140-167
1.4	Below 60 / 140

Warning: This surface of this device becomes hot to the touch above 60°C (140°F) ambient temperature. The device must be installed in a Restricted Access Location where access is permitted to service personnel only and must be secured through the use of a special tool or lock and key.

PoE Injector Features

POE INJ-75W-24

- 54V, 75 watts of high Power-over-Ethernet
- Support 10/100/1000 Mbps for PoE OUT and DATAIN
- Two DC inputs for power redundancy with range from 20 VDC – 60 VDC
- Industrial rated IP30
- -40 to 75°C operating temperature range
- DIN-rail and wall mount

POE INJ-30W-24

- IEEE802.3af/at compliant
- 54V, 30 Watts of High Power-over-Ethernet
- Support 10/100/1000Mbps for PoE OUT and DATAIN
- Two DC inputs for power redundancy with range from 20 VDC – 60 VDC
- Industrial rated IP30
- -40 to 75°C operating temperature range
- DIN-rail and wall mount

Panel Layout

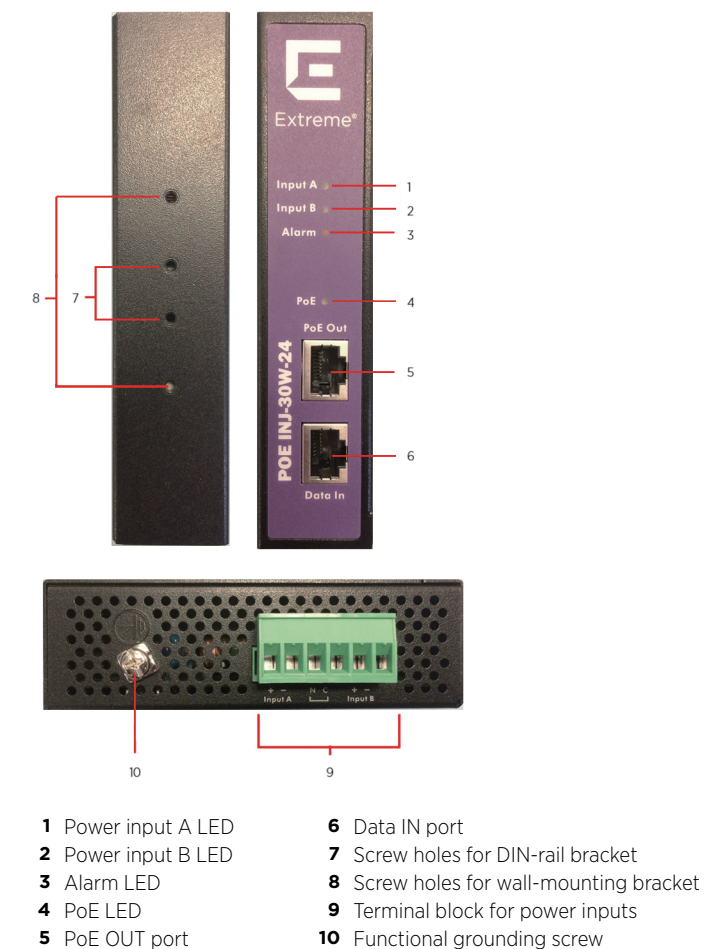

Note 1: The 75W model shares the same layout as the 30W model.

Note 2: Functional ground \perp : Earthing of a point in equipment or in a system, which is necessary for a purpose other than safety.

Figure 1 Terminal Block & Wiring Screw Torque Closeup

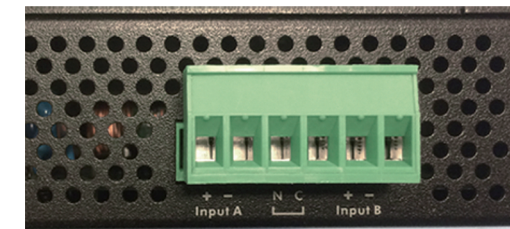

The standard screw torque for the terminal block is 3.5 kgf/cm.

Note: Wires used on the equipment must be at least 105°C and 14 AWG or better.

LED Indicators

Table 1 POE INJ-75W-24

Indication	Color	Description	Behavior
Input A	Green	Source power 1 is connected.	On/Off
Input B	Green	Source power 2 is connected.	On/Off
Alarm	Red	One source power is Fault.	On/Off
PoE	Green	PoE power is on.	On/Off

Table 2 POE INJ-30W-24

Indication	Color	Description	Behavior
Input A	Green	Source power 1 is connected.	On/Off
Input B	Green	Source power 2 is connected.	On/Off
Alarm	Red	One source power is Fault.	On/Off
PoE	Green	IEEE802.3 PDF is connected.	On/Off

Installation Instructions

This box includes both wall-mount and DIN-rail hardware brackets. When installing the DIN-rail bracket, be sure to correctly align the orientation pin.

Figure 2 Wall-mount Bracket Assembly

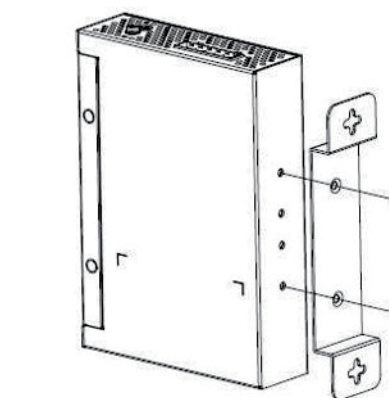
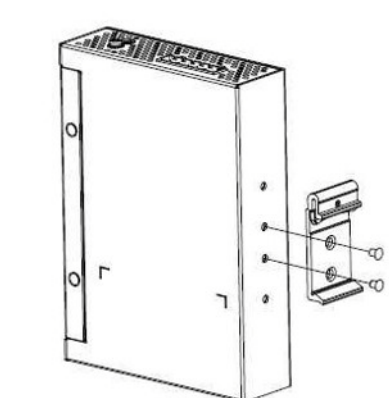

Figure 3 DIN-rail Bracket Assembly



The DIN-rail bracket has a metal spring in the upper rail of the bracket. This spring is compressed for mounting and un-mounting by applying downward force.

To install this equipment on DIN-rail, you need approximately 12-15 kgf-cm. To remove from DIN-rail, simply reverse the steps below.

Figure 4 DIN-rail Mounting

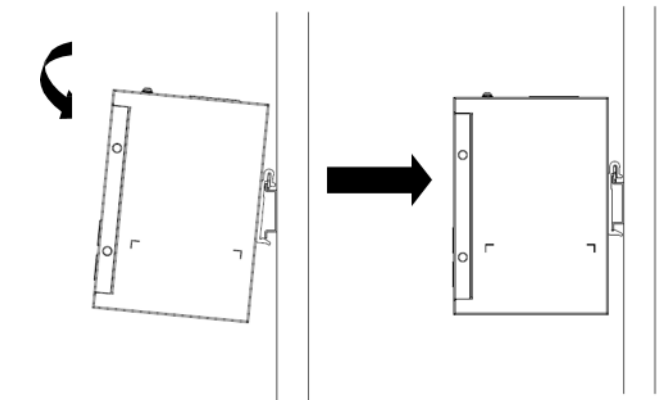

Device Setup

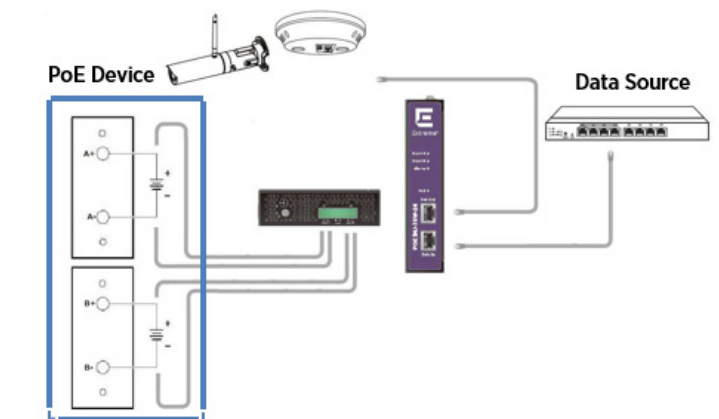

Specifications

	POE INJ-75W-24	POE INJ-30W-24
OUTPUT		
DC Voltage	54V	54V
Rated Current	1.4A	0.6A
Operation Current	0-1.4A	0-0.6A
Rated Power	75W	30W max.
Ripple & Noise	100 mV (Note 3)	100 mV (Note 3)
4-Pair Powering	1/2 (-), 3/6 (+) Spare Pairs 4/5 (+), 7/8 (-)	4/5 (+), 7/8 (-)
Gigabit LAN Port	Yes	Yes
LAN transformer	Yes	Yes
IEEE 802.3af/at Compliant	No	Yes
Output Voltage Tolerance	±5%	±5%
Line Regulation	±1%	±1%
Load Regulation	±3%	±3%

	POE INJ-75W-24	POE INJ-30W-24
Turn-on Time and Rise Time	<1s, 100 ms at 24 VDC / 54 VDC at full load	<1s, 100ms at 24 VDC / 54 VDC at full load
INPUT A & B		
Maximum Voltage	20 VDC-60 VDC	20 VDC-60 VDC
Efficiency (Typ.)	85% at 24 VDC / 54 VDC at full load	80% at 24 VDC / 54 VDC at full load
DC Current (Full Load)	4A / 24 VDC	2A / 24 VDC
PROTECTION		
Short, OPP	Protection type: Auto-Recovery	Protection type: Auto-Recovery
Over Voltage	<60 V at 24 VDC/ 54 VDC at full load	<60 V at 24 VDC/ 54 VDC at full load
Over Temperature	90°C ±5° Protection type: Auto-Recovery	90°C ±5° Protection type: Auto-Recovery
ENVIRONMENT		
Operation Temp.	-40 - 75°C	-40 - 75°C
Working Humidity	5 - 90% RH non-condensing	5 - 90% RH non-condensing
Storage Temp., Humidity	-40 - 85°C 5 - 95% RH	-40 - 85°C 5 - 95% RH
Temp. Coefficient	±0.03%/°C (0 - 50°C)	±0.03%/°C (0 - 50°C)
HI-POTS		
Dielectric Withstand Voltage	I/P-O/P: 1.5 KVAC, I/P-FG: 1.5 KVAC	I/P-O/P: 1.5 KVAC, I/P-FG: 1.5 KVAC
OTHERS		
MTBF	100,000 hrs min SR332 (40°C)	100,000 hrs min SR332 (40°C)
Dimension	100x31x14 0mm (LxWxH)	100x31x140 mm (LxWxH)
Weight	356g	358g
DC Connector	6-contact terminal block	6-contact terminal block
Data IN / PoE OUT	RJ45 Shielded Socket	RJ45 Shielded Socket
NOTES		
1 All parameters not specifically mentioned are measured at 24 VDC / 54 VDC input, rated load and 25°C of ambient temperature.		
2 Ripple current is measured at 20MHz of bandwidth. The measured terminal is paralleled with a 47uF E-cap and a 0.1uF Ceramic cap.		
3 <500Hz Vp-p=500mV; 500 Hz to 150 kHz Vp-p=200mV; 150 kHz to 500 kHz Vp-p=150mV; 500 kHz to 1MHz Vp-p=100mVp=150mV		
4 Excluding area of terminal block, SKU 30W complies to industrial rated IP30.		
5 Do not operate above 2000 meters in altitude.		

Product Documentation

For product documentation, visit: www.extremenetworks.com/documentation

Contact

Extreme Networks, Inc.
145 Rio Robles
San Jose, CA 95134 USA
Tel: +1 408-579-2800
Toll-free: +1 888-257-3000

Getting Help

For additional support related to this document, contact Extreme Networks using one of the following methods:

Product Documentation	www.extremenetworks.com/documentation
Phone	1-800-998-2408 (toll-free in U.S. and Canada) or +1-603-952-5000 For the Extreme Networks Support toll-free number in your country: http://support.extremenetworks.com/
Email	support@extremenetworks.com To expedite your message, enter the product name in the subject of your message.
The latest image and release notes	http://support.extremenetworks.com/

Legal Notices

Copyright © 2016 Extreme Networks, Inc. All Rights Reserved.

Extreme Networks, Inc., on behalf of or through its wholly-owned subsidiary, Enterasys Networks, Inc., reserves the right to make changes in specifications and other information contained in this document and its website without prior notice. The reader should in all cases consult representatives of Extreme Networks to determine whether any such changes have been made.

The hardware, firmware, software, or any specifications described or referred to in this document are subject to change without notice.

Trademarks

Extreme Networks and the Extreme Networks logo are trademarks or registered trademarks of Extreme Networks, Inc. in the United States and/or other countries.

All other names (including any product names) mentioned in this document are the property of their respective owners and may be trademarks or registered trademarks of their respective companies/owners.

For additional information on Extreme Networks trademarks, please see: www.extremenetworks.com/company/legal/trademarks/

Regulatory and Compliance Information

Extreme Networks Certificate List

EMC CONDUCTION & RADIATION	CISPR/EN 55032
	EN 55011
	47 CFR Part 15
	ICES-003
	CISPR/EN 55024
	IEC 61000-6-2
	EN50121-4
Safety	IEC 60950-1 CB Scheme Report All National Deviations
	UL/cUL60950-1
	UL 61010-2-201 (replaces UL508)
Tier 2 Approval	Taiwan BSMI
	Korea KCC
	Russia CU Cert

Federal Communications Commission (FCC) Notice

This device complies with Part 15 of the FCC rules. Operation is subject to the following two conditions: (1) this device may not cause harmful interference, and (2) this device must accept any interference received, including interference that may cause undesired operation. NOTE: This equipment has been tested and found to comply with the limits for a class A digital device, pursuant to Part 15 of the FCC rules. These limits are designed to provide reasonable protection against harmful interference when the equipment is operated in a commercial environment. This equipment uses, generates, and can radiate radio frequency energy and if not installed in accordance with the operator's manual, may cause harmful interference to radio communications. Operation of this equipment in a residential area is likely to cause interference in which case the user will be required to correct the interference at his own expense. WARNING: Changes or modifications made to this device which are not expressly approved by the party responsible for compliance could void the user's authority to operate the equipment.

Industry Canada Notice

This digital apparatus does not exceed the class A limits for radio noise emissions from digital apparatus set out in the Radio Interference Regulations of the Canadian Department of Communications.

Le présent appareil numérique n'émet pas de bruits radioélectriques dépassant les limites applicables aux appareils numériques de la class A prescrites dans le Règlement sur le brouillage radioélectrique édicté par le ministère des Communications du Canada.

Class A ITE Notice

WARNING: This is a Class A product. In a domestic environment this product may cause radio interference in which case the user may be required to take adequate measures.

BSMI EMC Statement – Taiwan

警告使用者：
此為甲類資訊技術設備，於居住環境中使用時，可能會造成射頻擾動，在此種情況下，使用者會被要求採取某些適當的對策。

Korea EMC Statement (KCC)

이 기기는 업무용(A급) 전자파적합기기로서 판매자 또는 사용자는 이 점을 주의 하시기 바라며, 가정 외의 지역에서 사용하는 것을 목적으로 합니다.

产品说明书附件 Supplement to Product Instructions

部件名称 (Parts)	有毒有害物质或元素 (Hazardous Substance)					
	铅 (Pb)	汞 (Hg)	镉 (Cd)	六价铬 (Cr ⁶⁺)	多溴联苯 (PBB)	多溴二苯醚 (PBDE)
金属部件 (Metal Parts)	×	○	○	×	○	○
电路模块 (Circuit Modules)	×	○	○	×	○	○
电缆及电缆组件 (Cables & Cable Assemblies)	×	○	○	×	○	○
塑料和聚合物部件 (Plastic and Polymeric parts)	○	○	○	○	○	×
电路开关 (Circuit Breakers)	○	○	×	×	○	○

○：表示该有毒有害物质在该部件所有均质材料中的含量均在 SJ/T 11363-2006 标准规定的限量要求以下。
Indicates that the concentration of the hazardous substance in all homogeneous materials in the parts is below the relevant threshold of the SJ/T 11363-2006 standard.

×：表示该有毒有害物质至少在该部件的某一均质材料中的含量超出 SJ/T 11363-2006 标准规定的限量要求。
Indicates that the concentration of the hazardous substance of at least one of all homogeneous materials in the parts is above the relevant threshold of the SJ/T 11363-2006 standard.

对销售之日的所售产品，本表显示，
凯创供应链的电子产品信息可能包含这些物质。注意：在所售产品中可能会也可能不会含有所有列出的部件。
This table shows where these substances may be found in the supply chain of Extreme's electronic information products, as of the date of sale of the enclosed product. Note that some of the component types listed above may or may not be a part of the enclosed product.

除非另外特别的标注，此标志为针对所涉及产品的环保使用期标志。某些零部件会有一个不同的环保使用期(例如，电池单元模块)贴在其产品上。
此环保使用期限只适用于产品是在产品手册中所规定的条件下工作。
The Environmentally Friendly Use Period (EFUP) for all enclosed products and their parts are per the symbol shown here, unless otherwise marked. Certain parts may have a different EFUP (for example, battery modules) and so are marked to reflect such. The Environmentally Friendly Use Period is valid only when the product is operated under the conditions defined in the product manual.

Hazardous Substances

This product complies with the requirements of Directive 2011/65/EU of the European Parliament and of the Council of 8 June 2011 on the restriction of the use of certain hazardous substances in electrical and electronic equipment.

European Waste Electrical and Electronic Equipment (WEEE) Notice

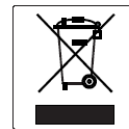

In accordance with Directive 2012/19/EU of the European Parliament on waste electrical and electronic equipment (WEEE):

- The symbol above indicates that separate collection of electrical and electronic equipment is required.
 - When this product has reached the end of its serviceable life, it cannot be disposed of as unsorted municipal waste. It must be collected and treated separately.
 - It has been determined by the European Parliament that there are potential negative effects on the environment and human health as a result of the presence of hazardous substances in electrical and electronic equipment.
 - It is the users' responsibility to utilize the available collection system to ensure WEEE is properly treated.
- For information about the available collection system, please contact Extreme Customer Support at +353 61 705500 (Ireland).

Extreme Networks PoE Injector

Quick Reference

16805 POE INJ-75W-24 & 16806 POE INJ-30W-24