

ExtremeSwitching VDX 6740 Hardware Installation Guide

© 2018, Extreme Networks, Inc. All Rights Reserved.

Extreme Networks and the Extreme Networks logo are trademarks or registered trademarks of Extreme Networks, Inc. in the United States and/or other countries. All other names are the property of their respective owners. For additional information on Extreme Networks Trademarks please see www.extremenetworks.com/company/legal/trademarks. Specifications and product availability are subject to change without notice.

Contents

Preface	7
Document conventions.....	7
Notes, cautions, and warnings.....	7
Text formatting conventions.....	7
Command syntax conventions.....	8
Extreme resources.....	8
Document feedback.....	8
Contacting Extreme Technical Support.....	9
About This Document	11
Supported hardware and software.....	11
What's new in this document.....	11
Product Overview	13
Product features.....	13
FlexPort.....	14
Using the VDX 6740T as a DHCP server.....	15
Extreme Networks inter-switch link trunks.....	16
Supported transceivers.....	17
Extreme Networks inter-switch link trunks.....	17
Hardware components.....	18
Port side view	19
Nonport side view.....	20
Extreme Networks inter-switch link trunks.....	22
Preparing for the Installation	25
Installation and safety considerations.....	25
Power precautions.....	25
Environmental precautions.....	26
EIA rack considerations.....	26
Recommendations for cable management.....	26
Items required for the installation.....	27
Items included with the device.....	27
Mounting the Device	29
Mounting options.....	29
Mounting precautions.....	30
Standalone installation	30
Installing the 1U Slim Rail Rack Mount Kit for Four-Post Racks (XBR-000291).....	31
Time and items required.....	31
Parts List.....	31
Attaching the front brackets.....	32
Installing the device in the rack.....	33
Attaching the rear brackets to the front brackets.....	34
Attaching the rear brackets to the rack rails.....	35
Installing the 1U, 1.5U, and 2U Universal Kit for Four Post Racks (XBR-R000295).....	35
Time and items required.....	36
Parts list.....	36

Flush-front mounting the device in the rack.....	37
Attaching the front brackets.....	38
Attaching the bracket extensions to the device.....	39
Installing the device in the rack.....	40
Attaching the rear brackets to the extensions.....	41
Attaching the rear brackets to the rack posts.....	43
Flush-rear (recessed) mounting the device in the rack.....	44
Attaching the front brackets to the rear of the device.....	44
Attaching the bracket extensions to the front of the device.....	45
Installing the device in the rack.....	46
Attaching the rear brackets to the bracket extensions at the front of the device.....	47
Attaching the rear brackets to the front rack posts.....	49
Installing the 1U, 1.5U, and 2U Mid-Mount Kit for Two-Post Racks (XBR-000165, XBR-000175, and XBR-R000292).....	50
Time and items required.....	51
Parts list.....	51
Attaching the front brackets to the device.....	52
Attaching the device to a rack.....	53
Attaching the rear brackets to the rack.....	54
Attaching the rear brackets to the device.....	55
Installing the 1U and 2U Flush-Mount Rack Kit for Two-Post Racks (XBR-000307 and XBR-R000293).....	56
Time and items required.....	56
Parts list.....	57
Attaching the front brackets to the device.....	58
Attaching the front brackets to the rack.....	59
Attaching the rear brackets to the rack.....	59
Attaching the rear brackets to the device.....	60
Installing the Universal Four-Post Rack Kit (XBR-R000296).....	61
Time and items required.....	62
Parts list.....	62
Flush-front mounting.....	64
Flush-rear (recessed) mounting.....	69
Installing the Universal Two-Post Rack Kit (XBR-R000294).....	74
Time and items required.....	75
Parts list.....	75
Flush-front mounting.....	76
Mid-mounting.....	80
Initial Configuration.....	85
Configuration overview.....	85
Items required.....	86
Providing power to the device.....	86
Connecting an AC power cord.....	86
Connecting a power cord to a 500W DC power supply.....	87
Connecting a DC power cord to a 250W DC power supply.....	88
Verifying operation.....	89
Establishing a serial connection.....	89
Assigning permanent passwords	90
Changing the default account passwords	90
Configuring the device IP address.....	91
Using DHCP to set the IP address.....	91
Setting a static IP address.....	91

Stateless IPv6 autoconfiguration.....	92
Setting stateless IPv6 autoconfiguration.....	92
Setting the date and time	93
Time zones.....	93
Time synchronization.....	93
Synchronizing local time using NTP.....	93
Setting the clock (date and time) manually.....	94
Setting the time zone.....	94
Changing the RBridge ID and VCS ID.....	95
Network device connections.....	95
Ethernet or Fast Ethernet hubs.....	95
Workstations, servers, or routers.....	95
Network device.....	95
Testing connectivity.....	96
Upgrading port speeds on the VDX 6740T.....	96
Operation and Maintenance.....	99
LED activity interpretation.....	99
LEDs.....	99
LED locations.....	99
LED patterns.....	101
POST and boot specifications.....	104
POST.....	104
Boot.....	104
Interpreting POST results.....	104
Powering off the device.....	105
Thermal operations.....	105
Device maintenance.....	105
Installing an Ethernet SFP+ transceiver.....	105
Installing a FC SFP+.....	106
Diagnostic tests.....	107
Upgrading firmware.....	108
Device management.....	108
Removal and Replacement Procedures.....	109
Before beginning replacement	109
FRU replacement in a VDX 6740.....	110
Determining the need to replace an assembly.....	111
Time and items required.....	111
Replacing the power supply and fan assembly.....	111
FRU replacement in the VDX 6740T.....	112
Determining the need to replace a power supply.....	113
Time and items required to replace a power supply.....	113
Replacing a 500W AC power supply.....	113
Determining the need to replace a fan assembly.....	115
Time and items required to replace a fan assembly.....	115
Replacing a fan assembly.....	115
Technical Specifications.....	117
ExtremeSwitching VDX 6740 Switch Technical Specifications.....	117
System specifications.....	117
Ethernet.....	117

LEDs.....	117
Other.....	118
Weight and physical dimensions.....	118
Environmental requirements.....	118
Power supply specifications (per PSU).....	119
Power consumption VDX 6740 and VDX 6740T (idle configuration).....	119
Power consumption VDX 6740 (typical configuration).....	120
Power consumption VDX 6740T (typical configuration).....	120
Power consumption VDX 6740 and 6740T (maximum configuration).....	121
Data port specifications (Ethernet).....	121
Serial port specifications (pinout mini-USB).....	121
Serial port specifications (pinout RJ-45).....	122
Serial port specifications (protocol).....	122
Memory specifications.....	122
Regulatory compliance (EMC).....	122
Regulatory compliance (safety).....	123
Regulatory compliance (environmental).....	123
Regulatory Statements.....	125
BSMI statement (Taiwan).....	125
Canadian requirements.....	125
CE statement.....	125
China ROHS.....	126
FCC warning (US only).....	126
Germany statement.....	126
KCC statement (Republic of Korea).....	126
VCCI statement.....	126
Japan power cord	127
Cautions and Danger Notices.....	129
Cautions.....	129
General cautions.....	129
Electrical cautions.....	131
Danger Notices.....	133
General dangers.....	134
Electrical dangers.....	134
Dangers related to equipment weight.....	134
Laser dangers.....	135

Preface

- Document conventions..... 7
- Extreme resources..... 8
- Document feedback..... 8
- Contacting Extreme Technical Support..... 9

Document conventions

The document conventions describe text formatting conventions, command syntax conventions, and important notice formats used in Extreme technical documentation.

Notes, cautions, and warnings

Notes, cautions, and warning statements may be used in this document. They are listed in the order of increasing severity of potential hazards.

NOTE

A Note provides a tip, guidance, or advice, emphasizes important information, or provides a reference to related information.

ATTENTION

An Attention statement indicates a stronger note, for example, to alert you when traffic might be interrupted or the device might reboot.



CAUTION

A Caution statement alerts you to situations that can be potentially hazardous to you or cause damage to hardware, firmware, software, or data.



DANGER

A Danger statement indicates conditions or situations that can be potentially lethal or extremely hazardous to you. Safety labels are also attached directly to products to warn of these conditions or situations.

Text formatting conventions

Text formatting conventions such as boldface, italic, or Courier font may be used to highlight specific words or phrases.

Format	Description
bold text	Identifies command names. Identifies keywords and operands. Identifies the names of GUI elements.
<i>italic text</i>	Identifies text to enter in the GUI. Identifies emphasis. Identifies variables.
Courier font	Identifies document titles. Identifies CLI output.

Format	Description
	Identifies command syntax examples.

Command syntax conventions

Bold and italic text identify command syntax components. Delimiters and operators define groupings of parameters and their logical relationships.

Convention	Description
bold text	Identifies command names, keywords, and command options.
<i>italic text</i>	Identifies a variable.
[]	Syntax components displayed within square brackets are optional. Default responses to system prompts are enclosed in square brackets.
{ x y z }	A choice of required parameters is enclosed in curly brackets separated by vertical bars. You must select one of the options.
x y	A vertical bar separates mutually exclusive elements.
< >	Nonprinting characters, for example, passwords, are enclosed in angle brackets.
...	Repeat the previous element, for example, <i>member[member...]</i> .
\	Indicates a "soft" line break in command examples. If a backslash separates two lines of a command input, enter the entire command at the prompt without the backslash.

Extreme resources

Visit the Extreme website to locate related documentation for your product and additional Extreme resources.

White papers, data sheets, and the most recent versions of Extreme software and hardware manuals are available at www.extremenetworks.com. Product documentation for all supported releases is available to registered users at www.extremenetworks.com/support/documentation.

Document feedback

Quality is our first concern at Extreme, and we have made every effort to ensure the accuracy and completeness of this document. However, if you find an error or an omission, or you think that a topic needs further development, we want to hear from you.

You can provide feedback in two ways:

- Use our short online feedback form at <http://www.extremenetworks.com/documentation-feedback-pdf/>
- Email us at internalinfodev@extremenetworks.com

Provide the publication title, part number, and as much detail as possible, including the topic heading and page number if applicable, as well as your suggestions for improvement.

Contacting Extreme Technical Support

As an Extreme customer, you can contact Extreme Technical Support using one of the following methods: 24x7 online or by telephone. OEM customers should contact their OEM/solution provider.

If you require assistance, contact Extreme Networks using one of the following methods:

- [GTAC \(Global Technical Assistance Center\)](#) for immediate support
 - Phone: 1-800-998-2408 (toll-free in U.S. and Canada) or +1 408-579-2826. For the support phone number in your country, visit: www.extremenetworks.com/support/contact.
 - Email: support@extremenetworks.com. To expedite your message, enter the product name or model number in the subject line.
- [GTAC Knowledge](#) - Get on-demand and tested resolutions from the GTAC Knowledgebase, or create a help case if you need more guidance.
- [The Hub](#) - A forum for Extreme customers to connect with one another, get questions answered, share ideas and feedback, and get problems solved. This community is monitored by Extreme Networks employees, but is not intended to replace specific guidance from GTAC.
- [Support Portal](#) - Manage cases, downloads, service contracts, product licensing, and training and certifications.

Before contacting Extreme Networks for technical support, have the following information ready:

- Your Extreme Networks service contract number and/or serial numbers for all involved Extreme Networks products
- A description of the failure
- A description of any action(s) already taken to resolve the problem
- A description of your network environment (such as layout, cable type, other relevant environmental information)
- Network load at the time of trouble (if known)
- The device history (for example, if you have returned the device before, or if this is a recurring problem)
- Any related RMA (Return Material Authorization) numbers

About This Document

- Supported hardware and software.....11
- What's new in this document.....11

Supported hardware and software

This document includes information specific to the ExtremeSwitching VDX 6740 and ExtremeSwitching VDX 6740T running Extreme Network OS version 7.1.0 and later.

The VDX 6740T information in this guide also covers the VDX 6740T-1G variant running Extreme Network OS version 7.1.0 and later.

The VDX 6740 and VDX 6740T were first supported at Network OS 4.0.0.

What's new in this document

On October 30, 2017, Extreme Networks, Inc. acquired the data center networking business from Brocade Communications Systems, Inc. This document has been updated to remove or replace references to Brocade Communications, Inc. with Extreme Networks, Inc., as appropriate.

Product Overview

- [Product features.....](#) 13
- [Hardware components.....](#) 18

Product features

The ExtremeSwitching VDX 6740 product family includes three top-of-rack, Gigabit Ethernet (GbE) line-rate, low latency, lossless Data Center Bridging (DCB) devices:

The VDX 6740 has the following features:

- Base models support 24 Ethernet ports. A 10G Port Upgrade license can add ports in increments of 8, 16, and 24 ports, for a total of 48 Ethernet ports. The following types of optics can be installed in these ports:
 - 1/10 GbE ports operating at 1 Gbps, 10 Gbps, or in auto-sensing mode (1 or 10 Gbps).
 - 1 GbE copper optics, operating at 1 Gbps and 100 Mbps.
 - 8 Gbps Fibre channel optics operating at 2, 4, and 8 Gbps and 16 Gbps optics operating at 4, 8, and 16 Gbps when the FlexPort feature is used.
- Base models do not support 40 GbE ports, but a 40G Port Upgrade license can add two or four 40 GbE ports. Only 4x10 GbE QSFP+ optics can be installed in these ports as FlexPort is not supported on the 40 GbE ports.

The VDX 6740T has the following features:

- Base models support 24 Ethernet ports. A 10G Port Upgrade license can add ports in increments of 8, 16, and 24 ports, for a total of 48 Ethernet ports. These ports support Base-T (RJ-45) transceivers operating at 100 Mbps, 1 Gbps, 10 Gbps, or in auto-sensing mode.
- Base models do not contain 40 GbE ports, but a 40G Port Upgrade license can add two or four 40 GbE ports. These ports support the following optics:
 - 40 GbE optics
 - 4x10 GbE QSFP+ optics.
 - 4x16 Fibre Channel QSFP+ optics if the FlexPort feature is used. Fibre Channel operation is supported on 40-GbE ports configured in SFP breakout mode (also referred to as 4x10 GbE breakout mode) that use qualified 4x16 Fibre Channel QSFP+ optics.

The VDX 6740T-1G variant has the following features:

- Base models are fully populated with 48 Ethernet ports. These ports support Base-T (RJ-45) transceivers operating at 100 Mbps, 1 Gbps, or in auto-sensing mode. A 10G Port Upgrade license enables port operation at 100 Mbps, 1 Gbps, 10 Gbps, or in auto-sensing mode. This upgrade can be installed in increments of 16, 32, and 48 ports.
- Base models contain two 40 GbE ports. A 40G Port Upgrade license can be added for two additional 40 GbE ports. These ports support the following optics:
 - 40 GbE optics
 - 4x10 GbE QSFP+ optics.
 - 4x16 Fibre Channel QSFP+ optics if the FlexPort feature is used. Fibre Channel operation is supported on 40-GbE ports configured in 40 GbE mode that use qualified 4x16 Fibre Channel QSFP+ optics.

For all models, the 40 GbE port can be reconfigured as four 10 GbE ports in SFP breakout mode (also referred to as 4x10 GbE breakout mode). Thus, the device can be configured with as many as 64 10 GbE ports. For instructions on configuring breakout mode, refer to the "SFP breakout" section of the *Extreme Network OS Management Configuration Guide*.

The VDX 6740 devices run on the Extreme Network OS v4.0.0 or later. The 100 Mbps speed for Base-T ports on the VDX 6740T is available with Extreme Network OS v4.1.0 and later. For details about Extreme Network OS, refer to the *Extreme Network OS Management Configuration Guide*.

A key feature of this device is ExtremeSwitching VCS™ technology, which includes virtual cluster switching, a set of technologies that allows users to create flatter, virtualize, and converged data center networks. VCS fabrics are scalable, permitting users to expand at their own pace, and simplified, allowing users to manage the fabric as a single entity. VCS-based Ethernet fabrics are convergence-capable with technologies such as Fibre Channel over Ethernet (FCoE) for storage.

This device can also be deployed in IP fabrics. An IP fabric can be described as a collection of discrete Layer 3 elements (such as switch-routers) arranged in a spine-leaf network. These elements exchange Layer 2 and Layer 3 database information to provide a flexible, non-blocking and scalable framework while retaining the semantics of a single logical switch. There can be competing protocols for exchanging this distributed database across such discrete elements. Spine-leaf networks are designed to be a three-stage architecture, an ingress stage, a middle stage, and an egress stage. The concept is that there are multiple paths for the call to be switched through the network so that traffic can always connect and not be blocked. For full details and configuration procedures for IP fabrics, refer to the *Extreme Network OS IP Fabrics Configuration Guide*.

FlexPort

The FlexPort feature is supported on the VDX 6740 with Network OS 5.0.0 and later and on the VDX 6740T with Network OS 6.0.0 and later. This feature allows you to attach a FC device to run encapsulated FC over Ethernet (FCOE) traffic through the device.

To configure FlexPort and Fibre Channel operation for specific VDX 6740 ports, follow steps in the "FlexPort" section of the *Network OS Management Configuration Guide*.

FlexPort allows you to configure specific groups of ports, called connector groups, as 10 Gbps Ethernet ports or as Fibre Channel (FC) ports. Up to 32 ports can be configured as FlexPorts. These ports can be changed from Ethernet to Fibre Channel operation without a reboot. Qualified 10 GbE SFP+ transceivers or 4x10 GbE breakout cables must be installed to allow Ethernet operation. Qualified 8 Gbps FC, 16 Gbps FC, or 4x16G QSFP+ transceivers must be installed to allow Fibre Channel operation.

Connector groups share common speed and protocol type properties. You can configure the following speed and protocol combinations in each connector group:

- **LowMixed** - 2, 4, and 8 Gbps FC and 1/10 Gbps Ethernet
- **HighMixed** - 16 Gbps FC and 10 Gbps Ethernet only
- **FibreChannel** - 2, 4, 8, and 16 Gbps FC (no Ethernet)

For the VDX 6740T, Ethernet operation is supported on 40 GbE QSFP ports configured in 40 GbE mode that use qualified 40 GbE transceivers and on 40 GbE ports in SFP breakout mode (also referred to as 4x10 GbE breakout mode) that use qualified 4x10 GbE QSFP transceivers. Fibre Channel operation is supported on 40 GbE ports configured in SFP breakout mode that use qualified 4x16 QSFP+ transceivers. FlexPort is not supported on 40 GbE QSFP ports on the VDX 6740.

The default port FlexPort setting is Ethernet. Consider the following for Fibre Channel operation and ISL connections:

- Ports that do not support the Fibre Channel protocol are not allowed to have their connector group setting changed from the default setting.
- When the system is booted up, by default, a FlexPort can become an ISL port because it is an Ethernet port in no-shut state. However, if the FlexPort is configured as FC port, it won't become an ISL port.

For details on the FlexPort feature, including port ranges on VDX 6740 models that can be configured as FlexPorts, connector groups, and configuration procedures, refer to the *Network OS Management Configuration Guide*.

Using the VDX 6740T as a DHCP server

You can connect the VDX 6740T to the management port on any Extreme Networks switch (DHCP client) and use the VDX 6740T as a DHCP server to support DHCP Automatic Deployment (DAD), DHCP zero touch provisioning (ZTP), obtaining switch IP addresses, and other services.

The following steps provide an example for connecting a VDX 6740T as a DHCP server to a VDX 6740 functioning as the DHCP client.

- Connect the VDX 6740T Ethernet management port to any of the VDX 6740T inband 10 GbE BaseT ports using a CAT5 cable.
- Connect the VDX 6740 Ethernet management port to any of the 10 GbE ports on the VDX 6740T using a CAT5 cable.

FIGURE 1 Connecting VDX 6740T as DHCP server to VDX 6740

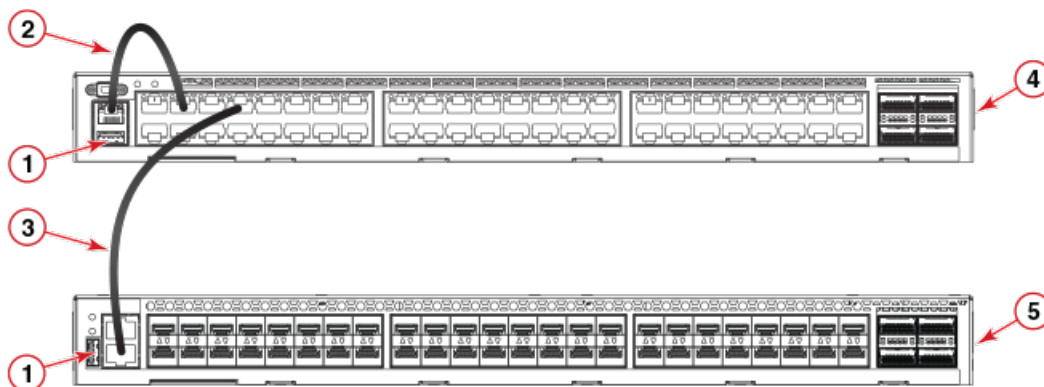

- | | |
|---|--------------|
| 1. Ethernet management port (RJ45) | 4. VDX 6740T |
| 2. CAT5 cable from management port to an VDX 6740T inband port | 5. VDX 6740 |
| 3. CAT5 cable from VDX 6740T inband port to VDX 6740 Ethernet management port | |

Following are general steps to configure the VDX 6740T as a DHCP server. For detailed procedures and Fabric OS commands, refer to the *Extreme Network OS Management Configuration Guide*.

- Set up the DHCP pool address and other parameters in the `dhcp.conf` file.
- Configure a static IP address for the management port (DHCP must be disabled), then enable DHCP on the port.
- Configure the VDX 6740T inband ports that you are using for DHCP server connections into a VLAN so that the client switches can obtain DHCP IP addresses from the server.
- Download the `dhcpd.conf` file to the VDX 6740T. A valid `dhcpd.conf` file must be copied into the device before enabling the DHCP server.

Following are requirements and considerations for this feature:

- VDX 6740T is supported as the DHCP server and connected Extreme Networks switch is supported as a DHCP client.
- DHCP server must run as a standalone switch; it cannot be enabled when the switch is part of a VCS cluster.
- DHCPv6 is not supported.
- DHCP server can support up to 20 clients.
- DHCP server is not supported on inband ports without IP loopback and DHCP server support on the management port.
- DHCP configuration with a multiple subnet is not supported.
- DHCP only runs on the active CP. HA failover is supported.

- "DHCP relay" must be disabled since the DHCP server uses the same port number. Enabling and disabling DHCP automatically toggles "dhcp relay" and forces a switch reboot.

Extreme Networks inter-switch link trunks

In VCS mode, unless specifically disabled, inter-switch link (ISL) Extreme Networks trunking between adjacent devices is automatic. All ports must be in the same port group and must be configured at the same speed. There is a limit of sixteen ports per trunk group. No separate licensing is required. Refer to the illustrations below for the exact port groups. On the VDX 6740T, ports in groups 3 and 3A, as well as port groups 4 and 4A, cannot be trunked together. However, these ports can be trunked on the VDX 6740 when the 40 GbE QSFP ports are configured in breakout mode. VDX 6740T 1GbE ports cannot be trunked.

NOTE

If connections are made to 16 different switches, only eight ports will be trunk ports while the other eight ports will be normal ISL ports.

For instructions on configuring breakout mode and Extreme Networks trunking, refer to the *Extreme Network OS Management Configuration Guide*.

FIGURE 2 Port groups of the VDX 6740

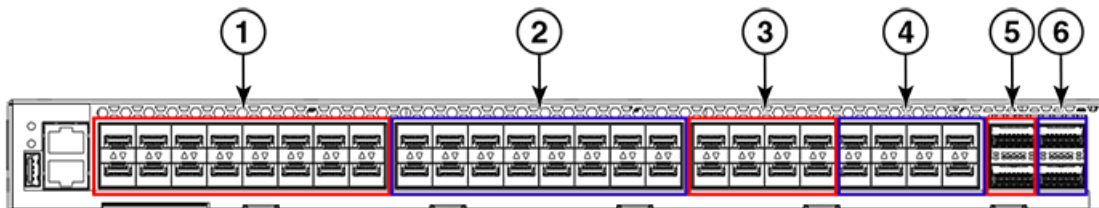

- | | |
|---|---|
| 1. Trunk Group 1 - 1/10 GbE SFP ports 1-16 | 4. Trunk group 4 - 1/10 GbE SFP ports 41-48 |
| 2. Trunk Group 2 - 1/10 GbE SFP ports 17-32 | 5. Trunk Group 3A - 40 GbE QSFP ports 49-50 |
| 3. Trunk Group 3 - 1/10 GbE SFP ports 33-40 | 6. Trunk Group 4A - 40 GbE QSFP ports 51-52 |

FIGURE 3 Port groups of the VDX 6740T

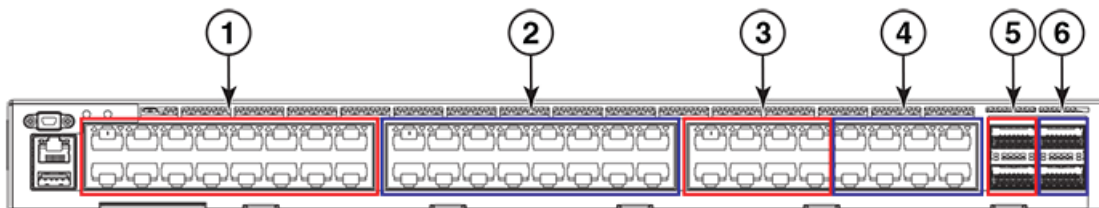

- | | |
|---|---|
| 1. Trunk Group 1 - 1/10 GbE BaseT ports 1-16 | 4. Trunk Group 4 - 1/10 GbE BaseT ports 41-48 |
| 2. Trunk Group 2 - 1/10 GbE BaseT ports 17-32 | 5. Trunk Group 3A - 40 GbE QSFP ports 49-50 |
| 3. Trunk Group 3 - 1/10 GbE BaseT ports 33-40 | 6. Trunk Group 4A - 40 GbE QSFP ports 51-52 |

NOTE

For the VDX 6740T-1G variant, if you release Dynamic Ports On Demand (DPOD) licenses from any 10GbE ports on a 16-port trunk configured with static 10G speed, reserve back those licenses, then perform the **shutdown** and **no shutdown** commands on all trunk ports, the trunk bandwidth will not restore to the maximum 160 Gbps.

Supported transceivers

The VDX 6740 provides up to 48 ports that support 1, 8, or 10 GbE optical SFP+ Extreme-branded Ethernet SFP+ optical or copper transceivers. These ports also support SFP+ direct-attached Twinax copper and active and passive optical cables.

VDX 6740 ports also support 10 GbE tunable SFP+ (TSFP+) transceivers. If used, TSFP+ transceivers must be installed in the port at each end of a link and "tuned" to the same wavelength. If not, the link may come online, but operation may be unpredictable. If wavelength difference exceeds a specified limit, a RASLOG message occurs and the port is taken offline. You can configure wavelengths for installed transceivers using channel numbers from 1 to 102 that correspond to wavelengths from 1568.77 to 1528.38 nm using the **tunable-optics sfpp channel** *channel number* command. For details on using this and related commands, refer to the "Tunable SFP+ optics" section of the *Extreme Network OS Management Configuration Guide*.

The VDX 6740T provides 48 ports with 10G Base-T RJ-45 connectors for copper twisted-pair only.

Both the VDX 6740 and VDX 6740T provide four ports that support 40 GbE QSFP+ transceivers. These ports support SFP breakout mode (also referred to 4x10 GbE breakout mode) using 4x10 GbE breakout cables. Fibre Channel FlexPort operation is supported only when ports are in 40 GbE mode using optical 4x16G QSFP+ short wavelength transceivers. On the VDX 6740T, the 40 GbE ports also support 10 GbE SFP+ transceivers when the QSA Adapter is used.

For details on supported transceivers for all VDX 6940 models, refer to the *ExtremeSwitching VDX Transceiver Support Matrix*. Access this matrix on the www.extremenetworks.com website by selecting *Product and Services* from the menu, scroll down *Transceivers*, and then select *Transceiver Modules*. Also contact your Extreme Networks representative for current transceiver support and ordering information.

- *ExtremeSwitching VDX Transceiver Support Matrix*
- *Extreme Fibre Channel Transceiver Support Matrix*



DANGER

All fiber-optic interfaces use Class 1 lasers.



DANGER

Laser Radiation. Do Not View Directly with Optical Instruments. Class 1M Laser Products.

Extreme Networks inter-switch link trunks

In VCS mode, unless specifically disabled, inter-switch link (ISL) Extreme Networks trunking between adjacent devices is automatic. All ports must be in the same port group and must be configured at the same speed. There is a limit of sixteen ports per trunk group. No separate licensing is required. Refer to the illustrations below for the exact port groups. On the VDX 6740T, ports in groups 3 and 3A, as well as port groups 4 and 4A, cannot be trunked together. However, these ports can be trunked on the VDX 6740 when the 40 GbE QSFP ports are configured in breakout mode. VDX 6740T 1GbE ports cannot be trunked.

NOTE

If connections are made to 16 different switches, only eight ports will be trunk ports while the other eight ports will be normal ISL ports.

For instructions on configuring breakout mode and Extreme Networks trunking, refer to the *Extreme Network OS Management Configuration Guide*.

FIGURE 4 Port groups of the VDX 6740

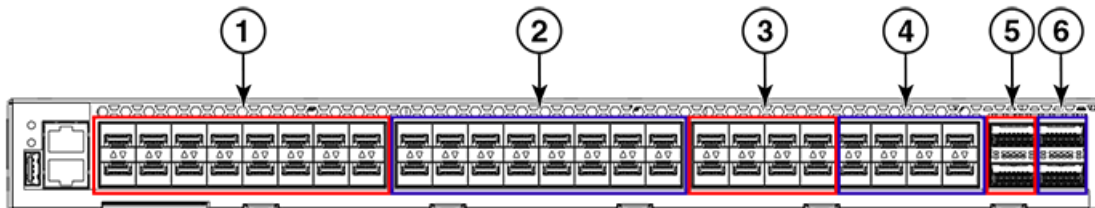

- | | |
|---|---|
| 1. Trunk Group 1 - 1/10 GbE SFP ports 1-16 | 4. Trunk group 4 - 1/10 GbE SFP ports 41-48 |
| 2. Trunk Group 2 - 1/10 GbE SFP ports 17-32 | 5. Trunk Group 3A - 40 GbE QSFP ports 49-50 |
| 3. Trunk Group 3 - 1/10 GbE SFP ports 33-40 | 6. Trunk Group 4A - 40 GbE QSFP ports 51-52 |

FIGURE 5 Port groups of the VDX 6740T

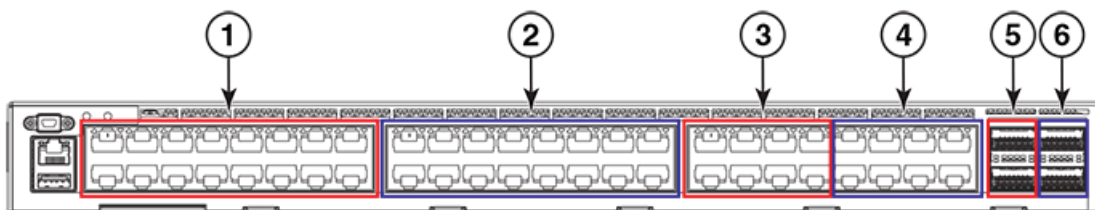

- | | |
|---|---|
| 1. Trunk Group 1 - 1/10 GbE BaseT ports 1-16 | 4. Trunk Group 4 - 1/10 GbE BaseT ports 41-48 |
| 2. Trunk Group 2 - 1/10 GbE BaseT ports 17-32 | 5. Trunk Group 3A - 40 GbE QSFP ports 49-50 |
| 3. Trunk Group 3 - 1/10 GbE BaseT ports 33-40 | 6. Trunk Group 4A - 40 GbE QSFP ports 51-52 |

NOTE

For the VDX 6740T-1G variant, if you release Dynamic Ports On Demand (DPOD) licenses from any 10GbE ports on a 16-port trunk configured with static 10G speed, reserve back those licenses, then perform the **shutdown** and **no shutdown** commands on all trunk ports, the trunk bandwidth will not restore to the maximum 160 Gbps.

Hardware components

VDX 6740 devices offer the following features and capabilities:

- The VDX 6740 has these features:
 - Up to 48 1/10 GbE optical SFP+ ports.
 - Up to four 40 GbE QSFP ports, each of which can be configured into four 10 GbE ports in SFP breakout mode (also referred to as 4x10 GbE breakout mode). These ports support optical or twinaxial breakout cable when ports are configured in SFP breakout mode.
 - Dual, hot-swappable 250W AC power supplies with three integrated cooling fans each. Power supplies and fans can be ordered with front-to-back or back-to-front airflow).
 - Four temperature sensors.
 - A reduced-depth, rack-mount design using existing rail kits - four-post fixed or Telco flush and mid-mount rack mount kits.
- The VDX 6740T has these features:
 - Up to 48 1/10G Base-T copper ports. These ports support 100 Mbps operation (Network OS v4.1.0 and later). Note that forty-eight 1G Base-T copper ports are supported on the VDX 6740T-1G variant, which can be upgraded to 1/10G operation through 10G Port Upgrade licensing.

- Up to four 40 GbE QSFP ports, each of which can be configured into four 10 GbE ports in SFP breakout mode (also referred to as 4x10 GbE breakout mode). These ports support optical or twinaxial breakout cable when ports are configured in SFP breakout mode.
 - A mini-USB-fronted serial (RS-232) port for terminal access and debugging.
 - Dual, hot-swappable 500W AC power supplies and five separate, hot-swappable fan units. Power supplies and fans can be ordered with front-to-back or back-to-front airflow).
 - Two temperature sensors.
 - Universal 4-post and 2-post rack mount kits.
- The VDX 6740 and VDX 6740T have the following features:
 - A system motherboard that features a Reduced Instruction Set Computer (RISC) CPU running at 1.5 GHz with integrated peripherals
 - An RJ-45 Ethernet out-of-band management port
 - An RJ-45-fronted serial (RS-232) port for terminal access and debugging
 - A USB port for firmware upgrades and system log downloads
 - Support for inter-switch link (ISL) Extreme Networks Trunking (10, 40, and 100 GbE ports only)
 - Extensive diagnostics and system-monitoring capabilities for enhanced high Reliability, Availability, and Serviceability (RAS)
 - Optimized airflow (a choice of front-to-back or back-to-front flow)
 - A real-time clock (RTC) with battery
 - EEPROM for device identification
 - Voltage monitoring
 - Fan monitoring
 - I²C interface to monitor and control environmental aspects

NOTE

Port numbering for the VDX 6740 begins with 1, not 0.

NOTE

To upgrade 1 Gbps port speed to 10 Gbps on the VDX 6740T-1G variant when installing the 10G Port Upgrade License, refer to [Upgrading port speeds on the VDX 6740T](#) on page 96.

**DANGER**

Batteries used for RTC/NVRAM backup are not located in operator-access areas. There is a risk of explosion if a battery is replaced by an incorrect type. Dispose of used components containing batteries according to the local ordinance and regulations.

Port side view

The port side of the VDX 6740 includes the system LEDs, management ports and LEDs, USB port, SFP+ ports, and the corresponding port status LEDs.

The following illustration shows the port side of the VDX 6740.

FIGURE 6 Port-side view of the VDX 6740

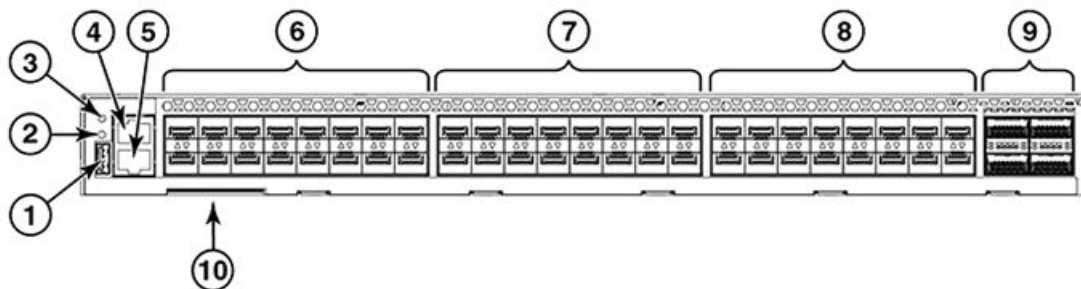

- | | |
|---|---|
| 1. USB port | 6. SFP+ ports 1 through 16 with status LEDs above* |
| 2. System power LED | 7. SFP+ ports 17 through 32 with status LEDs above* |
| 3. System status LED | 8. SFP+ ports 33 through 48 with status LEDs above* |
| 4. Serial console management port (RJ-45) | 9. 40 GbE QSFP ports 49 through 52 |
| 5. Ethernet port (RJ-45) | 10. Device ID pull-out tab |

*The FlexPort feature allows configuration of specific VDX 6740 ports as 1/10 GbE or 4, 8, or 16 Gbps FC ports.

The port side of the VDX 6740T includes the system LEDs, management ports and LEDs, USB port, and Base-T Ethernet ports and the corresponding port status LEDs.

The following illustration shows the port side of the VDX 6740T.

FIGURE 7 Port-side view of the VDX 6740T

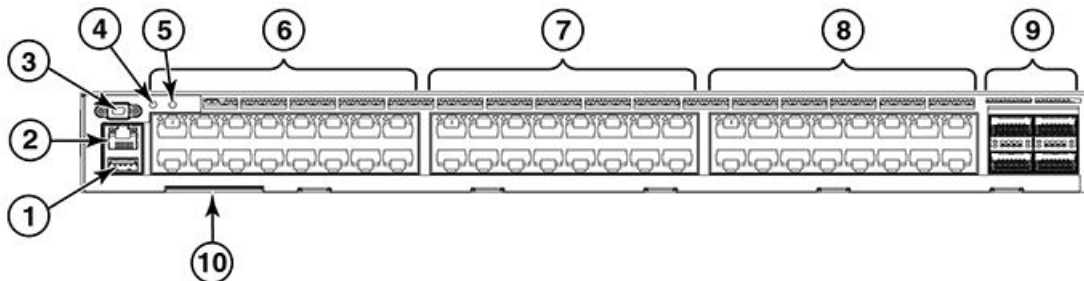

- | | |
|------------------------------------|---|
| 1. USB port | 6. 10 GbE BaseT ports 1 through 16 with status LEDs above* |
| 2. Ethernet management port (RJ45) | 7. 10 GbE BaseT ports 17 through 32 with status LEDs above* |
| 3. Serial console port (mini-USB) | 8. 10 GbE BaseT ports 33 through 48 with status LEDs above* |
| 4. System status LED | 9. 40 GbE QSFP ports 49 through 52** |
| 5. System power LED | 10. Device ID pull-out tab |

*Base ports on the VDX 6740T-1G variant operate at 1 Gbps and require Port Upgrade license to operate at 10 Gbps.

**FlexPort allows configuration of specific VDX 6740T 40 GbE QSFP+ ports as 1/10 GbE or 4, 8, or 16 Gbps FC ports.

Nonport side view

The following illustration shows the non-port side of the VDX 6740, which contains the combined power supply and fan assemblies.

FIGURE 8 Non-port-side view of the DC VDX 6740

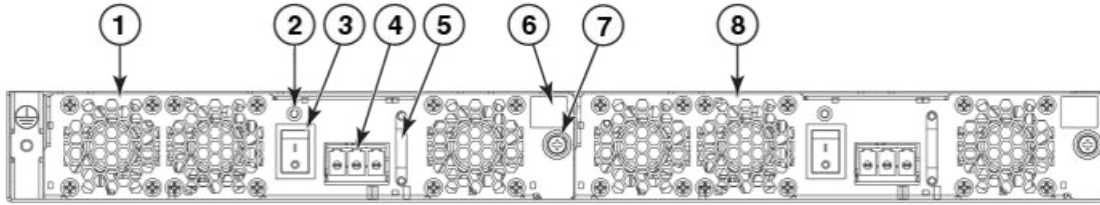

- | | |
|-------------------------------------|-------------------------------------|
| 1. Power supply and fan assembly #2 | 5. Handle |
| 2. Power supply and fan status LED | 6. Airflow label |
| 3. On/off switch | 7. Captive screw |
| 4. Power cord receptacle | 8. Power supply and fan assembly #1 |

FIGURE 9 Non-port-side view of the AC VDX 6740

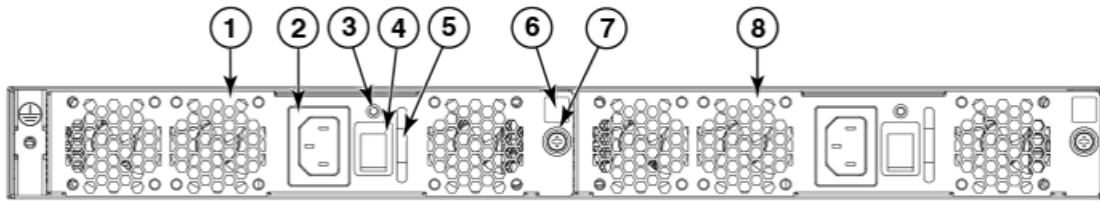

- | | |
|-------------------------------------|-------------------------------------|
| 1. Power supply and fan assembly #2 | 5. Handle |
| 2. Power cord receptacle | 6. Airflow label |
| 3. Power supply and fan status LED | 7. Captive screw |
| 4. On/off switch | 8. Power supply and fan assembly #1 |

The following illustration shows the non-port side of the VDX 6740T, which house the separate power supplies and fans.

NOTE

The un-numbered features on the DC power supply are identical to the features on the AC power supply.

FIGURE 10 Non-port-side view of the AC VDX 6740T

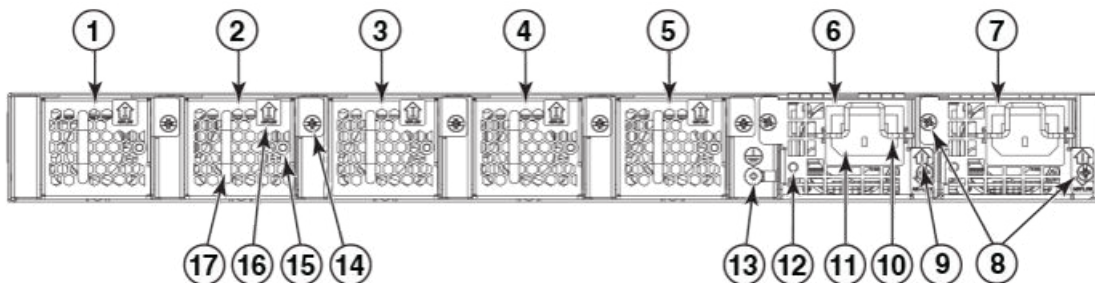

- | | |
|--------------------|---------------------|
| 1. Fan #1 | 10. Plug retainer |
| 2. Fan #2 | 11. Plug receptacle |
| 3. Fan #3 | 12. Status LED |
| 4. Fan #4 | 13. Ground lug |
| 5. Fan #5 | 14. Captive screw |
| 6. Power supply #1 | 15. Status LED |
| 7. Power supply #2 | 16. Airflow label |
| 8. Captive screws | 17. Handle |
| 9. Airflow label | |

FIGURE 11 Non-port-side view of the DC VDX 6740T

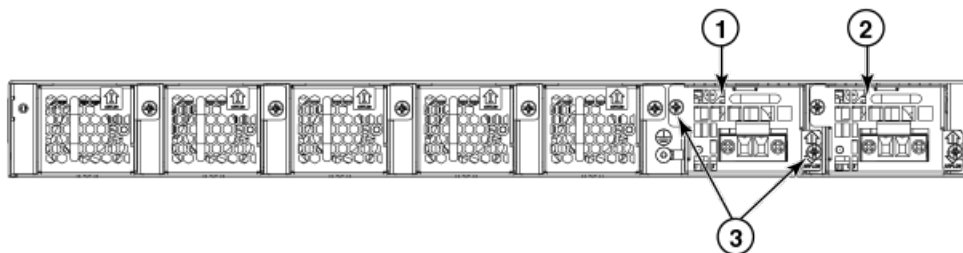

- | | |
|--------------------|-------------------|
| 1. Power supply #1 | 3. Captive screws |
| 2. Power supply #2 | |

Extreme Networks inter-switch link trunks

In VCS mode, unless specifically disabled, inter-switch link (ISL) Extreme Networks trunking between adjacent devices is automatic. All ports must be in the same port group and must be configured at the same speed. There is a limit of sixteen ports per trunk group. No separate licensing is required. Refer to the illustrations below for the exact port groups. On the VDX 6740T, ports in groups 3 and 3A, as well as port groups 4 and 4A, cannot be trunked together. However, these ports can be trunked on the VDX 6740 when the 40 GbE QSFP ports are configured in breakout mode. VDX 6740T 1GbE ports cannot be trunked.

NOTE

If connections are made to 16 different switches, only eight ports will be trunk ports while the other eight ports will be normal ISL ports.

For instructions on configuring breakout mode and Extreme Networks trunking, refer to the *Extreme Network OS Management Configuration Guide*.

FIGURE 12 Port groups of the VDX 6740

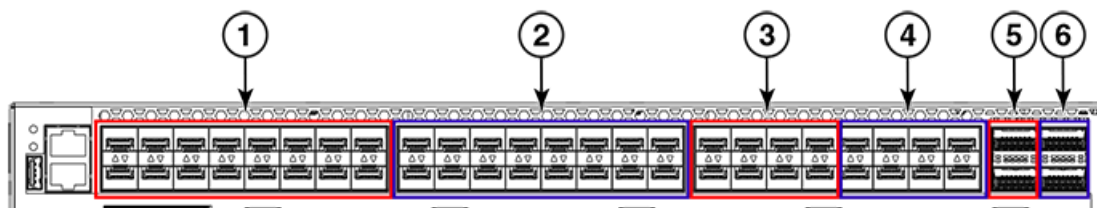

- | | |
|---|---|
| 1. Trunk Group 1 - 1/10 GbE SFP ports 1-16 | 4. Trunk group 4 - 1/10 GbE SFP ports 41-48 |
| 2. Trunk Group 2 - 1/10 GbE SFP ports 17-32 | 5. Trunk Group 3A - 40 GbE QSFP ports 49-50 |
| 3. Trunk Group 3 - 1/10 GbE SFP ports 33-40 | 6. Trunk Group 4A - 40 GbE QSFP ports 51-52 |

FIGURE 13 Port groups of the VDX 6740T

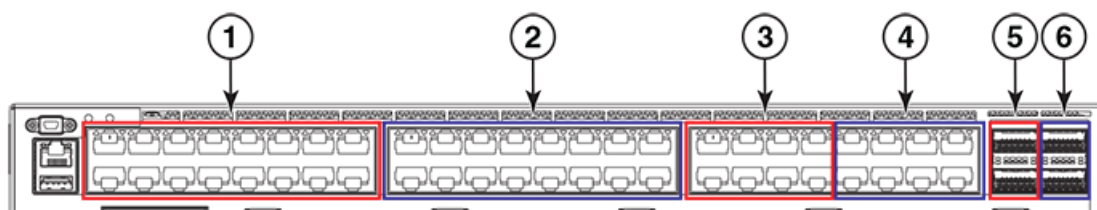

- | | |
|---|---|
| 1. Trunk Group 1 - 1/10 GbE BaseT ports 1-16 | 4. Trunk Group 4 - 1/10 GbE BaseT ports 41-48 |
| 2. Trunk Group 2 - 1/10 GbE BaseT ports 17-32 | 5. Trunk Group 3A - 40 GbE QSFP ports 49-50 |
| 3. Trunk Group 3 - 1/10 GbE BaseT ports 33-40 | 6. Trunk Group 4A - 40 GbE QSFP ports 51-52 |

NOTE

For the VDX 6740T-1G variant, if you release Dynamic Ports On Demand (DPOD) licenses from any 10GbE ports on a 16-port trunk configured with static 10G speed, reserve back those licenses, then perform the **shutdown** and **no shutdown** commands on all trunk ports, the trunk bandwidth will not restore to the maximum 160 Gbps.

Trunking bandwidth limitations

For the VDX 6740T-1G variant, if you release Dynamic Ports On Demand (DPOD) licenses from any 10GbE ports on a 16-port trunk configured with static 10G speed, reserve back those licenses, then enable the **shutdown** and **no shutdown** commands on all trunk ports, the trunk bandwidth will not restore to the maximum 160 Gbps.

Preparing for the Installation

- Installation and safety considerations.....25
- Items required for the installation.....27
- Items included with the device.....27

Installation and safety considerations

You can install the devices in the following ways:

- As a standalone unit on a flat surface.
- For the ExtremeSwitching VDX 6740 device:
 - In a four-post EIA rack.
 - In a two-post telecommunications (Telco) rack.
- For the ExtremeSwitching VDX 6740T device:
 - In a four-post EIA rack.
 - In a two-post Telco rack.



CAUTION

Make sure the airflow around the front, and back of the device is not restricted.



DANGER

The procedures in this manual are for qualified service personnel.

Power precautions

To install and operate the device successfully, ensure compliance with the following safety requirements:

- The power supply standards provided in "Power Supply Specifications" are met.
- The primary outlets are correctly wired, protected by a circuit breaker, and grounded in accordance with local electrical codes.



DANGER

Connect the power cord only to a grounded outlet.

- The supply circuit, line fusing, and wire size are adequate, as specified by the electrical rating on the device nameplate.
- This device might have more than one power cord. To reduce the risk of electric shock, disconnect both power cords before servicing.



DANGER

Disconnect the power cord from all power sources to completely remove power from the device.



DANGER

This product is designed for an IT power system with phase-to-phase voltage of 230V. After operation of the protective device, the equipment is still under voltage if it is connected to an IT power system.

Environmental precautions

For successful installation and operation of the device, ensure that the following environmental requirements are met:

- Fans supplied with the device move air either front to back (exhaust) or back to front (intake). Be sure to align the device with the airflow pattern of any other devices in the rack. All equipment in the rack should force air in the same direction to avoid intake of exhaust air.



CAUTION

Ensure that the airflow direction of the power supply unit matches that of the installed fan tray. The power supplies and fan trays are clearly labeled with either a green arrow with an "E", or an orange arrow with an "I."

- Ensure that the airflow available at intake vents allows the maximum airflow as specified in the product Technical Specifications.
- Ensure that the ambient air temperature does not exceed that specified for maximum operational temperature in the product Technical Specifications.

EIA rack considerations

For successful installation and operation of the device in a rack, ensure the following rack requirements are met:

- The rack must be a standard EIA rack.
- For 1U devices, the rack space required is one rack unit (1U) 44.45 mm (1.75 in.) high and 440 mm (17.5 in.) wide.
- The equipment in the rack is grounded through a reliable branch circuit connection and maintains ground at all times. Do not rely on a secondary connection to a branch circuit, such as a power strip.
- Ensure that the rack mounting does not impede airflow or negatively affect temperature requirements, particularly if the device is installed in a closed or multirack assembly. Ensure that airflow openings on the port and nonport side of the device are not obstructed.



CAUTION

Make sure the airflow around the front, and back of the device is not restricted.

- The additional weight of the device does not exceed the rack's weight limits or unbalance the rack in any way.
- The rack is secured to ensure stability in case of unexpected movement, such as an earthquake.



DANGER

Make sure the rack housing the device is adequately secured to prevent it from becoming unstable or falling over.

Recommendations for cable management

The minimum radius to which a 50-micron cable can be bent under full tensile load is 5.1 cm (2 in.). For a cable under no tensile load, that minimum is 3.0 cm (1.2 in.).

Cables can be organized and managed in a variety of ways; for example, use cable channels on the sides of the EIA rack or patch panels to reduce the potential for tangling the cables. The following list provides some recommendations for cable management:

NOTE

You should not use tie wraps with optical cables because they are easily overtightened and can damage the optic fibers. Velcro-like wraps are recommended.

- Plan for the rack space required for cable management before installing the device.
- Leave at least 1 m (3.28 ft) of slack for each port cable. This provides room to remove and replace the device, allows for inadvertent movement of the rack, and helps prevent the cables from being bent to less than the minimum bend radius.
- For easier maintenance, label the cables and record the devices to which they are connected.
- Keep LEDs visible by routing port cables and other cables away from the LEDs.

Items required for the installation

The following items are required for installing, configuring, and connecting the device for use in a network and fabric:

- A workstation with an installed terminal emulator, such as HyperTerminal.
- An unused IP address and corresponding subnet mask and gateway address.
- A serial cable (provided).
- An Ethernet cable.
- Power cord (provided).
- (Optional) Access to an FTP server or Extreme-branded USB device for backing up the device configuration.
- (Optional) If mounting in the iDataplex IBM 15.5-inch depth rack, the Extreme Networks iDataplex rack mount kit.

Items included with the device

The following items are included with the standard shipment of a fully-configured VDX 6740. When you open the packaging, verify that the items are included in the package and that no damage has occurred during shipping.

- The VDX 6740 or VDX 6740T chassis.
- Transceivers and cables as ordered
- One accessory kit, containing the following items:
 - Serial cable with an RJ-45 connector (VDX 6740) or a mini-USB connector (VDX 6740T)
 - 6 ft. power cords (2)
 - Rubber feet, required for setting up the device as a standalone unit
 - 2 GB USB drive
 - China RoHS hazardous/toxic substance content chart
 - EULA/Read-Me document
 - Web pointer card for documentation

Mounting the Device

• Mounting options.....	29
• Mounting precautions.....	30
• Standalone installation	30
• Installing the 1U Slim Rail Rack Mount Kit for Four-Post Racks (XBR-000291).....	31
• Installing the 1U, 1.5U, and 2U Universal Kit for Four Post Racks (XBR-R000295).....	35
• Time and items required.....	36
• Parts list.....	36
• Flush-front mounting the device in the rack.....	37
• Flush-rear (recessed) mounting the device in the rack.....	44
• Installing the 1U, 1.5U, and 2U Mid-Mount Kit for Two-Post Racks (XBR-000165, XBR-000175, and XBR-R000292).....	50
• Installing the 1U and 2U Flush-Mount Rack Kit for Two-Post Racks (XBR-000307 and XBR-R000293).....	56
• Installing the Universal Four-Post Rack Kit (XBR-R000296).....	61
• Installing the Universal Two-Post Rack Kit (XBR-R000294).....	74

Mounting options

You can mount the ExtremeSwitching VDX 6740 device in the following locations:

- As a standalone unit on a flat surface, for example, a table top. Use the rubber feet included with the shipment to secure the device on the surface. No other equipment is required for desktop installation.
- In a four-post EIA rack:
 - Use the 1U Slim Rail Rack Mount Kit for Four-Post Racks (XBR-000291). Follow instructions in [Installing the 1U Slim Rail Rack Mount Kit for Four-Post Racks \(XBR-000291\)](#) on page 31.
- In a two-post Telco rack:
 - Use the 1U, 1.5U, and 2U Mid-Mount Kit for Two-Post Racks (XBR-R000292). Follow instructions in [Installing the 1U, 1.5U, and 2U Mid-Mount Kit for Two-Post Racks \(XBR-000165, XBR-000175, and XBR-R000292\)](#) on page 50.
 - Use the 1U and 2U Flush-Mount Rack Kit for Two-Post Racks (XBR-000293). Follow instructions in [Installing the 1U and 2U Flush-Mount Rack Kit for Two-Post Racks \(XBR-000307 and XBR-R000293\)](#) on page 56.

You can mount the ExtremeSwitching VDX 6740T device in the following locations:

- As a standalone unit on a flat surface, for example, a table top. Use the rubber feet included with the shipment to secure the device on the surface. No other equipment is required for desktop installation.
- Use the 1U, 1.5U, and 2U Universal Rack Mount Kit for Four Post Racks (XBR-R000295). Follow instructions in [Installing the 1U, 1.5U, and 2U Universal Kit for Four Post Racks \(XBR-R000295\)](#) on page 35.
- In a four-post EIA rack. Use the Universal Four-Post Rack Kit (XBR-R000296). Follow instructions in [Installing the Universal Four-Post Rack Kit \(XBR-R000296\)](#) on page 61.
- In a two-post Telco rack. Use the Universal Two-Post Rack Kit (XBR-R000294). Follow instructions in [Installing the Universal Two-Post Rack Kit \(XBR-R000294\)](#) on page 74.

NOTE

Review the [Mounting precautions](#) on page 30 before mounting the device and ensure that you have considered all precautions in [Installation and safety considerations](#) on page 25.

NOTE

Rack mount kits described in this document are those supported at the time of publication. For the latest support information, contact your Extreme Networks representative.

Mounting precautions

The following precautions specifically apply to mounting the device.



DANGER

Use safe lifting practices when moving the product.



DANGER

Mount the devices you install in a rack as low as possible. Place the heaviest device at the bottom and progressively place lighter devices above.



CAUTION

Make sure the airflow around the front, and back of the device is not restricted.



CAUTION

Use the screws specified in the procedure. Using longer screws can damage the device.



CAUTION

To prevent damage to the chassis and components, never attempt to lift the chassis using the fan or power supply handles. These handles were not designed to support the weight of the chassis.

Refer to the "EIA rack considerations" in [Installation and safety considerations](#) on page 25.

Standalone installation

Complete the following steps to install the device as a standalone unit on a table top.

1. Unpack the device and verify the items listed under "Items included with this device" are present and undamaged.
2. Apply the adhesive rubber feet to the device. The rubber feet help prevent the device from sliding off the supporting surface.
 - a) Clean the indentations at each corner of the bottom of the device to ensure that they are free of dust or other debris that might lessen the adhesion of the feet.
 - b) With the adhesive side against the chassis, place one rubber foot in each indentation and press into place.
3. Place the device on a flat, sturdy surface.
4. Provide power to the device as described under "Providing power to the device."

NOTE

Do not connect the device to the network until the IP address is correctly set. For instructions on how to set the IP address, refer to "Configuring the device IP address."

Installing the 1U Slim Rail Rack Mount Kit for Four-Post Racks (XBR-000291)

Use the following instructions to install a fixed-port device in a slim rail four-post configuration using the Slim Rail Rack Mount Kit for Four-Post Racks (XBR-000291).

Observe the following when mounting this device:

- Two people are required to install the device in a rack. One person holds the device, while the other screws in the front and rear brackets.
- Use Electronic Industries Association (EIA) standard racks.
- Before mounting your device, review any specific installation and facility requirements in this Hardware Installation Guide.
- Hardware devices illustrated in these procedures are only for reference and may not depict the device you are installing into the rack.

Time and items required

Allow 15 to 30 minutes to complete this procedure.

Allow approximately one hour to unpack and install the device in a rack.

The following items are required to install a device using the slimline fixed rack mount kit:

- Phillips #2 screwdriver with torque capability.
- 1/4 in. slotted-blade screwdriver with torque capability.

NOTE

You may need two people to install the device, one to support the device, while the other secures it into the rack.



CAUTION

The device must be turned off and disconnected from the fabric during this procedure.

Parts List

The following parts are provided with the 1U Slim Rail Rack Mount Kit for Four-Post Racks (XBR-000291).

FIGURE 14 Rack kit parts

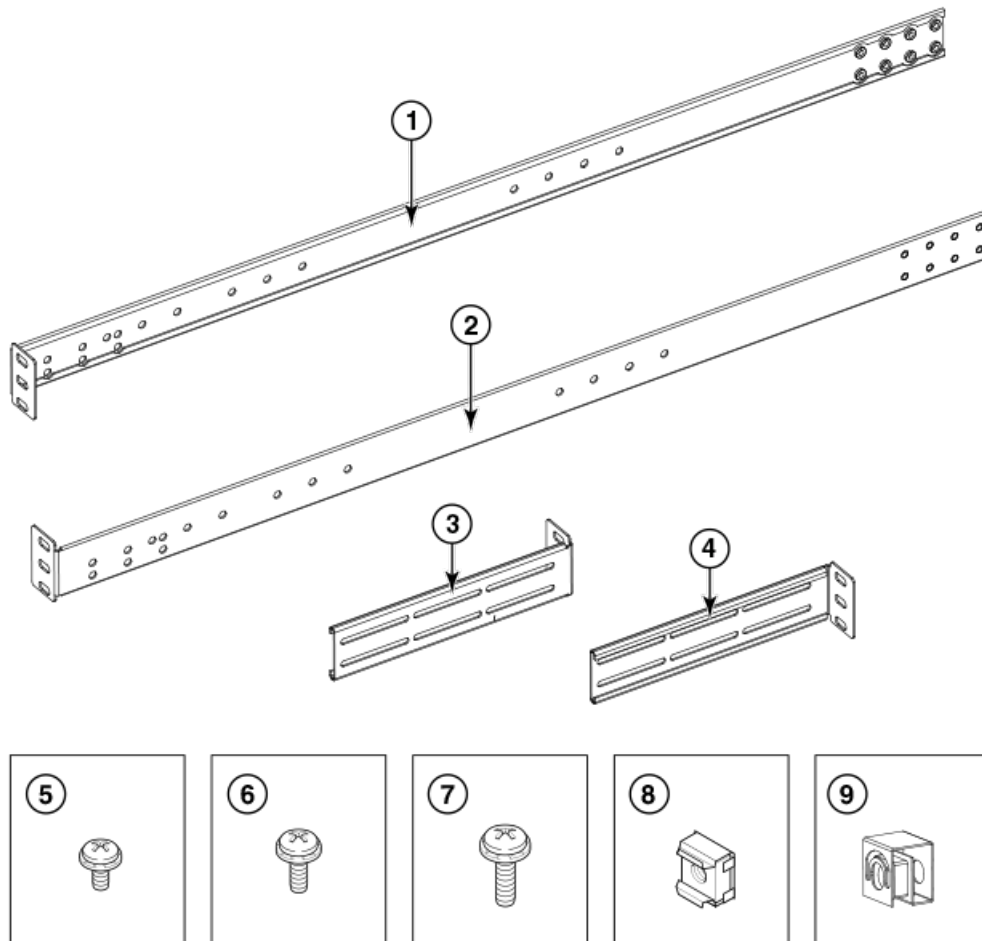

- | | |
|--|--|
| <ul style="list-style-type: none"> 1. Bracket, front right (1) 2. Bracket, front left (1) 3. Bracket, rear left (1) 4. Bracket, rear right (1) 5. Screw, 8-32 x 5/16 in., panhead Phillips (10) | <ul style="list-style-type: none"> 6. Screw, 6-32 x 1/4 in., panhead Phillips (8) 7. Screw, 10-32 x 5/8 in., panhead Phillips (8) 8. Retainer nut, 10-32, (for square-hole rack rails) (8) 9. Retainer nut, 10-32, (for round-hole rack rails) (8) |
|--|--|

NOTE

Not all parts may be used with certain installations depending on the device type.



CAUTION

Use the screws specified in the procedure. Using longer screws can damage the device.

Attaching the front brackets

Complete the following steps to attach the front brackets to the device.

NOTE

Hardware devices illustrated in these procedures are only for reference and may not depict the device you are installing into the rack.

1. Position the right front bracket with the flat side against the right side of the device as shown in the following figure.
2. Insert two 8-32 x 5/16 in. screws into one of the pairs of vertically aligned holes in the bracket and then into the pair of holes on the side of the device. There are three pairs of vertically aligned holes in the brackets. To install the device flush to the front of the rack, use the pair of holes at the front of the bracket. To install the device in a recessed position in the rack, use one of the other two pairs of bracket holes that are set back from the end of the bracket.
3. Insert each 8-32 x 5/16 in. screw through the holes in the bracket and into the corresponding hole in the device and tighten all 8-32 x 5/16 in. screws to a torque of 15 in-lb (17 cm-kg).
4. Repeat step 1 through step 3 to attach the left front bracket to the left side of the device.

FIGURE 15 Position the front bracket

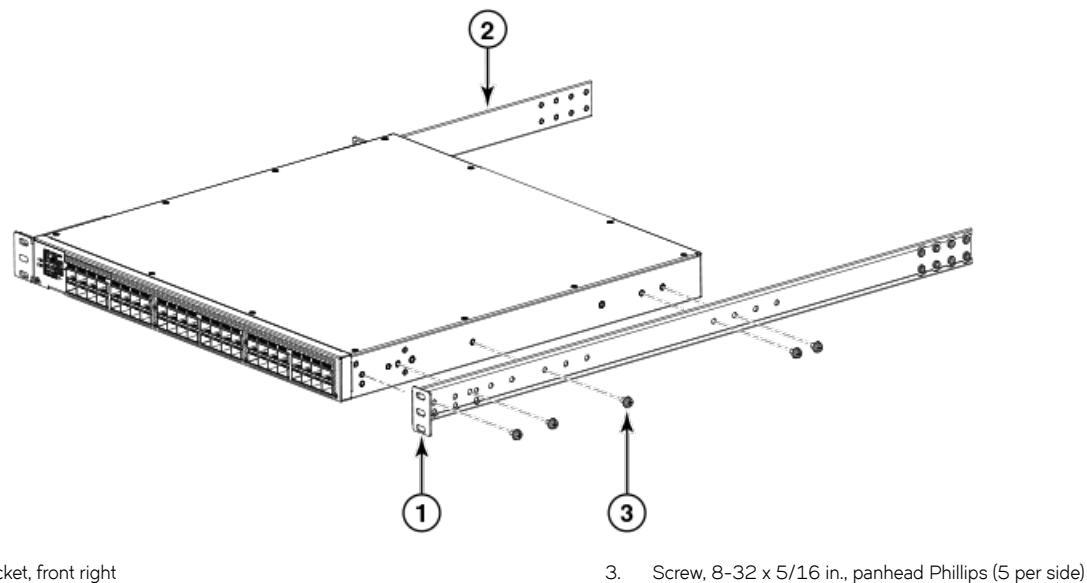

1. Bracket, front right
2. Bracket, front left

3. Screw, 8-32 x 5/16 in., panhead Phillips (5 per side)

NOTE

Ensure that the device is oriented properly with the air-intake aisle. The power supply and fan FRU airflow must be the same to prevent overheating. If both FRUs have the Intake (I) label or no label, orient the device with the fan facing the air-intake aisle. If both FRUs have the Exhaust (E) label, orient the port side of the device to face the air-intake aisle.

Installing the device in the rack

The rails in the Slim Rail Rack Mount Kit (XBR-R000291) have been specially designed for the following devices. Because this device is slightly wider than other devices, the rails are narrower to account for the additional width. Do not attempt to mount the device with standard rail kits.

- ExtremeSwitching 6510
- ExtremeSwitching 6505
- ExtremeSwitching VDX 6740



CAUTION

The device must be turned off and disconnected from the fabric during this procedure.

Complete the following steps to install the device in the rack.

NOTE

Hardware devices illustrated in these procedures are only for reference and may not depict the device you are installing into the rack.

1. Position the device in the rack as shown in the following figure, providing temporary support under the device until the rail kit is secured to the rack.
2. Attach the right front bracket to the right front rack post using two 10-32 x 5/8 in. screws and two retainer nuts.
3. Repeat step 2 to attach the left front bracket to the left front rack post and tighten all 10-32 x 5/8 in. screws to a torque of 25 in-lb (29 cm-kg).

FIGURE 16 Position the device in the rack

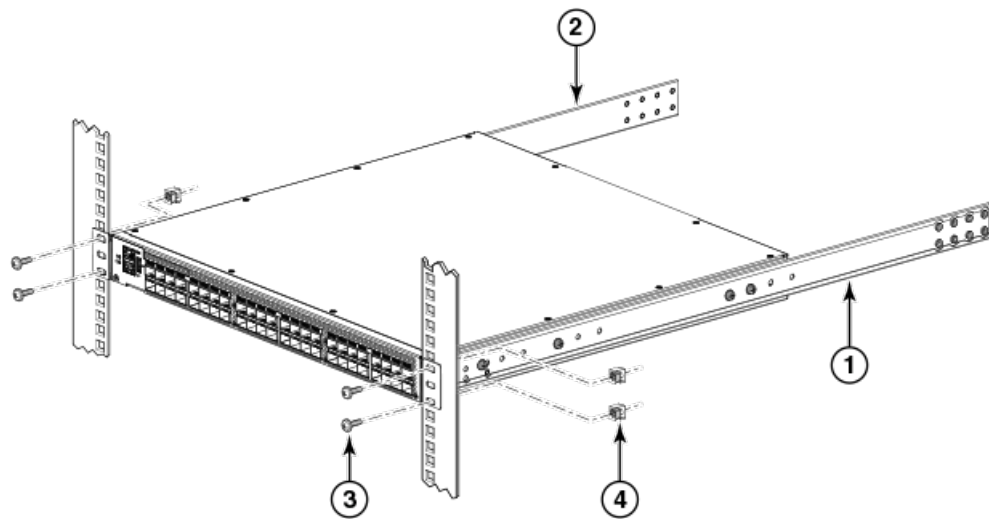

1. Bracket, front right
2. Bracket, front left

3. Screw, 10-32 x 5/8 in., panhead Phillips
4. Retainer nut, 10-32, square or round hole as needed

Attaching the rear brackets to the front brackets

Complete the following steps to attach the rear brackets to the front brackets.

NOTE

Hardware devices illustrated in these procedures are only for reference and may not depict the device you are installing into the rack.

1. Position the right rear bracket inside the right front bracket as shown in the following figure.
2. Attach the brackets using four 6-32 x 1/4 in. screws.
3. Adjust the brackets to rack depth and tighten the screws to a torque of 9 in-lb (10 cm-kg).

- Repeat step 1 through step 3 to attach the left rear bracket to the left front bracket.

FIGURE 17 Position the rear and front brackets

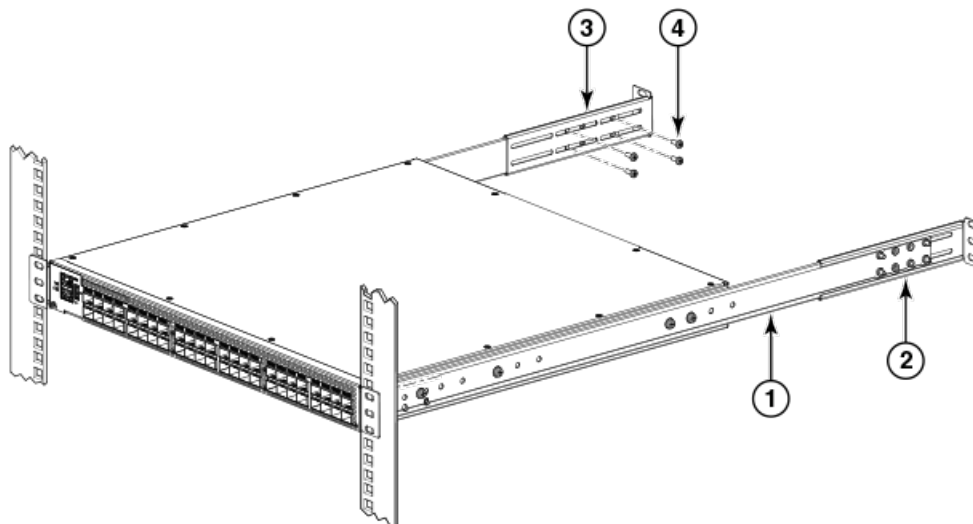

- | | |
|---|--|
| <ol style="list-style-type: none"> Bracket, front right Bracket, rear right | <ol style="list-style-type: none"> Bracket, rear left Screw, 6-32 x 1/4 in., panhead Phillips (four per bracket) |
|---|--|

Attaching the rear brackets to the rack rails

Complete the following steps to attach the rear brackets to the rack rails.

- Attach the right rear bracket to the right rear rack rail using two 10-32 x 5/8 in. screws and two retainer nuts as shown in the following figure.
- Repeat step 1 to attach the left rear bracket to the left rear rack rail and tighten all the 10-32 x 5/8 in. screws to a torque of 25 in-lb (29 cm-kg).
- Provide power to the device by connecting the power cords to the power connectors on the device and a power outlet. Some devices require you to flip a power device to be powered on.

Installing the 1U, 1.5U, and 2U Universal Kit for Four Post Racks (XBR-R000295)

Use the following instructions to install a device in a 19-in. (48.3 cm) EIA rack using the 1U, 1.5U, and 2U Universal Kit for Four Post Racks (XBR-R000295).

Observe the following when mounting this device:

- The device can be installed so that the port side is either flush with the front posts or recessed with the non-port side flush with the rear posts. A recessed position allows a more gradual bend in the fiber-optic cables connected to the device and less interference in the aisle at the front of the rack.

- Use Electronic Industries Association (EIA) standard racks. Provide space in a 19-in. (48.3 cm) EIA rack, as required for the device, with a minimum distance of 24 in. (609.60 mm) and a maximum distance of 32 in. (812.80 mm) between the front and back posts.
- Two people are required to install the device in a rack. One person should hold the device, while the other while the other secures the device in the rack.
- Before mounting your device, review any specific installation and facility requirements in this Hardware Installation Guide.
- Hardware devices illustrated in these procedures are only for reference and may not depict the device you are installing into the rack.

Time and items required

Allow 15 to 30 minutes to complete this procedure. Note the following requirements to ensure correct installation and operation.

The following items are required to install the device using the 1U, 1.5U, and 2U Universal Kit for Four-Post Racks:

- #2 Phillips torque screwdriver
- 1/4-inch slotted-blade torque screwdriver

Parts list

The following parts are provided with the 1U, 1.5U, and 2U Universal Kit for Four Post Racks Installation (XBR-R000295).

FIGURE 18 Rack kit parts

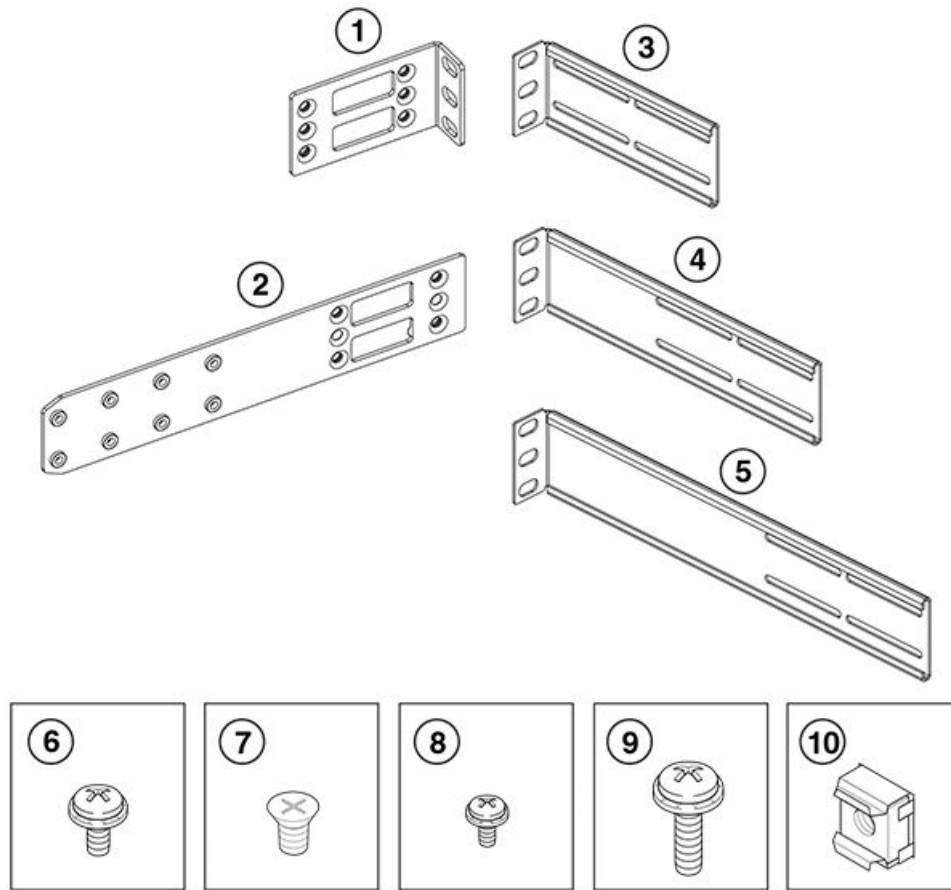

- | | |
|------------------------------|---|
| 1. Front brackets (2) | 6. Screw, 8-32 x 5/16-in., panhead Phillips (8) |
| 2. Bracket extensions (2) | 7. Screw, 8-32 x 5/16-in., flathead Phillips (16) |
| 3. Rear brackets, short (2) | 8. Screw, 6-32 x 1/4-in., panhead Phillips (8) |
| 4. Rear brackets, medium (2) | 9. Screw, 10-32 x 5/8-in., panhead Phillips (8) |
| 5. Rear brackets, long (2) | 10. Retainer nut, 10-32 (8) |

Ensure that the items listed and illustrated are included in the kit. Note that not all parts may be used with certain installations depending on the device type.



CAUTION

Use the screws specified in the procedure. Using longer screws can damage the device.

Flush-front mounting the device in the rack



CAUTION

The device must be turned off and disconnected from the fabric during this procedure.

NOTE

Illustrations in these rack installation procedures are for reference only and may not show the actual device that you are installing.

Complete the following tasks to install the device in a four-post rack:

1. [Attaching the front brackets](#) on page 38
2. [Attaching the bracket extensions to the device](#) on page 39
3. [Installing the device in the rack](#) on page 40
4. [Attaching the rear brackets to the extensions](#) on page 41
5. [Attaching the rear brackets to the rack posts](#) on page 43

Attaching the front brackets

Complete the following steps to attach the front brackets to the device.

1. Position the right front bracket with the flat side against the right side of the device at the front of the device, as shown in [Figure 19](#).
2. Insert four 8-32 x 5/16-in. flathead screws through the vertically aligned holes in the bracket and then into the holes on the side of the device. Use the upper and lower screw holes, leaving the center holes empty.
3. Repeat Step 1 and Step 2 to attach the left front bracket to the left side of the device.

4. Tighten all the 8-32 x 5/16-in. screws to a torque of 15 in-lb (17 cm-kg).

FIGURE 19 Attaching the front brackets

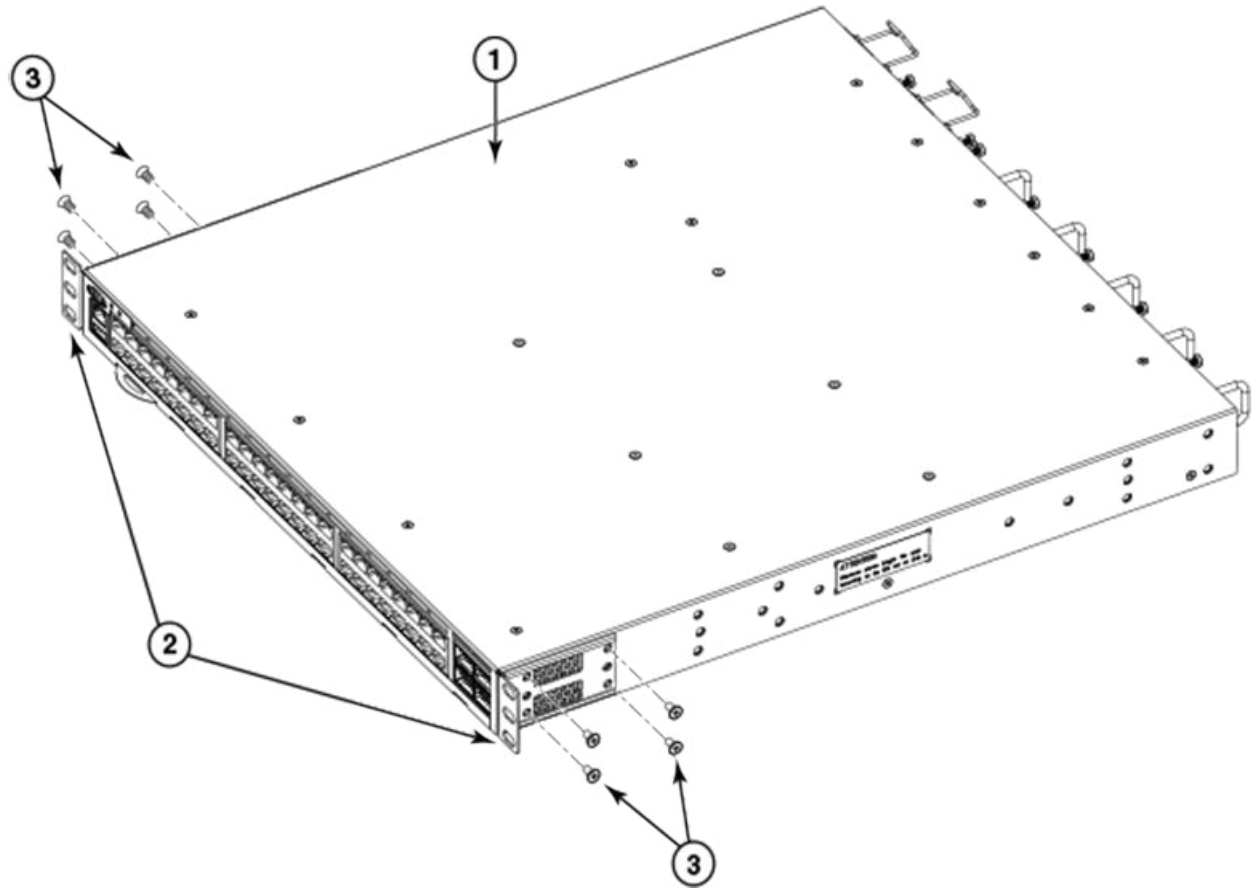

1. The device
2. Front brackets

3. Screws, 8-32 x 5/16-in., flathead Phillips

Attaching the bracket extensions to the device

Complete the following steps to attach the extension brackets to the device.

1. Position the right bracket extension along the side of the device as shown in [Figure 20](#).
2. Insert four 8-32 x 5/16-in. flathead screws through the vertically aligned holes in the bracket extension and then into the holes on the side of the device. Use the upper and lower screw holes, leaving the center holes empty.
3. Repeat step 1 and step 2 to attach the left bracket extension to the left side of the device.

4. Tighten all the 8-32 x 5/16-in. screws to a torque of 15 in-lb (17 cm-kg).

FIGURE 20 Attaching the bracket extensions to the device

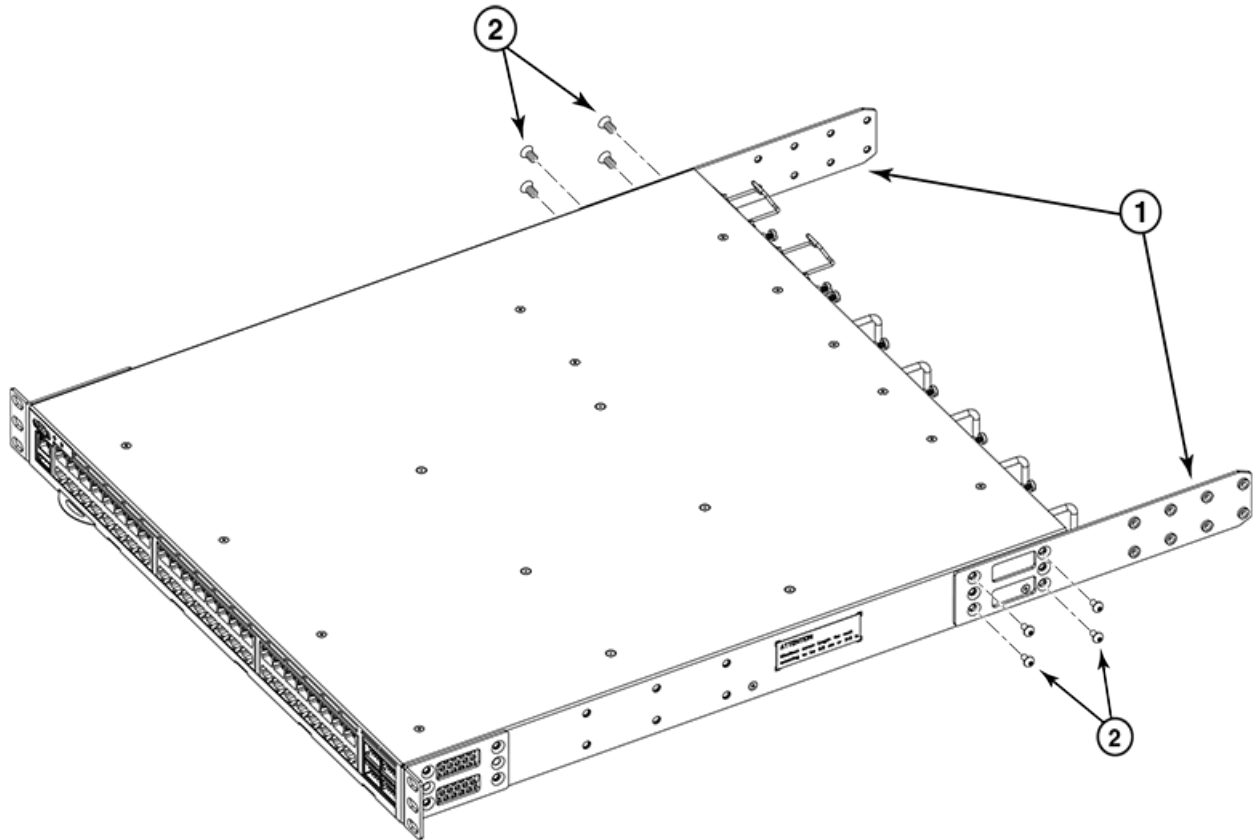

1. Bracket extensions

2. Screws, 8-32 x 5/16-in., flathead Phillips

Installing the device in the rack

Complete the following steps to install the device in the rack.

1. Position the device in the rack, as shown in [Figure 21](#), providing temporary support under the device until the rail kit is secured to the rack.
2. Attach the right front bracket to the right front rack post using two 10-32 x 5/8-in. panhead screws and two retainer nuts. Use the upper and lower holes in the bracket.
3. Attach the left front bracket to the left front rack post using two 10-32 x 5/8-in. panhead screws and two retainer nuts. Use the upper and lower holes in the bracket.

4. Tighten all the 10-32 x 5/8-in. screws to a torque of 25 in-lb (29 cm-kg).

FIGURE 21 Positioning the device in the rack

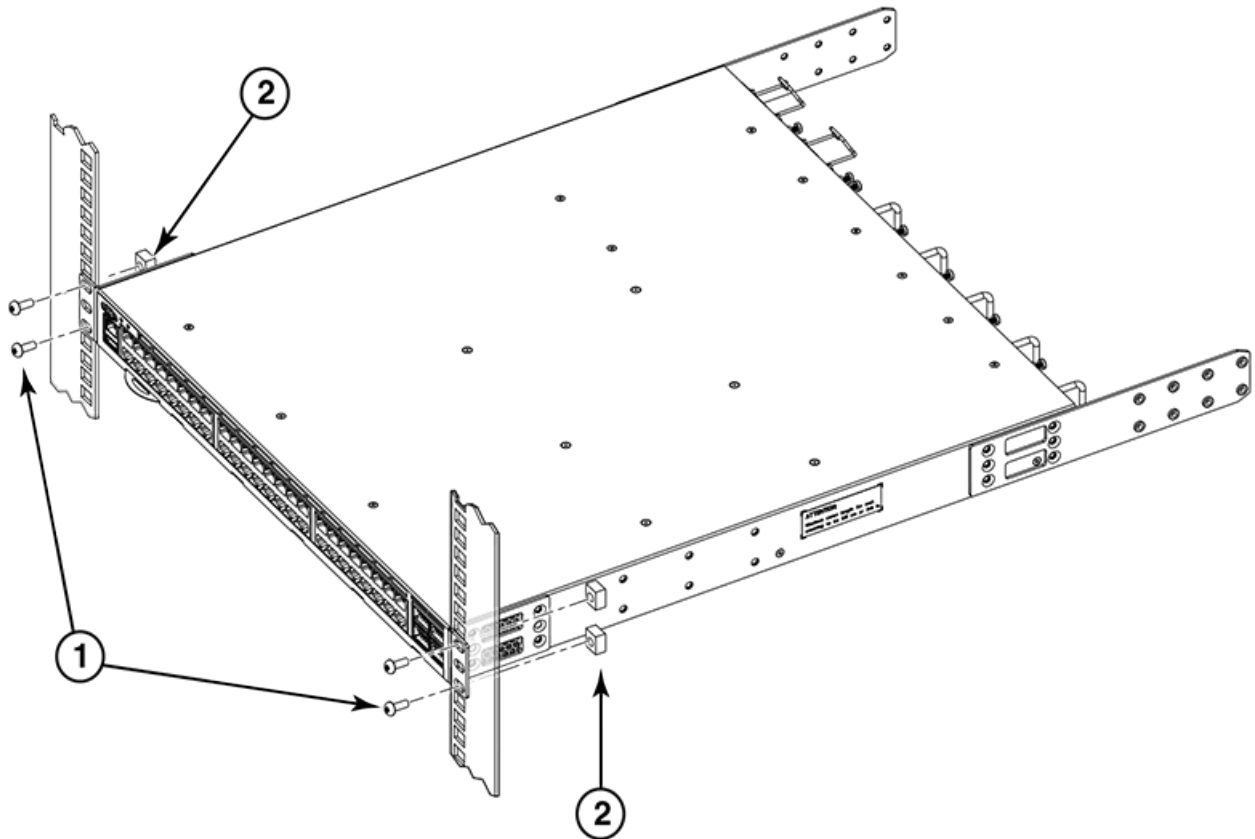

1. Screws, 10-32 x 5/8-in., panhead Phillips

2. Retainer nuts, 10-32

Attaching the rear brackets to the extensions

Complete the following steps to attach the rear brackets to the extensions. There are short, medium, and long rear brackets that you can use for this step. Choose the correct bracket for the depth of your rack.

1. Select the proper length rear bracket for your rack depth.
2. Slide the right rear bracket onto the right extension, as shown in [Figure 22](#).
The short rear brackets are shown. Use the first and third vertical pairs of holes for the screws.
Refer to [Figure 23](#) for the positioning of the medium or long brackets and screws.
3. Attach the brackets using four 6-32 x 1/4-in. panhead screws.
4. Repeat [Step 2](#) and [Step 3](#) to attach the left rear bracket to the left extension.

- Adjust the brackets to the rack depth and tighten all the 6-32 x 1/4-in. screws to a torque of 9 in-lb (10 cm-kg).

FIGURE 22 Attaching the short rear brackets to the extensions

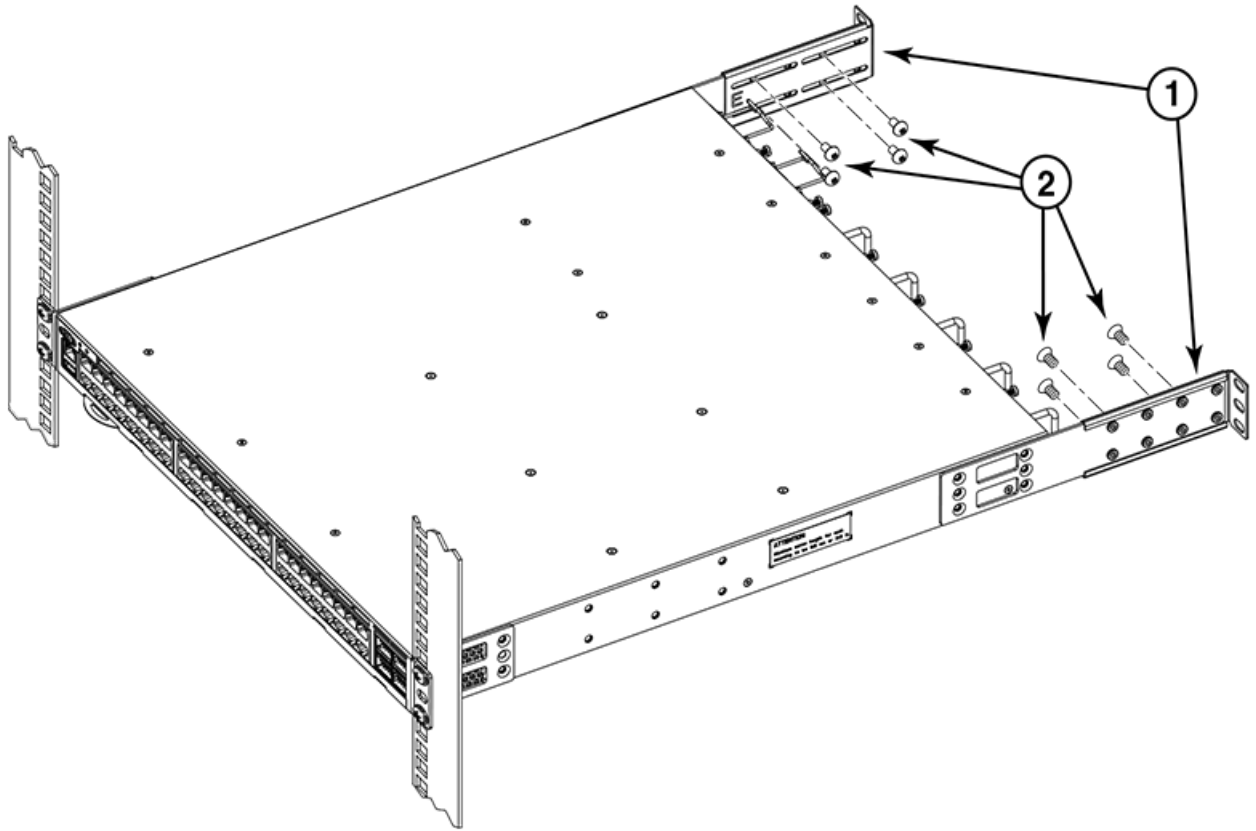

1. Rear brackets

2. Screws, 6-32 x 1/4-in., panhead Phillips

FIGURE 23 Attaching the medium or long rear brackets to the extensions

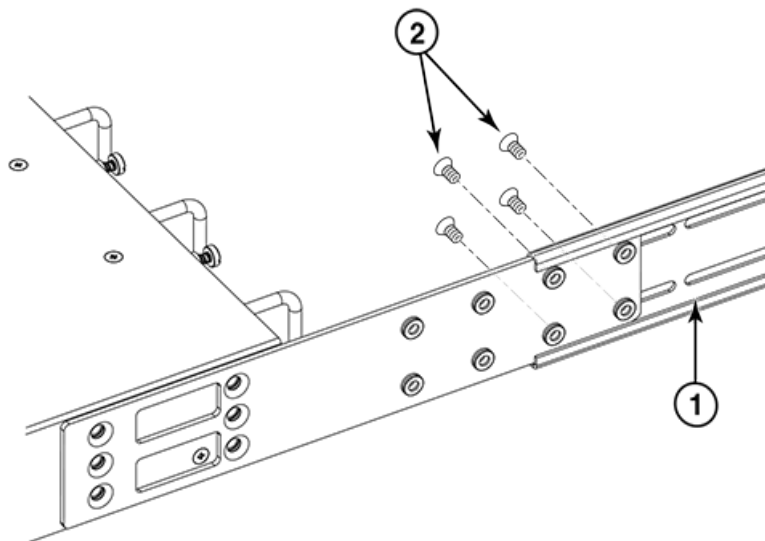

1. Rear bracket, medium or long
2. Screws, 6-32 x 1/4-in., panhead Phillips

Attaching the rear brackets to the rack posts

Complete the following steps to attach the rear brackets to the rack posts.

1. Attach the right rear bracket to the right rear rack post using two 10-32 x 5/8-in. panhead screws and two retainer nuts, as shown in [Figure 24](#). Use the upper and lower holes in the bracket.
2. Attach the left rear bracket to the left rear rack post using two 10-32 x 5/8-in. panhead screws and two retainer nuts. Use the upper and lower holes in the bracket.
3. Tighten all the 10-32 x 5/8-in. screws to a torque of 25 in-lb (29 cm-kg).

FIGURE 24 Attaching the rear brackets to the rack posts

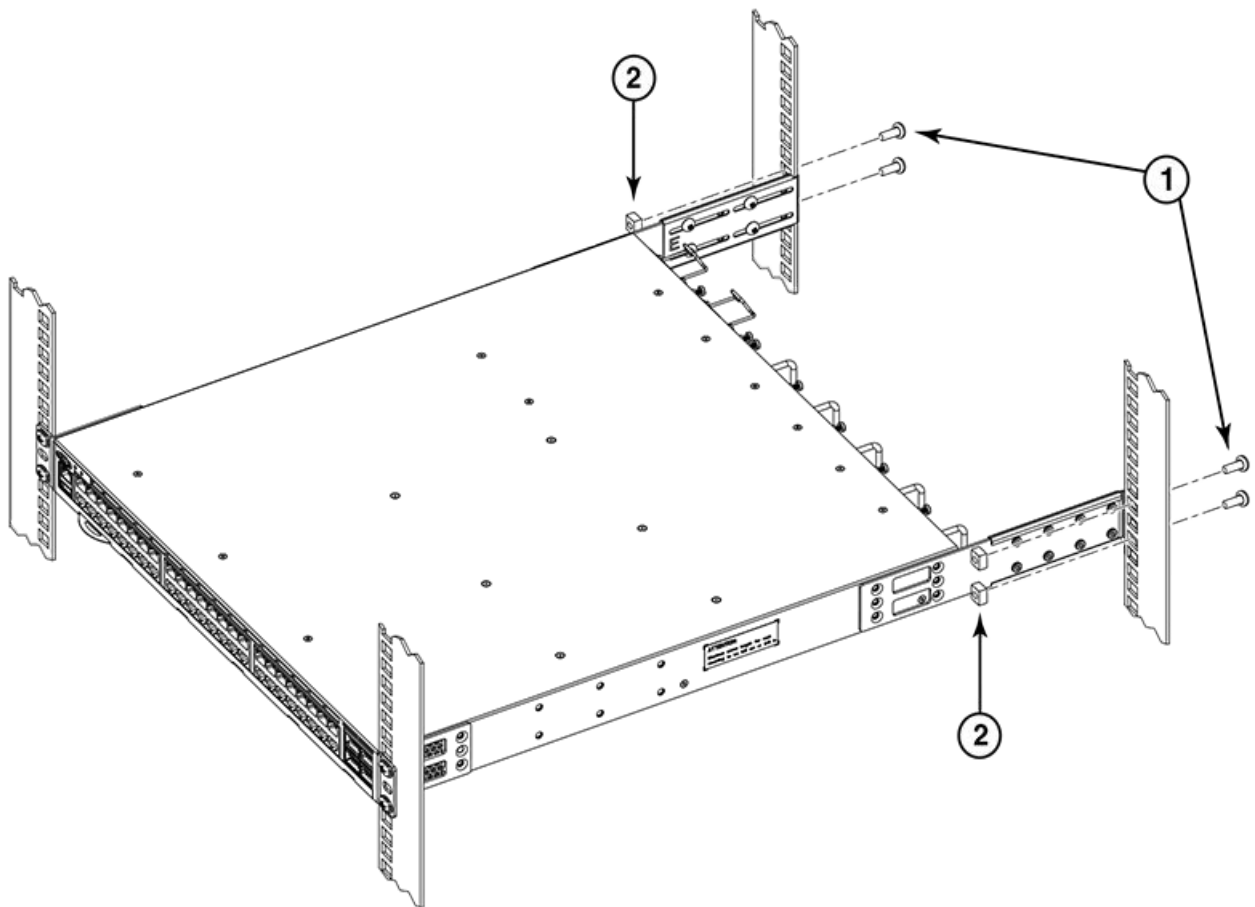

1. Screws, 10-32 x 5/8-in., panhead Phillips

2. Retainer nuts, 10-32

Flush-rear (recessed) mounting the device in the rack

The flush-rear (recessed) mounting is similar to the flush-front mounting except that the brackets are reversed on the device.



CAUTION

The device must be turned off and disconnected from the fabric during this procedure.

NOTE

Illustrations used in these rack installation procedures are for reference only and may not show the actual device that you are installing.

Complete the following tasks to install the device in a four-post rack:

1. [Attaching the front brackets to the rear of the device](#) on page 44
2. [Attaching the bracket extensions to the front of the device](#) on page 45
3. [Installing the device in the rack](#) on page 46
4. [Attaching the rear brackets to the bracket extensions at the front of the device](#) on page 47
5. [Attaching the rear brackets to the front rack posts](#) on page 49

Attaching the front brackets to the rear of the device

NOTE

In this installation, the brackets are named as listed in the parts list even though the installation of the brackets is reversed from the flush-front installation.

Complete the following steps to attach the front brackets to the rear of the device.

1. Position the right front bracket with the flat side against the right rear side of the device, as shown in [Figure 25](#).
2. Insert four 8-32 x 5/16-in. flathead screws through the vertically aligned holes in the bracket and then into the holes on the side of the device. Use the upper and lower screw holes, leaving the center holes empty.
3. Repeat [Step 1](#) and [Step 2](#) to attach the left front bracket to the left rear side of the device.

4. Tighten all the 8-32 x 5/16-in. screws to a torque of 15 in-lb (17 cm-kg).

FIGURE 25 Attaching the front brackets to the rear of the device

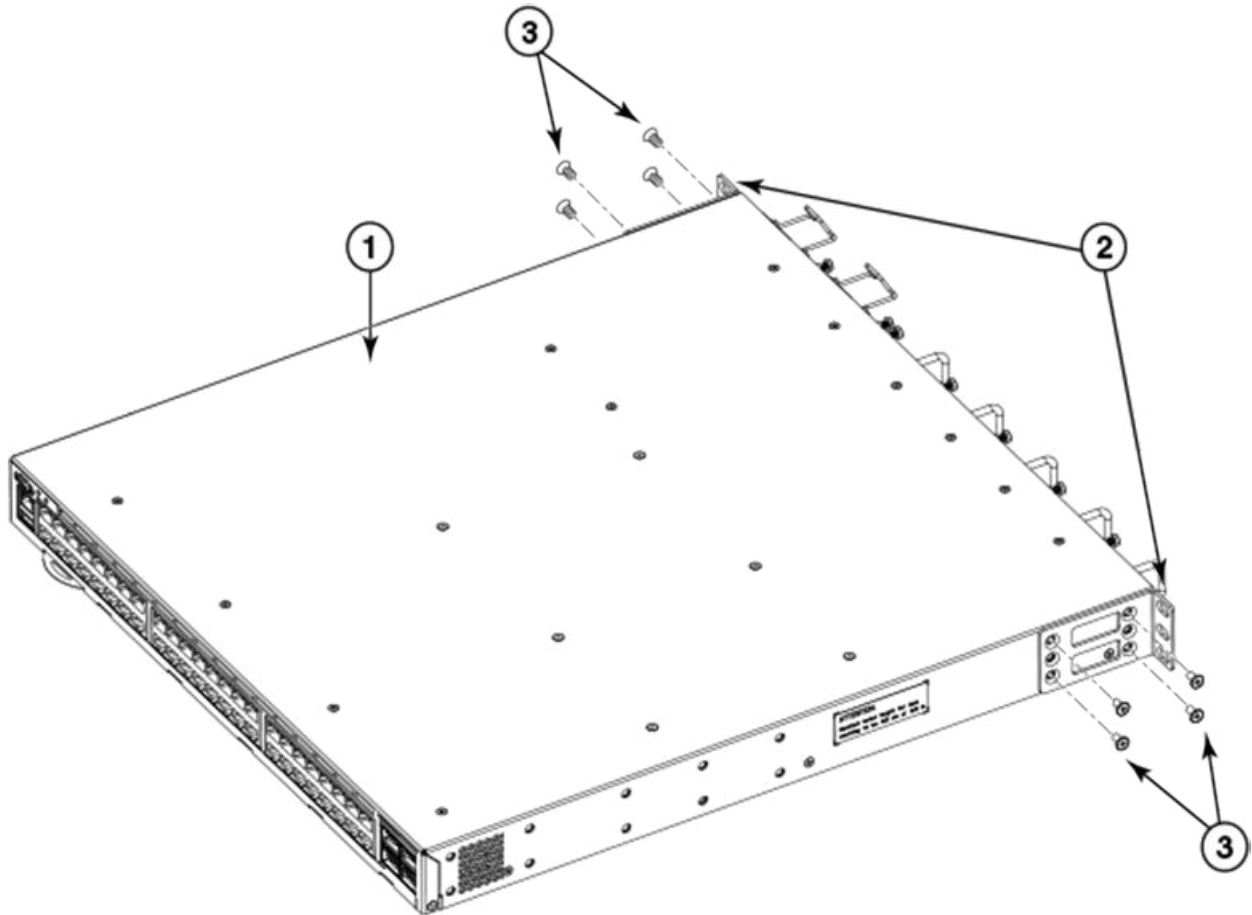

1. The device
2. Front brackets

3. Screws, 8-32 x 5/16-in., flathead Phillips

Attaching the bracket extensions to the front of the device

Complete the following steps to attach the bracket extensions to the front of the device.

1. Position the right bracket extension along the side of the device as shown in [Figure 26](#).
2. Insert four 8-32 x 5/16-in. flathead screws through the vertically aligned holes in the bracket extension and then into the holes on the side of the device. Use the upper and lower screw holes, leaving the center holes empty.
3. Repeat step 1 and step 2 to attach the left front bracket extension to the left side of the device.

4. Tighten all the 8-32 x 5/16-in. screws to a torque of 15 in-lb (17 cm-kg).

FIGURE 26 Attaching the bracket extensions to the device

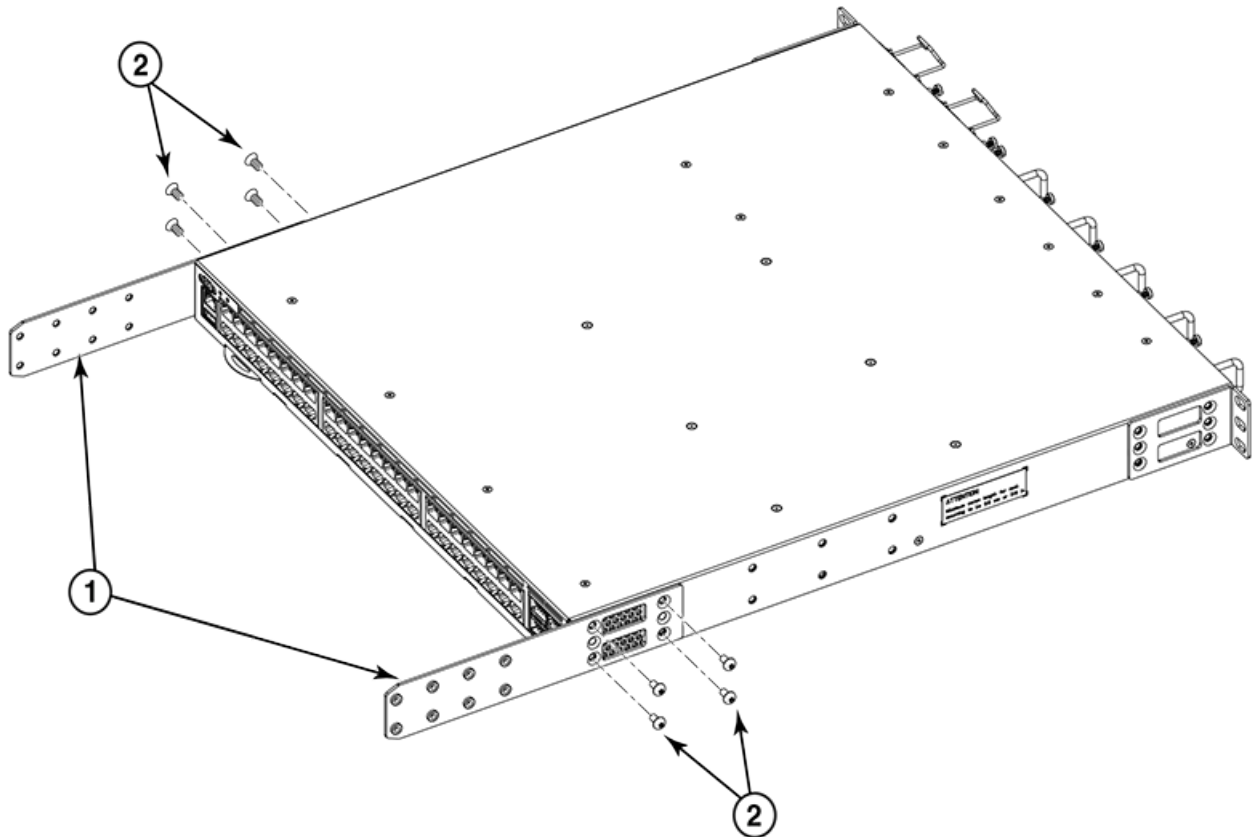

1. Bracket extensions

2. Screws, 8-32 x 5/16-in., flathead Phillips

Installing the device in the rack

Complete the following steps to install the device in the rack.

1. Position the device in the rack, as shown in [Figure 27](#), providing temporary support under the device until the rail kit is secured to the rack.
2. Attach the right front bracket to the right rear rack post using two 10-32 x 5/8-in. panhead screws and two retainer nuts. Use the upper and lower holes in the bracket.
3. Attach the left front bracket to the left rear rack post using two 10-32 x 5/8-in. panhead screws and two retainer nuts. Use the upper and lower holes in the bracket.

4. Tighten all the 10-32 x 5/8-in. screws to a torque of 25 in-lb (29 cm-kg).

FIGURE 27 Positioning the device in the rack

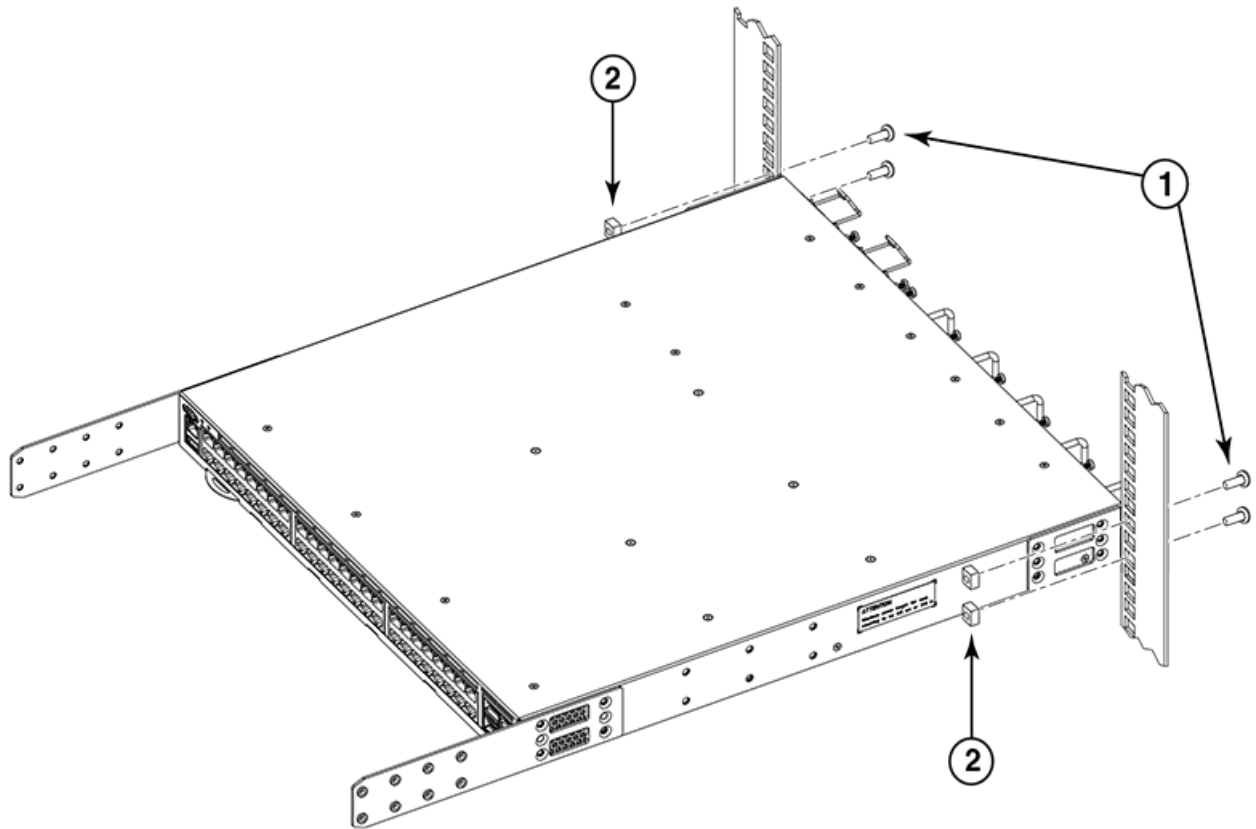

1. Screws, 10-32 x 5/8-in., panhead Phillips

2. Retainer nuts, 10-32

Attaching the rear brackets to the bracket extensions at the front of the device

Complete the following steps to attach the rear brackets to the bracket extensions. There are short, medium, and long front brackets that you can use for this step.

1. Select the proper length rear bracket for your rack depth.
2. Slide the right rear bracket onto the right extension, as shown in [Figure 28](#).

The short rear brackets are shown. Use the first and third vertical pairs of holes for the screws.

Refer to [Figure 29](#) for the positioning of the medium or long brackets and screws.

3. Attach the brackets using four 6-32 x 1/4-in. panhead screws.
4. Repeat [Step 2](#) and [Step 3](#) to attach the left rear bracket to the left extension.

- Adjust the brackets to the rack depth and tighten all the 6-32 x 1/4-in. screws to a torque of 9 in-lb (10 cm-kg).

FIGURE 28 Attaching the short rear brackets to the extensions at the front of the device

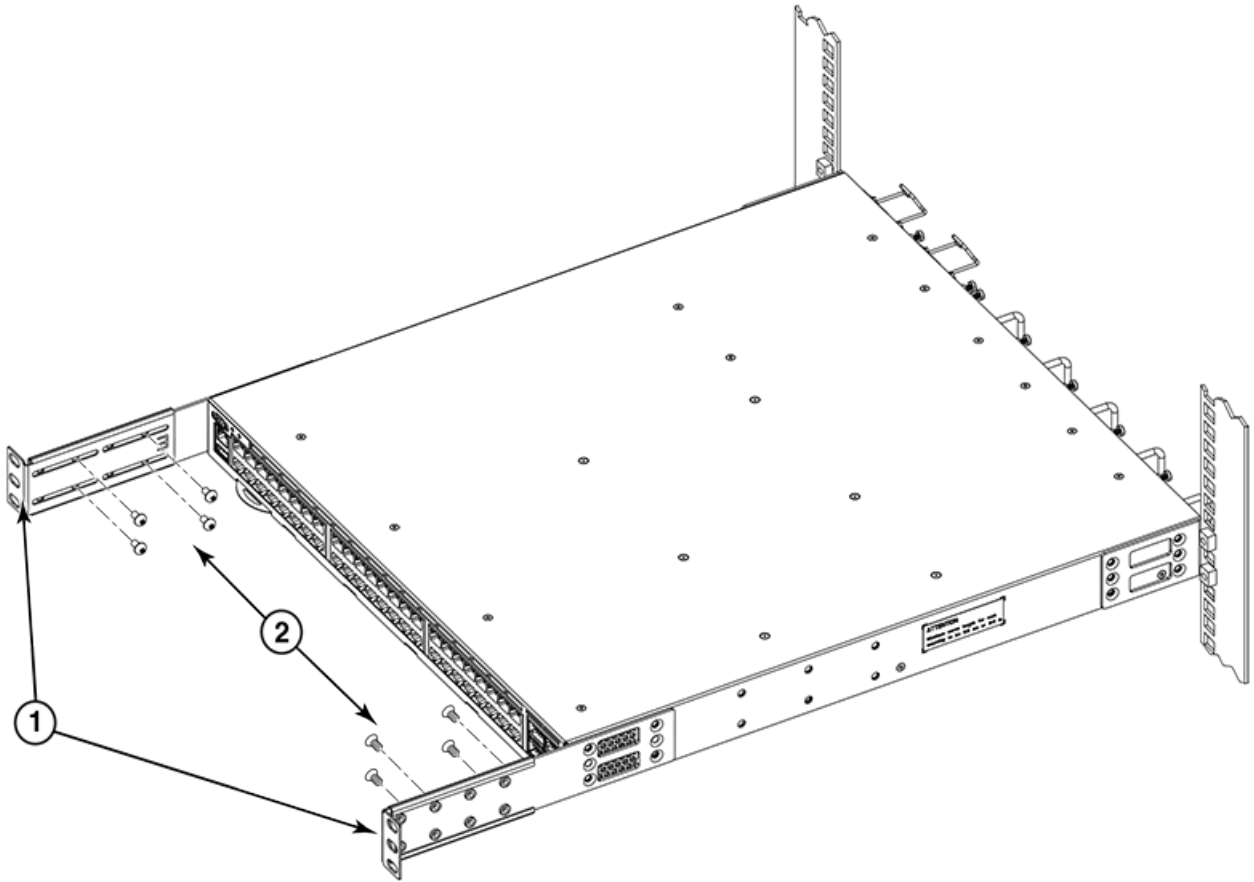

1. Rear brackets, short

2. Screws, 6-32 x 1/4-in., panhead Phillips

FIGURE 29 Attaching the medium or long rear brackets to the extensions

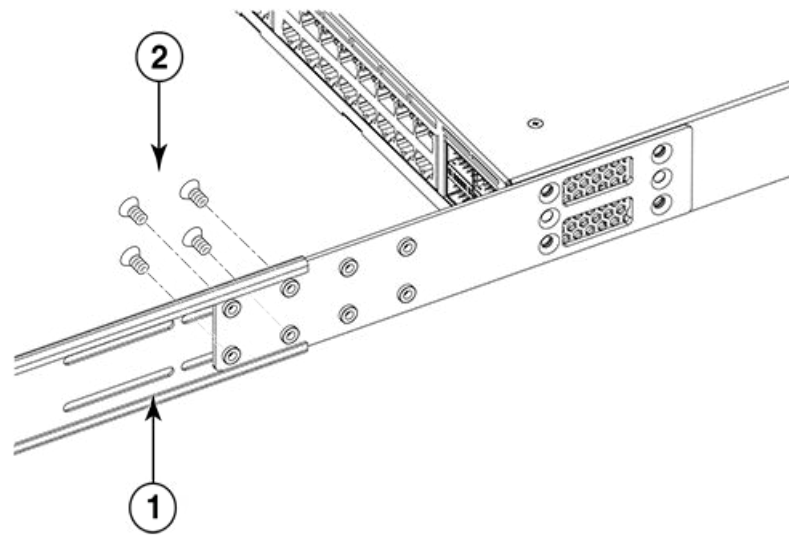

1. Rear bracket, medium or long

2. Screws, 6-32 x 1/4-in., panhead Phillips

Attaching the rear brackets to the front rack posts

Complete the following steps to attach the rear brackets to the front rack posts.

1. Attach the right rear bracket to the right front rack post using two 10-32 x 5/8-in. screws and two retainer nuts, as shown in [Figure 30](#). Use the upper and lower holes in the bracket.
2. Attach the left rear bracket to the left front rack post using two 10-32 x 5/8-in. screws and two retainer nuts. Use the upper and lower holes in the bracket.

3. Tighten all the 10-32 x 5/8-in. screws to a torque of 25 in-lb (29 cm-kg).

FIGURE 30 Attaching the rear brackets to the front rack posts

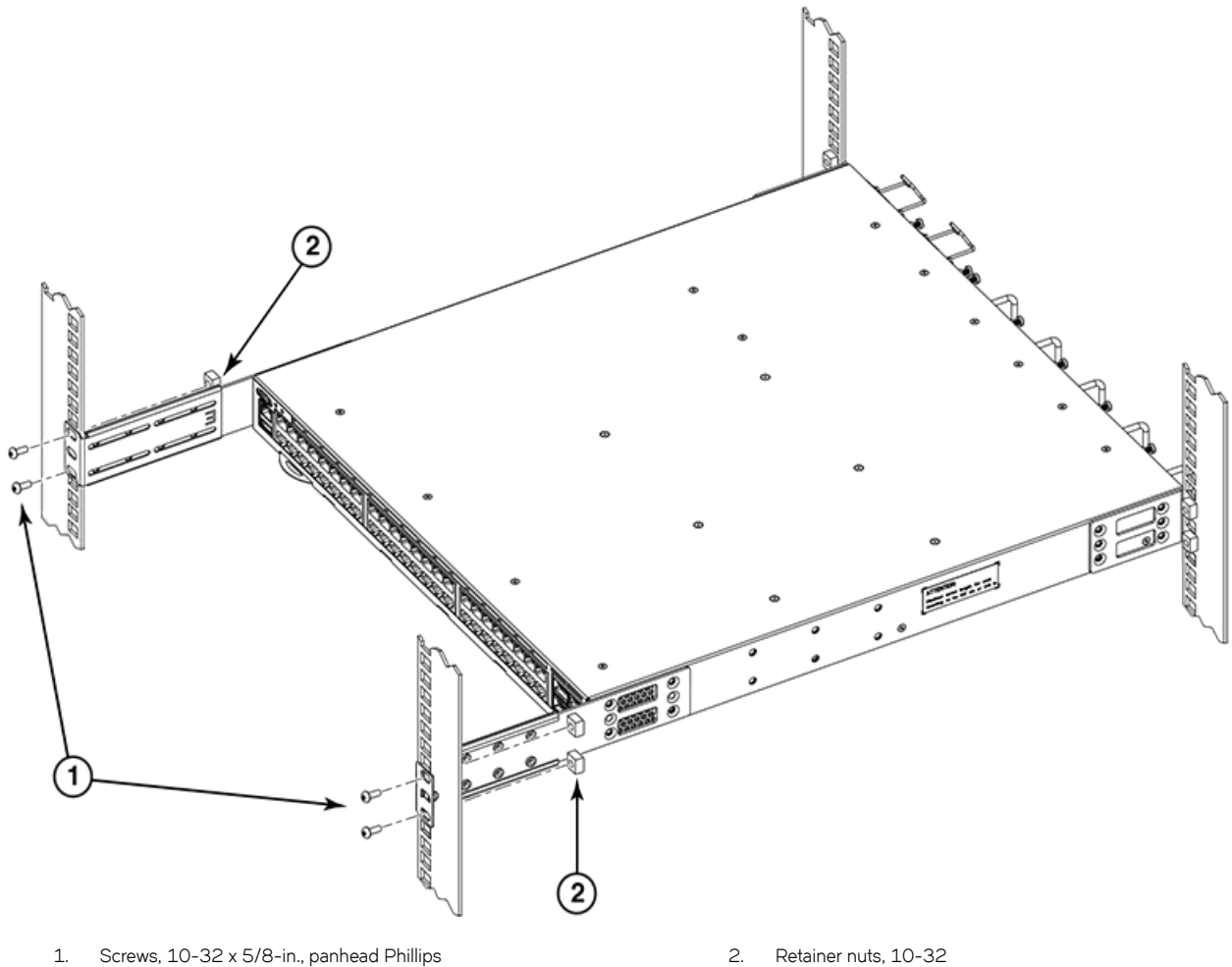

Installing the 1U, 1.5U, and 2U Mid-Mount Kit for Two-Post Racks (XBR-000165, XBR-000175, and XBR-R000292)

Use the following instructions to install a fixed-port device in a mid-mount configuration in a two-post rack using the 1U, 1.5U, and 2U Mid-Mount Kit for Two-Post Racks (XBR-000165, XBR-000175, and XBR-R000292).

Observe the following when mounting this device:

- Two people are required to install the device in a rack. One person holds the device, while the other secures the device to the rack.
- Before mounting your device, review any specific installation and facility requirements in this Hardware Installation Guide.

- Hardware devices illustrated in these procedures are only for reference and may not depict the device you are installing into the rack.

Time and items required

Allow 15 to 30 minutes to complete the installation procedure.

The following items are required to install a device using the 1U, 1.5U, or 2U Mid-Mount Kit for Two-Post Racks (XBR-000165, XBR-000175, and XBR-R000292).

- #2 Phillips torque screwdriver
- 1/4 inch slotted-blade torque screwdriver

NOTE

You may need two people to install the device, one to support the device, while the other secures it into the rack.



CAUTION

Use the screws specified in the procedure. Using longer screws can damage the device.

Parts list

The following parts are provided with the 1U, 1.5U, or 2U Mid-Mount Rack Kit for Two-Post Racks (XBR-000165, XBR-000175, and XBR-R000292).

NOTE

Depending on the device type, not all parts may be used in an installation.

FIGURE 31 Rack kit parts

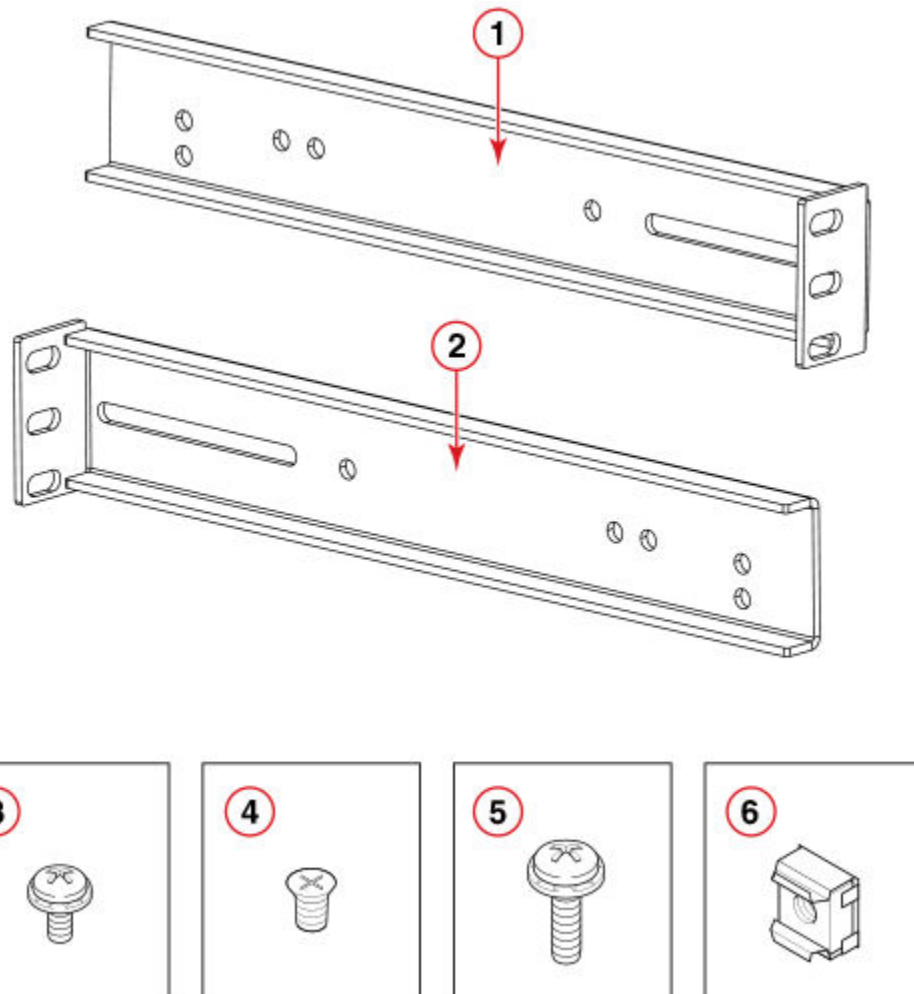

- | | |
|--|---|
| 1. Bracket, front right and back left | 4. Screw, 6-32 x 1/4-in., flathead Phillips (8) |
| 2. Bracket, front left and back right | 5. Screw, 10-32 x 5/8-in., panhead Phillips (8) |
| 3. Screw, 8-32 x 5/16-in., panhead Phillips (12) | 6. Retainer nut, 10-32 (8) |

Attaching the front brackets to the device



CAUTION

The device must be turned off and disconnected from the fabric during this procedure.

Complete the following steps to attach the front brackets to the device.

1. Position the right front bracket with the flat side against the right side of the device as shown in the following figure.
2. Insert two 8-32 x 5/16-in. screws into one of the pairs of vertically aligned holes in the bracket and then into the vertical pair of holes on the side of the device. To install the device in a recessed position in the rack, use the bracket holes that are set back from the end of the bracket.
3. Insert 8-32 x 5/16-in. screws through the rest of the holes in the bracket and into the corresponding holes in the device.

4. Repeat step 1 through step 3 to attach the left front bracket to the left side of the device.
5. Tighten all of the 8-32 x 5/16-in. screws to a torque of 15 in-lbs (17 cm-kgs).

FIGURE 32 Attaching the front brackets

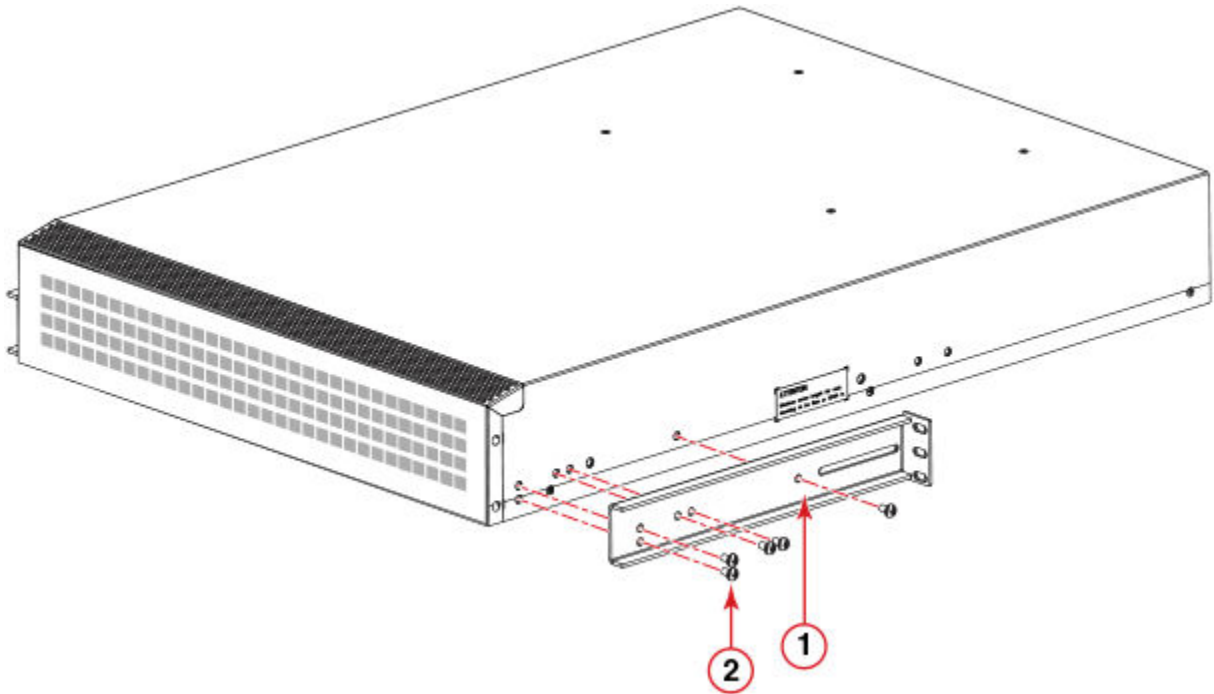

1. Bracket, front right

2. Screw, 8-32 x 5/16-in., panhead Phillips

NOTE

Install the device with the airflow aligned with any other devices in the rack. Some devices have airflow running from port side to fan side and others have the opposite arrangement. Make sure that the airflow for all devices moves in the same direction to maximize cooling. Refer to the Hardware Installation Guide for your product for specific requirements.

Attaching the device to a rack

Complete the following steps to install the device in the rack.

1. Position the device in the rack as shown in the following figure, providing temporary support under the device until the rail kit is secured to the rack.
2. Attach the right front bracket to the right rack rail using three 10-32 x 5/8-in. screws and three 10-32 retainer nuts.
3. Attach the left front bracket to the left rack rail using three 10-32 x 5/8-in. screws and three 10-32 retainer nuts.

4. Tighten all the 10-32 x 5/8-in. screws to a torque of 25 in-lbs (29 cm-kgs)

FIGURE 33 Attaching the device to a rack

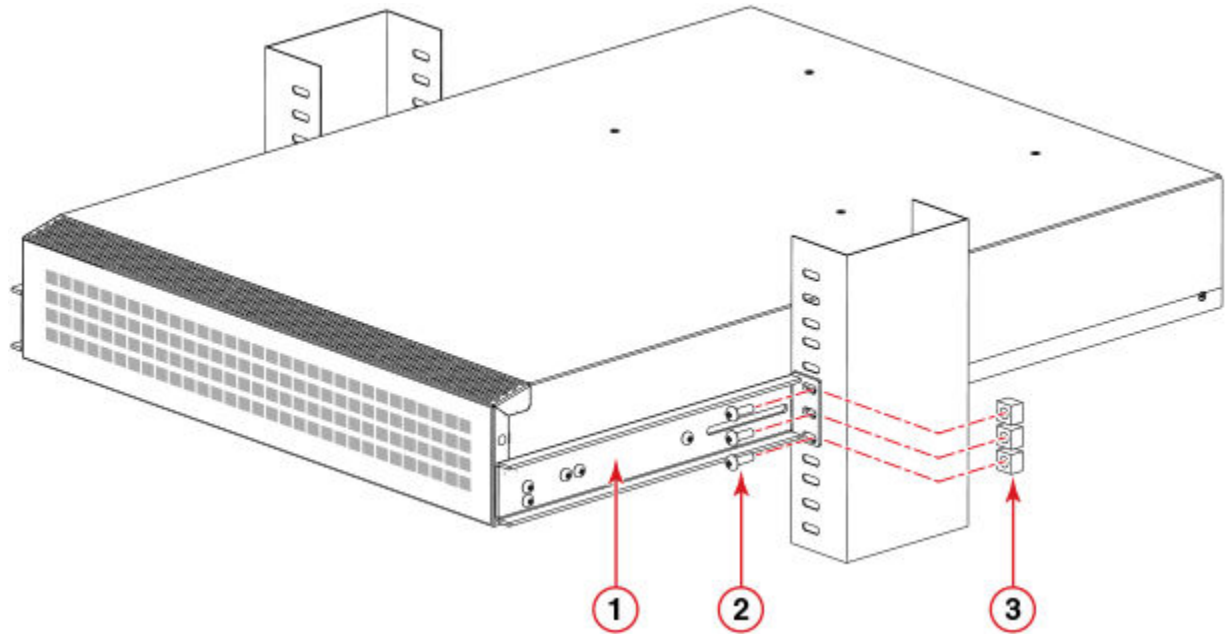

- | | |
|---|------------------------|
| 1. Bracket, front right | 3. Retainer nut, 10-32 |
| 2. Screw, 10-32 x 5/8-in., panhead Phillips | |

Attaching the rear brackets to the rack

NOTE

Do not use the rear brackets for the Extreme Networks 6505, 6510, or 6520 switches.

Complete the following steps to attach the rear brackets to the rack.

1. Position the right rear bracket in the right rear of the device as shown in the following figure.
2. Attach the brackets using three 10-32 x 5/8-in. screws and 10-32 retainer nuts.
3. Repeat step 1 and step 2 to attach the left rear bracket.

4. Adjust the brackets to the rack depth and tighten the screws to a torque of 25 in-lbs (29 cm-kgs).

FIGURE 34 Attaching the rear brackets to a rack

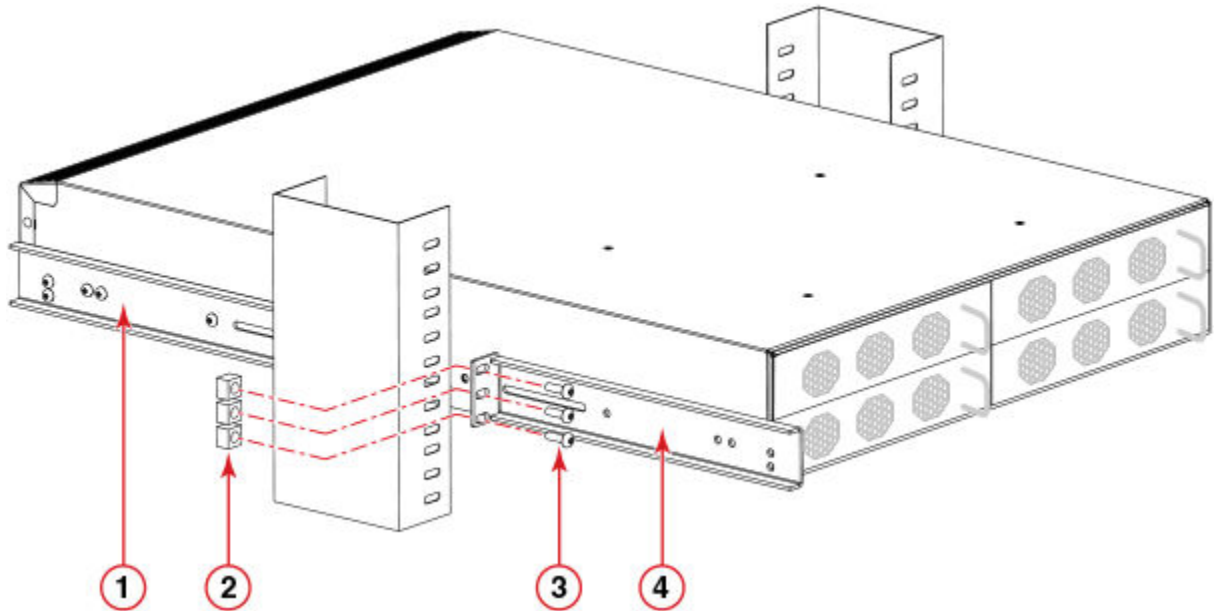

1. Bracket, front right
2. Retainer nut, 10-32

3. Screw, 10-32 x 5/8-in., flathead Phillips
4. Bracket, rear right

Attaching the rear brackets to the device

Complete the following steps to attach the rear brackets to the device.

1. Align the right rear bracket to the right rear of the device and use two 8-32 x 5/16-in. screws to attach the bracket to the device as shown in the following figure.
2. Align the left rear bracket to the left rear of the device and use two 8-32 x 5/16-in. screws to attach the bracket to the device as shown in the following figure.

3. Tighten all the screws to a torque of 9 in-lbs (10 cm-kgs).

FIGURE 35 Attaching the rear brackets to the device

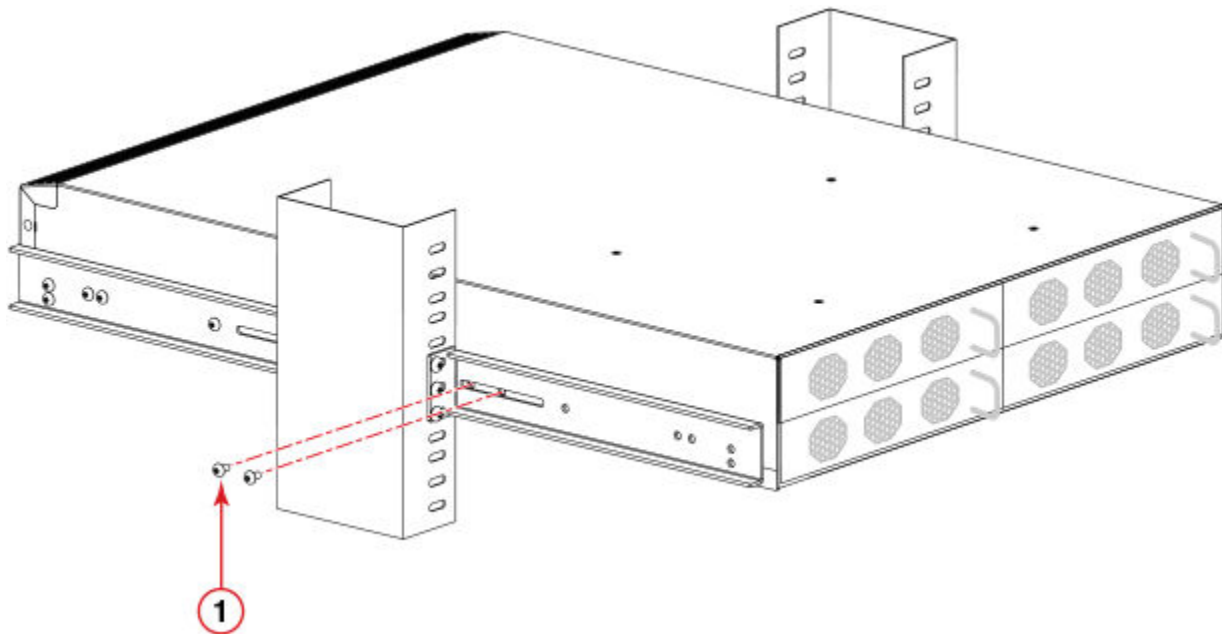

1. Screw, 8-32 x 5/16-in., panhead Phillips

Installing the 1U and 2U Flush-Mount Rack Kit for Two-Post Racks (XBR-000307 and XBR-R000293)

Use the following instructions to install a fixed-port device in a flush-mount configuration using the 1U and 2U Flush-Mount Rack Kit for Two-Post Racks (XBR-000307 and XBR-R000293).

Observe the following when mounting this device:

- Two people are required to install the device in a rack. One person holds the device, while the other secures the device in the rack.
- Before mounting your device, review any specific installation and facility requirements in this Hardware Installation Guide.
- Hardware devices illustrated in these procedures are only for reference and may not depict the device you are installing into the rack.

Time and items required

Allow 15 to 30 minutes to complete this procedure.

The following items are required to install a device using the 1U and 2U Flush-Mount Rack Kit for Two-Post Racks (XBR-000307 and XBR-R000293).

- Phillips #2 torque screwdriver
- 1/4-inch slotted blade torque screwdriver

NOTE

You may need two people to install the device, one to support the device, while the other secures it into the rack.



CAUTION

Use the screws specified in the procedure. Using longer screws can damage the device.

Parts list

The following parts are provided with the 1U and 2U Flush-Mount Rack Kit for Two-Post Racks (XBR-000307 and XBR-R000293):

FIGURE 36 Rack kit parts

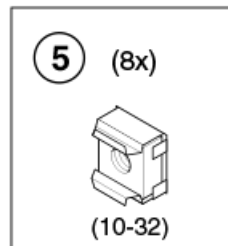
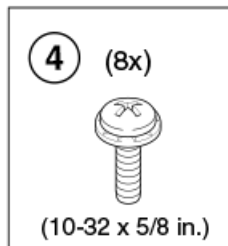
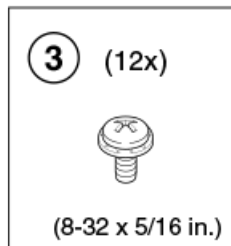
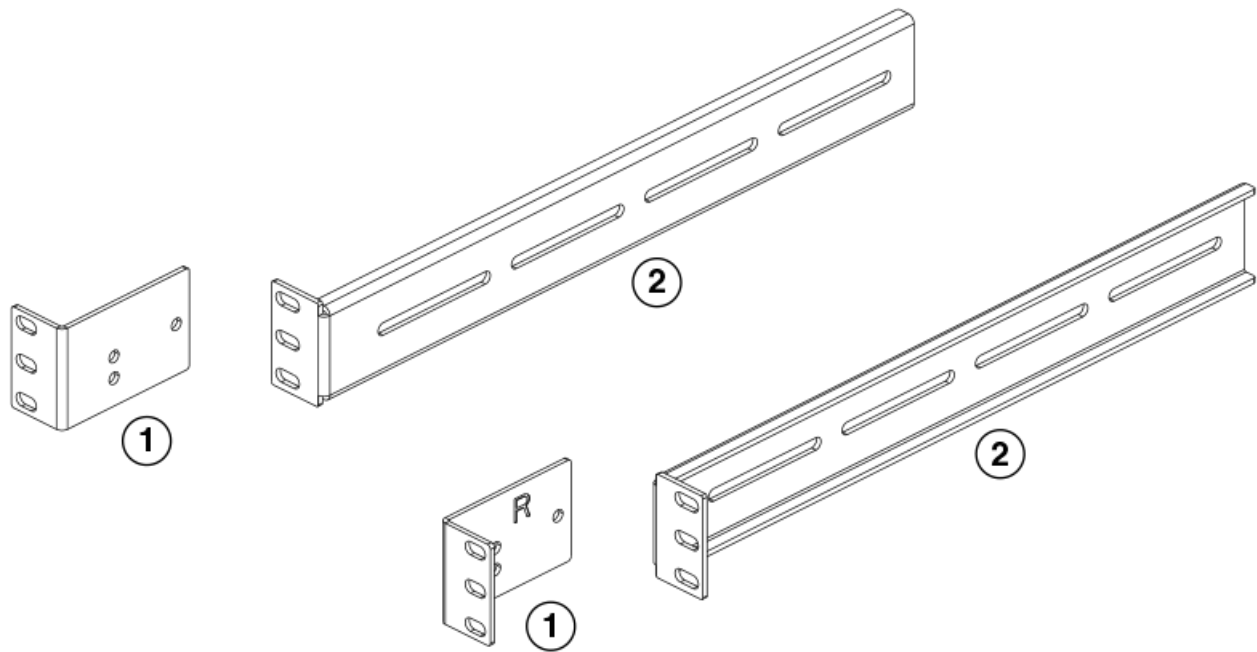

- | | |
|---|---|
| <ul style="list-style-type: none"> 1. Front brackets, right and left (2) 2. Rear brackets, right and left (2) 3. Screw, 8-32 x 5/16-in., panhead Phillips (12) | <ul style="list-style-type: none"> 4. Screw, 10-32 x 5/8-in., panhead Phillips (8) 5. Retainer nut, 10-32 (8) |
|---|---|

NOTE

Not all parts may be used with certain installations depending on the device type.

NOTE

Although this document describes how to install both single height (1U) and double height (2U) devices, the illustrations show a 2U device as a typical installation.

Attaching the front brackets to the device



CAUTION

The device must be turned off and disconnected from the fabric during this procedure.

Complete the following steps to attach the front brackets to the device.

1. Position the right front bracket with the flat side against the right side of the device as shown in the following figure.
2. Insert two 8-32 x 5/16-in. screws through the pair of vertically aligned holes in the bracket and then into the pair of holes on the side of the device.
3. Insert another 8-32 x 5/16-in. screw through the third hole in the bracket and into the corresponding hole in the device.
4. Repeat step 1 through step 3 to attach the left front bracket to the left side of the device. Tighten all 8-32 x 5/16-in. screws to a torque of 15 in-lbs. (17 cm-kgs).

FIGURE 37 Attaching the front brackets

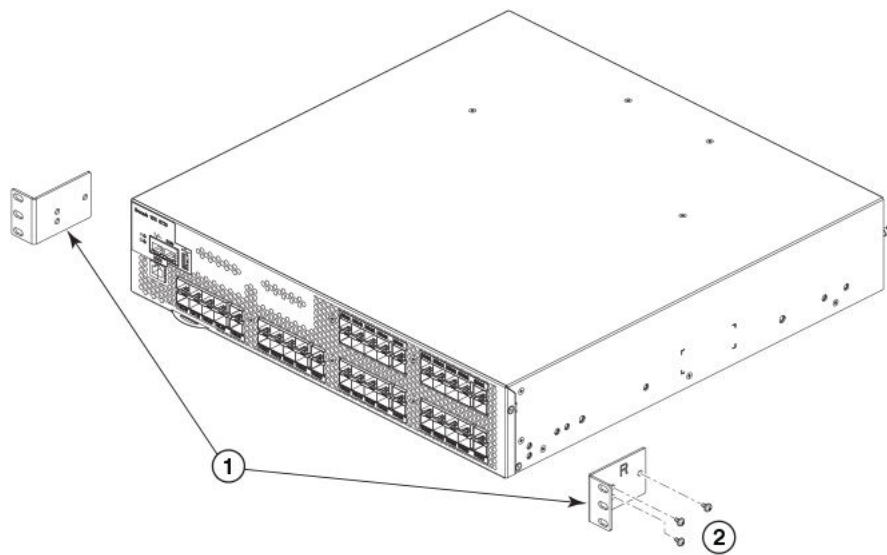

1. Front brackets, right and left

2. Screw, 8-32 x 5/16-in., panhead Phillips

Attaching the front brackets to the rack

NOTE

Install the device with the airflow aligned with any other devices in the rack. Some devices have airflow running from port side to fan side and others have the opposite arrangement. Make sure that the airflow for all devices moves in the same direction to maximize cooling. Refer to the Hardware Installation Guide for your product for specific requirements.

Complete the following steps to install the device in the rack.

1. Position the device in the rack as shown in the following figure, providing temporary support under the device until the rail kit is fully secured to the rack.
2. Attach the right front bracket to the right rack upright using three 10-32 x 5/8-in. screws and three retainer nuts as shown in the following figure.
3. Attach the left front bracket to the left rack upright using three 10-32 x 5/8-in. screws and three retainer nuts.
4. Tighten all the 10-32 x 5/8-in. screws to a torque of 25 in-lbs. (29 cm-kgs).

FIGURE 38 Attaching front brackets to a rack

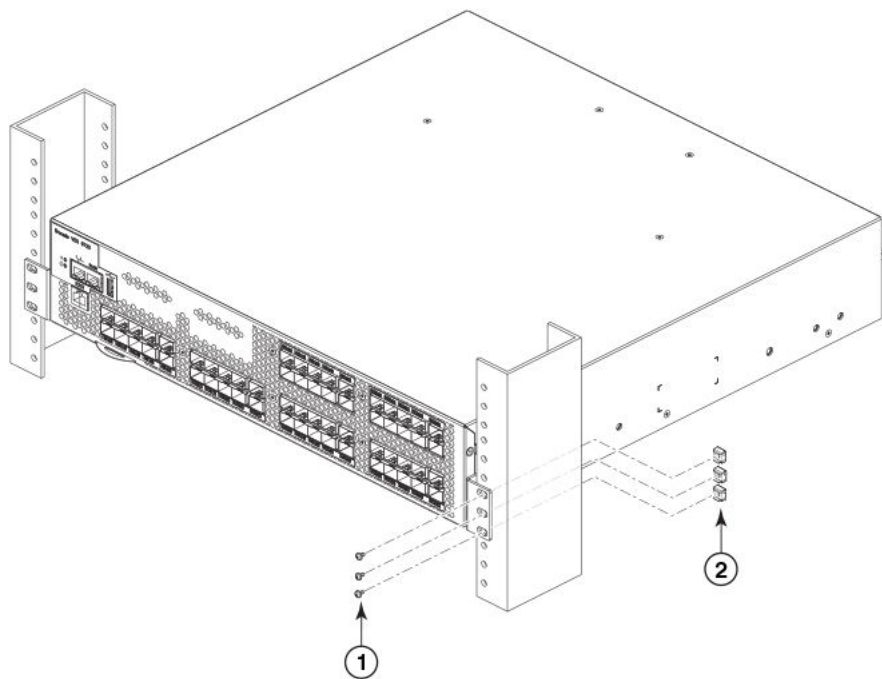

1. Screw, 10-32 x 5/8-in., panhead Phillips

2. Retainer nut, 10-32

Attaching the rear brackets to the rack

Complete the following steps to attach the rear brackets to the rack.

1. Position the right rear bracket in the right rear of the device as shown in the following figure.
2. Attach the brackets to the right rack upright using three 10-32 x 5/8-in. screws and retainer nuts.
3. Repeat step 1 and step 2 to attach the left rear bracket to the left rack upright.

4. Tighten all the 10-32 x 5/8-in. screws to a torque of 25 in-lbs. (29 cm-kgs).

FIGURE 39 Attaching the rear brackets to a rack

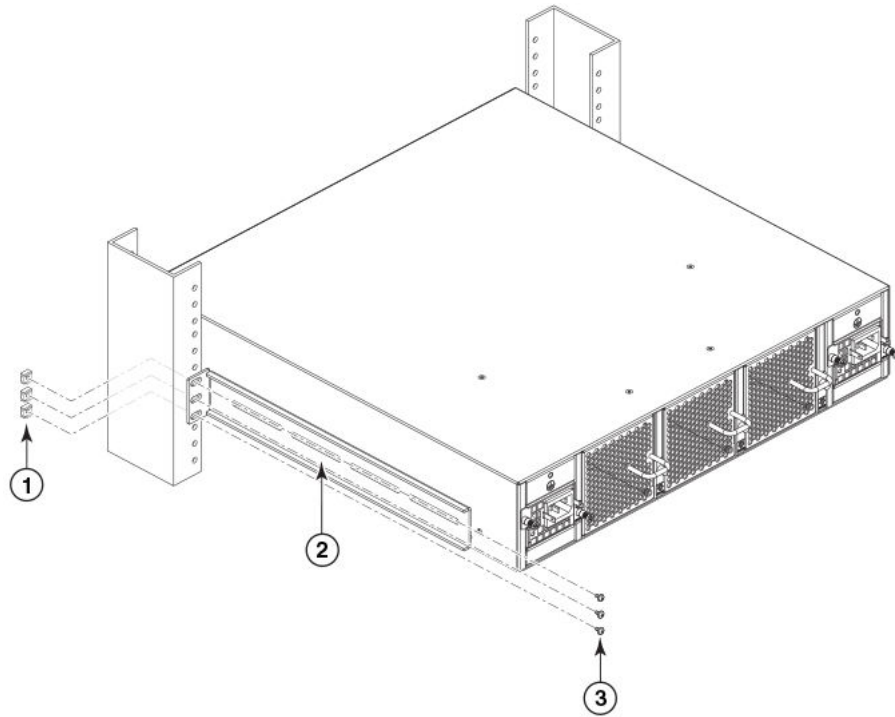

1. Retainer nut, 10-32
2. Rear brackets, right (left side similar)

3. Screw, 10-32 x 5/8-in., panhead Phillips

Attaching the rear brackets to the device

Complete the following steps to attach the rear brackets to the device.

1. Align the right rear bracket to the right rear of the device and using two 8-32 x 5/16-in. screws, attach the bracket to the device as shown in the following figure.
2. Align the left rear bracket to the left rear of the device and using two 8-32 x 5/16-in. screws, attach the bracket to the device.

- Tighten all the 8-32 x 5/16-in. screws to a torque of 15 in-lbs. (17 cm-kgs).

FIGURE 40 Attaching the rear bracket to the device

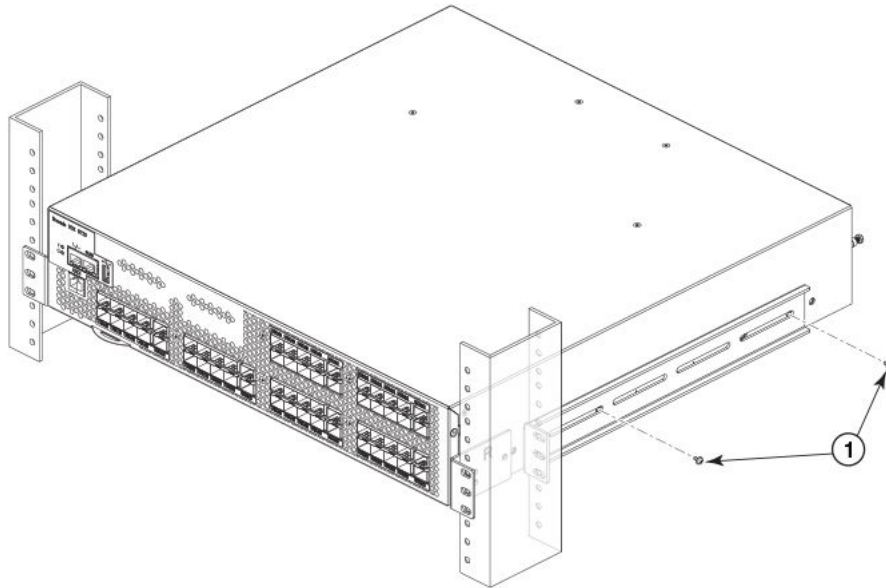

- Screws, 8-32 x 5/16-in., panhead Phillips

Installing the Universal Four-Post Rack Kit (XBR-R000296)

Use the following instructions to install 1U and 2U devices in EIA racks that are between L-12.7 to 81.28 cm deep (L-5.0 to 32.0 in.), where L is the chassis depth, using the Universal Four-Post Rack Kit (XBR-R000296).

There are two ways you can mount the device in a four-post rack:

- With the port side flush with the front posts.
- With the nonport side flush with the rear posts in a recessed position. A recessed position allows a more gradual bend in the fiber-optic cables connected to the switch and less interference in the aisle at the front of the rack.

TABLE 1 Space requirements

Chassis with port-side side vents	Notes	Chassis depth	Minimum rack depth	Maximum rack depth
No	Applicable to port-side and nonport-side flush mounts.	L	L-12.7 cm (L-5 in.)	81.28 cm (32 in.)
Yes	Applicable to port-side flush mounts.	L	L-12.7 cm (L-5 in.)	81.28 cm (32 in.)
Yes	Applicable to nonport-side flush mounts.	L	L	81.28 cm (32 in.)

Note that if chassis depth (L) is less than 40.64 cm (16 in.), the chassis will not fit into a rack with a maximum depth of 81.28 cm (32 in.) using the universal four-post rack kit. The maximum rack depth for a chassis less than 40.64 cm (16 in.) is 81.28 cm (32 in.) minus the difference between the chassis depth and 40.64 cm (16 in.). For example, a chassis with a depth (L) of 35.56 cm (14 in.) is 5.08 cm (2

in.) smaller than 40.64 cm (1.6 in.), so it will install into a rack with a maximum depth of 81.28 cm (32 in.) - 5.08 cm (2 in.) = 76.2 cm (30 in.).

Observe the following when mounting this device:

- Two people are required to install the device in a rack. One person holds the device, while the other screws in the front and rear brackets.
- Before mounting your device, review any specific installation and facility requirements in this Hardware Installation Guide.
- Hardware devices illustrated in these procedures are only for reference and may not depict the device you are installing into the rack.

Time and items required

Allow 15 to 30 minutes to complete the installation.

The following items are required to install the device using the Universal Four-Post Rack Kit:

- #2 Phillips torque screwdriver
- 1/4-inch slotted-blade torque screwdriver

Parts list

The following parts are provided with the 1U, 1.5U, and 2U Universal Kit for Four Post Racks Installation (XBR-R000296).

FIGURE 41 Rack kit parts

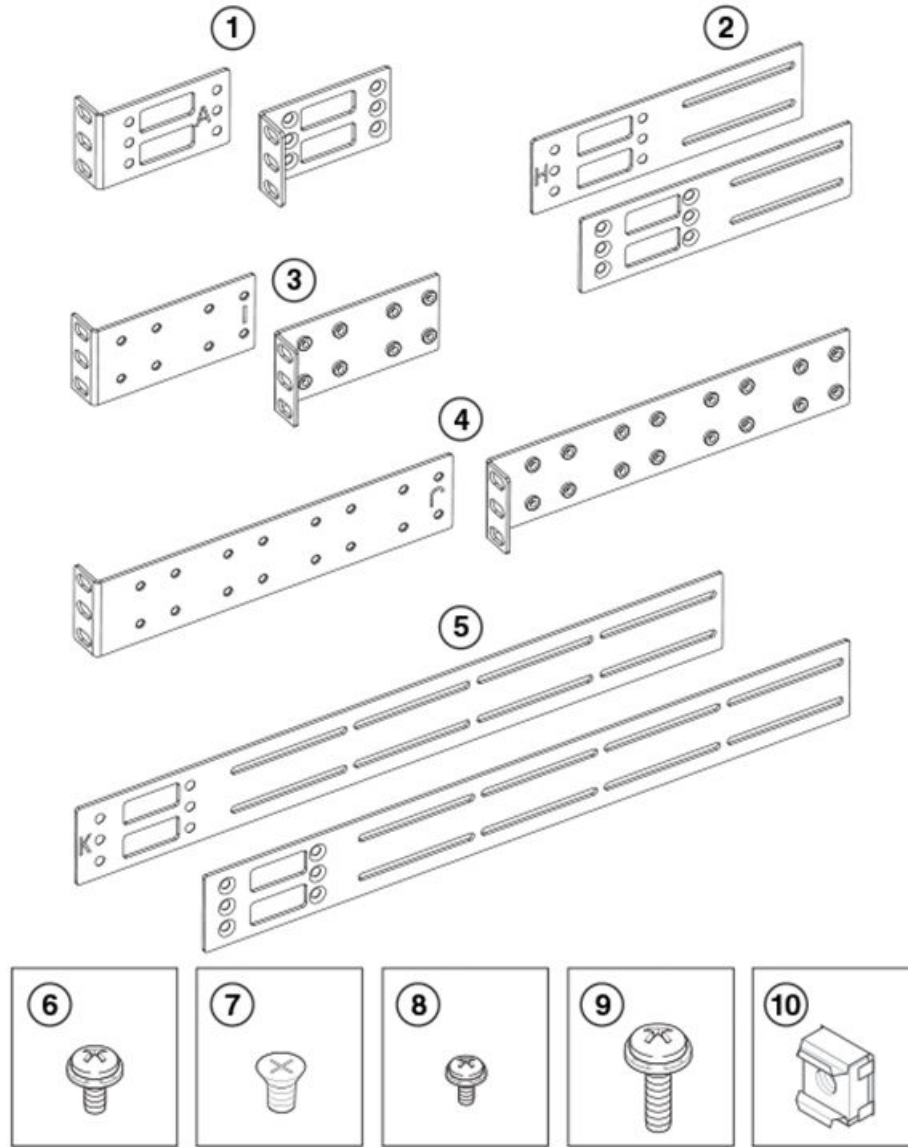

- | | |
|-----------------------------------|---|
| 1. Front brackets (2) | 6. Screw, 8-32 x 5/16-in., panhead Phillips (8) |
| 2. Extension brackets, medium (2) | 7. Screw, 8-32 x 5/16-in., flathead Phillips (16) |
| 3. Rear brackets, short (2) | 8. Screw, 6-32 x 1/4-in., panhead Phillips (8) |
| 4. Rear brackets, long (2) | 9. Screw, 10-32 x 5/8-in., panhead Phillips (8) |
| 5. Extension brackets, long (2) | 10. Retainer nut, 10-32 (8) |

Ensure that the items listed and illustrated are included in the kit. Note that not all parts may be used with certain installations depending on the device type.



CAUTION

Use the screws specified in the procedure. Using longer screws can damage the device.

Flush-front mounting



CAUTION

The device must be turned off and disconnected from the fabric during this procedure.

NOTE

The illustrations in the rack installation procedures are for reference only and may not show the device that you are installing.

Complete the following tasks to install the device in a four-post rack.

1. [Attaching the front brackets](#) on page 64
2. [Attaching the bracket extensions to the device](#) on page 65
3. [Installing the device in the rack](#) on page 66
4. [Attaching the rear brackets to the extensions](#) on page 67
5. [Attaching the rear brackets to the rack posts](#) on page 68

Attaching the front brackets

Complete the following steps to attach the front brackets to the device.

1. Position the right front bracket with the flat side against the right side of the device at the front of the device, as shown in [Figure 42](#).
2. Insert four 8-32 x 5/16-in. flathead screws through the vertically aligned holes in the bracket and then into the holes on the side of the device. Use the upper and lower screw holes, leaving the center holes empty.
3. Repeat step 1 and step 2 to attach the left front bracket to the left side of the device.

4. Tighten all the 8-32 x 5/16-in. screws to a torque of 15 in-lb (17 cm-kg).

FIGURE 42 Attaching the front brackets

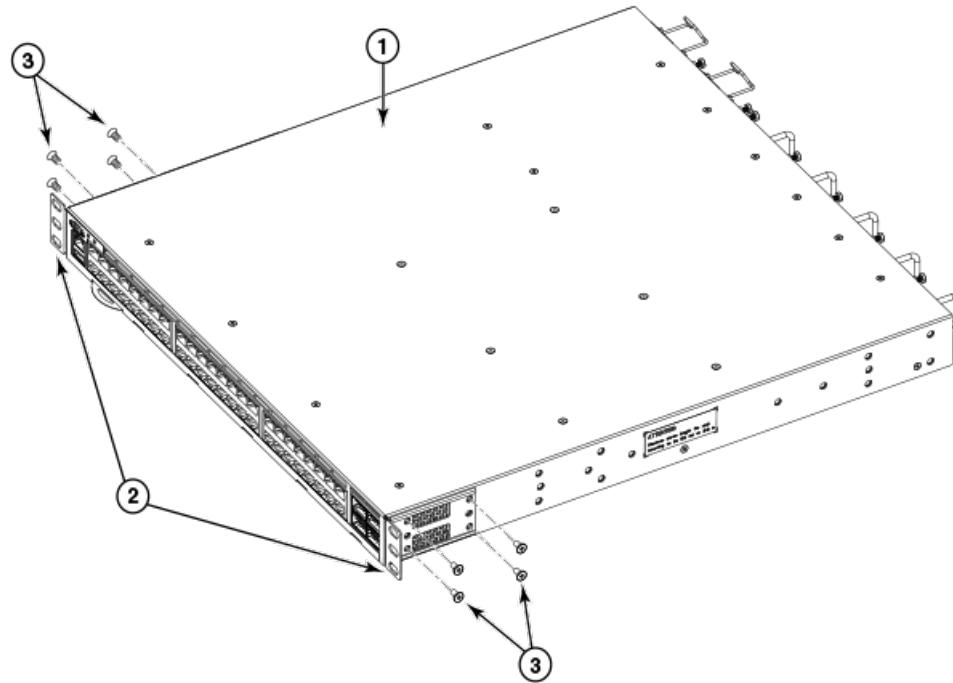

1. The device
2. Front brackets

3. Screws, 8-32 x 5/16-in., flathead Phillips

Attaching the bracket extensions to the device

Complete the following steps to attach the extension brackets to the device. There are medium and long extension brackets that you can use for this step.

1. Select the proper length bracket extension for your rack depth.
2. Position the right bracket extension along the side of the device as shown in [Figure 43](#).
3. Insert four 8-32 x 5/16-in. flathead screws through the vertically aligned holes in the bracket extension and then into the holes on the side of the device. Use the upper and lower screw holes, leaving the center holes empty.
4. Repeat step 2 and step 3 to attach the left bracket extension to the left side of the device.

5. Tighten all the 8-32 x 5/16-in. screws to a torque of 15 in-lb (17 cm-kg).

FIGURE 43 Attaching the bracket extensions to the device

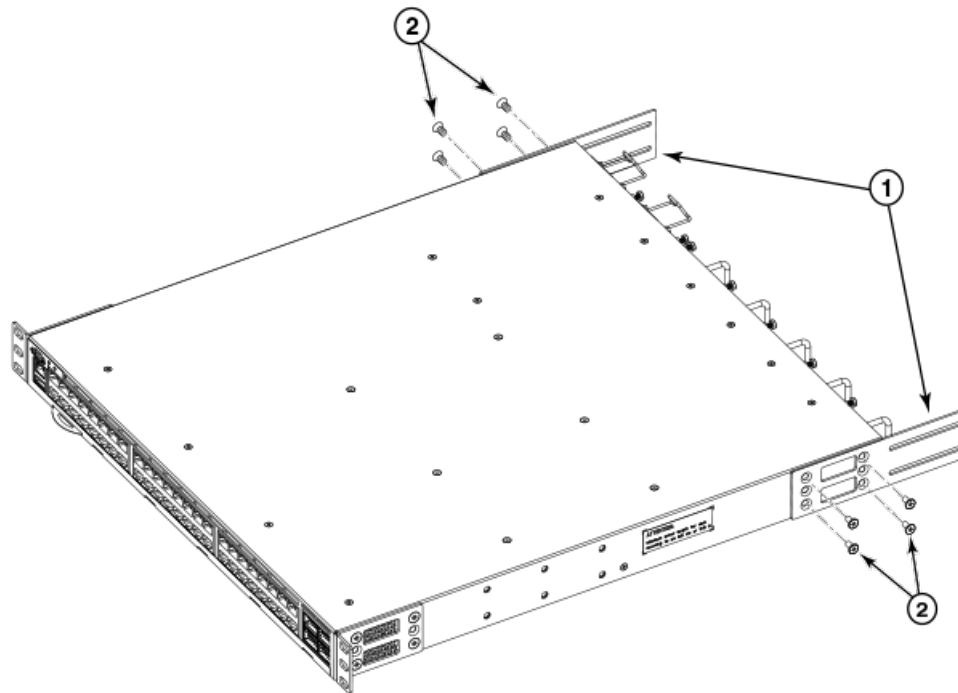

1. Bracket extension

2. Screws, 8-32 x 5/16-in., flathead Phillips

Installing the device in the rack

Complete the following steps to install the device in the rack.

1. Position the device in the rack, as shown in [Figure 44](#), providing temporary support under the device until the rail kit is secured to the rack.
2. Attach the right front bracket to the right front rack post using two 10-32 x 5/8-in. panhead screws and two retainer nuts. Use the upper and lower holes in the bracket.
3. Attach the left front bracket to the left front rack post using two 10-32 x 5/8-in. panhead screws and two retainer nuts. Use the upper and lower holes in the bracket.

4. Tighten all the 10-32 x 5/8-in. screws to a torque of 25 in-lb (29 cm-kg).

FIGURE 44 Positioning the device in the rack

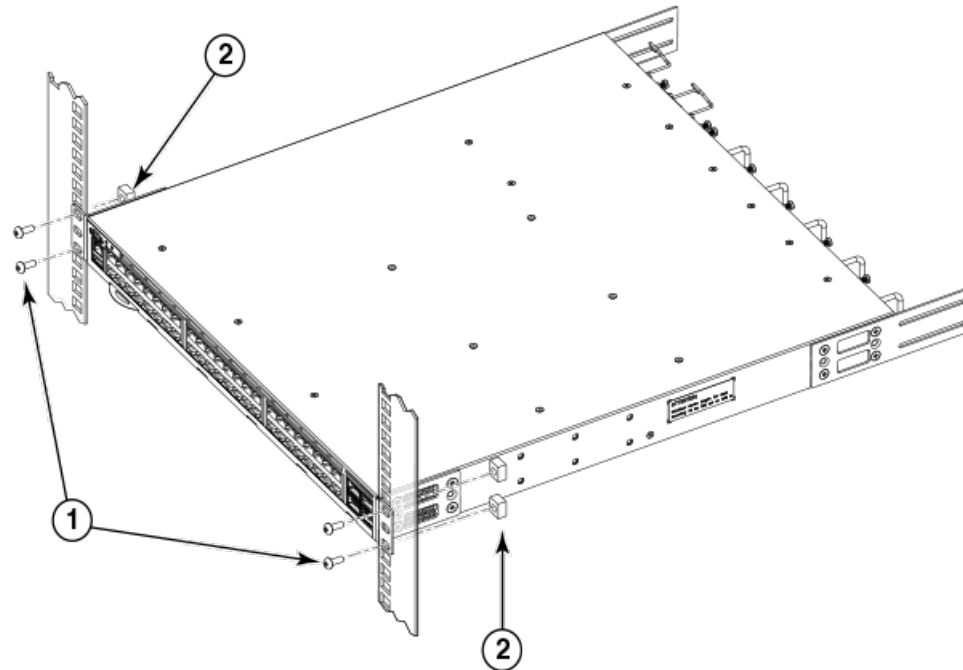

1. Screws, 10-32 x 5/8-in., panhead Phillips

2. Retainer nuts, 10-32

Attaching the rear brackets to the extensions

Complete the following steps to attach the rear brackets to the extensions. There are short and long rear brackets that you can use for this step. Choose the correct bracket for the depth of your rack.

1. Select the proper length rear bracket for your rack depth.
2. Slide the right rear bracket onto the right bracket extension, as shown in the following figure.
3. Attach the brackets using four 6-32 x 1/4-in. panhead screws.
If possible, leave at least one empty vertical pair of holes between the screws for better support.
4. Repeat step 2 and 3 to attach the left rear bracket to the left bracket extension.

- Adjust the brackets to the rack depth and tighten all the 6-32 x 1/4-in. screws to a torque of 9 in-lb (10 cm-kg).

FIGURE 45 Attaching the rear brackets to the extensions

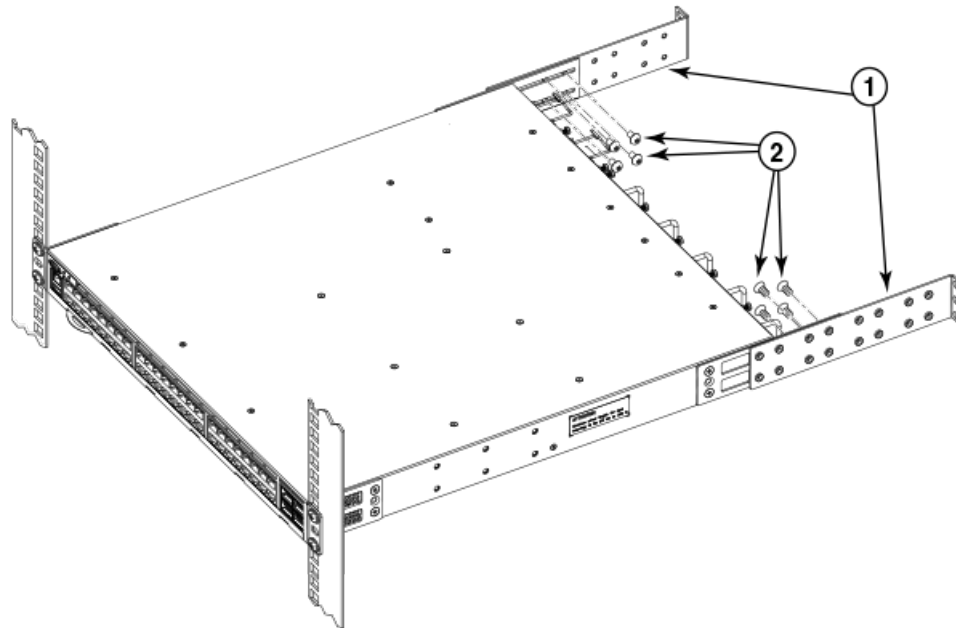

1. Rear brackets

2. Screws, 6-32 x 1/4-in., panhead Phillips

Attaching the rear brackets to the rack posts

Complete the following steps to attach the rear brackets to the rack posts.

- Attach the right rear bracket to the right rear rack post using two 10-32 x 5/8-in. panhead screws and two retainer nuts, as shown in [Figure 46](#). Use the upper and lower holes in the bracket.
- Attach the left rear bracket to the left rear rack post using two 10-32 x 5/8-in. panhead screws and two retainer nuts. Use the upper and lower holes in the bracket.

3. Tighten all the 10-32 x 5/8-in. screws to a torque of 25 in-lb (29 cm-kg).

FIGURE 46 Attaching the rear brackets to the rack posts

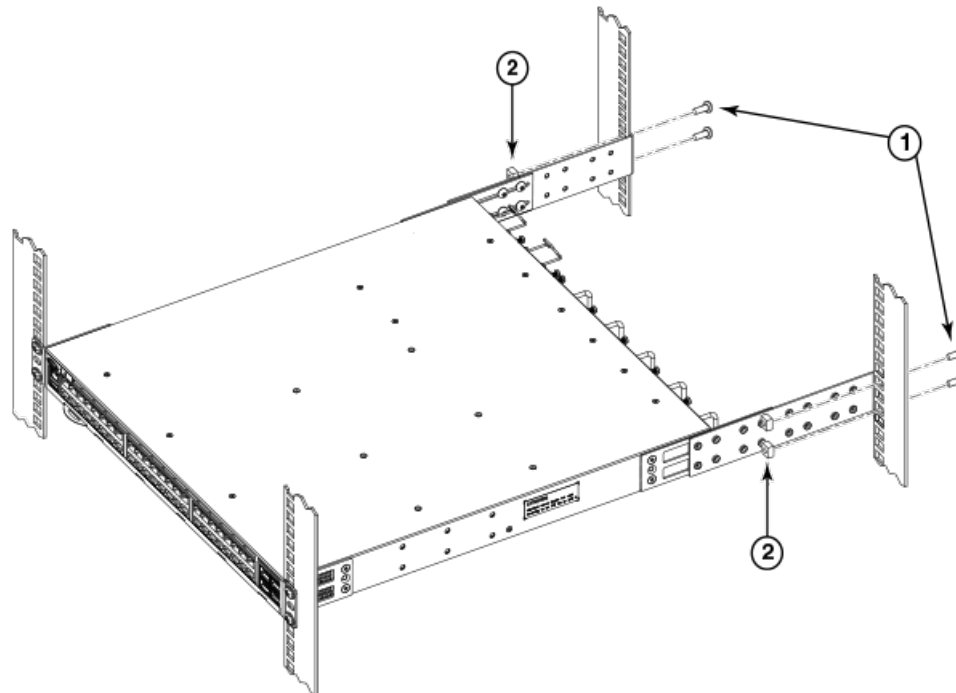

1. Screws, 10-32 x 5/8-in., panhead Phillips

2. Retainer nuts, 10-32

Flush-rear (recessed) mounting

The flush-rear (recessed) mounting is similar to the flush-front mounting except that the brackets are reversed on the device.



CAUTION

The device must be turned off and disconnected from the fabric during this procedure.

NOTE

The illustrations in the rack installation procedures show a 1U device, but the instructions are the same for a 2U device. The illustrations in the rack installation procedures are for reference only and may not show the actual device.

Complete the following tasks to install the device in a four-post rack:

1. [Attaching the front brackets to the rear of the device](#) on page 70
2. [Attaching the extensions to the front of the device](#) on page 70
3. [Installing the device in the rack](#) on page 71
4. [Attaching the rear brackets to the extensions at the front of the device](#) on page 72
5. [Attaching the rear brackets to the front rack posts](#) on page 74

Attaching the front brackets to the rear of the device

NOTE

In this installation, the brackets are named as listed in the parts list even though the installation of the brackets is reversed from the flush-front installation.

Complete the following steps to attach the front brackets to the rear of the device.

1. Position the right front bracket with the flat side against the right rear side of the device, as shown in [Figure 47](#).
2. Insert four 8-32 x 5/16-in. flathead screws through the vertically aligned holes in the bracket and then into the holes on the side of the device. Use the upper and lower screw holes, leaving the center holes empty.
3. Repeat step 1 and step 2 to attach the left front bracket to the left side of the device.
4. Tighten all the 8-32 x 5/16-in. screws to a torque of 15 in-lb (17 cm-kg).

FIGURE 47 Attaching the front brackets to the rear of the device

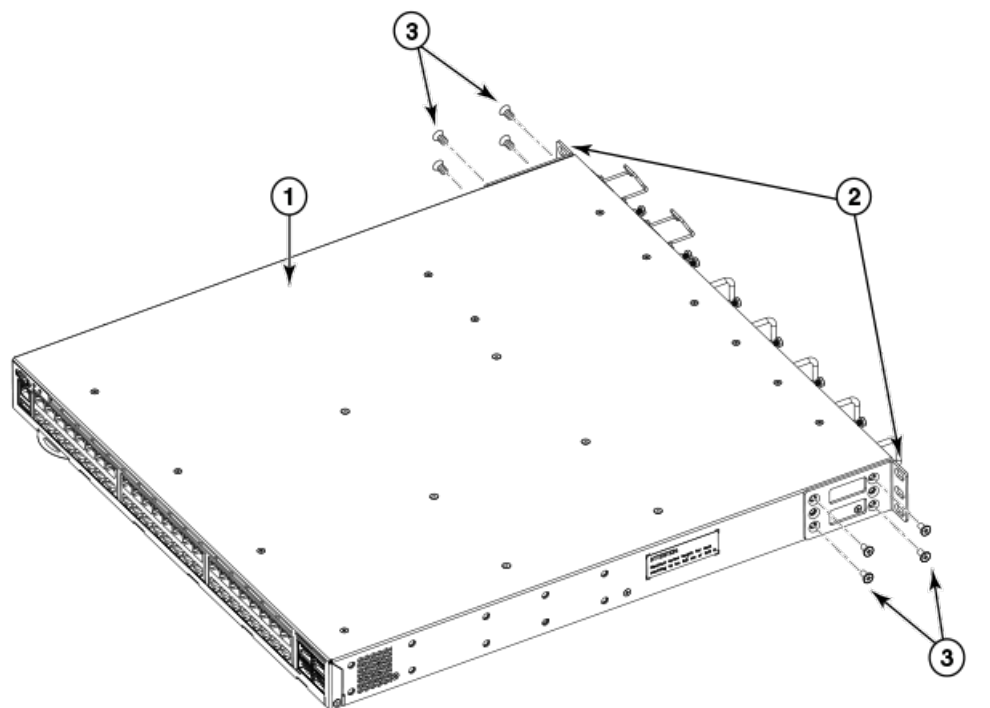

1. The device
2. Front brackets

3. Screws, 8-32 x 5/16-in., flathead Phillips

Attaching the bracket extensions to the front of the device

Complete the following steps to attach the bracket extensions to the front of the device. There are medium and long extension brackets that you can use for this step.

1. Select the proper length extension bracket for your rack depth.
2. Position the right bracket extension along the side of the device as shown in [Figure 48](#).
3. Insert four 8-32 x 5/16-in. flathead screws through the vertically aligned holes in the bracket extension and then into the holes on the side of the device. Use the upper and lower screw holes, leaving the center holes empty.

4. Repeat step 2 and step 3 to attach the left front bracket extension to the left side of the device.
5. Tighten all the 8-32 x 5/16-in. screws to a torque of 15 in-lb (17 cm-kg).

FIGURE 48 Attaching the bracket extensions to the device

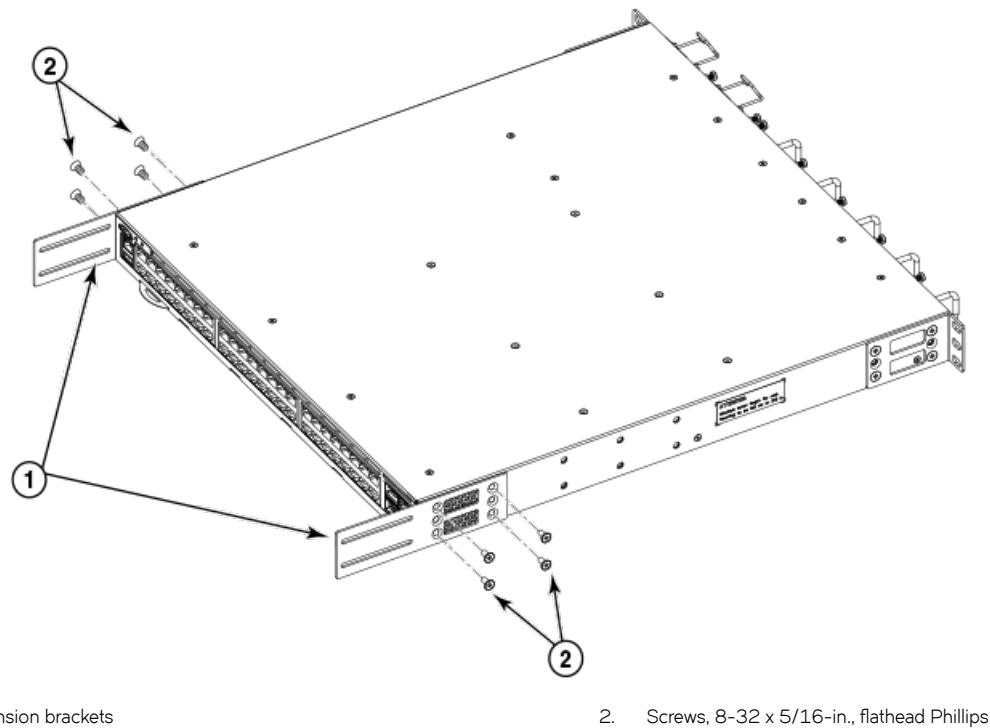

Installing the device in the rack

Complete the following steps to install the device in the rack.

1. Position the device in the rack, as shown in [Figure 49](#), providing temporary support under the device until the rail kit is secured to the rack.
2. Attach the right front bracket to the right rear rack post using two 10-32 x 5/8-in. panhead screws and two retainer nuts. Use the upper and lower holes in the bracket.
3. Attach the left front bracket to the left rear rack post using two 10-32 x 5/8-in. panhead screws and two retainer nuts. Use the upper and lower holes in the bracket.

4. Tighten all the 10-32 x 5/8-in. screws to a torque of 25 in-lb (29 cm-kg).

FIGURE 49 Positioning the device in the rack

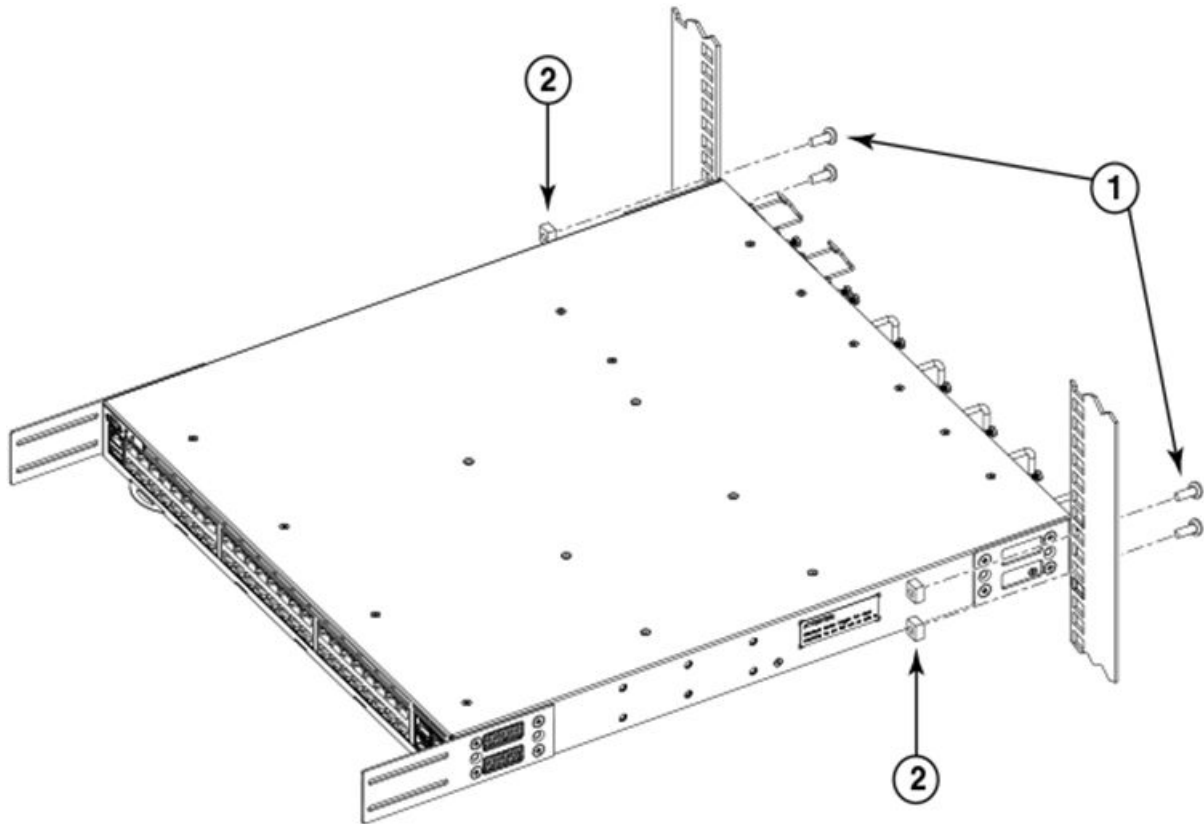

1. Screws, 10-32 x 5/8-in., panhead Phillips

2. Retainer nuts, 10-32

Attaching the rear brackets to the extensions at the front of the device

Complete the following steps to attach the rear brackets to the extensions. There are short and long front brackets that you can use for this step.

1. Select the proper length rear bracket for your rack depth.
2. Slide the right rear bracket onto the right extension.

The short rear brackets are shown in [Figure 50](#). Use the first and third vertical pairs of holes for the screws.

Refer to [Figure 51](#) for the positioning of the short or long brackets and screws.

3. Attach the brackets using four 6-32 x 1/4-in. panhead screws.
4. Repeat step 2 and step 3 to attach the left rear bracket to the left extension.

- Adjust the brackets to the rack depth and tighten all the 6-32 x 1/4-in. screws to a torque of 9 in-lb (10 cm-kg).

FIGURE 50 Attaching the rear brackets to the extensions at the front of the device

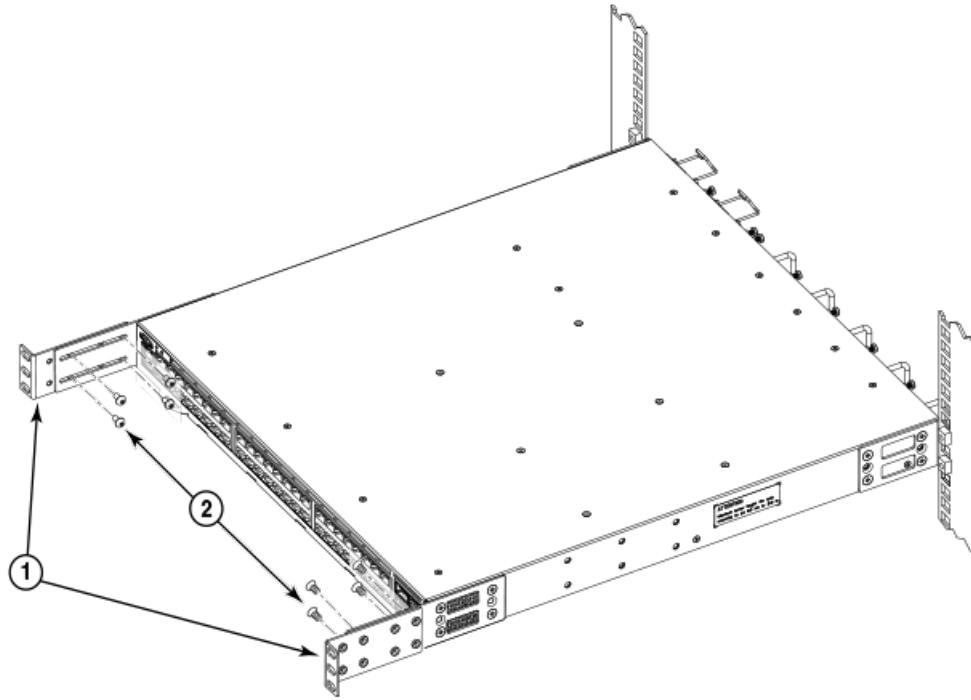

1. Rear brackets, short

2. Screws, 6-32 x 1/4-in., panhead Phillips

FIGURE 51 Attaching the short or long rear brackets to the extensions

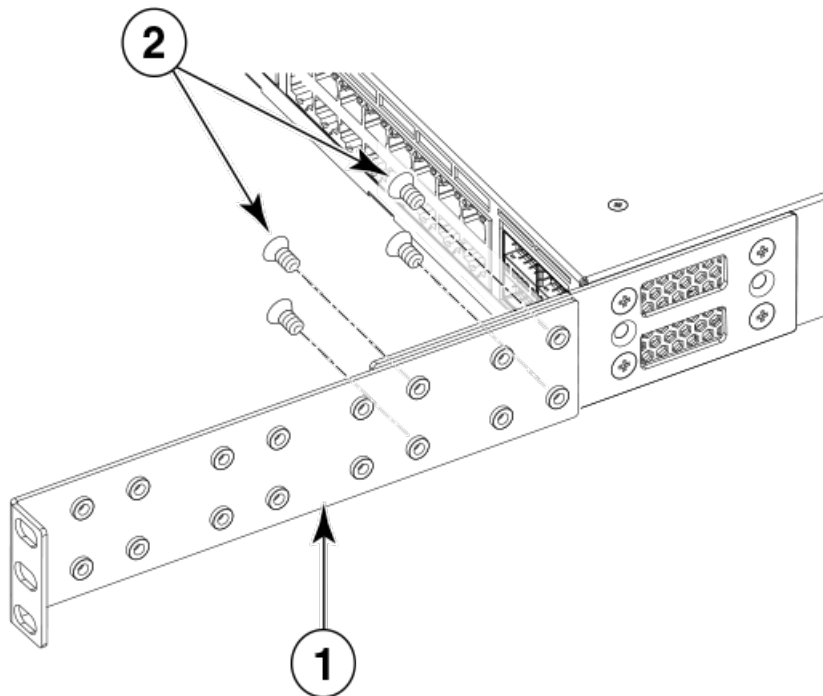

1. Rear bracket, short or long

2. Screws, 6-32 x 1/4-in., panhead Phillips

Attaching the rear brackets to the front rack posts

Complete the following steps to attach the rear brackets to the front rack posts.

1. Attach the right rear bracket to the right front rack post using two 10-32 x 5/8-in. screws and two retainer nuts, as shown in [Figure 52](#). Use the upper and lower holes in the bracket.
2. Attach the left rear bracket to the left front rack post using two 10-32 x 5/8-in. screws and two retainer nuts. Use the upper and lower holes in the bracket.
3. Tighten all the 10-32 x 5/8-in. screws to a torque of 25 in-lb (29 cm-kg).

FIGURE 52 Attaching the rear brackets to the front rack posts

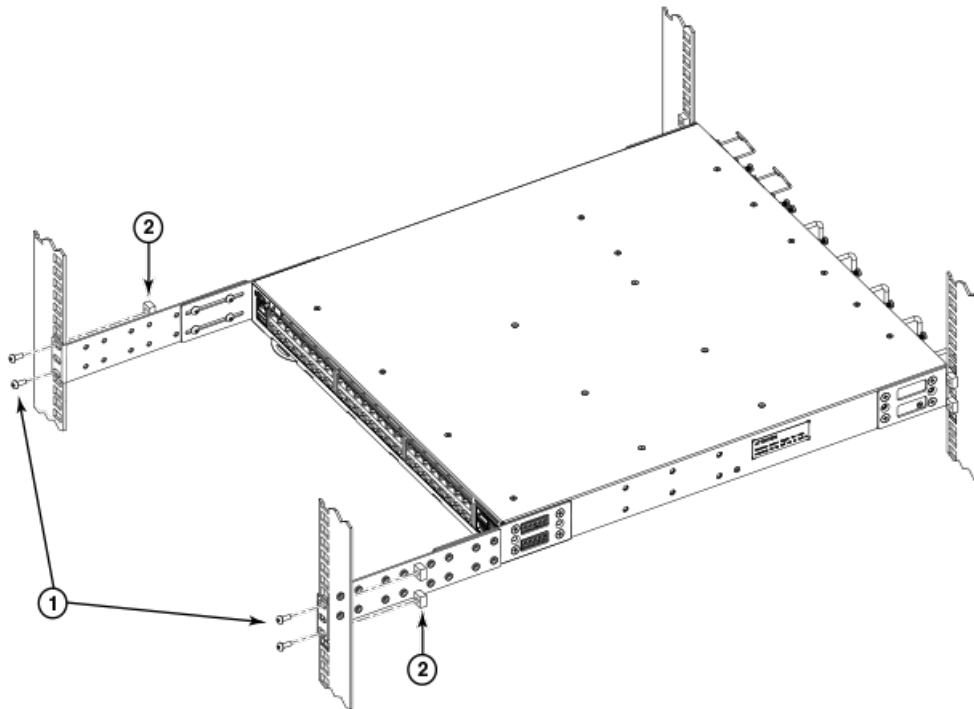

1. Screws, 10-32 x 5/8-in., panhead Phillips

2. Retainer nuts, 10-32

Installing the Universal Two-Post Rack Kit (XBR-R000294)

Use the following instructions to install an Extreme Networks 1U or 2U device in a two-post telecommunications (Telco) rack using the Universal Two-Post Rack Kit (XBR-R000294).

There are two ways you can mount the device in a two-post rack:

- With the port side flush with the front posts
- With the posts mounted to the mid-section of the device

Observe the following when mounting this device:

- Two people are required to install the device in a rack. One person should hold the device, while the other screws in the front and rear brackets
- Before mounting your device, review any specific installation and facility requirements in the Hardware Installation Guide for the device.
- Hardware devices illustrated in these procedures are only for reference and may not depict the device you are installing in the rack.

Time and items required

Allow 15 to 30 minutes to complete the installation.

The following items are required to install the device using the Universal Two-Post Rack Kit:

- #2 Phillips torque screwdriver
- 1/4-inch slotted-blade torque screwdriver

Parts list

The following parts are provided with the Universal Two-Post Rack Kit Installation (XBR-R000294).

FIGURE 53 Rack kit parts

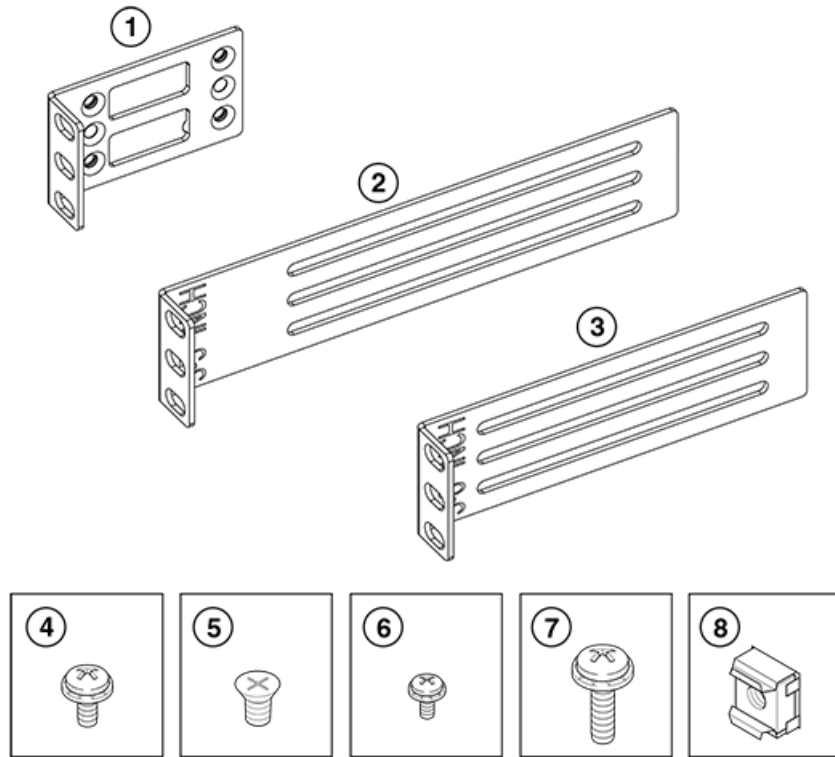

- | | |
|--|--|
| <ol style="list-style-type: none"> 1. Front brackets (2) 2. Rear brackets, 3-5 inch post (2) 3. Rear brackets, 5-6 inch post (2) 4. Screw, 8-32 x 5/16-in., panhead Phillips (8) | <ol style="list-style-type: none"> 5. Screw, 8-32 x 5/16-in., flathead Phillips (16) 6. Screw, 6-32 x 1/4-in., panhead Phillips (8) 7. Screw, 10-32 x 5/8-in., panhead Phillips (8) 8. Retainer nut, 10-32 (8) |
|--|--|

Ensure that the items listed and illustrated above are included in the kit. Note that not all parts may be used with certain installations depending on the device type.

Flush-front mounting

Observe the following notes when using this procedure:

- The device must be turned off and disconnected from the fabric during this procedure.
- The illustrations in this document show a 1U device, but the instructions are the same for a 2U device.
- The illustrations for this procedure show a two-post rack with narrow posts (3- to 5-inch) as an example.
- The illustrations in the rack installation procedures are for reference only and may not show the actual device.



CAUTION

Use the screws specified in the procedure. Using longer screws can damage the device.

Complete the following tasks to install the device in a rack:

1. [Attaching the front brackets to the device](#) on page 77
2. [Attaching the front brackets to the rack](#) on page 77

3. [Attaching the rear brackets to the rack](#) on page 78
4. [Attaching the rear brackets to the device](#) on page 79

Attaching the front brackets to the device

Complete the following steps to attach the front brackets to the device.

1. Position the right front bracket with the flat side against the right side of the device, as shown in [Figure 54](#).
2. Insert four 8-32 x 5/16-in. flathead screws through the vertically aligned holes in the bracket and then into the holes on the side of the device. Use the upper and lower screw holes, leaving the center holes empty.
3. Repeat step 1 and step 2 to attach the left front bracket to the left side of the device.
4. Tighten all the 8-32 x 5/16-in. screws to a torque of 15 in-lb (17 cm-kg).

FIGURE 54 Attaching the front brackets

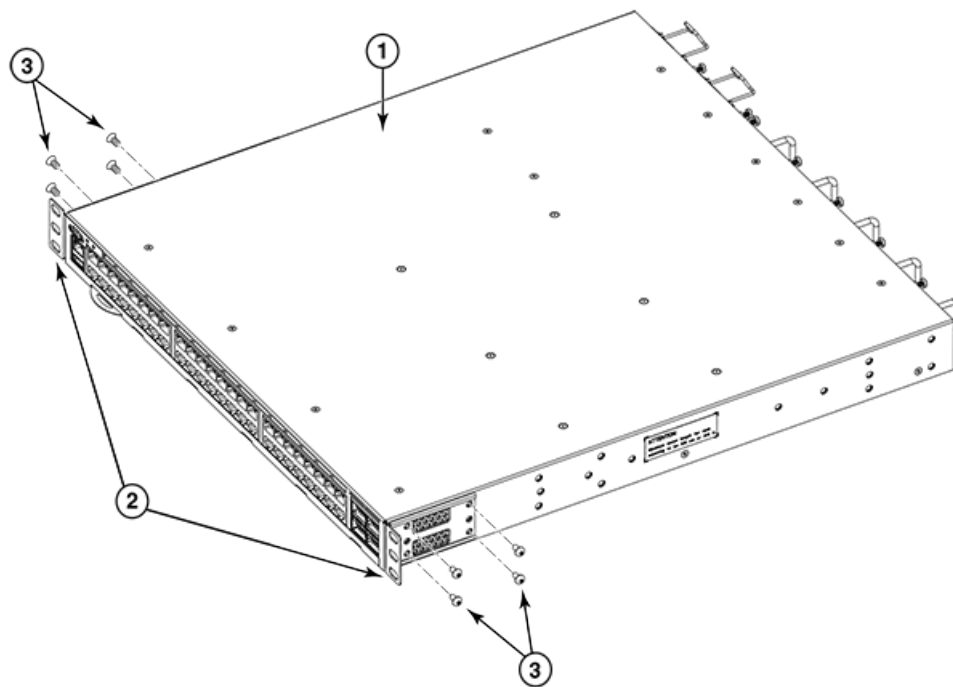

- | | |
|--|---|
| <ol style="list-style-type: none"> 1. The Extreme device 2. Front brackets, right and left | <ol style="list-style-type: none"> 3. Screws, 8-32 x 5/16-in., flathead Phillips |
|--|---|

Attaching the front brackets to the rack

Complete the following steps to install the device in the rack.

1. Position the device in the rack, as shown in [Figure 55](#), providing temporary support under the device until the rack kit is fully secured to the rack.
2. Attach the right front bracket to the right rack upright using two 10-32 x 5/8-in. panhead screws and two retainer nuts. Use the upper and lower holes in the bracket.

3. Attach the left front bracket to the left rack upright using two 10-32 x 5/8-in. panhead screws and two retainer nuts. Use the upper and lower holes in the bracket.
4. Tighten all the 10-32 x 5/8-in. screws to a torque of 25 in-lb. (29 cm-kg).

FIGURE 55 Attaching front brackets to a rack

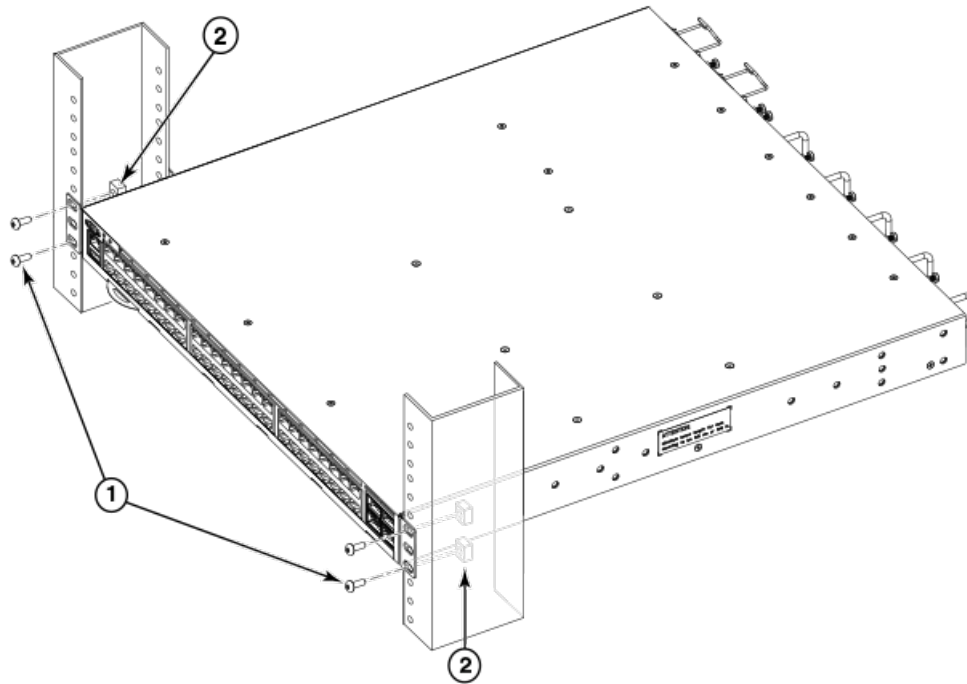

1. Screws, 10-32 x 5/8-in., panhead Phillips

2. Retainer nuts, 10-32

Attaching the rear brackets to the rack

Complete the following steps to attach the rear brackets to the rack.

1. Select the proper length bracket for your post width. If your posts are three to five inches wide, use the brackets marked 3-5 INCH. If your posts are five to six inches wide, use the brackets marked 5-6 INCH.
2. Position the right rear bracket in the right rear of the device, as shown in [Figure 56](#).
3. Attach the bracket to the right rack upright using two 10-32 x 5/8-in. panhead screws and two retainer nuts. Use the upper and lower holes in the bracket.
4. Repeat step 2 and step 3 to attach the left rear bracket to the left rack upright.

- Tighten all the 10-32 x 5/8-in. screws to a torque of 25 in-lb. (29 cm-kg).

FIGURE 56 Attaching the rear brackets to a rack

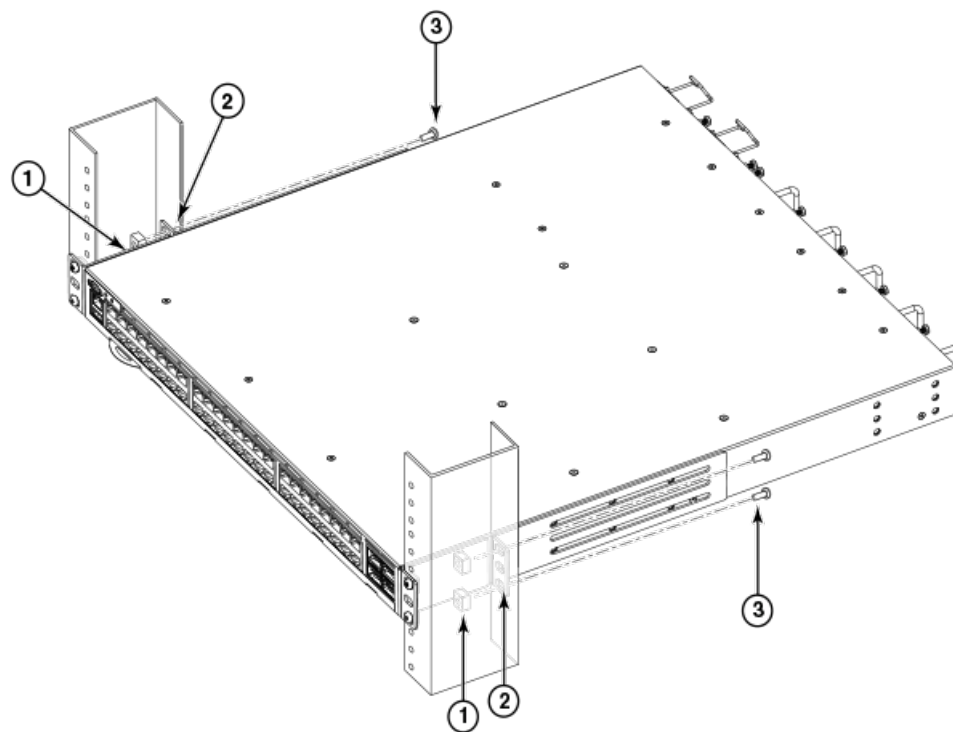

- Retainer nuts, 10-32
- Rear brackets

- Screws, 10-32 x 5/8-in., panhead Phillips

Attaching the rear brackets to the device

Complete the following steps to attach the rear brackets to the device.

- Align the right rear bracket to the right rear of the device and use four 8-32 x 5/16-in. panhead screws to attach the bracket to the device, as shown in [Figure 57](#). Be sure to insert the screws through the upper and lower slots in the bracket.
- Align the left rear bracket to the left rear of the device and use four 8-32 x 5/16-in. panhead screws to attach the bracket to the device. Again, use the upper and lower slots in the bracket.

3. Tighten all the 8-32 x 5/16-in. screws to a torque of 15 in-lb (17 cm-kg).

FIGURE 57 Attaching the rear brackets to the device

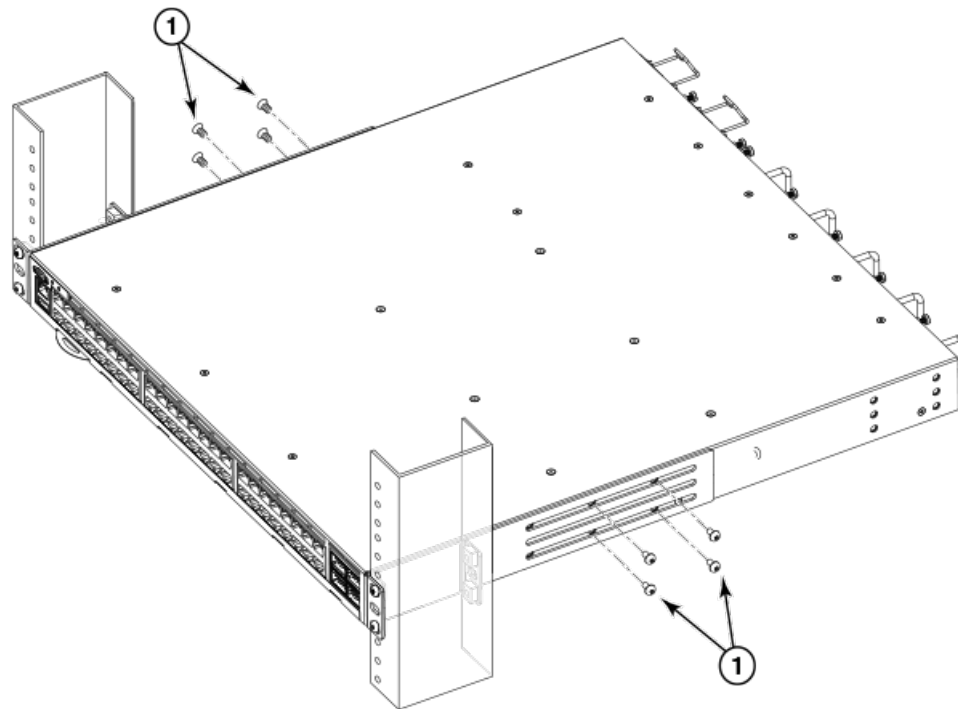

1. Screws, 8-32 x 5/16-in., panhead Phillips

Mid-mounting

Observe the following notes when using this procedure:

- The device must be turned off and disconnected from the fabric during this procedure.
- The illustrations in this document show a 1U device, but the instructions are the same for a 2U device.
- The illustrations in the rack installation procedures are for reference only and may not show the actual device.

Complete the following tasks to install the device in a rack:

1. [Attaching the front brackets to the device](#) on page 80
2. [Attaching the front brackets to the rack](#) on page 81
3. [Attaching the rear brackets to the rack](#) on page 82
4. [Attaching the rear brackets to the device](#) on page 83

Attaching the front brackets to the device

Complete the following steps to attach the front brackets to the device.

1. Position the right front bracket with the flat side against the right side of the device, as shown in [Figure 58](#).

2. Insert four 8-32 x 5/16-in. flathead screws through the vertically aligned holes in the bracket and then into the holes on the side of the device. Use the upper and lower screw holes, leaving the center holes empty.
3. Repeat step 1 and step 2 to attach the left front bracket to the left side of the device.
4. Tighten all the 8-32 x 5/16-in. screws to a torque of 15 in-lb (17 cm-kg).

FIGURE 58 Attaching the front brackets

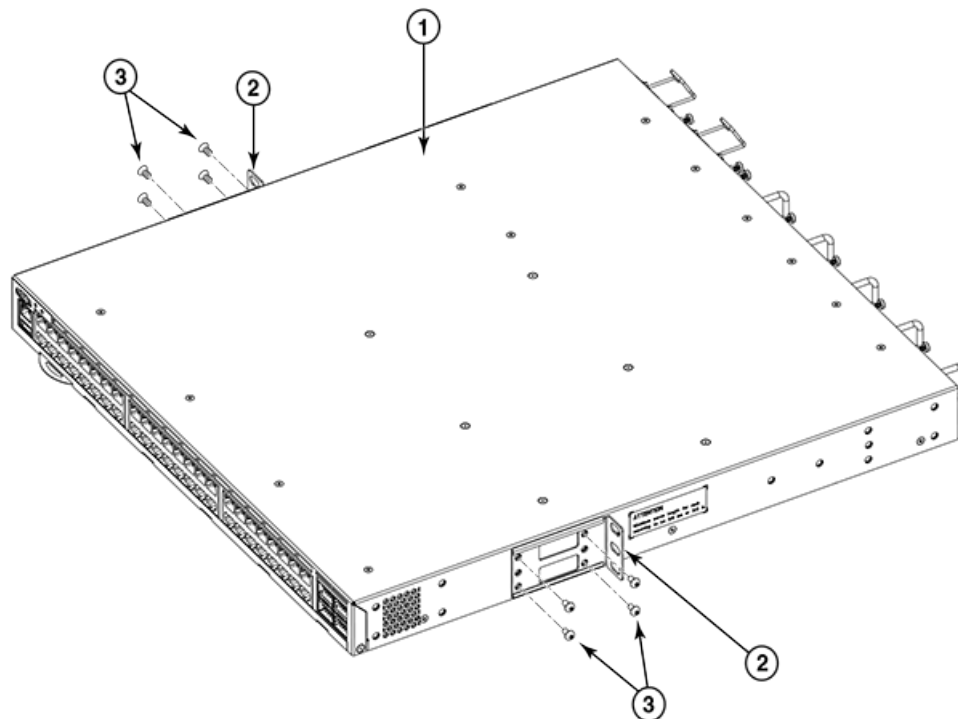

- | | |
|--|---|
| <ol style="list-style-type: none"> 1. The Extreme device 2. Front brackets, right and left | <ol style="list-style-type: none"> 3. Screws, 8-32 x 5/16-in., flathead Phillips |
|--|---|

Attaching the front brackets to the rack

Complete the following steps to install the device in the rack.

1. Position the device in the rack, as shown in [Figure 59](#), providing temporary support under the device until the rack kit is fully secured to the rack.
2. Attach the right front bracket to the right rack upright using two 10-32 x 5/8-in. screws and two retainer nuts. Use the upper and lower holes in the bracket.
3. Attach the left front bracket to the left rack upright using two 10-32 x 5/8-in. screws and two retainer nuts. Use the upper and lower holes in the bracket.

4. Tighten all the 10-32 x 5/8-in. screws to a torque of 25 in-lb (29 cm-kg).

FIGURE 59 Attaching front brackets to a rack

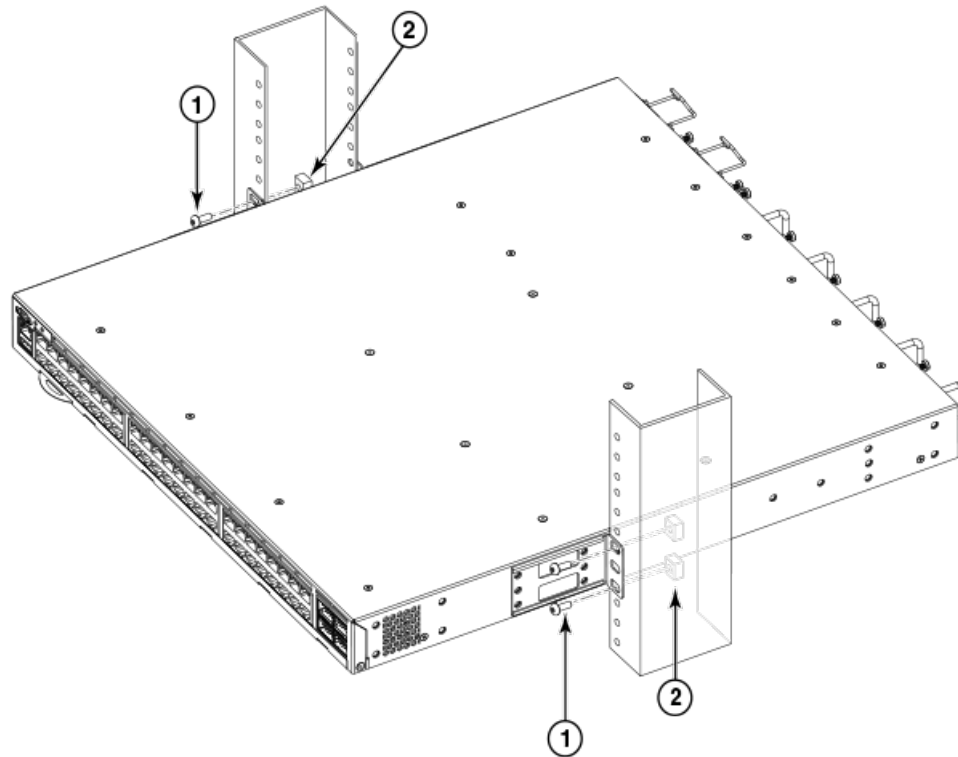

1. Screws, 10-32 x 5/8-in., panhead Phillips

2. Retainer nuts, 10-32

Attaching the rear brackets to the rack

Complete the following steps to attach the rear brackets to the rack.

1. Select the proper length bracket for your post width. If your posts are three to five inches wide, use the brackets marked 3-5 INCH. If your posts are five to six inches wide, use the brackets marked 5-6 INCH.
2. Position the right rear bracket in the right rear of the device, as shown in the following figure. Whether you are using the 3-5 inch or the 5-6 inch bracket, the rear end of the bracket will be flush with the back of the device.
3. Attach the brackets to the right rack upright using two 10-32 x 5/8-in. panhead screws and two retainer nuts.
4. Repeat step 2 and step 3 to attach the left rear bracket to the left rack upright.

5. Tighten all the 10-32 x 5/8-in. screws to a torque of 25 in-lb (29 cm-kg).

FIGURE 60 Attaching the rear brackets to a rack

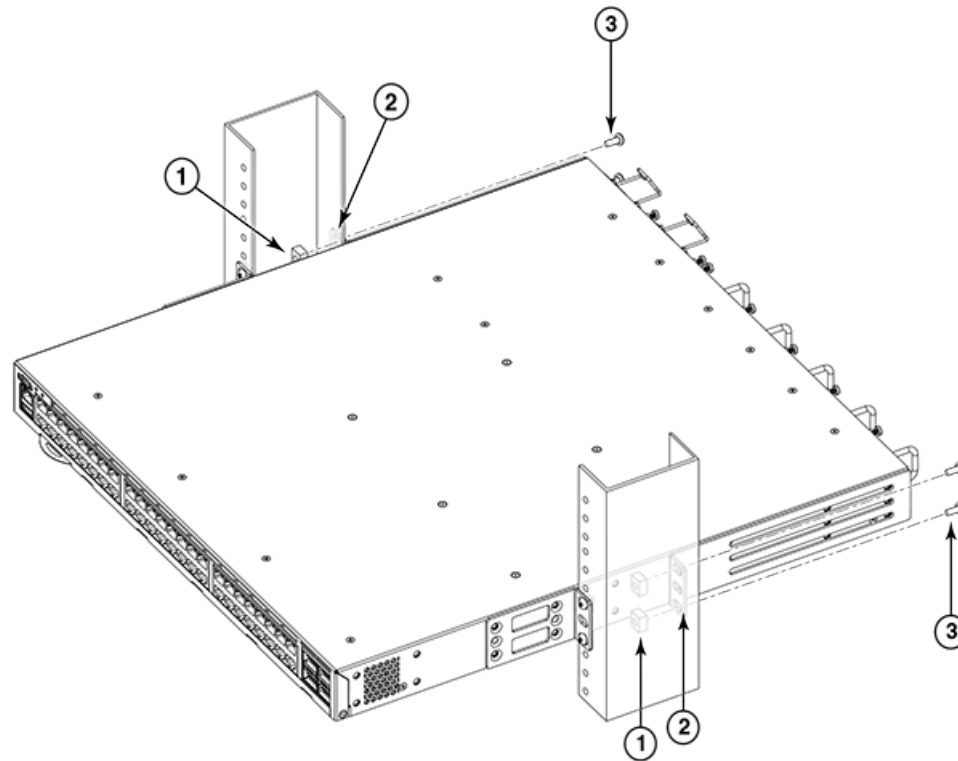

1. Retainer nuts, 10-32
2. Rear brackets (right and left)

3. Screws, 10-32 x 5/8-in., panhead Phillips

Attaching the rear brackets to the device

Complete the following steps to attach the rear brackets to the device.

1. Align the right rear bracket to the right rear of the device and use four 8-32 x 5/16-in. panhead screws to attach the bracket to the device, as shown in [Figure 61](#). Be sure to insert the screws through the upper and lower slots in the bracket.
2. Align the left rear bracket to the left rear of the device and use four 8-32 x 5/16-in. panhead screws to attach the bracket to the device. Again, use the upper and lower slots in the bracket.

3. Tighten all the 8-32 x 5/16-in. screws to a torque of 15 in-lb (17 cm-kg).

FIGURE 61 Attaching the rear brackets to the device

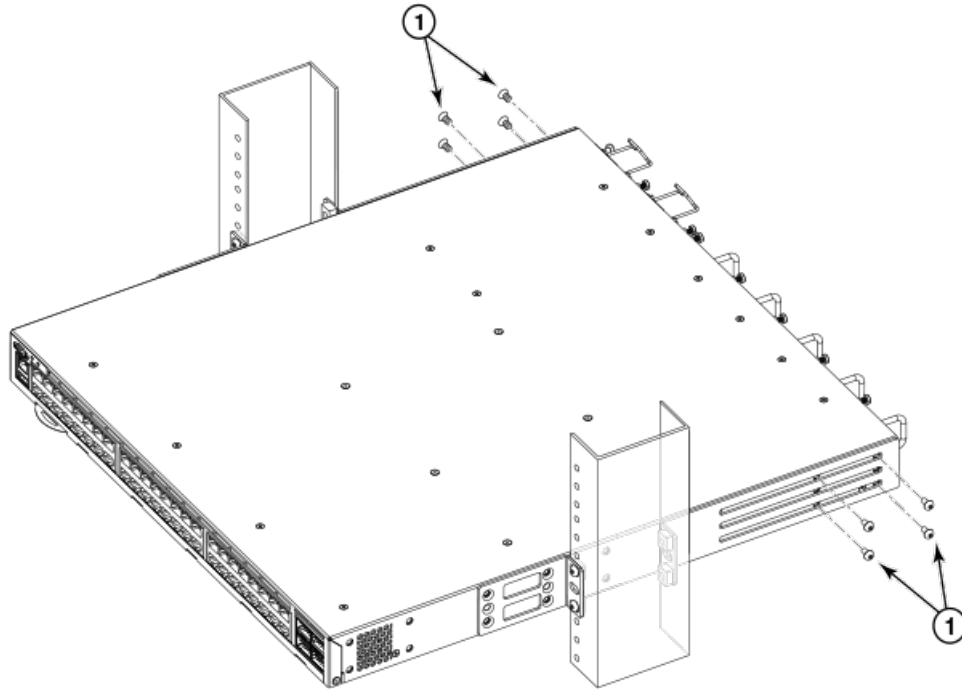

1. Screws, 8-32 x 5/16-in., panhead Phillips

Initial Configuration

• Configuration overview.....	85
• Items required.....	86
• Providing power to the device.....	86
• Verifying operation.....	89
• Establishing a serial connection.....	89
• Assigning permanent passwords	90
• Configuring the device IP address.....	91
• Setting the date and time	93
• Changing the RBridge ID and VCS ID.....	95
• Network device connections.....	95
• Upgrading port speeds on the VDX 6740T.....	96

Configuration overview

- IP address and gateway address for the device
- IP addresses, host names, and gateway addresses for one or two management modules, as needed
- Passwords - You may need to change passwords from their default values and set the time and date, either by the way of NTP or manually.

Upon bootup, the device attempts to form ISLs with connected devices. If the device is not connected to another device, it forms a "single node VCS fabric." This means that the chassis operates as a standalone system, but the operational mode is always VCS-enabled.

In VCS mode, the device can be part of an Ethernet fabric involving two or more VCS-enabled devices. VCS technology embodies the concepts of distributed intelligence and logical chassis. Distributed intelligence means that all configuration and destination information is automatically distributed to each member in the fabric. Distributed intelligence has three major characteristics:

- The fabric is self-forming. When two VCS-enabled devices are connected, the fabric is automatically created and the devices discover the common fabric configuration.
- The fabric is masterless. No single device stores configuration information or controls fabric operations. Any device can fail or be removed without causing disruptive fabric downtime or delayed traffic.
- The fabric is aware of all members, devices, and Virtual Machines (VMs). Automatic Migration of Port Profiles (AMPP) supports VM migration to another physical server. If the VM moves, it is automatically reconnected to all of its original resources.

Logical chassis means that the entire VCS fabric appears and can be managed as a single Layer 2 device. There are three major characteristics to logical chassis:

- Each physical device in the fabric can be managed as if it were a blade in a chassis. When a VCS-enabled device is connected to the fabric, it inherits the configuration of the fabric and the new ports become available immediately.
- You can manage the entire fabric from any device.
- You can manage the edge devices in the fabric as if they were a single device.

In Extreme Network OS v7.1.0 and later, all configuration changes are maintained in the running configuration after a reboot. For prior releases, for nodes in fabric cluster mode only, you must copy the running configuration file to the startup configuration using the **copy running-config startup-config** command to ensure that the device reboots with the preferred configuration.

The device can be deployed as part of a VCS and IP fabrics. For advanced procedures to configure the device for VCS and IP fabrics, refer to the *etwork OS Management Configuration Guide*, *Extreme Network OS IP Fabrics Configuration Guide*, and the *Extreme Network OS Command Reference*.

Items required

The following items are required for initial setup and verification of the device:

- The device, mounted and installed with the required power supply and fan assemblies, transceivers, and cables; and connected to a power source
- A workstation computer with a terminal emulator application installed, such as HyperTerminal for Windows
- An unused IP address with corresponding subnet mask and gateway address
- A serial cable with an RJ-45 connector
- RJ-45 to DB-9 adapter
- An Ethernet cable
- Access to an FTP server or USB device for backing up (uploading) or downloading the device configuration (optional)

Providing power to the device

Perform the following steps to provide power to the device.

1. Connect the power cords to both power supplies, and then to power sources on separate circuits to protect against failure. Ensure that the power cords have a minimum service loop of 15.2 cm (6 in.) available and are routed to avoid stress.
2. For the VDX 6740, flip the switch on each power supply to I.

For the VDX 6740T, the power supplies power up as soon as they are plugged in.

The power supply LEDs display green. The power LED on the front of the device turns green as well. The system status LED on the front panel will be amber until POST completes and then it will turn green.

NOTE

Power is supplied to the device as soon as the first power supply is connected and powered on.

3. After POST is complete, verify that the device power and status LEDs on the port side of the device are green.

Connecting an AC power cord

Use the supplied power cords. Ensure the facility power receptacle is the correct type, supplies the required voltage, and is properly grounded.

Perform the following steps to connect to AC power:

1. Connect the power cords to both power supplies.
2. Route the cords so they will be out of the way when connected to the power source. Ensure that the power cords have a minimum service loop of 15.2 cm (6 in.) available and are routed to avoid stress.

- Plug the other end of the cable into a power source on separate circuits to protect against failure. The power supplies power up as soon as they are plugged in.

NOTE

Power is supplied to the device as soon as the first power supply is connected and powered on.

Connecting a power cord to a 500W DC power supply

Use the following steps to connect DC power cords to 500W DC power supplies.

- Remove the DC wiring assembly from the front of each DC power supply by loosening the two assembly screws.

FIGURE 62 DC wiring assembly and power source wires

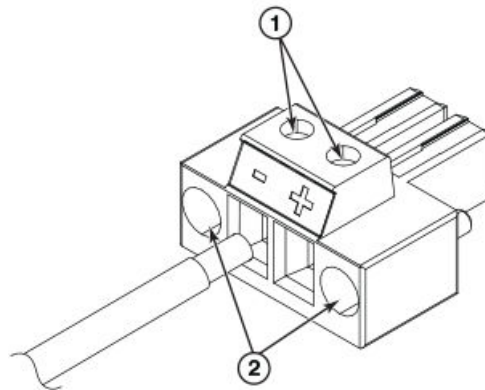

1. Wire tightening screws

2. Assembly screws

- Loosen the wire tightening screws and insert wires from the DC power source into the wiring assembly. Connect the -48V source cable to the negative terminal and the 0V cable to the positive terminal as marked on the harness assembly.
- Tighten the wire tightening screws and reinstall the wiring assembly onto the power supply.
- Tighten the assembly screws on the wiring assembly to secure it to the power supply.
- Connect the wires from the power supply wiring assembly to your DC power source.

NOTE

The equipment installation must meet NEC/CEC code requirements. Consult local authorities for regulations.

- Ground the chassis by attaching the ground wire from building ground to an appropriate crimp connector and attaching the connector to a ground lug attaching screw located on the leftmost side of the nonport side of the device.

**CAUTION**

For a DC system, use a grounding wire of at least 12 American Wire Gauge (AWG). The 12 AWG wire should be attached to an agency-approved crimp connector crimped with the proper tool.

NOTE

To ensure adequate bonding when attaching the ground lug, a minimum of 20 in-lb (2.76 Nm) of torque is required to be applied to the mounting hardware used to attach the ground lug.

7. Refer to "Power Precautions."
8. Follow these additional precautions when making connections to DC power supplies:

NOTE

The equipment installation must meet NEC/CEC code requirements. Consult local authorities for regulations.



CAUTION

For the DC input circuit to the system, make sure there is a 20 Amp circuit breaker, minimum -48 VDC, double pole, on the input terminal block to the power supply. The input wiring for connection to the product should be copper wire, 12 AWG, marked VW-1, and rated minimum 90°C.



CAUTION

DC return shall be isolated from the chassis ground (DC-I) when connections to the power supply are made.

Connecting a DC power cord to a 250W DC power supply

Use the following steps to connect DC power cords to 250W DC power supplies.

1. Remove the DC wiring assembly from the front of each DC power supply by loosening the two assembly screws.

FIGURE 63 The DC wiring assembly

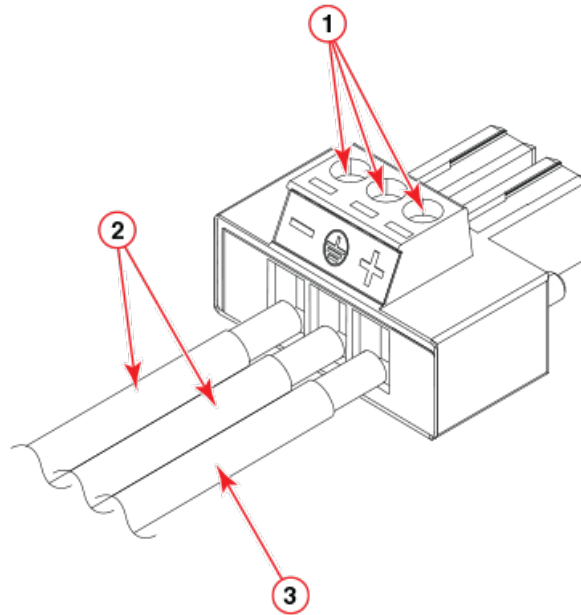

1	Wire tightening screws	2	DC power source wires
3	Earth ground wire		

2. Loosen the wire tightening screws and insert wires from the DC power source into the wiring assembly. Connect the -48V source cable to the negative terminal and the 0V cable to the positive terminal as marked on the harness assembly.
3. Tighten the wire tightening screws and reinstall the wiring assembly onto the power supply.
4. Tighten the assembly screws on the wiring assembly to secure it to the power supply.
5. Connect the wires from the power supply wiring assembly to your DC power source.

6. Refer to "Power Precautions."
7. Follow these additional precautions when making connections to DC power supplies:

NOTE

The equipment installation must meet NEC/CEC code requirements. Consult local authorities for regulations.

**CAUTION**

For the DC input circuit to the system, make sure there is a 10 Amp circuit breaker, maximum 60 VDC, double pole, on the input terminal block to the power supply. The input wiring for connection to the product should be copper wire, 16 AWG, marked VW-1, and rated minimum 90°C.

**CAUTION**

DC return shall be isolated from the chassis ground (DC-I) when connections to the power supply are made.

**CAUTION**

For a DC system, use grounding wire of at least 16 American Wire Gauge (AWG). The grounding wire should be attached to the DC input connector; the other end connects to the building ground.

Verifying operation

Power is supplied to the device as soon as the first power supply is connected and powered on. During POST activities, the system status LED on the port-side of the device displays amber and the port LEDs illuminate.

After the system powers on and POST completes, verify the following:

1. Verify that the power supply LEDs are solid green. Refer to the "LED Locations" section of this guide for the location of these LEDs.
2. Verify that the system power LED and the system status LED is solid green. Refer to the "LED Locations" section of this guide for the location of these LEDs.
3. When POST is complete, only the LEDs for ports connected to other devices should be green. Refer to the "LED Locations" section of this guide for the location of these LEDs.

Refer to the appropriate "LED Patterns" section of this guide for the meaning of LED displays.

Establishing a serial connection

Perform all configuration tasks in this guide using a serial connection from a workstation or terminal. The serial port can be used to connect to a workstation to configure the IP address for the device before connecting it to a fabric or IP network.

Complete the following steps to create a serial connection to the device.

1. Connect the serial cable to the serial port on the device and to an RS-232 serial port on the workstation or terminal device.

If the serial port on the workstation or terminal device is RJ-45 instead of RS-232, remove the adapter on the end of the serial cable and insert the exposed RJ-45 connector into the RJ-45 serial port on the workstation.

2. Open a terminal emulator application (such as HyperTerminal on a PC, or TERM, TIP, or Kermit in a UNIX environment), and configure the application as follows:
 - In a Windows environment, enter the following values: 9600 bits per second, 8 databits, no parity, 1 stop bit, and no flow control.

NOTE

Flow control is not supported on the serial consoles when attached to remote terminal servers and must be disabled on the customer-side remote terminal server and the host-side clients.

- In a UNIX environment using TIP, enter the following string at the prompt:

```
tip /dev/ttyb -9600
```

If ttyb is already in use, use ttya instead.

The serial port is located on the port side of the chassis. The VDX 6740 uses an RJ-45 connector for the serial port. The VDX 6740T uses a mini-USB connector for the serial port. An RJ-45 to DB9 adapter is also provided with each model. The cable supplied is a rollover cable.

**CAUTION**

To protect the serial port from damage, keep the cover on the port when not in use.

Refer to the product Technical Specifications for a listing of serial cable pinouts.

Assigning permanent passwords

When you log in for the first time, Extreme Networks recommends that you change the passwords for the default accounts.

The factory-configured default accounts are admin, user, and root. Use the default administrative account as shown in the following table to log in to the device for the first time and to perform the basic configuration tasks.

The root account, disabled by default, is reserved for development and manufacturing. The user account is read-only and used primarily for system monitoring.

TABLE 2 Default administrative account names and passwords

Account type	Login name	Password
Administrative	admin	password
User account (read-only)	user	password

Changing the default account passwords

When you change the default account password after you log in for the first time, only the default password rule is in effect. The rule specifies a minimum password length of eight characters. For advanced user and role management, including setting password rules, refer to the *Extreme Network OS Security Configuration Guide*.

1. Enter the **configure terminal** command to enter global configuration mode.
2. Enter the **username** command followed by the account name and the password parameter.

3. When prompted, enter the new password. and press **Enter** .

```
device# configure terminal
Entering configuration mode terminal
device(config)# username admin password
(<WORD>;User password satisfying password-attributes):*****
```

Configuring the device IP address

You can configure this device with a static IP address, or you can use a Dynamic Host Configuration Protocol (DHCP) server to set the device IP address. DHCP is enabled by default. Devices support both IPv4 and IPv6 format addresses.

Using DHCP to set the IP address

When using DHCP, the Extreme Networks devices obtain the IP address, subnet mask, and default gateway address from the DHCP server. The DHCP client can only connect to a DHCP server that is on the same subnet as the device. If your DHCP server is not on the same subnet as the Extreme Networks device, use a static IP address.

To set an IPv4 IP address using DHCP, complete the following steps.

1. Log in to the device using the admin account.
2. Configure the management interface with the following command:

```
device(config)# interface Management 1/0
```

3. Configure the IP address using the following command:

```
device(config-Management-1/0)# ip address dhcp
```

Setting a static IP address

Complete the following steps to set a static IP address.

1. Log in to the device using the default password (the default password is **password**).

2. Use the **ip address** command to set the Ethernet IP address.

If you are going to use an IPv4 IP address, enter the IP address in dotted decimal notation. You should also disable DHCP and enter a gateway address as well.

```
device(config)# interface Management 1/0
device(config-Management-1/0)# no ip address dhcp
device(config-Management-1/0)# ip address 10.24.85.81/20
```

To set up a default gateway, add an IP route in RBridge mode.

```
device(config-rbridge-id-10)# vrf mgmt-vrf
device (config-vrf-mgmt-vrf)# address-family ipv4 unicast
device (vrf-ipv4-unicast)# ip route 0.0.0.0/0 10.24.80.1
device (vrf-ipv4-unicast)# exit
device (config-vrf-mgmt-vrf)# exit
```

If you are going to use an IPv6 address, enter the network information in semicolon-separated notation as prompted after the **ipv6 address** operand.

```
device(config)# interface Management 1/0
device(config-Management-1/0)# no ip address dhcp
device(config-Management-1/0)# ipv6 address \
fd00;60;69bc;832;e61f;13ff;fe67;4b94/64
```

3. To display the configuration, use the **show running-config interface Management** command.

```
device# show running-config interface Management 1/0
interface Management 1/0
no ip address dhcp
ip address 10.24.85.81/20
ipv6 address fd00;60;69bc;832;e61f;13ff;fe67;4b94/64
no ipv6 address autoconfig
!
```

Stateless IPv6 autoconfiguration

IPv6 allows assignment of multiple IP addresses to each network interface. Each interface is configured with a link local address in almost all cases, but this address is only accessible from other hosts on the same network. To provide for wider accessibility, interfaces are typically configured with at least one additional global scope IPv6 address. IPv6 autoconfiguration allows more IPv6 addresses, the number of which is dependent on the number of routers serving the local network and the number of prefixes they advertise.

When IPv6 autoconfiguration is enabled, the platform will engage in stateless IPv6 autoconfiguration. When IPv6 autoconfiguration is disabled, the platform will relinquish usage of any autoconfigured IPv6 addresses that it may have acquired while IPv6 autoconfiguration was enabled. This same enabled or disabled state also enables or disables the usage of a link local address for each managed entity (though a link local address will continue to be generated for each device) because those link local addresses are required for router discovery.

The enabled or disabled state of autoconfiguration does not affect any static IPv6 addresses that may have been configured. Stateless IPv6 autoconfiguration and static IPv6 addresses can coexist.

Setting stateless IPv6 autoconfiguration

To configure stateless IPv6 autoconfiguration, complete the following steps.

1. Enter the **configure terminal** command to enter global configuration mode.

2. Take the appropriate action based on whether you want to enable or disable IPv6 autoconfiguration:
 - Enter the **ipv6 address autoconfig** command to enable IPv6 autoconfiguration for all managed entities on the target platform.
 - Enter the **no ipv6 address autoconfig** command to disable IPv6 autoconfiguration for all managed entities on the target platform.

Setting the date and time

Extreme Networks devices maintain the current date and time inside a real-time clock (RTC) circuit. Date and time are used for logging events. The device does not depend on the date and time for its operation; even with an incorrect date and time value, the device functions properly. However, because the date and time are used for logging, error detection, and troubleshooting, you should set them correctly.

Time zones

You can set the time zone for the device by using the **clock timezone** command. The time zone setting has the following characteristics:

- The **clock timezone** setting automatically adjusts for Daylight Savings Time.
- Changing the time zone on a device updates the local time zone setup and is reflected in local time calculations.
- By default, all devices are in the Greenwich Mean Time (GMT) time zone (0,0). If all devices in a fabric are in one time zone, it is possible for you to keep the time zone setup at the default setting.
- System services that have already started will reflect the time zone changes only after the next reboot.
- Time zone settings persist across failover for high availability.
- Time zone settings are not affected by Network Time Protocol (NTP) server synchronization.

The following regions are supported: Africa, America, Antarctica, Asia, Atlantic, Australia, Europe, Indian, and Pacific. One of these, along with a city name, establishes the time zone.

Time synchronization

To keep the time in your network current, it is recommended that the principal switch has its time synchronized with at least one external NTP server. The other devices in the fabric will automatically take their time from the principal switch.

All devices in the fabric maintain the current clock server value in nonvolatile memory. By default, this value is the local clock server of the principal switch. Changes to the clock server value on the principal switch are propagated to all switches in the fabric.

When a new device enters the fabric, the time server daemon of the principal switch sends out the addresses of all existing clock servers and the time to the new device.

The **ntp server** command accepts multiple server addresses in IPv4 format. When multiple NTP server addresses are passed, **ntp server** sets the first obtainable address as the active NTP server. If there are no reachable time servers, then the local time is the default time.

Synchronizing local time using NTP

Perform the following steps to synchronize the local time using NTP.

1. Log in to the device using the admin account (the default password is **password**).

2. Enter **configure terminal** to change to global configuration mode

```
device# configure terminal
Entering configuration mode terminal
```

3. Enter the **ntp server IPv4 address** command, where *IPv4 address* is the IP address of the first NTP server in IPv4 format, which the device must be able to access. The *IPv4 address* variable is optional. By default, this value is LOCL, which uses the local clock of the principal switch as the clock server.

```
device(config)# ntp server "132.163.135.131"
```

To display the NTP server IP address, use the **show ntp status rbridge-id rbridge-id|all** command. If you are in global configuration mode, you must enter **do** before the **show** command.

```
device(config)# show ntp status rbridge-id 1
```

The request is for the local RBridge unless an RBridge ID is specified.

If you need to remove an NTP server, use the **no** form of the **ntp server** command.

```
device(config)# no ntp server "132.163.135.131"
```

Setting the clock (date and time) manually

You should set the clock only if there are no NTP servers configured. Time synchronization from NTP servers overrides the local clock. Date values are limited to between January 1, 1970 and January 19, 2038.

1. Log in to the device using the admin account.
2. Enter the **clock set CCYY-MM-DDTHH:MM:SS** command while in privileged EXEC mode.

The following example sets the clock to March 17, 2010, 15 minutes past noon:

```
device# clock set 2010-03-17T12:15:00
```

3. To show the clock and time zone settings, use the **show clock rbridge-id rbridge-id|all** command.

```
device# show clock
rbridge-id 1: 2012-03-17 12:15:00 America/Los_Angeles
```

Setting the time zone

You must perform this procedure on *all* devices for which the time zone must be set. However, you only need to set the time zone once on each device, because the value is written to nonvolatile memory. While not necessary for device operation, setting a time zone is part of ensuring accurate logging and audit tracking. Time zone changes take effect after a reboot.

Use the **clock timezone** command to set the time zone.

1. Log into the device using an account that has the admin role.
2. Enter the **clock timezone region/city** command.

The following example changes the time zone to US/Pacific Standard Time:

```
device# clock timezone America/Los_Angeles
```

3. Reboot the device.

Changing the RBridge ID and VCS ID

If you are planning to connect more than one device in a fabric, each device must have a unique RBridge ID. The default RBridge ID for the device is 1.

If you are planning more than one VCS fabric, each fabric must have a unique VCS ID. The default VCS ID is 1.

If you need to change an Rbridge ID or VCS ID, you can use either of the following commands:

- **vcs set-rbridge-id**: This changes the existing RBridge ID of a node. An option is available for this command to also change the VCS ID.
- **vcs vcsid**: This changes the existing VCS ID of a node. An option is available for this command to also change the RBridge ID.

NOTE

Each time that you change the Extreme Networks VCS Fabric configuration, the device resets to the default configuration and reboot automatically. Make sure to save the configuration before using either of these commands.

For details on using these commands, refer to the *Extreme Network OS Command Reference* and *Extreme Network OS Management Configuration Guide*.

Network device connections

Refer to the product Technical Specifications for a listing of supported cables.



CAUTION

Before plugging a cable into any port, be sure to discharge the voltage stored on the cable by touching the electrical contacts to ground surface.

Ethernet or Fast Ethernet hubs

For copper connections to Ethernet hubs, a 1000Base-T device, or another Extreme Networks device, a crossover cable is required. If the hub is equipped with an uplink port, it requires a straight-through cable instead of a crossover cable.

NOTE

The 802.3ab standard (automatic MDI or MDIX detection) calls for automatic negotiation of the connection between two 1000Base-T ports. Therefore, a crossover cable may not be required; a straight-through cable may work as well.

Workstations, servers, or routers

Straight-through UTP cabling is required for direct UTP attachment to workstations, servers, or routers using network interface cards (NICs).

Fiber cabling is required for direct attachment to Gigabit NICs or switches and routers through fiber ports.

Network device

For direct attachment from the Extreme Networks device to a Gigabit NIC, switch, or router, you can use either a fiber cabling with an LC connector or a copper cable with an RJ-45 connector.

Testing connectivity

After you install the network cables, you can test network connectivity to other devices by observing the LEDs related to network connection and performing trace routes. Refer to the LED patterns section of this guide for a description of the port states.

Upgrading port speeds on the VDX 6740T

Using the 10G Port Upgrade License, you can enable RJ45 ports operating at 1 Gbps on the VDX 6740T to also operate at 10 Gbps. The license is applied in increments of 16 ports. To upgrade the ports, use the following procedure. This information applies to the VDX 6740T-1G variant.

1. Install the PORT_10G_UPGRADE license. Use the following instructions in the Administering Licenses chapter of the *Extreme Network OS Software Licensing Guide*:
 - Displaying the switch license ID
 - Obtaining the license key
 - Installing a license
2. Enter the **show dpod** command to verify the allowed reservation pool size and to determine 10G ports that are assigned to a 10G Port Upgrade license already.

```
device# show dpod
```

3. Enter the **configure terminal** command to access global configuration mode

```
device# configure terminal
```

4. Enter the **shutdown** command for the interface if not already in shutdown state.

```
device(config)# interface gigabitethernet 1/0/1
device(conf-if-gi-1/0/1)# shutdown
```

5. Enter the **dpod** command while in global configuration mode to reserve a license assignment for the port from the license pool.

```
device(config)dpod 1/0/1 reserve
```

NOTE

To remove a license assignment for a port, use **release** instead of **reserve**.

6. Perform one of the following steps:
 - Configure interface speed to 10000 using the **speed** command.

```
device(config)# interface tengigabitethernet 1/0/1
device(conf-if-int-1/0/1)# speed 10000
```

NOTE

This operation may fail as a result of limited available reservations.

- Configure the interface speed to **auto** to allow dynamic link speed selection up to 10 Gbps.

```
device(config)# interface tengigabitethernet 1/0/1
device(conf-if-int-1/0/1)# speed auto
```

7. Enable the 10G interface using the **no shutdown** command.

```
device(config)# interface tengigabitethernet 1/0/1
device(conf-if-te-1/0/1)# no shutdown
```

Operation and Maintenance

- LED activity interpretation..... 99
- POST and boot specifications..... 104
- Interpreting POST results..... 104
- Powering off the device..... 105
- Thermal operations..... 105
- Device maintenance..... 105
- Device management..... 108

LED activity interpretation

System activity and status can be determined through the activity of the LEDs on the device.

There are three possible LED states: off (no light), a steady light, and a flashing light. Flashing lights may be slow, fast, or flickering. The LED colors are either green or amber. Refer to [LED patterns](#) on page 101 for details on LED behavior.

Sometimes, the LEDs flash either of the colors during boot, POST, or other diagnostic tests. This is normal; it does not indicate a problem unless the LEDs do not indicate a healthy state after all boot processes and diagnostic tests are complete.

LEDs

The ExtremeSwitching VDX 6740 devices have the following LEDs:

- One bicolor system status LED (green and amber) on the port side.
- One power status LED (green) on the port side.
- Two Ethernet management port LEDs (green) for the Ethernet management port. The two LEDs show the status of the port link and the port activity.
- One triangle-shaped bicolor port status LED (green and amber) for each 10 GbE port. These LEDs are arrayed above each vertical port.
- One triangle-shaped bicolor port status LED (green and amber) for each 40 GbE port. These LEDs are arrayed between each vertical pair of 40 GbE ports. The left LED corresponds to the upper port of the pair and the right LED corresponds to the lower port.
- One power supply and fan assembly LED (green) above the AC or DC power switch on each combined power supply and fan assembly on the non-port side of the VDX 6740.
- One power supply LED (green) to the left of the AC or DC power plug on each power supply on the non-port side of the VDX 6740T.
- One bicolor fan status LED (green and amber) on each fan assembly on the non-port side of the VDX 6740T.

LED locations

On the VDX 6740, the port status LEDs for the external ports are situated between the upper and lower ports of each pair. On the VDX 6740T, the port status LEDs for the 10 GbE ports are situated above the upper and lower ports of each pair. The port status LEDs for the 40 GbE ports are situated between the upper and lower ports of each pair as on the VDX 6740. Refer to the following illustration.

NOTE

The FlexPort feature allows configuration of specific ports as Ethernet or Fibre Channel ports, depending on installed transceivers. Therefore, status LEDs may indicate GbE or FC port function. Refer to [FlexPort](#) on page 14 for more information.

FIGURE 64 LEDs on the port side of the VDX 6740

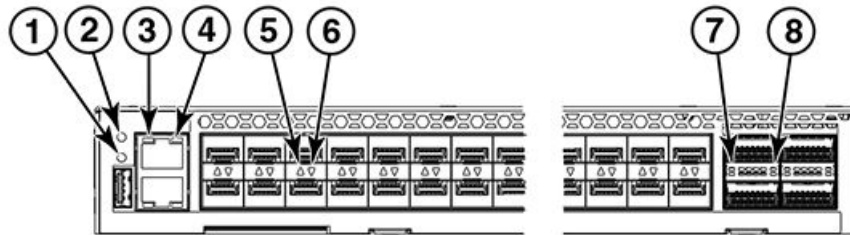

- | | |
|---|--|
| <ul style="list-style-type: none"> 1. System power LED 2. System status LED 3. Device management Ethernet port link LED 4. Device management Ethernet port activity LED | <ul style="list-style-type: none"> 5. Upper GbE SFP+ port status LED 6. Lower GbE SFP+ port status LED 7. Upper 40 GbE QSFP port status LED 8. Lower 40 GbE QSFP port status LED |
|---|--|

FIGURE 65 LEDs on the port side of the VDX 6740T

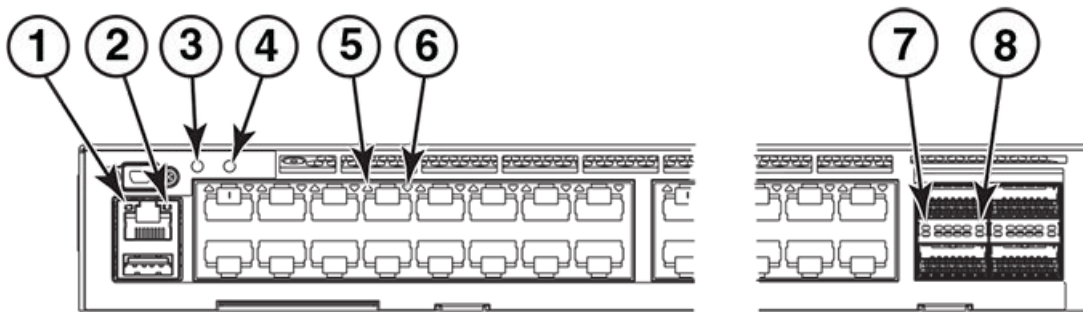

- | | |
|---|--|
| <ul style="list-style-type: none"> 1. Device management Ethernet port link LED 2. Device management Ethernet port activity LED 3. System status LED 4. System power LED | <ul style="list-style-type: none"> 5. Upper 10G Base-T port status LED* 6. Lower 10G Base-T port status LED* 7. Upper QSFP port status LED* 8. Lower QSFP port status LED* |
|---|--|

* Base ports on the VDX 6740T operate at 1 Gbps unless port upgrade license is applied to allow 10 Gbps.

The following illustration shows the LEDs on the non-port side of the VDX 6740T.

FIGURE 66 LEDs on the non-port side of the VDX 6740T

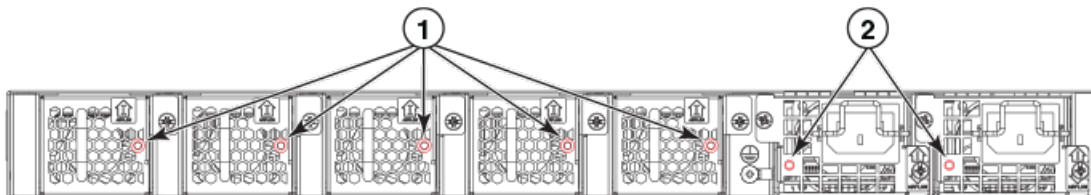

- | | |
|---|---|
| <ul style="list-style-type: none"> 1. Fan assembly status LEDs | <ul style="list-style-type: none"> 2. Power supply status LEDs |
|---|---|

LED patterns

The following table lists the port-side LEDs and the meaning of LED operation.

NOTE

For ports configured for FlexPort operation, LED patterns indicate operational status of GbE or Fibre Channel ports, depending on type of transceiver installed and FlexPort configuration of port.

TABLE 3 Port side LED patterns during normal operation

LED name	LED color	Status of hardware	Recommended action
System power (one LED [green])	Off (no light)	System is off or there is an internal power supply failure. Voltage may be dropping below specification.	Verify the system is powered on, the power cables are attached, and your power source is live. Contact your service provider.
	Steady green	System is on and power supplies are functioning properly.	No action required.
System status (one bicolor LED [green and amber])	Off (no light)	System is off or there is no power.	Verify the system is on.
	Steady green	System is on and functioning properly.	No action required.
	Blinking amber/green	Attention.	Most likely a power supply or fan assembly has faulted. Verify the status and check all messages.
	Steady amber (for more than 5 seconds)	A system fault has occurred or the device is in an initialization state.	Check the management interface and the error log for details on the cause of the status. Contact your service provider.
Ethernet Link (Management port) (one LED [green])	Off (no light)	There is no link.	No action required.
	Steady green	Link is present.	No action required.
Ethernet Activity (Management port) (one LED [green])	Off (no light)	There is no activity.	No action required.
	Blinking green	There is activity (traffic).	No action required.
VDX 6740 Ethernet ports			
All user ports.	Off (no light)	Port is in no shut state and no cable or transceiver present, no link, 40 GbE port in SFP breakout mode (also referred to as 4x10 GbE breakout mode) has no cable, or license is not available for the port.	Insert SFP+ or QSFP with cable connected to another port in no shut state or connect cable to 40 GbE port.
	Steady amber	Protocol down or no sync or 40 GbE port in 40G mode has no cable.	Check the local port SFP+ or QSFP or peer port SFP+ or QSFP and cable.
	Slow blinking amber	Port is shut or chassis disabled or POST failed.	Enable the port.
	Fast blinking amber	Port is faulted, goes into shut state.	Check messages for fault reason and take necessary action.
	Steady green	Link is present, no activity.	No action required.
	Slow blinking green	Port is good except ISL is segmented.	No action required.
	Fast blinking green	Beaconing enabled.	No action required.
	Flickering green	Online, frames flowing through the port.	No action required.
VDX 6740T and VDX 6740 Ethernet ports			

TABLE 3 Port side LED patterns during normal operation (continued)

LED name	LED color	Status of hardware	Recommended action
Ethernet ports in either 10 GbE or 1 GbE mode (one green LED per port)	Off (no light)	Port is shut, no link, or no license is available for this port.	Enable the port.
	Steady amber	Protocol down or no sync.	Check the local port SFP+ or QSFP or peer port SFP+ or QSFP and cable.
	Slow blinking amber	Port is shut or chassis disabled or POST failed.	Enable the port.
	Fast blinking amber	Port has faulted and goes into shut state.	Check messages for fault reason and take necessary action.
	Steady green	Link is present, no activity.	No action required.
	Slow blinking green	Port is good except ISL is segmented.	No action required.
	Fast blinking green	Beaconing enabled.	No action required.
	Flickering green	Online, frames flowing through the port.	No action required.
40 GbE Ethernet ports (QSFP) in 40 GbE mode (one bicolor LED [green and amber] per port)	Off (no light)	Port is no shut and no QSFP is inserted or 40G port on demand (POD) license not installed.	Connect media and cable or install POD license.
	Steady green	Link is present, no activity.	No action required.
	Blinking green	Beaconing enabled, online with frames flowing through the port.	No action required.
	Steady amber	QSFP is inserted but no fiber or link detected.	Insert cable or check cable on peer 40 GbE port.
	Flashing amber	Port is shut or chassis disabled or POST failed	Check messages.
40 GbE Ethernet ports (QSFP) in 4x10 GbE breakout mode (one bicolor LED [green and amber] per 40 GbE port)	Off (no light)	All of the enabled ports (no shut) have no media or cable or one, two, or three ports are shut. The 40G port on demand (POD) license not installed.	Connect media and cable or install POD license.
	Steady green	All no shut ports are online. Any unused ports must be shut.	No action required.
	Blinking green	Beaconing enabled, online with frames flowing through the port.	No action required.
	Steady amber	Some no shut ports are not connected.	Ensure that any unconnected ports are shut.
	Flashing amber	All four breakout ports are shut or chassis is disabled or POST failed.	Check messages.

The following table describes the LEDs on the non-port side of the device..

TABLE 4 Non-port-side LED patterns during normal operation

LED name	LED color	Status of hardware	Recommended action
Power supply and fan assembly status (one LED [green] per power supply and fan assembly)VDX 6740	Off (no light)	Assembly is not receiving power or is turned off.	Verify the assembly is on and seated and the power cord is connected to a functioning power source.
	Steady green	Assembly is operating normally.	No action required.

TABLE 4 Non-port-side LED patterns during normal operation (continued)

LED name	LED color	Status of hardware	Recommended action
	Blinking green	One of the following may have occurred: <ul style="list-style-type: none"> Mismatched airflow on power supply and fan assembly. One or more of the fans in the fan assembly has failed or the power supply has failed. The power cord has been unplugged. 	Take one of the following actions: <ul style="list-style-type: none"> Replace power supply and fan assembly with a power supply and fan assembly that has correct airflow direction. Replace the power supply and fan assembly. Check the power plug.
Power supply status (one LED [green] per power supply) (VDX 6740T)	Off (no light)	Power supply is not receiving power or is off.	Verify the power supply is on and seated and the power cord is connected to a functioning power source.
	Steady green	Power supply is operating normally. Also, airflow mismatch or fault may have been detected.	No action required. Check messages or use the show environment command to check the state of the power supply.
	Blinking green	Power supply is faulty.	Try the following: <ul style="list-style-type: none"> Check the power cable connection. Verify that the power supply is powered on. Replace the power supply.
Fan status (one bicolor LED [green and amber] per fan assembly) (VDX 6740T)	Off (no light)	Fan assembly is not receiving power.	Try the following: <ul style="list-style-type: none"> Verify the fan assembly is seated correctly. Verify the device is powered on.
	Steady green	Fan assembly is operating normally.	No action required.
	Steady amber (for more than 5 seconds)	Fan fault for one of the following reasons: <ul style="list-style-type: none"> Mismatched airflow on fan assemblies. One or more of the fans in the fan assembly has failed. The fan assembly was disabled by the user. <p>NOTE When the device is first powered on, the fan status LED will show amber until POST has completed.</p>	Try the following: <ul style="list-style-type: none"> Verify that the airflow symbol and part number on the replacement fan matches the fans in the chassis. Replace if necessary. Replace the fan assembly. Verify the fan assembly is enabled (use the show environment fan command). Re-enable if necessary.

POST and boot specifications

When the device is turned on or rebooted, the device performs a power-on, self-test (POST). Total boot time with POST can be several minutes. POST can be omitted after subsequent reboots by using the **fastboot** command or entering the **no diag post** command to persistently disable POST.

For more information about these commands, refer to the *Extreme Network OS Command Reference*.

POST

The success or failure results of the diagnostic tests that run during POST can be monitored through LED activity, the error log, or the command line interface.

POST includes the following tasks:

- Conducts preliminary POST diagnostics.
- Initializes the operating system.
- Initializes hardware.
- Runs diagnostic tests on several functions, including circuitry, port functionality, memory, statistics counters, and serialization.

Boot

In addition to POST, boot includes the following tasks after POST is complete:

- Performs port configuration.
- Initializes links.
- Analyzes fabric. If any ports are connected to other devices, the device participates in a fabric configuration.
- Obtains a domain ID and assigns port addresses.
- Constructs unicast routing tables.
- Enables normal port operation.

Interpreting POST results

POST is a system check that is performed each time the device is powered on, rebooted, or reset. During POST, the LEDs flash either amber or green. Any errors that occur during POST are listed in the error log.

Complete the following steps to determine whether POST completed successfully and whether any errors were detected.

1. Verify that the device LEDs indicate that all components are healthy.
Refer to "LED patterns" for descriptions and interpretations of LED patterns.
2. Verify that the device prompt displays on the terminal of a computer workstation connected to the device.

If there is no device prompt when POST completes, press **Enter**. If the device prompt still does not display, try opening a Telnet session or accessing the device through another management tool. If this is not successful, the device did not successfully complete POST. Contact your service provider for repair.

3. Review the device system log for errors. Any errors detected during POST are written to the system log, accessible through the **show logging raslog** command.

For information about all referenced commands, and on accessing the error log, refer to the *Extreme Network OS Command Reference*. For information about error messages, refer to the *Extreme Network OS Message Reference*.

Powering off the device

To power off the VDX 6740, set the on/off switch to the "off" position on both power supplies.

To power off the per power supply VDX 6740T, you must unplug both power supplies.

Thermal operations

Thermal sensors located in the device sense temperature levels during operation to drive fan speed. In cases of extreme temperature, a RASlog message is generated warning of automatic system shutdown in two minutes, at which time the system shuts down. When the system shuts down, fans continue to run at high speed.

Device maintenance

These devices are designed for high availability and low failure; not require any regular physical maintenance. The SFP+ optical transceivers and diagnostic tests are described in the following sections.

Installing an Ethernet SFP+ transceiver

Only the VDX 6740 supports 10 GbE SFP+ transceivers. Complete the following steps to install an SFP+ transceiver.

1. Remove any protector plugs from the transceivers and the ports.
2. Making sure that the bail (wire handle) is in the unlocked position, place the SFP+ transceiver in the correctly oriented position on the port, as shown in the following figure.
3. Slide the SFP+ transceiver into the port until you feel it click into place; then close the bail.

4. Insert your cable of choice. The cable is keyed to be installed correctly.

NOTE

Each SFP+ transceiver has a 10-pad gold-plated edge connector on the bottom. The correct position to insert an SFP+ transceiver in the upper row of ports is with the gold-plated edge down. The correct position to insert an SFP+ transceiver in the lower row of ports is with the gold-plated edge up.

FIGURE 67 Installing an SFP+ transceiver in the upper row of port slots

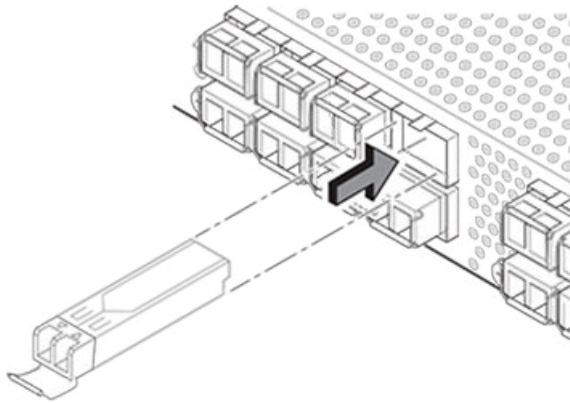

Installing a FC SFP+

For FC port operation using the FlexPort feature, the VDX 6740 supports Extreme-branded 8 Gbps and 16 Gbps SFP+ optical transceivers. These transceivers support any combination of Short Wavelength (SWL), Long Wavelength (LWL), and Extended Long Wavelength (ELWL) optical media. The VDX 6740T supports 4x16G QSFP+ SW transceivers on 40 GbE ports for Fibre Channel operation.

If you use an unqualified transceiver, the **switchShow** command output shows the port in a Mod_Inv state. Fabric OS also logs the issue in the system error log.

Complete the following steps to install an SFP+ transceiver. Refer to the following figures.

1. Making sure that the bail (wire handle) is in the unlocked position, position the optical transceiver so that the key is oriented correctly to the port. Insert the transceiver into the port until it is firmly seated and the latching mechanism clicks, and then close the bail.

Transceivers are keyed so that they can only be inserted with the correct orientation. If a transceiver does not slide in easily, ensure that it is correctly oriented.

2. Position a cable so that the key (the ridge on one side of the cable connector) is aligned with the slot in the transceiver. Insert the cable into the transceiver until the latching mechanism clicks.

Cables are keyed so that they can be inserted only one way. If a cable does not slide in easily, ensure that it is correctly oriented.

NOTE

Each SFP+ has a 10-pad gold-plated PCB-edge connector on the bottom. The correct position to insert an SFP+ into the upper row of ports is with the gold edge down. The correct position to insert an SFP+ into the lower row of ports is with the gold edge up.

FIGURE 68 Installing a 16 Gbps SFP+ in the upper row of port slot

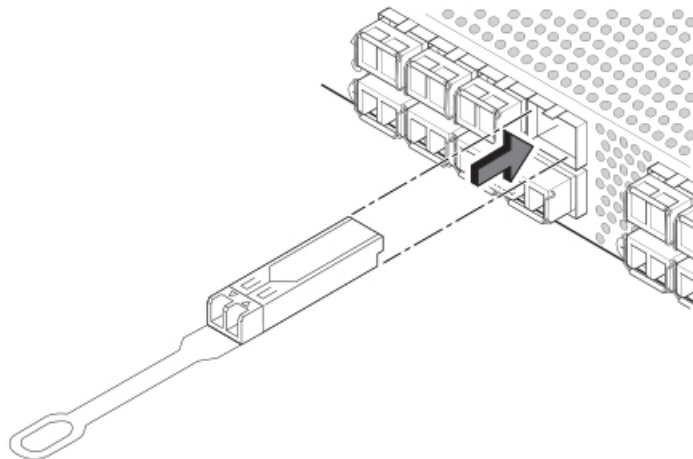
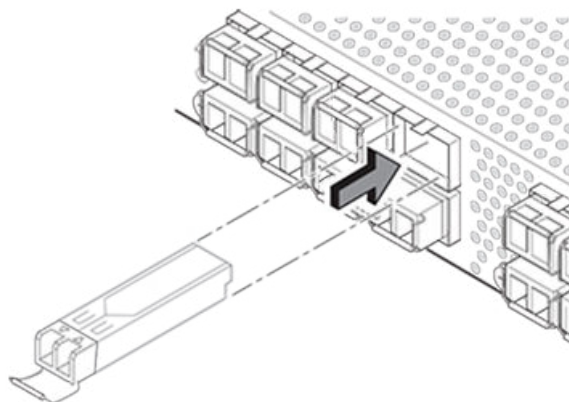

FIGURE 69 Installing an 8 Gbps SFP+ in the upper row of port slot



Diagnostic tests

In addition to POST, the Network OS includes diagnostic tests to help you troubleshoot the hardware and firmware. This includes tests of internal connections and circuitry, fixed media, and the transceivers and cables in use.

The tests are implemented by command, either through a Telnet session or through a console set up to the serial connection to the device. Some tests require the ports to be connected by external cables to allow diagnostics to verify the serializer/deserializer interface,

transceiver, and cable. Some tests require loopback plugs. Refer to the *Extreme Network OS Management Configuration Guide* and the *Extreme Network OS Command Reference* for more details about diagnostic tests and commands.

Diagnostic tests run at link speeds of 1 or 10 Gbps depending on the speed of the link being tested and the type of port.

NOTE

Diagnostic tests may temporarily lock the transmit and receive speed of the links during diagnostic testing.

To monitor the transceivers, the **show media** command output provides transceiver information for all interfaces on the device. Any unqualified transceiver is disabled and a log message is generated.

Upgrading firmware

Use the ExtremeSwitching Network OS **firmware download** command to download firmware to the VDX 6740 device. You can download the firmware from a remote server using the File Transfer Protocol (FTP), SSH File Transfer Protocol (SFTP), Secure Copy Protocol (SCP), or you can download firmware from an attached Extreme Networks-branded USB device. For procedures to update firmware, refer to the "Basic firmware upgrade" section of the *Extreme Network OS Software Upgrade Guide*. For details on command usage, refer to the *Extreme Network OS Command Reference*.

At Network OS 7.1 and later, you can update firmware on the VDX 6740T AQ1402 PHY chips. Each of these chips have a on-board IRAM that can be gang loaded with a firmware image from an external flash chip connected to one of the AQ1402 chips (which is the master chip).

Use the **firmware peripheral-update microcode** command to upgrade PHY firmware from a Extreme Networks-branded USB or from firmware copied to flash memory. For update procedures, refer to the "Updating the peripheral firmware" section of the *Extreme Network OS Software Upgrade Guide*. For details on command usage, refer to the *Extreme Network OS Command Reference*.

Device management

You can use the management functions built into the device to monitor the fabric topology, port status, physical status, and other information to help you analyze device performance and to accelerate system debugging.

For information about upgrading the version of Network OS installed on your device, refer to the *Extreme Network OS Software Upgrade Guide*.

You can manage this device using any of the management options listed in the following table.

TABLE 5 Management options

Management tool	Out-of-band support
Command line interface (CLI) For more information, refer to the <i>Extreme Network OS Management Configuration Guide</i> and the <i>Extreme Network OS Command Reference</i> .	Ethernet or serial (console port) connection
Standard SNMP applications For information, refer to the <i>Extreme Network OS Management Configuration Guide</i> .	Ethernet or serial (console port) connection
Extreme Network Advisor For information, refer to the <i>Extreme Network Advisor SAN+IP User Manual</i> .	Ethernet (preferred) or serial (console port) connection

Removal and Replacement Procedures

- Before beginning replacement109
- FRU replacement in a VDX 6740.....110
- FRU replacement in the VDX 6740T.....112

Before beginning replacement

The field-replaceable units (FRUs) can be removed from the device and replaced without special tools. The device can continue operating during the FRU replacements if the conditions specified in the procedures are followed.

NOTE

Read the "Caution and Danger Notices" in this guide before servicing.



CAUTION

This document describes how to change field-replaceable units (FRUs) for units with either a port-side air exhaust or a port-side air intake. You must replace a failed FRU with a FRU of the same type. This applies to both power supplies and fan assemblies. A new FRU must have the same part number (P/N) as the FRU being replaced. The manufacturing P/N is located on the top of the FRU. The P/N ends in either -F (front-to-rear airflow) or -R (rear-to-front airflow). You must use a replacement FRU that has the same airflow designator with the part number.



DANGER

The procedures in this manual are for qualified service personnel.

If a mismatched power source or fan assembly is installed by mistake, a warning is sent to the console. Warning messages will be similar to the following:

- For a fan mismatch: WARNING, [product name] , MISMATCH in FAN Air Flow direction. Replace FRU with fan air flows in same direction.
- For a power supply or combined power supply and fan mismatch: WARNING, [product name], MISMATCH in PSU-FAN FRUS Air Flow direction. Replace PSU with fan air flow in same direction.

You can use external labels as a guide. The power supply and fan assemblies are labeled with an airflow symbol on the faceplate to indicate whether the FRU takes in or exhausts air. The symbol also appears on the top of the FRU. All FRUs in a chassis must have the same label affixed so that airflow direction is consistent. The following illustration shows examples of the airflow labels.



CAUTION

Ensure that the airflow direction of the power supply unit matches that of the installed fan tray. The power supplies and fan trays are clearly labeled with either a green arrow with an "E", or an orange arrow with an "I."

FIGURE 70 Examples of airflow symbols



The green **E** symbol indicates an exhaust FRU. This unit pulls air in from the port side of the device and exhausts it out the non-port side. This is called front-to-back airflow or exhaust airflow. This symbol should appear on FRUs with part numbers ending with **-F**.

The orange **I** symbol indicates an intake FRU. This unit pulls air in from the non-port side of the device and exhausts it out the port side. This is called back-to-front airflow or intake airflow. This symbol should appear on FRUs with part numbers ending with **-R**.

FRU replacement in a VDX 6740

Field replaceable units (FRUs) in the ExtremeSwitching VDX 6740, consist of combined power supply and fan assemblies. This section includes procedures to remove and replace these assemblies, time and items required for replacement, and determining if replacement is needed, and procedures to remove and replace the combined power supply and fan assemblies.

ExtremeSwitching Network OS identifies the power supply and fan assemblies from left to right as power supply and fan assembly #2 and power supply and fan assembly #1 when viewed from the non-port side of the device. For locations of these assemblies, captive screws, LEDs, labels, and other components, refer to the non-port side view of the VDX 6740 in [Hardware components](#) on page 18.

NOTE

Maintain all power supply and fan assemblies in operational condition to provide redundancy.



CAUTION

Because the cooling system relies on pressurized air, do not leave any of the power supply and fan assembly slots empty longer than two minutes while the switch is operating. If a power supply or fan assembly fails, leave it in the switch until it can be replaced.

**CAUTION**

Disassembling any part of the power supply and fan assembly voids the warranty and regulatory certifications. There are no user-serviceable parts inside the power supply and fan assembly.

Refer to details on the meaning of LED patterns for the VDX 6740 power supply and fan assemblies in [LED patterns](#) on page 101 to verify operation and determine if replacement is necessary.

Determining the need to replace an assembly

Use one of the following methods to determine the status of the assemblies:

- Check the power supply and fan assembly status LED.
- Enter one of the following commands in the command line interface to display power supply status:
 - **show chassis**
 - **show environment power**
 - **show environment fan**
- Check the power supply status in the Web Tools application.

Time and items required

Replacing a combined power supply and fan assembly should take less than two minutes.

You need the following items to replace a power supply and fan assembly in a VDX 6740-:

- A new power supply and fan assembly (must have the same part number and the same airflow label as the power supply and fan assembly being replaced)
- A #1 Phillips screwdriver

Replacing the power supply and fan assembly

Remove a failed combined power supply and fan assembly, install a new combined FRU, and verify the replacement was successful.

**CAUTION**

The power supply switch must be in the off position when you insert the power supply into the chassis. Damage to the switch can result if a live power supply is installed.

1. Flip the power switch to the off position (O).
2. Unplug the power cord from the combined power supply and fan assembly you are replacing.
3. Unscrew the captive screw on the power supply and fan assembly you are replacing using the Phillips screwdriver.
4. Remove the power supply and fan assembly from the chassis by pulling the handle out and away from the chassis.
5. Ensure that the new power supply and fan assembly has the same part number as the FRU being replaced.

6. Install the new FRU in the chassis:
 - a) Orient the new power supply and fan assembly with the captive screw on the right as shown in the following illustration.
 - b) Gently push the power supply and fan assembly into the chassis until it is firmly seated.

**CAUTION**

Do not force the installation. If the power supply and fan assembly does not slide in easily, ensure that it is correctly oriented before continuing.

- c) Using the Phillips screwdriver, secure the power supply and fan assembly to the chassis by tightening the captive screw.

FIGURE 71 Orientation of the AC or DC power supply and fan assembly in the VDX 6740

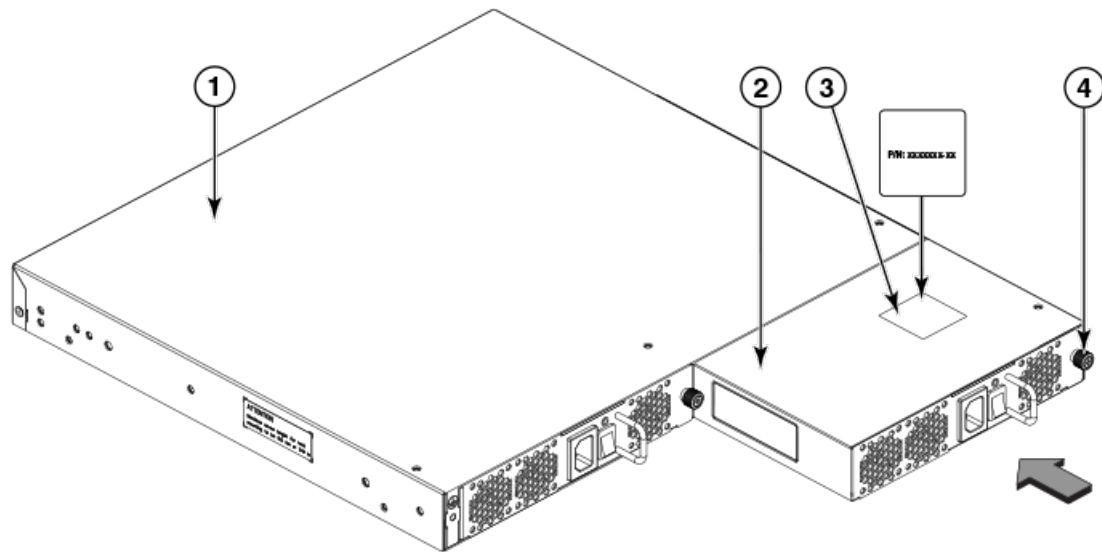

- | | |
|---|---------------------------|
| 1. VDX 6740 chassis | 3. Label with part number |
| 2. AC or DC power supply and fan assembly | 4. Captive screw |

7. Verify that the power supply and fan assembly status LED is steady green to indicate normal operation.

Refer to [LED activity interpretation](#) on page 99 for more LED information.

Display the power supply and fan assembly status using the following Network OS commands:

- - **show system**
- **show environment fan**
- **show environment power**

FRU replacement in the VDX 6740T

Field replaceable units (FRUs) in the VDX 6740T include separate power supply and fan assemblies. This section provides details on removing and replacing these FRUs, time and items required for replacement, and determining if replacement is needed.

Network OS identifies the power supply assemblies from left to right as power supply #2 and power supply and power supply #1 when viewed from the non-port side of the device. For locations of these assemblies, captive screws, LEDs, labels, and other components, refer to the non-port side view of the VDX 6740T in [Hardware components](#) on page 18.

Network OS identifies fan assemblies from left to right as fan #1, fan #2, fan #3, fan #4, and fan #5 when viewed from the non-port side of the device. For locations of these assemblies, captive screws, LEDs, labels, and other components, refer to the non-port side view of the VDX 6740T in [Hardware components](#) on page 18.

NOTE

Maintain all power supply and fan assemblies in operational condition to provide redundancy.



CAUTION

Because the cooling system relies on pressurized air, do not leave any of the power supply and fan assembly slots empty longer than two minutes while the switch is operating. If a power supply or fan assembly fails, leave it in the switch until it can be replaced.



CAUTION

Disassembling any part of the power supply and fan assembly voids the warranty and regulatory certifications. There are no user-serviceable parts inside the power supply and fan assembly.



DANGER

The procedures in this manual are for qualified service personnel.

Refer to details on the meaning of LED patterns for the VDX 6740T power supplies and fans in [LED patterns](#) on page 101 to verify operation and determine if replacement is necessary.

Determining the need to replace a power supply

Use one of the following methods to determine the status of the power supplies:

- Check the power supply status LEDs. Refer to "Interpreting LED activity" for details on LED normal operation and error conditions.
- Enter one of the following commands in the command line interface to display power supply status:
 - **show chassis**
 - **show environment power**
- Check the power supply status in the Web Tools application.

Time and items required to replace a power supply

Replacing a power supply should take less than two minutes to complete.

You need the following items to replace a power supply:

- A new power supply (must have the same part number and the same airflow label as the power supply being replaced)
- A #2 Phillips-head screwdriver

Replacing a 500W AC power supply

Complete the following steps to replace a 500W AC power supply.

NOTE

Before beginning the replacement, refer to the precautions in "Power precautions."

1. If leaving the device in service while replacing a power supply, verify that the other power supply (the one not being replaced) has been powered on for at least four seconds and has a steady green status LED.

2. Ensure that the replacement power supply has the same part number and airflow label as the power supply being replaced.
3. Unplug the power cord from the power supply that is being replaced.
4. Using the Phillips screwdriver, unscrew the two captive screws on the power supply.
5. Remove the power supply from the chassis by grasping the edges of the power supply and pulling it out from the chassis.

FIGURE 72 Inserting the power supply

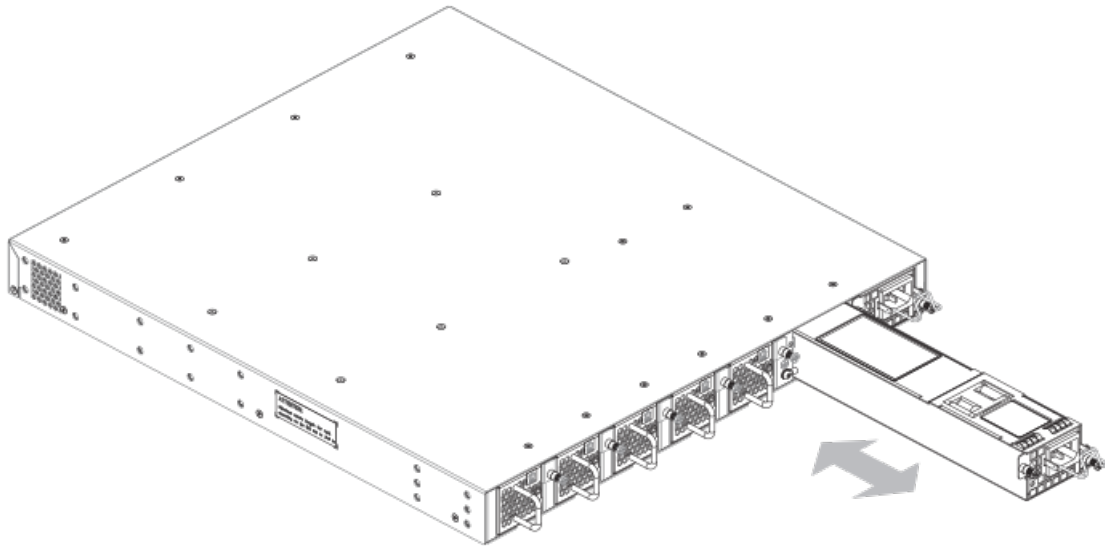

6. Place the power supply in an anti-static bag for storage.
7. If the empty power supply bay where you are installing the replacement power supply has a cover plate, remove the two screws near the edges of the cover plate to unlock the plate, and then remove the plate.
8. Remove the replacement power supply from its packaging.
9. To install the power supply into the chassis, orient the power supply with the power plug receptacle on the right, as shown in the previous illustration.
10. With one hand, hold the bar on the front panel of the power supply. With the other hand, support the underside of the power supply, and insert the power supply into the empty power supply slot. Gently push the power supply into the chassis until it is firmly seated.



CAUTION

Carefully follow the mechanical guides on each side of the power supply slot and make sure the power supply is properly inserted in the guides. Never insert the power supply upside down.

NOTE

Do not force the installation. If the power supply does not slide in easily, ensure that the power supply is correctly oriented before continuing.

11. Secure the power supply to the chassis by tightening the two captive screws using the Phillips screwdriver.

12. Plug the power cord from the AC power source into the power supply to power on the unit.

The power supply will immediately attempt to power up.



CAUTION

If you observe that the switch has powered down approximately two minutes after a power supply replacement, it is likely because the new power supply has a mismatched airflow. Check your console for error messages.

13. Verify that the LED on the new power supply displays steady green while the device is operating.

If the LED is not steady green, ensure that the power supply is securely installed and seated properly.

You can enter one of the following commands at the command line prompt to display the power supply status:

- **show chassis**
- **show environment power**

The power supply status can also be viewed using the Web Tools application.

Determining the need to replace a fan assembly

Use one of the following methods to determine the status of the fan assemblies:

- Check the fan status LED on the face of the fan. Refer to "Interpreting LED activity" for details on LED normal operation and error conditions.
- Enter one of the following commands in the command line interface to display the fan status:
 - **show chassis**
 - **show environment fan**

Time and items required to replace a fan assembly

Replacing a fan assembly should take less than two minutes.

You need the following items to replace a fan assembly:

- A new fan assembly (must have the same part number and the same airflow label as the fan being replaced)
- A #1 Phillips screwdriver

Replacing a fan assembly

Complete the following steps to replace a fan assembly.

1. Using the Phillips screwdriver, unscrew the captive screw on the fan assembly.
2. Ensure that the replacement fan assembly has the same part number and airflow label as the fan assembly being replaced.
3. Remove the fan assembly from the chassis by pulling the handle on the fan assembly out and away from the chassis.

4. Install the new fan assembly in the chassis:
 - a) Orient the new fan assembly with the captive screw on the right, as shown in the following illustration.
 - b) Gently push the fan assembly into the chassis until it is firmly seated.

**CAUTION**

Do not force the installation. If the power supply and fan assembly does not slide in easily, ensure that it is correctly oriented before continuing.

If the device is powered up, the fan will immediately power up.

- c) Using the Phillips screwdriver, secure the fan assembly to the chassis by tightening the captive screw.

FIGURE 73 Inserting the fan assembly

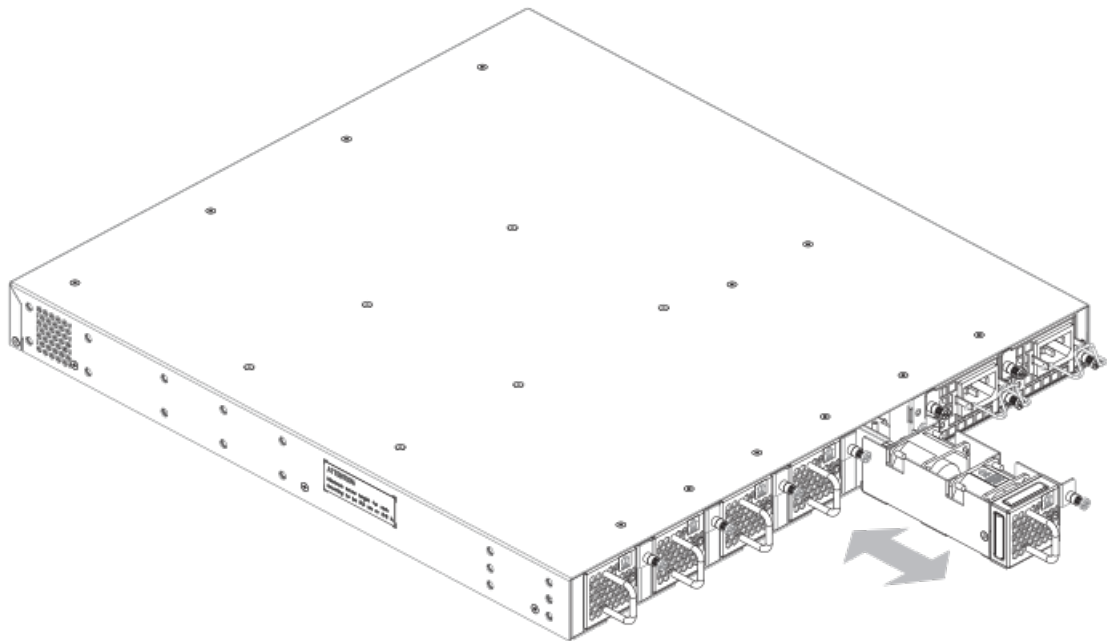

5. Verify that the fan status LED is steady green to indicate normal operation.

If the LED is not steady green, ensure that the fan is securely installed and seated properly.

You can enter one of the following commands at the command line prompt to display fan status:

- **show chassis**
- **show environment fan**

The fan status can also be viewed using the Web Tools application.

Technical Specifications

- ExtremeSwitching VDX 6740 Switch Technical Specifications.....117

ExtremeSwitching VDX 6740 Switch Technical Specifications

This document highlights the features and specifications for the ExtremeSwitching VDX 6740 family of switches.

System specifications

System component	Description
Enclosure	1U, 19-inch EIA-compliant
Power inlet	AC: C14; power from nonport side DC: 3 Position Terminal Block, Minimum input wire 16 AWG/300V/90C
Power supplies	Two internal, redundant, field-replaceable, load-sharing AC or DC power supplies
Fans	Extreme VDX 6740 - 3 cooling fans integrated into power supplies Extreme VDX 6740T - 5 cooling fans
Cooling	Rear-to-front or front-to-rear airflow
System architecture	Non-blocking shared memory switch
System processors	1.5 GHz PowerPC

Ethernet

System component	Description
SFP GbE ports	VDX 6740 - 64 1x10 GbE SFP+ ports VDX 6740T <ul style="list-style-type: none">• 16 1X10 GbE SFP+ ports• Four 40 GbE QSFP+ VDX 6740T - Four 40 GbE QSFP+ ports
Ethernet management port	RJ-45 Ethernet out-of-band management port operating at 1 Gbps

LEDs

System component	Description
Switch status and management	VDX 6740 and VDX 6740T <ul style="list-style-type: none">• One bicolor system status LED (green and amber) on the port side• one power status LED (green) on the port side• Two Ethernet management port LEDs (green) for the Ethernet management port• One triangle-shaped bicolor port status LED (green and amber) for each 10 GbE port on the switch

System component	Description
	<ul style="list-style-type: none"> One triangle-shaped bicolor port status LED (green and amber) for each 40 GbE port on the switch One power supply and fan assembly LED (green) above the AC power switch on each combined power supply and fan assembly on the non-port side of the switch VDX 6740T <ul style="list-style-type: none"> One power supply LED (green) to the left of the AC power plug on each power supply on the non-port side of the switch One bicolor fan status LED (green and amber) on each fan assembly on the non-port side of the switch

Other

System component	Description
Serial cable	Rollover cable
RJ-45 connector	VDX 6740 - Used for the serial port.
Mini-USB connector	VDX 6740T - Used for the serial port.

Weight and physical dimensions

Fully loaded with all power supplies and fan assemblies, and no transceivers installed.

Model	Height	Width	Depth	Weight
Extreme VDX 6740	4.32 cm	43.99 cm	40.99 cm	8.66 kg
	1.75 in	17.32 in	16.14 in	19.10 lb
Extreme VDX 6740T	4.27 cm	43.74 cm	53.65 cm	10.82 kg
	1.68 in	17.22 in	21.12 in	23.85 lb

Environmental requirements

Condition	Operational	Non-operational
Ambient temperature	0°C to 40°C (32°F to 104°F)	-25°C to 70°C (-13°F to 158°F)
Relative humidity (non-condensing)	10% to 85% at 40°C (104°F)	10% to 90% at 70°C (158°F)
Altitude (above sea level)	0 to 3048 m (10,000 feet)	0 to 12000 m (40,000 feet)
Shock	20 G, 11 ms, half-sine wave	44 G, 15 ms, square wave,
Vibration	0.5 G peak, 0.7 gms random, 5 to 500 Hz	2.0 G sine, 1.4 gms random, 5 to 500 Hz
Airflow	VDX 6740 - Maximum: 43.7 cmh (25.7 cfm) Nominal: 19.5 cmh (11.5 cfm) VDX 6740T - Maximum: 83.8 cmh (49.3 cfm) Nominal: 44.7 cmh (26.3 cfm)	N/A
Heat dissipation	Refer to Power Consumption for Heat Dissipation	N/A
Operating noise	VDX 6740 and VDX 6740T - 46.7 dB	N/A

Power supply specifications (per PSU)

Power supply model	Maximum output power rating (DC)	Input voltage	Input line frequency	Maximum input current	Input line protection	Maximum inrush current
AC to DC - VDX 6740 XBR-250WPSAC-F Or XBR-250WPSAC-R	250 W	100 - 240 VAC (nominal) 90 - 264 VAC (range)	50/60 Hz (nominal) 47 - 63 Hz (range)	3.5 A	Line Fused	50 A peak @ 240 VAC at cold start for < 10 ms, 15 A peak for cycles 10 ms - 150 ms, < 3.5 A peak for > 150 ms
AC to DC - VDX 6740T XBR-500WPSAC-F Or XBR-500WPSAC-R	504 W	100 - 240 VAC (nominal) 90 - 264 VAC (range)	50/60 Hz (nominal) 47 - 63 Hz (range)	6 A @ 100 VAC 7 A @ 85 VAC	Line Fused	30 A peak at cold start & 50 A peak at warm start for < 10 ms, 10 A peak for cycles 10 ms - 150 ms, < 7 A peak for >150 ms
DC to DC - VDX 6740 XBR-250WPSDC-F Or XBR-250WPSDC-R	250 W	48Vdc (nominal) 40-60Vdc (range) 40-60Vdc with + or - zero percent tolerance	N/A	7.1 A	-Ve and return fused	50 A peak for any initial current surge, or spike of 10ms or less
DC to DC - VDX 6740T RP59DC+E Or RP59DC+I	504 W	48Vdc (nominal) 40Vdc-60Vdc (range)	N/A	15 A	-Ve Fused	25 A peak @ 25°C

Power consumption VDX 6740 and VDX 6740T (idle configuration)

No optics or connections to ports and system booted up. Fans at nominal speed.

Model	@ 100 VAC input	@ 200 VAC input	@-48 VDC Input	Maximum number of power supplies	Notes
VDX 6740	0.842 A 91 W 310.59 BTU/hr	0.473 A 96 W 317.42 BTU/hr	1.5 A 77 W 262.94 BTU/hr	1	Input current is for 1 PSU, Watts & BTUs/hr are for two PSUs.
VDX 6740T	2.049 A 225 W 767.94 BTU/hr	1.05 A 219 W 747.46 BTU/hr	4.12 A 208 W 711.46 BTU/hr	1	Input current is for 1 PSU, Watts & BTUs/hr are for two PSUs.

Power consumption VDX 6740 (typical configuration)

All ports fully configured with 48x10 GbE and 4x40 GbE ports at 25 percent traffic rate. Fans are set at nominal speed.

Model name	@100 VAC input	@200 VAC input	@-48 VDC input	Minimum number of power supplies	Notes
VDX 6740	1.34 A 140 W 477.83 BTU/hr	0.473 A 145 W 494.9 BTU/hr	2.93 A 140.6 W 480.02 BTU/hr	1	Input current is for 1 PSU, Watts and BTU/Hr are with two PSUs.
VDX 6740T	4.393 A 446 W 1522.23 BTU/hr	2.179 A 440 W 1501.76 BTU/hr	8.67 A 416 W 1420.39 BTU/hr	1	Input current, Watts, BTU/Hr are with only one power supply.

Power consumption VDX 6740T (typical configuration)

Data in the following table is for a VDX 6740T using Network OS v7.1.0 and PHY firmware v1.38.c1. All ports are fully configured with 48 10 GbE ports at 100 percent traffic rate and 4x40 GbE ports at 25 percent traffic rate. Fans are set at nominal speed.

NOTE

Extreme Network OS 7.1.0 increases nominal fan speed for port-side exhaust airflow. Increased fan speed is also available in Network OS 7.0.1 in 6.0.2a2, 5.0.2b2, 5.0.1d3, and 4.1.3c1 builds. These builds use PHY firmware 1.38.c1 (refer to TSB 2016-236-A).

Model name	@100 VAC input	@200 VAC input	@-48 VDC input	Minimum number of power supplies	Notes
VDX 6740T	4.728 A 470 W 1604.15 BTU/hr	2.34 A 471 W 1607.56 BTU/hr	9.6 A 461 W 1572.75 BTU/hr	1	Input current is with one power supply; Watts and BTU/Hr are with two power supplies.

Data in the following table is for a VDX 6740T using Network OS v7.1.0 and PHY firmware v1.39.c1. LAN cables from the 48x10 GbE ports are less than 30 m (98.42 ft). All ports are fully configured with 48x10 GbE ports at 100 percent traffic rate and 4x40 GbE ports at 25 percent traffic rate. Fans are set at nominal speed.

Model name	@100 VAC input	@200 VAC input	@-48 VDC input	Minimum number of power supplies	Notes
VDX 6740T	4.105 A 421 W 1436.91 BTU/hr	2.105 A 410 W 1399.36 BTU/hr	8.2 A 394 W 1343.39 BTU/hr	1	Input current is with one power supply; Watts and BTU/Hr are with two power supplies.

Data in the following table is for a VDX 6740T using Network OS v7.1.0 and PHY firmware v1.39.c1. LAN cables from the 48 10 GbE ports are greater than 30 m (98.42 ft). All ports are fully configured with 48x10 GbE ports at 100 percent traffic rate and 4x40 GbE ports at 25 percent traffic rate. Fans are set at nominal speed.

Model name	@100 VAC input	@200 VAC input	@-48 VDC input	Minimum number of power supplies	Notes
VDX 6740T	4.728 A 470 W 1604.15 BTU/hr	2.34 A 471 W 1607.56 BTU/hr	9.6 A 461 W 1572.75 BTU/hr	1	Input current is with one power supply; Watts and BTU/Hr are with two power supplies.

Power consumption VDX 6740 and 6740T (maximum configuration)

All ports fully configured with 48x10 GbE & 4x40 GbE ports at 100 percent traffic rate. Switch fans set at high speed.

Model name	@100 VAC input	@200 VAC input	@-48 VDC input	Minimum number of power supplies	Notes
VDX 6740	1.711 A 182 W 621.18 BTU/hr	0.857 A 175 W 597.29 BTU/hr	3.46 A 166 W 566.67 BTU/hr	1	Input current is for 1 PSU, Watts and BTU/Hr are with two PSUs.
VDX 6740T	4.826 A 490 W 1672.41 BTU/hr	2.354 A 475 W 1621.21 BTU/hr	10.06 A 483 W 1648.11 BTU/hr	1	Input current, Watts, BTU/Hr are with only one power supply.

Data port specifications (Ethernet)

Model	Port type	Number of ports	Description
VDX 6740	40 GbE	4	QSFP+ ports can be split into 16 10 GbE SFP+ ports.
	10 GbE	48 + 16	Up to 64 1/10 GbE SFP+ ports depending on configuration.
	1 GbE	48 + 16	Up to 64 1/10 GbE SFP+ ports depending on configuration.
VDX 6740T	40 GbE	4	QSFP+ ports can be split into 16 10 GbE SFP+ ports.
	10 GbE	48 + 16	Up to 16 1/10 GbE SFP+ ports depending on configuration. 48 1/10 GBASE-T ports.
	1 GbE	48 + 16	Up to 16 1/10 GbE SFP+ ports depending on configuration. 48 1/10 GBASE-T ports.

Serial port specifications (pinout mini-USB)

Pin	Signal	Description
1	+5V	Not used
2	UART0_TX	Debug port
3	UART0_RX	Console port
4	IN	Not used
5	GND	Ground

Serial port specifications (pinout RJ-45)

Pin	Signal	Description
1	Not supported	N/A
2	Not supported	N/A
3	UART1_RXD	Receive data
4	GND	Logic ground
5	GND	Logic ground
6	UART1_TXD	Transmit data
7	Not supported	N/A
8	Not supported	N/A

Serial port specifications (protocol)

Parameter	Value
Baud	9600
Data bits	8
Parity	None
Stop bits	1
Flow control	None

Memory specifications

Memory	Type	Size
Main Memory	DDR2 SDRAM	8 GB
Boot Flash		4 MB
Compact Flash		8 GB

Regulatory compliance (EMC)

- FCC Part 15, Subpart B (Class A)
- EN 55022 (CE mark) (Class A)
- EN 55024 (CE mark) (Immunity) for Information Technology Equipment
- ICES-003 (Canada) (Class A)
- AS/NZ 55022 (Australia) (Class A)
- VCCI (Japan) (Class A)
- EN 61000-3-2
- EN 61000-3-3
- EN 61000-6-1

Regulatory compliance (safety)

- CAN/CSA-C22.2 No. 60950/UL 60950
- EN 60825 Safety of Laser Products
- EN 60950/IEC 60950 Safety of Information Technology Equipment

Regulatory compliance (environmental)

- 2011/65/EU - Restriction of the use of certain hazardous substance in electrical and electronic equipment (EU RoHS).
- 2012/19/EU - Waste electrical and electronic equipment (EU WEEE).
- 94/62/EC - packaging and packaging waste (EU).
- 2006/66/EC - batteries and accumulators and waste batteries and accumulators (EU battery directive).
- 1907/2006 of the European Parliament and of the Council of 18 December 2006 concerning the Registration, Evaluation, Authorisation and Restriction of Chemicals (EU REACH).
- Section 1502 of the Dodd-Frank Wall Street Reform and Consumer Protection Act of 2010 - U.S. Conflict Minerals.
- 30/2011/TT-BCT - Vietnam circular.
- SJ/T 11363-2006 Requirements for Concentration Limits for Certain Hazardous Substances in EIPs (China).
- SJ/T 11364-2006 Marking for the Control of Pollution Caused by EIPs (China).

Regulatory Statements

• BSMI statement (Taiwan).....	125
• Canadian requirements.....	125
• CE statement.....	125
• China ROHS.....	126
• FCC warning (US only).....	126
• Germany statement.....	126
• KCC statement (Republic of Korea).....	126
• VCCI statement.....	126
• Japan power cord	127

BSMI statement (Taiwan)

警告使用者：
這是甲類的資訊產品，在居住的環境中使用時，可能會造成射頻干擾，
在這種情況下，使用者會被要求採取某些適當的對策。

Warning:

This is Class A product. In a domestic environment this product may cause radio interference in which case the user may be required to take adequate measures.

Canadian requirements

This Class A digital apparatus meets all requirements of the Canadian Interference-Causing Equipment Regulations, ICES-003 Class A.

Cet appareil numérique de la classe A est conforme à la norme NMB-003 du Canada.

CE statement

ATTENTION

This is a Class A product. In a domestic environment, this product might cause radio interference, and the user might be required to take corrective measures.

The standards compliance label on this device contains the CE mark which indicates that this system conforms to the provisions of the following European Council directives, laws, and standards:

- Electromagnetic Compatibility (EMC) Directive 2014/30/EU
- Low Voltage Directive (LVD) 2014/35/EU
- EN 55032/EN 55024 (European Immunity Requirements)
 - EN61000-3-2/JEIDA (European and Japanese Harmonics Spec)
 - EN61000-3-3

China ROHS

Refer to the latest revision of the China ROHS document (P/N 53-1000428-xx) which ships with the product.

FCC warning (US only)

This equipment has been tested and complies with the limits for a Class A computing device pursuant to Part 15 of the FCC Rules. These limits are designed to provide reasonable protection against harmful interference when the equipment is operated in a commercial environment.

This equipment generates, uses, and can radiate radio frequency energy, and if not installed and used in accordance with the instruction manual, might cause harmful interference to radio communications. Operation of this equipment in a residential area is likely to cause harmful interference, in which case the user will be required to correct the interference at the user's own expense.

Germany statement

Machine noise information regulation - 3. GPSGV, the highest sound pressure level value is 79.0 dB(A) in accordance with EN ISO 7779.

Maschinenlärminformations-Verordnung - 3. GPSGV, der höchste Schalldruckpegel beträgt 79.0 dB(A) gemäss EN ISO 7779.

KCC statement (Republic of Korea)

A급 기기 (업무용 방송통신기기): 이 기기는 업무용(A급)으로 전자파적합등록을 한 기기이오니 판매자 또는 사용자는 이 점을 주의하시기 바라며, 가정외의 지역에서 사용하는 것을 목적으로 합니다.

Class A device (Broadcasting Communication Device for Office Use): This device obtained EMC registration for office use (Class A), and may be used in places other than home. Sellers and/or users need to take note of this.

VCCI statement

この装置は、クラスA情報技術装置です。この装置を家庭環境で使用すると電波妨害を引き起こすことがあります。この場合には使用者が適切な対策を講ずるよう要求されることがあります。 VCCI-A

This is a Class A product based on the standard of the Voluntary Control Council for Interference by Information Technology Equipment (VCCI). If this equipment is used in a domestic environment, radio disturbance might arise. When such trouble occurs, the user might be required to take corrective actions.

Japan power cord



注意 - 添付の電源コードを他の装置や用途に使用しない

添付の電源コードは本装置に接続し、使用することを目的として設計され、その安全性が確認されているものです。決して他の装置や用途に使用しないでください。火災や感電の原因となる恐れがあります。

English translation of above statement

ATTENTION: Never use the power cord packed with your equipment for other products.

Cautions and Danger Notices

- Cautions.....129
- Danger Notices.....133

Cautions

A Caution statement alerts you to situations that can be potentially hazardous to you or cause damage to hardware, firmware, software, or data.

Ein Vorsichtinweis warnt Sie vor potenziellen Personengefahren oder Beschädigung der Hardware, Firmware, Software oder auch vor einem möglichen Datenverlust

Un message de mise en garde vous alerte sur des situations pouvant présenter un risque potentiel de dommages corporels ou de dommages matériels, logiciels ou de perte de données.

Un mensaje de precaución le alerta de situaciones que pueden resultar peligrosas para usted o causar daños en el hardware, el firmware, el software o los datos.

General cautions



CAUTION

Ensure that the airflow direction of the power supply unit matches that of the installed fan tray. The power supplies and fan trays are clearly labeled with either a green arrow with an "E", or an orange arrow with an "I."

VORSICHT	Vergewissern Sie sich, dass die Luftstromrichtung des Netzteils der eingebauten Lüftereinheit entspricht. Die Netzteile und Lüftereinheiten sind eindeutig mit einem grünen Pfeil und dem Buchstaben "E" oder einem orangefarbenen Pfeil mit dem Buchstaben "I" gekennzeichnet.
MISE EN GARDE	Veillez à ce que le sens de circulation de l'air du bloc d'alimentation corresponde à celui du tiroir de ventilation installé. Les blocs d'alimentation et les tiroirs de ventilation sont étiquetés d'une flèche verte avec un "E" ou d'une flèche orange avec un "I".
PRECAUCIÓN	Asegúrese de que la dirección del flujo de aire de la unidad de alimentación se corresponda con la de la bandeja del ventilador instalada. Los dispositivos de alimentación y las bandejas del ventilador están etiquetadas claramente con una flecha verde y una "E" o con una flecha naranja y una "I".



CAUTION

Do not install the device in an environment where the operating ambient temperature might exceed 40°C (104°F).

VORSICHT	Das Gerät darf nicht in einer Umgebung mit einer Umgebungsbetriebstemperatur von über 40°C (104°F) installiert werden.
MISE EN GARDE	N'installez pas le dispositif dans un environnement où la température d'exploitation ambiante risque de dépasser 40°C (104°F).
PRECAUCIÓN	No instale el instrumento en un entorno en el que la temperatura ambiente de operación pueda exceder los 40°C (104°F).



CAUTION

Make sure the airflow around the front, and back of the device is not restricted.

VORSICHT	Stellen Sie sicher, dass an der Vorderseite, den Seiten und an der Rückseite der Luftstrom nicht behindert wird.
MISE EN GARDE	Vérifiez que rien ne restreint la circulation d'air devant, derrière et sur les côtés du dispositif et qu'elle peut se faire librement.

PRECAUCIÓN	Asegúrese de que el flujo de aire en las inmediaciones de las partes anterior, laterales y posterior del instrumento no esté restringido.
------------	---



CAUTION

This document describes how to change field-replaceable units (FRUs) for units with either a port-side air exhaust or a port-side air intake. You must replace a failed FRU with a FRU of the same type. This applies to both power supplies and fan assemblies. A new FRU must have the same part number (P/N) as the FRU being replaced. The manufacturing P/N is located on the top of the FRU. The P/N ends in either -F (front-to-rear airflow) or -R (rear-to-front airflow). You must use a replacement FRU that has the same airflow designator with the part number.

VORSICHT	Das vorliegende Dokument erläutert, wie Austauschkomponenten (FRUs) in Geräten ersetzt werden, bei denen entweder der Luftauslass oder der Lufteinlass auf der Portseite liegt. Ausgefallene FRUs müssen stets durch FRUs desselben Typs ersetzt werden. Dies gilt sowohl für Netzteile als auch für Lüftereinheiten. Neue FRUs müssen stets dieselbe Teilenummer wie die ersetzten FRUs aufweisen. Die Hersteller-Teilenummer befindet sich auf der Oberseite der FRU. Die Teilenummer endet entweder auf „-F“ (Luftstrom von der Vorderseite des Geräts zur Rückseite) oder auf „-R“ (Luftstrom von der Rückseite des Geräts zur Vorderseite). Austauschteile müssen stets Teilenummern mit demselben Kennbuchstaben für den Luftstrom wie das auszutauschende Teil aufweisen.
MISE EN GARDE	Ce document décrit comment changer les pièces détachées des unités qui comportent un refroidissement par une entrée ou une sortie d'air côté port. Vous devez remplacer une pièce détachée défectueuse par une autre du même type. Cela s'applique aux blocs d'alimentation et aux ventilateurs. La pièce détachée doit avoir la même référence que l'ancienne. La référence du fabricant se trouve sur le dessus de la pièce détachée. La référence se termine par -F (flux d'air de l'avant vers l'arrière) ou par -R (flux d'air de l'arrière vers l'avant). Vous devez utiliser une pièce détachée dont l'indicatif de flux d'air est le même.
PRECAUCIÓN	Este documento describe cómo cambiar las unidades reemplazables sobre el terreno (FRU, por sus siglas en inglés) por unidades con salida o entrada de aire por el lado de los puertos. La unidad FRU averiada debe cambiarse por otra del mismo tipo. Esto aplica a las fuentes de alimentación y a los módulos de ventilación. La nueva unidad FRU debe tener el mismo número de parte (P/N) que la unidad FRU que se va a sustituir. El P/N de fabricación se encuentra en la parte superior de la unidad FRU. El P/N termina en -F (flujo de aire de adelante hacia atrás) o -R (de atrás hacia adelante). Debe utilizar una unidad FRU de repuesto que tenga la misma designación de flujo de aire que el número de parte reemplazado.



CAUTION

Ensure that the airflow direction of the power supply unit matches that of the installed fan tray. The power supplies and fan trays are clearly labeled with either a green arrow with an "E", or an orange arrow with an "I."

VORSICHT	Vergewissern Sie sich, dass die Luftstromrichtung des Netzteils der eingebauten Lüftereinheit entspricht. Die Netzteile und Lüftereinheiten sind eindeutig mit einem grünen Pfeil und dem Buchstaben "E" oder einem orangefarbenen Pfeil mit dem Buchstaben "I" gekennzeichnet.
MISE EN GARDE	Veillez à ce que le sens de circulation de l'air du bloc d'alimentation corresponde à celui du tiroir de ventilation installé. Les blocs d'alimentation et les tiroirs de ventilation sont étiquetés d'une flèche verte avec un "E" ou d'une flèche orange avec un "I".
PRECAUCIÓN	Asegúrese de que la dirección del flujo de aire de la unidad de alimentación se corresponda con la de la bandeja del ventilador instalada. Los dispositivos de alimentación y las bandejas del ventilador están etiquetadas claramente con una flecha verde y una "E" o con una flecha naranja y una "I".



CAUTION

If you observe that the switch has powered down approximately two minutes after a power supply replacement, it is likely because the new power supply has a mismatched airflow. Check your console for error messages.

VORSICHT	Falls Sie feststellen, dass der Switch ca. 2 Minuten nach Austausch des Netzteils heruntergefahren wird, ist die mögliche Ursache, dass das neue Netzteil für einen Luftstrom in der falschen Richtung ausgelegt ist. Prüfen Sie auf der Konsole, ob Fehlermeldungen vorliegen.
MISE EN GARDE	Si vous remarquez que le commutateur s'éteint deux minutes après le remplacement d'un bloc d'alimentation, il est probable que le nouveau bloc d'alimentation ait un flux d'air différent de l'ancien. Vérifiez que la console n'affiche aucun message d'erreur.

PRECAUCIÓN	Si observa que el conmutador se ha apagado aproximadamente dos minutos después del cambio de la fuente de alimentación, es posible que se deba a que la nueva fuente de alimentación tenga un flujo de aire incompatible. Revise la consola para ver si hay mensajes de error.
------------	--

**CAUTION**

Disassembling any part of the power supply and fan assembly voids the warranty and regulatory certifications. There are no user-serviceable parts inside the power supply and fan assembly.

VORSICHT	Das Zerlegen von Netzteilen oder Lüftereinheiten macht die Garantie und die gesetzlichen Zertifizierungen ungültig. Die Netzteile und Lüftereinheiten enthalten keine Teile, die vom Benutzer gewartet werden können.
MISE EN GARDE	Le démontage d'une pièce du bloc d'alimentation ou du ventilateur annule la garantie et les certificats de conformité. Aucune pièce du bloc de l'alimentation ou du ventilateur ne peut être réparée par l'utilisateur.
PRECAUCIÓN	Si se desmonta cualquier pieza del módulo de fuente de alimentación y ventiladores, la garantía y las certificaciones normativas quedan anuladas. En el interior del módulo de fuente de alimentación y ventiladores no hay piezas que pueda reparar el usuario.

**CAUTION**

Because the cooling system relies on pressurized air, do not leave any of the power supply and fan assembly slots empty longer than two minutes while the switch is operating. If a power supply or fan assembly fails, leave it in the switch until it can be replaced.

VORSICHT	Das Kühlsystem beruht auf Überdruck. Lassen Sie die Einschübe für Netzteile und Lüfter daher nicht länger als zwei Minuten unbelegt, während der Switch in Betrieb ist. Falls ein Netzteil oder ein Lüfter ausfällt, belassen Sie die Komponente im Switch, bis sie ausgetauscht werden kann.
MISE EN GARDE	Comme le système de refroidissement repose sur l'air pressurisé, ne laissez aucun logement du bloc d'alimentation ou du ventilateur vide plus de deux minutes, lorsque le commutateur est utilisé. Si un bloc d'alimentation ou un ventilateur est défectueux, laissez-le dans le commutateur jusqu'à ce qu'il puisse être remplacé.
PRECAUCIÓN	Como el sistema de refrigeración depende del aire presurizado, no deje ninguna de las ranuras de los módulos de fuente de alimentación y ventiladores vacías durante más de dos minutos mientras el conmutador esté funcionando. Si se produce una avería en el módulo de fuente de alimentación y ventiladores deje el dispositivo en cuestión en el conmutador hasta que lo pueda cambiar.

Electrical cautions

NOTE

The equipment installation must meet NEC/CEC code requirements. Consult local authorities for regulations.

**CAUTION**

Before plugging a cable into any port, be sure to discharge the voltage stored on the cable by touching the electrical contacts to ground surface.

VORSICHT	Bevor Sie ein Kabel in einen Anschluss einstecken, entladen Sie jegliche im Kabel vorhandene elektrische Spannung, indem Sie mit den elektrischen Kontakten eine geerdete Oberfläche berühren.
MISE EN GARDE	Avant de brancher un câble à un port, assurez-vous de décharger la tension du câble en reliant les contacts électriques à la terre.
PRECAUCIÓN	Antes de conectar un cable en cualquier puerto, asegúrese de descargar la tensión acumulada en el cable tocando la superficie de conexión a tierra con los contactos eléctricos.

**CAUTION**

The power supply switch must be in the off position when you insert the power supply into the chassis. Damage to the switch can result if a live power supply is installed.

VORSICHT	Der Schalter des Netzteils muss in der Stellung „Aus“ stehen, wenn das Netzteil in das Gehäuse eingesetzt wird. Wenn ein spannungsführendes Netzteil (Schalterstellung "Ein") eingebaut wird, kann dies zu Beschädigungen am Switch führen.
MISE EN GARDE	Le commutateur d'alimentation doit être en position d'arrêt lorsque vous insérez la source d'alimentation dans le châssis. Si une source d'alimentation sous tension est installée, des dommages peuvent être causés.
PRECAUCIÓN	El interruptor de la fuente de alimentación debe estar en la posición de apagado en el momento de introducirla en el chasis. El conmutador puede resultar dañado si se instala una fuente de alimentación activa.

**CAUTION**

Do not force the installation. If the power supply and fan assembly does not slide in easily, ensure that it is correctly oriented before continuing.

VORSICHT	Wenden Sie beim Einbau keine Gewalt an. Wenn sich ein Netzteil oder eine Lüftereinheit nicht einfach einsetzen lässt, überprüfen Sie zunächst, ob die Ausrichtung korrekt ist.
MISE EN GARDE	Ne forcez pas l'installation. Si le bloc d'alimentation ou le ventilateur ne glisse pas facilement dans leur logement, assurez-vous qu'il soit correctement orienté avant de continuer.
PRECAUCIÓN	No fuerce la instalación. Si el módulo de fuente de alimentación y ventiladores no se deslizan con facilidad hacia el interior, asegúrese de que la orientación sea correcta antes de continuar.

**CAUTION**

All devices with DC power supplies are intended for installation in restricted access areas only. A restricted access area is a location where access can be gained only by trained service personnel through the use of a special tool, lock and key, or other means of security, and is controlled by the authority responsible for the location.

VORSICHT	Alle Geräte mit DC-Netzteil sind nur für die Installation in Bereichen mit beschränktem Zugang gedacht. Ein Bereich mit beschränktem Zugang ist ein Ort, zu dem nur ausgebildetes Wartungspersonal mit Spezialwerkzeug, Schloss und Schlüssel oder anderen Sicherheitsvorrichtungen Zugang hat. Dieser Zugang wird von für den Bereich zuständigen Personen überwacht.
MISE EN GARDE	Tous les équipements dotés de sources d'alimentation C.C. sont destinés à être installés uniquement dans des zones à accès réglementé. Une zone à accès réglementé est une zone dont l'accès n'est possible qu'au personnel de service qualifié utilisant un verrou, une clé ou un outil spécial, ou d'autres moyens de sécurité, et qui est contrôlée par les autorités responsables du site.
PRECAUCIÓN	Todos los dispositivos con fuentes de alimentación de corriente continua (CC) han sido diseñados únicamente para su instalación en áreas restringidas/ zonas de acceso restringido. Se entiende como área de acceso restringido un lugar al que solo puede acceder personal de servicio mediante el uso de una herramienta especial, llave y cerrojo u otro medio de seguridad similar, y que esté controlado por la autoridad responsable de esa ubicación.

**CAUTION**

For the DC input circuit to the system, make sure there is a 10 Amp circuit breaker, maximum 60 VDC, double pole, on the input terminal block to the power supply. The input wiring for connection to the product should be copper wire, 16 AWG, marked VW-1, and rated minimum 90°C.

VORSICHT	Für den Eingangs-Gleichstromkreis zum System ist ein 10 A, maximum -60 V DC, doppelpoliger Stromkreisunterbrecher am Eingang zur Reihenklemme zu installieren. Bei der Eingangsverdrahtung zum Anschluss des Produkts sollte es sich um einen 16 AWG-Kupferdraht (VW-1) und einer Mindestnennntemperatur von 90° C handeln.
MISE EN GARDE	Pour le circuit d'alimentation C.C du système, assurez-vous de la présence d'un disjoncteur de 10 ampères, minimum -60 V C.C., double coupure, sur l'entrée vers le bloc d'alimentation. Les câbles d'alimentation pour le produit doivent être en fils de cuivre, 16 AWG (American Wire Gauge), marqués VW-1 et classés 90 degrés Celsius.
PRECAUCIÓN	Para el circuito de entrada de CC al sistema, verifique que existe un cortacircuitos catalogado de 10 amperios, como mínimo, -60 VCC, bipolar, en la entrada al bloque terminal. El cableado de entrada para la conexión al producto deberá ser de cable de cobre catalogado, 16 AWG, marcado con VW-1, y tener una capacidad nominal mínima para 90 grados centígrados.

**CAUTION**

For a DC system, use grounding wire of at least 16 American Wire Gauge (AWG). The grounding wire should be attached to the DC input connector; the other end connects to the building ground.

VORSICHT	Für ein Gleichstromsystem verwenden Erdungskabel von mindestens 16 AWG (1.31 mm ²) (amerikanische Norm für Drahtquerschnitte). Der Erdungsdraht sollte DC-Eingang angeschlossen werden, das andere Ende verbindet sich mit dem Baugrund.
MISE EN GARDE	Pour les systèmes d'alimentation courant continu (C.C), utilisez un fil de mise à terre d'au moins de 16 AWG (ou 1.31mm ²). Le fil de mise à terre doit être relié au connecteur du circuit d'alimentation; l'autre extrémité se connecte à la prise terre du bâtiment.
PRECAUCIÓN	Para un sistema de CC, usar alambre de puesta a tierra de por lo menos 16 AWG (American Wire Gauge). El cable de tierra debe ser conectada a enchufe CC; el otro extremo se conecta a la tierra del edificio.

**CAUTION**

For the DC input circuit to the system, make sure there is a 20 Amp circuit breaker, minimum 60 VDC, double pole, on the input terminal block to the power supply. The input wiring for connection to the product should be copper wire, 12 AWG, marked VW-1, and rated minimum 90°C.

VORSICHT	Für den Eingangs-Gleichstromkreis zum System ist ein 20 A maximum -60 V DC, doppelpoliger Stromkreisunterbrecher am Eingang zur Reihenklemme zu installieren. Bei der Eingangsverdrahtung zum Anschluss des Produkts sollte es sich um einen 12 AWG-Kupferdraht (VW-1) und einer Mindestnenntemperatur von 90° C handeln.
MISE EN GARDE	Pour le circuit d'alimentation C.C du système, assurez-vous de la présence d'un disjoncteur de 20 ampères, maximum -60 V C.C., double coupure, sur l'entrée vers le bloc d'alimentation. Les câbles d'alimentation pour le produit doivent être en fils de cuivre, 12 AWG (American Wire Gauge), marqués VW-1 et classés 90 degrés Celsius.
PRECAUCIÓN	Para el circuito de entrada de CC al sistema, verifique que existe un cortacircuitos catalogado de 20 amperios, como máximo, -60 VCC, bipolar, en la entrada al bloque terminal. El cableado de entrada para la conexión al producto deberá ser de cable de cobre catalogado, 12 AWG, marcado con VW-1, y tener una capacidad nominal mínima para 90 grados centígrados.

**CAUTION**

For a DC system, use a grounding wire of at least 12 American Wire Gauge (AWG). The 12 AWG wire should be attached to an agency-approved crimp connector crimped with the proper tool.

VORSICHT	Für ein Gleichstromsystem ist ein Erdungsdraht (wenigstens 12 AWG) erforderlich. Ein 12 AWG Draht muss mit dem richtigen Werkzeug an einen zugelassenen Crimpverbinder angebracht werden.
MISE EN GARDE	Pour les systèmes C.C., utilisez un fil de mise à la terre d'au moins 12 AWG (American Wire Gauge). Ce fil de 12 AWG doit être relié à un connecteur à sertissage homologué, serti avec l'outil approprié.
PRECAUCIÓN	Para un sistema de CC, utilice un cable de conexión a tierra de calibre de cable norteamericano (AWG) número 12. El cable 12 AWG deberá acoplarse a un conector engarzado aprobado y engarzado con la herramienta apropiada.

Danger Notices

A Danger statement indicates conditions or situations that can be potentially lethal or extremely hazardous to you. Safety labels are also attached directly to products to warn of these conditions or situations.

Ein Gefahrenhinweis warnt vor Bedingungen oder Situationen die tödlich sein können oder Sie extrem gefährden können. Sicherheitsetiketten sind direkt auf den jeweiligen Produkten angebracht um vor diesen Bedingungen und Situationen zu warnen.

Un énoncé de danger indique des conditions ou des situations potentiellement mortelles ou extrêmement dangereuses. Des étiquettes de sécurité sont posées directement sur le produit et vous avertissent de ces conditions ou situations.

Una advertencia de peligro indica condiciones o situaciones que pueden resultar potencialmente letales o extremadamente peligrosas. También habrá etiquetas de seguridad pegadas directamente sobre los productos para advertir de estas condiciones o situaciones.

General dangers



DANGER

The procedures in this manual are for qualified service personnel.

GEFAHR	Die Vorgehensweisen in diesem Handbuch sind für qualifiziertes Servicepersonal bestimmt.
DANGER	Les procédures décrites dans ce manuel doivent être effectuées par un personnel de maintenance qualifié.
PELIGRO	Los procedimientos de este manual deben llevarlos a cabo técnicos cualificados.

Electrical dangers



DANGER

Disconnect the power cord from all power sources to completely remove power from the device.

GEFAHR	Ziehen Sie das Stromkabel aus allen Stromquellen, um sicherzustellen, dass dem Gerät kein Strom zugeführt wird.
DANGER	Débranchez le cordon d'alimentation de toutes les sources d'alimentation pour couper complètement l'alimentation du dispositif.
PELIGRO	Para desconectar completamente la corriente del instrumento, desconecte el cordón de corriente de todas las fuentes de corriente.



DANGER

Connect the power cord only to a grounded outlet.

GEFAHR	Schließen Sie das Netzkabel nur an eine geerdete Steckdose an.
DANGER	Le cordon d'alimentation ne doit être raccordé qu'à une prise de courant mise à la terre.
PELIGRO	Conecte el cable de alimentación únicamente a una toma de corriente con conexión a tierra.



DANGER

This product is designed for an IT power system with phase-to-phase voltage of 230V. After operation of the protective device, the equipment is still under voltage if it is connected to an IT power system.

GEFAHR	Dieses Produkt ist für die Stromversorgung über ein IT-Stromversorgungssystem mit einer Netzspannung von 230 V Phase zu Phase konzipiert. Bei einem Anschluss an ein IT-Stromversorgungssystem steht das Gerät selbst dann unter Spannung, wenn die Schutzvorrichtung ausgelöst wurde.
DANGER	Ce produit est conçu pour un système d'alimentation électrique avec une tension de 230 Ven mono-phase. Après fonctionnement du dispositif de protection, l'équipement est toujours sous tension s'il est connecté à un système d'alimentation électrique
PELIGRO	Este es un producto diseñado para sistemas de alimentación informático con un voltaje de de haber utilizado el dispositivo de protección, el equipo sigue teniendo voltaje si está conectado a un sistema de alimentación informático.

Dangers related to equipment weight



DANGER

Make sure the rack housing the device is adequately secured to prevent it from becoming unstable or falling over.

GEFAHR	Stellen Sie sicher, dass das Gestell für die Unterbringung des Geräts auf angemessene Weise gesichert ist, so dass das Gestell oder der Schrank nicht wackeln oder umfallen kann.
DANGER	Vérifiez que le bâti abritant le dispositif est bien fixé afin qu'il ne devienne pas instable ou qu'il ne risque pas de tomber.

PELIGRO	Verifique que el bastidor que alberga el instrumento está asegurado correctamente para evitar que pueda hacerse inestable o que caiga.
---------	--

Laser dangers



DANGER

Laser Radiation. Do Not View Directly with Optical Instruments. Class 1M Laser Products.

GEFAHR	Laserstrahlung! Schauen Sie nicht direkt mit optischen Instrumenten in den Laserstrahl herein. Klasse 1M Laserprodukte.
DANGER	Rayonnement de laser. Ne regardez pas directement avec des instruments optiques. Produits de laser de classe 1M.
PELIGRO	Radiacion de Laser. No vea directamente con Instrumentos Opticos. Clase 1M de Productos de Laser.
警告	レーザー放射 光学器具で直接ビームを見ないこと クラス1 M レーザ製品



DANGER

All fiber-optic interfaces use Class 1 lasers.

GEFAHR	Alle Glasfaser-Schnittstellen verwenden Laser der Klasse 1.
DANGER	Toutes les interfaces en fibre optique utilisent des lasers de classe 1.
PELIGRO	Todas las interfaces de fibra óptica utilizan láser de clase 1.