

ExtremeSwitching VDX 8770-4 Hardware Installation Guide

Legal Notice

Extreme Networks, Inc. reserves the right to make changes in specifications and other information contained in this document and its website without prior notice. The reader should in all cases consult representatives of Extreme Networks to determine whether any such changes have been made.

The hardware, firmware, software or any specifications described or referred to in this document are subject to change without notice.

Trademarks

Extreme Networks and the Extreme Networks logo are trademarks or registered trademarks of Extreme Networks, Inc. in the United States and/or other countries.

All other names (including any product names) mentioned in this document are the property of their respective owners and may be trademarks or registered trademarks of their respective companies/owners.

For additional information on Extreme Networks trademarks, please see: www.extremenetworks.com/company/legal/trademarks

Open Source Declarations

Some software files have been licensed under certain open source or third-party licenses. End-user license agreements and open source declarations can be found at: www.extremenetworks.com/support/policies/software-licensing

Contents

Preface.....	9
Conventions.....	9
Notes, cautions, and warnings.....	9
Text formatting conventions.....	9
Command syntax conventions.....	10
Documentation and Training.....	10
Training.....	10
Getting Help.....	10
Subscribing to Service Notifications.....	11
Providing Feedback to Us.....	11
About This Document.....	13
Supported hardware and software.....	13
What's new in this document.....	13
Product Overview.....	15
Product features.....	15
Hardware components.....	16
Port side view.....	17
Nonport side view.....	17
Supported transceivers.....	18
Supported Line cards.....	19
Breakout mode.....	19
Trunking.....	19
27x40 GbE operating modes.....	20
Chassis slots.....	21
Port numbering.....	21
12x40 GbE port numbering.....	21
48x1 GbE and 48x10 GbE port numbering.....	22
48x10G-T port numbering.....	22
27x40 GbE port numbering.....	22
6x100 GbE port numbering.....	22
CFP2 to QSFP28 Conversion Module.....	23
High availability.....	24
Upgrading device firmware.....	24
Preparing for Installation.....	25
Installation and safety considerations.....	25
Environmental requirements.....	26
NEBS requirements.....	27
Time and items required for the installation.....	28
Items included with the device.....	29
Mounting the Device.....	31
Mounting options.....	31
Mounting precautions.....	31
Unpacking, transporting, and installing the device.....	32
Installing the 8U Chassis Flush Mount Rack Kit for Four-Post Racks (XBR-RMK-FL-4).....	33

Time and items required.....	33
Parts list.....	34
Assembling the rack hardware.....	35
Install the device in the rack.....	37
Four-Post Flush and Recessed Mount Intake Air Duct Rack Kit Installation (XBR-RMK-FL-4DS-2 and XBR-RMK-RE-4DS-2).....	39
Safety precautions	39
Time and items required.....	40
Parts list.....	40
Torque requirements.....	42
Installing the flush mount Intake Air Duct kit.....	43
Installing the recessed mount Intake Air Duct kit.....	51
Installing the 8U Chassis Flush and Mid-Mount Rack Kit for Two-Post Racks (XBR-RMK-TELCO-4).....	60
Installation requirements.....	60
Time and items required.....	60
Parts list.....	60
Flush-mounting the device in the rack.....	62
Mid-mounting the device in the rack.....	64
Initial Configuration.....	71
Configuration overview.....	71
Configuration tasks.....	72
Providing power to the device.....	73
Connecting an AC power cord.....	73
Connecting a DC power cord.....	73
Establishing a serial connection to the device.....	74
Logging in to the serial console port.....	75
Assigning permanent passwords.....	76
Changing the default account passwords	76
Configuring the IP addresses.....	76
Setting a static IP address.....	77
Logging off the serial console port and disconnecting the serial cable.....	78
Establishing an Ethernet connection.....	78
Customizing a host name.....	78
Customizing a chassis name.....	79
Setting the date and time.....	79
Time zones.....	80
Time synchronization.....	80
Synchronizing local time using NTP.....	80
Setting the time zone.....	81
Setting the clock (date and time).....	81
Changing the RBridge ID and VCS ID.....	81
Configuring operating modes on 27x40 GbE line cards.....	82
Displaying operating modes.....	83
Verifying correct operation.....	83
Backing up a running configuration.....	83
Connecting network devices.....	84
Connecting to Ethernet devices.....	84
Connecting to workstations, servers, or routers.....	84
Connecting a network device to a fiber port.....	84
Testing connectivity.....	84
Installing transceivers and attaching cables.....	84

Installing SFP and SFP+ transceivers and cables.....	85
Installing QSFP transceivers and cables.....	85
Managing cables.....	86
System Monitoring.....	87
System Monitoring overview.....	87
Determining the status of a line card.....	87
Locating the LEDs on the line card.....	87
Interpreting the line card LED indicators.....	92
Determining the status of a management module.....	94
Locating the LED indicators on the management module	95
Interpreting the management module LED patterns.....	95
Determining the status of a switch fabric module.....	96
Locating the LED indicators on the switch fabric module.....	96
Interpreting the switch fabric module LED indicators.....	96
Determining the status of a power supply.....	97
Locating the alarm LED on the power supply.....	97
Verifying the power supply status.....	98
Determining the status of a fan.....	99
Determining the status of a CID card.....	100
Removal and Replacement Procedures.....	101
Introduction.....	101
ESD precautions.....	101
Cable management comb removal and replacement.....	102
Time and items required.....	102
Removing a cable management comb.....	102
Replacing a cable management comb.....	103
Line card removal and replacement.....	103
Time and items required.....	103
Removing a line card.....	103
Replacing a line card.....	105
CFP2 to QSFP28 Conversion Module removal and replacement.....	106
Removing a CFP2 to QSFP28 conversion module.....	106
Replacing a CFP2 to QSFP28 conversion module.....	106
Management module removal and replacement.....	108
Time and items required.....	108
Faulty management module indicators.....	109
Recording critical configuration information.....	109
Removing a management module.....	109
Replacing a management module.....	110
Switch fabric module removal and replacement.....	110
Time and items required.....	111
Removing a switch fabric module.....	111
Replacing a switch fabric module.....	112
Power supply removal and replacement.....	113
Time and items required.....	113
Removing an AC power supply.....	113
Replacing an AC power supply.....	114
Removing a DC power supply.....	115
Replacing a DC power supply.....	115

Fan removal and replacement.....	116
Time and items required.....	116
Removing a fan	116
Replacing a fan	117
Air filter removal and replacement.....	117
Time and items required.....	118
Removing an air filter.....	118
Replacing an air filter.....	119
Module filler panel removal and replacement.....	119
Removing a filler panel.....	119
Replacing a filler panel.....	119
Chassis ID card removal and replacement.....	120
SFP transceiver removal and replacement.....	120
Time and items required.....	121
Removing a transceiver.....	121
Replacing a transceiver.....	122
QSFP transceiver removal and replacement.....	122
Removing a QSFP transceiver.....	123
Replacing a QSFP transceiver.....	123
Cable routing table.....	123
Air filter removal and replacement.....	124
ExtremeSwitching VDX 8770 Technical Specifications.....	127
System specifications.....	127
Ethernet.....	127
LEDs.....	128
Other.....	128
Weight and physical dimensions.....	128
Environmental requirements.....	129
Power supply specifications (per PSU).....	130
Power consumption (typical configuration).....	130
Power consumption (maximum configuration).....	130
Power consumption (modules).....	131
Data port specifications (Ethernet).....	131
Serial port specifications (pinout RJ-45).....	132
Serial port specifications (protocol).....	132
Memory specifications.....	132
Regulatory compliance (EMC).....	132
Regulatory compliance (safety).....	133
Regulatory compliance (environmental).....	133
Regulatory Statements.....	135
BSMI statement (Taiwan).....	135
Canadian requirements.....	135
CE statement.....	135
China ROHS.....	136
Federal Communications Commission (FCC) Notice.....	136
KCC statement (Republic of Korea).....	136
Japan (VCCI Class A).....	137
Japan power cord	137
Cautions and Danger Notices.....	139

Cautions.....	139
General cautions.....	139
Electrical cautions.....	139
Danger Notices.....	142
General dangers.....	142
Electrical dangers.....	143
Dangers related to equipment weight.....	144
Laser dangers.....	145

Preface

- Conventions..... 9
- Documentation and Training..... 10
- Getting Help..... 10
- Providing Feedback to Us..... 11

This section discusses the conventions used in this guide, ways to provide feedback, additional help, and other Extreme Networks® publications.

Conventions

This section discusses the conventions used in this guide.

Notes, cautions, and warnings

Notes, cautions, and warning statements may be used in this document. They are listed in the order of increasing severity of potential hazards.

NOTE

A Note provides a tip, guidance, or advice, emphasizes important information, or provides a reference to related information.

ATTENTION

An Attention statement indicates a stronger note, for example, to alert you when traffic might be interrupted or the device might reboot.



CAUTION

A Caution statement alerts you to situations that can be potentially hazardous to you or cause damage to hardware, firmware, software, or data.



DANGER

A Danger statement indicates conditions or situations that can be potentially lethal or extremely hazardous to you. Safety labels are also attached directly to products to warn of these conditions or situations.

Text formatting conventions

Text formatting conventions such as boldface, italic, or Courier font may be used to highlight specific words or phrases.

Format	Description
bold text	Identifies command names. Identifies keywords and operands. Identifies the names of GUI elements.
<i>italic text</i>	Identifies text to enter in the GUI. Identifies emphasis. Identifies variables. Identifies document titles.

Format	Description
Courier font	Identifies CLI output.
	Identifies command syntax examples.

Command syntax conventions

Bold and italic text identify command syntax components. Delimiters and operators define groupings of parameters and their logical relationships.

Convention	Description
bold text	Identifies command names, keywords, and command options.
<i>italic text</i>	Identifies a variable.
[]	Syntax components displayed within square brackets are optional.
	Default responses to system prompts are enclosed in square brackets.
{ x y z }	A choice of required parameters is enclosed in curly brackets separated by vertical bars. You must select one of the options.
x y	A vertical bar separates mutually exclusive elements.
< >	Nonprinting characters, for example, passwords, are enclosed in angle brackets.
...	Repeat the previous element, for example, <i>member[member...]</i> .
\	Indicates a "soft" line break in command examples. If a backslash separates two lines of a command input, enter the entire command at the prompt without the backslash.

Documentation and Training

To find Extreme Networks product guides, visit our documentation pages at:

Current Product Documentation	www.extremenetworks.com/documentation/
Archived Documentation (for earlier versions and legacy products)	www.extremenetworks.com/support/documentation-archives/
Release Notes	www.extremenetworks.com/support/release-notes
Hardware/Software Compatibility Matrices	https://www.extremenetworks.com/support/compatibility-matrices/
White papers, data sheets, case studies, and other product resources	https://www.extremenetworks.com/resources/

Training

Extreme Networks offers product training courses, both online and in person, as well as specialized certifications. For more information, visit www.extremenetworks.com/education/.

Getting Help

If you require assistance, contact Extreme Networks using one of the following methods:

- Extreme Portal** Search the GTAC (Global Technical Assistance Center) knowledge base, manage support cases and service contracts, download software, and obtain product licensing, training, and certifications.
- The Hub** A forum for Extreme Networks customers to connect with one another, answer questions, and share ideas and feedback. This community is monitored by Extreme Networks employees, but is not intended to replace specific guidance from GTAC.
- Call GTAC** For immediate support: 1-800-998-2408 (toll-free in U.S. and Canada) or +1 408-579-2826. For the support phone number in your country, visit: www.extremenetworks.com/support/contact

Before contacting Extreme Networks for technical support, have the following information ready:

- Your Extreme Networks service contract number and/or serial numbers for all involved Extreme Networks products
- A description of the failure
- A description of any action(s) already taken to resolve the problem
- A description of your network environment (such as layout, cable type, other relevant environmental information)
- Network load at the time of trouble (if known)
- The device history (for example, if you have returned the device before, or if this is a recurring problem)
- Any related RMA (Return Material Authorization) numbers

Subscribing to Service Notifications

You can subscribe to email notifications for product and software release announcements, Vulnerability Notices, and Service Notifications.

1. Go to www.extremenetworks.com/support/service-notification-form.
2. Complete the form with your information (all fields are required).
3. Select the products for which you would like to receive notifications.

NOTE

You can modify your product selections or unsubscribe at any time.

4. Click **Submit**.

Providing Feedback to Us

Quality is our first concern at Extreme Networks, and we have made every effort to ensure the accuracy and completeness of this document. We are always striving to improve our documentation and help you work better, so we want to hear from you! We welcome all feedback but especially want to know about:

- Content errors or confusing or conflicting information.
- Ideas for improvements to our documentation so you can find the information you need faster.
- Broken links or usability issues.

If you would like to provide feedback to the Extreme Networks Information Development team, you can do so in two ways:

- Use our short online feedback form at <https://www.extremenetworks.com/documentation-feedback/>.
- Email us at documentation@extremenetworks.com.

Please provide the publication title, part number, and as much detail as possible, including the topic heading and page number if applicable, as well as your suggestions for improvement.

About This Document

- Supported hardware and software.....13
- What's new in this document..... 13

Supported hardware and software

This document includes information specific to the ExtremeSwitching VDX 8770-4 device running Extreme Network OS version 7.0.0 and later.

The VDX 8770-4 was first supported at Extreme Network OS version 3.0.0.

What's new in this document

This is a new document.

NOTE

Fibre Channel (FC) is no longer supported. However, instances of "FC" and "FCoE" (Fibre Channel over Ethernet) may still appear in CLI "show" outputs and elsewhere.

Product Overview

• Product features.....	15
• Hardware components.....	16
• Supported transceivers.....	18
• Supported Line cards.....	19
• Chassis slots.....	21
• Port numbering.....	21
• CFP2 to QSFP28 Conversion Module.....	23
• High availability.....	24
• Upgrading device firmware.....	24

Product features

The device described in this guide is part of the Extreme Networks Next Generation Data Center Networks product line, a highly robust class of network switching platforms that combines breakthrough performance, scalability, and energy efficiency with long-term investment. These chassis are designed to address the data growth and application demands of evolving enterprise data centers.

The device features the Extreme CloudPlex™ architecture, a fabric-based Ethernet technology that can present virtual desktops over a global network that integrates both static and cloud-based resources.

A key feature of this device is the Extreme VCS™ technology, which includes virtual cluster switching, a set of technologies that allows users to create flatter, virtualize, and converge data center networks. Extreme VCS fabrics are scalable, permitting users to expand at their own pace, and simplified, allowing users to manage the fabric as a single entity. Extreme VCS-based Ethernet fabrics are convergence-capable with technologies such as Fibre Channel over Ethernet (FCoE) for storage. For more information on Extreme VCS technology and configuring VCS fabrics, refer to the *Extreme Network OS Management Configuration Guide*.

This Extreme device can also be deployed in IP fabrics. An IP fabric can be described as a collection of discrete Layer 3 elements (such as switch-routers) arranged in a spine-leaf network. These elements exchange Layer 2 and Layer 3 database information to provide a flexible, nonblocking and scalable framework while retaining the semantics of a single logical switch. There can be competing protocols for exchanging this distributed database across such discrete elements. Spine-leaf networks are designed to be a three-stage architecture, an ingress stage, a middle stage, and an egress stage. The concept is that there are multiple paths for the call to be switched through the network so that traffic can always connect and not be blocked. For full details and configuration procedures for IP fabrics, refer to the *Extreme Network OS IP Fabrics Configuration Guide*.

The Extreme device includes the following key features:

- A variety of external port types and speeds for supported line card modules. For details on supported transceivers for all ExtremeSwitching VDX 8770 line cards, refer to the *ExtremeSwitching VDX Transceiver Support Matrix*. Access the matrix on the www.extremenetworks.com website by selecting the *Product and Services* tab, and then *Transceivers*. Also contact your Extreme Networks representative for current transceiver support and ordering information.
- Dual, redundant management modules (MMs).
- Up to six switch fabric modules (SFMs).
- Up to eight redundant, hot-swappable power supplies at 220 VAC or -48 VDC.
- Up to four hot-swappable fan modules.
- Serial (console), Ethernet, and USB connections for management modules.

NOTE

USB support is for Extreme-branded USB devices only.

- NEBS-compliant chassis.
- Support for in-band management.
- 15U form factor for chassis.
- Support for Extreme Trunking through the 48x10 GbE and 48x10G-T line card modules.
- Support for Fibre Channel over Ethernet (FCoE).

Hardware components

The device features a modular and scalable mechanical construction that allows a wide range of flexibility in installation, fabric design, and maintenance. The minimum chassis configuration is one management module (MM), one switch fabric module (SFM), and one line card. The chassis can be mounted with the cables facing the front of the equipment rack and consists of the following components:

- Four slots for hot-swappable line cards that can be configured in a single chassis. Depending on the line cards installed, the following ports are available:
 - Up to 192 1/10 Gbps ports for the 48x10 GbE line card.
 - Up to 192 1 Gigabit Ethernet (GbE) ports for the 48x1 GbE line card.
 - Up to 48 40 Gigabit Ethernet (GbE) ports for the 12x40 GbE line card. Up to 384 10 Gbps ports are supported in SFP breakout mode.
 - Up to 24 100 Gigabit Ethernet (GbE) ports for the 6x100 GbE line card.

The 6x100 GbE line cards ship with two base 100 Gigabit ports enabled, but can be upgraded to enable six ports through the 100G Port Upgrade license. This upgrade license is supported by Network OS 5.0.0 and later.
 - Up to 192 1/10 Gigabit Base-T Ethernet ports for the 48x10G-T line card.
 - Up to 108 40 Gigabit Ethernet (GbE) ports for the 27x40 GbE line card. Up to 576 10 Gigabit ports are supported in SFP breakout mode.
- Six slots for switch fabric modules that interconnect all line cards.
- Two slots for management modules:
 - A single active management module can control all ports in the chassis.
 - The standby management module takes control of the device if the active management module fails.
- Modular, hot-swappable field-replaceable units (FRUs):
 - 48x10 GbE line card
 - 48x1 GbE line card
 - 12x40 GbE line card
 - 6x100 GbE line card
 - 48x10G-T line card
 - 27x40 GbE line card
 - Two fan assemblies
 - Up to four 3000W power supplies, 200-240 VAC auto-sensing or -48 VDC (each power supply connection should be separately fused)
- Cable management comb

NOTE

Device control processors and management modules contain batteries for RTC/NVRAM backup. Do not attempt to replace these batteries. Dispose of hardware components containing these batteries as required by local ordinances and regulations.

Port side view

NOTE

Airflow in the Extreme Networks device is from the port side to the rear (fan side) of the chassis.

The following figure displays a sample configuration of the port side of the Extreme Networks device.

FIGURE 1 Port side of the device (sample configuration)

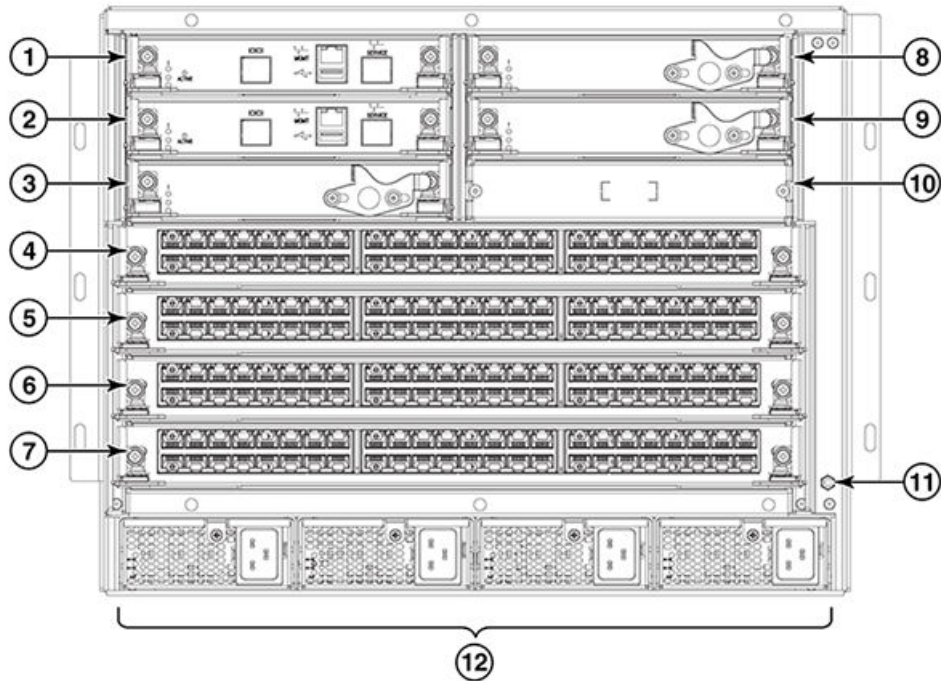

- | | |
|--------------------------------|---|
| 1. Management module slot 1 | 7. Line card slot 4 |
| 2. Management module slot 2 | 8. Switch fabric module slot 2 |
| 3. Switch fabric module slot 1 | 9. Switch fabric module slot 3 |
| 4. Line card slot 1 | 10. Blank slot - unused |
| 5. Line card slot 2 | 11. ESD jack |
| 6. Line card slot 3 | 12. Power supplies (1-4, left to right) |

Nonport side view

The following figure shows a sample configuration of the nonport side view of the Extreme Networks device.

FIGURE 2 Nonport side of the device (sample configuration)

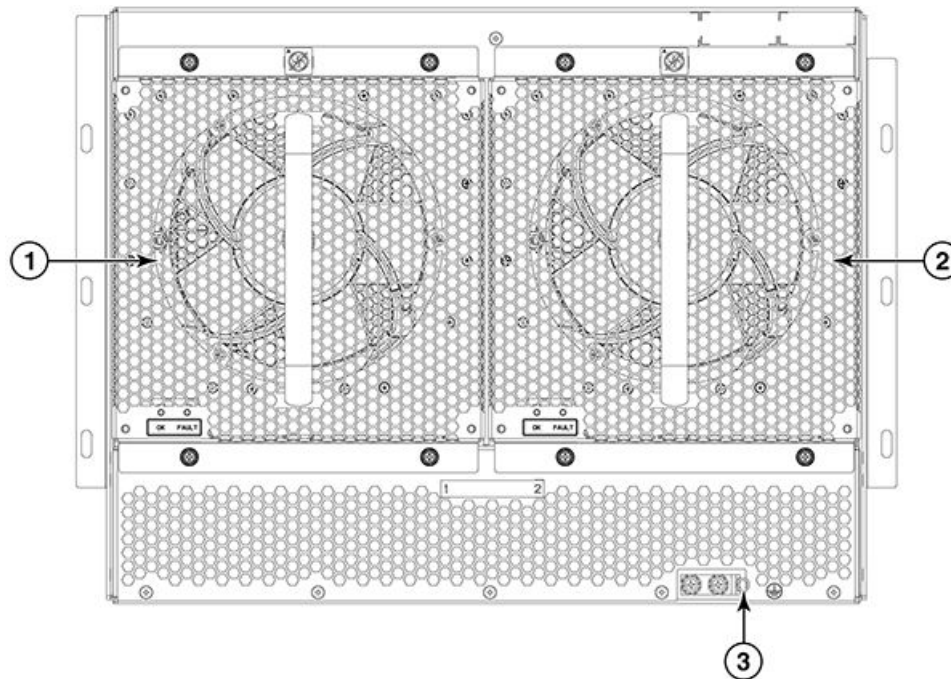

1. Fan #1
2. Fan #2

3. Ground lug

Supported transceivers

Transceiver support depends on the installed line card. For more information on these line cards, refer to the "hardware components" and "line cards" sections of this hardware installation guide.

- 48x10 GbE line cards support 10 GbE SFP+ and 1 GbE SFP optical transceivers, as well as 1 GbE copper SFP transceivers. These line cards also support direct-attach 10 GbE active optical and copper twinaxial (twinax) cables.
- 48x10G-T line cards support fixed 10 GbE Base-T (RJ-45) copper transceivers.
- 48x1 GbE line cards support 1 GbE SFP optical and copper transceivers.
- 12x40 GbE line cards support 40 GbE QSFP optical transceivers. These line cards also support twinax and optical breakout cables for 40 GbE ports.
- 27x40 GbE line cards support 40 GbE QSFP optical transceivers. These line cards also support twinax and optical breakout cables for 40 GbE ports.
- The 6x100 GbE line card supports 100 GbE CFP2 optical transceivers.

The 12x40 and 27x40 line cards also support the Mellanox adapter that allows using a single 10G lane of 4x10G breakout port lanes.

The 48x10 GbE line card also supports tunable SFP+ (TSFP+) 10 GbE transceivers. If used, TSFP+ transceivers must be installed in the port at each end of a link and "tuned" to the same wavelength. If not, the link may come online, but operation may be unpredictable. If wavelength difference exceeds a specified limit, a RASLOG message occurs and the port is taken offline. You can configure wavelengths for installed transceivers using channel numbers from 1 to 102 that correspond to wavelengths from 1568.77 to 1528.38 nm using the **tunable-optics sfpp channel** *channel number* command. For details on using this and related commands, refer to the *Extreme Network OS Management Configuration Guide*.

Additionally, support is available for SFP transceivers that enable you to adapt an SFP slot to a copper GbE interface.

NOTE

The CFP2 to QSFP28 conversion module for the 6x100 GbE line card supports several types of QSFP28 transceivers and optical cable. Refer to [CFP2 to QSFP28 Conversion Module](#) on page 23.

For details on supported transceivers for all ExtremeSwitching VDX 8770 line cards, refer to the *ExtremeSwitching VDX Transceiver Support Matrix*. Access this matrix on the www.extremenetworks.com website by selecting *Product and Services* from the menu, scroll down *Transceivers*, and then select *Transceiver Modules*. Also contact your Extreme Networks representative for current transceiver support and ordering information.

Supported Line cards

The following table summarizes the line cards that are available for the device.

TABLE 1 Supported line cards

Line card	Description
12x40 GbE	12 40 Gbps QSFP Ethernet ports.
48x10 GbE	48 1/10 Gbps Ethernet ports.
48x1 GbE	48 1 Gbps Ethernet ports.
6x100 GbE	Two or six 100 Gbps Ethernet ports depending on licensing.
48x10G-T	48 1/10 Gbps Base-T Ethernet ports
27x40 GbE	27 40 Gbps QSFP Ethernet ports

Breakout mode

Quad SFP (QSFP) 40 Gbps ports on 12x40 GbE and 27x40 GbE line cards can be configured in SFP breakout mode to create four separate 10 Gbps interfaces. You can administer and operate these interfaces as any other SFP port. Special breakout cables provide a connection to the 40 Gbps QSFP port and to four 10 Gbps SFP ports on another device. Twinax active copper cables at 1, 3, and 5 meters and fiber-optic breakout cables are supported.

NOTE

While 40 GbE ports are in breakout mode, port status (individual or as a group) cannot be determined from the port LED state color.

For more information on configuring SFP breakout mode, refer to the *Extreme Network OS Management Configuration Guide*.

Trunking

Extreme Network OS supports Extreme trunks (hardware-based link aggregation groups, or LAGs). These trunks are dynamically formed between two adjacent devices with connected interswitch link (ISL) ports unless trunking is disabled on connecting ports. Traffic is evenly distributed along all links in a trunk. For more information on Extreme trunking and enabling and disabling trunking, refer to the "VCS Fabrics" chapter in the *Extreme Network OS Management Configuration Guide*.

Trunking is supported on GbE interface ports of all line cards.

Port groups

Port groups are established for trunking on supported line cards. To successfully form a trunk from line card ports to another device, select ports from same line card port group and configure each port to operate at the same speed. Following are trunk and port group specifications for supported line cards:

- For the 48x10 GbE line card, up to 8 ports are allowed per trunk. Select ports from octet port groups consisting of ports 1-8, 9-16, 17-24, 25-32, 33-40, and 41-48.
- For the 48x10G-T line card, up to 16 ports are allowed per trunk. Select ports from three port groups consisting of ports 1-16, 17-32, and 33-48.
- For the 12x40 GbE line card, up to two 40GbE ports are allowed per trunk when these ports are configured in breakout mode to provide 10GbE interfaces. Select ports from six port groups consisting of 40GbE ports 1-2, 3-4, 5-6, and 7-8, 9-10, and 11-12.
- For the 27x40 GbE line card, 40GbE ports must be configured in breakout mode to provide 10GbE interfaces for trunking. There are nine port groups consisting of 40GbE ports 1-3, 4-6, 7-9, 10-12, 13-15, 16-18, 19-21, 22-24, and 25-27. The following rules apply to configuring breakout mode and trunking on ports in these groups:
 - You must configure a port group in Performance operating mode. Breakout mode is not supported on ports configured in Density (default) operating mode.
 - When the port group is in Performance mode, you can only configure the first two ports in the port group in breakout mode, since the third port in the group is disabled. Hence, trunking is only supported on the first two ports in the port group.

Trunking two 40 GbE ports

To form an 80 Gbps trunk between two 40 GbE QSFP transceivers on a 40 GbE line card for an ISL connection, use the following steps:

1. Configure each QSFP interface in breakout mode, as if you were connecting four separate 10GE transceivers, then reboot the line card.
2. Use a crossover MTP or MPO 40GE (12-strand) OM3/OM4 Fibre to connect the QSFPs to each other.

For more information on configuring breakout mode and Extreme Trunking, refer to the following:

- "SFP Breakout Mode" in the *Extreme Network OS Management Configuration Guide*.
- "Extreme Trunks" in the *Extreme Network OS Management Configuration Guide*

27x40 GbE operating modes

The 27x40 GbE line card supports nine port groups of three ports each that you can configure for Performance or Density operating modes.

- Performance mode - Because the line card is oversubscribed and cannot support the 40 Gbps line rate on all 27 ports, you can configure *Performance* mode to achieve 40 Gbps rate for up to 18 ports. When a port group is configured In Performance mode, the third port in the port group is persistently disabled, but the remaining two ports operate at up to 40 Gbps to achieve the 80 Gbps maximum rate for the port group. SFP breakout mode is only supported on ports configured in Performance mode.
- Density mode - This is the default mode for all the port groups. In this mode, all the three ports are enabled in each group, but cannot support the 40 Gbps maximum rate. If this mode is configured on all port groups, 27 total ports are available for use.

For configuring operation modes, ID numbers are assigned to each port group sequentially from port 1 through 27 as shown in the following table.

TABLE 2 27x40 GbE line card port groups

Port Group ID	Port Numbers
1	1-3
2	4-6
3	7-9
4	10-12
5	13-15
6	16-18
7	19-21
8	22-24
9	25-27

Port groups for configuring operation modes are illustrated in the following figure. If you configure a port group in Performance mode, the first two ports in a group are enabled for Performance mode. The third port is disabled as it can only be configured in density mode only. If you configure the port group in Density mode, all three ports are enabled for density mode. To identify the port group, use the format *rbridge-id/slot-id/port group-id*. For example, 1/3/9 denotes RBridge 1, slot 3, and port-group-id 9.

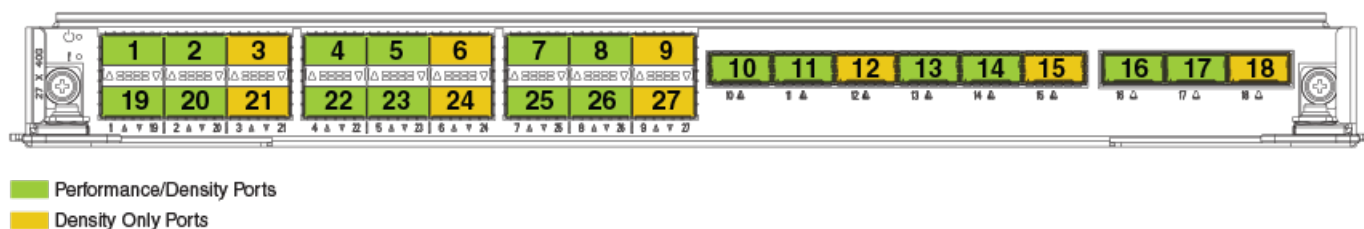
FIGURE 3 Port groups for configuring Performance and Density modes on 27x40 GbE line card

To configure Performance and Density modes for line card port groups using Network OS commands, refer to [Configuring operating modes on 27x40 GbE line cards](#) on page 82.

Chassis slots

Chassis slots are coded and numbered to differentiate between management module slots, switch fabric module slots, and line card slots. Management modules (MMs) must be installed only in slots M1 and M2. switch fabric modules (SFMs) must be installed only in slots S1 through S6. There must be at least one switch fabric module installed in either slot S3 or slot S4. The line card slots, L1 through L8, can be filled with any supported line cards. Unused slots must be filled with the correct filler panels to maintain adequate cooling.

Port numbering

Use the illustrations provided to understand the port numbering for each line card supported on the device.

12x40 GbE port numbering

The following illustration shows the 12x40 GbE line card modules. Ports are numbered 1 through 12 from left to right when installed in the device.

FIGURE 4 12x40 GbE line card



48x1 GbE and 48x10 GbE port numbering

The following illustration shows the 48x1 GbE and 48x10 GbE line card modules. Ports are numbered from 1 through 48, from left to right, with the odd-numbered ports on the upper row and the even-numbered ports on the lower row when installed in the switch.

FIGURE 5 48x10 GbE line card (48x1 GbE line card is similar)



48x10G-T port numbering

The following illustration shows the 48x10G-T line card modules. Ports are numbered from 1 through 48, from left to right, with the odd-numbered ports on the upper row and the even-numbered ports on the lower row when installed in the switch.

FIGURE 6 48x10G-T line card



27x40 GbE port numbering

The following illustration shows the 27x40 GbE line card modules. In the dual-port section, the top row of ports is numbered from 1 through 9 and the lower row of ports is numbered 19 through 27 from left to right when installed on the switch. The single ports on the right of the switch are numbered 10 through 18 from left to right.

FIGURE 7 27x40 GbE line card

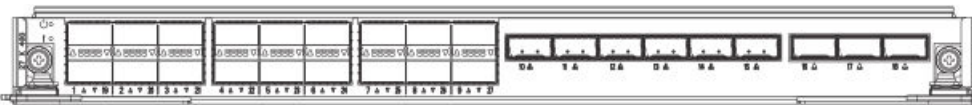

6x100 GbE port numbering

The following illustration shows the 6x100 GbE line card modules. Ports are numbered from 1 through 6, from left to right when installed in the switch.

FIGURE 8 6x100 GbE line card

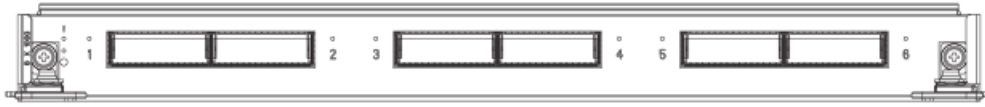

CFP2 to QSFP28 Conversion Module

This section provides general information about the CFP2 to QSFP28 Conversion Module.

NOTE

To install the conversion module, refer to instructions in [Replacing a CFP2 to QSFP28 conversion module](#) on page 106.

The CFP2 to QSFP28 Conversion Module in the following illustration inserts into 100 GbE CFP2 port cages (ports) on the 6x100 GbE line card to allow connection to 100 GbE QSFP28 ports on VDX 6940-144S devices.

FIGURE 9 CFP2 to QSFP28 conversion module

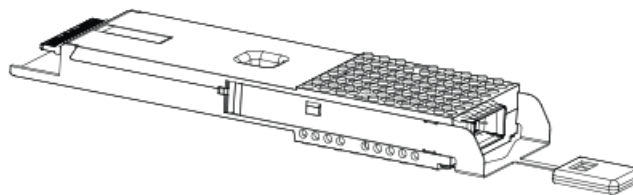

To connect with VDX 6940-144S 100 GbE ports, a QSFP28 transceiver plugs into the conversion module. Use an optical QSFP to QSFP cable with MPO connectors to connect this transceiver to the VDX 6940 ports. Refer to the following illustration.

FIGURE 10 Conversion module with QSFP28 transceiver and cable

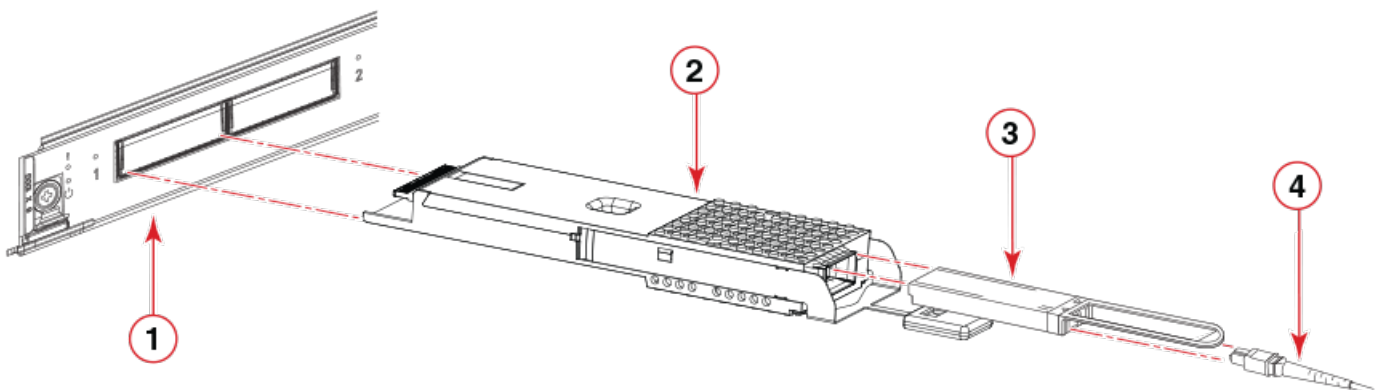

- | | |
|-------------------------------------|---|
| 1. 100 GbE CFP2 port | 3. 100 GbE QSFP28 transceiver |
| 2. CFP2 to QSFP28 Conversion Module | 4. QSFP to QSFP cable with MPO connectors |

100 GbE QSFP28 SR4 optics support Forward error correction (FEC). FEC enhances data reliability by inserting redundant data, called error correcting code, into data being transmitted or stored. FEC is enabled by default on the Extreme Networks QSFP28 SR4 optics.

NOTE

100 GbE QSFP28 transceivers do not support breakout mode.

Use the following QSFP28 transceivers and optical cable for the conversion module:

- QSFP28 LR4, 2Km and 10Km
- QSFP28 SR4
- QSFP28, CWDM4 QSFP28, 2Km
- QSFP to QSFP cable, 10m AOC , with MPO connectors

NOTE

The transceiver used for the conversion module must be a QSFP28 form factor and not QSFP. If a QSFP transceiver is inserted, the port will fault.

The conversion module has a bicolor (green and amber) LED which functions as follows:

TABLE 3 LED descriptions

Color	Status	Recommended action
Amber	Conversion module and QSFP28 transceiver installed in 100 GbE port.	Connect cable to transceiver from VDX 6940-144S 100 GbE port to complete connection.
Green	Cable from VDX 6940-144S is connected to QSFP28 transceiver in conversion module and link is active.	No action

NOTE

LEDs on the line card and line card port function normally when the conversion module is installed in the line card port. Refer to [Interpreting the line card LED indicators](#) on page 92 for details.

High availability

High availability is currently limited to management module configuration synchronization. Failover to the standby module will occur in case of active module failure, but the standby module will go through a cold recovery in which all system components are reset. This will disrupt traffic on the chassis. The reset could take up to eight minutes depending on chassis configuration and traffic load.

Upgrading device firmware

For comprehensive commands and procedures to upgrade Extreme Network OS firmware on this device, refer to the *Extreme Network OS Software Upgrade Guide*.

Preparing for Installation

- Installation and safety considerations.....25
- Time and items required for the installation.....28
- Items included with the device.....29

Installation and safety considerations

Review the following before installing the device:

- Refer to [Cautions and Danger Notices](#) on page 139 to review safety precautions and translations.
- Refer to "NEBS requirements on page 27" to ensure compliance with NEBS-GR-1089 standards
- Refer to the [ExtremeSwitching VDX 8770 Technical Specifications](#) on page 127 to ensure power supply standards are met before installing the chassis and to review the to environmental requirements.
- Refer to "Installation and safety considerations" section to plan for cable management.



DANGER

The procedures in this manual are for qualified service personnel.

NOTE

Extreme Networks strongly recommends that devices be installed in environments that have minimal dust and airborne contaminants.

The following steps are required to ensure correct installation and operation.

1. Ensure that doorways are wider than 91 cm (36 in.) to accommodate the device.
2. Ensure that dedicated electrical branch circuits with the following characteristics are available:
 - Up to four dedicated fused 200-240 VAC, 50-60 Hz feeds or -48 VDC (one per power supply)
 - One cable for each power supply



CAUTION

Use a separate branch circuit for each power cord, which provides redundancy in case one of the circuits fails.

- Protected by a circuit breaker in accordance with local electrical codes
- Supply circuit, line fusing, and wire size adequate to the electrical rating on the device nameplate
- Location close to the device and easily accessible
- Grounded outlets installed by a licensed electrician and compatible with the power cords



DANGER

If the installation requires a different power cord than the one supplied with the device, make sure you use a power cord displaying the mark of the safety agency that defines the regulations for power cords in your country. The mark is your assurance that the power cord can be used safely with the device.

3. Plan for cable management before installing the device.

Cables can be managed in a variety of ways, such as by routing cables below the device, to either side of the device, through cable channels on the sides of the rack, or by using patch panels.

4. Ensure that the following items are available for configuration of the device:
 - Workstation with an installed terminal emulator, such as HyperTerminal
 - Console (serial) cable (provided)
 - Ethernet cables (not provided)
 - Either access to an FTP server or an Extreme USB device for backing up the device configuration or collecting **supportsave** output data (optional)
 - Transceivers (copper and optical) and compatible cables and direct-attach cables if needed
5. Ensure that the air intake and exhaust vents have a minimum of 5.1 cm (2 in.) of airspace.
6. Ensure that the air temperature on the air intake side is less than 40°C (104°F) during operation.



CAUTION

Do not install the device in an environment where the operating ambient temperature might exceed 40°C (104°F).

7. Ensure that the power requirements are met. Refer to the "Technical Specifications" for a listing of power requirements per component.



CAUTION

For the DC input circuit to the system (3000W supply), make sure there is a 80 amp circuit breaker, minimum -48VDC, double pole, on the input lugs to the power supply. The input wiring for connection to the product should be copper wire, 2 AWG, marked VW-1, and rated minimum 90o C.

The power requirements for a given device configuration depend on which modules have been installed in the device. Refer to the [ExtremeSwitching VDX 8770 Technical Specifications](#) on page 127 for information on the power consumption for the modules that can be used in the device along with the power consumption for the cooling fans.

All numbers for the line cards assume that the card is fully populated with transceivers, including QSFPs for the 12x40 GbE and 27x40 GbE line cards. All ports are Ethernet.

You can calculate your power requirements by combining the power demands for the various modules and fan units in your configuration. While you may use fewer ports in a given line card, it is always safer to use the power requirement of a fully populated card.

Environmental requirements

Ensure that the environmental requirements are met. Refer to the [ExtremeSwitching VDX 8770 Technical Specifications](#) on page 127.



CAUTION

Do not install the device in an environment where the operating ambient temperature might exceed 40°C (104°F).

NOTE

The 0° to 40°C (32° to 104°F) range applies to the ambient air temperature at the air intake vents on the port side of the device. The temperature inside the chassis can reach up to 90°C (194°F) for some modules during operation. Extreme Networks recommends that the internal temperature not exceed 75°C (167°F). Cooling policy is based on a combination of ambient temperature and measured temperature on the modules. Various combinations will result in an increase in fan speed to create more cooling in the device. If a component approaches a critical temperature that will trigger a module shutdown, there will be a WARNING message in the RASlog, followed by a CRITICAL message saying that the module will shut down in two minutes. Use the **show environment** command to view temperature status.

NEBS requirements

The following table lists the installation requirements for meeting NEBS GR-1089 compliancy.

TABLE 4 NEBS installation requirements

Reference	Warning, requirement, or statement
Intrabuilding or Intra-connection	WARNING: The intra-building copper Ethernet ports of the equipment or subassembly are suitable for connection to intrabuilding or unexposed wiring or cabling only. The intra-building ports of the equipment or subassembly MUST NOT be metalically connected to interfaces that connect to the outside plant (OSP) or its wiring. These interfaces are designed for use as intra-building interfaces only (Type 2 or Type 4 ports as described in GR-1089-CORE, Issue 6) and require isolation from the exposed OSP cabling. The addition of Primary Protectors is not sufficient protection in order to connect these interfaces metalically to OSP wiring.
First Level Lightning Criteria AC Power Ports	WARNING: The Extreme Networks device must be connected to external Special Protection Devices (SPD) when installed and connected to commercial AC power.
Class A2 Voltage Accessibility	The Extreme device must be located in a restricted access location were only crafts personnel are allowed access.
Class B Voltage Accessibility	The Extreme device must be located in a restricted access location were only crafts personnel are allowed access.
Equipment Grounding Systems	The Extreme Networks device must be installed and connected to the CBN, IBN, or Ether.
Communication Equipment Grounding	The Extreme Networks device is suitable for connection to the Central Office.
Bonding of Battery Return (BR) Input Terminals	The battery returns of the Extreme Networks device must be connected (DC-I).
Connections	The Extreme Networks device must be grounded via a copper ground conductor.
Connections	All bare grounding connection points to the Extreme Networks device must be cleaned and coated with an antioxidant solution before connections are made.
Connections	All surfaces on the Extreme Networks device that are un-plated must be brought to a bright finish and treated with an antioxidant solution before connections are made.
Connections	All non-conductive surfaces on the this device must be removed from all threads and connection points to ensure electrical continuity.
Connections	The VDX 8770 utilizes a two-hole compression type, agency-approved crimped connector with a copper #2 American Wire Gauge (AWG) that utilizes 20 inch pounds of torque to secure it to the frame and EUT.
Input DC Voltage	The VDX 8770 is capable of operating at 200-240 V, 50/60 Hz at a maximum current level of 16.0 A max., or -48VDC, 70.0 A max. per power supply.
Thermal policy	<p>Due to recent changes in the NEBS thermal policy testing procedures, Extreme Networks has made changes to the thermal policy for the VDX 8770. These changes include an additional fan speed (raising the number of fan speeds to 4 from 5) and slightly altered trigger temperatures. Additional non-user visible RASlog message generation has also been included with this change to allow for easier debugging and thermal history recording.</p> <p>The precise values for temperature and fan RPM are related to the specific hardware combinations possible in the modular switch. For the sake of</p>

TABLE 4 NEBS installation requirements (continued)

Reference	Warning, requirement, or statement
	brevity, the following table lists the possible range of values for each heat level.

TABLE 5 NEBS thermal policy levels

Level	Description	Temperature	RPM
1	LOW	up to 25C	2500 RPM
2	MED-LOW	from 25C through 35C	4000 RPM
3	MED	from 36C through 45C	5500 RPM
4	HIGH	from 46C through 55C	7350 RPM
5	MAX	from 56C through 61C	9300 RPM



CAUTION

For the NEBS-compliant installation of an Extreme Networks device, use a ground wire of at least 2 AWG. The ground wire should have an agency-approved crimped connector (provided with the device) attached to one end, with the other end attached to building ground. The connector must be crimped with the proper tool, allowing it to be connected to both ground screws on the enclosure. Before crimping the ground wire into the provided ground lug, ensure that the bare copper wire has been cleaned and antioxidant is applied to the bare wire. In addition, anti-rotation devices or lock washers must be used with all screw connections for the grounding wire.

Time and items required for the installation

You can set up and install the Extreme Networks device in the following ways:

- As a standalone unit on a flat surface
- In a 19-inch Electronic Industries Association (EIA) rack, using the four-post rack mount kit
- In a two-post telecommunications (Telco) rack

The following table describes the installation tasks, the estimated time required for each, and the items required to complete the task based on a fully populated chassis (384 10 GbE ports). Configurations with fewer ports require less time. These time estimates assume a prepared installation site and appropriate power and network connectivity.



DANGER

The procedures in this manual are for qualified service personnel.

TABLE 6 Installation tasks, time, and items required

Installation task	Time estimate	Items required
Site preparation and unpacking the device	30 minutes	#2 Phillips screwdriver Pallet jack. Hydraulic lift or assisted lift, able to raise to a minimum of 140 cm (55 in.), with a minimum capacity of 113 kg (250 lb). To know the weight of your device fully populated with the required port blades, refer to the Technical Specifications at the end of this guide.

TABLE 6 Installation tasks, time, and items required (continued)

Installation task	Time estimate	Items required
Installing rack mount kit	30 minutes	Refer to the rack mount kit instructions for the device.
Mounting and securing the device in rack	30 minutes	
Installing power cables and powering on the device	20 minutes	Power cables (provided in the device accessories kit).
Establishing serial connection, logging on to the device, and configuring the IP addresses.	20 minutes	Serial cable (provided in the accessory kit). Workstation computer with a serial (console) port or terminal server port and a terminal emulator application (such as HyperTerminal). Ethernet IP addresses for the device and for both control processor blade (a total of three addresses).
Installing an Ethernet cable, opening a Telnet session, and configuring the device domain ID, date and time, and additional system parameters. Verify and back up the configuration.	20 minutes	Ethernet cabling (optional) for Telnet access.
Installing transceivers as needed	30 - 60 minutes (up to 30 minutes per transceiver)	Copper and optical transceivers and direct-attach cables as needed
Attaching cables, cable ties, and cable guides	2-3 hours	Cables, cable ties, and cable management comb.

**CAUTION**

All devices with DC power supplies are intended for installation in restricted access areas only. A restricted access area is a location where access can be gained only by trained service personnel through the use of a special tool, lock and key, or other means of security, and is controlled by the authority responsible for the location.

Items included with the device

The basic product (SKUs BR-VDX8770-8-BND-AC or BR-VDX8770-8-BND-DC depending on whether you order AC or DC power supplies) ships with the following items:

- A chassis, populated with:
 - Management modules (one)
 - Switch fabric modules (three)
 - Filler panels for unoccupied slots for all modules
 - Power supplies (up to two)
 - Power supply filler panels for unoccupied bays
 - Fan modules (two)
- An accessory kit containing the following items:
 - Console cable (RJ-45 serial cable: There is also an adapter that can be used to provide a DB9-style connector.)
 - Wrist strap (ESD grounding strap)
 - Ground lug kit
 - SFP extraction tool kit
 - China RoHS guide
 - Cable management comb
 - Extreme Networks branded USB device
 - Power cord retainer kit

Items included with the device

- Hardware for securing the device in a rack
- Web pointer document
- Air filter
- Line cards (up to four) and additional power supplies must be ordered separately.

The rack mount kits must be ordered separately.

Extreme Networks branded transceivers (SFP, SFP+, CFP2, QSFP, or 10Base-T) and cables or direct-attach cables must also be ordered separately. The VDX 8770-8 supports SR and LR SFP, SFP+, and CFP2 transceivers. QSFP transceivers are SR transceivers only. Twinax active copper and fiber- optic breakout cables are supported.

For details on supported transceivers, refer to the following publications on www.extremenetworks.com:

- *ExtremeSwitching VDX Transceiver Support Matrix.*
- *Extreme Fibre Channel Transceiver Support Matrix.*

Mounting the Device

- [Mounting options](#)..... 31
- [Mounting precautions](#)..... 31
- [Unpacking, transporting, and installing the device](#)..... 32
- [Installing the 8U Chassis Flush Mount Rack Kit for Four-Post Racks \(XBR-RMK-FL-4\)](#)..... 33
- [Four-Post Flush and Recessed Mount Intake Air Duct Rack Kit Installation \(XBR-RMK-FL-4DS-2 and XBR-RMK-RE-4DS-2\)](#)..... 39
- [Installing the 8U Chassis Flush and Mid-Mount Rack Kit for Two-Post Racks \(XBR-RMK-TELCO-4\)](#)..... 60

Mounting options

You can mount the device in the following locations:

- Standalone on a table top or flat surface.
- In a four-post 19 in. (48.3 cm) EIA rack:
 - Use the 8U Chassis Flush Mount Rack Kit for Four-Post Racks (XBR-RMK-FL-4)
 - Refer to [Installing the 8U Chassis Flush Mount Rack Kit for Four-Post Racks \(XBR-RMK-FL-4\)](#) on page 33 for instructions.
- In a four-post 19 in. (48.3 cm) EIA rack using an intake air duct kit:
 - Use the Four-Post Flush Mount Intake Air Duct Rack Kit (XBR-RMK-FL-4DS-2)
 - Use the Four-Post Recessed Mount Intake Air Duct Rack Kit (XBR-RMK-RE-4DS-2)
 - Refer to [Four-Post Flush and Recessed Mount Intake Air Duct Rack Kit Installation \(XBR-RMK-FL-4DS-2 and XBR-RMK-RE-4DS-2\)](#) on page 39.
- In a two-post Telco rack:
 - Use the 8U Chassis Flush and Mid-Mount Rack Kit for Two-Post Racks (XBR-RMK-TELCO-4).
 - Refer to [Installing the 8U Chassis Flush and Mid-Mount Rack Kit for Two-Post Racks \(XBR-RMK-TELCO-4\)](#) on page 60 for instructions.

NOTE

These rack mount kits are supported for this device at the date of this publication. For the latest support information, contact your Extreme Networks representative.

NOTE

Review the [Mounting precautions](#) on page 31 before mounting the device and ensure that all [Environmental requirements](#) on page 26 are met.

Mounting precautions

The following general precautions for mounting the device.



CAUTION

Do not use the port cover tabs to lift the module. They are not designed to support the weight of the module, which can fall and be damaged.



CAUTION

Make sure the airflow around the front, and back of the device is not restricted.



DANGER

Mount the devices you install in a rack as low as possible. Place the heaviest device at the bottom and progressively place lighter devices above.



DANGER

Use safe lifting practices when moving the product.



CAUTION

To prevent damage to the chassis and components, never attempt to lift the chassis using the fan or power supply handles. These handles were not designed to support the weight of the chassis.



CAUTION

Never leave tools inside the chassis.



DANGER

A fully populated Extreme Networks device weighs between 86.18 kg (190 lb) and 165.56 kg (365 lb) and requires a hydraulic or assisted lift to install it.



DANGER

Make sure the rack housing the device is adequately secured to prevent it from becoming unstable or falling over.

Following are specific precautions for mounting the VDX 8770-4:

- Provide a space that is 8 rack units (8U) high, 61.19 cm (24.09 in.) deep, and 43.74 cm (17.22 in.) wide. One rack unit is equal to 4.45 cm (1.75 in.). If you are using the VDX 8770-4 Four-Post Flush and Recessed Mount Intake Air Duct Rack Kit, you will need a space that is 10U high to accommodate both the Intake Air Duct Rack Kit and the switch.
- Plan to install the Extreme Networks device with the port side facing the air-intake aisle. Airflow is from the port side of the device to the fan side. If you are using the Intake Air Duct Rack Kit for mounting the VDX 8770-4, then the airflow is from the port side to the fan side.
- Ensure that the rack is balanced and mechanically secured to provide stability in the event of an earthquake and that the equipment does not exceed the rack's weight limits.

Unpacking, transporting, and installing the device



DANGER

A fully populated Extreme Networks device weighs between 86.18 kg (190 lb) and 165.56 kg (365 lb) and requires a hydraulic or assisted lift to install it.

**DANGER**

Use safe lifting practices when moving the product.

1. Unpack the device.
 - a) Cut the bands that encircle the packaging.
 - b) Slide the upper portion of the cardboard shipping box up off the pallet and shipping tray.

NOTE

The product packaging incorporates a wood pallet and brackets. The device sits on top of a corrugated cardboard shipping tray.

- c) Save the packing materials in the event you need to return the product.
 - d) Leave the device on top of the shipping tray and pallet if the device must be transported to the installation location.
2. Use a pallet jack or other assisted lift to transport the device to the installation area.
3. Using the rack mount instructions in this Hardware Installation Guide that apply to your device and rack type, install the rack components in the rack and mounting flanges on the device.
4. Remove the accessory kit (cardboard box), packing foam, and anti-static plastic from the device and set them aside.
5. Remove the foam inserts around the base of the device.
6. Use a lift to raise the device to the correct level. If installing the device in a rack, follow the instructions provided by the rack kit manufacturer.
7. If applicable, lock the wheels of the lift.
8. Ensure that the device is oriented so that the port side (front) has access to intake air.
9. Gently slide the device onto the final installation surface, ensuring that it remains supported during the transfer.
10. Before you apply power to the device, you can install the management module, switch fabric module, and line card modules as well as power supplies to speed up your installation.

Installing the 8U Chassis Flush Mount Rack Kit for Four-Post Racks (XBR-RMK-FL-4)

Use the following instructions to install the device in a 19 in. EIA rack with a rail-to-rail depth of 27-31 in. (68.58 to 78.74 cm) using the 8U Chassis Flush Mount Rack Kit for Four-Post Racks (XBR-RMK-FL-4).

Observe the following when mounting this device:

- Use Electronic Industries Association (EIA) standard racks. Provide a space that is 8 rack units (8U) high, 61.19 cm (24.09 in.) deep, and 43.74 cm (17.22 in.) wide. 1U is equal to 4.45 cm (1.75 in.).
- Before mounting your device, review any specific installation and facility requirements in this Hardware Installation Guide.
- Hardware devices illustrated in these procedures are only for reference and may not depict the device you are installing into the rack.

Time and items required

Allow approximately one hour to unpack and install the device in a rack.

The following tools are required when installing the rack mount kit:

- Torque wrench with #2 Phillips screwdriver tip
- Flathead screwdriver
- Hydraulic or assisted lift with a minimum raise of 140 cm (55 in.) and a minimum capacity of 113 kg (250 lbs).

Parts list

The following parts are provided with the 8U Chassis Flush Mount Rack Kit for Four-Post Racks (XBR-RMK-FL-4).

FIGURE 11 Rack kit parts

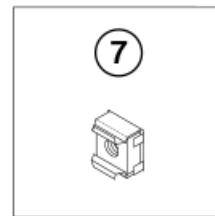
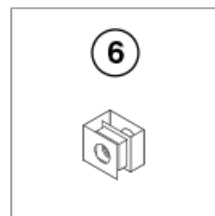
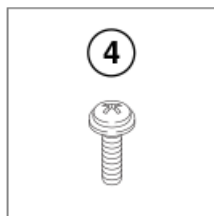
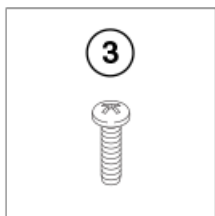
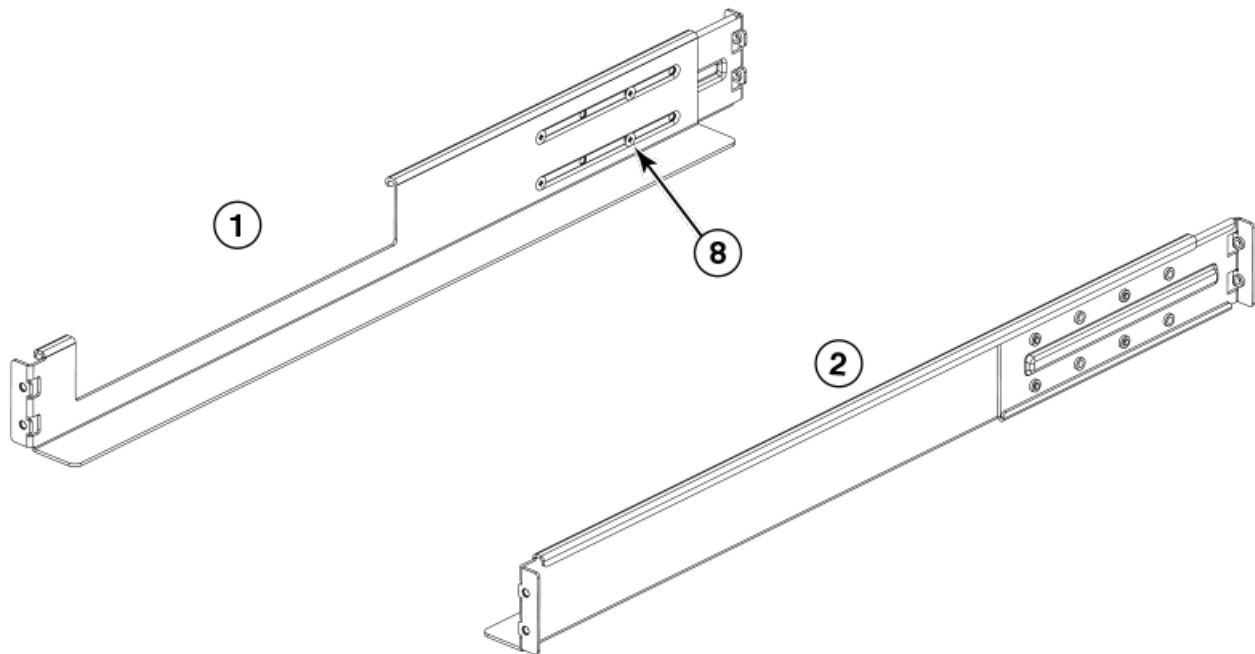

- | | |
|--|--|
| <ol style="list-style-type: none"> 1. Left rail 2. Right rail 3. 10-32 x .31 in. (.79 cm) Phillips screw (16) 4. 10-32 x .63 in.(1.60 cm) Phillips screw with square cone washer for racks that have rails with round holes (18) | <ol style="list-style-type: none"> 5. Alignment washer for racks that have rails with square holes (4) 6. Clip nuts (14) 7. Retainer nuts (14) 8. Adjusting screw locations 6-32 x .25 in. (.635 cm) Phillips screw with patchlock (2) |
|--|--|

NOTE

Not all parts may be used with certain installations depending on the device type.

Assembling the rack hardware

1. Unpack the rack kit hardware.
2. On each rail (1 and 2 in the previous figure), loosen the four screws on the adjustable brackets and adjust the rails to the depth of your rack. Tighten the screws after adjustment.

3. Noting that the rails are designated "Left" and "Right," install each rail in the rack using four 10-32 x .63 screws, two screws on each end of each rail. Refer the previous figure.
 - Position the rails so that the adjustable ends are mounted on the intake aisle side of the rack.
 - For rails with round holes - use two 10-32 x .63 screws with square-cone washers on each end of the rail assembly. Tighten the screws to a torque of 29.2 to 36.5 in-lb (33.6 to 42 cm-kg).
 - For rails with square holes - use the two standard 10-32 x .63 screws with blue Loctite on the threads and alignment washers on each end of the rail assembly. Tighten the screws to a torque of 29.2 to 36.5 in-lb (33.6 to 42 cm-kg).

FIGURE 12 Rack mount rails installed in a four-post rack

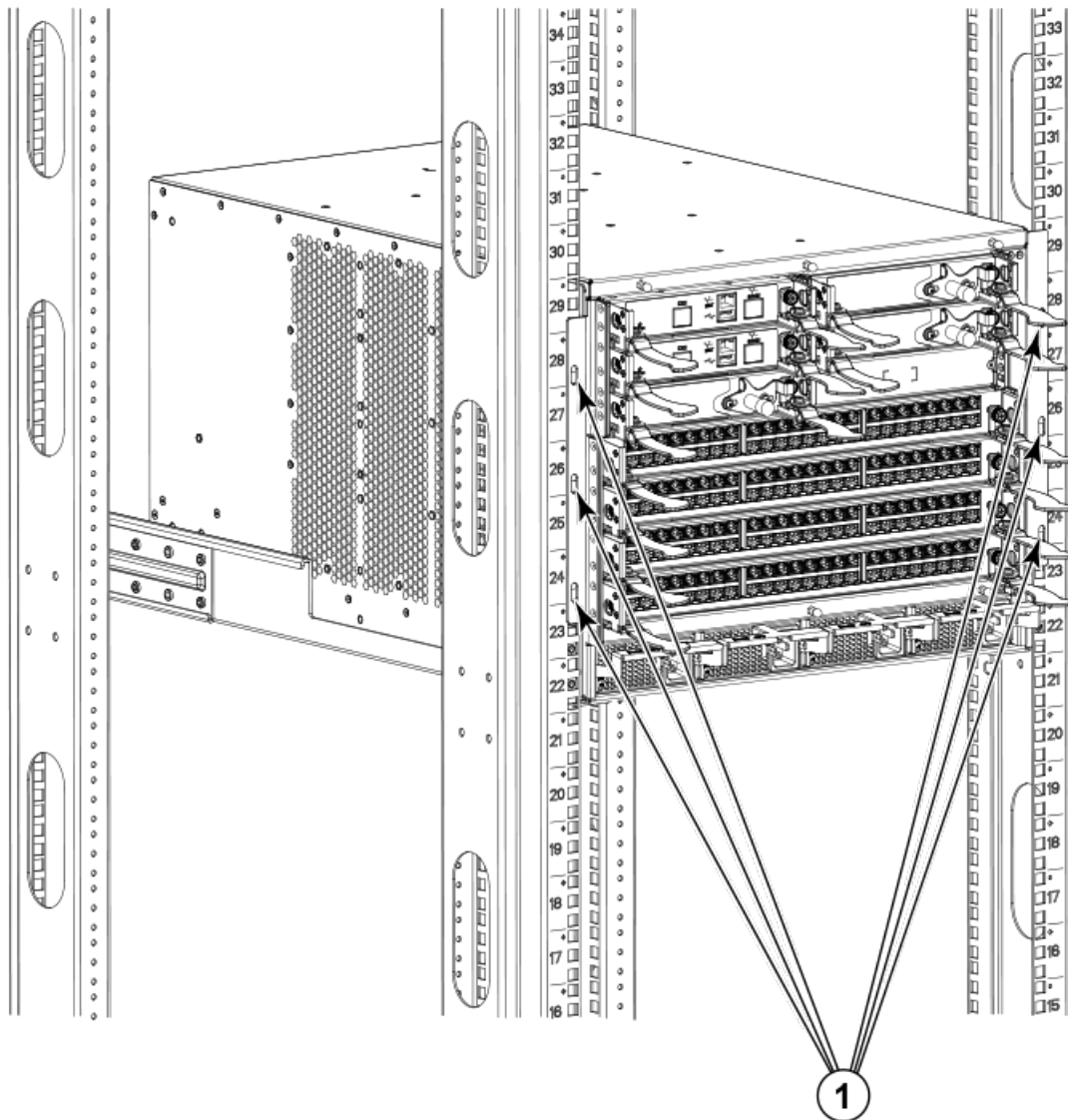

1. 10-32 x .63 in. (1.60 cm) Phillips screws

4. Install either clip nuts or retainer nuts depending on whether your rack has round holes or square holes.

These will allow you to secure the device to the rack posts.

NOTE

For posts with round holes, use the clip nuts on the rack posts for securing 10-32 screws. For posts with square holes, use the retainer nuts. Refer the following figure.

FIGURE 13 Using clip nuts and retainer nuts to secure screws to the rack uprights.

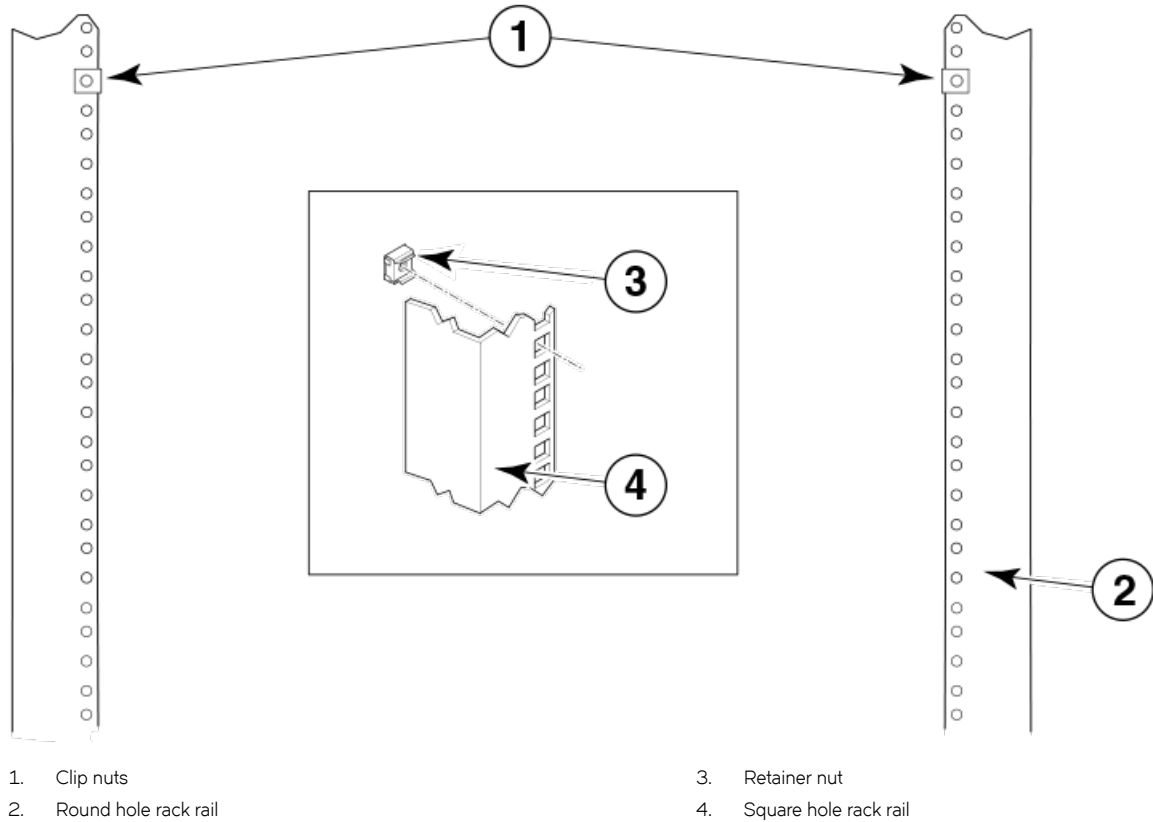

Install the device in the rack



DANGER

Use safe lifting practices when moving the product.

1. Move the lift with the device in front of the rack and adjust the height to match the installed rails.
2. If applicable, lock the wheels of the lift.

3. Gently slide the device onto the rack, ensuring that it remains supported during the transfer. See the following figure.

FIGURE 14 Device installed in the rack

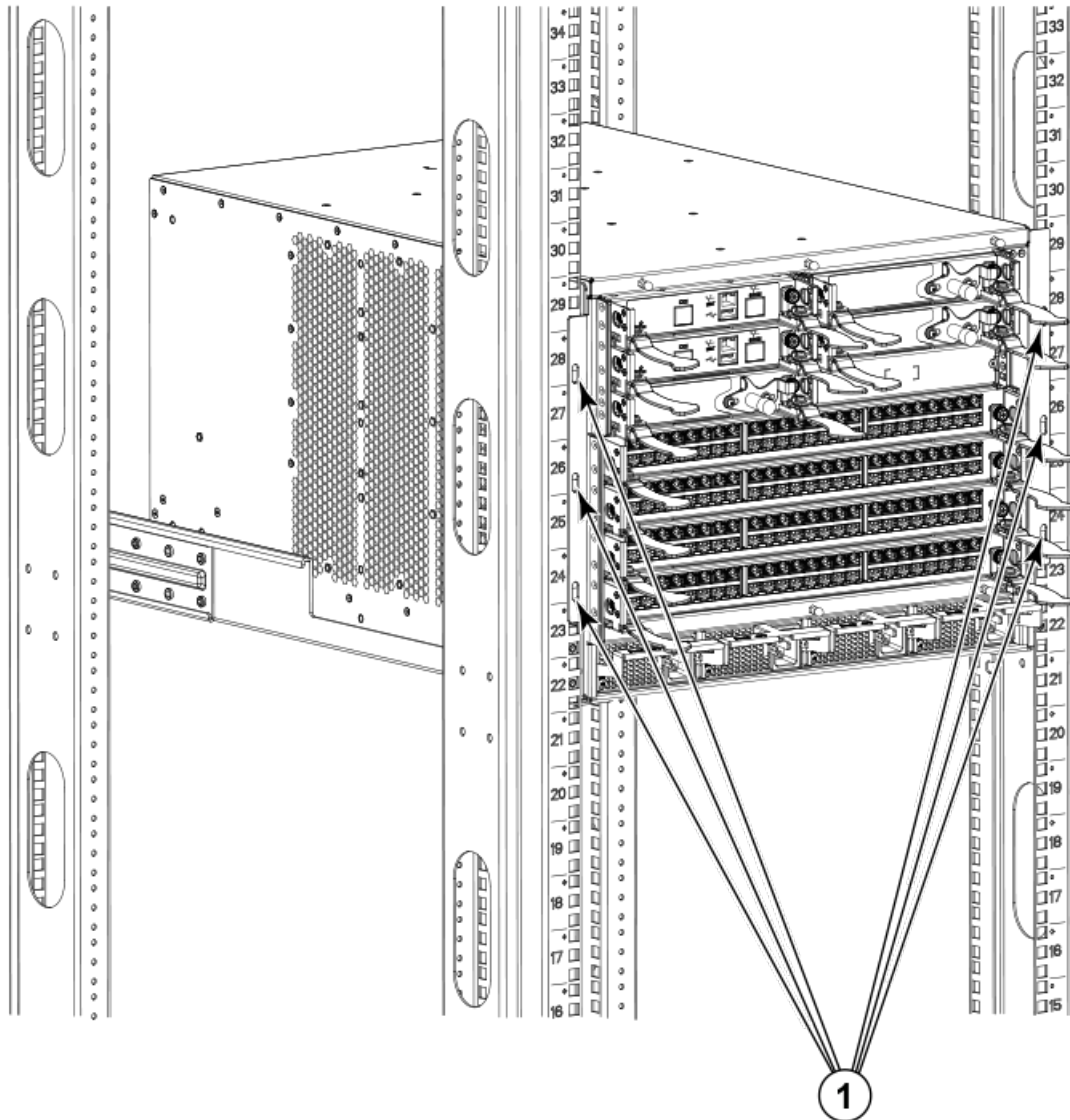

1. Screw locations

4. Secure the device to the equipment rack rails with six 10-32 x .63 screws, three screws on each side. See the previous figure.
5. Tighten the screws to a torque of 29.2 to 36.5 in-lb (33.6 to 42 cm-kg).

Four-Post Flush and Recessed Mount Intake Air Duct Rack Kit Installation (XBR-RMK-FL-4DS-2 and XBR-RMK-RE-4DS-2)

Use the following instructions to install an Intake Air Duct Kit in a 19 in. (48.26 cm) Electronics Industries Association (EIA) rack in either a flush or recessed configuration using one of the following Extreme Intake Air Duct Kits:

- XBR-RMK-FL-4DS-2 - Flush mount kit for rack rail-to-rail depth of 27 to 31 in. (68.58 to 78.74 cm).
- XBR-RMK-RE-4DS-2 - Recessed kit for rail-to-rail depth of 27 to 31 in. (68.58 to 78.74 cm)

Air flows into the Intake Air Duct Kit through the front vent and out through the fans at the rear of the unit.

This Intake Air Duct Kit is required for the following and later-model line cards:

- 48x10GT
- 27x40GbE
- 6x100GbE

Observe the following when mounting this device:

- Before mounting your device, review any specific installation and facility requirements in the Hardware Installation Guide for the device.
- Hardware devices illustrated in these procedures are only for reference and may not depict the device you are installing into the rack.

Safety precautions



DANGER

Use safe lifting practices when moving the product.



DANGER

Mount the devices you install in a rack as low as possible. Place the heaviest device at the bottom and progressively place lighter devices above.



CAUTION

Make sure the airflow around the front, and back of the device is not restricted.



CAUTION

Use the screws specified in the procedure. Using longer screws can damage the device.



CAUTION

Never leave tools inside the chassis.



CAUTION

Do not use the port cover tabs to lift the module. They are not designed to support the weight of the module, which can fall and be damaged.



CAUTION

To prevent damage to the chassis and components, never attempt to lift the chassis using the fan or power supply handles. These handles were not designed to support the weight of the chassis.

Time and items required

Allow approximately one hour to unpack and install the air duct kit in a rack.

The following tools are required when installing the air duct kit:

- Torque wrench with #2 Phillips screwdriver tip
- Flathead screwdriver

Parts list

The following parts are provided with the 8U Chassis Flush and Recessed Mount Intake Air Duct Kit for Four-Post Racks (XBR-RMK-RE-4DS-2 and XBR-RMK-FL-4DS-2). The parts list varies on whether you use the flush mount or recessed mount version of the kit.

FIGURE 15 Items in the flush mount Intake Air Duct kit

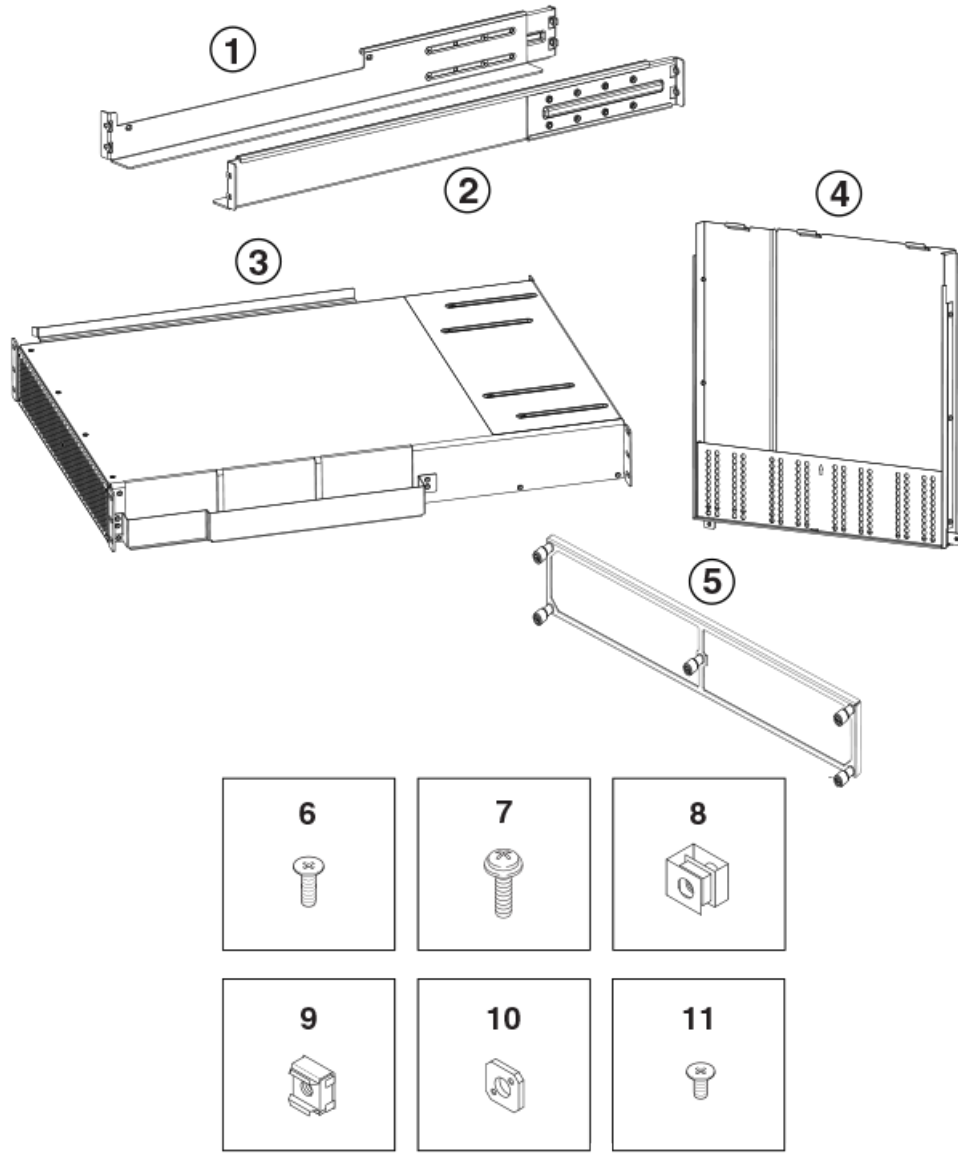

- | | |
|--|---|
| <ul style="list-style-type: none"> 1. Left rail 2. Right rail 3. Top intake assembly 4. Side duct 5. Air filter 6. 10-32 x .31 in. (.79 cm) Phillips screw with blue Loctite on threads (16) | <ul style="list-style-type: none"> 7. 10-32 x .63 in. (1.60 cm) Phillips screw with square cone washer for racks that have rails with round holes (18) 8. 10-32 clip nut for racks that have rails with round holes (14) 9. 10-32 retainer nut for racks that have rails with square holes (14) 10. Alignment washer for racks that have rails with square holes (4) 11. 6-32 x .25 in. (.635 cm) Phillips screw (2) |
|--|---|

FIGURE 16 Items in the recessed mount Intake Air Duct kit

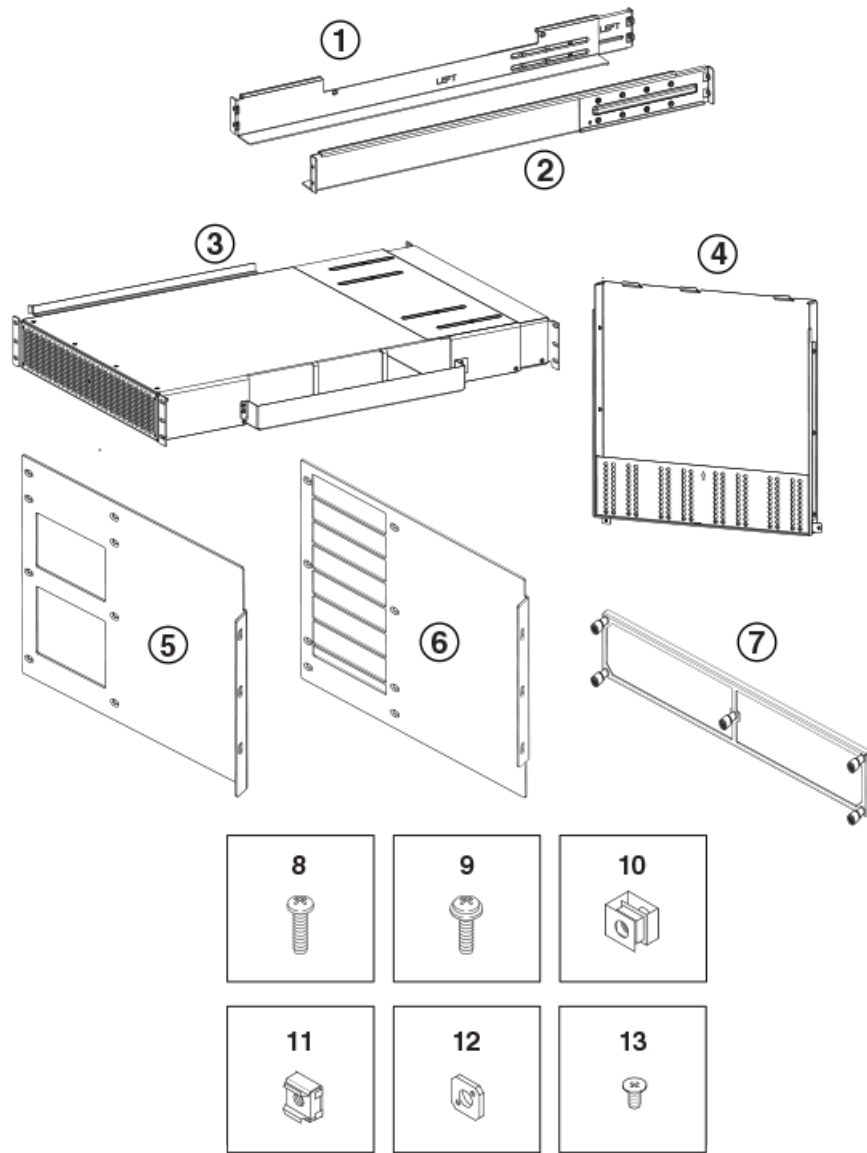

- | | |
|---|--|
| <ul style="list-style-type: none"> 1. Left rail 2. Right rail 3. Top intake assembly 4. Side duct 5. Left recessed rack ear 6. Right recessed rack ear 7. Air filter | <ul style="list-style-type: none"> 8. 10-32 x .31 in. (.79 cm) Phillips screw with blue Loctite on threads (16) 9. 10-32 x .63 in.(1.60 cm) Phillips screw with square cone washer for racks that have rails with round holes (18) 10. 10-32 clip nut for racks that have rails with round holes (14) 11. 10-32 retainer nut for racks that have rails with square holes (14) 12. Alignment washer for racks that have rails with square holes (4) 13. 6-32 x .25 in. (.635 cm) Phillips screw (2) |
|---|--|

Torque requirements

Use the following torque settings when tightening screws that secure the rack mount kit and Intake Air Duct Kit to the equipment rack.

TABLE 7 Torque requirements

Screw size	Torque
6-32 x .25 in. (.635 cm) Phillips screw	8.75 in-lb (10 cm-kg)
10-32 x .63 in.(1.60 cm) Phillips screw	32 in-lb (36.86 cm-kg)

Installing the flush mount Intake Air Duct kit

Use the following procedure to install the flush mount Intake Air Duct kit.

NOTE

After you unpack the kit, check the contents required for this installation against the parts list in [Figure 15](#) on page 41. This hardware kit is a universal kit, and not all hardware is used for this installation.

Installing the rack hardware

- Determine how the device can be oriented in the equipment rack so that the port side has access to intake (cool) air.

NOTE

Be sure to allow for an additional 1U rack space above where you will install the top intake assembly to provide clearance for raising the intake and inserting it on to side duct tabs. Refer to [Step 6](#).

- Install either clip nuts or retainer nuts depending on whether your rack has round holes or square holes. These allows you to secure the device to the rack posts.

NOTE

For posts with round holes, use the clip nuts on the rack uprights for securing M6 x 1.0 x 12 screws. For posts with square holes, use the retainer nuts. Refer to the following figure.

FIGURE 17 Using clip nuts or retainer nuts to secure screws to the rack posts

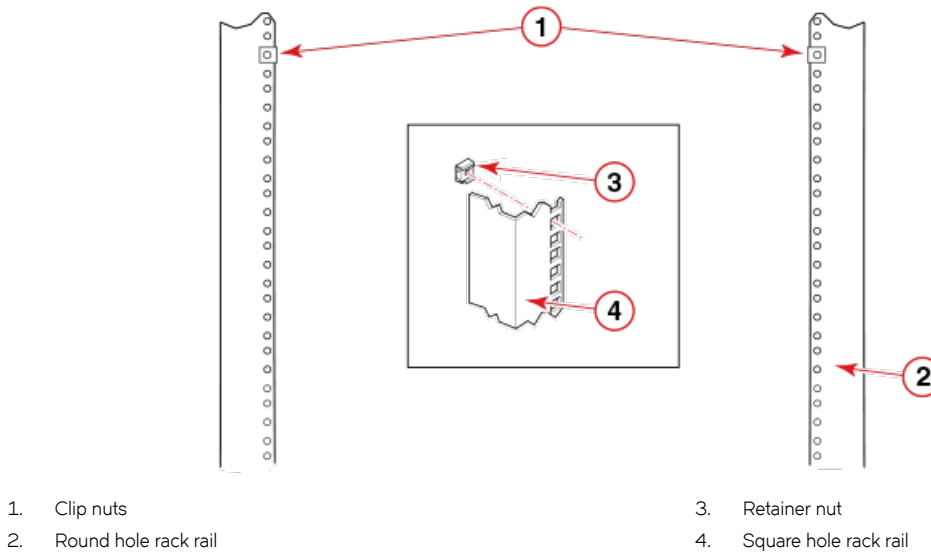

- | | |
|-------------------------|--------------------------|
| 1. Clip nuts | 3. Retainer nut |
| 2. Round hole rack rail | 4. Square hole rack rail |

3. Install the rails on the rack posts, as shown in the following figure.
 - a) Note that the kit contains a rail for the left side of the rack (facing the rack front) and a rail for the right side.
 - b) The rails can be adjusted from 27 to 31 inches (68.58 and 78.74 cm) to accommodate your rack size. To lengthen or shorten a rail, loosen the four 10-32 screws in the two slots on the rail (refer to [Figure 15](#) on page 41) and adjust the shelf to the desired length. Once adjusted, tighten the four 10-32 screws.
 - c) Secure the rails to the rack with eight 10-32 screws with washers, as shown in the following figure.

For rails with round holes, use two 10-32 screws with washers on each end of both rails. Tighten the screws according to the specifications under "Torque requirements" on page 6.

For rails with square holes, use the two standard 10-32 screws with the blue Loctite on the threads and alignment washers on each end of both rails. Tighten the screws according to the specifications under [Torque requirements](#) on page 42.

FIGURE 18 Installing Rails

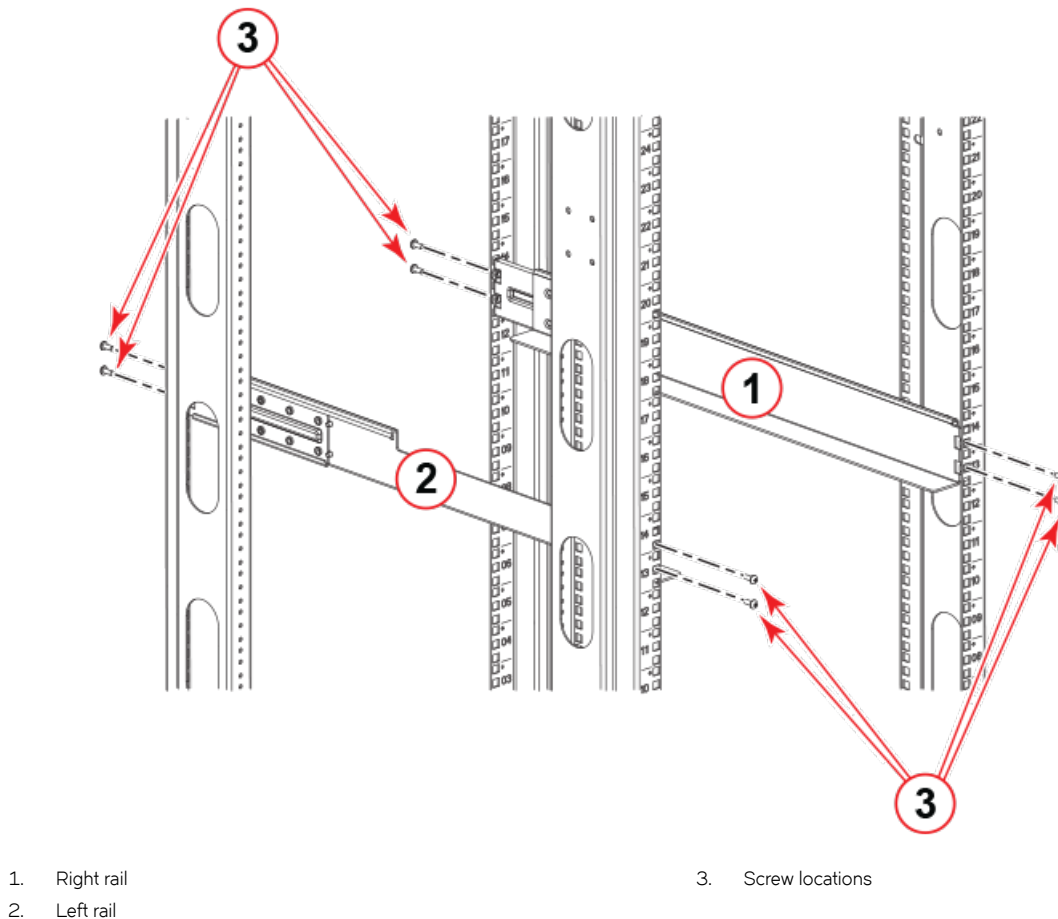

4. Attach the side duct to the left rail by aligning its mounting locations with the slotted holes on the rail. Secure the duct to the rail using the two 6-32 screws (refer to the following figure). Tighten the screws according to the specifications in [Torque requirements](#) on page 42.

FIGURE 19 Attaching the side duct into the left rail (right-front view)

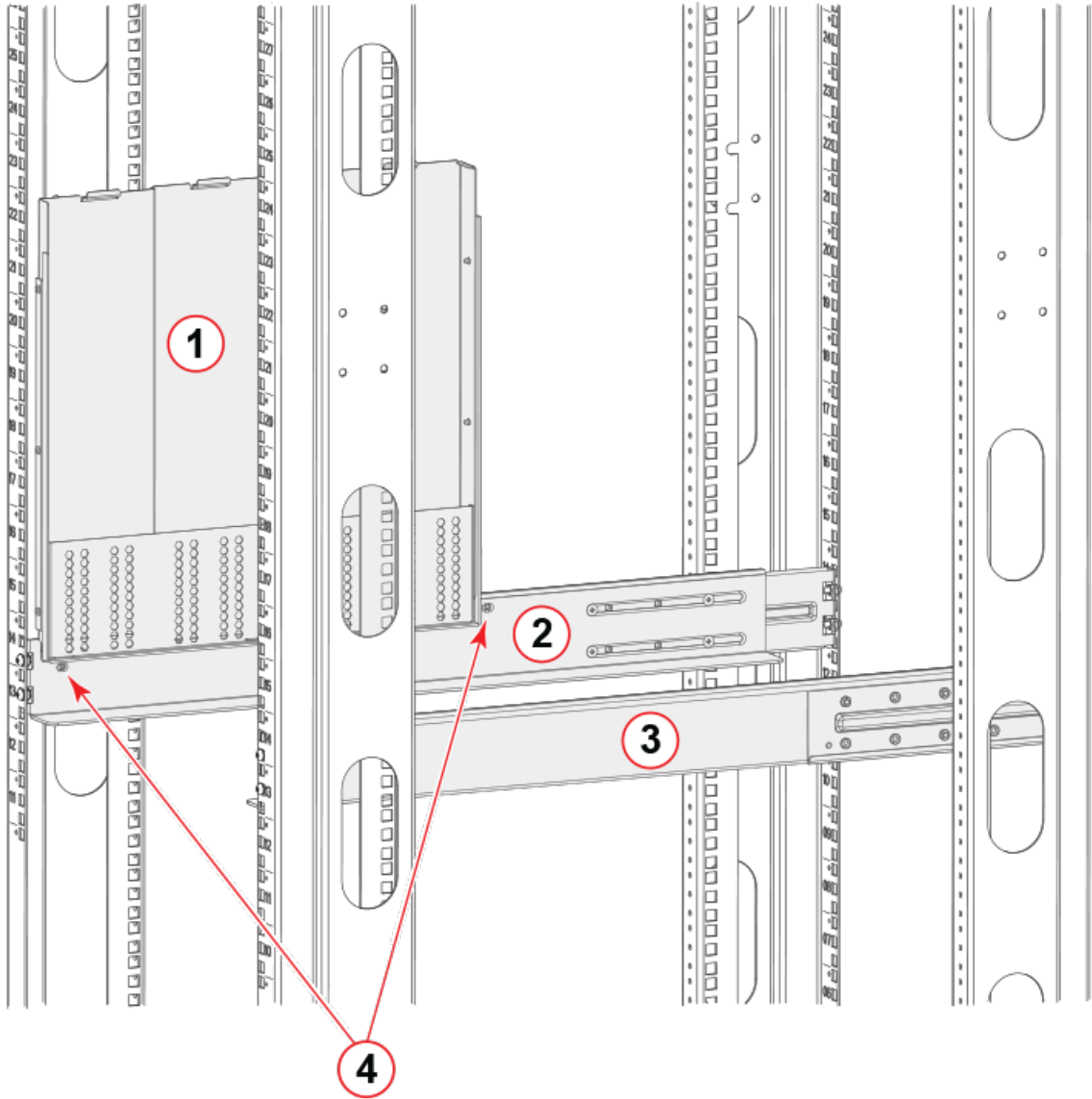

- | | |
|--------------|---|
| 1. Side duct | 3. Right rail |
| 2. Left rail | 4. Side duct screw locations in left rail |

5. Install the top intake assembly into rack.

The top intake assembly can be adjusted to a length between 27 and 31 inches (68.58 to 78.74 cm) to fit in the rack rails. To lengthen or shorten the intake assembly, loosen the 6-32 screws located in the four slots at the rear of the intake assembly, as shown in the following figure. The length will be approximately the length of the adjustable rails.

FIGURE 20 Adjusting length of top intake assembly

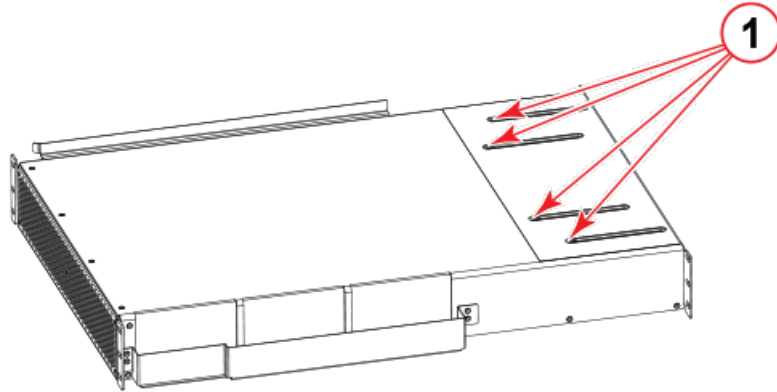

1. Adjustment screw locations on top intake

6. Insert the top intake assembly down onto the side duct and then secure the intake to the rails with eight 10-32 screws with washers, as shown in the following figure. Tighten the screws according to specifications in [Torque requirements](#) on page 42.

NOTE

Be sure to allow for an additional 1U rack space above where you will install the top intake assembly to provide clearance for raising the intake and inserting it on to side duct tabs.

FIGURE 21 Installing top intake assembly into rack

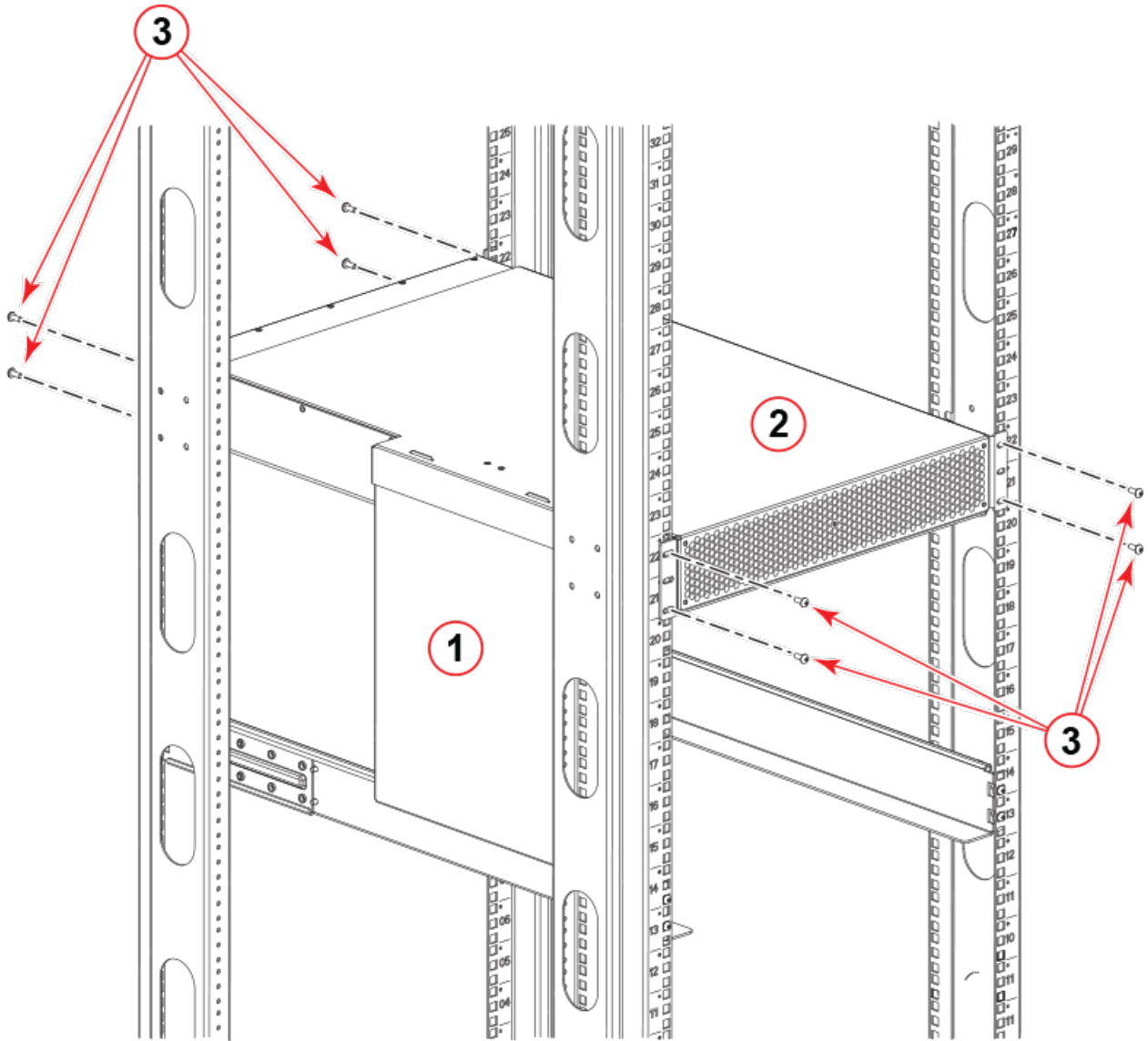

1. Side duct

2. Top intake assembly

3. 10-32 Phillips screw locations

Installing the device in the rack

1. Use a lift to raise the device to the correct level.



DANGER

Use safe lifting practices when moving the product.

2. If applicable, lock the wheels of the lift.
3. Carefully lift the device and slide it into the rack.

- Secure the device to the rack with six 10-32 screws with washers. Refer to the following figure. Tighten the screws according to specifications in [Torque requirements](#) on page 42.

Use the 10-32 x .63 in.(1.60 cm) Phillips screws with square cone washers to secure the device.

Use either 10-32 retainer nut for racks that have rails with square holes or 10-32 clip nut for racks that have rails with round holes to retain screws.

NOTE

Screws, clip nuts, and retainer nuts to secure the device to the rack are provided in the hardware accessory kit that accompanies the device.

FIGURE 22 device with Intake Air Duct Kit installed in the rack

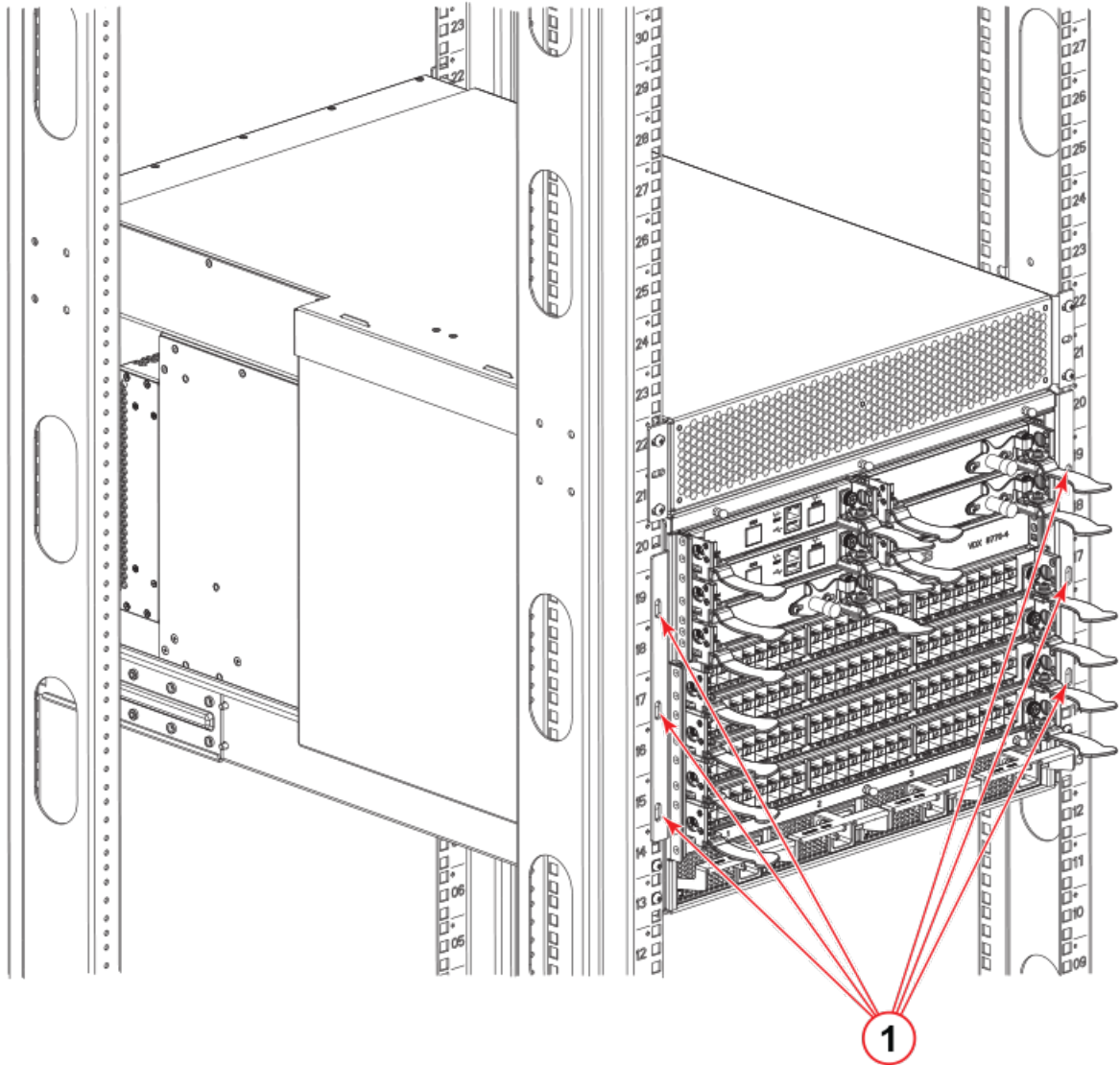

1. Screw locations for mounting device

NOTE

For rails with round holes, use the clip nuts on the rails for securing the 10-32 screws. For rails with square holes, use the retainer nuts. Refer to Figure 1 on page 5 and Figure 2 on page 7.

Installing the air filter

If desired, install the air filter to the air intake grill using the five captive screws, as shown in the following figure.

FIGURE 23 Installation of the air filter

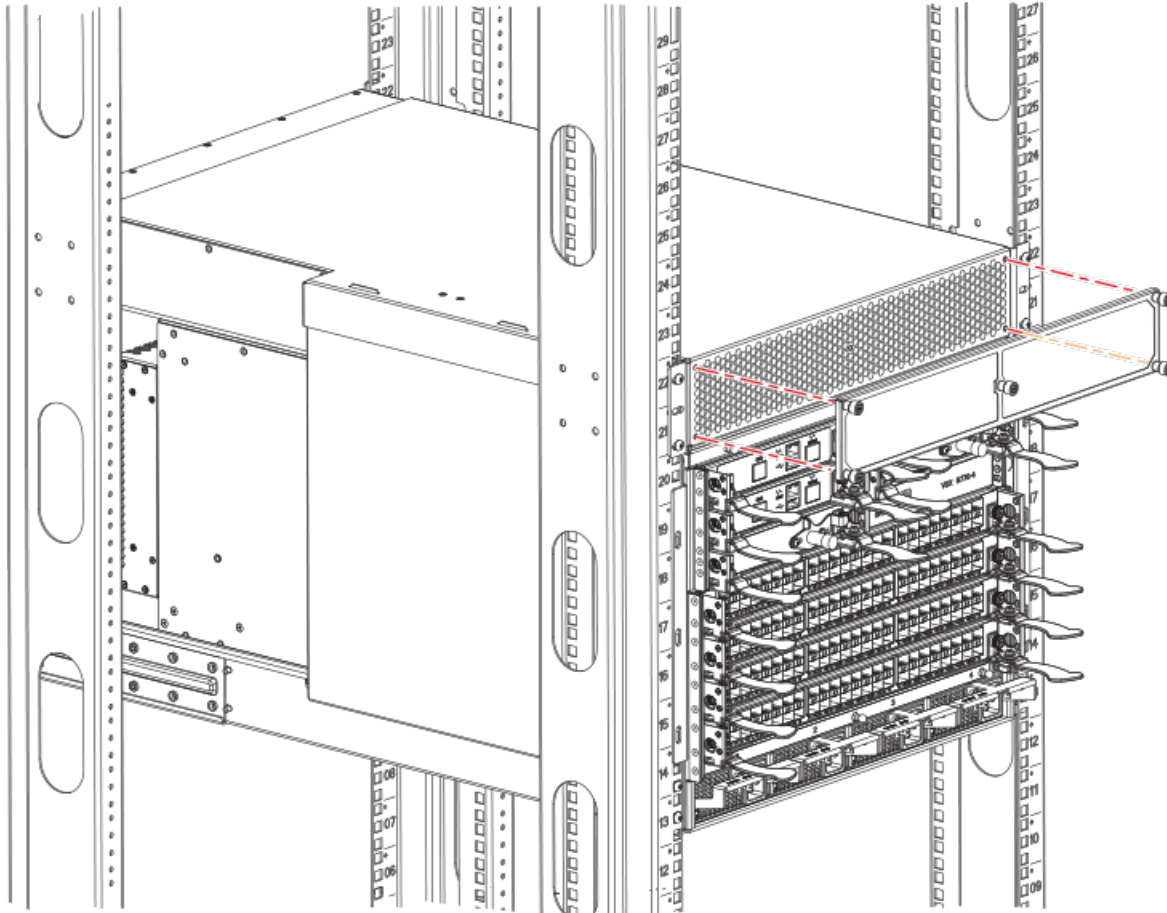

Complete the following steps to mount the new front air filter on the air intake.

1. Orient the new filter over the five mounting holes using the screws as guides.
The mounting is asymmetric, so the holes match up only one way.
Be sure the side marked **BOTTOM** is on the bottom.
2. Using the #2 Phillips screwdriver, initiate the threads, two turns per screw, until all five are started.

3. Tighten all five screws, one at a time.
Do not overtighten the screws as this will compromise the frame, admitting unfiltered air.
The following figure shows the device with the air filter installed.

FIGURE 24 Flush mounted device with the air filter installed

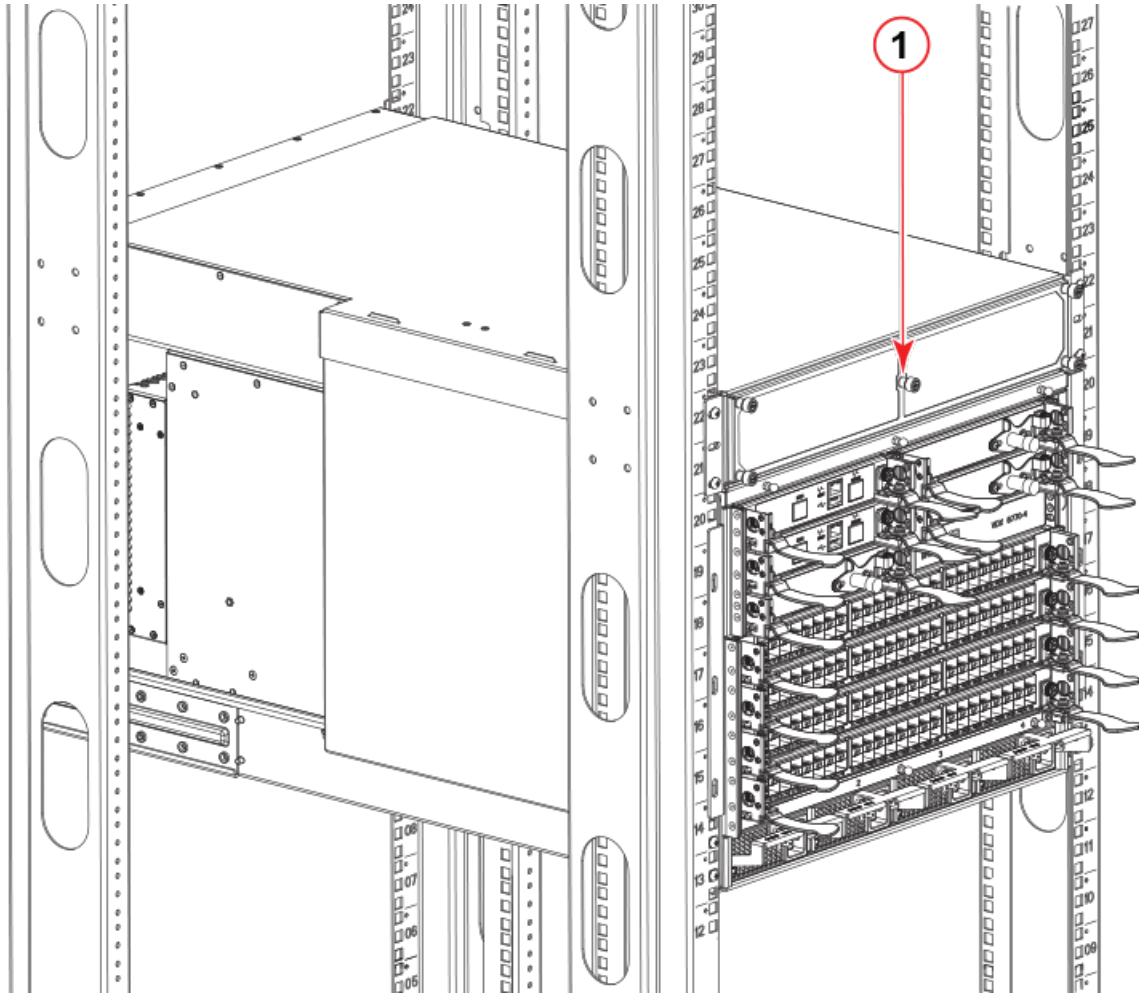

1. Air filter with captive screws

4. Install the cable management system using instructions in the *Hardware Installation Guide* for your device.

Installing the recessed mount Intake Air Duct kit

Use the following procedure to install the recessed mount Intake Air Duct kit.

NOTE

After you unpack the kit, check the contents required for this installation against the parts list in [Figure 16](#) on page 42. This hardware kit is a universal kit, and not all hardware is used for this installation.

Installing the rack hardware

1. Determine how the device can be oriented in the equipment rack so that the port side has access to intake (cool) air.

NOTE

Be sure to allow for an additional 1U rack space above where you will install the top intake assembly to provide clearance for raising the intake and inserting it on to side duct tabs. Refer to [Step 6](#).

2. Install either clip nuts or retainer nuts depending on whether your rack has round holes or square holes. These will allow you to secure the device to the rack posts.

NOTE

For posts with round holes, use the clip nuts on the rack uprights for securing M6 x 1.0 x 12 screws. For posts with square holes, use the retainer nuts. Refer to the following figure.

FIGURE 25 Using clip nuts or retainer nuts to secure screws to the rack posts

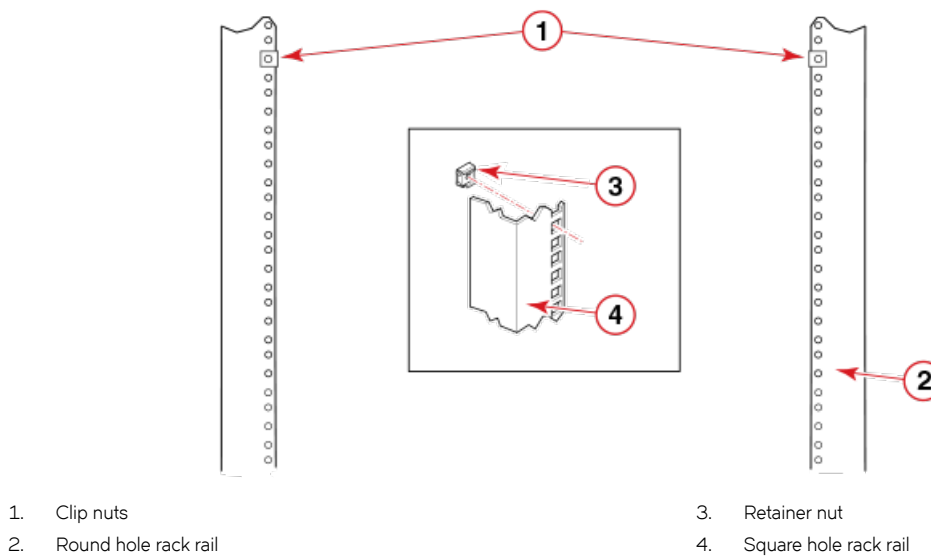

3. Install the rails on the rack posts, as shown in the following figure.
 - a) Note that the kit contains a rail for the left side of the rack (facing the rack) and rail for the right side.
 - b) The rails can be adjusted from 27 to 31 inches (68.58 and 78.74 cm) to accommodate your rack size. To lengthen or shorten a rail, loosen the four 10-32 screws in the two slots on the rail (refer to [Figure 16](#) on page 42) and adjust the shelf to the desired length. Once adjusted, tighten the four 10-32 screws.
 - c) Secure the shelf to the rack with eight 10-32 screws with washers as shown in the following figure.

For rails with round holes, use two 10-32 screws with washers on each end of both rails. Tighten the screws according to the specifications under [Torque requirements](#) on page 42.

For rails with square holes, use the two standard 10-32 screws with the blue Loctite on the threads and alignment washers on each end of both rails. Tighten the screws according to the specifications under [Torque requirements](#) on page 42.

FIGURE 26 Installing rails

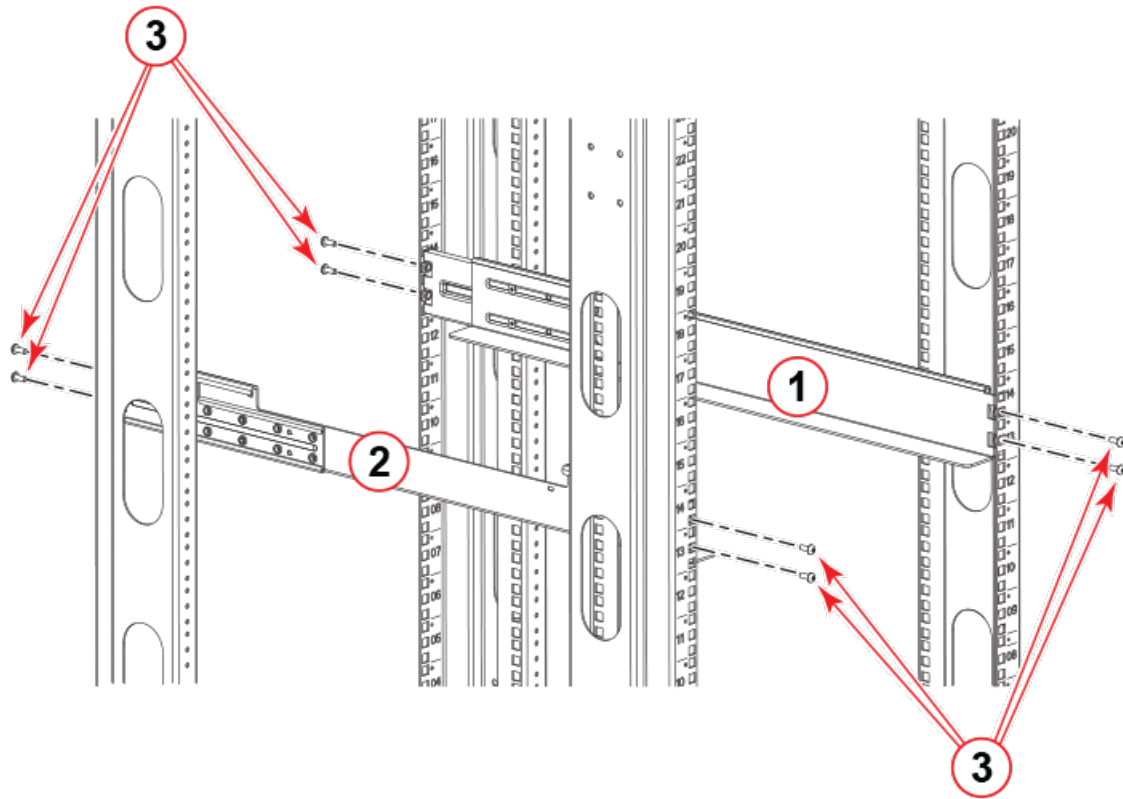

1. Right rail
2. Left rail

3. Screw locations

4. Attach the side duct to the left rail by aligning its mounting locations with the slotted holes on the rail. Secure the duct to the rail using the two 6-32 screws as shown in the following figure. Tighten the screws according to the specifications under [Torque requirements](#) on page 42.

FIGURE 27 Attaching the side duct into the left rail (right-front view)

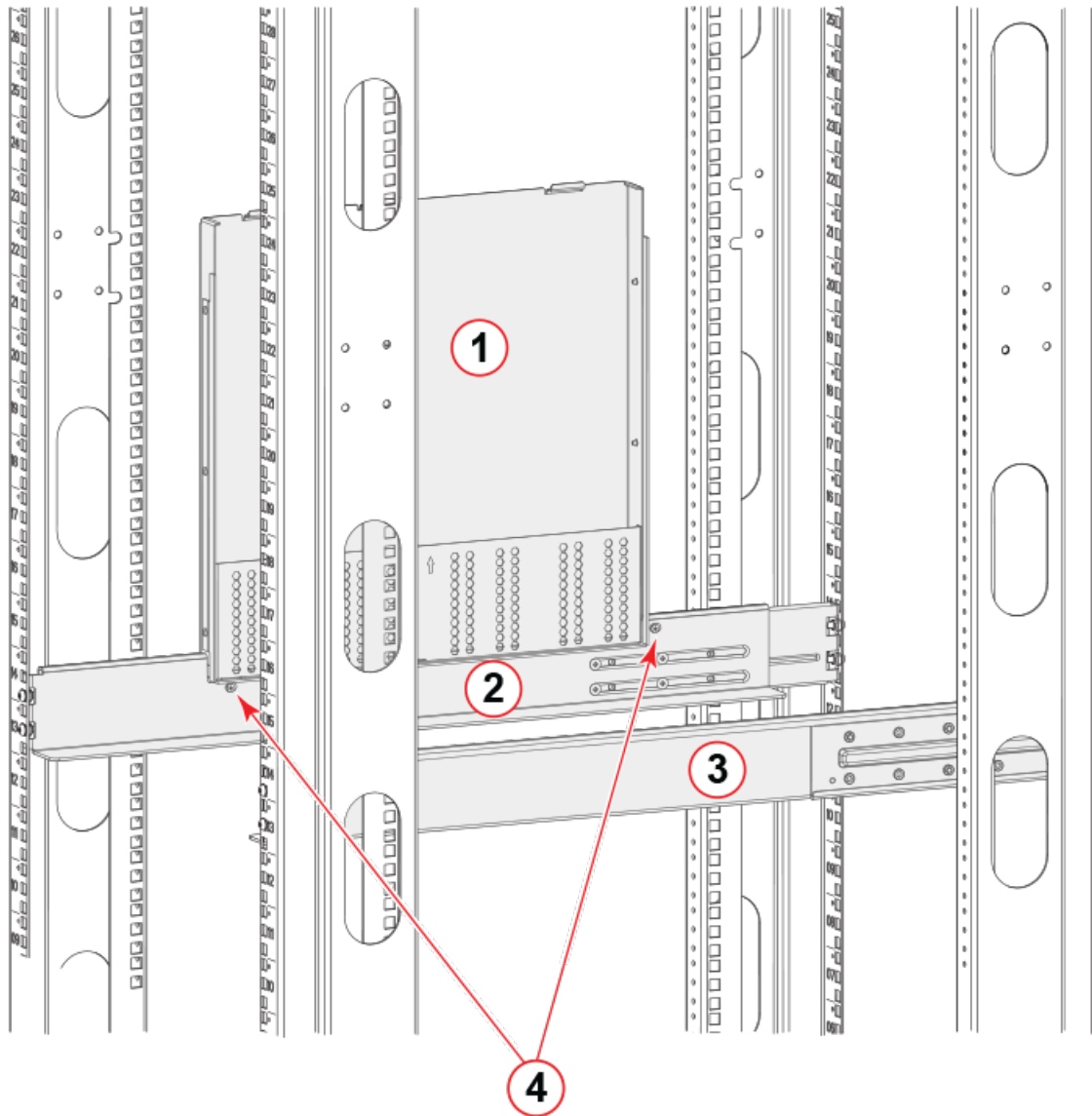

1. Side duct
2. Left rail

3. Right rail
4. Side duct screw locations in left rail

5. Install the top intake assembly into rack.

The top intake assembly can be adjusted to a length between 27 and 31 inches (68.58 to 78.74 cm) to fit in the rack rails. To lengthen or shorten the intake assembly, loosen the 6-32 screws located in the four slots at the rear of the intake assembly as shown in the following figure. The length will be approximately the length of the adjustable rails.

FIGURE 28 Adjusting length of top intake assembly

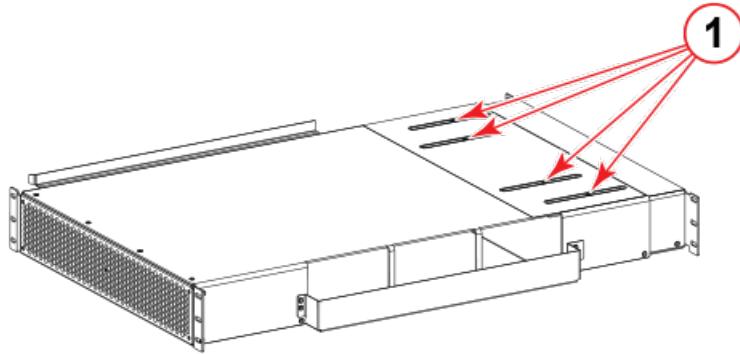

1. Adjustment screw locations on intake

6. Insert the top intake assembly down onto the side duct and then secure the intake to the rails with eight 10-32 screws with washers as shown in the following figure. Tighten the screws according to the specifications under [Torque requirements](#) on page 42.

NOTE

Be sure to allow for an additional 1U rack space above where you will install the top intake assembly to provide clearance for raising the intake and inserting it on to side duct tabs.

FIGURE 29 Installing top intake assembly into rack

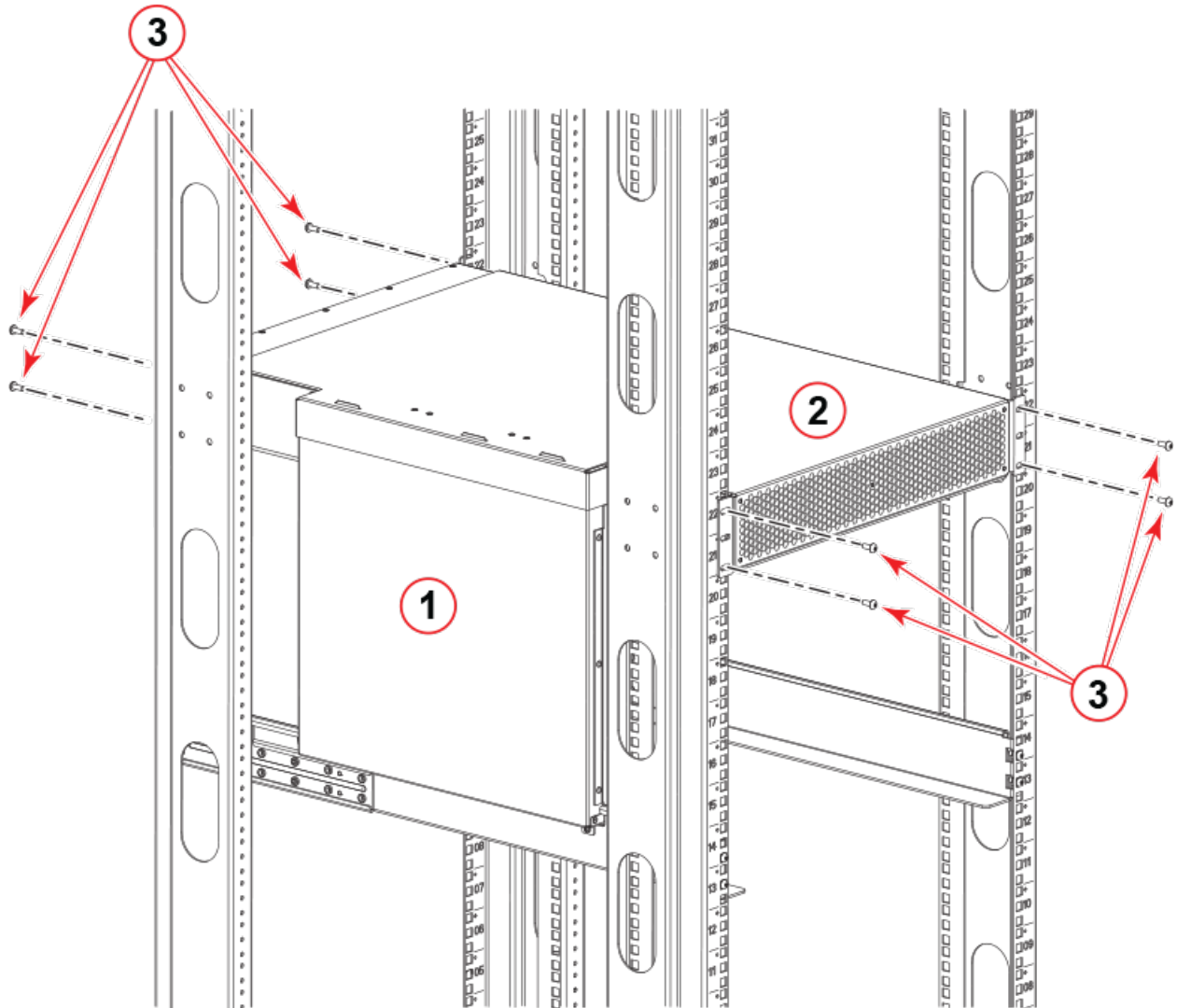

1. 1 Side duct

2. 2 Top intake assembly

3. 3 10-32 Phillips screw locations

Installing the device in the rack

1. Install the recessed rack ears on the device as shown in the following figure.

FIGURE 30 Adding the recessed rack ears

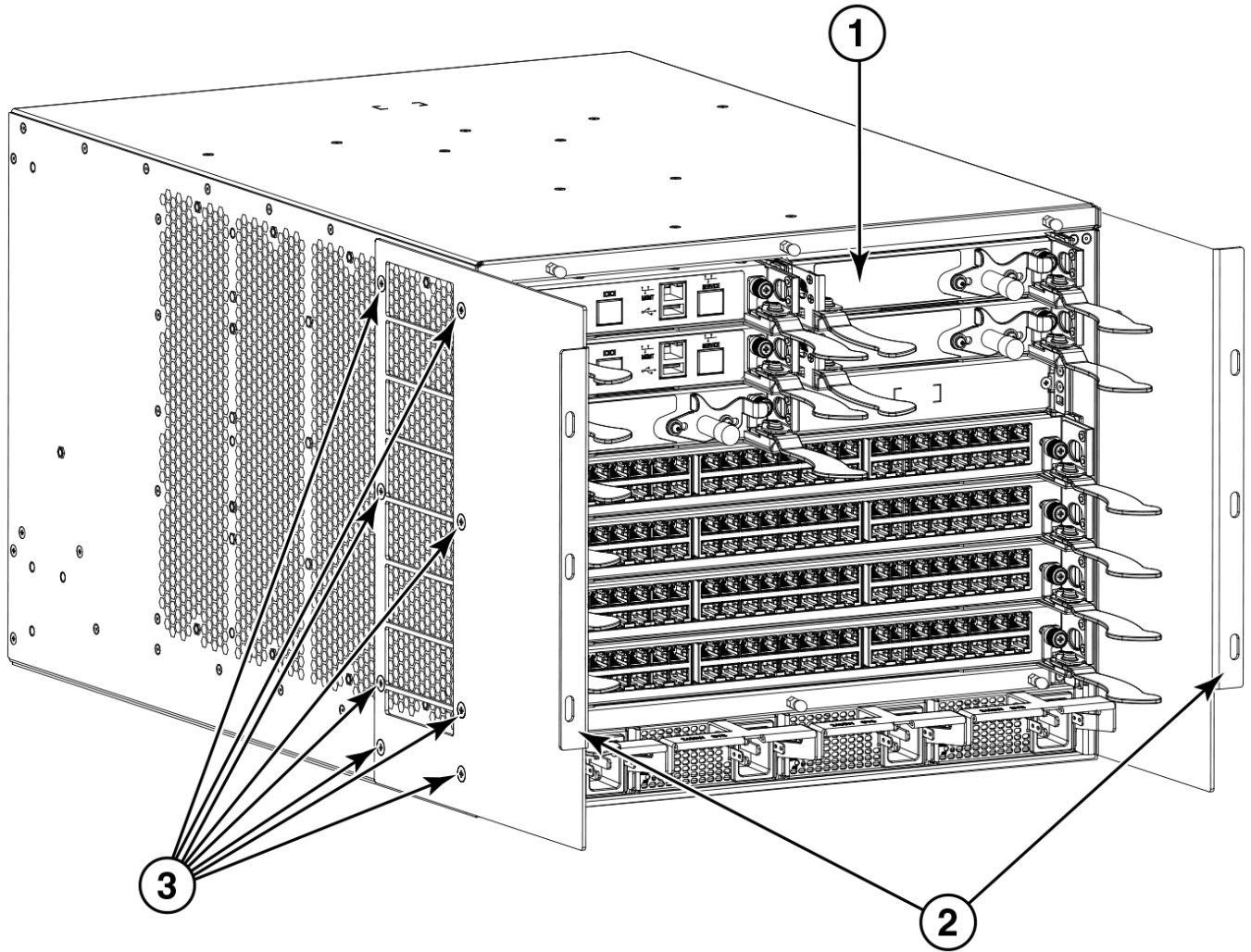

1. device
2. Recessed rack ears
3. Screw locations (opposite side similar)

2. Use a lift to raise the device to the correct level.



DANGER
Use safe lifting practices when moving the product.

3. If applicable, lock the wheels of the lift.
4. Carefully lift the device and slide it into the rack, as shown in the following figure.

- Secure the device to the rack with six 10-32 screws and retainers or clip nuts. Tighten the screws according to the specifications under [Torque requirements](#) on page 42.

Use the 10-32 x .63 in.(1.60 cm) Phillips screws with square cone washers to secure the device. Use either 10-32 retainer nut for racks that have rails with square holes or 10-32 clip nut for racks that have rails with round holes to retain screws.

NOTE

Screws, clip nuts, and retainer nuts to secure the device to the rack are provided in the hardware accessory kit that accompanies the device.

FIGURE 31 Device with Intake Air Duct Kit installed in the rack in a recessed configuration

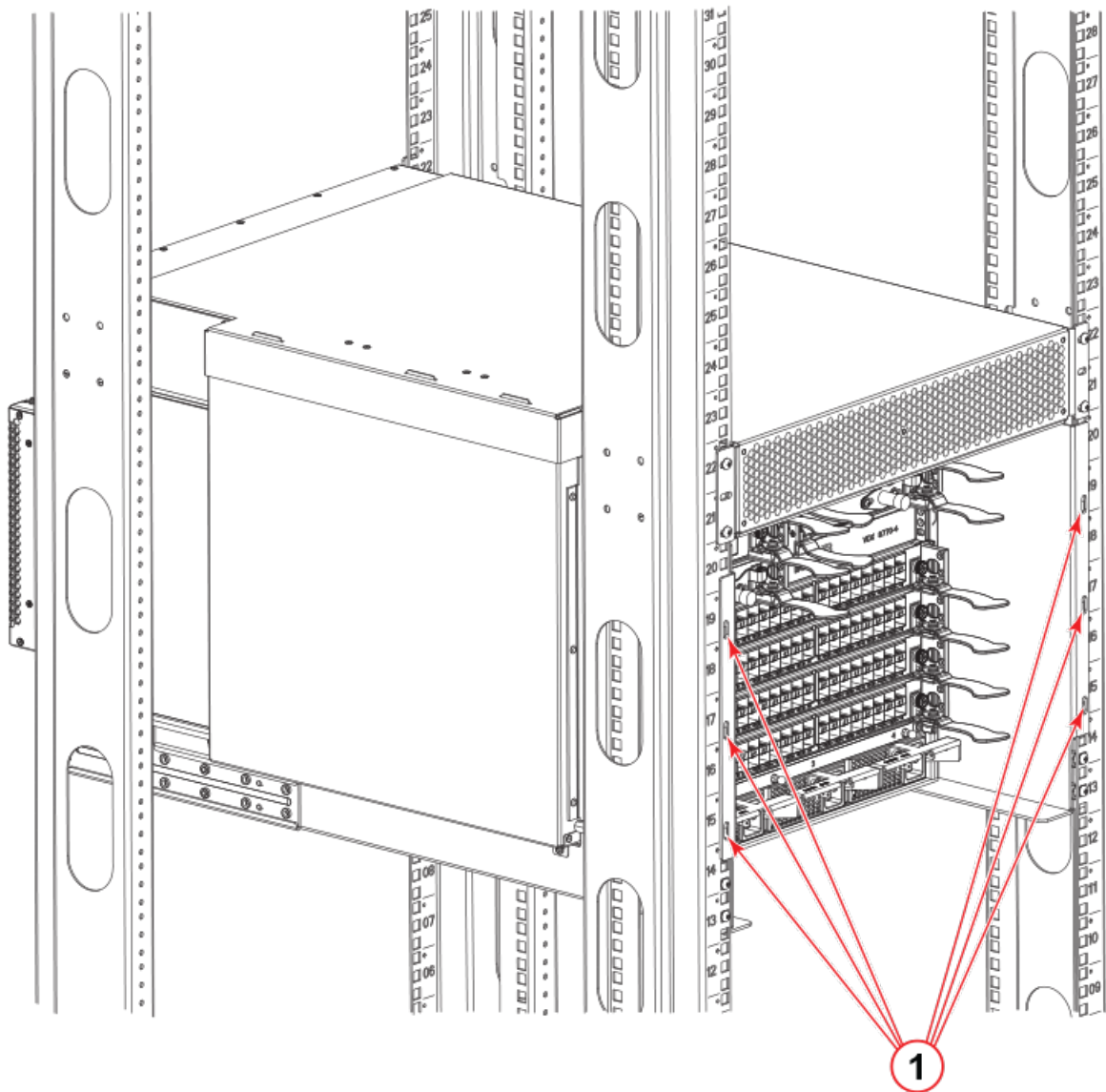

1. Screw locations for mounting device

NOTE

For rails with round holes, use the clip nuts on the rails for securing the 10-32 screws. For rails with square holes, use the retainer nuts. Refer to [Figure 16](#) on page 42 and [Figure 25](#) on page 52.

Installing the air filter

1. Complete the following steps to mount the new front air filter on the air intake.
 - a) Orient the new filter over the five mounting holes using the screws as guides.
The mounting is asymmetric, so the holes match up only one way.
Be sure the side marked **BOTTOM** is on the bottom.
 - b) Using the #2 Phillips screwdriver, initiate the threads, two turns per screw, until all five are started.
 - c) Tighten all five screws, one at a time.
Do not overtighten the screws as this will compromise the frame, admitting unfiltered air.
The following figure shows the device with the air filter installed.

FIGURE 32 Recess mounted device with the air filter installed

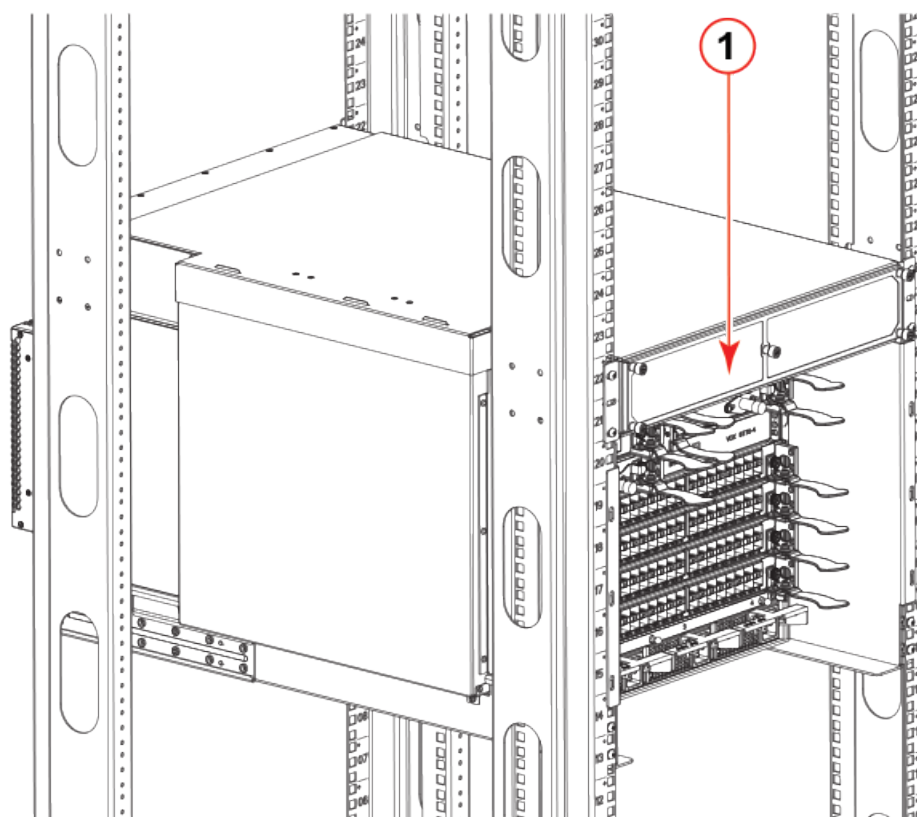

1. Air filter with captive screws

2. Install the cable management system using instructions in the *Hardware Installation Guide* for your device.

Installing the 8U Chassis Flush and Mid-Mount Rack Kit for Two-Post Racks (XBR-RMK-TELCO-4)

Use the following instructions to install the device in either a flush or mid-mount configuration in a two-post telecommunications (Telco) rack using the 8U Chassis Flush and Mid-Mount Rack Kit for Two-Post Racks (XBR-RMK-TELCO-4).

Observe the following when mounting this device:

- Before mounting your device, review any specific installation and facility requirements in this Hardware Installation Guide.
- Hardware devices illustrated in these procedures are only for reference and may not depict the device you are installing into the rack.

Installation requirements

Review the installation and facility requirements for your product before mounting the device. Refer to the hardware installation guide for your product for more information.

Time and items required

Allow approximately one hour to unpack and install the device in a rack.

The following tools are required when installing the rack kit:

- Torque wrench with #2 Phillips screwdriver tip
- Flathead screwdriver
- Hydraulic or assisted lift with a minimum raise of 140 cm (55 in.) and a minimum capacity of 113 kg (250 lbs)

Parts list

The following parts are provided with the 8U Chassis Flush and Mid-Mount Rack Kit for Two-Post Racks (XBR-RMK-TELCO-4).

FIGURE 33 Rack kit parts

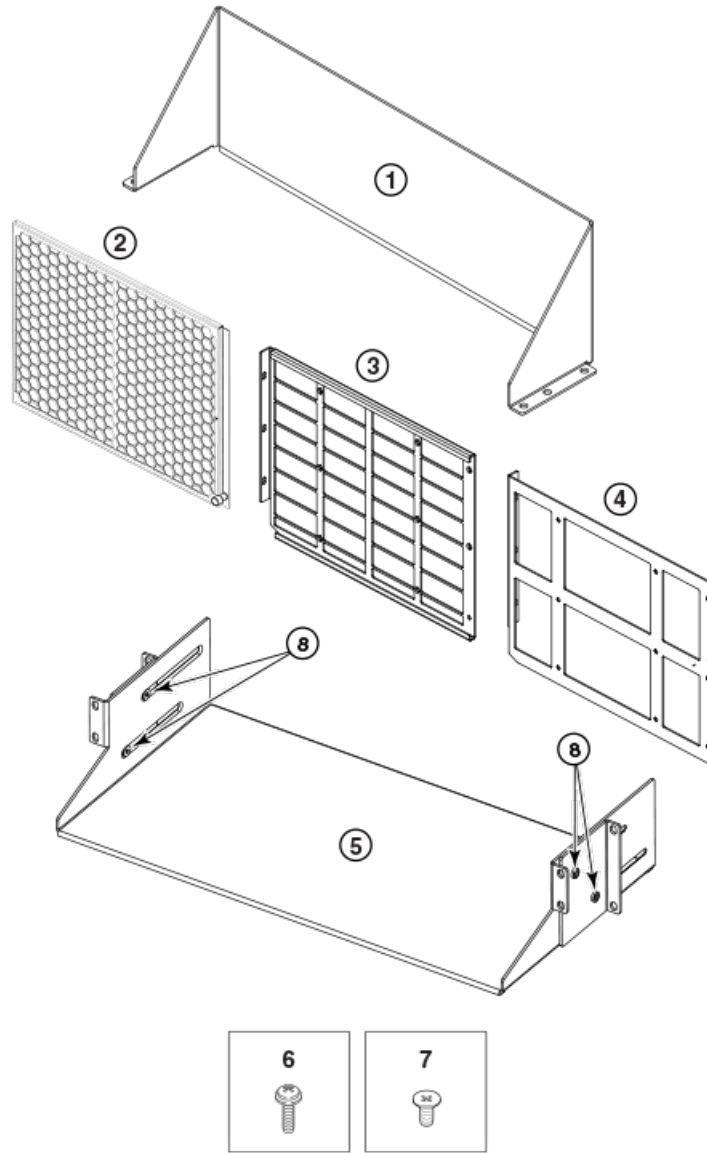

- | | |
|---|--|
| <ul style="list-style-type: none"> 1. Saddle for flush mount 2. Air filter (for mid-mount) 3. Telco mid-mount bracket (left) 4. Telco mid-mount bracket (right) | <ul style="list-style-type: none"> 5. Saddle with sliding brackets for mid-mount 6. 10-32 x .63 in.(1.60 cm) Phillips screws with square cone washer (18) 7. 10-32 x .312 in.(.79 cm) Phillips screws (17) 8. Bracket adjusting screws |
|---|--|

NOTE

Not all parts may be used with certain installations depending on the device type.

Flush-mounting the device in the rack



DANGER

Use safe lifting practices when moving the product.

1. Unpack the rack kit.
2. Align the holes in the saddle with the holes on the mounting posts and attach the saddle using six #10-32 pan head screws that were provided in the kit. The saddle attaches to the rear of the posts. Refer the following figure.

NOTE

Screws are inserted from the rear of the rack.

FIGURE 34 Saddle installed in the rack (screws inserted from the rear of the rack)

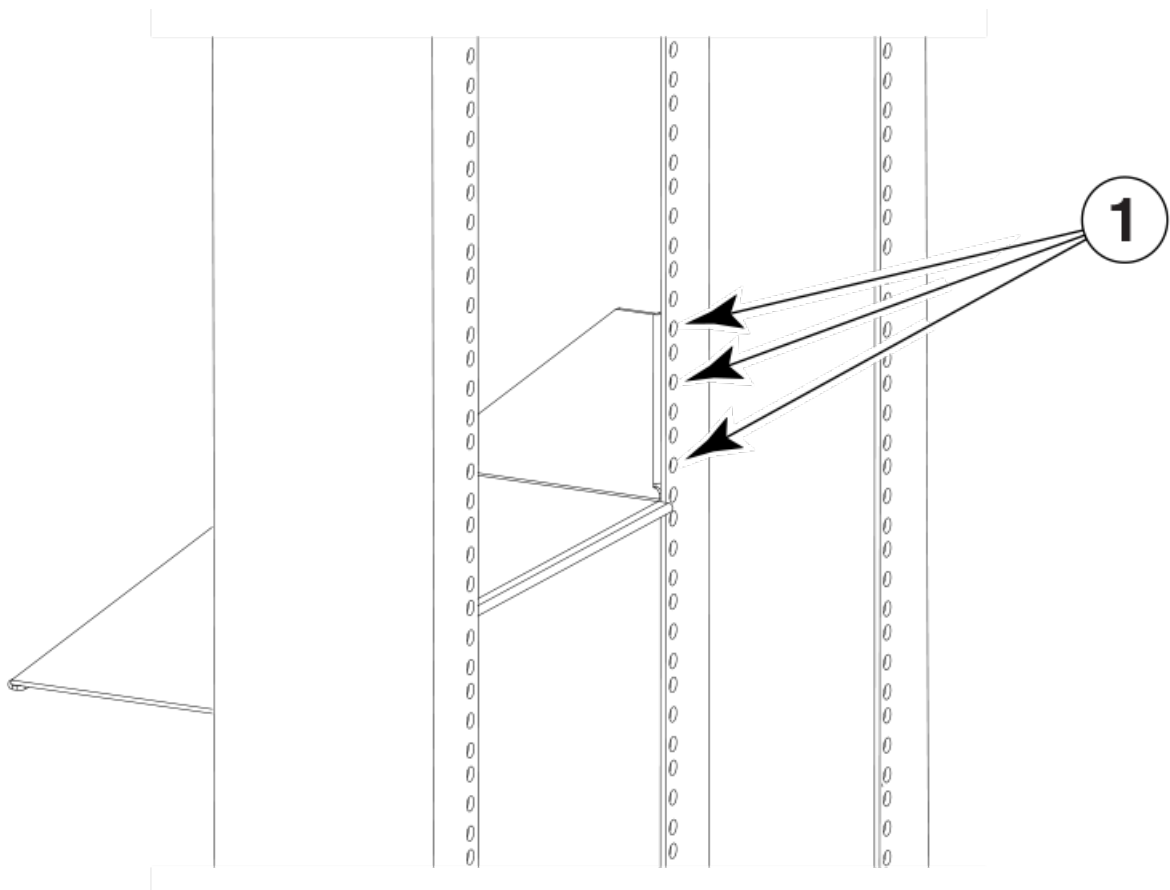

1. Screw locations for mounting saddle (both sides similar) - screw must be inserted from the rear of the rack

3. Maneuver the lift with the switch in front of the saddle and adjust the height to match the saddle.

4. Slide the device onto the saddle and into the rack. Refer the following figure.

FIGURE 35 Device flush installed in a rack

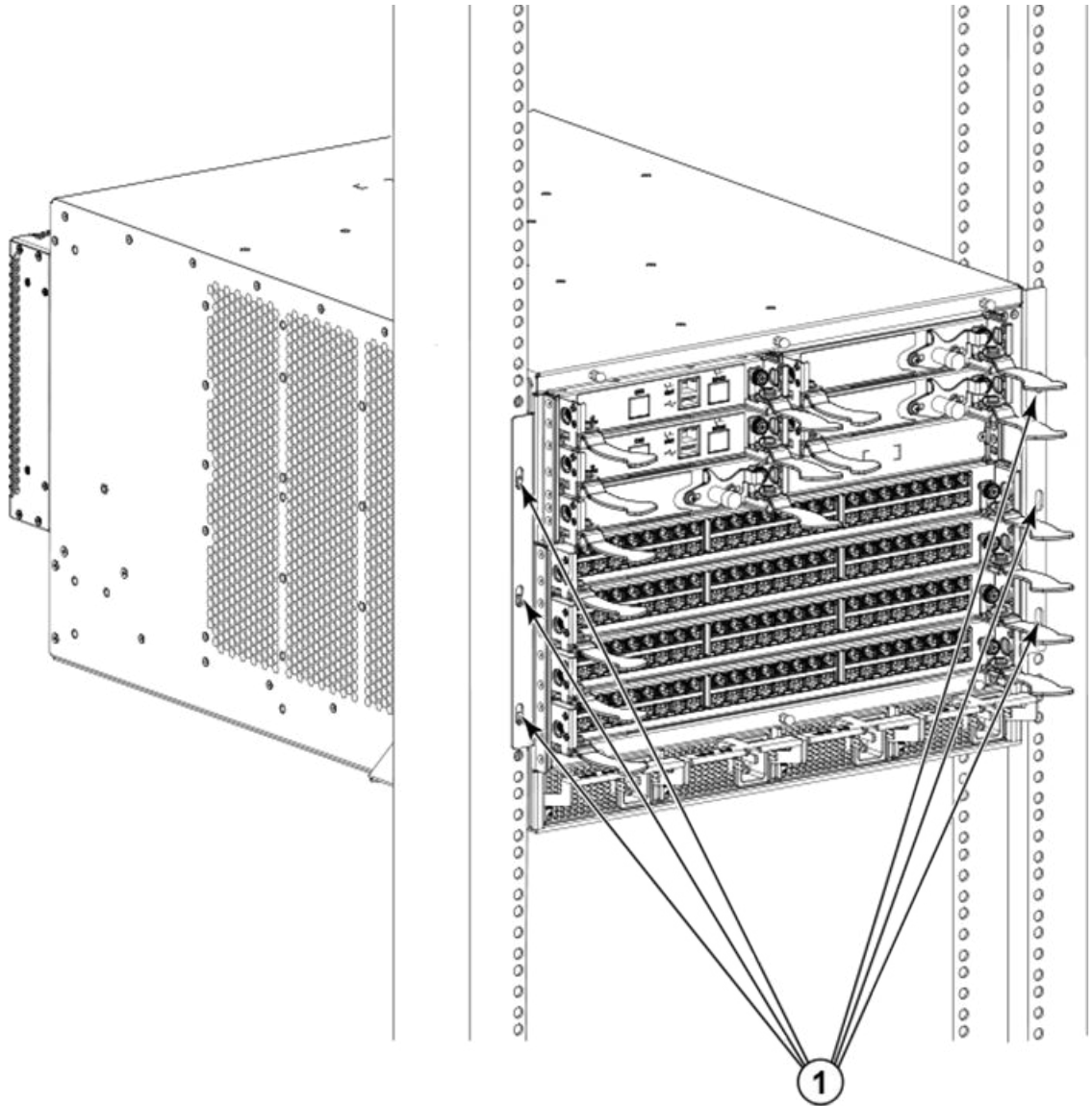

1. Screw locations for mounting device

5. Secure the device to the rack using six 10-32 screws with square-cone washers that were supplied with the device, three screws for each mounting bracket attached to the device. Tighten the screws to 32 in-lb (36.86 cm-kg)

NOTE

Screws, clip nuts, and retainer nuts for mounting the device to the equipment rack are located in the device hardware accessory kit.

Mid-mounting the device in the rack



DANGER

Use safe lifting practices when moving the product.

1. Unpack the rack kit hardware.
2. Loosen the two 10-32 adjusting screws securing the each sliding bracket to the saddle (see [Figure 33](#) on page 61) and slide the brackets as far backward as possible.

3. Install the saddle to the rack posts using the following steps while referring to the following figure. Also refer to [Figure 37](#) for details on securing screws to the rack.
 - a) Install the saddle with the angled portion facing the port side of the rack posts using four 10-32 screws with square-cone washers on each sliding bracket. Tighten the screws to 32 in-lb (36.86 cm-kg).
 - b) Tighten the two 10-32 adjusting screws on each side of the saddle.

FIGURE 36 Saddle installed in equipment rack.

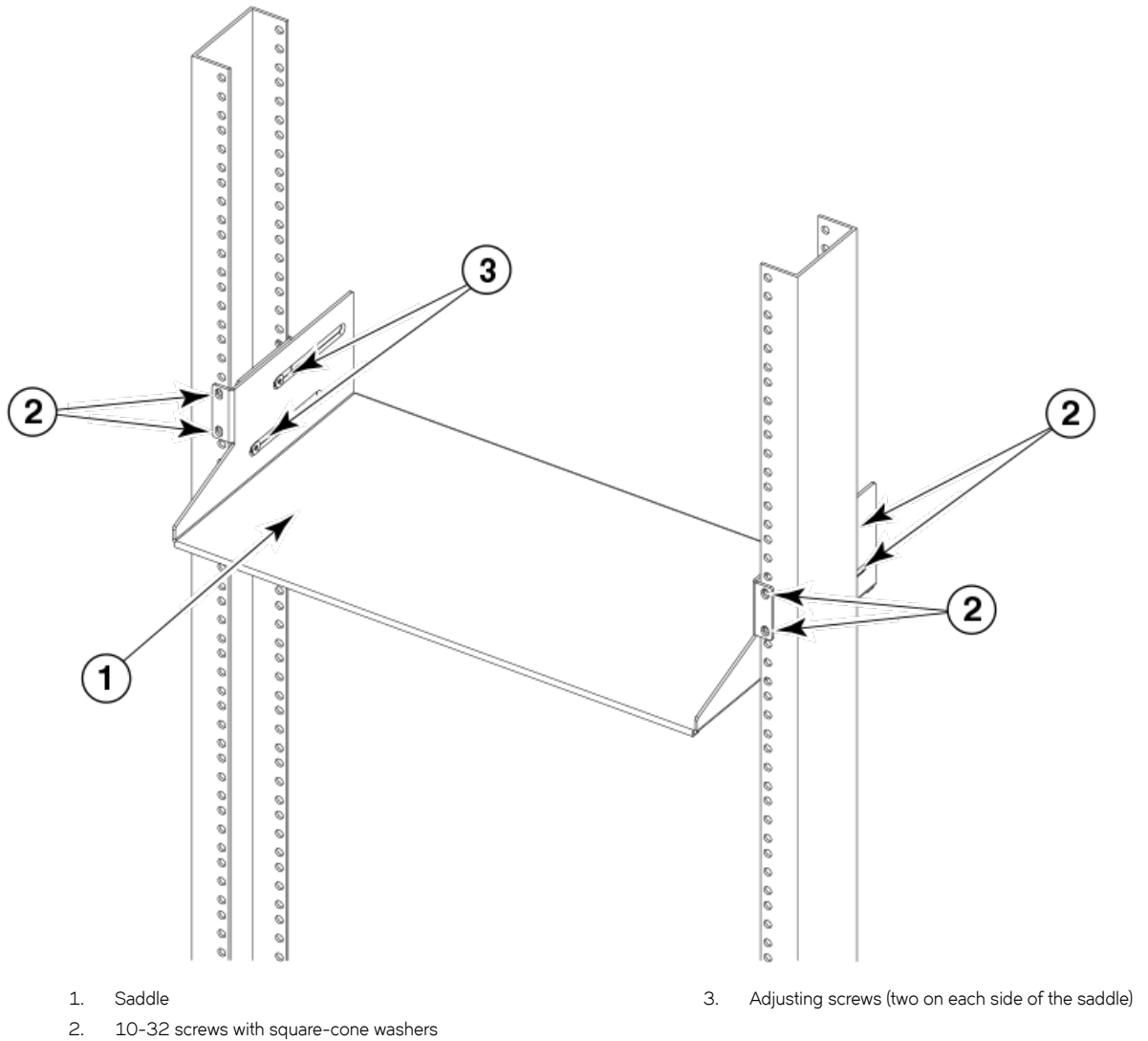

NOTE

For rails with round holes, use the clip nuts (see [Figure 33](#) on page 61) on the rack rails for securing 10-32 screws. For rails with square holes, use the retainer nuts (see [Figure 33](#) on page 61). Also refer the following figure.

FIGURE 37 Using clip nuts and retainer nuts to secure screws to rack rails

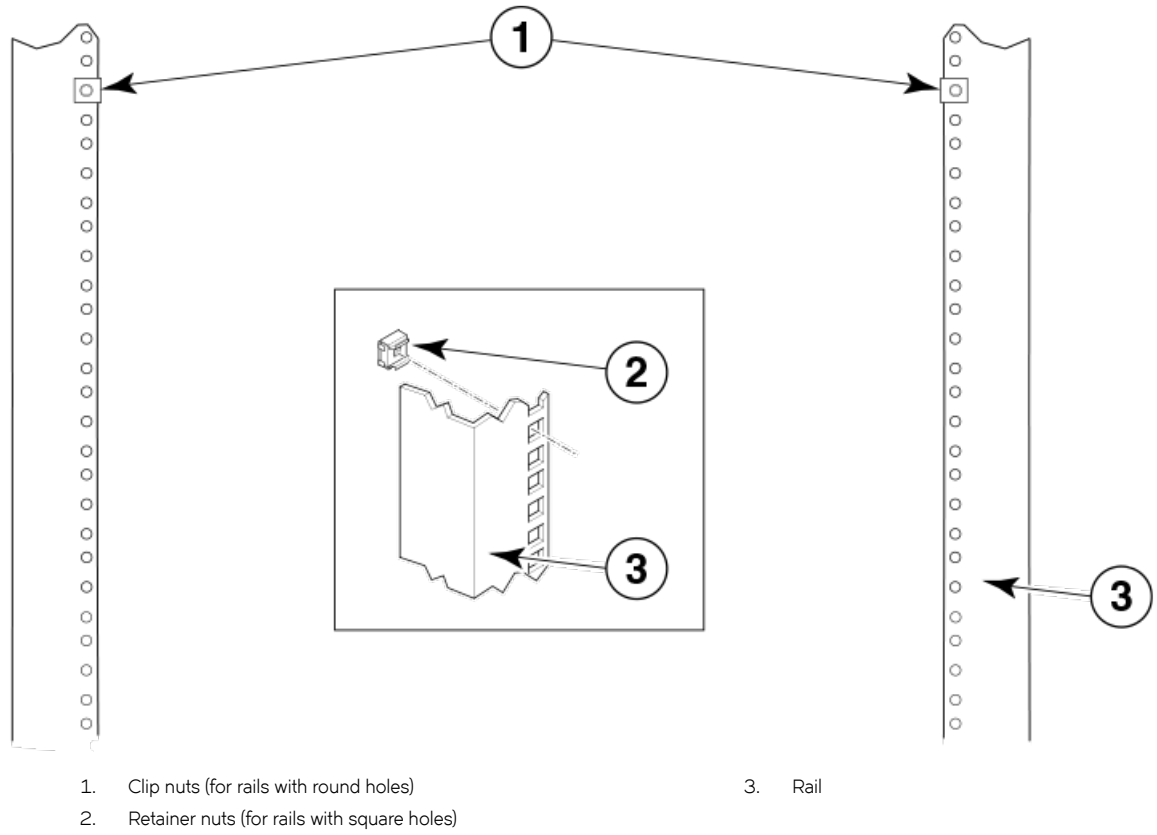

4. Remove any existing rack-mount brackets from the device, and install the new Telco mid-mount brackets from the rack kit. See the following figure.

FIGURE 38 Telco mid-mount brackets installed on the device

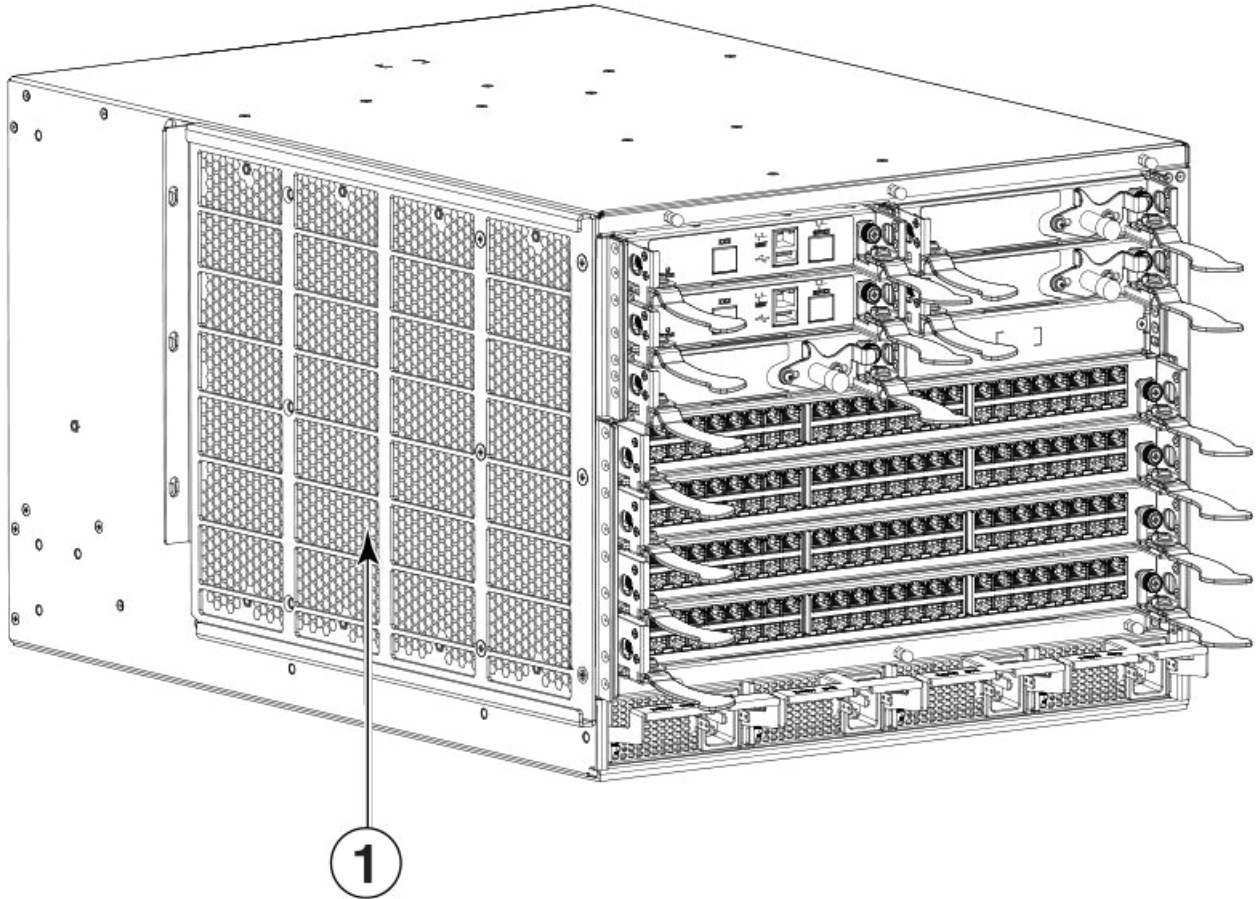

1. Left mid-mount mounting bracket (right bracket similar)

5. Adjust the lift to raise the device to the correct level.
6. If applicable, lock the wheels of the lift.
7. Gently slide the device onto the saddle, ensuring that it remains supported during the transfer.

- Secure the device to the rack using six 10-32 screws with square-cone washers, three screws for each mounting bracket attached to the device. See the following figure. Tighten the screws to 32 in-lb (36.86 cm-kg)

NOTE

Screws, clip nuts, and retainer nuts for mounting the device to the equipment rack are located in the device hardware accessory kit.

FIGURE 39 Device installed in the rack with the mid-mount saddle

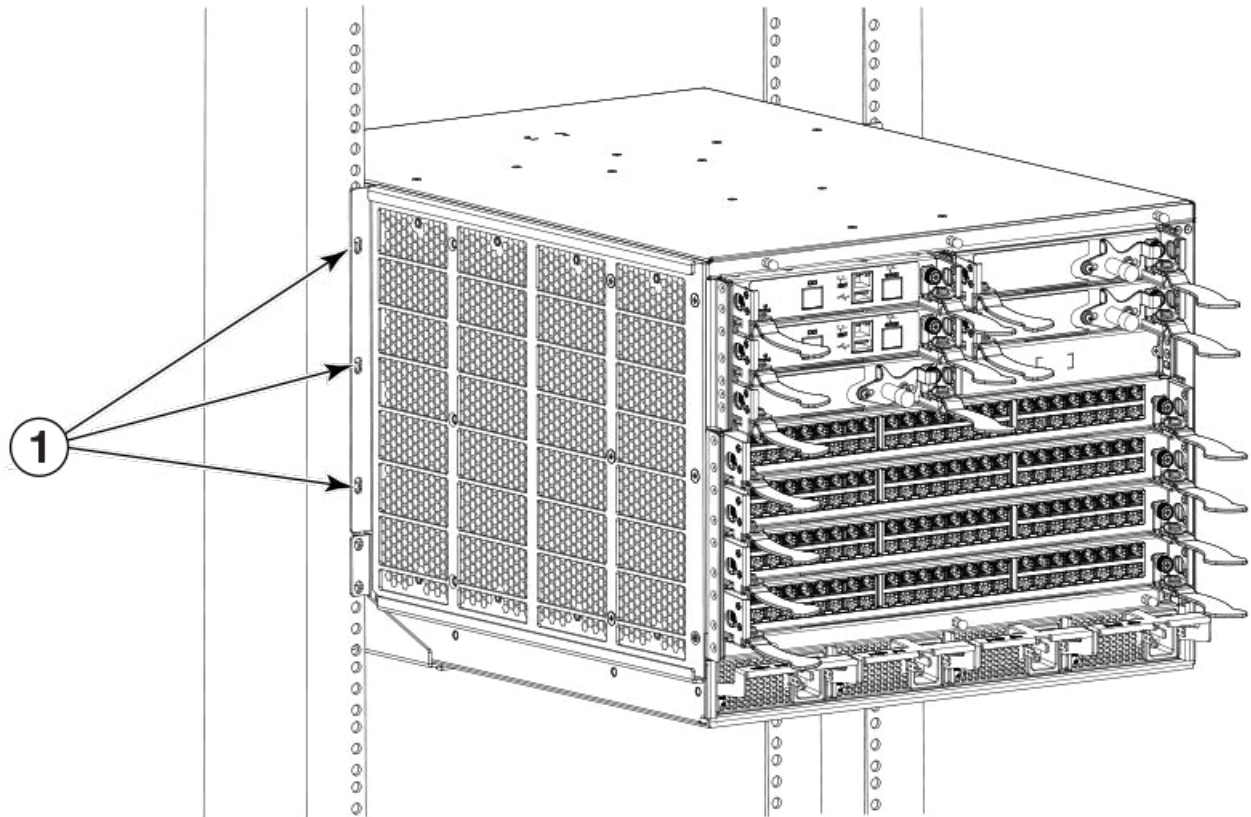

1. Screw locations (opposite side similar)

NOTE

For rails with round holes, use the clip nuts on the rack rails for securing 10-32 screws. For rails with square holes, use the retainer nuts (see [Figure 33](#) on page 61). Also refer to [Figure 37](#).

9. Install the air filter over the left side bracket (as you face the port side). Slide the air filter into the upper and lower guides on the mid-mount bracket and then tighten the captive screw at the lower front of the filter to secure it.

FIGURE 40 Air filter installed on the device

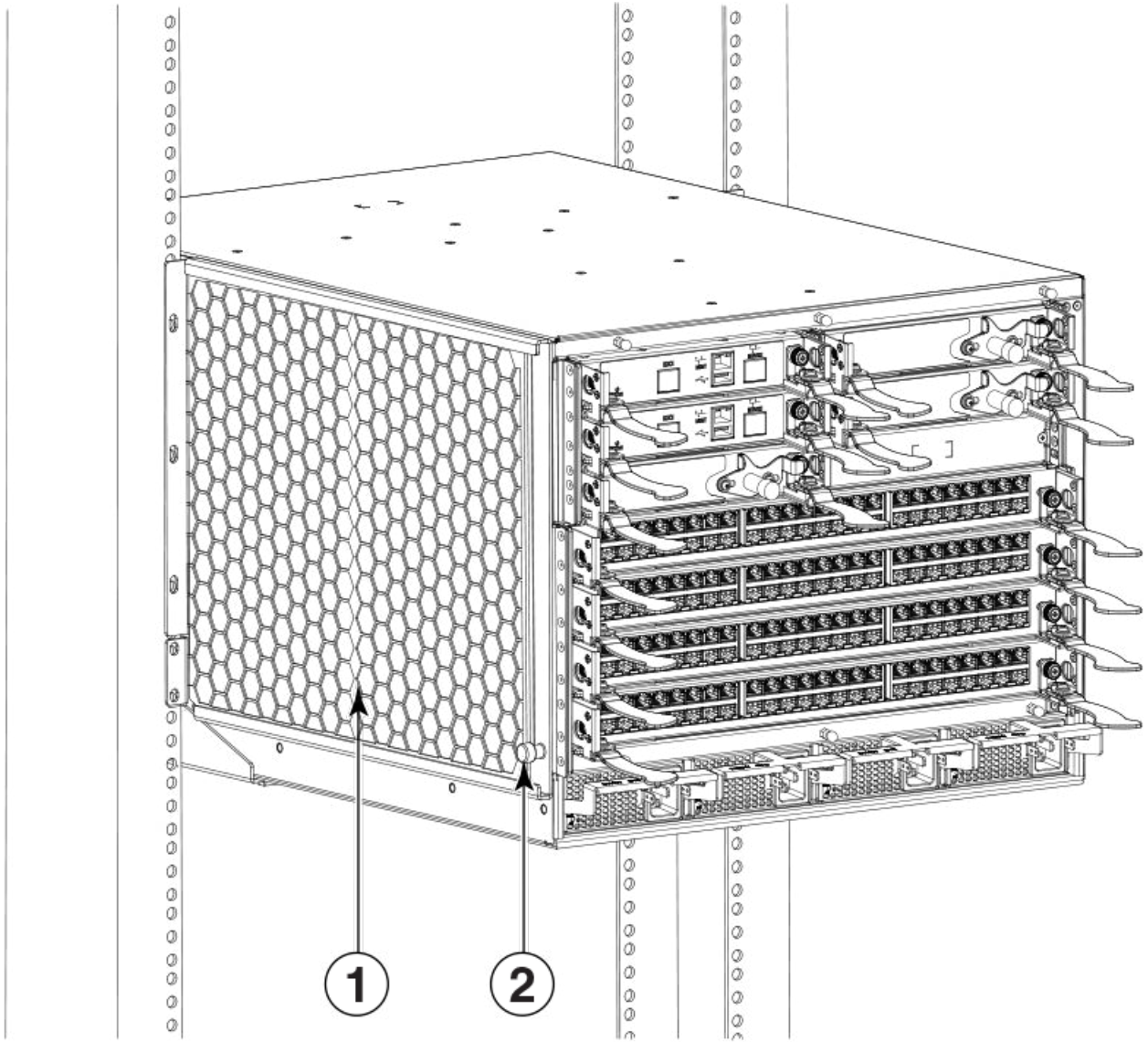

1. Air filter (installed in mid-mount bracket guides)

2. Captive screw

Initial Configuration

• Configuration overview.....	71
• Providing power to the device.....	73
• Establishing a serial connection to the device.....	74
• Logging in to the serial console port.....	75
• Assigning permanent passwords.....	76
• Configuring the IP addresses.....	76
• Logging off the serial console port and disconnecting the serial cable.....	78
• Establishing an Ethernet connection.....	78
• Customizing a host name.....	78
• Customizing a chassis name.....	79
• Setting the date and time.....	79
• Changing the RBridge ID and VCS ID.....	81
• Configuring operating modes on 27x40 GbE line cards.....	82
• Verifying correct operation.....	83
• Backing up a running configuration.....	83
• Connecting network devices.....	84
• Installing transceivers and attaching cables.....	84
• Managing cables.....	86

Configuration overview

- IP address and gateway address for the device
- IP addresses, host names, and gateway addresses for one or two management modules, as needed
- Passwords - You may need to change passwords from their default values and set the time and date, either by the way of NTP or manually.

Upon bootup, the device attempts to form ISLs with connected devices. If the device is not connected to another device, it forms a "single node VCS fabric." This means that the chassis operates as a standalone system, but the operational mode is always VCS-enabled.

In VCS mode, the device can be part of an Ethernet fabric involving two or more VCS-enabled devices. VCS technology embodies the concepts of distributed intelligence and logical chassis. Distributed intelligence means that all configuration and destination information is automatically distributed to each member in the fabric. Distributed intelligence has three major characteristics:

- The fabric is self-forming. When two VCS-enabled devices are connected, the fabric is automatically created and the devices discover the common fabric configuration.
- The fabric is masterless. No single device stores configuration information or controls fabric operations. Any device can fail or be removed without causing disruptive fabric downtime or delayed traffic.
- The fabric is aware of all members, devices, and Virtual Machines (VMs). Automatic Migration of Port Profiles (AMPP) supports VM migration to another physical server. If the VM moves, it is automatically reconnected to all of its original resources.

Logical chassis means that the entire VCS fabric appears and can be managed as a single Layer 2 device. There are three major characteristics to logical chassis:

- Each physical device in the fabric can be managed as if it were a blade in a chassis. When a VCS-enabled device is connected to the fabric, it inherits the configuration of the fabric and the new ports become available immediately.
- You can manage the entire fabric from any device.

- You can manage the edge devices in the fabric as if they were a single device.

In Extreme Network OS v7.1.0 and later, all configuration changes are maintained in the running configuration after a reboot. For prior releases, for nodes in fabric cluster mode only, you must copy the running configuration file to the startup configuration using the **copy running-config startup-config** command to ensure that the device reboots with the preferred configuration.

The device can be deployed as part of a VCS and IP fabrics. For advanced procedures to configure the device for VCS and IP fabrics, refer to the *etwork OS Management Configuration Guide*, *Extreme Network OS IP Fabrics Configuration Guide*, and the *Extreme Network OS Command Reference*.

Configuration tasks

The following figure illustrates the flow of the basic configuration tasks.

FIGURE 41 Configuration tasks

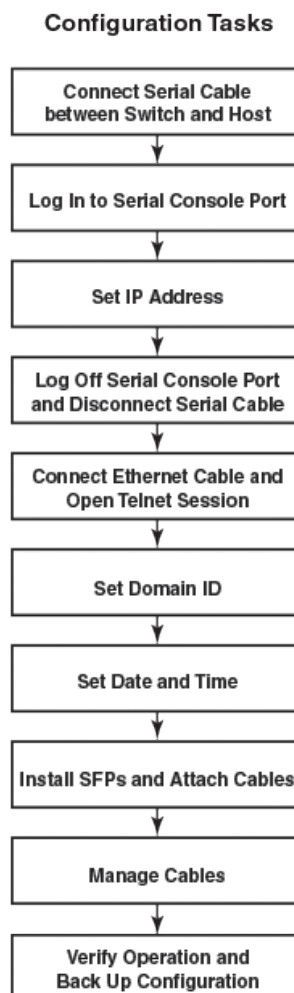

Providing power to the device

Complete the following steps to provide power to the chassis. Each power supply has one power cord.

NOTE

Use the supplied power cords. Ensure the facility power receptacle is the correct type, supplies the required voltage, and is properly grounded.



DANGER

Make sure that the power source circuits are properly grounded, then use the power cord supplied with the device to connect it to the power source.

Connecting an AC power cord

1. Plug the power cord into the power supply.
2. Route the cable so it will be out of the way when connected to the power source.
3. Plug the other end of the cable into the power source.

Connecting a DC power cord

1. Use a #1 Phillips screwdriver to remove the screw that secures the safety cover over the power lugs and remove the safety cover.
2. Use a #2 Phillips screwdriver to unscrew the power lugs.
3. Obtain heat shrink tubing with the following specifications to install on the #2 AWG power supply input wire:
 - Inside diameter: 1.27 cm (.5 in.)
 - Minimum 2:1/50% shrink ratio
 - Nominal Rec. Wall Thickness: 30480 mm (.012 in.) minimum
 - Dielectric strength: 800V/mil
 - Tensile strength: greater than or equal to 5000 psi
 - Operating temperature: -40°C to +150°C (-40°F to 302°F) minimum
 - RoHS compliant
4. Cut off a 5.08 cm (2 in) lengths for each #2 AWG power supply wire.
5. Slide the tubing over the #2 AWG power supply wire.
6. Crimp the #2 AWG power supply wire into the power lug.
7. Slide the tubing over the lug to the brown strip closest to the lug holes.

8. Apply heat to shrink the tubing over the lug and wire insulation.
Installed tubing and lugs on power supply wire should conform to the following illustration.

FIGURE 42 Heat shrink tubing and lug on DC power supply cable

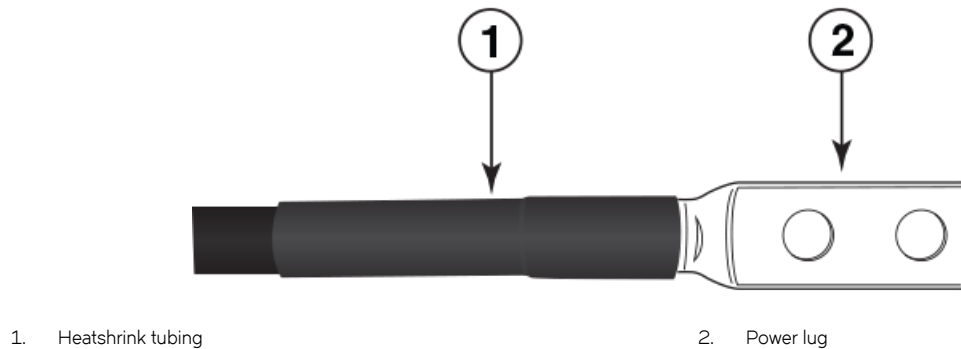

9. Connect the power lugs to the power supply unit.
Connect the -48V wire to the negative terminal and the 0V wire to the positive terminal.

NOTE

The DC return must be isolated from the chassis ground (DC-I) when making connections to the power supply.

10. Replace the safety cover.
11. Plug the other end of the cable into the power source.

NOTE

Do not connect the device to the network until the IP addresses are configured.

For information about LED patterns, see [Connecting a DC power cord](#).

Establishing a serial connection to the device

The serial port is located on the port side of the chassis. The device uses an RJ-45 connector for the serial port. An RJ-45 to DB9 adapter is also provided with the product. The cable supplied with the product is a rollover cable. The serial port is used to connect to a workstation to configure the device IP address before connecting the device to a fabric or IP network.



CAUTION

To protect the serial port from damage, keep the cover on the port when not in use.

To establish a serial connection to the serial (console) port on the device, complete the following steps.

1. Verify that the device is powered on and that POST is complete by verifying that all power LED indicators on the management, switch fabric, and line card modules display a steady green light.
2. Remove the shipping cap from the serial port (labeled **IOIOI**) on the active management module. By default, the management module installed in slot M1 is the active management module unless an error occurs. The active management module is also indicated by an illuminated blue LED labeled **ACTIVE**.

- Use the serial cable provided with the product to connect the serial port on the active management module to a computer workstation.

If the serial port on the workstation or terminal device is DB9 instead of RJ-45, remove the adapter on the end of the serial cable and insert the exposed DB9 connector into the DB9 serial port on the workstation.

NOTE

The serial port is intended primarily for the initial setting of the IP address and for service purposes.

- Disable any serial communication programs running on the workstation (such as synchronization programs).
- Open a terminal emulator application (such as HyperTerminal on a PC, or TERM, TIP, or Kermit in a UNIX environment), and configure the application as follows:
 - In a Windows environment, use the parameters shown in the following table.

TABLE 8 Windows serial connection parameters

Parameter	Value
Bits per second	9600
Data bits	8
Parity	None
Stop bits	1
Flow control	None

NOTE

Flow control is not supported on the serial consoles when attached to remote terminal servers and must be disabled on the customer-side remote terminal server and the host-side clients.

- In a UNIX environment, enter the following string at the prompt:

```
tip /dev/ttyb -9600
```

If ttyb is already in use, use ttya instead and enter the following string at the prompt:

```
tip /dev/ttya -9600
```

Refer to the [ExtremeSwitching VDX 8770 Technical Specifications](#) on page 127 for a listing of serial cable pinouts.

Logging in to the serial console port

Log in to the device through the serial connection with the **admin** user name. The default password is *password*. While you are not required to change the password at the initial login, Extreme Networks recommends that you change your admin and user passwords. Refer to [Assigning permanent passwords](#) on page 76 for more details. Make sure to write down the new passwords and keep this information in a secure location.

```
Network OS (8770HOST)
8770HOST console login: admin
Password:
WARNING: The default password of 'admin' and 'user' accounts have not been changed.
Welcome to the Extreme Network Operating System Software
admin connected from 127.0.0.1 using console on 8770HOST
8770HOST#
```

Assigning permanent passwords

The factory-configured default accounts on the device are "admin," "user," and "root". Use the default administrative account as shown in the following table to log in to the device for the first time and to perform the basic configuration tasks.

The root account, disabled by default, is reserved for development and manufacturing. The user account is read-only and intended primarily for system monitoring.

TABLE 9 Default administrative account names and passwords

Account type	Login name	Password
Administrative	admin	password
User account (read-only)	user	password

Changing the default account passwords

When you change the default account password after you log in for the first time, only the default password rule is in effect. The rule specifies a minimum password length of eight characters. For advanced user and role management, including setting password rules, refer to the Security chapter of the *Extreme Network OS Security Configuration Guide*.

NOTE

Passwords can be 8 to 40 characters long. They must begin with an alphabetic character. They can include numeric characters, the period (.), and the underscore (_) only. Passwords are case-sensitive, and they are not displayed when you enter them on the command line. The available roles are "admin" and "user". For more information on passwords, refer to the *Extreme Network OS Security Configuration Guide*.

1. Log on to the device using the admin account (the default password is *password*).
2. Enter **configure terminal** to change to global configuration mode.

```
device# configure terminal
Entering configuration mode terminal
```

3. Enter the **configure terminal** command to enter global configuration mode.
4. Enter the **username** command followed by the account name and the password parameter.
5. When prompted, enter the new password. and press **Enter** .

Following is an example of using these commands:

```
device# configure terminal
Entering configuration mode terminal
device(config)# username admin password [new-password]
(<WORD>;User password satisfying password-attributes):*****
```

Configuring the IP addresses

You must configure the device with a static IP address in IPv4 or IPv6 format . DHCP is not supported.

Setting a static IP address

Complete the following steps to set a static IP address.

1. Log in to the device using an account that has the admin role.
2. Enter global configuration mode using the **configure terminal** command.
3. Specify the chassis with the **rbridge-id** command.

```
device(config)# rbridge-id 1
```

4. Use the **chassis virtual-ip** command to set the IP address for the chassis.

```
device(config-rbridge-id 1)# chassis virtual-ip 10.20.236.132/20
```

5. Return to configuration mode by entering **exit**.
6. Use the **ip address** command to set the Ethernet IP address for the management modules.

If you are going to use an IPv4 IP address, enter the IP address in dotted decimal notation. You should also enter a gateway address as well.

When you have assigned the IP and gateway addresses to management interface 1/1, you should also assign IP and gateway addresses to management interface 1/2 if you have installed a second management module.

```
device(config)# interface Management 1/1
device(config-Management-1/1)# no ip address dhcp
device(config-Management-1/1)# ip address 10.24.85.81/20
device(config-Management-1/1)# ip gateway-address 10.24.80.1
```

NOTE

The **ip gateway-address** command will not be available on the device if the Layer 3 or Advanced Services license is installed. In that case, use the following command sequence

```
switch(config)# rbridge-id 1
switch(config-rbridge-id 1)# ip route 0.0.0.0/0 <default-gateway>
```

If you are going to use an IPv6 address, enter the network information in semicolon-separated notation as prompted after the **ipv6 address** operand. You should also disable DHCP.

```
device(config)# interface Management 1/1
device(config-Management-1/1)# no ip address dhcp
device(config-Management-1/1)# ipv6 address \
fd00:60:69bc:832:e61f:13ff:fe67:4b94/64
```

7. Return to privileged EXEC mode by entering **exit**.

```
device(config)# exit
device#
```

8. To display the configuration, use the **show running-config interface Management** command.

```
device# show running-config interface Management 1/1
interface Management 1/1
no ip address dhcp
ip address 10.24.85.81/20
ip gateway-address 10.24.80.1
ipv6 address fd00:60:69bc:832:e61f:13ff:fe67:4b94/64
no ipv6 address autoconfig
!
```

Logging off the serial console port and disconnecting the serial cable

You can use the serial port to monitor error messages through the serial connection. If the serial port is no longer required, use the **logout** command to log out of the serial console, remove the serial cable, and replace the protective plug in the serial port.

NOTE

To protect the port from damage, keep the cover on the port when not in use.

Establishing an Ethernet connection

After using a serial connection to configure the IP addresses for the device, you can connect the active management module to the local area network (LAN).

NOTE

Connecting the management modules to a private network is recommended.

By establishing an Ethernet connection, you can complete the device configuration using a serial session, Telnet, or management application, such as Extreme Network Advisor.

NOTE

To protect the port from damage, keep the cover on the port when not in use.

Perform the following steps to establish an Ethernet connection.

1. Remove the shipping plug from the Ethernet port on the active management module.
2. Insert one end of an Ethernet cable into the Ethernet port.
3. Connect the other end to an Ethernet 10/100/1000 Base-T LAN.

You can access the device through a remote connection using the command line by way of Telnet or any of the management tools available.

4. To complete any additional configuration procedures through a Telnet session, log in to the device by Telnet using the **admin** login. The default password is *password*.

Customizing a host name

This procedure is optional.

While still in Telnet, you can change the host name of the device. The host name can be up to 30 characters long; it can include letters, numbers, hyphens, and underscore characters; and must begin with a letter. The default host name is "sw0." The host name is displayed at the system prompt.

1. Log in to the device using an account that has the admin role.
2. Enter **configure terminal** to change to global configuration mode.

```
device# configure terminal
Entering configuration mode terminal
```

3. Enter **switch-attributes** followed by the RBridge ID and the **host-name** operand with the new name.

If you have changed the RBridge ID, be sure to use that ID.

```
device(config)# switch-attributes 1 host-name <host-name>
```

4. Record the new name for reference.
5. Enter **exit** while in global configuration mode to return to privileged EXEC mode.

```
device(config)# exit
device#
```

6. To verify the new host name, you can run the **show running-config** command in EXEC mode.

```
device# show running-config
```

Customizing a chassis name

This procedure is optional.

While still in Telnet, you can change the chassis name. The chassis name can be up to 30 characters long; can include letters, numbers, hyphens, and underscore characters; and must begin with a letter. The default chassis name is "VDX8770-#" where # is the number of ports.

Extreme Networks recommends that you customize the chassis name for each platform because some of the system logs refer to the platform by its chassis name.

1. Log in to the device using an account that has the admin role.
2. Enter global configuration mode using the **configure terminal** command.
3. Enter **switch-attributes** followed by the RBridge ID and the **chassis-name** operand with the new chassis name.

If you have changed the RBridge ID, be sure to use that ID.

```
device(config)# switch-attributes 1 chassis-name B8770_prime
```

4. Record the new name for reference.
5. Enter **exit** while in global configuration mode to return to privileged EXEC mode.

```
device(config)# exit
device#
```

6. To verify the new chassis name, you can run the **show running-config switch-attributes rbridge-id** command.

```
device#
show running-config switch-attributes 1
```

Setting the date and time

The management module maintains the current date and time inside a battery-backed real-time clock (RTC) circuit. Date and time are used for logging events. The operation of the device does not depend on the date and time; an Extreme Networks device with an incorrect date and time value functions properly. Because the date and time are used for logging, error detection, and troubleshooting, you should set them correctly.

Time zones

You can set the time zone for a device by using the **clock timezone** command. The time zone setting has the following characteristics:

- The time zone setting automatically adjusts for Daylight Savings Time.
- Changing the time zone on a device updates the local time zone setup and is reflected in local time calculations.
- By default, all devices are in the Greenwich Mean Time (GMT) time zone (0,0). If all devices in a fabric are in one time zone, it is possible for you to keep the time zone setup at the default setting.
- System services that have already started will reflect the time zone changes only after the next reboot.
- Time zone settings persist across failover for high availability.
- Time zone settings are not affected by Network Time Protocol (NTP) server synchronization.

The following regions are supported: Africa, America, Arctic, Antarctica, Asia, Atlantic, Australia, Europe, Indian, and Pacific. One of these, along with a city name, establishes the time zone. Refer to [Setting the time zone](#) on page 81.

Time synchronization

To keep the time in your network current, it is recommended that each device has its time synchronized with at least one external NTP server.

All devices in the fabric maintain the current clock server value in nonvolatile memory. By default, this value is the local device clock.

The **ntp server** command accepts multiple server addresses in either IPv4 or IPv6 format. When multiple NTP server addresses are passed, **ntp server** sets the first obtainable address as the active NTP server. If there are no reachable time servers, then the local time is the default time.

Synchronizing local time using NTP

Perform the following steps to synchronize the local time using NTP.

1. Log on to the device using the admin account (the default password is **password**).
2. Enter **configure terminal** to change to global configuration mode.

```
device# configure terminal
Entering configuration mode terminal
```

3. Enter the **ntp server** "*IPv4 address*" command, where *IPv4 address* is the IP address of the first NTP server in IPv4 format, which the device must be able to access. The *IPv4 address* variable is optional. By default, this value is LOCL, which uses the local clock as the clock server.

```
device(config)# ntp server "132.163.135.131"
```

To display the NTP server IP address, use the **show ntp status rbridge-id** *rbridge-id* command. If you are in global configuration mode, you must use **do** before the **show** command.

```
device(config)# do show ntp status rbridge-id 1
```

The request is for the local device unless an RBridge ID is specified. Specify the **all** parameter to send the request to all devices in the cluster.

To remove an NTP server, use the **no** form of the **ntp server** command.

```
devic(config)# no ntp server "132.163.135.131"
```

Setting the time zone

You must perform this procedure on *all* devices for which the time zone must be set. However, you only need to set the time zone once on each device, because the value is written to nonvolatile memory. While not necessary for device operation, setting a time zone is part of ensuring accurate logging and audit tracking. Time zone changes persist through a reboot without having to save the current running configuration.

Use the **clock timezone** command to set the time zone.

1. Log in to the device using an account that has the admin role.
2. Enter the **clock timezone region/city** command while in privileged EXEC mode.

The following example changes the time zone to US/Pacific Standard Time.

```
device# clock timezone America/Los_Angeles
```

Setting the clock (date and time)

The following procedure sets the local clock date and time. An active NTP server, if configured, automatically updates and overrides the local clock time. Time values are limited to between January 1, 1970 and January 19, 2038.

NOTE

You should set the clock only if there are no NTP servers configured. Time synchronization from NTP servers overrides the local clock.

1. Log in to the device using an account that has the admin role.
2. Enter the **clock set year-month-dayT hours:minutes:seconds** command while in privileged EXEC mode.

The following example sets the clock to March 17, 2012, 15 minutes past noon.

```
device# clock set 2012-03-17T12:15:00
```

If you want to show the clock and time zone settings, use the **show clock** command.

```
device# show clock
rbridge-id 1: 2012-03-17 12:15:00 America/Los_Angeles
```

Changing the RBridge ID and VCS ID

If you are planning to connect more than one device in a fabric, each device must have a unique RBridge ID. The default RBridge ID for the device is 1.

If you are planning more than one VCS fabric, each fabric must have a unique VCS ID. The default VCS ID is 1.

If you need to change an Rbridge ID or VCS ID, you can use either of the following commands:

- **vcs set-rbridge-id**: This changes the existing RBridge ID of a node. An option is available for this command to also change the VCS ID.
- **vcs vcsid**: This changes the existing VCS ID of a node. An option is available for this command to also change the RBridge ID.

NOTE

Each time that you change the Extreme Networks VCS Fabric configuration, the device resets to the default configuration and reboot automatically. Make sure to save the configuration before using either of these commands.

For details on using these commands, refer to the *Extreme Network OS Command Reference* and *Extreme Network OS Management Configuration Guide*.

Configuring operating modes on 27x40 GbE line cards

You can configure Performance or Density mode for the port groups on the 27x40 GbE line card . When configured in Performance mode, the third port in the group is persistently disabled, allowing the remaining two ports to operate at up to 40 Gbps. When Density mode (default) is configured, all three ports in the group are enabled, but will operate at below the 40 Gbps maximum rate.

Use the following steps to set Density and Performance modes on port groups on 27x40 GbE line cards.

1. Log in to the device using an account that has the admin role.
2. Power off the line card.

```
device# power-off linecard 3
```

3. Issue the **configure terminal** command to enter global configuration mode.

```
device# configure terminal
Entering configuration mode terminal
```

4. Enter the **hardware** command to enter hardware configuration mode.

```
device(config)# hardware
```

5. Enter the **port-group** command to enter configuration mode for a specific port group.

There are nine port groups on the line card. To identify the port group, use the command with the appropriate values for the *rbridge-id/slot-id/port group-id* parameters. For example, 1/3/9 denotes RBridge ID 1, slot 3, and port group 9.

```
device(config-hardware)# port-group 1/3/9
```

6. Perform one of the following steps:

- Enter the **mode performance** command to configure Performance mode for the port group.

```
device(config-port-group-1/3/9)# mode performance
%Warning: port-group mode performance is a disruptive command.
```

NOTE

Setting Performance mode shuts down the density-only port in the port group. The configuration is allowed only when the slot is powered off and takes effect when the slot is powered on.

Enter the **no mode performance** command to configure Density mode for a port group already configured for Performance mode.

```
device(config-port-group-1/3/9)# no mode performance
%Warning: port-group mode performance is a disruptive command.
```

7. Exit port group configuration mode.

```
device(config-port-group-1/3/9)# exit
```

- Exit hardware configuration mode.

```
device(config-hardware)# exit
```

- Exit global configuration mode.

```
device(config)# exit
device#
```

- Power on the line card.

```
device# power-on linecard 3
```

Displaying operating modes

To display the current operating mode for a specific port group, use the **show running-config hardware port-group** command with the *rbridge-id/slot-id/port group-id* parameters. Note the following responses:

- If "mode performance" displays, the port group is enabled in Performance mode.
- If "no mode performance" displays, the port group is enabled in Density mode.

Verifying correct operation

Complete the following steps to verify correct operation for the device.

- Check the LEDs to verify that all components are functional.
- If necessary, log in to the device by Telnet, using the **admin** account.
- Enter the **show chassis** command to verify that the device and its components are operating correctly.
- Enter the **show interface** command to show the status of all of the ports in the line cards.
- Enter the **show fabric all** command to verify the operation of the device in the fabric.

Backing up a running configuration

NOTE

Extreme Networks recommends that you back up the configuration on a regular basis to ensure that a complete configuration is available for downloading to a replacement management module or chassis. Be sure to append the *date* to the end of the target file names to make it clear which are the latest backups.

You can back up the running configuration to the following locations using the **copy running-config** command.

- Flash memory
- USB device - be sure to use a Extreme Networks branded USB device
- External host

You can also save a single running-configuration backup file across all nodes in the cluster at a specified interval using the **vcs autoconfig-backup timer** command.

For backup procedures, refer to procedures for backing up a running configuration in the *Extreme Network OS Management Configuration Guide*.

Connecting network devices

You can connect your chassis to a variety of network devices. Refer to the following topics for some specific requirements for making these connections.

Connecting to Ethernet devices

For copper connections to a 10/100Base-TX or 1000Base-T device or another Extreme Networks device, a crossover cable is required.

NOTE

The 802.3ab standard (automatic MDI or MDIX detection) calls for automatic negotiation of the connection between two 1000Base-T ports. Therefore, a crossover cable may not be required; a straight-through cable may work as well.

Connecting to workstations, servers, or routers

Straight-through unshielded twisted pair (UTP) cabling is required for direct UTP attachment to workstations, servers, or routers using network interface cards (NICs).

Fiber cabling is required for direct attachment to Gigabit NICs or switches and routers through fiber ports.

Connecting a network device to a fiber port

For direct attachment from the Extreme Networks device to a Gigabit NIC, switch, or router, fiber cabling with an LC connector is required.

Testing connectivity

After you install the network cables, you can test network connectivity to other devices by observing the LEDs related to network connection and performing trace routes.

Installing transceivers and attaching cables

The following two sets of steps cover the installation of transceivers and cables for most SFP and for QSFP transceivers.



CAUTION

Before plugging a cable into any port, be sure to discharge the voltage stored on the cable by touching the electrical contacts to ground surface.

Installing SFP and SFP+ transceivers and cables

Complete the following steps to install optical SFP and SFP+ transceivers.

1. Add the transceivers and cables to the line card ports.

Position one of the optical transceivers so that the key is oriented correctly to the port. Insert the transceiver into the port until it is firmly seated and the latching mechanism clicks.

Transceivers are keyed so that they can only be inserted with the correct orientation. If a transceiver does not slide in easily, ensure that it is correctly oriented.

2. Position a cable so that the key (the ridge on one side of the cable connector) is aligned with the slot in the transceiver. Insert the cable into the transceiver until the latching mechanism clicks.

Cables are keyed so that they can be inserted in only one way. If a cable does not slide in easily, ensure that it is correctly oriented.

3. Repeat step 1 and step 2 for the remaining ports.
4. If you are using direct-attach cables, you can insert them at this time.
5. Organize the cables. Refer to [Managing cables](#) on page 86
6. Verify the device port status using the **show interface** command.
7. Verify fabric connectivity using the **show fabric all** command.

Installing QSFP transceivers and cables

Complete the following steps to install the QSFP transceivers and cables in the 12x40 GbE and 27x40 GbE line cards.

Because each QSFP transceiver consists of four 10 GbE ports, be aware that any problems with one port could affect all four ports in the quad.

1. Position one of the QSFP transceivers so that the key is oriented correctly to the port.
2. Grasping the edges of the transceiver, insert the it into the port until it is firmly seated. You can feel a small click when it completely seats. If your transceiver has a bail, pull the bail up until it latches in the closed position.

Transceivers are keyed so that they can only be inserted with the correct orientation. If a transceiver does not slide in easily, ensure that it is correctly oriented.

When the transceiver is correctly seated, the status LED will turn solid amber.

3. Remove the protective plug from the QSFP transceiver and the protective cap from the special QSFP cable and insert it into the transceiver until it is firmly seated.

The cables are also keyed to fit into the transceivers correctly.

When the cable is correctly seated, the status LED will change from amber to green.

4. Repeat step 1 through step 2 for the remaining QSFP ports.
5. Organize the cables. Refer to [Managing cables](#) on page 86

Managing cables

Cables can be organized and managed in a variety of ways; for example, using cable channels on the port sides of the rack or patch panels to minimize cable management. The cable management comb is located above the modules on the port side of the chassis. Extreme Networks recommends the following best practices for cable management.

- Leave at least 1 m (3.28 ft.) of slack for each port cable. This provides room to remove and replace the device, allows for inadvertent movement of the rack, and helps prevent the cables from being bent to less than the minimum bend radius.
- The minimum bend radius should be no smaller than ten times the cable radius. The minimum radius to which a 50 micron cable can be bent under full tensile load is 5.1 cm (2 in.). For a cable under no tensile load, that minimum is 3.0 cm (1.2 in.).
- If ISL trunking is in use, group the cables by trunking group.
- Generally, Velcro[®] -type cable restraints are recommended to avoid creating sharp bends or kinks in the cables. Do not use tie wraps with optical cables because they are easily overtightened and can damage the optic fibers.
- For easier maintenance, label the fiber-optic cables and record the devices to which they are connected.
- Do not route cables in front of the air intake vents.
- Route the cables to the top of the device through the cable comb.

NOTE

Keep LEDs visible by routing port cables and other cables away from the LEDs. Refer to the "Best Practices for Managing the Cabling" and other Best Practices cabling guides available at <http://www.extremenetworks.com>.

System Monitoring

- System Monitoring overview..... 87
- Determining the status of a line card..... 87
- Determining the status of a management module..... 94
- Determining the status of a switch fabric module..... 96
- Determining the status of a power supply..... 97
- Determining the status of a fan..... 99
- Determining the status of a CID card..... 100

System Monitoring overview

The Extreme Networks device is engineered for reliability and requires no routine operational steps or maintenance. This section provides information about determining the status of each component using LEDs and Extreme Network OS commands.

There are two commands that can be especially helpful in monitoring the health status of various device components. These commands are **show chassis** and the various **show environment** commands. For details about Extreme Network OS commands, refer to the *Extreme Network OS Command Reference*.

Determining the status of a line card

Use the following procedure to determine the status of a line card.

1. Locate the LEDs on the line card. Refer to the line card illustrations in the following sections.
The LED patterns may temporarily change during POST and other diagnostic tests. For information about how to interpret the LED patterns, refer to [Interpreting the line card LED indicators](#) on page 92.
2. Use the **show linecard** or **show slots** command to determine if the line cards are enabled. The line cards are labeled L1 through L8 in the output. The **show linecard** command limits the output to the line card slots only.
3. Use the **show interface** command to determine the status of the interfaces (ports) on the line card.

Locating the LEDs on the line card

Use the following illustrations to locate the LEDs on the line cards available on the device. Full views and close-ups are provided for each line card.

8x10 GbE line card

FIGURE 43 48x10 GbE line card (full view and close-up)

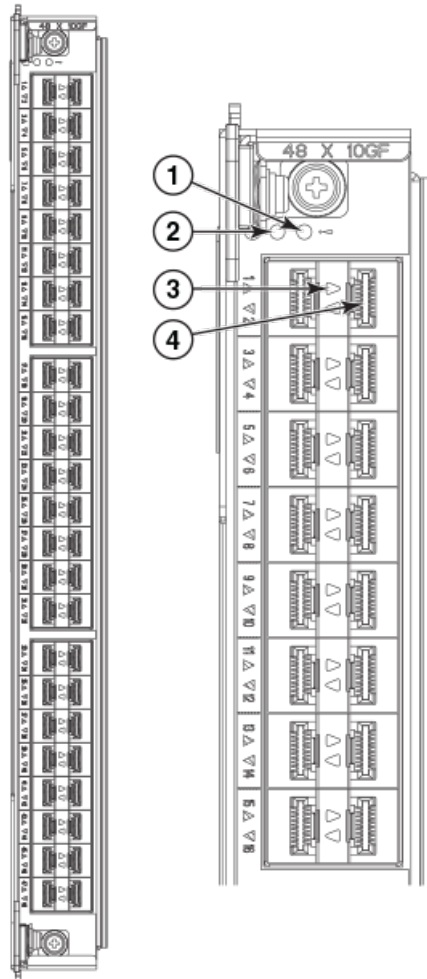

- 1. Status LED
- 2. Power LED

- 3. Port Status LED
- 4. GbE port

12x40 GbE line card

FIGURE 44 12x40 GbE line card (full view and close-up)

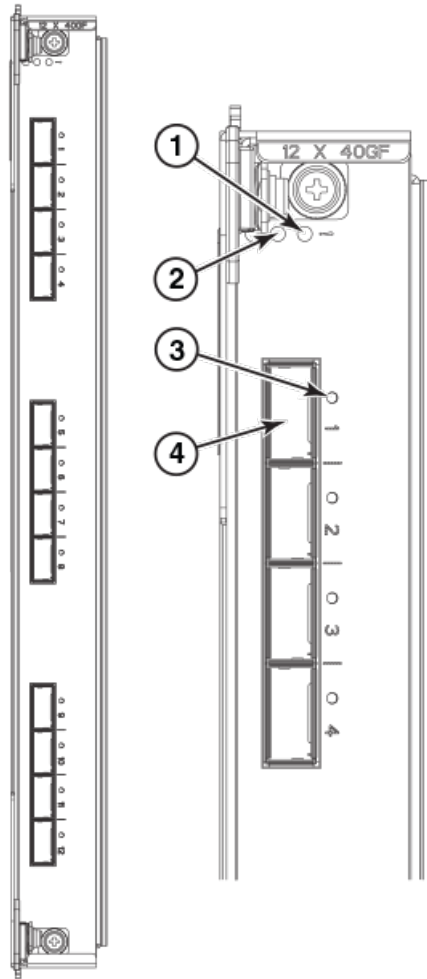

- 1. Status LED
- 2. Power LED

- 3. Port Status LED
- 4. GbE port

27x40 GbE line card

FIGURE 45 27x40 GbE line card (full view and close-up)

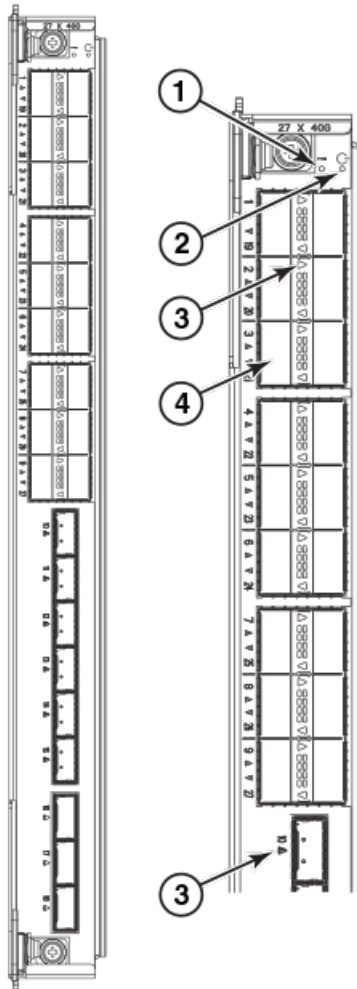

1. Status LED
2. Power LED
3. 3. 40 GbE Port Status LED
4. 40 GbE Port

48x10G-T line card

FIGURE 46 48x10G-T line card (full view and close-up)

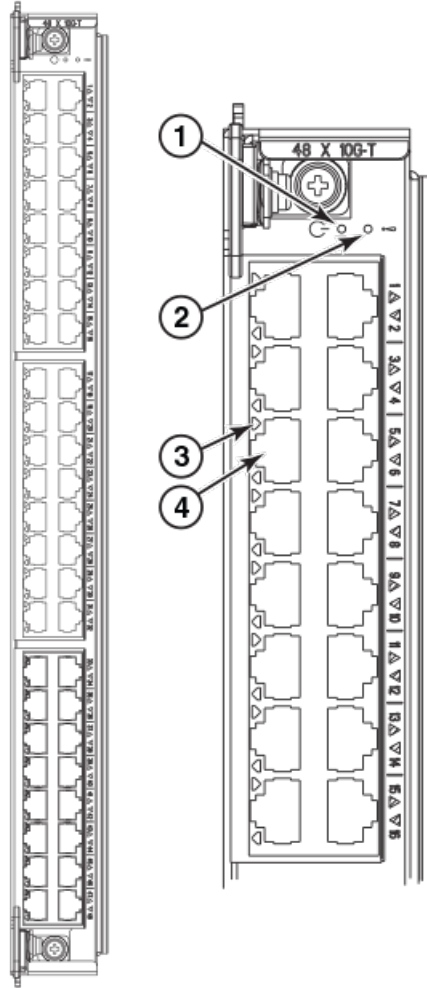

- 1. Power LED
- 2. Status LED

- 3. Port Status LED
- 4. 10 GbE port

6x100 GbE line card

FIGURE 47 6x100 GbE line card (full view and close-up)

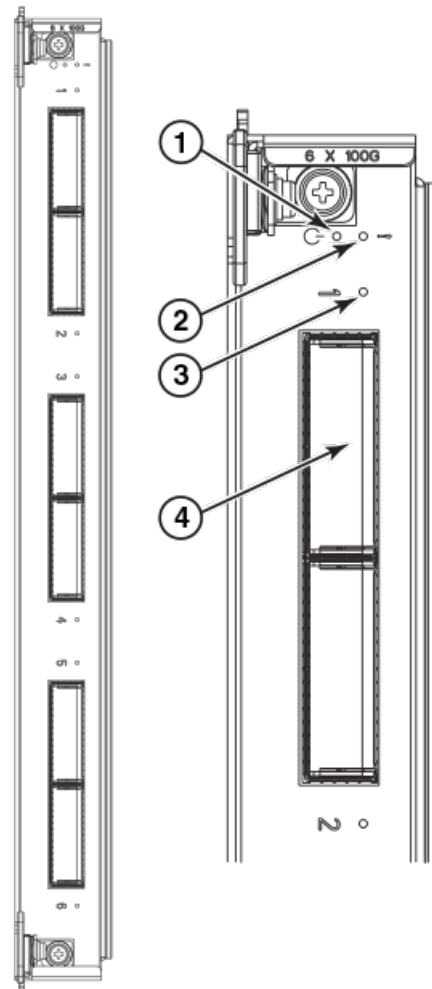

- 1. Power LED
- 2. Status LED

- 3. Port Status LED
- 4. 100 GbE port

Interpreting the line card LED indicators

Use the following table to interpret the line card LED indications and to determine the recommended actions for each pattern.

NOTE

When the 40 GbE ports are in breakout mode on the 27x40 GbE and 12x40 GbE line cards, operating status cannot be determined from LED operation.

TABLE 10 Line card LED descriptions

LED purpose	Color	Status	Recommended action
Power LED 	No light (LED is off)	Module is not powered on.	Ensure that the module is firmly seated and either the thumbscrew is fully engaged or the slider is

TABLE 10 Line card LED descriptions (continued)

LED purpose	Color	Status	Recommended action
			pushed up and the ejectors are fully engaged.
	Steady green	Module is powered on.	No action required.
Status LED 	No light (LED is off) Power LED steady green.	Module is operational.	No action required.
	No light (LED is off) Power LED is off.	No power.	No action required.
	Steady amber	Module is faulty or module is booting up.	If module is not booting up, ensure that the module is firmly seated and check the status by entering the show slot command. If the LED remains amber, consult your Extreme Networks supplier.
	Flashing amber	Module is not seated correctly.	Pull the module out and reseat it. If the LED remains amber, replace the module.
10 GbE Port Status (48x10 GbE line card) or 1 GbE Port Status (48x1 GbE line card)	No light (LED is off)	The pluggable module (SFP/QSFP/CFP) is not inserted in the port cage or the module is inserted, but no external link is connected.	Verify that the power LED is on, check the transceiver and cable.
	Steady green	The port is online but has no traffic.	No action required.
	Flickering green	The port is online with traffic flowing through the port.	No action required.
	Steady amber	The port is receiving light but it is not online yet.	Reset the port by issuing a shutdown and no shutdown command sequence on the port.
	Slow flashing amber (on 2 seconds, then off 2 seconds)	The port is disabled.	Enable the port by issuing the no shutdown command.
	Fast flashing amber (on 1/4 second, then off 1/4 second)	The transceiver or port is faulty.	Change the transceiver or reset the port by issuing a shutdown and no shutdown command sequence.
	Slow flashing green (on 2 seconds, then off 2 seconds)	The port is online but segmented (either a loopback cable or incompatible device connection).	Consult the <i>Extreme Network OS Troubleshooting Guide</i> .
	Medium flashing green (on 1 seconds, then off 1 seconds)	Beaconing (used to identify specific ports).	No action required.
	Fast flashing green (on 1/2 second, then off 1/2 second)	Internal loopback (diagnostic).	In diagnostic mode. Will return to regular mode when diagnostic is finished.
40 GbE QSFP Port Status (12x40 GbE or 27x40 GbE line card) in 40 GbE mode	No light (LED is off)	There is no QSFP transceiver installed.	Verify that the power LED is on, ensure the transceiver is fully seated or install the transceiver.
	Steady green	The port is online but has no traffic.	No action required.
	Flickering green	The port is online with traffic flowing through the port.	No action required.
	Steady amber	The port is receiving light but it is not online yet.	Reset the port by issuing a shutdown and no shutdown command sequence on the port.
	Slow flashing amber (on 2 seconds, then off 2 seconds)	The port is disabled.	Enable the port by issuing the no shutdown command.

TABLE 10 Line card LED descriptions (continued)

LED purpose	Color	Status	Recommended action
	Fast flashing amber (on 1/4 second, then off 1/4 second)	The transceiver or port is faulty.	Change the transceiver or reset the port by issuing a shutdown and no shutdown command sequence.
	Slow flashing green (on 2 seconds, then off 2 seconds)	The port is online but segmented (either a loopback cable or incompatible device connection).	Consult the <i>Extreme Network OS Troubleshooting Guide</i> .
	Medium flashing green (on 1 seconds, then off 1 seconds)	Beaconing (used to identify specific ports).	No action required.
	Fast flashing green (on 1/2 second, then off 1/2 second)	Internal loopback (diagnostic).	In diagnostic mode. Will return to regular mode when diagnostic is finished.
10 GbE Port Status (48x10G-T line card)	No light (LED is off)	No power to the Line card.	Verify that the power LED is on, check the transceiver and cable.
	Steady amber	The port is receiving light but it is not online yet.	Reset the port by issuing a shutdown and no shutdown command sequence on the port.
	Slow flashing amber (on 2 seconds, then off 2 seconds)	The port is disabled.	Enable the port by issuing the no shutdown command.
	Steady green	The port is online but has no traffic.	No action required.
	Flickering green	The port is online with traffic flowing through the port.	No action required.
	Medium flashing green (on 1 seconds, then off 1 seconds)	Beaconing (used to identify specific ports).	No action required.
100 GbE Port Status (6x100 GbE line card)	No light (LED is off)	There is no transceiver installed' or no external link connected	Verify that the power LED is on, ensure the transceiver is fully seated or install the transceiver.
	Steady green	The port is online but has no traffic.	No action required.
	Flickering green	The port is online with traffic flowing through the port.	No action required.
	Medium flashing green (on 1 seconds, then off 1 seconds)	Beaconing (used to identify specific ports).	No action required.
	Steady amber	The port is receiving light but it is not online yet.	Reset the port by issuing a shutdown and no shutdown command sequence on the port.
	Slow flashing amber (on 2 seconds, then off 2 seconds)	The port is disabled.	Enable the port by issuing the no shutdown command.

Determining the status of a management module

You must have at least one management module (MM) active for the chassis to be functional. For redundancy, you need two management modules. The active management module is designated by the blue Active LED on the front panel.

Complete the following steps to determine the status of an management module.

1. Locate the LED indicators on the management module ([Locating the LED indicators on the management module](#) on page 95).
2. Observe and interpret the LED pattern. The LED patterns may temporarily change during POST and other diagnostic tests. For information about how to interpret the LED patterns, refer to [Interpreting the management module LED patterns](#) on page 95.

- Use the **show mm** command to determine whether the management modules are enabled. You can also use the **show interface management 1/1** command to see the configuration information.

Locating the LED indicators on the management module

Use the following illustration to identify the LEDs on the management module.

FIGURE 48 Management module

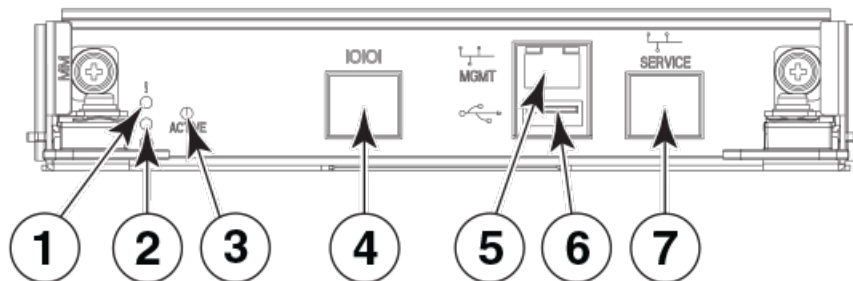



- | | |
|--------------------------|-------------------------------|
| 1. Status LED | 5. Ethernet port (Mgmt IP) |
| 2. Power LED | 6. USB port |
| 3. Active LED | 7. Ethernet port (Service IP) |
| 4. Console port (Serial) | |

Interpreting the management module LED patterns

Use the following table to interpret the management module LED patterns and to determine the recommended action for each pattern.

TABLE 11 Management module LED descriptions

LED purpose	Color	Status	Recommended action
Power 	Steady green	MM is powered on.	No action required.
	No light (LED is off)	MM is not powered on.	Ensure that the module is firmly seated and has power.
Status 	No light (LED is off)	MM is either healthy or does not have power.	Verify that the power LED is on.
	Steady amber	MM requires attention or is still booting up.	If the LED remains amber, the module is faulty. Consult your supplier.
Active	Steady blue	Module is the active MM.	No action required.
	No light (LED is off)	Module is booting up, negotiating to be the active MM, or is the standby MM.	No action required.
Ethernet management link (upper left)	Steady green	Ethernet link speed is 1000 Mbps (1 Gbps).	No action required.
	No light (LED is off)	There is no link or link speed is 10 or 100 Mbps.	No action required.
Ethernet management link activity (upper right)	Blinking green	Ethernet link is healthy and traffic is flowing through port.	No action required.
	No light (LED is off)	No traffic is flowing.	No action required.

Determining the status of a switch fabric module

At least one functional switch fabric module (SFM) must be plugged into slots S3 or S4 (the "control plane slots"). If there are no functional switch fabric modules in either slot during bootup, bootup is halted with a message indicating that condition.

In an operational chassis, if all switch fabric modules in the control plane slots become faulty or are removed, then all the line cards will be faulted with a reason code that indicates no availability of a switch fabric module. An external RASlog message will also be displayed.

Complete the following steps to determine the status of a switch fabric module.

1. Locate the LED indicators on the switch fabric module (refer to [Locating the LED indicators on the switch fabric module](#) on page 96). The LED patterns may temporarily change during POST and other diagnostic tests. For information about how to interpret the LED patterns, refer to [Interpreting the switch fabric module LED indicators](#) on page 96.
2. Use the **show sfm** command or the **show slots** command to see whether the switch fabric module is enabled.

Locating the LED indicators on the switch fabric module

Use the following illustration to identify the LEDs on the switch fabric module.

FIGURE 49 Switch fabric module

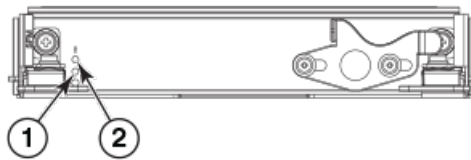

1. Power LED

2. Status LED

Interpreting the switch fabric module LED indicators

Use the following table to interpret the switch fabric module LED patterns and to determine the recommended actions for each pattern.

TABLE 12 Switch fabric module LED descriptions



LED purpose	Color	Status	Recommended action
Power 	No light (LED is off)	SFM is not on.	Ensure that the SFM is firmly seated, the power switch is turned on, and the slider is covering the captive screw. If the slider is out of position and not covering the screw, the switch will not recognize the SFM (may show as vacant in show slots output) and may result in line card and standby management module faults.
	Steady green	SFM is on.	No action required.
Status 	No light (LED is off)	SFM is healthy or is not powered on.	Verify that the power LED is on.
	Steady amber	SFM is faulty.	Ensure that the SFM is firmly seated and check the status by entering the show slot command. If the LED remains amber, consult the Extreme Networks supplier.

TABLE 12 Switch fabric module LED descriptions (continued)

LED purpose	Color	Status	Recommended action
	Slow flashing amber (on 2 seconds, then off 2 seconds)	SFM is not seated correctly or is faulty.	Pull the SFM out and reseal it. If the LED remains amber, replace the module.
	Fast flashing amber (on 1/2 second, then off 1/2 second)	Environmental range exceeded.	Check for the out-of-bounds environmental condition and correct it.

Determining the status of a power supply

Complete the following steps to determine the status of a power supply.

1. Locate the alarm LED labeled ALM on the power supply.
2. Observe and interpret the LED pattern.
3. Verify the power supply status

Locating the alarm LED on the power supply

Use the following illustration to locate the alarm LED labeled ALM on the power supply.

FIGURE 50 Power supply

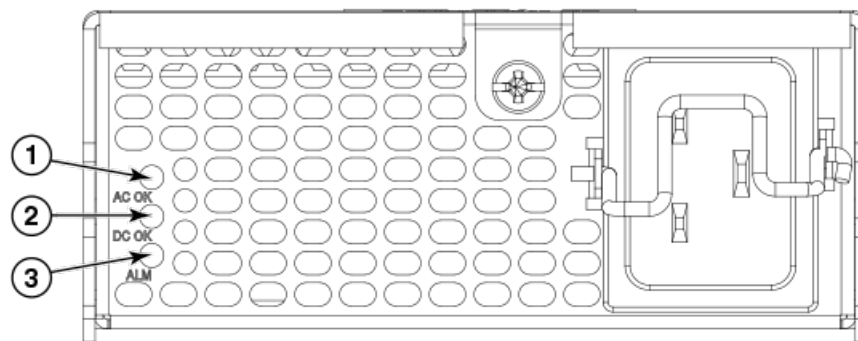

- | | |
|--------------------------------|--------------------|
| 1. AC power input LED (AC OK) | 3. Alarm LED (ALM) |
| 2. DC power output LED (DC OK) | 4. |

Use the following table to interpret the power supply LED patterns and to determine the recommended action for each pattern.

The LED patterns may temporarily change during POST and other diagnostic tests.

The VDX 8770-4 can have up to four power supplies. Be sure to check each module.

TABLE 13 Power supply LED descriptions

LED purpose	Color	Status	Recommended action
AC OK	No light (LED is off)	Power supply does not have incoming AC power.	If using AC power, ensure that the power supply is firmly seated, the AC power source is live, and the power cable is connected.
	Steady green	Power supply has incoming AC power.	No action required.

TABLE 13 Power supply LED descriptions (continued)

LED purpose	Color	Status	Recommended action
DC OK	No light (LED is off)	The DC output is not in the acceptable range.	Ensure that the power supply is firmly seated.
	Steady green	The DC output is in the acceptable range.	No action required.
ALM	No light (LED is off)	The power supply has not failed.	No action required.
	Steady amber	The power supply has failed.	Replace the power supply.

Verifying the power supply status

You can check the power supply status by entering the **show environment power** command. Use the following table to interpret the command output. You can also use the **show system** command.

TABLE 14 Output for show environment power command

Output	Explanation
OK	Power supply is functioning correctly.
absent	Power supply is not present. Could also be improperly seated.
unknown	Unknown power supply unit installed.
predicting failure	Power supply is present but predicting failure.
faulty	Power supply is present but faulty (no power cable, power switch turned off, fuse blown, or other internal error). Could also be improperly seated.

For absent or faulty indications, if the power supply is not improperly seated, contact your Extreme Networks supplier to order replacement parts. You may also want to do this if the indication is predicting failure.

Determining the status of a fan

Complete the following steps to determine the status of a fan.

1. Locate the LED indicators on the fan. The LED patterns may temporarily change during POST and other diagnostic tests. The VDX 8770-4 has up to two fans. Be sure to check each module.

FIGURE 51 Fan module led indicators

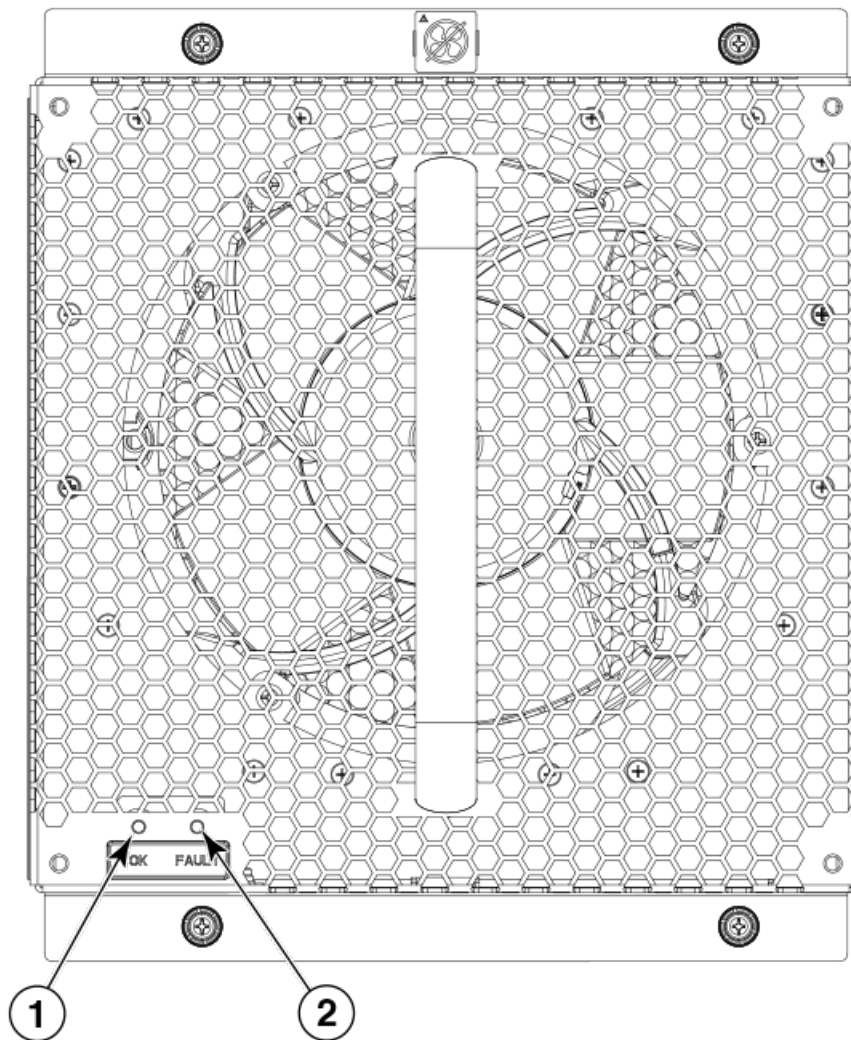

1. Power LED

2. Fault LED

- Interpret the LED indicators and take the appropriate action.

TABLE 15 Fan LED descriptions

LED purpose	Color	Status	Recommended action
OK	No light (LED is off)	Fan does not have power.	Ensure that the fan is firmly seated and has power.
	Steady green	Fan has power.	No action required.
Fault	No light (LED is off)	Fan is either healthy or does not have power.	Ensure that the fan has power.
	Steady amber	Fan has a failure (full or partial).	Replace the fan.

- Determine the fan status using the **show environment fan** command. (Alternately, you can use the **show system** command.)

TABLE 16 Output for show environment fan command

Output	Explanation	Recommended action
OK	The fan is functioning correctly at the displayed speed (RPM).	No action is required.
absent	A fan is not present, or the fan is improperly seated.	Contact your Extreme Networks supplier to order replacement parts.
below minimum	A fan is present but rotating too slowly or stopped.	
above maximum	The fan is rotating too quickly.	
unknown	An unknown fan unit is installed.	
faulty	The fan has exceeded hardware tolerance and has stopped. In this case, the last known fan speed is displayed. A faulty indicator could also mean that the fan is improperly seated.	

Determining the status of a CID card

Each CID card has two serial EEPROMS (seeproms). One is the critical seeprom and the other is the non-critical seeprom. Problems with the critical seeprom cannot be fixed with the CID Recovery Tool. Only issues with the non-critical seeprom can be addressed.

Regular validation tests are run by the system comparing the CID cards to each other. If the information is identical, then the chassis is operating correctly. Once a mismatch is detected, an FFDC message is output to the RASlog. Refer to following table for possible messages.

TABLE 17 Messages that may indicate CID card problems

Error message	Issue
[EM-1020]...M1, ERROR ... A problem was found on one or both CID cards (x), please run the CIDrecov tool to get more information and recovery options.	Some kind of error or mismatch has been detected in the CID card audit.
[EM-1021], ... M1, INFO, ... A CID card has been inserted, a CID verification audit will be run to detect any mismatches or other problems.	A second CID card is enabled and the CID card audit will be run. If an error is detected during the audit, an EM-1020 message is generated.
[EM-1022], ... M1, WARNING, ... A CID card access problem has been encountered, please run the CIDrecov tool to get more information and recovery options.	An error is detected during normal access to the CID cards; typically, one of the cards is corrupted or inaccessible.

Removal and Replacement Procedures

- Introduction..... 101
- ESD precautions..... 101
- Cable management comb removal and replacement..... 102
- Line card removal and replacement..... 103
- CFP2 to QSFP28 Conversion Module removal and replacement..... 106
- Management module removal and replacement..... 108
- Switch fabric module removal and replacement..... 110
- Power supply removal and replacement..... 113
- Fan removal and replacement..... 116
- Air filter removal and replacement..... 117
- Module filler panel removal and replacement..... 119
- Chassis ID card removal and replacement..... 120
- SFP transceiver removal and replacement..... 120
- QSFP transceiver removal and replacement..... 122
- Cable routing table..... 123
- Air filter removal and replacement..... 124

Introduction

NOTE

Read the [Cautions and Danger Notices](#) on page 139 and translations at the end of this manual before servicing.

The field-replaceable units (FRUs) can be removed from the device and replaced without special tools. The device can continue operating during many of the FRU replacements if the conditions specified in the procedures are followed.

The following sections contain FRU removal and replacement procedures.

ESD precautions

The device contains ESD-sensitive FRUs. When working with any Extreme FRU, use correct electrostatic discharge (ESD) procedures.

- Wear a wrist grounding strap connected to chassis ground (if the device is plugged in) or a bench ground. Refer to [ESD precautions](#) for the location of the ESD jack.



DANGER

For safety reasons, the ESD wrist strap should contain a series 1 megaohm resistor.

- Store ESD-sensitive components in anti-static packaging.



CAUTION

Static electricity can damage the chassis and other electronic devices. To avoid damage, keep static-sensitive devices in their static-protective packages until you are ready to install them.

Cable management comb removal and replacement

You can continue to operate the device during the replacement of the cable management comb.

Time and items required

The replacement procedure for the cable management comb takes less than 5 minutes. A #1 Phillips screwdriver is required.

Removing a cable management comb

Complete the following steps to remove the cable management comb. Refer to the illustration provided with the procedure.

1. Remove the cables from the cable management comb and rearrange the cables around the comb.
2. Unscrew and save the four (4) screws holding the cable management comb to the chassis. Retain the screws. Support the cable management comb to prevent it from falling.
3. Remove the cable management comb.

FIGURE 52 Removal and replacement of the cable management comb

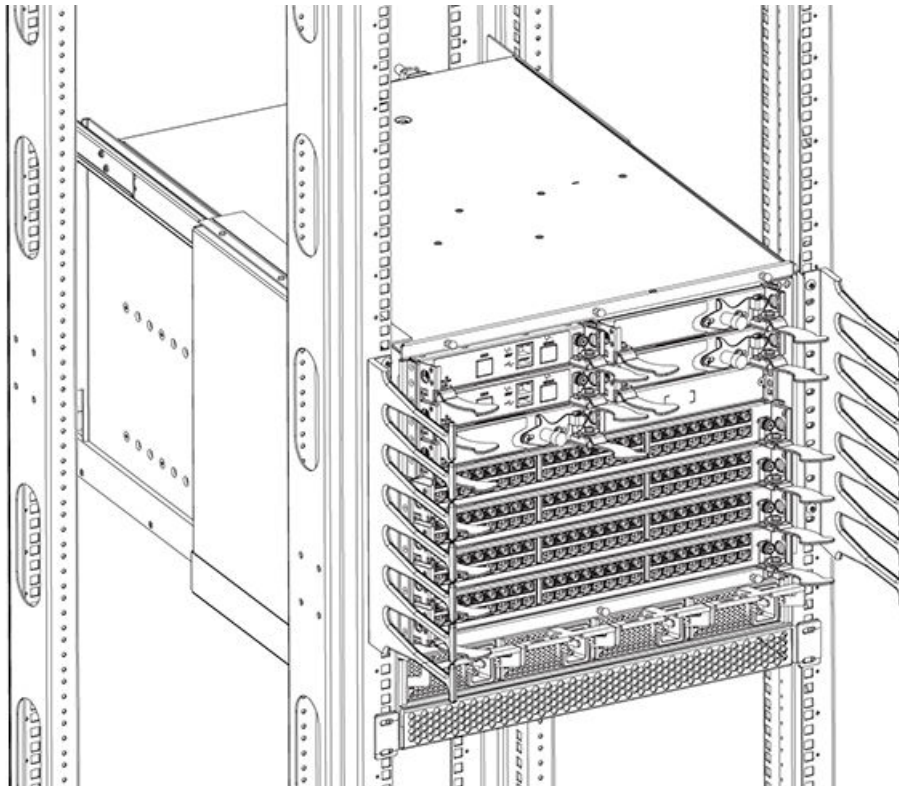

Replacing a cable management comb

Complete the following steps to replace the cable management comb.

1. Position and tighten the four (4) screws to secure the new cable management comb to the chassis.
2. Arrange the cables in the cable management comb.

Line card removal and replacement

This section describes the physical procedure for removing and replacing line cards in chassis slots. It does not cover the management modules or the switch fabric modules.

If are replacing a line card with a different type of line card, after removing the original line card, you must enter the Extreme Network OS **no linecard slot_number** command while in RBridge ID configuration mode to clear the current slot configuration. You must also select the new line card type using the **linecard slot_number linecard_type** command before installing the new line card. For more detailed command steps, consult procedures in this section for removing and replacing a line card and in the *Extreme Network OS Management Configuration Guide*.

Install a new line card only if it is supported by the firmware running in the chassis. Inserting a line card into a chassis running firmware that does not support the line card may result in unexpected behavior.

NOTE

Any slot that is not occupied by a line card should be occupied by a filler panel to ensure correct cooling of the chassis and protection from dust.

Time and items required

The replacement procedure for each line card takes less than 10 minutes. Removing and restoring transceivers and cables may take longer depending on how many must be changed. The following items are required for the line card replacement:

- Electrostatic discharge (ESD) grounding strap
- Workstation computer
- Replacement line card or filler panel
- #2 Phillips screwdriver
- Small form-factor pluggable (SFP or SFP+) or QSFP transceivers (as needed)
- Optical and copper cables (as needed)

For details on supported transceivers, refer to the following publications on www.extremenetworks.com:

- *ExtremeSwitching VDX Transceiver Support Matrix*.
- *Extreme Fibre Channel Transceiver Support Matrix*.

Removing a line card

Complete the following steps to remove a line card.

NOTE

If multiple modules are being replaced, complete the replacement for one module at a time.

NOTE

Follow ESD precautions while removing any line card. Refer to [ESD precautions](#) on page 101.

1. Check for adequate cable slack. Ensure there is plenty of cable slack to remove a line card without cable obstruction.
2. Ensure that the part number on the line card being replaced matches the replacement part number.
3. Power down the existing line card using the **power-off linecard slot_number** command.

NOTE

Before removing any cables from a line card, note the cable order (identify each cable by its physical port). It is a good practice to keep a table of cable to port mapping. Refer to [Cable routing table](#) on page 123 for a blank cable routing table.

4. If you are replacing the line card with a line card of a different type, follow these steps:
 - a) Enter the **configure terminal** command to enter global configuration mode
 - b) Enter the **rbridge-id rbridge-id** command to enter RBridge ID configuration mode.
 - c) Enter the **no linecard slot_number** command. This command removes the line card configuration and its associated interface configuration from the chassis database so a different type of line card can be used in the slot.
5. Disconnect all cables and transceivers from the line card.
6. Unscrew the two captive screws at the ends of the line card using the Phillips screwdriver.
7. Open the ejectors by rotating them toward the center of the line card face. Pull the line card out of the chassis using the ejectors.

FIGURE 53 Removal and replacement of the line card

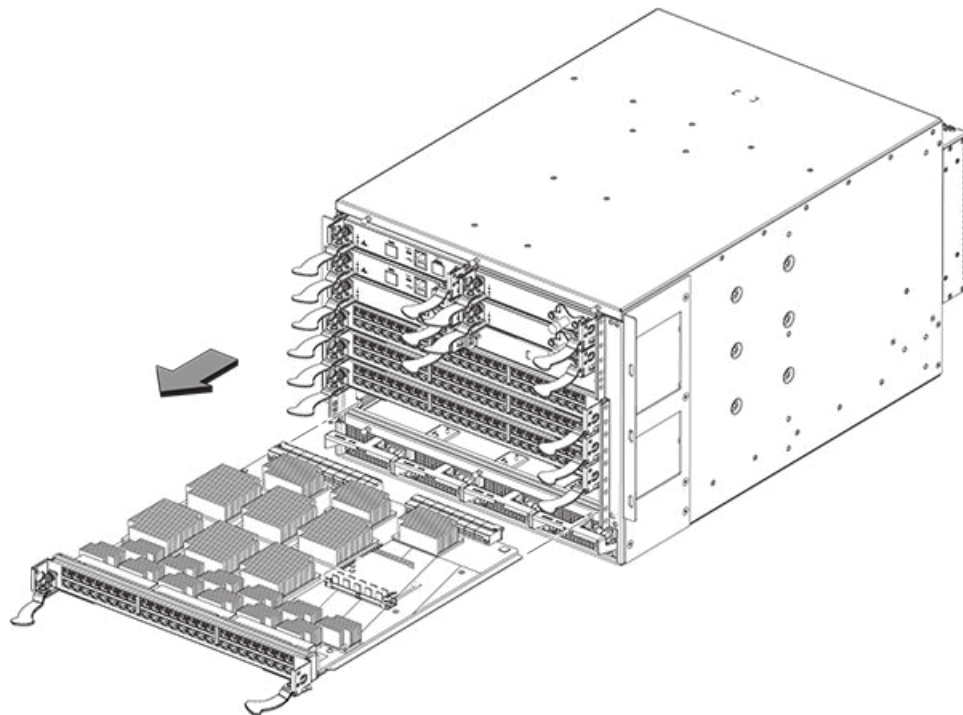

8. If you are replacing the line card with a line card of a different type, follow these steps before replacing the line card.
 - a) Enter the **linecard slot_number** command followed by a question mark (?) to display the line card types.
 - b) Enter the **linecard slot_number linecard_type** command using the proper line card type.
 - c) Enter the **exit** command twice to return to privileged EXEC mode.

Replacing a line card

Review the [ESD precautions](#) on page 101 before replacing a line card.

Complete this procedure to insert a new line card. Refer to the illustration provided with the procedure.

1. If you are replacing the line card with a line card of a different type, follow these steps:
 - a) Make sure that you have cleared the configuration for the original line card from the chassis database using steps under [Removing a line card](#) on page 103.
 - b) Enter the **linecard slot_number** command followed by a question mark (?) to display the current line card types.
 - c) Enter the **linecard slot_number linecard_type** command using the proper line card type for the new line card.
 - d) Enter the **exit** command twice to return to privileged EXEC mode.
2. Unpack the new line card and remove it from the anti-static bag.
3. Inspect the line card for damage.
4. Remove the protective covers from the backplane connectors.
5. Orient the line card so that the ports are at the front of the device.
6. Open the ejectors by rotating them toward the center of the line card face and align the flat side of the line card inside the top and bottom rail guides in the slot. Line cards can be inserted in any of the slots labeled L1 through L8.
7. Slide the line card all the way into the slot.
8. Close the ejectors by rotating them away from the center of the line card. The levering action of the ejectors seats the line card in the slot.
9. Tighten the captive screws using the Phillips screwdriver.
10. Check to see if the line card has powered on. If not, power on the line card using the **power-on linecard slot_number** command.

Verify that the power LED on the line card is displaying a steady green light. If it does not turn on, ensure that the line card is firmly seated.

The status LED on the line card will show amber until POST completes for the line card. It should then turn off. If it remains amber, the line card may not be properly seated in the backplane or the line card may be faulty.
11. If you have replaced a line card with a line card of a different type, follow these steps:
 - a) Back up the running configuration using steps in [Backing up a running configuration](#) on page 83.
 - b) Verify the configuration by issuing the **show running-config linecard** linecard command.
12. Reinstall the transceivers and cables in the line card or install new transceivers and cables if you have installed a different type of line card.
13. Group and route the cables through the cable management device.

CFP2 to QSFP28 Conversion Module removal and replacement

Use procedures in this section to remove and replace a CFP2 to QSFP28 Conversion Module. These modules install in 6x100 GbE line card 100 GbE CFP2 ports to allow connection with 100 GbE QSFP28 ports.

Removing a CFP2 to QSFP28 conversion module

Use the following steps to remove the CFP2 to QSFP28 Conversion Module from a 6x100 GbE line card port. Reference the following figure as you perform these steps.

FIGURE 54 Removing CFP2 to QSFP28 Conversion Module

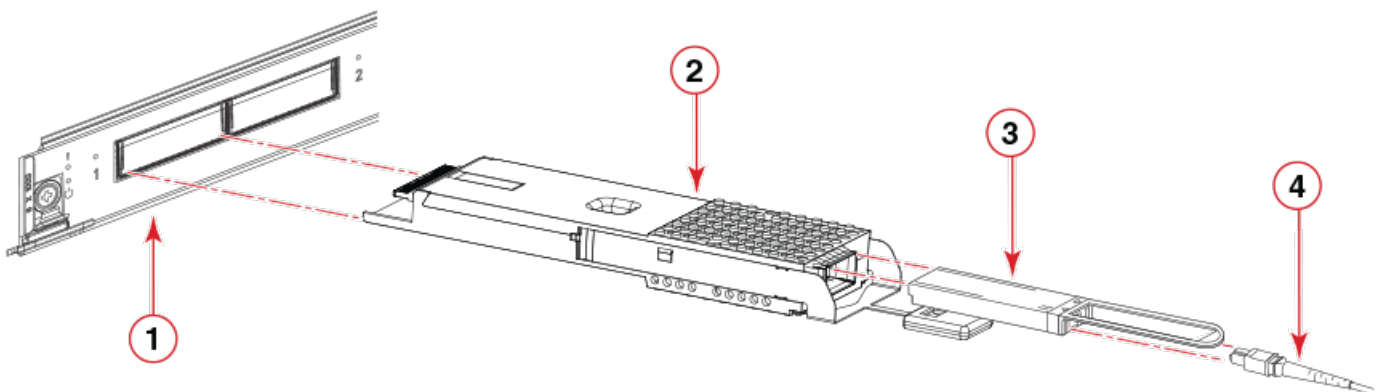

- | | |
|-------------------------------------|-------------------------------|
| 1. 100 GbE CFP2 port | 3. 100 GbE QSFP28 transceiver |
| 2. CFP2 to QSFP28 Conversion Module | 4. QSFP to QSFP cable |

1. Unplug the QSFP to QSFP optical cable by grasping the cable connector and pulling it straight out from the QSFP28 transceiver while pushing in on the transceiver pull tab.
2. Remove the conversion module and QSFP28 transceiver by grasping the conversion module pull tab and pulling module straight out from port.

NOTE

To remove the QSFP28 transceiver from the conversion module, pull the transceiver out by its pull tab while pushing in on the conversion module pull tab.

3. Place the conversion module and transceiver in protective packing for safe-keeping.

Replacing a CFP2 to QSFP28 conversion module

Use the following steps to install the CFP2 to QSFP28 Conversion Module and QSFP28 transceiver into ports on the 6x100 GbE line card installed in VDX 8770 devices.

1. If a CFP2 100 GbE transceiver is installed in the port where you want to install the conversion module, remove the transceiver by pulling it straight out from the port using the transceiver pull tab.
2. Place the transceiver in protective packing for safe-keeping.

3. Orient the module as shown in the following illustration and slide into the port using the module's pull tab until it locks into place.

FIGURE 55 Installing CFP2 to QSFP28 Conversion Module

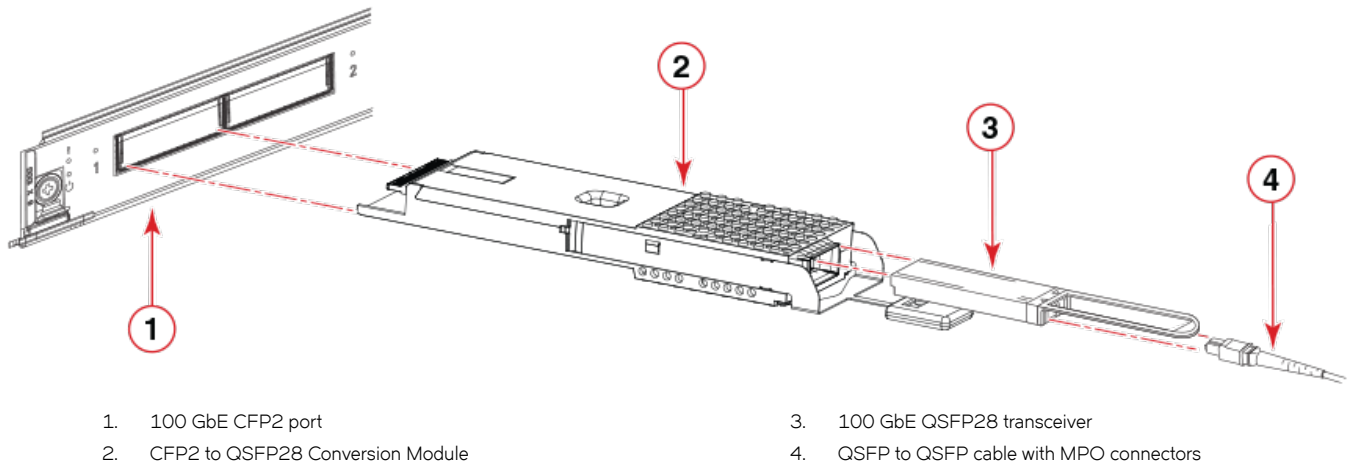

4. Insert the Extreme Networks QSFP28 100 GbE transceiver into the conversion module using the transceiver pull tab until it locks into place.
The LED on the conversion module should turn amber when conversion module with appropriate transceiver are installed in the port.
5. Plug the QSFP to QSFP optical cable from the VDX 6940-144S into the transceiver.
The LED on the conversion module should turn green when connection is complete and link is active.

- Enter the **show media interface** command for the port to verify that QSFP28 displays as the media identifier when the conversion module with QSFP28 transceiver are properly installed.

```
sw0# show media interface hundredgigabitethernet 1/8/1
Interface      HundredGigabitEthernet 1/8/1
Identifier     11   QSFP28
Connector     12   MPO Parallel Optic
Transceiver    000000000000000004 40_GB/s Short_dist
Name          sw
Encoding      5    IEEE 802.3ab
Baud Rate     103 (units 100 megabaud)
Length 9u     0    (units km)
Length E-50u  150 (units 2 meters)
Length 50u    0    (units 1 meters)
Length 62.5u  0    (units 1 meters)
Length Cu     0    (units 1 meter)
Vendor Name   EXTREME NETWORKS
Vendor OUI    00:05:1e
Vendor PN     57-1000296-01
Vendor Rev    A
Wavelength   17000(units 0.05 nm)
Options      0000
BR Max       15
BR Min       222
Serial No    LVA114230000411
Date Code    140607
Optical Monitor yes
Temperature  28 Centigrade
Voltage      3286.8 (mVolts)
Current      6.744 (mAmps)
TX Power     N/A
RX Power     792.9 (uWatts)
```

Note that when the line card's CFP2 transceiver installed instead of the conversion module, output from the **show media interface** command would display "CFP2" as the media identifier instead of "QSFP28".

Management module removal and replacement

This section describes how to remove and replace a management module (MM). Each device can have one or two management modules. They reside in slots M1 and M2. There must be at least one management module installed for the chassis to operate.

Time and items required

The replacement procedure for the management module takes approximately 30 minutes. The following items are required for the management module replacement:

- ESD grounding strap
- Workstation computer
- Serial cable
- IP address of an FTP server for backing up the configuration
- #2 Phillips screwdriver
- Replacement management module

Faulty management module indicators

Confirm that you need to replace the management module. The following events might indicate that a management module is faulty:

- The status LED on the management module is lit steady amber, or the power LED is not lit.
- The management module does not respond to Telnet commands, or the serial console is not available.
- The **show mm** command does not show that the management module is enabled.
- Additional information from the **show mm** command indicates a problem.
- The clock is inaccurate, or the management module does not boot up or shut down normally.

For more information about error messages, refer to the *Extreme Network OS Message Reference*.

Recording critical configuration information

Back up the chassis configuration before you replace a management module. Refer to [Recording critical configuration information](#) for backup information.

Removing a management module

Refer to [ESD precautions](#) on page 101 before removing a management module.

The chassis continues to operate while a management module is being replaced if the redundant management module is active and a failover has already occurred.

Complete the following steps to remove a management module. Refer to the illustration provided with the procedure.

1. Remove any cables connected to the module.
2. Unscrew the captive screws from both ejectors using the Phillips screwdriver.
3. Rotate both ejectors simultaneously toward the center of the module.

4. Pull the management module out of the chassis by the ejectors.

FIGURE 56 Removal and replacement of the management module

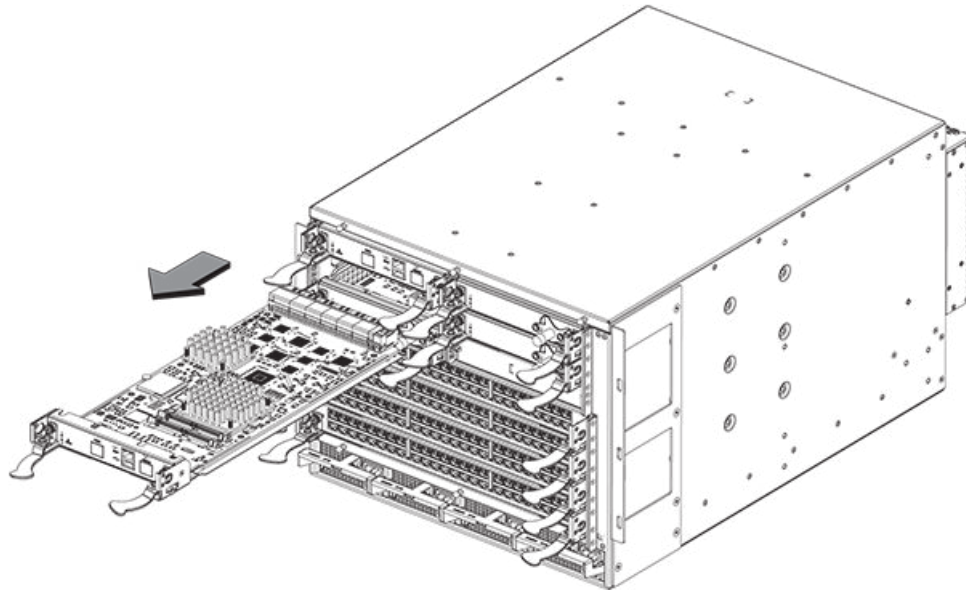

Replacing a management module

Refer to [ESD precautions](#) on page 101 before replacing a management module.

Complete the following steps to insert an management module. Refer to the illustration provided in [Removing a management module](#) on page 109.

1. Unpack the new management module and remove it from the anti-static bag.
2. Inspect the module for damage.
3. Remove the protective caps from the backplane connectors.
4. Rotate the ejectors toward the center of the module.
5. Align the module pan with the guides in the slot. The first management module should be installed in slot M1.
6. Slide the management module into the slot until it is firmly seated.
7. Rotate the ejectors away from the center of the module face until the module is tight in the slot.
8. Tighten the captive screws using the Phillips screwdriver. Verify that the power LED is green. If not, ensure that the management module has power and is firmly seated and that the ejectors are in the locked position.
9. Reconnect any cables that were attached to the old module.

Switch fabric module removal and replacement

The VDX 8770-4 has up to three Switch fabric modules (SFMs). The modules can be installed only in slots S1 through S3. There must be at least one switch fabric module installed in either slot S1 or slot S2.

FIGURE 57 Switch Fabric Module front view

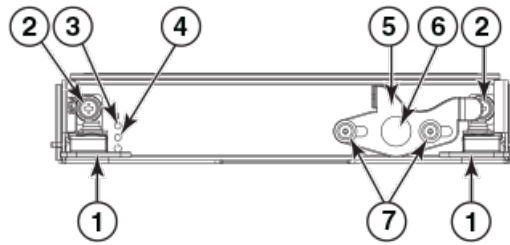

- | | |
|-------------------|---------------------|
| 1. Ejectors | 5. Slider |
| 2. Captive screws | 6. Power enable pin |
| 3. Status LED | 7. Slider screws |
| 4. Power LED | |

Time and items required

The replacement procedure for the switch fabric module takes approximately 10 minutes. The following items are required for the switch fabric module replacement:

- ESD grounding strap
- #2 Phillips screwdriver
- Replacement switch fabric module

Removing a switch fabric module

You can continue to operate the device while a switch fabric module is being replaced.

NOTE

Review and follow [ESD precautions](#) on page 101 before removing a switch fabric module..

Complete the following steps to remove a switch fabric module. Refer to the illustration provided with the procedure.

1. Unscrew the power enable pin.
2. Loosen the two screws on the slider using the Phillips screwdriver if necessary.
3. Pull out the pin and move the slider all the way up, exposing the captive screw.
4. Unscrew the two captive screws using the Phillips screwdriver.

5. Open the ejectors by rotating them toward the center of the module face. Pull the switch fabric module out of the chassis using the ejectors.

FIGURE 58 Removal and replacement of the switch fabric module

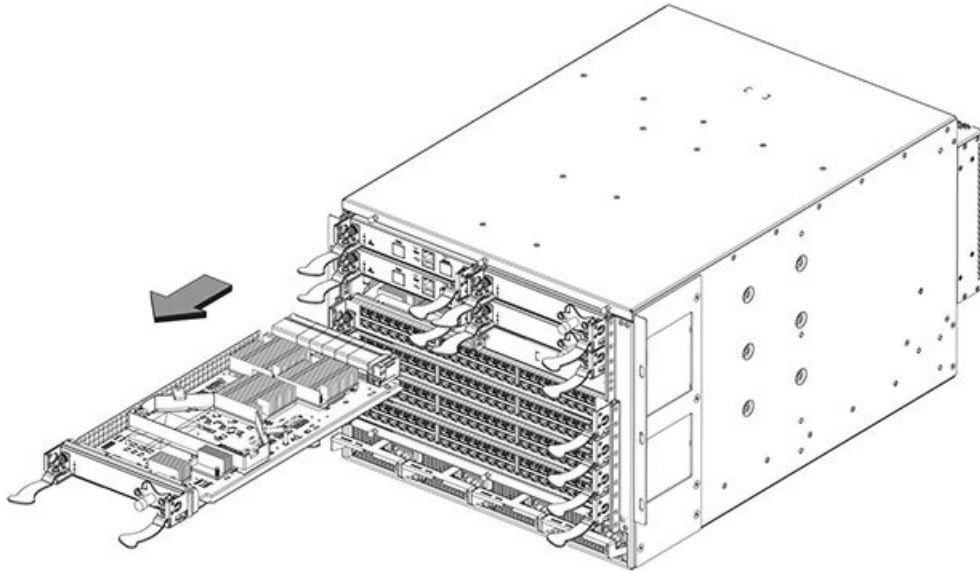

Replacing a switch fabric module

Complete the following steps to insert the switch fabric module . Refer to the illustration provided with the procedure.

NOTE

Review and follow [ESD precautions](#) on page 101 before removing a switch fabric module.

1. Unpack the new switch fabric module and remove it from the anti-static bag.
2. Inspect the module for damage.
3. Remove the protective caps from the backplane connectors.
4. Unscrew the power enable pin, pull it outward, and move the slider toward the center of the module face.
5. Open the ejectors on the new switch fabric module by rotating them toward the center of the module face. Orient the switch fabric module so that the ejectors are toward you.
6. Align the module pan with the guides in the slot. The first switch fabric module should be installed in slot S3.
7. Push the switch fabric module firmly into the slot.
8. Close the ejectors by rotating them away from the center of the switch fabric module . The levering action of the ejectors seats the module in the slot.

The Status LED comes on.

9. Tighten the captive screws using the Phillips screwdriver.
10. Pull out the power enable pin and move the slider all the way down.

11. Screw in the power enable pin.

The Power LED comes on.

Tighten the screws on the slider. The Status LED goes out when the switch fabric module is fully initialized.

12. Pack the faulty switch fabric module in the packaging provided with the new switch fabric module, and contact your supplier to determine the return procedure.

Power supply removal and replacement

Use this procedure to remove and replace a power supply.

NOTE

Depending on the module configuration of the chassis and the number of power supplies installed, the device may be able to continue operating during the replacement. Refer to The Technical Specifications to determine your power requirements. If insufficient power is present, the chassis will start powering down modules until the power demand can be met.



DANGER

This device might have more than one power cord. To reduce the risk of electric shock, disconnect all power cords before servicing.



DANGER

Remove both power cords before servicing.



DANGER

Disconnect the power cord from all power sources to completely remove power from the device.

Time and items required

The replacement procedure for each power supply takes less than 5 minutes. The following items are required for the power supply replacement:

- New power supply unit or filler panel.
- #1 Phillips screwdriver.
- #2 Phillips screwdriver.

Removing an AC power supply

To remove a power supply, complete the following steps. Refer to the illustration provided with the procedure.

1. Perform the appropriate following action based on whether the device is operating:
 - If the device is not operating during the replacement procedure, go to step 2.
 - If the device is operating and will continue to operate during the replacement, check the power LEDs to verify that the minimum number of power supplies is functioning. Refer to the Technical Specifications to check your power requirements.
2. Unlatch the power cord retainer clip.
3. Remove the power cord.
4. Loosen the captive screw.
5. Push down on the handle to eject the power supply.

6. Grasp the handle and pull, sliding the power supply from the chassis and supporting the power supply from beneath as you remove it.

FIGURE 59 Removal and replacement of the power supply

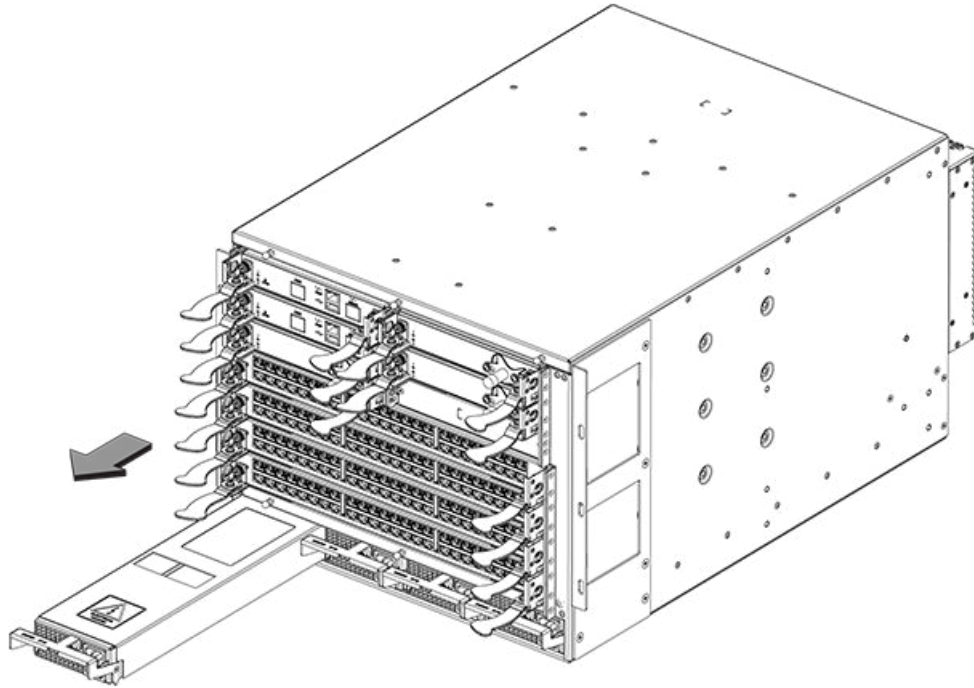

Replacing an AC power supply

To replace a power supply, complete the following steps. Refer to the illustration provided with the procedure.



DANGER

High Touch Current. Earth connection essential before connecting supply.



CAUTION

If you do not install a module or a power supply in a slot, you must keep the slot filler panel in place. If you run the chassis with an uncovered slot, the system will overheat.

1. Unpack the new power supply and remove it from the anti-static bag.
2. Inspect the power supply for damage.
3. Ensure that the handle of the replacement power supply is pushed down.
4. Insert the power supply into the slot.
5. Rotate the handle upward to fully seat the power supply.
6. Tighten the captive screw. Replace the power cord.
7. Latch the power cord retainer clip.
8. Verify that the power LED on the power supply displays a steady green light.

Removing a DC power supply

To remove a DC power supply, complete the following steps.

1. If the device is operating and will continue to operate during the replacement, check the power LEDs to verify that the minimum number of power supplies is functioning. Refer to the Technical Specifications to check your power requirements.
2. Disconnect the power supply from the power source.
3. Use a #1 Phillips screwdriver to remove the screw that secures the safety cover over the power lugs. Remove the safety cover.
4. Use a #2 Phillips screwdriver to unscrew the power lugs.
5. Loosen the captive screw underneath the latch handle on the power supply faceplate.
6. Push down on the handle to eject the power supply.
7. Grasp the handle and pull, sliding the power supply from the chassis and supporting the power supply from beneath as you remove it.

Replacing a DC power supply



CAUTION

If you do not install a module or a power supply in a slot, you must keep the slot filler panel in place. If you run the chassis with an uncovered slot, the system will overheat.

To replace a DC power supply, complete the following steps.

1. Unpack the new power supply and remove it from the anti-static bag.
2. Inspect the power supply for damage.
3. Use a #1 Phillips screwdriver to remove the screw that secures the safety cover over the power lugs. Remove the safety cover.
4. Ensure that the handle of the replacement power supply is rotated down.
5. Insert the power supply into the slot.
6. Rotate the handle upward to fully seat the power supply.
7. Tighten the captive screw.
8. Reconnect the power lugs to the power supply unit.

Connect the -48V wire to the negative terminal and the OV wire to the positive terminal.

NOTE

The DC return must be isolated from the device ground (DC-I) when making connections to the connections to the power supply.

9. Replace the safety cover.
10. Reattach the power cord to the power source.
11. Verify that the power LED on the power supply displays a steady green light.

NOTE

This equipment installation must meet NEC/CEC code requirements. Consult local authorities for regulations.

Fan removal and replacement

Use this procedure to remove and replace a fan.

NOTE

The device can continue operating during the fan replacement

Time and items required

The replacement procedure for each fan takes less than 5 minutes. The following items are required for the fan replacement:

- Replacement fan
- #2 Phillips screwdriver

Removing a fan

Complete the following steps to remove a fan from the chassis. Refer to the illustration provided with the procedure.

1. Before removing a fan, verify that the other fans are functioning properly. The power LEDs should be steady green.



DANGER

Be careful not to accidentally insert your fingers into the fan tray while removing it from the chassis. The fan may still be spinning at a high speed.

2. Use the screwdriver to loosen the four captive screws at the top and bottom of the fan.
3. Grasp the handle and pull, sliding the fan from the chassis and supporting the fan from beneath as you remove it.

FIGURE 60 Removal and replacement of the fan

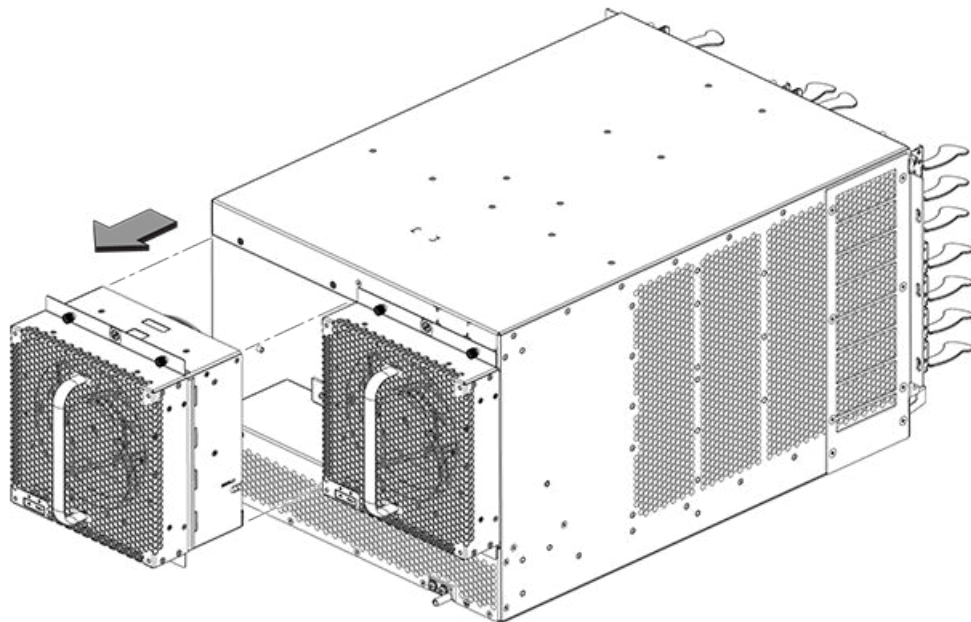

Replacing a fan

Complete the following steps to replace the fan in a chassis. Refer to the illustration provided in [Removing a fan](#) on page 116.

1. Orient the fan and slide it into the chassis, pushing firmly to ensure that it is seated.
2. Verify that the power LED displays a green light.
3. Use the screwdriver to tighten the four captive screws.

Air filter removal and replacement

You can remove and replace an air filter when it gets too clogged with dirt and dust to operate efficiently. You should perform regular physical inspections to determine how often to replace the air filter. Maintaining clean air filters ensures optimal airflow through the devices.

Based on the traffic and particulate levels of the installation location, the site operator should determine the appropriate replacement intervals for the air filter.

If the air filter were to become sufficiently blocked, the thermal policy of the device would notify the administrator of an environmental issue with the system.

If a site-specific interval cannot be determined by the site operator, the filter should be replaced on an interval of every 3 months.

The filters are single use and non-recyclable. They have a UL fire rating of FLAME RETARDANT, UL 94HF-1 UAF and PPI measurement of 25.

The chassis is shown in a four-post recessed-mount rack configuration, but the mounting of the air filter is the same for any rack mount. Refer to the following illustration.

FIGURE 61 Removal and replacement of the air filter

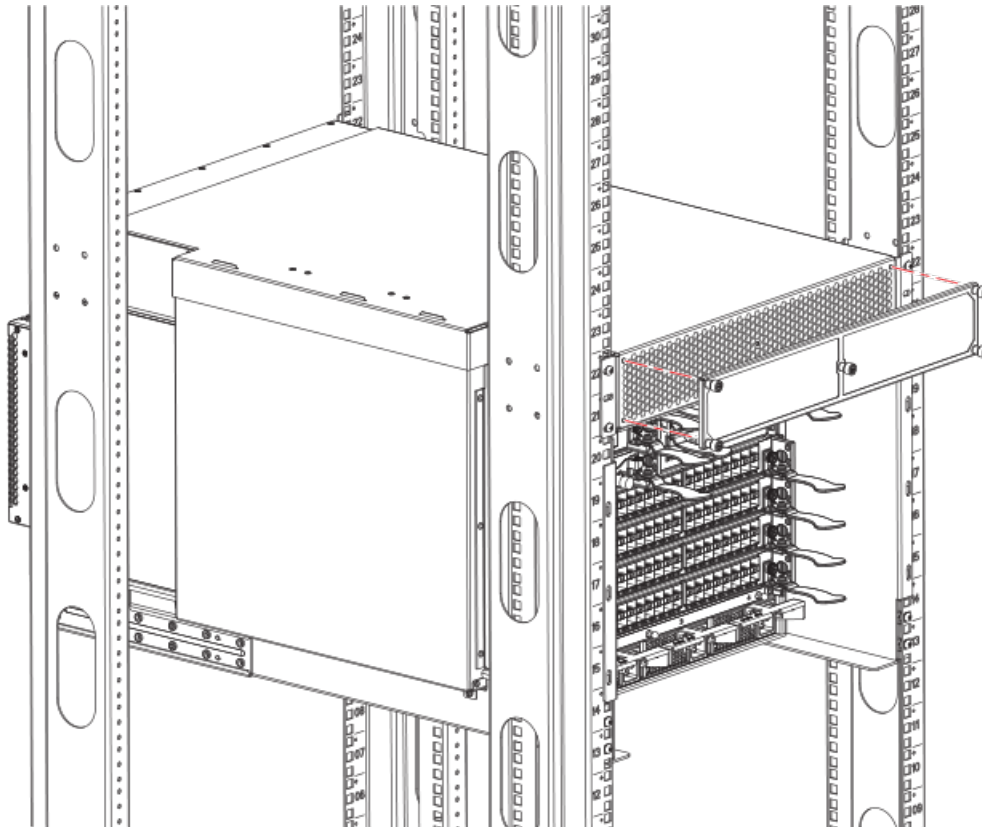

Time and items required

The replacement procedure for the air filter takes less than 5 minutes. Be sure to have the following items available:

- New air filter
- A #2 Phillips screwdriver

Removing an air filter

Complete the following steps to remove a front air filter from the chassis.

1. While holding the air filter in place, unscrew the four captive mounting screws using the #2 Phillips screwdriver.
2. Carefully remove the air filter from the chassis.

To avoid having captured particulates drawn into the chassis, remove the filter in a fashion that maintains the orientation of the filter relative to the system until the filter is 12 inches away from the intake.

Replacing an air filter

Complete the following steps to mount the new front air filter on the chassis.

1. Orient the new filter over the four mounting holes using the screws as guides.
Be sure the side marked BOTTOM is on the bottom.
2. Using the #2 Phillips screwdriver, initiate the threads, two turns per screw, until all four are started.
3. Tighten all four screws, one at a time.

Do not overtighten the screws as this will compromise the frame, admitting unfiltered air.

Module filler panel removal and replacement

Each removable module in the chassis (except the fans) has a matching filler panel that must be in place if no module is installed in a slot. This includes management modules, switch fabric modules, line cards, and power supplies. There are no filler panels for the fans because all fans must be installed on the chassis.



CAUTION

If you do not install a module or a power supply in a slot, you must keep the slot filler panel in place. If you run the chassis with an uncovered slot, the system will overheat.

Removing a filler panel

A filler panel should be removed only when being replaced with a new module or another filler panel. Any slot that is not occupied by a module should be occupied by a filler panel to ensure proper cooling of the chassis and protection from dust.



CAUTION

If you do not install a module or a power supply in a slot, you must keep the slot filler panel in place. If you run the chassis with an uncovered slot, the system will overheat.

Filler panels for the management module and switch fabric module are the same. The filler panel for the line card slot is similar, though larger. Both the management module and switch fabric module panels and line card panels have two release pins and sliders. The filler panel for the power supply slot is quite different, having only one release pin and slider.

Complete the following steps to remove a filler panel from the chassis.

1. Pull the release pin or pins out and simultaneously move the slider or sliders.
The entire face of the power supply filler panel is a slider and it moves upward to release the panel.
The sliders for the management module and switch fabric module and line card filler panels move toward the center of the panel to release it.
2. Pull the filler panel out of the chassis using the release pins.

Replacing a filler panel

Do not leave a slot empty. This will adversely affect cooling of the chassis.

**CAUTION**

If you do not install a module or a power supply in a slot, you must keep the slot filler panel in place. If you run the chassis with an uncovered slot, the system will overheat.

1. Orient the filler panel.

The management module and switch fabric module and line card filler panels must be aligned with the slot guides.

The power supply filler panels simply fit into the slots.

2. Slide the filler panel into the slot until it is firmly seated.

The power supply panel may slide too far into the slot. Insert it only until the facing matches the facing of the other power supplies or filler panels.

3. Move the sliders and release the release pins.

The release pins should retract completely.

Chassis ID card removal and replacement

Chassis ID (CID) cards cannot be removed or replaced by customers. If you experience a CID card failure, call Extreme Technical Support.

When an error is detected, you can run the CID Recovery Tool to pinpoint the problem and, in some cases, fix it. If the problem is determined to be in the critical seeprom portion of the card, no recovery is possible and you must contact Extreme Technical Support. If however, the problem is in the non-critical seeprom, it is possible that you can use the recovery tool to fix the problem.

To run the CID Recovery Tool, enter the following command in Privileged EXEC mode.

```
sw0# cidrecov
```

If the problem is in the critical seeprom, the output indicates that you should call Extreme Technical Support. If the problem is in the non-critical seeprom, the output describes the issue and the affected data and gives you several possible options for action.

For more detail concerning these options, refer to the "Using the Chassis ID (CID) Recovery Tool" chapter in the *Extreme Network OS Troubleshooting Guide* and the "cidrecov" topic in the *Extreme Network OS Command Reference*.

TABLE 18 Options for the CID Recovery Tool

Condition	Recovery Option
One non-critical seeprom is corrupted.	Tool displays the CID to be recovered and prompts to continue or abort.
Both non-critical seeproms are corrupted.	Tool displays both CIDs to be recovered with default data and prompts to continue or abort.
Neither non-critical seeprom is corrupted but there is a data mismatch.	Tool prompts for the CID to be recovered or to abort.
No corruption or mismatch is found.	Tool displays that there is nothing to be done and then exits on acknowledgment.

SFP transceiver removal and replacement

Use the following procedure to remove and replace an SFP or SFP+ transceiver.

**DANGER**

All fiber-optic interfaces use Class 1 lasers.

**DANGER***Laser Radiation. Do Not View Directly with Optical Instruments. Class 1M Laser Products.*

Time and items required

The replacement procedure for one transceiver takes less than 5 minutes. You should have the following items available:

- Replacement SFP or SFP+ transceiver
- Optical transceiver extraction tool

Most Extreme Networks devices and backbones come with an optical transceiver extraction tool (Figure 62) and holster. The extraction tool is designed to remove transceivers from modules where the space is limited.

FIGURE 62 Optical transceiver extraction tool

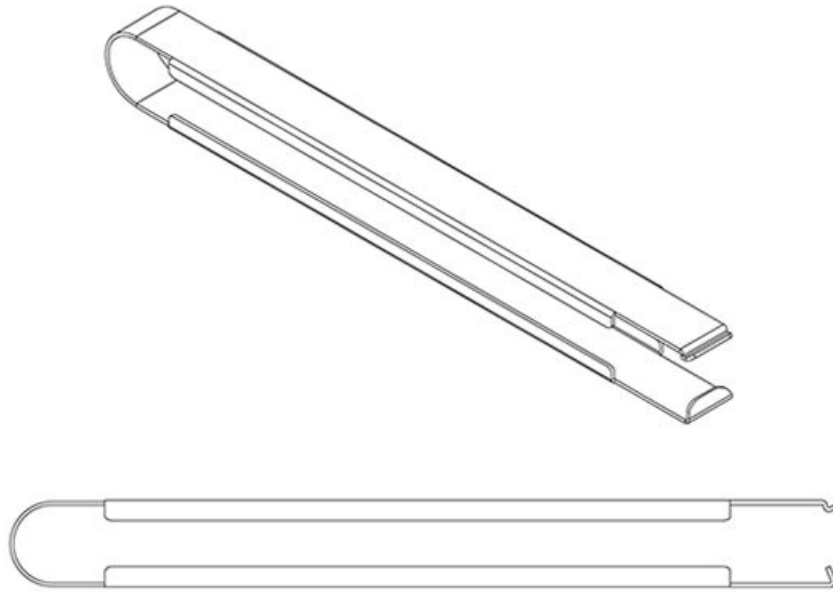

Removing a transceiver

For the following procedure refer to the illustration.

Complete the following steps to remove an SFP or SFP+ transceiver.

1. Remove any cables that are inserted into the transceiver. Use the extraction tool to open the cable latching mechanism.

- Using the hooked end of the tool, pull the bail (wire handle) away from its pivot point and out, sliding the transceiver out of the device or module.

FIGURE 63 Optical transceiver with bail open

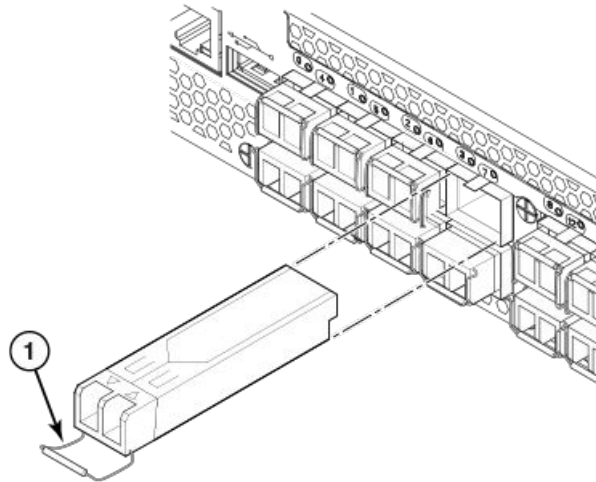

- SFP or SFP+ bail

Replacing a transceiver

Complete the following steps to replace an SFP or SFP+ transceiver. Refer to the illustration in [Removing a transceiver](#) on page 121.

- Making sure that the bail (wire handle) is in the unlocked or open position, position the optical transceiver so that the key is oriented correctly to the port. Insert the transceiver into the port until it is firmly seated and the latching mechanism clicks.
Transceivers are keyed so that they can only be inserted with the correct orientation. If a transceiver does not slide in easily, ensure that it is correctly oriented.
- Position a cable so that the key (the ridge on one side of the cable connector) is aligned with the slot in the transceiver. Insert the cable into the transceiver until the latching mechanism clicks.

Cables are keyed so that they can be inserted in only one way. If a cable does not slide in easily, ensure that it is correctly oriented.

QSFP transceiver removal and replacement

Use this procedure to remove and replace a QSFP transceiver. Because each 40 GbE QSFP transceiver consists of four 10 GbE ports, be aware that any problems with one port could affect all four ports in the quad.



DANGER
All fiber-optic interfaces use Class 1 lasers.



DANGER
Laser Radiation. Do Not View Directly with Optical Instruments. Class 1M Laser Products.

Removing a QSFP transceiver

Complete the following steps to remove a QSFP transceiver.

1. Remove the fiber-optic cable from the transceiver.
2. If your transceiver has an integrated pull tab, gently pull the transceiver from the port using the tab.
3. If your transceiver has a bail release, as shown in the following figure, complete the following steps.
 - a) Pivot the bail on the transceiver to the horizontal position.
 - b) Holding the transceiver by the bail, gently pull the transceiver out of the port.
4. Insert a protective plug into the transceiver and put it aside.

FIGURE 64 QSFP cable and transceiver with bail open

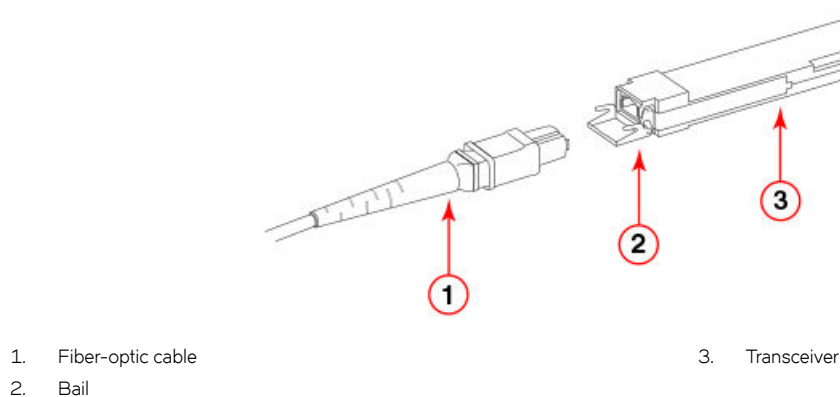

1. Fiber-optic cable
2. Bail

3. Transceiver

Replacing a QSFP transceiver

Complete the following steps to replace a QSFP transceiver.

1. Position the new QSFP transceiver so that the key is oriented correctly to the port.
2. Grasping the edges of the transceiver, gently push it into the port until it is firmly seated and the latching mechanism clicks. If your transceiver has a bail release, pull the bail up to lock the transceiver in place.

Transceivers are keyed so that they can only be inserted with the correct orientation. If a transceiver does not slide in easily, ensure that it is correctly oriented.

3. Remove the protective plug from the transceiver.
4. Position the cable so that the key (the ridge on one side of the cable connector) is aligned with the slot in the transceiver. Insert the cable into the transceiver until the latching mechanism clicks.

Cables are keyed so that they can be inserted in only one way. If a cable does not slide in easily, ensure that it is correctly oriented.

Cable routing table

The following table contains a 24-port template for a cable routing table. Make copies of the table to cover the total number of ports in the device.

TABLE 19 Cable routing table for the VDX 8770-4 (24 ports shown)

Slot/port		Cable labels		Connected device	Slot/port of device
Slot	Port	Switch end	Device end		
	1				
	2				
	3				
	4				
	5				
	6				
	7				
	8				
	9				
	10				
	11				
	12				
	13				
	14				
	15				
	16				
	17				
	18				
	19				
	20				
	21				
	22				
	23				
	24				

Air filter removal and replacement

You can remove and replace an air filter when it gets too clogged with dirt and dust to operate efficiently. You should perform regular physical inspections to determine how often to replace the air filter. Maintaining clean air filters ensures optimal airflow through the devices.

Based on the traffic and particulate levels of the installation location, the site operator should determine the appropriate replacement intervals for the air filter.

If the air filter were to become sufficiently blocked, the thermal policy of the device would notify the administrator of an environmental issue with the system.

If a site-specific interval cannot be determined by the site operator, the filter should be replaced on an interval of every 3 months.

The filters are single use and non-recyclable. They have a UL fire rating of FLAME RETARDANT, UL 94HF-1 UAF and PPI measurement of 25.

The chassis is shown in a four-post recessed-mount rack configuration, but the mounting of the air filter is the same for any rack mount. Refer to the following illustration.

FIGURE 65 Removal and replacement of the air filter

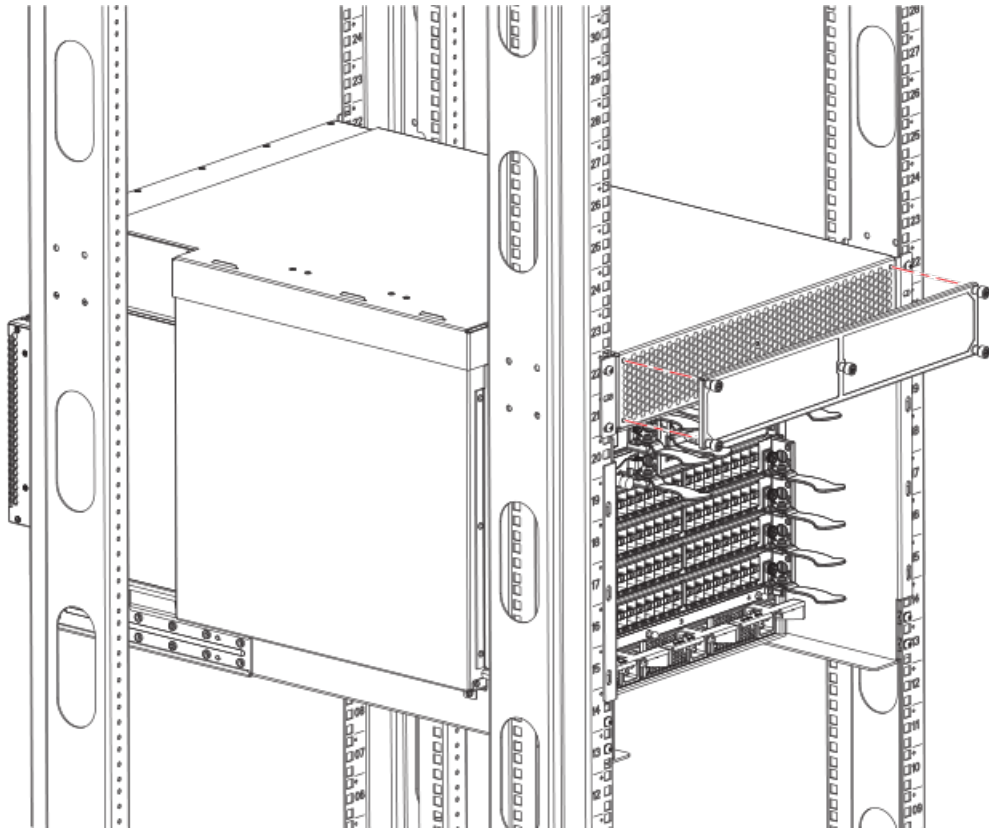

ExtremeSwitching VDX 8770 Technical Specifications

This document highlights the features and specifications for the VDX 8770-4 and VDX 8770-8 switches.

System specifications

System component	Description
Enclosure	VDX 8770-4 switch - 8U rack-mountable chassis; 10U with air duct rack kit; 19-inch EIA-compliant VDX 8770-8 switch - 14U rack-mountable chassis; 19-inch EIA-compliant
Power inlet	C19; power from port side
Power supplies	VDX 8770-4 switch - Up to four hot-swappable 3000 W AC or DC power supplies at 220 VAC or -48 VDC VDX 8770-8 switch - Up to eight hot-swappable 3000 W AC or DC power supplies at 220 VAC or -48 VDC
Fans	VDX 8770-4 switch - Two fans per chassis VDX 8770-8 switch - Four fans per chassis
Cooling	VDX 8770-4 switch - Side-to-back airflow with front-to-back duct converter option VDX 8770-8 switch - Front-to-back airflow
System architecture	Nonblocking shared memory, virtual output queued
System processors	1.5 GHz
Port-to-port latency	<4 microseconds for 64-byte packets

Ethernet

System component	Description
SFP GbE ports	VDX 8770-4 switch: <ul style="list-style-type: none">• 1 GbE: 48×1 GbE line card with 48 SFP/SFP-copper ports• 10 GbE: 48×10 GbE line card with 48 SFP+ ports• 40 GbE: 12×40 GbE line card with 12 40-GbE QSFP ports; 27×40 GbE line card with 27 40-GbE QSFP ports• 100 GbE: 6×100 GbE line card with 6 100-GbE CFP2 ports VDX 8770-8 switch: <ul style="list-style-type: none">• 1 GbE: 48×1 GbE line card with 48 SFP/SFP-copper ports• 10 GbE: 48×10 GbE line card with 48 SFP+ ports• 40 GbE: 27×40 GbE line card with 27 40-GbE QSFP ports• 100 GbEE: 6×100 GbE line card with 6 100-GbE CFP2 ports
Ethernet management port	RJ-45

LEDs

System component	Description
Line Card LEDs	<ul style="list-style-type: none"> • Power • Status • 10 GbE Port Status (48x10G-T line card) • 10 GbE Port Status (48x10 GbE line card) or 1 GbE Port Status (48x1 GbE line card) • 40 GbE QSFP Port Status (12x40 GbE or 27x40 GbE line card) in 40 GbE mode • 100 GbE Port Status (6x100 GbE line card)
Management Module LEDs	<ul style="list-style-type: none"> • Power • Status • Active • Ethernet Management link (upper left) • Ethernet Management link activity (upper right)
Switch Fabric Module LEDs	<ul style="list-style-type: none"> • Power • Status
Power Supply LEDs	<ul style="list-style-type: none"> • AC power input LED (AC OK) • DC power output LED (DC OK) • Alarm LED (ALM)
Fan LEDs	<ul style="list-style-type: none"> • OK • Fault

Other

System component	Description
Serial Cable	RJ-45 console cable
RJ-45 to DB9 adapter	RJ-45 to DB9 for console cable
RJ-45 connector	Uses an RJ-45 connector for the serial port

Weight and physical dimensions

"Fully loaded" VDX 8770-4 switch: 192-port configuration with four line cards, including two management modules, three switch fabric modules, two fans, four power supplies, and two cable management finger assemblies.

"Fully loaded" VDX 8770-8 switch: 384-port configuration with eight line cards, including two management modules, six switch fabric modules, four fans, eight power supplies, and one cable management comb.

Model	Height	Width	Depth	Weight (empty)	Weight (fully loaded)
VDX 8770-4 switch	34.7 cm	43.7 cm	61 cm	31.8 kg	86.2 kg
	13.7 inches	17.2 inches	24 inches	70 lb	190 lb
VDX 8770-4 switch with air duct rack kit	40 cm	43.7 cm	61 cm		
	15.7 inches	17.2 inches	24 inches		

Model	Height	Width	Depth	Weight (empty)	Weight (fully loaded)
VDX 8770-4 switch with fans	34.7 cm	43.7 cm	66 cm		
	13.7 inches	17.2 inches	26 inches		
VDX 8770-8 switch	66.2 cm	44 cm	66 cm	61.2 kg	165.6 kg
	26 inches	17.3 inches	26 inches	135 lb	365 lb

Card or module	Description	Height	Width	Thickness	Weight (no optics)
MM	Management module for chassis	19.83 cm	51.84 cm	3.78 cm	2.24 kg
		7.81 inches	20.41 inches	1.49 inches	4.96 lb
SFM	Switch fabric module	19.83 cm	52.62 cm	3.78 cm	2.6 kg
		7.81 inches	20.72 inches	1.49 inches	5.75 lb
48x10 GbE line card	Line card with 40 10 GbE transceivers	41.32 cm	51.20 cm	4.03 cm	5.8 kg
		16.27 inches	20.16 inches	1.59 inches	12.9 lb
48x10G-T line card	Line card with 48 fixed 10 GbE Base-T copper transceivers	41.32 cm	51.71 cm	4.03 cm	8.66 kg
		16.27 inches	20.36 inches	1.59 inches	19.1 lbs
48x1 GbE line card	Line card with 48 1 GbE transceivers	41.32 cm	51.2 cm	4.03 cm	5.8 kg
		16.27 inches	20.16 inches	1.59 inches	12.9 lb
12x40 GbE line card	Line card with 12 40 GbE transceivers	41.32 cm	51.76 cm	4.03 cm	5.39 kg
		16.27 inches	20.38 inches	1.59 inches	11.9 lb
6x100 GbE line card	Line card with 6 100 GbE transceivers	41.32 cm	51.76 cm	4.03 cm	9.61 kg
		16.27 inches	20.38 inches	1.59 inches	21.2 lb

Environmental requirements

Condition	Operational	Non-operational
Ambient temperature	0°C to 40°C (32°F to 104°F) outside switch	-25°C to 70°C (-13°F to 158°F) outside switch
Relative humidity (non-condensing)	5% to 90% at 40°C (104°F)	10% to 90% at 70°C (158°F)
Altitude (above sea level)	0 to 3000 m (10,000 feet)	0 to 12,000 m (40,000 feet)
Shock	20 G, 6 ms, half-sine wave	33 G, 11 ms, half-sine wave
Vibration	0.5 G, 5-500 Hz at 1.0 octave/minute	2.0 G, 5-500 Hz at 1.0 octave/minute
Airflow	Extreme VDX 8770-4 switch - Maximum: 1147 cmh (675 cfm) Extreme VDX 8770-8 switch - Maximum: 2124 cmh (1250 cfm)	N/A
Heat dissipation	Refer to values under "Power consumption (maximum configuration)".	N/A

Power supply specifications (per PSU)

Power supply model	Maximum output power rating (DC)	Input voltage	Input line frequency	Maximum input current	Input line protection	Maximum inrush current
XBR-ACPWR-3000	3000 W	200 - 240 VAC (nominal) 180 - 264 VAC (range)	50/60 Hz	16 A	Line & Neutral Fused	60 A peak for <10 ms, 10 ms - 150 ms <25 A peak, >150 ms <16 A
XBR-DCPWR-3000	3000 W	-48 VDC (nominal) -40 - 60 VDC (range)	N/A	90 A	Input fuse on -48 V input	≤70 A peak initial current surge or spike of <10 ms

Power consumption (typical configuration)

Configuration of the VDX 8770-4 switch chassis: 2 management modules, 3 switch fabric modules, 4 48x10G, 2 fan FRUs; blades-enabled; Optics/Traffic 50% line rate - random packets, fans at nominal speed.

Configuration of the VDX 8770-8 switch chassis: 2 management modules, 6 switch fabric modules, 8 48x10G, 4 fan FRUs; blades-enabled; Optics/Traffic 50% line rate - random packets, fans at nominal speed.

NOTE

A 100 VAC power supply is not supported on the VDX 8770-4 and Extreme VDX 8770-8 switches.

Model name	@100 VAC input	@200 VAC input	@-48 VDC input	Minimum number of power supplies	Notes
VDX 8770-4 switch	N/A	10 A 1971 W 6728 BTU/hr	41 A 1971 W 6728 BTU/hr	1	200 VAC amps, watts, and BTU/hr are calculated with 0.98 power factor and 2 PSUs
VDX 8770-8 switch	N/A	19 A 3838 W 13,101 BTU/hr	80 A 3838 W 13,101 BTU/h	2	200 VAC amps, watts, and BTU/hr are calculated with 0.98 power factor and 4 PSUs

Power consumption (maximum configuration)

Configuration of the VDX 8770-4 switch chassis: 2 management modules, 3 switch fabric modules, 4 48x10G, 2 fan FRUs; blades-enabled; Optics/Traffic full line rate - 64-byte packet, 40°C ambient fans at full speed.

Configuration of the VDX 8770-8 switch chassis: 2 management modules, 6 switch fabric modules, 8 48x10G, 4 fan FRUs; blades-enabled; Optics/Traffic full line rate - 64-byte packet, 40°C ambient fans at full speed.

NOTE

A 100 VAC power supply is not supported on the VDX 8770-4 and VDX 8770-8 switches.

Model name	@100 VAC input	@200 VAC input	@-48 VDC input	Minimum number of power supplies	Notes
VDX 8770-4 switch	N/A	16 A 3250 W 11092 BTU/hr	68 A 3250 W 11092 BTU/hr	1	200 VAC amps, watts, and BTU/hr are calculated with 0.99 power factor and 2 PSUs
VDX 8770-8 switch	N/A	32 A 6387 W 21799 BTU/hr	133 A 6387 W 21799 BTU/hr	2	200 VAC amps, watts, and BTU/hr are calculated with 0.99 power factor and 4 PSUs

Power consumption (modules)

Module name	Module description	Maximum power consumption
MM	Management Module	50 W
SFM	Switch Fabric Module	132 W
BR-VDX8770-48x1G-SFP-1	48x1 GbE, SFP module	460 W
BR-VDX8770-48x10G-SFP-1	48x10 GbE, SFP+ module	460 W
BR-VDX8770-12x40G-QSFP-1	12x40 GbE, QSFP+ module	440 W
BR-VDX8770-48x10G-T-1	48x10 GbE, RJ45 module	700 W
BR-VDX8770-27x40G-QSFP-1	27x40 GbE, QSFP+ module	580 W
BR-VDX8770-6x100G-CFP2-1	6x100 GbE, CFP2 module	700 W
XBR-FAN-FRU	Fan FRU for 4- and 8-slot chassis	268 W

Data port specifications (Ethernet)

Model	Port type	Number of ports	Description
VDX 8770-4 switch	1 GbE	192	Supports up to 192 1-GbE ports with four 48x1 GbE line cards
	10 GbE	192	Supports up to 192 10-GbE ports with four 48x10 GbE line cards
	40 GbE	48	Supports up to 48 40-GbE ports with four 12x40 GbE line cards
		108	Supports up to 108 40-GbE ports with four 27x40 GbE line cards
	100 GbE	24	Supports up to 24 100-GbE ports with four 6x100 GbE line cards
VDX 8770-8 switch	1 GbE	384	Supports up to 384 1-GbE ports with eight 48x1 GbE line cards
	10 GbE	384	Supports up to 384 10-GbE ports with eight 48x10 GbE line cards
	40 GbE	96	Supports up to 96 40-GbE ports with eight 12x40 GbE line cards
		216	Supports up to 216 40-GbE ports with eight 27x40 GbE line cards
	100 GbE	48	Supports up to 48 100-GbE ports with eight 6x100 GbE line cards

Serial port specifications (pinout RJ-45)

Pin	Signal	Description
1	Not supported	N/A
2	Not supported	N/A
3	RXD	Receive data
4	GND	Logic ground
5	Not supported	N/A
6	TXD	Transmit data
7	Not supported	N/A
8	Not supported	N/A

Serial port specifications (protocol)

Parameter	Value
Baud	9600
Data bits	8
Parity	None
Stop bits	1
Flow control	None

Memory specifications

Memory	Type	Size
Main memory	SDRAM	8 GB

Regulatory compliance (EMC)

- FCC Part 15, Subpart B (Class A)
- EN 55022 (CE mark) (Class A)
- EN 55024 (CE mark) (Immunity) for Information Technology Equipment
- ICES-003 (Canada) (Class A)
- AS/NZ 55022 (Australia) (Class A)
- VCCI (Japan) (Class A)
- EN 61000-3-2
- EN 61000-3-3
- EN 61000-6-1

Regulatory compliance (safety)

- CAN/CSA-C22.2 No. 60950/UL 60950
- EN 60825 Safety of Laser Products
- EN 60950/IEC 60950 Safety of Information Technology Equipment

Regulatory compliance (environmental)

- 2011/65/EU - Restriction of the use of certain hazardous substance in electrical and electronic equipment (EU RoHS).
- 2012/19/EU - Waste electrical and electronic equipment (EU WEEE).
- 94/62/EC - packaging and packaging waste (EU).
- 2006/66/EC - batteries and accumulators and waste batteries and accumulators (EU battery directive).
- 1907/2006 of the European Parliament and of the Council of 18 December 2006 concerning the Registration, Evaluation, Authorisation and Restriction of Chemicals (EU REACH).
- Section 1502 of the Dodd-Frank Wall Street Reform and Consumer Protection Act of 2010 - U.S. Conflict Minerals.
- 30/2011/TT-BCT - Vietnam circular.
- SJ/T 11363-2006 Requirements for Concentration Limits for Certain Hazardous Substances in EIPs (China).
- SJ/T 11364-2006 Marking for the Control of Pollution Caused by EIPs (China).

Regulatory Statements

• BSMI statement (Taiwan).....	135
• Canadian requirements.....	135
• CE statement.....	135
• China ROHS.....	136
• Federal Communications Commission (FCC) Notice.....	136
• KCC statement (Republic of Korea).....	136
• Japan (VCCI Class A).....	137
• Japan power cord	137

BSMI statement (Taiwan)

警告使用者：

此為甲類資訊技術設備，於居住環境中使用時，可能會造成射頻擾動，在此種情況下，使用者會被要求採取某些適當的對策。

Warning:

This is Class A product. In a domestic environment this product may cause radio interference in which case the user may be required to take adequate measures.

Canadian requirements

This Class A digital apparatus meets all requirements of the Canadian Interference-Causing Equipment Regulations, ICES-003 Class A.

Cet appareil numérique de la classe A est conforme à la norme NMB-003 du Canada.

CE statement

ATTENTION

This is a Class A product. In a domestic environment, this product might cause radio interference, and the user might be required to take corrective measures.

The standards compliance label on this device contains the CE mark which indicates that this system conforms to the provisions of the following European Council directives, laws, and standards:

- Electromagnetic Compatibility (EMC) Directive 2014/30/EU
- Low Voltage Directive (LVD) 2014/35/EU
- EN 55032/EN 55024 (European Immunity Requirements)
 - EN61000-3-2/JEIDA (European and Japanese Harmonics Spec)

- EN61000-3-3

China ROHS

Refer to the latest revision of the China ROHS document (P/N 53-1000428-xx) which ships with the product.

Federal Communications Commission (FCC) Notice

This device complies with Part 15 of the FCC rules. Operation is subject to the following two conditions: (1) this device may not cause harmful interference, and (2) this device must accept any interference received, including interference that may cause undesired operation.

NOTE

This equipment has been tested and found to comply with the limits for a class A digital device, pursuant to Part 15 of the FCC rules. These limits are designed to provide reasonable protection against harmful interference when the equipment is operated in a commercial environment. This equipment uses, generates, and can radiate radio frequency energy and if not installed in accordance with the operator's manual, may cause harmful interference to radio communications. Operation of this equipment in a residential area is likely to cause interference in which case the user will be required to correct the interference at his own expense.

WARNING: Changes or modifications made to this device which are not expressly approved by the party responsible for compliance could void the user's authority to operate the equipment.

KCC statement (Republic of Korea)

이 기기는 업무용 환경에서 사용할 목적으로 적합성평가를 받은 기기로서 가정용 환경에서 사용하는 경우 전파간섭의 우려가 있습니다.

Class A device (Broadcasting Communication Device for Office Use): This device obtained EMC registration for office use (Class A), and may be used in places other than home. Sellers and/or users need to take note of this.

Japan (VCCI Class A)



WARNING

This is a Class A product based on the standard of the VCCI Council. If this equipment is used in a domestic environment, radio interference may occur, in which case the user may be required to take corrective actions.

この装置は、クラスA情報技術装置です。この装置を家庭環境で使用すると電波妨害を引き起こすことがあります。この場合には使用者が適切な対策を講ずるよう要求されることがあります。

VCCI-A

Japan power cord



注意 - 添付の電源コードを他の装置や用途に使用しない

添付の電源コードは本装置に接続し、使用することを目的として設計され、その安全性が確認されているものです。決して他の装置や用途に使用しないでください。火災や感電の原因となる恐れがあります。

English translation of above statement

ATTENTION: Never use the power cord packed with your equipment for other products.

Cautions and Danger Notices

- Cautions.....139
- Danger Notices.....142

Cautions

A Caution statement alerts you to situations that can be potentially hazardous to you or cause damage to hardware, firmware, software, or data.

Ein Vorsichtinweis warnt Sie vor potenziellen Personengefahren oder Beschädigung der Hardware, Firmware, Software oder auch vor einem möglichen Datenverlust

Un message de mise en garde vous alerte sur des situations pouvant présenter un risque potentiel de dommages corporels ou de dommages matériels, logiciels ou de perte de données.

Un mensaje de precaución le alerta de situaciones que pueden resultar peligrosas para usted o causar daños en el hardware, el firmware, el software o los datos.

General cautions



CAUTION

Do not install the device in an environment where the operating ambient temperature might exceed 40°C (104°F).

VORSICHT	Das Gerät darf nicht in einer Umgebung mit einer Umgebungsbetriebstemperatur von über 40°C (104°F) installiert werden.
MISE EN GARDE	N'installez pas le dispositif dans un environnement où la température d'exploitation ambiante risque de dépasser 40°C (104°F).
PRECAUCIÓN	No instale el instrumento en un entorno en el que la temperatura ambiente de operación pueda exceder los 40°C (104°F).

Electrical cautions



CAUTION

All devices with DC power supplies are intended for installation in restricted access areas only. A restricted access area is a location where access can be gained only by trained service personnel through the use of a special tool, lock and key, or other means of security, and is controlled by the authority responsible for the location.

VORSICHT	Alle Geräte mit DC-Netzteil sind nur für die Installation in Bereichen mit beschränktem Zugang gedacht. Ein Bereich mit beschränktem Zugang ist ein Ort, zu dem nur ausgebildetes Wartungspersonal mit Spezialwerkzeug, Schloss und Schlüssel oder anderen Sicherheitsvorrichtungen Zugang hat. Dieser Zugang wird von für den Bereich zuständigen Personen überwacht.
MISE EN GARDE	Tous les équipements dotés de sources d'alimentation C.C. sont destinés à être installés uniquement dans des zones à accès réglementé. Une zone à accès réglementé est une zone dont l'accès n'est possible qu'au personnel de service qualifié utilisant un verrou, une clé ou un outil spécial, ou d'autres moyens de sécurité, et qui est contrôlée par les autorités responsables du site.
PRECAUCIÓN	Todos los dispositivos con fuentes de alimentación de corriente continua (CC) han sido diseñados únicamente para su instalación en áreas restringidas/ zonas de acceso restringido . Se entiende como área de acceso restringido un lugar al que solo puede acceder personal de servicio mediante el uso de una herramienta especial, llave y cerrojo u otro medio de seguridad similar, y que esté controlado por la autoridad responsable de esa ubicación.

**CAUTION**

For the NEBS-compliant installation of an Extreme Networks device, use a ground wire of at least 2 AWG. The ground wire should have an agency-approved crimped connector (provided with the device) attached to one end, with the other end attached to building ground. The connector must be crimped with the proper tool, allowing it to be connected to both ground screws on the enclosure. Before crimping the ground wire into the provided ground lug, ensure that the bare copper wire has been cleaned and antioxidant is applied to the bare wire. In addition, anti-rotation devices or lock washers must be used with all screw connections for the grounding wire.

VORSICHT	Zur NEBS-konformen Installation eines Extreme Networks Geräts muss zur Erdung ein Kabel der Stärke von mindestens 2 AWG verwendet werden. Das Erdungskabel muss an einem Ende mit einem zugelassenen Crimp-Anschluss (im Lieferumfang des Geräts) versehen sein und mit dem anderen Ende an die Gebäude-Erde angeschlossen werden. Der Anschluss muss mit einem geeigneten Werkzeug gecrimpt werden, damit er mit den beiden Erdungsschrauben auf dem Gehäuse verbunden werden kann. Bevor das Erdungskabel an die Erdungsöse angeschlossen wird, muss der blanke Kupferdraht gereinigt und mit einem Antioxidationsmittel behandelt werden. Außerdem müssen bei allen Schraubverbindungen des Erdungskabels Drehsicherungen oder Sicherungsscheiben verwendet werden.
MISE EN GARDE	Pour garantir la conformité de l'installation d'un dispositif Extreme Networks à la norme NEBS, utilisez un câble de mise à la terre d'au moins 2 AWG. Le câble de mise à la terre doit être muni d'une cosse sertie homologuée (fournie avec l'appareil) à une extrémité, l'autre extrémité étant reliée à la terre. La cosse doit être sertie avec l'outil adéquat, ce qui permet de la relier aux deux vis de mise à la terre du boîtier. Avant de sertir le câble de mise à la terre dans la cosse fournie, assurez-vous que le fil de cuivre dénudé a été nettoyé et qu'un antioxydant a été appliqué. De plus, des dispositifs antirotation ou des rondelles de frein doivent être utilisés avec tous les raccords vissés au câble de mise à la terre.
PRECAUCIÓN	Para que la instalación de un dispositivo sea conforme a la certificación NEBS, utilice un cable de conexión a tierra de calibre AWG 2 como mínimo. El cable de conexión a tierra debe disponer de un conector engarzado homologado (suministrado con el dispositivo) unido a un extremo de modo que el otro extremo se conecte a la toma de tierra. El conector se debe engarzar con la herramienta adecuada de forma que se pueda conectar a los dos tornillos de conexión a tierra del compartimento. Antes de engarzar el cable de conexión a tierra a la patilla de conexión a tierra proporcionada, asegúrese de limpiar y aplicar antioxidante al alambre pelado de cobre. Además, deben emplearse los seguros contra giro o las arandelas de sujeción en todas las uniones atornilladas del cable de toma de tierra.

**CAUTION**

Use a separate branch circuit for each power cord, which provides redundancy in case one of the circuits fails.

VORSICHT	Es empfiehlt sich die Installation eines separaten Stromkreiszweiges für jede Elektroschnur als Redundanz im Fall des Ausfalls eines Stromkreises.
MISE EN GARDE	Utilisez un circuit de dérivation différent pour chaque cordon d'alimentation ainsi, il y aura un circuit redondant en cas de panne d'un des circuits.
PRECAUCIÓN	Use un circuito derivado separado para cada cordón de alimentación, con lo que se proporcionará redundancia en caso de que uno de los circuitos falle.

**CAUTION**

For the DC input circuit to the system (3000W supply), make sure there is a 80 amp circuit breaker, minimum -48VDC, double pole, on the input lugs to the power supply. The input wiring for connection to the product should be copper wire, 2 AWG, marked VW-1, and rated minimum 90o C.

VORSICHT	Bei der Gleichstromeingangsschaltung zum System (3000W supply), muss sichergestellt werden, dass an den Eingangskabelschuhen zur Stromversorgung ein zweipoliger Schalter mit UL-Zulassung, 80 Ampere und mindestens -48 V Gleichstrom vorhanden ist. Die Eingangsleitung zum Anschluss an das Produkt sollte als Kupferdraht, 2 AWG, angegeben, als VW-1 gekennzeichnet und für mindestens 90 °C bemessen sein.
MISE EN GARDE	Pour le circuit d'alimentation en courant continu du système (3000W supply), vérifier la présence d'un disjoncteur bipolaire homologué de 80 A, minimum -48 Vcc, sur l'entrée de l'alimentation. Les câbles d'alimentation du produit doivent être des fils de cuivre homologués de section 33.6 mm ² (2 AWG), marqués VW-1 et testés à 90° C.
PRECAUCIÓN	Para el circuito de entrada de CC al sistema (3000W supply), verifique que existe un disyuntor catalogado por UL de 80 amperios, -48VCC como mínimo, bipolar, en las orejetas de entrada a la fuente de alimentación. El cableado de entrada para la conexión al producto deberá ser de cable de cobre catalogado, 2 AWG, marcado con VW-1, y tener una capacidad nominal mínima para 90°C.

**CAUTION**

Before plugging a cable into any port, be sure to discharge the voltage stored on the cable by touching the electrical contacts to ground surface.

VORSICHT	Bevor Sie ein Kabel in einen Anschluss einstecken, entladen Sie jegliche im Kabel vorhandene elektrische Spannung, indem Sie mit den elektrischen Kontakten eine geerdete Oberfläche berühren.
MISE EN GARDE	Avant de brancher un câble à un port, assurez-vous de décharger la tension du câble en reliant les contacts électriques à la terre.
PRECAUCIÓN	Antes de conectar un cable en cualquier puerto, asegúrese de descargar la tensión acumulada en el cable tocando la superficie de conexión a tierra con los contactos eléctricos.

**CAUTION**

Static electricity can damage the chassis and other electronic devices. To avoid damage, keep static-sensitive devices in their static-protective packages until you are ready to install them.

VORSICHT	Statische Elektrizität kann das System und andere elektronische Geräte beschädigen. Um Schäden zu vermeiden, entnehmen Sie elektrostatisch empfindliche Geräte erst aus deren antistatischer Schutzhülle, wenn Sie bereit für den Einbau sind.
MISE EN GARDE	L'électricité statique peut endommager le châssis et les autres appareils électroniques. Pour éviter tout dommage, conservez les appareils sensibles à l'électricité statique dans leur emballage protecteur tant qu'ils n'ont pas été installés.
PRECAUCIÓN	La electricidad estática puede dañar el chasis y otros dispositivos electrónicos. A fin de impedir que se produzcan daños, conserve los dispositivos susceptibles de dañarse con la electricidad estática dentro de los paquetes protectores hasta que esté listo para instalarlos.

**CAUTION**

If you do not install a module or a power supply in a slot, you must keep the slot filler panel in place. If you run the chassis with an uncovered slot, the system will overheat.

VORSICHT	Falls kein Modul oder Netzteil im Steckplatz installiert wird, muss die Steckplatztafel angebracht werden. Wenn ein Steckplatz nicht abgedeckt wird, läuft das System heiß.
MISE EN GARDE	Si vous n'installez pas de module ou de bloc d'alimentation dans un slot, vous devez laisser le panneau du slot en place. Si vous faites fonctionner le châssis avec un slot découvert, le système surchauffera.
PRECAUCIÓN	Si no instala un módulo o un fuente de alimentación en la ranura, deberá mantener el panel de ranuras en su lugar. Si pone en funcionamiento el chasis con una ranura descubierta, el sistema sufrirá sobrecalentamiento.

**CAUTION**

Use a separate branch circuit for each power cord, which provides redundancy in case one of the circuits fails.

VORSICHT	Es empfiehlt sich die Installation eines separaten Stromkreiszweiges für jede Elektroschnur als Redundanz im Fall des Ausfalls eines Stromkreises.
MISE EN GARDE	Utilisez un circuit de dérivation différent pour chaque cordon d'alimentation ainsi, il y aura un circuit redondant en cas de panne d'un des circuits.
PRECAUCIÓN	Use un circuito derivado separado para cada cordón de alimentación, con lo que se proporcionará redundancia en caso de que uno de los circuitos falle.

**CAUTION**

Before plugging a cable into any port, be sure to discharge the voltage stored on the cable by touching the electrical contacts to ground surface.

VORSICHT	Bevor Sie ein Kabel in einen Anschluss einstecken, entladen Sie jegliche im Kabel vorhandene elektrische Spannung, indem Sie mit den elektrischen Kontakten eine geerdete Oberfläche berühren.
MISE EN GARDE	Avant de brancher un câble à un port, assurez-vous de décharger la tension du câble en reliant les contacts électriques à la terre.

PRECAUCIÓN	Antes de conectar un cable en cualquier puerto, asegúrese de descargar la tensión acumulada en el cable tocando la superficie de conexión a tierra con los contactos eléctricos.
------------	--



CAUTION

Static electricity can damage the chassis and other electronic devices. To avoid damage, keep static-sensitive devices in their static-protective packages until you are ready to install them.

VORSICHT	Statische Elektrizität kann das System und andere elektronische Geräte beschädigen. Um Schäden zu vermeiden, entnehmen Sie elektrostatisch empfindliche Geräte erst aus deren antistatischer Schutzhülle, wenn Sie bereit für den Einbau sind.
MISE EN GARDE	L'électricité statique peut endommager le châssis et les autres appareils électroniques. Pour éviter tout dommage, conservez les appareils sensibles à l'électricité statique dans leur emballage protecteur tant qu'ils n'ont pas été installés.
PRECAUCIÓN	La electricidad estática puede dañar el chasis y otros dispositivos electrónicos. A fin de impedir que se produzcan daños, conserve los dispositivos susceptibles de dañarse con la electricidad estática dentro de los paquetes protectores hasta que esté listo para instalarlos.



CAUTION

If you do not install a module or a power supply in a slot, you must keep the slot filler panel in place. If you run the chassis with an uncovered slot, the system will overheat.

VORSICHT	Falls kein Modul oder Netzteil im Steckplatz installiert wird, muss die Steckplatztafel angebracht werden. Wenn ein Steckplatz nicht abgedeckt wird, läuft das System heiß.
MISE EN GARDE	Si vous n'installez pas de module ou de bloc d'alimentation dans un slot, vous devez laisser le panneau du slot en place. Si vous faites fonctionner le châssis avec un slot découvert, le système surchauffera.
PRECAUCIÓN	Si no instala un módulo o un fuente de alimentación en la ranura, deberá mantener el panel de ranuras en su lugar. Si pone en funcionamiento el chasis con una ranura descubierta, el sistema sufrirá sobrecalentamiento.

Danger Notices

A Danger statement indicates conditions or situations that can be potentially lethal or extremely hazardous to you. Safety labels are also attached directly to products to warn of these conditions or situations.

Ein Gefahrenhinweis warnt vor Bedingungen oder Situationen die tödlich sein können oder Sie extrem gefährden können.

Sicherheitsetiketten sind direkt auf den jeweiligen Produkten angebracht um vor diesen Bedingungen und Situationen zu warnen.

Un énoncé de danger indique des conditions ou des situations potentiellement mortelles ou extrêmement dangereuses. Des étiquettes de sécurité sont posées directement sur le produit et vous avertissent de ces conditions ou situations.

Una advertencia de peligro indica condiciones o situaciones que pueden resultar potencialmente letales o extremadamente peligrosas. También habrá etiquetas de seguridad pegadas directamente sobre los productos para advertir de estas condiciones o situaciones.

General dangers



DANGER

The procedures in this manual are for qualified service personnel.

GEFAHR	Die Vorgehensweisen in diesem Handbuch sind für qualifiziertes Servicepersonal bestimmt.
DANGER	Les procédures décrites dans ce manuel doivent être effectuées par un personnel de maintenance qualifié.
PELIGRO	Los procedimientos de este manual deben llevarlos a cabo técnicos cualificados.

**DANGER**

Be careful not to accidentally insert your fingers into the fan tray while removing it from the chassis. The fan may still be spinning at a high speed.

GEFAHR	Die Finger dürfen nicht versehentlich in das Ventilatorblech gesteckt werden, wenn dieses vom Gehäuse abgenommen wird. Der Ventilator kann sich unter Umständen noch mit hoher Geschwindigkeit drehen.
DANGER	Faites attention de ne pas insérer vos doigts accidentellement dans le boîtier du ventilateur lorsque vous le retirez du châssis. Il est possible que le ventilateur tourne encore à grande vitesse.
PELIGRO	Procure no insertar los dedos accidentalmente en la bandeja del ventilador cuando esté desmontando el chasis. El ventilador podría estar girando a gran velocidad.

Electrical dangers

**DANGER**

If the installation requires a different power cord than the one supplied with the device, make sure you use a power cord displaying the mark of the safety agency that defines the regulations for power cords in your country. The mark is your assurance that the power cord can be used safely with the device.

GEFAHR	Falls für die Installation ein anderes Stromkabel erforderlich ist (wenn das mit dem Gerät gelieferte Kabel nicht passt), müssen Sie sicherstellen, dass Sie ein Stromkabel mit dem Siegel einer Sicherheitsbehörde verwenden, die für die Zertifizierung von Stromkabeln in Ihrem Land zuständig ist. Das Siegel ist Ihre Garantie, dass das Stromkabel sicher mit Ihrem Gerät verwendet werden kann.
DANGER	Si l'installation nécessite un cordon d'alimentation autre que celui fourni avec le dispositif, assurez-vous d'utiliser un cordon d'alimentation portant la marque de l'organisation responsable de la sécurité qui définit les normes et réglementations pour les cordons d'alimentation dans votre pays. Cette marque vous assure que vous pouvez utiliser le cordon d'alimentation avec le dispositif en toute sécurité.
PELIGRO	Si la instalación requiere un cordón de corriente distinto al que se ha suministrado con el instrumento, verifique que usa un cordón de corriente que venga con la marca de la agencia de seguridad que defina las regulaciones para cordones de corriente en su país. Esta marca será su garantía de que el cordón de corriente puede ser utilizado con seguridad con el instrumento.

**DANGER**

Make sure that the power source circuits are properly grounded, then use the power cord supplied with the device to connect it to the power source.

GEFAHR	Stellen Sie sicher, dass die Stromkreise ordnungsgemäß geerdet sind. Benutzen Sie dann das mit dem Gerät gelieferte Stromkabel, um es an die Stromquelle anzuschließen.
DANGER	Vérifiez que les circuits de sources d'alimentation sont bien mis à la terre, puis utilisez le cordon d'alimentation fourni avec le dispositif pour le connecter à la source d'alimentation.
PELIGRO	Verifique que circuitos de la fuente de corriente están conectados a tierra correctamente; luego use el cordón de potencia suministrado con el instrumento para conectarlo a la fuente de corriente

**DANGER**

For safety reasons, the ESD wrist strap should contain a series 1 megaohm resistor.

GEFAHR	Aus Sicherheitsgründen sollte ein EGB-Armband zum Schutz von elektronischen gefährdeten Bauelementen mit einem 1 Megaohm-Reihenwiderstand ausgestattet sein.
DANGER	Pour des raisons de sécurité, la dragonne ESD doit contenir une résistance de série 1 méga ohm.
PELIGRO	Por razones de seguridad, la correa de muñeca ESD deberá contener un resistor en serie de 1 mega ohmio.



DANGER

This device might have more than one power cord. To reduce the risk of electric shock, disconnect all power cords before servicing.

GEFAHR	Dieses System ist möglicherweise mit mehr als einem Netzkabel ausgestattet. Trennen Sie stets die Verbindung aller Netzkabel, bevor Sie Wartungsarbeiten durchführen, um die Gefahr eines Stromschlags auszuschließen.
DANGER	Ce commutateur peut comporter plusieurs cordons d'alimentation. Pour réduire les risques de choc électrique, déconnectez tous les cordons d'alimentation avant d'effectuer l'entretien de l'appareil.
PELIGRO	Este conmutador podría tener más de un cable de alimentación. Para reducir el riesgo de sufrir una descarga eléctrica, desconecte todos los cables de alimentación antes de proceder con la reparación.



DANGER

Remove both power cords before servicing.

GEFAHR	Trennen Sie beide Netzkabel, bevor Sie Wartungsarbeiten durchführen.
DANGER	Retirez les deux cordons d'alimentation avant toute maintenance.
PELIGRO	Desconecte ambos cables de alimentación antes de realizar reparaciones.



DANGER

Disconnect the power cord from all power sources to completely remove power from the device.

GEFAHR	Ziehen Sie das Stromkabel aus allen Stromquellen, um sicherzustellen, dass dem Gerät kein Strom zugeführt wird.
DANGER	Débranchez le cordon d'alimentation de toutes les sources d'alimentation pour couper complètement l'alimentation du dispositif.
PELIGRO	Para desconectar completamente la corriente del instrumento, desconecte el cordón de corriente de todas las fuentes de corriente.



DANGER

High Touch Current. Earth connection essential before connecting supply.

GEFAHR	Hoher Ableitstrom. Vor Anschluss ans Netz Schutzerdung herstellen.
DANGER	Courant de fuite élevé. Mise à la terre obligatoire avant la connexion de l'alimentation.
PELIGRO	Alta tensión al tacto. La conexión a tierra es esencial antes de conectar la alimentación.

Dangers related to equipment weight



DANGER

Make sure the rack housing the device is adequately secured to prevent it from becoming unstable or falling over.

GEFAHR	Stellen Sie sicher, dass das Gestell für die Unterbringung des Geräts auf angemessene Weise gesichert ist, so dass das Gestell oder der Schrank nicht wackeln oder umfallen kann.
DANGER	Vérifiez que le bâti abritant le dispositif est bien fixé afin qu'il ne devienne pas instable ou qu'il ne risque pas de tomber.
PELIGRO	Verifique que el bastidor que alberga el instrumento está asegurado correctamente para evitar que pueda hacerse inestable o que caiga.

**DANGER**

A fully populated ExtremeSwitching VDX 8770-8 weighs approximately 165.56 kg (365 lb) and requires a hydraulic or assisted lift to install it.

GEFAHR	Ein vollständig bestückter ExtremeSwitching VDX 8770-8 wiegt etwa 165.56 kg und erfordert zur Installation eine hydraulische oder Servo-Hebevorrichtung.
DANGER	Un commutateur ExtremeSwitching VDX 8770-8 complet pèse environ 165.56 kg et requiert un dispositif de levage hydraulique ou électrique pour l'installation.
PELIGRO	Un ExtremeSwitching VDX 8770-8 con la configuración completa pesa aproximadamente 165.56 kg (365 libras) y requiere un elevador hidráulico o asistido para realizar su instalación.

**DANGER**

Use safe lifting practices when moving the product.

GEFAHR	Beim Bewegen des Produktes ist auf eine sichere Hubtechnik zu achten.
DANGER	Utiliser des techniques de levage sûres pour déplacer le produit.
PELIGRO	Tenga mucho cuidado al levantar el producto para moverlo

Laser dangers

**DANGER**

All fiber-optic interfaces use Class 1 lasers.

GEFAHR	Alle Glasfaser-Schnittstellen verwenden Laser der Klasse 1.
DANGER	Toutes les interfaces en fibre optique utilisent des lasers de classe 1.
PELIGRO	Todas las interfaces de fibra óptica utilizan láser de clase 1.

**DANGER**

Laser Radiation. Do Not View Directly with Optical Instruments. Class 1M Laser Products.

GEFAHR	Laserstrahlung! Schauen Sie nicht direkt mit optischen Instrumenten in den Laserstrahl herein. Klasse 1M Laserprodukte.
DANGER	Rayonnement de laser. Ne regardez pas directement avec des instruments optiques. Produits de laser de classe 1M.
PELIGRO	Radiación de Laser. No vea directamente con Instrumentos Ópticos. Clase 1M de Productos de Laser.
警告	レーザー放射 光学器具で直接ビームを見ないこと クラス1 M レーザ製品