



ExtremeRouting SLX 9640 Hardware Installation Guide

9036362-00 Rev AD
March 2022



Copyright © 2021 Extreme Networks, Inc. All rights reserved.

Legal Notice

Extreme Networks, Inc. reserves the right to make changes in specifications and other information contained in this document and its website without prior notice. The reader should in all cases consult representatives of Extreme Networks to determine whether any such changes have been made.

The hardware, firmware, software or any specifications described or referred to in this document are subject to change without notice.

Trademarks

Extreme Networks and the Extreme Networks logo are trademarks or registered trademarks of Extreme Networks, Inc. in the United States and/or other countries.

All other names (including any product names) mentioned in this document are the property of their respective owners and may be trademarks or registered trademarks of their respective companies/owners.

For additional information on Extreme Networks trademarks, please see:

www.extremenetworks.com/company/legal/trademarks

Open Source Declarations

Some software files have been licensed under certain open source or third-party licenses. End-user license agreements and open source declarations can be found at:

www.extremenetworks.com/support/policies/software-licensing



Table of Contents

Preface.....	vi
Text Conventions.....	vi
Documentation and Training.....	viii
Getting Help.....	viii
Subscribe to Service Notifications.....	viii
Providing Feedback.....	ix
About this Document.....	10
Supported hardware and software.....	10
What is new in this document.....	12
Device Overview.....	13
ExtremeRouting SLX 9640 Product Introduction.....	13
Hardware features.....	13
Port-side view of the SLX 9640 Switch Router	14
Nonport-side view of the SLX 9640 Switch Router	15
Device management options.....	16
Preparing for the Installation.....	17
Safety precautions.....	17
General precautions.....	17
ESD precautions.....	18
Power precautions.....	19
Lifting precautions.....	19
Laser precautions.....	20
Facility requirements.....	20
Quick installation checklist.....	20
Shipping carton contents.....	21
Mounting the Device.....	22
Mounting options.....	22
Mounting precautions.....	22
Standalone installation.....	23
Installing the device in a rack.....	23
Four-post rack mount kit installation (XBR-R000297).....	24
Time and items required.....	24
Parts list.....	24
Flush-front mounting.....	25
Installing the Universal Two-Post Rack Kit (XEN-R000294).....	28
Installation requirements.....	29
Time and items required.....	29
Parts list	29
Flush-front mounting.....	30
Mid-mounting.....	34

Installing the Universal Four-Post Rack Kit (XEN-R000296).....	38
Installation requirements.....	40
Time and items required.....	40
Parts list.....	40
Flush-front mounting.....	42
Flush-rear (recessed) mounting.....	47
Initial Setup and Verification.....	54
Initial setup and configuration checklist.....	54
Items required.....	55
Providing power to the device.....	56
Establishing a serial connection	56
Configuring a static IP address.....	58
Establishing an Ethernet connection.....	59
Customizing the chassis and host names.....	60
Configuring the DNS service.....	61
Setting the date and time.....	61
Verifying correct operation.....	61
Backing up the configuration.....	62
Installing cable management kit.....	62
Transceivers and Cables.....	63
Supported transceivers and cables.....	63
Time and items required.....	63
Precautions specific to transceivers and cables.....	64
Cleaning the fiber-optic connectors.....	64
Managing cables.....	64
Installing an SFP+ transceiver.....	65
Replacing an SFP+ transceiver.....	67
Installing a QSFP28 transceiver.....	68
Replacing a QSFP28 transceiver.....	70
Breakout cables.....	71
Verifying transceiver operation.....	72
Monitoring the Device.....	73
Monitoring Overview.....	73
LED activity interpretation.....	73
LED indicators	74
Power Supplies.....	77
Power supply overview.....	77
Precautions specific to power supplies.....	79
Identifying the airflow direction.....	80
Time and items required.....	80
Replacing a power supply.....	80
Inserting a new AC power supply	81
Inserting a new DC power supply.....	82
Grounding the SLX 9640 device.....	85
Fan Assemblies.....	87
Fan assembly overview.....	87
Precautions specific to fan assemblies.....	88

Identifying the airflow direction.....	89
Times and items required.....	89
Replacing a fan assembly.....	89
Inserting a new fan assembly.....	90
ExtremeRouting SLX 9640 Technical Specifications.....	92
System specifications.....	92
Data port specifications (Ethernet).....	92
LEDs.....	93
Other.....	93
Weight and physical dimensions.....	93
Environmental requirements.....	93
Power supply specifications (per PSU).....	94
Power consumption (typical configuration).....	94
Power consumption (maximum configuration).....	95
Data port specifications (Ethernet).....	95
Serial port specifications (pinout RJ-45).....	95
Serial port specifications (pinout - mini-USB).....	95
Serial port specifications (protocol).....	96
Memory specifications	96
Regulatory compliance (EMC).....	96
Regulatory compliance (safety).....	97
Regulatory compliance (environmental).....	97
Regulatory Statements.....	98
CE statement.....	98
China ROHS.....	98
BSMI statement (Taiwan).....	99
Canadian requirements.....	99
China CCC statement.....	100
Europe and Australia (CISPR 32 Class A Warning).....	100
FCC warning (US only).....	100
Germany statement.....	101
KCC statement (Republic of Korea).....	101
VCCI statement.....	101
Japan power cord	102
Cautions and Danger Notices.....	103
Cautions.....	103
General cautions.....	103
Danger Notices.....	109
General dangers.....	109



Preface

This section describes the text conventions used in this document, where you can find additional information, and how you can provide feedback to us.

Text Conventions

Unless otherwise noted, information in this document applies to all supported environments for the products in question. Exceptions, like command keywords associated with a specific software version, are identified in the text.

When a feature, function, or operation pertains to a specific hardware product, the product name is used. When features, functions, and operations are the same across an entire product family, such as ExtremeSwitching switches or SLX routers, the product is referred to as *the switch* or *the router*.

Table 1: Notes and warnings



Icon	Notice type	Alerts you to...
	Tip	Helpful tips and notices for using the product.
	Note	Useful information or instructions.
	Important	Important features or instructions.

Table 1: Notes and warnings (continued)



Icon	Notice type	Alerts you to...
	Caution	Risk of personal injury, system damage, or loss of data.
	Warning	Risk of severe personal injury.

Table 2: Text

Convention	Description
<code>screen displays</code>	This typeface indicates command syntax, or represents information as it appears on the screen.
The words <i>enter</i> and <i>type</i>	When you see the word <i>enter</i> in this guide, you must type something, and then press the Return or Enter key. Do not press the Return or Enter key when an instruction simply says <i>type</i> .
Key names	Key names are written in boldface, for example Ctrl or Esc . If you must press two or more keys simultaneously, the key names are linked with a plus sign (+). Example: Press Ctrl+Alt+Del
<i>Words in italicized type</i>	Italics emphasize a point or denote new terms at the place where they are defined in the text. Italics are also used when referring to publication titles.
NEW!	New information. In a PDF, this is searchable text.

Table 3: Command syntax

Convention	Description
bold text	Bold text indicates command names, keywords, and command options.
<i>italic</i> text	Italic text indicates variable content.
[]	Syntax components displayed within square brackets are optional. Default responses to system prompts are enclosed in square brackets.
{ x y z }	A choice of required parameters is enclosed in curly brackets separated by vertical bars. You must select one of the options.
x y	A vertical bar separates mutually exclusive elements.
< >	Nonprinting characters, such as passwords, are enclosed in angle brackets.
...	Repeat the previous element, for example, <i>member</i> [<i>member</i> . . .].
\	In command examples, the backslash indicates a “soft” line break. When a backslash separates two lines of a command input, enter the entire command at the prompt without the backslash.

Documentation and Training

Find Extreme Networks product information at the following locations:

[Current Product Documentation](#)

[Release Notes](#)

[Hardware/software compatibility matrices](#) for Campus and Edge products

[Supported transceivers and cables](#) for Data Center products

[Other resources](#), like white papers, data sheets, and case studies

Extreme Networks offers product training courses, both online and in person, as well as specialized certifications. For details, visit www.extremenetworks.com/education/.

Getting Help

If you require assistance, contact Extreme Networks using one of the following methods:

Extreme Portal

Search the GTAC (Global Technical Assistance Center) knowledge base; manage support cases and service contracts; download software; and obtain product licensing, training, and certifications.

The Hub

A forum for Extreme Networks customers to connect with one another, answer questions, and share ideas and feedback. This community is monitored by Extreme Networks employees, but is not intended to replace specific guidance from GTAC.

Call GTAC

For immediate support: (800) 998 2408 (toll-free in U.S. and Canada) or 1 (408) 579 2826. For the support phone number in your country, visit: www.extremenetworks.com/support/contact

Before contacting Extreme Networks for technical support, have the following information ready:

- Your Extreme Networks service contract number, or serial numbers for all involved Extreme Networks products
- A description of the failure
- A description of any actions already taken to resolve the problem
- A description of your network environment (such as layout, cable type, other relevant environmental information)
- Network load at the time of trouble (if known)
- The device history (for example, if you have returned the device before, or if this is a recurring problem)
- Any related RMA (Return Material Authorization) numbers

Subscribe to Service Notifications

You can subscribe to email notifications for product and software release announcements, Vulnerability Notices, and Service Notifications.

1. Go to www.extremenetworks.com/support/service-notification-form.
2. Complete the form (all fields are required).

3. Select the products for which you would like to receive notifications.

**Note**

You can modify your product selections or unsubscribe at any time.

4. Select **Submit**.

Providing Feedback

The Information Development team at Extreme Networks has made every effort to ensure the accuracy and completeness of this document. We are always striving to improve our documentation and help you work better, so we want to hear from you. We welcome all feedback, but we especially want to know about:

- Content errors, or confusing or conflicting information.
- Improvements that would help you find relevant information in the document.
- Broken links or usability issues.

If you would like to provide feedback, you can do so in three ways:

- In a web browser, select the feedback icon and complete the online feedback form.
- Access the feedback form at <https://www.extremenetworks.com/documentation-feedback/>.
- Email us at documentation@extremenetworks.com.

Provide the publication title, part number, and as much detail as possible, including the topic heading and page number if applicable, as well as your suggestions for improvement.



About this Document

[Supported hardware and software on page 10](#)

[What is new in this document on page 12](#)

Supported hardware and software

The following table describes the ExtremeRouting SLX 9640 device Models .

Table 4: SLX 9640 Router Models

Part number	Description	Introduced OS	Currently supported
EN-SLX-9640-24S	Base unit with 24 1G/10G SFP+ ports, 4 10Gb/25Gb/40Gb/50Gb/100Gb capable QSFP28 ports, 2 unpopulated power supply slots, 6 unpopulated fan slots.	SLX-OS 18r.2.00	Yes
EN-SLX-9640-24S-AC-F	Base unit with 24 1G/10G SFP+ ports, 4 10Gb/25Gb/40Gb/50Gb/100Gb capable QSFP28 ports, 1 AC power supply, 6 fan modules, front-to-back airflow.	SLX-OS 18r.2.00	Yes
EN-SLX-9640-24S-12C	Base unit with 24 1G/10G SFP+ ports, 12 10Gb/25Gb/40Gb/50Gb/100Gb capable QSFP28 ports, 2 unpopulated power supply slots, 6 unpopulated fan slots.	SLX-OS 18r.2.00	Yes
EN-SLX-9640-24S-12C-AC-F	Base unit with 24 1G/10G SFP+ ports, 12 10Gb/25Gb/40Gb/50Gb/100Gb capable QSFP28 ports, 1 AC power supply, 6 fan modules, front-to-back airflow.	SLX-OS 18r.2.00	Yes

The following table describes the SLX 9640 Router Upgrade Licenses.

Table 5: ExtremeRouting SLX 9640 Upgrade Software Licenses

Part number	Description	Introduced OS	Currently supported
EN-SLX-9640-4C-POD-P	Ports on Demand to enable 4x100 GbE/40 GbE ports (for ExtremeRouting 9640-24S)	SLX-OS 18r.2.00	Yes
EN-SLX-9640-ADV-LIC-P	Advanced Feature License for MPLS, BGP-EVPN, CE2.0, NSX, Optiscale Internet Routing (for ExtremeRouting SLX 9640-24S and SLX 9640-24S-12C)	SLX-OS 18r.2.00	Yes

The following table list the SLX 9640 supported power supplies FRU.

Table 6: Supported SLX 9640 Power Supplies

Part number	Description	Introduced OS	Currently supported
XBR-ACPWR-650-F	SLX Fixed AC 650W Power Supply Front to Back airflow. Power cords not included.	SLX-OS 18r.2.00	Yes
XBR-ACPWR-650-R	SLX Fixed AC 650W Power Supply Back to Front airflow. Power cords not included.	SLX-OS 18r.2.00	Yes
XBR-DCPWR-650-F	SLX Fixed DC 650W Power Supply Front to Back airflow. Power cords not included.	SLX-OS 18r.2.00	Yes
XBR-DCPWR-650-R	SLX Fixed DC 650W Power Supply Back to Front airflow. Power cords not included.	SLX-OS 18r.2.00	Yes

The following table list the SLX 9640 power specifications.

Table 7: Supported SLX 9640 Power Specifications

Part number	Description	Introduced OS	Currently supported
All Models	AC Input: 100-240VAC, 450 W max. 50/60 Hz for each PSU	SLX-OS 18r.2.00	Yes
	DC Input: -48 to -60 VDC, 450 W max for each PSU		

The following table list the SLX 9640 supported Fan assemblies.

Table 8: Supported SLX 9640 Fan Assemblies for all models

Part number	Description	Introduced OS	Currently supported
XEN-SLX9640-FAN-F	SLX 9640 FAN Front to Back airflow	SLX-OS 18r.2.00	Yes
XEN-SLX9640-FAN-R	SLX 9640 FAN Back to Front airflow	SLX-OS 18r.2.00	Yes

The following table list the SLX 9640 Router supported Rack Mount Kit.

**Note**

XEN-R000296 and XEN-R000294 can also be used with SLX fixed models, however, the box includes XBR-R000297 at shipment.

Table 9: Supported SLX 9640 Switch Router Rack Mount Kit

Part number	Description
XEN-R000294	Legacy NEBS Compliant 2-post rack mount kit
XEN-R000296	Legacy NEBS Compliant 4-post rack mount kit
XBR-R000297	SLX fixed rack mount kit, 2-post/4-post, mid/flush mount compatible

What is new in this document

This is a new document.



Device Overview

[ExtremeRouting SLX 9640 Product Introduction on page 13](#)

[Hardware features on page 13](#)

[Port-side view of the SLX 9640 Switch Router on page 14](#)

[Nonport-side view of the SLX 9640 Switch Router on page 15](#)

[Device management options on page 16](#)

ExtremeRouting SLX 9640 Product Introduction

The SLX 9640 product is a high-density, purpose-built switch router designed for high-performance enterprise and cloud data centers primarily for network infrastructure category.

The SLX 9640 device can support a range of interface speeds, including 1Gb, 10Gb SFP+ ports and 10Gb, 25 Gb, 40 Gb, 50Gb and 100Gb QSFP28 ports, all in a compact 1RU from factor.

Hardware features

Table 10: ExtremeRouting SLX 9640 Device Features

SLX 9640 Device Features	Description
Maximum 100 GbE/40 GbE ports	12*
Maximum 10 GbE/1 GbE, 100Meg ports	24
Switch fabric capacity (data rate, full duplex)	900 Gpbs
Forwarding capacity (data rate, full duplex)	810 Mpps
Airflow	Front to back or back to front (orderable option)
Fan module slots	6 Fan FRU in (5 + 1) redundancy configuration
Maximum AC power supply rating	650 W
Power supply module slots	2 x 650 W AC/DC PSU in (1+1) redundancy configuration
Height	1.69 in/4.3 cm
Width	17.26 in/43.85 cm
Depth chassis only without cable management or fan handles	18.11 in/46 cm

Table 10: ExtremeRouting SLX 9640 Device Features (continued)

SLX 9640 Device Features	Description
Port type	100 GbE QSFP-28, 40 GbE QSFP+, 10 GbE SFP+, 1 GbE SFP+
Packet buffers per switch	6 GB

* Software upgrade licenses are available for the ExtremeRouting SLX 9640-24S for Ports on Demand (PoD) to enable 100 GbE/40 GbE ports.

The following shows the front view of the SLX 9640 Router.

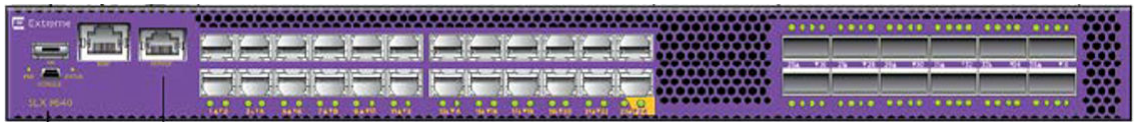

Figure 1: SLX 9640 Router front view

The following illustration shows the rear-view of the SLX 9640 Router.

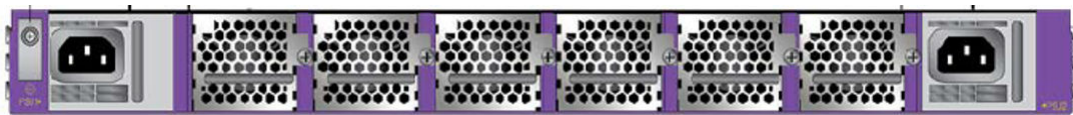
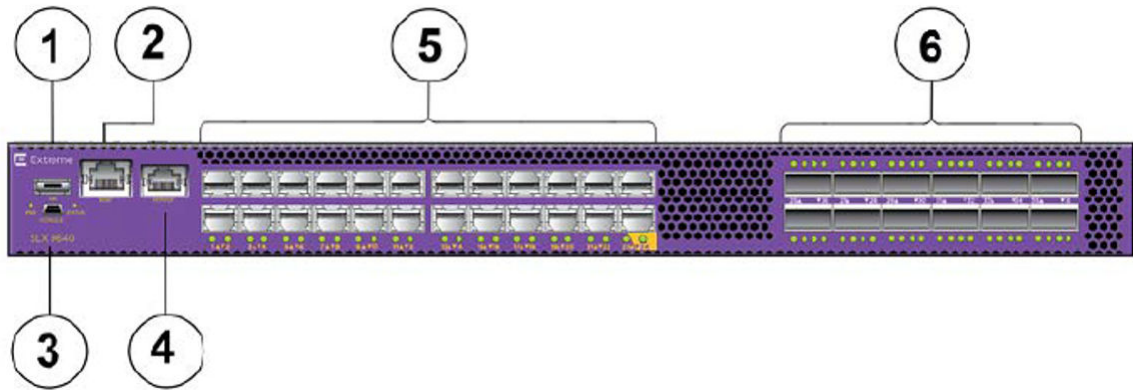

Figure 2: SLX 9640 Router rear view with power supply and fan assemblies

For more device details, refer to [ExtremeRouting SLX 9640 Technical Specifications](#) on page 92.

Port-side view of the SLX 9640 Switch Router

The following illustration shows the port-side view of the SLX 9640 Switch Router.



1. USB port
2. 1GbE Ethernet Service port
3. Console port (mini-USB)
4. 10GbE Ethernet service port
5. 1G/10G SFP+ ports (24x)
6. 10Gb/25Gb/40Gb/50Gb/100Gb capable QSFP28 ports (12x)

Figure 3: Port-side view of the SLX 9640 Switch Router

The Port numbering scheme is from top to bottom, and left to right as shown in the illustration below:

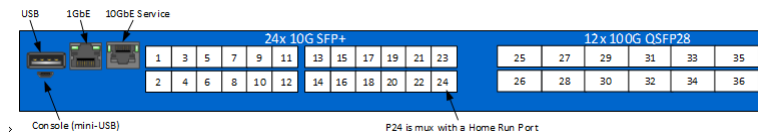

There are 24 SFP+ ports numbered from P1 to P24. Port 24 is multiplexed with Homerun port from the CPU. The port speed is 10GE/1GE.

There are 12 QSFP28 ports numbered from P25 to P36. The port speeds for the QSFP28 ports are as follows:

1. 10Gb
2. 25Gb
3. 40Gb
4. 50Gb
5. 100Gb

Nonport-side view of the SLX 9640 Switch Router

The following illustration shows the rear-view or nonport-side of the SLX 9640 Switch Router.

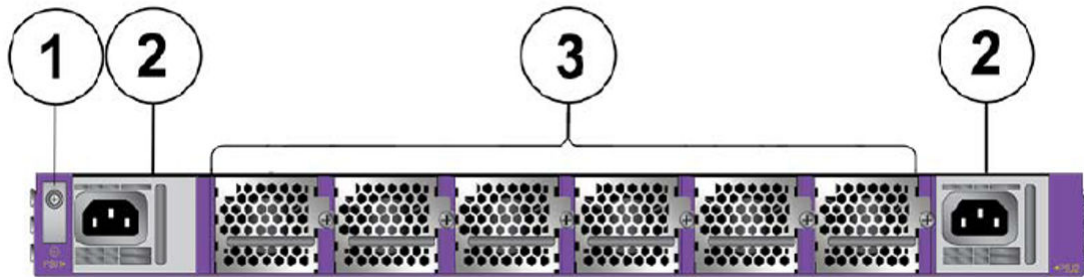

1. Grounding point
2. Power supply (AC input shown)
3. Fan modules

Figure 4: Rear-view or non-port-side view of the SLX 9640 Switch Router

Device management options

You can use the management functions built into the device to monitor the port status, physical status, and other information to help you analyze device performance and to accelerate system debugging. The device automatically performs a power-on self-test (POST) each time it is turned on.

You can manage the device using any of the management options listed in the following table.

Table 11: Management options for the device

Management tool	Out-of-band support	In-band support	Reference documents
Command line interface (CLI)	Ethernet or serial connection	N/A	<i>Extreme SLX-OS Management Configuration Guide</i>
REST or NETCONF/YANG APIs.	Ethernet connection	Yes	<i>Extreme SLX-OS Management Configuration Guide</i>
Standard SNMP applications	Ethernet or serial connection	N/A	<i>Extreme SLX-OS Management Configuration Guide</i>



Preparing for the Installation

[Safety precautions](#) on page 17

[Facility requirements](#) on page 20

[Quick installation checklist](#) on page 20

[Shipping carton contents](#) on page 21

Safety precautions

When using this product, observe all danger, caution, and attention notices in this manual. The safety notices are accompanied by symbols that represent the severity of the safety condition.

When using this product, observe all danger, caution, and attention notices in this manual. The safety notices are accompanied by symbols that represent the severity of the safety condition.

Refer to Cautions and Danger Notices at the end of this guide for translations of safety notices for this product.

General precautions



Warning

The procedures in this manual are for qualified service personnel.



Warning

Before beginning the installation, see the precautions in “Power precautions.”



Warning

Be careful not to accidentally insert your fingers into the fan tray while removing it from the chassis. The fan may still be spinning at a high speed.



Caution

Changes or modifications made to this device that are not expressly approved by the party responsible for compliance could void the user's authority to operate the equipment.



Caution

Disassembling any part of the power supply and fan assembly voids the warranty and regulatory certifications. There are no user-serviceable parts inside the power supply and fan assembly.

**Caution**

Make sure the airflow around the front, and back of the device is not restricted.

**Caution**

Ensure that the airflow direction of the power supply unit matches that of the installed fan tray. The power supplies and fan trays are clearly labeled with either a green arrow with an "E", or an orange arrow with an "I."

**Caution**

To protect the serial port from damage, keep the cover on the port when not in use.

**Caution**

Never leave tools inside the chassis.

**Caution**

If you do not install a module or a power supply in a slot, you must keep the slot filler panel in place. If you run the chassis with an uncovered slot, the system will overheat.

**Caution**

Use the screws specified in the procedure. Using longer screws can damage the device.

**Caution**

Do not install the device in an environment where the operating ambient temperature might exceed 50°C (122°F).

**Warning**

Batteries used for RTC/NVRAM backup are not located in operator-access areas. There is a risk of explosion if a battery is replaced by an incorrect type. Dispose of used components with batteries according to local ordinance and regulations.

ESD precautions

**Warning**

For safety reasons, the ESD wrist strap should contain a series 1 megaohm resistor.

**Caution**

Static electricity can damage the chassis and other electronic devices. To avoid damage, keep static-sensitive devices in their static-protective packages until you are ready to install them.

**Caution**

Before plugging a cable into any port, be sure to discharge the voltage stored on the cable by touching the electrical contacts to ground surface.

Power precautions

**Warning**

If the installation requires a different power cord than the one supplied with the device, make sure you use a power cord displaying the mark of the safety agency that defines the regulations for power cords in your country. The mark is your assurance that the power cord can be used safely with the device.

**Warning**

Disconnect the power cord from all power sources to completely remove power from the device.

**Warning**

This device might have more than one power cord. To reduce the risk of electric shock, disconnect all power cords before servicing.

**Warning**

To avoid high voltage shock, do not open the device while the power is on.

**Caution**

Use a separate branch circuit for each power cord, which provides redundancy in case one of the circuits fails.

**Caution**

Ensure that the device does not overload the power circuits, wiring, and over-current protection. To determine the possibility of overloading the supply circuits, add the ampere (amp) ratings of all devices installed on the same circuit as the device. Compare this total with the rating limit for the circuit. The maximum ampere ratings are usually printed on the devices near the input power connectors.

Lifting precautions

**Warning**

Use safe lifting practices when moving the product.

**Warning**

Mount the devices you install in a rack as low as possible. Place the heaviest device at the bottom and progressively place lighter devices above.

**Warning**

Make sure the rack housing the device is adequately secured to prevent it from becoming unstable or falling over.

**Caution**

To prevent damage to the chassis and components, never attempt to lift the chassis using the fan or power supply handles. These handles were not designed to support the weight of the chassis.

Laser precautions



Warning

All fiber-optic interfaces use Class 1 lasers.



Warning

Laser Radiation. Do Not View Directly with Optical Instruments. Class 1M Laser Products.



Warning

Use only optical transceivers that are qualified by Extreme Networks, Inc. and comply with the FDA Class 1 radiation performance requirements defined in 21 CFR Subchapter I, and with IEC 60825 and EN60825. Optical products that do not comply with these standards might emit light that is hazardous to the eyes.

Facility requirements

To install and operate the device successfully, ensure compliance with the following facility requirements.

Quick installation checklist

This checklist provides a high-level overview of the basic installation process from the planning stage to the point where the device comes online and is ready to be deployed. Completing all the tasks in the suggested order ensures successful installation. Extreme Networks recommends that you print this checklist and take it to the installation site.

Follow the steps listed in the Installation Prerequisites table below to install your device. Details for each of these steps are provided in the references indicated.

Table 12: Installation prerequisites

Task number	Task	Task details or additional information	Completed
1	Ensure that the physical environment that will host the device has the proper cabling and ventilation.	Refer to Facility requirements on page 20.	
2	If customizing an SLX 9640 Switch Router baseline chassis: <ol style="list-style-type: none"> 1. Install at least one power supply unit. 2. Install at least five fans. 	Refer to Inserting a new AC power supply on page 81. Refer to Inserting a new DC power supply on page 82. Refer to Inserting a new fan assembly on page 90.	
3	Mount the device on a desktop or in a rack	Refer to Installing the device in a rack on page 23.	
4	Attach a terminal or PC to the device. This will enable you to configure the device through the command line interface (CLI).	Refer to Establishing a serial connection on page 56.	

Table 12: Installation prerequisites (continued)

Task number	Task	Task details or additional information	Completed
5	Assign a password for additional access security. No default password is assigned to the CLI.	<i>Extreme SLX-OS Management Configuration Guide</i>	
6	Before attaching equipment to the device, you must configure an interface IP address to the subnet on which the device will be located. Initial IP address configuration is performed using the CLI with a direct serial connection.	<i>Extreme SLX-OS Management Configuration Guide</i>	
7	Connect an Ethernet connection to the system.	Refer to Establishing an Ethernet connection on page 59.	
8	Test IP connectivity to other devices by pinging them and tracing routes.	<i>Extreme SLX-OS Management Configuration Guide</i>	
9	Continue configuring the device using the CLI.	<i>Extreme SLX-OS Management Configuration Guide</i>	
10	Secure access to the device.	<i>Extreme SLX-OS Management Configuration Guide</i>	

Shipping carton contents

When unpacking the device, verify that the contents of the shipping carton is complete. Save the shipping carton and packaging in the event you need to return the shipment.

- The SLX 9640 Switch Router comes with an accessory kit containing the following items:
 - XBR-R000297 four-post rack mount kit
 - Serial cable with an RJ-45 connector
 - Two 6-ft. power cord
 - Power cord retainer clip
 - Rubber feet, required for setting up the device as a standalone unit China-RoHS Hazardous/Toxic Substance statement
 - EULA/Read-Me document
 - USB drive, 8G



Mounting the Device

[Mounting options on page 22](#)

[Mounting precautions on page 22](#)

[Standalone installation on page 23](#)

[Installing the device in a rack on page 23](#)

[Four-post rack mount kit installation \(XBR-R000297\) on page 24](#)

[Installing the Universal Two-Post Rack Kit \(XEN-R000294\) on page 28](#)

[Installing the Universal Four-Post Rack Kit \(XEN-R000296\) on page 38](#)

Mounting options

You can install the device in several ways:

- As a standalone unit on a flat surface, for example a desk top. Use the rubber feet included with the shipment to secure the device on the surface. No other equipment is required for desktop installation.
- In a four-post EIA rack using the flush-mount rack kit (XBR-R000297) included with the switch. The rack kit can be used to install devices in EIA racks that are between 46 cm and 79 cm (18 to 31 in.) deep.
- In a two-post Telco rack using the Universal Two-Post Rack Kit (XEN-R000294).. The two-post rack kit supports various mounting positions.
- In a four-post EIA rack using the Universal Four-Post Rack Kit (XEN-R000296). The rack kit can be used to install devices in EIA racks that are between L-13.7 to 81.28 cm deep (L-5.0 to 32.0 in.), where L is the chassis depth.



Note

Review the Safety Precautions [Safety precautions](#) on page 17 before mounting the device.



Note

These rack mount kits are supported for this device at the date of this publication. For the latest support information, contact your Extreme Networks representative.

Mounting precautions

The following precautions specifically apply to mounting the device.



Warning

Use safe lifting practices when moving the product.

**Warning**

Make sure the rack housing the device is adequately secured to prevent it from becoming unstable or falling over.

**Caution**

Make sure the airflow around the front, and back of the device is not restricted.

**Caution**

Never leave tools inside the chassis.

**Caution**

Use the screws specified in the procedure. Using longer screws can damage the device.

**Caution**

Do not install the device in an environment where the operating ambient temperature might exceed 50°C (122°F).

Standalone installation

Complete the following steps to install the device as a standalone unit on a table top.

1. Unpack the device and verify the items listed under "Items included with this device" are present and undamaged.
2. Apply the adhesive rubber feet to the device. The rubber feet help prevent the device from sliding off the supporting surface.
 - a. Clean the indentations at each corner of the bottom of the device to ensure that they are free of dust or other debris that might lessen the adhesion of the feet.
 - b. With the adhesive side against the chassis, place one rubber foot in each indentation and press into place.
3. Place the device on a flat, sturdy surface.
4. Provide power to the device as described under "Providing power to the device."

**Note**

Do not connect the device to the network until the IP address is correctly set. For instructions on how to set the IP address, refer to "Configuring the device IP address."

Installing the device in a rack

**Warning**

Make sure the rack housing the device is adequately secured to prevent it from becoming unstable or falling over.

**Note**

You need a #2 Phillips screwdriver for installation.

Before mounting the device in a rack, pay particular attention to the following factors:

- Temperature: Because the temperature within a rack assembly may be higher than the ambient room temperature, check that the rack-environment temperature is within the specified operating temperature range. (Refer to [Facility requirements](#) on page 20.)
- Mechanical loading: Do not place any equipment on top of a rack-mounted unit.
- Circuit overloading: Be sure that the supply circuit to the rack assembly is not overloaded.
- Grounding: Rack-mounted equipment should be properly grounded. Particular attention should be given to supply connections other than direct connections to the mains electricity supply.

To mount the product into a two-post rack, you can order the two-post rack kit with the part number XEN-R000294. For the procedure to install this kit, refer to “Installing the Universal Two-Post Rack Kit (XEN-R000294)” on page 16 .

To mount the product into a four-post rack, you can also order the four-post rack kit with the part number XEN-R000296. For the procedure to install this kit, refer to “Installing the Universal Four-Post Rack Kit (XEN-R000296)” on page 25.

To mount the product into a four-post rack using the included rack-mount kit, refer to “Four-post rack mount installation (XBR-R000297)” on page 12 for the installation procedure.

Four-post rack mount kit installation (XBR-R000297)

Use the following instructions to install the SLX 9640 device in EIA racks that are between 46 cm and 79 cm (18 to 31 in.) using the four-post flush-mount rack kit included with the switch.

Time and items required

Allow 15 to 30 minutes to complete the installation.

The following items are required to install the device using the Universal Four-Post Rack Kit:

- #2 Phillips torque screwdriver
- 1/4-inch slotted-blade torque screwdriver

Parts list

The following parts are provided with the four-post flush-mount rack kit (XBR-R000297).

Verify that the items below are included in the parts list.

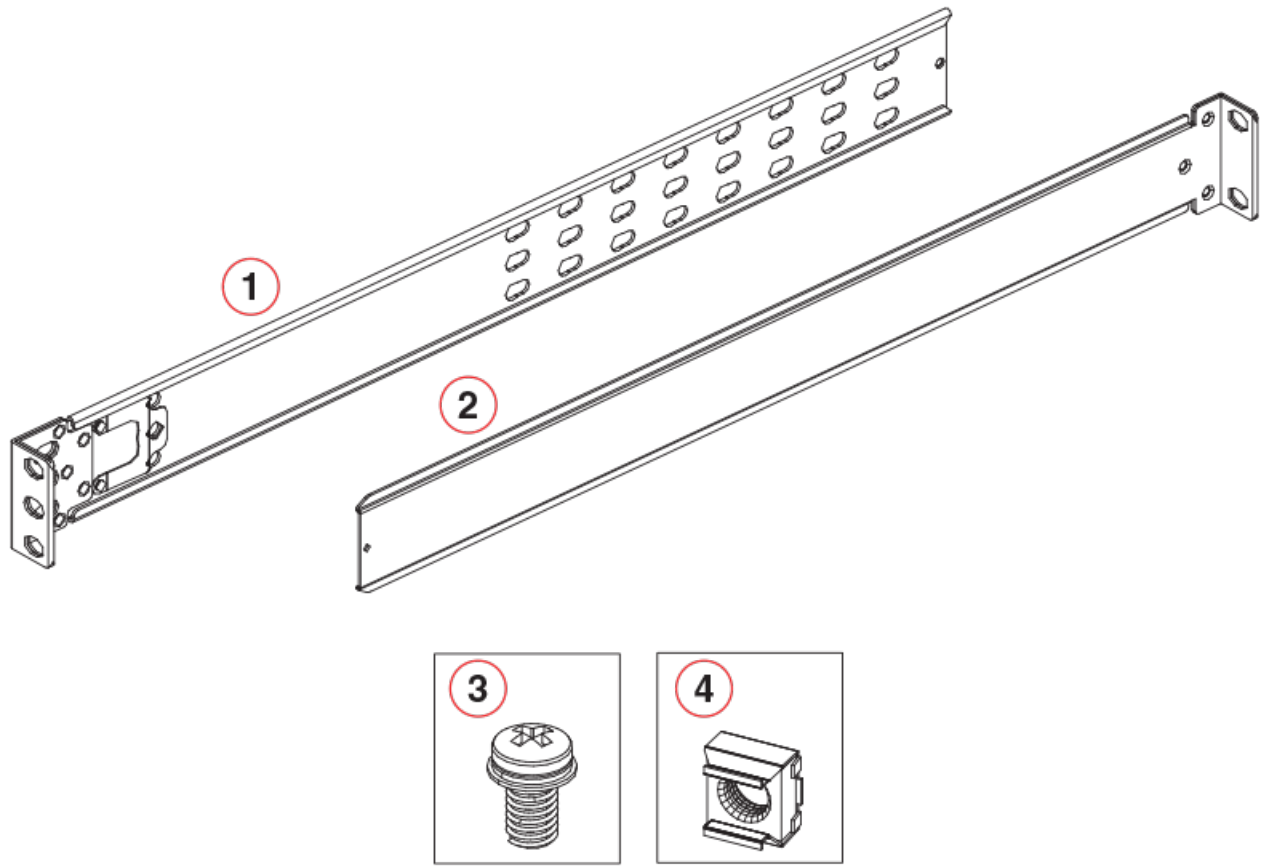

Figure 5: Items in the four-post flush-mount rack kit

1. Front brackets (2)
2. Rear brackets, long (2)
3. Screw, 10-32 x 5/8-in., panhead Phillips (12)
4. Retainer nut, 10-32 (12)

Ensure that the items listed and illustrated in Figure 3 are included in the kit.



Caution

Use the screws specified in the procedure. Using longer screws can damage the device.

Flush-front mounting



Caution

The device must be turned off and disconnected from the fabric during this procedure.

Complete the following tasks to install the device in a four-post rack.

1. [Attaching the front brackets](#) on page 26.
2. [Installing the device in the rack](#) on page 26.
3. [Attaching the rear brackets to the rack posts](#) on page 27.

Attaching the front brackets

Complete the following steps to attach the front brackets to the device.

1. Position the right front bracket with the flat side against the right side of the device at the front of the device, as shown in the figure below.
2. Use the six pre-installed 8-32 x 5/16-in. flathead screws to attach the bracket to the side of the device.
3. Repeat step 1 and step 2 to attach the left front bracket to the left side of the device.
4. Tighten all the 8-32 x 5/16-in. screws to a torque of 15 in-lb (17 cm-kg).

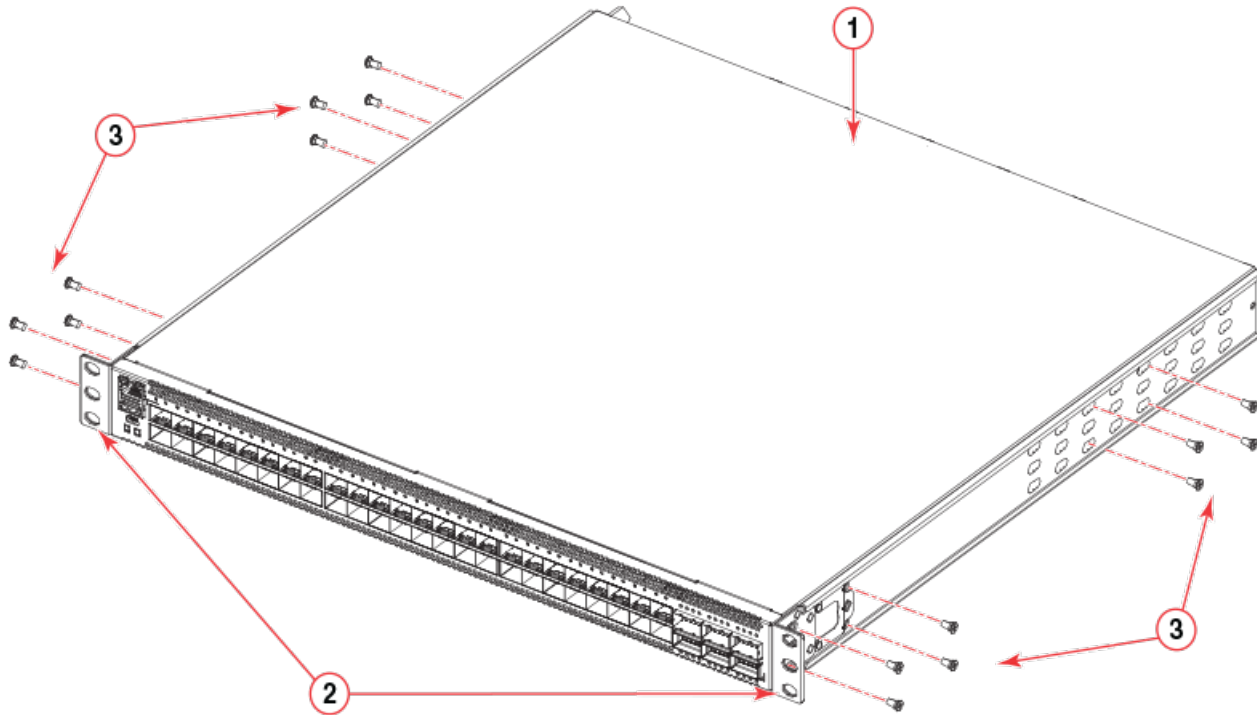

Figure 6: Attaching the front brackets to the device

- a. The SLX 9640 device
- b. Front brackets
- c. Screws, 8-32 x 5/16-in., flathead Phillips

Installing the device in the rack

Complete the following steps to install the device in the rack.

1. Position the device in the rack, as shown in the figure below, providing temporary support under the device until the rail kit is secured to the rack.
2. Attach the right front bracket to the right front rack post using three 10-32 x 5/8-in. panhead screws and three retainer nuts. Use the three holes in the bracket.
3. Attach the left front bracket to the left front rack post using three 10-32 x 5/8-in. panhead screws and three retainer nuts. Use the three holes in the bracket.

4. Tighten all the 10-32 x 5/8-in. screws to a torque of 25 in-lb (29 cm-kg).

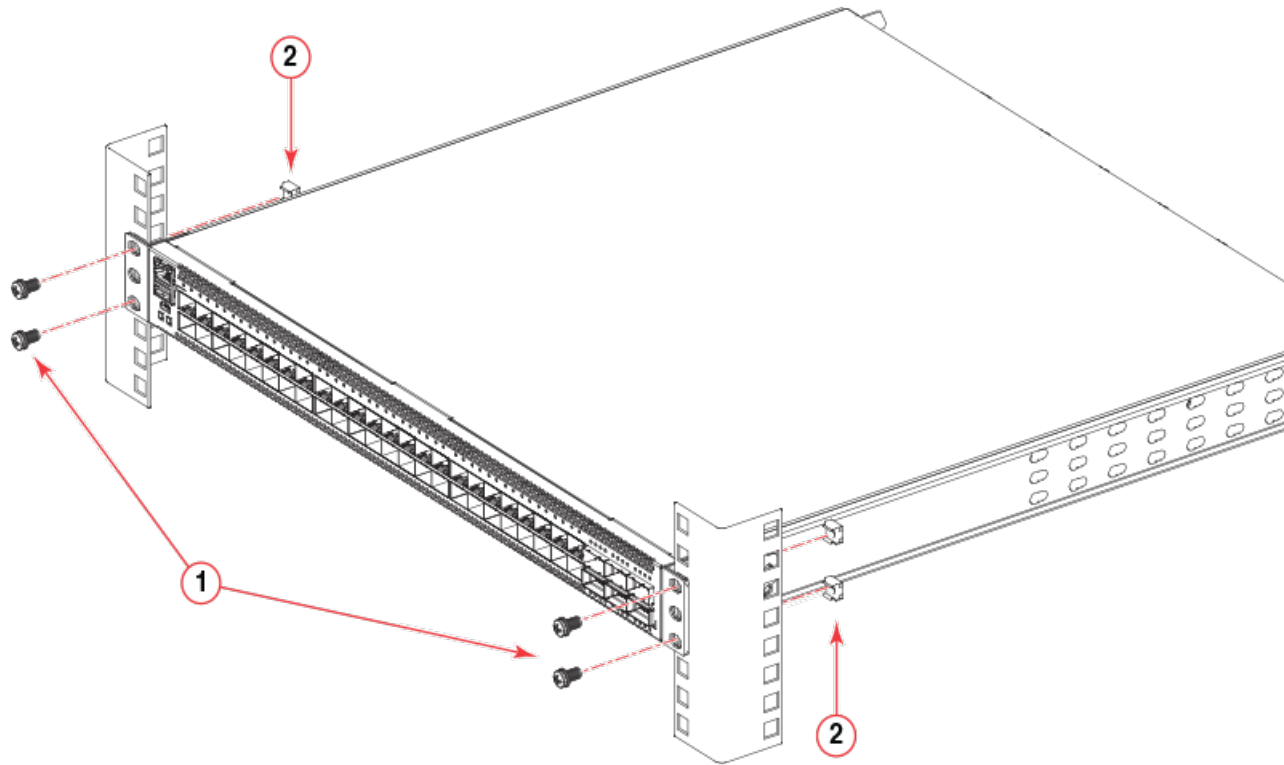

- a. Screws, 10-32 x 5/8-in., panhead Phillips
- b. Retainer nuts, 10-32

Figure 7: Installing the device in the rack

Attaching the rear brackets to the rack posts

Complete the following steps to attach the rear brackets to the rack posts.

1. Slide the right rear bracket into the right front bracket and the left rear bracket into the left front bracket.
2. Adjust the rear brackets to the rack depth.
3. Attach the right rear bracket to the right rear rack post using three 10-32 x 5/8-in. panhead screws and three retainer nuts, as shown in the figure below. Use the three holes in the bracket.
4. Attach the left rear bracket to the left rear rack post using three 10-32 x 5/8-in. panhead screws and three retainer nuts. Use the three holes in the bracket.
5. Tighten all the 10-32 x 5/8-in. screws to a torque of 25 in-lb (29 cm-kg).

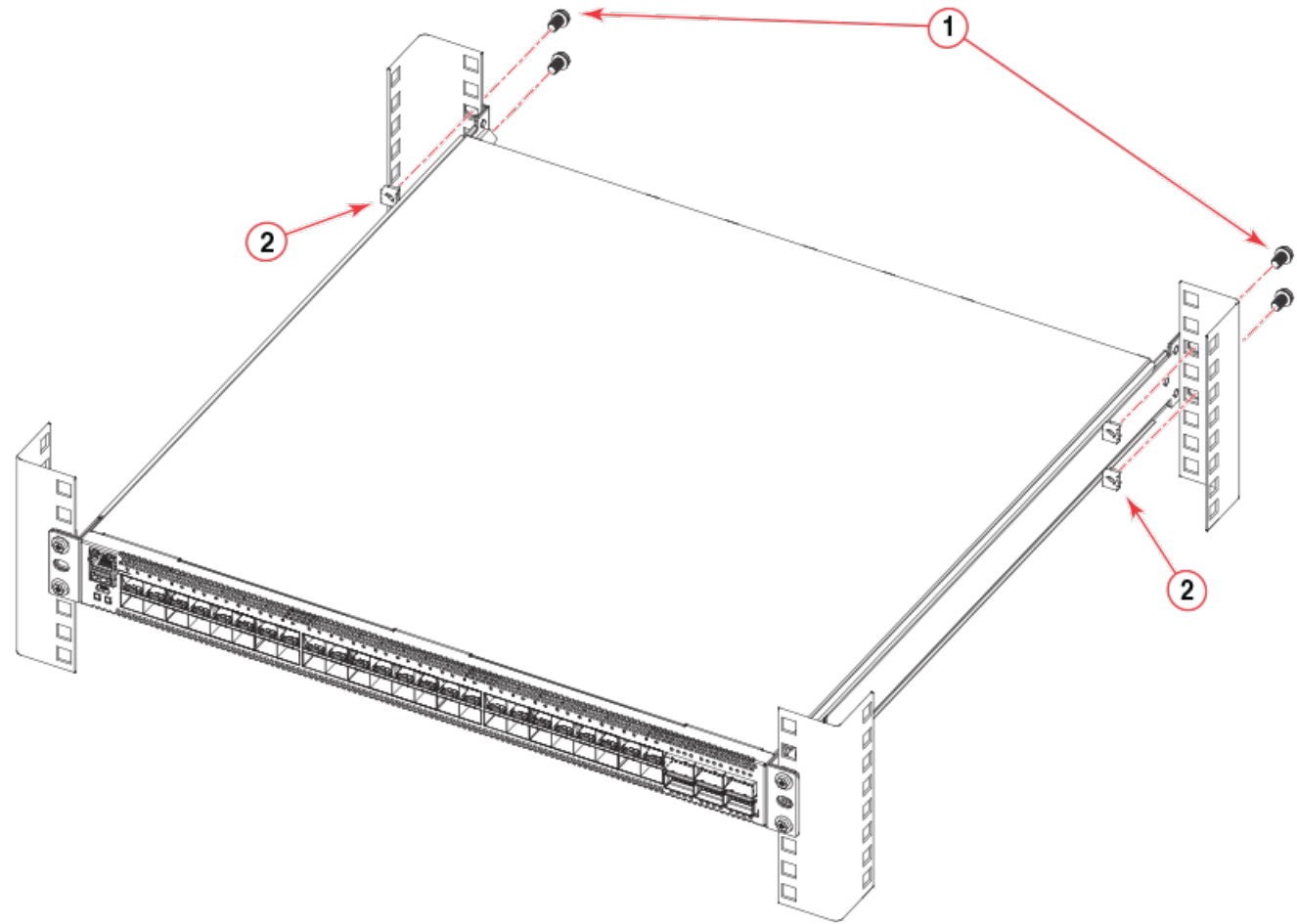

1. Screws, 10-32 x 5/8-in., panhead Phillips
2. Retainer nuts, 10-32

Figure 8: Attaching the rear brackets to the rack posts

Installing the Universal Two-Post Rack Kit (XEN-R000294)

Use the following instructions to install an Extreme Networks 1U or 2U device in a two-post telecommunications (Telco) rack using the Universal Two-Post Rack Kit (XEN-R000294).

There are two ways you can mount the device in a two-post rack:

- With the port side flush with the front posts
- With the posts mounted to the mid-section of the device

Observe the following when mounting this device:

- Two people are required to install the device in a rack. One person should hold the device, while the other screws in the front and rear brackets
- Before mounting your device, review any specific installation and facility requirements in the Hardware Installation Guide for the device.
- Hardware devices illustrated in these procedures are only for reference and may not depict the device you are installing in the rack.

Installation requirements

Review the installation and facility requirements for your product before mounting the device . Refer to the hardware installation guide for your product for more information.

Lifting requirements

For 1U and 2U devices, two people are required to install the device in a rack. One person holds the device, while the other screws in the front and rear "L" brackets.

Time and items required

Allow 15 to 30 minutes to complete the installation.

The following items are required to install the device using the Universal Two-Post Rack Kit:

- #2 Phillips torque screwdriver
- 1/4-inch slotted-blade torque screwdriver

Parts list

The following parts are provided with the Universal Two-Post Rack Kit (XEN-R000294).

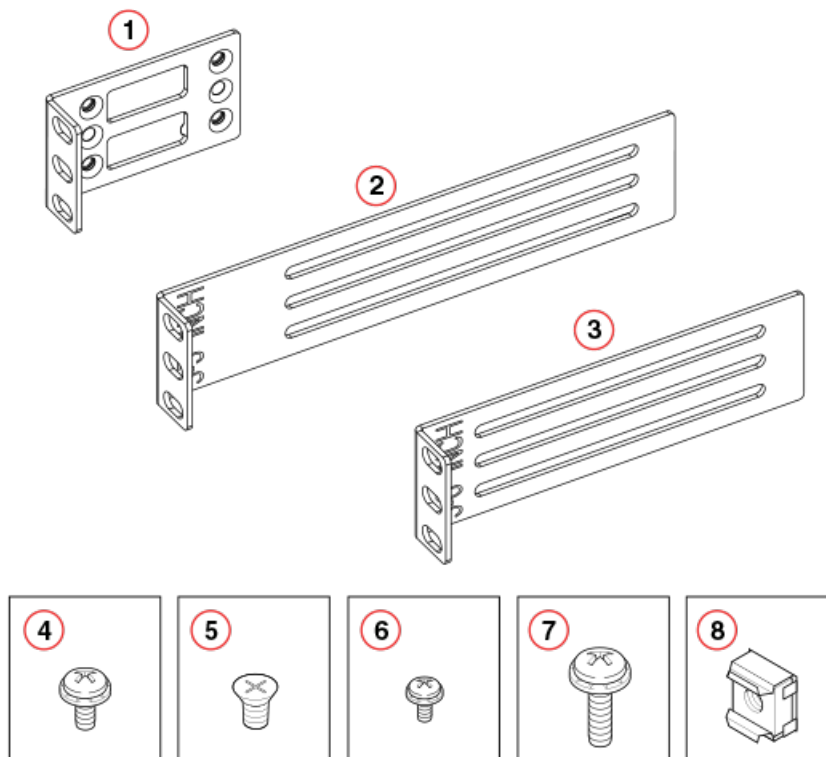

Figure 9: XEN-R000294 Rack Parts list

1. Front brackets (2)
2. Rear brackets 5-6 inch post (2)
3. Rear brackets 3-5 inch post (2)

4. Screw, 8-32 x 5/16-in., panhead Phillips (8)
5. Screw, 8-32 x 5/16-in., flathead Phillips (16)
6. Screw, 6-32 x 1/4-in., panhead Phillips (8)
7. Screw, 10-32 x 5/8-in., panhead Phillips (8)
8. Retainer nut, 10-32 (8)

Ensure that the items listed and illustrated in Figure are included in the kit. Note that not all parts may be used with certain installations depending on the device type.

**Caution**

Use the screws specified in the procedure. Using longer screws can damage the device.

Flush-front mounting

Observe the following notes when using this procedure:

- The device must be turned off and disconnected from the fabric during this procedure.
- The illustrations in this document show a 1U device, but the instructions are the same for a 2U device.
- The illustrations for this procedure show a two-post rack with narrow posts (3- to 5-inch) as an example.
- The illustrations in the rack installation procedures are for reference only and may not show the actual device.

**Caution**

Use the screws specified in the procedure. Using longer screws can damage the device.

Complete the following tasks to install the device in a rack:

1. [Attaching the front brackets to the device](#) on page 30
2. [Attaching the front brackets to the rack](#) on page 31
3. [Attaching the rear brackets to the rack](#) on page 32
4. [Attaching the rear brackets to the device](#) on page 33

Attaching the front brackets to the device

Complete the following steps to attach the front brackets to the device.

1. Position the right front bracket with the flat side against the right side of the device, as shown in [Figure 10](#).
2. Insert four 8-32 x 5/16-in. flathead screws through the vertically aligned holes in the bracket and then into the holes on the side of the device. Use the upper and lower screw holes, leaving the center holes empty.
3. Repeat step 1 and step 2 to attach the left front bracket to the left side of the device.

4. Tighten all the 8-32 x 5/16-in. screws to a torque of 15 in-lb (17 cm-kg).

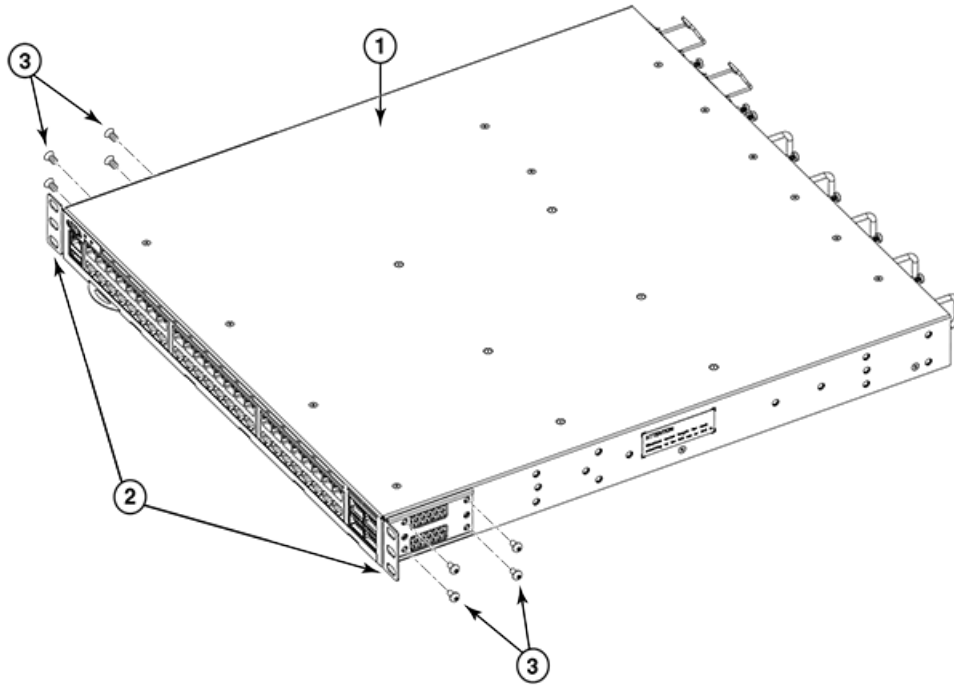

- a. The device
- b. Front brackets, right and left
- c. Screws, 8-32 x 5/16-in., flathead Phillips

Figure 10: Attaching the front brackets

Attaching the front brackets to the rack

Complete the following steps to install the device in the rack.

1. Position the device in the rack, as shown in [Figure 11](#) on page 32), providing temporary support under the device until the rack kit is fully secured to the rack.
2. Attach the right front bracket to the right rack upright using two 10-32 x 5/8-in. panhead screws and two retainer nuts. Use the upper and lower holes in the bracket.
3. Attach the left front bracket to the left rack upright using two 10-32 x 5/8-in. panhead screws and two retainer nuts.
Use the upper and lower holes in the bracket.

4. Tighten all the 10-32 x 5/8-in. screws to a torque of 25 in-lb. (29 cm-kg).

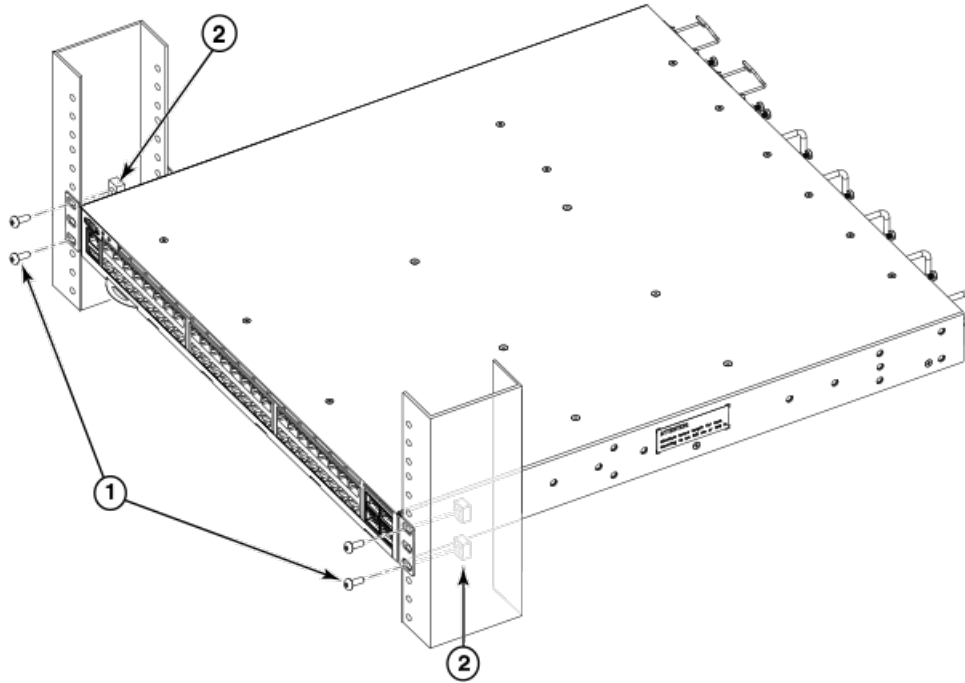

- a. Screws, 10-32 x 5/8-in., panhead Phillips
- b. Retainer nuts, 10-32

Figure 11: Attaching front brackets to a rack

Attaching the rear brackets to the rack

Complete the following steps to attach the rear brackets to the rack.

1. Select the proper length bracket for your post width. If your posts are three to five inches wide, use the brackets marked 3-5 INCH. If your posts are five to six inches wide, use the brackets marked 5-6 INCH.
2. Position the right rear bracket in the right rear of the device, as shown in [Attaching rear brackets to the rack](#).
3. Attach the bracket to the right rack upright using two 10-32 x 5/8-in. panhead screws and two retainer nuts. Use the upper and lower holes in the bracket.
4. Repeat step 2 and step 3 to attach the left rear bracket to the left rack upright.

5. Tighten all the 10-32 x 5/8-in. screws to a torque of 25 in-lb. (29 cm-kg).

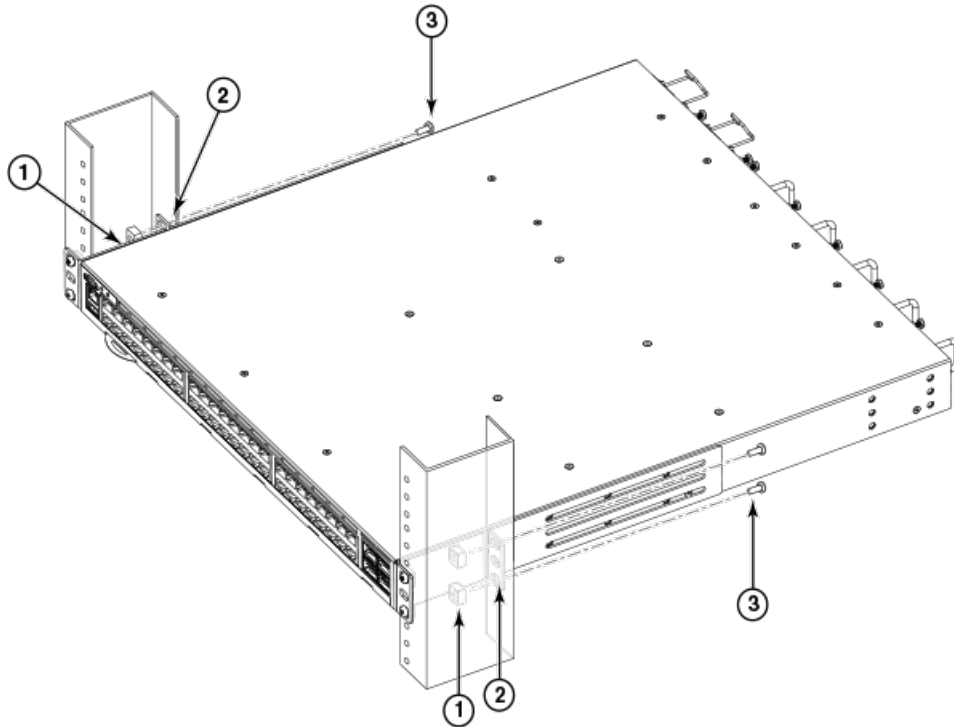

- a. Retainer nuts, 10-32
- b. Rear brackets
- c. Screws, 10-32 x 5/8-in., panhead Phillips

Figure 12: Attaching the rear brackets to a rack

Attaching the rear brackets to the device

Complete the following steps to attach the rear brackets to the device.

1. Align the right rear bracket to the right rear of the device and use four 8-32 x 5/16-in. panhead screws to attach the bracket to the device, as shown in [Figure 13](#). Be sure to insert the screws through the upper and lower slots in the bracket.
2. Align the left rear bracket to the left rear of the device and use four 8-32 x 5/16-in. panhead screws to attach the bracket to the device. Again, use the upper and lower slots in the bracket.

3. Tighten all the 8-32 x 5/16-in. screws to a torque of 15 in-lb (17 cm-kg).

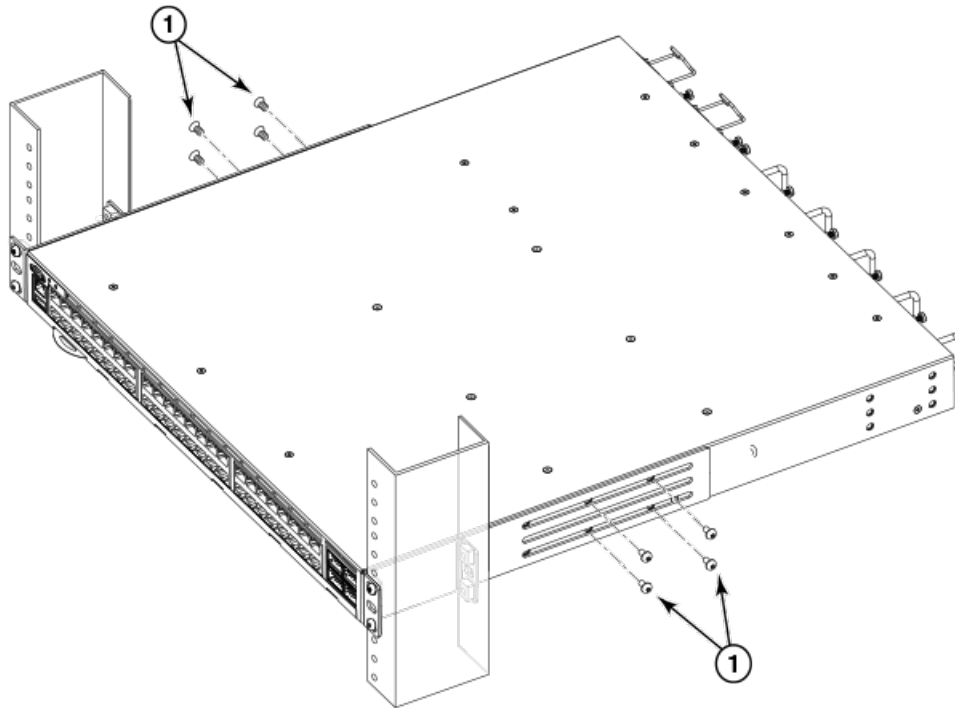

- a. Screws, 8-32 x 5/16-in., panhead Phillips

Figure 13: Attaching the rear brackets to the device

Mid-mounting

Observe the following notes when using this procedure:

- The device must be turned off and disconnected from the fabric during this procedure.
- The illustrations in this document show a 1U device, but the instructions are the same for a 2U device.
- The illustrations in the rack installation procedures are for reference only and may not show the actual device.

Complete the following tasks to install the device in a rack:

1. [Attaching the front brackets to the device](#) on page 34
2. [Attaching the front brackets to the rack](#) on page 35
3. [Attaching the rear brackets to the rack](#) on page 36
4. [Attaching the rear brackets to the device](#) on page 37

Attaching the front brackets to the device

Complete the following steps to attach the front brackets to the device.

1. Position the right front bracket with the flat side against the right side of the device, as shown in [Figure 14](#).
2. Insert four 8-32 x 5/16-in. flathead screws through the vertically aligned holes in the bracket and then into the holes on the side of the device. Use the upper and lower screw holes, leaving the center holes empty.

3. Repeat step 1 and step 2 to attach the left front bracket to the left side of the device.
4. Tighten all the 8-32 x 5/16-in. screws to a torque of 15 in-lb (17 cm-kg).

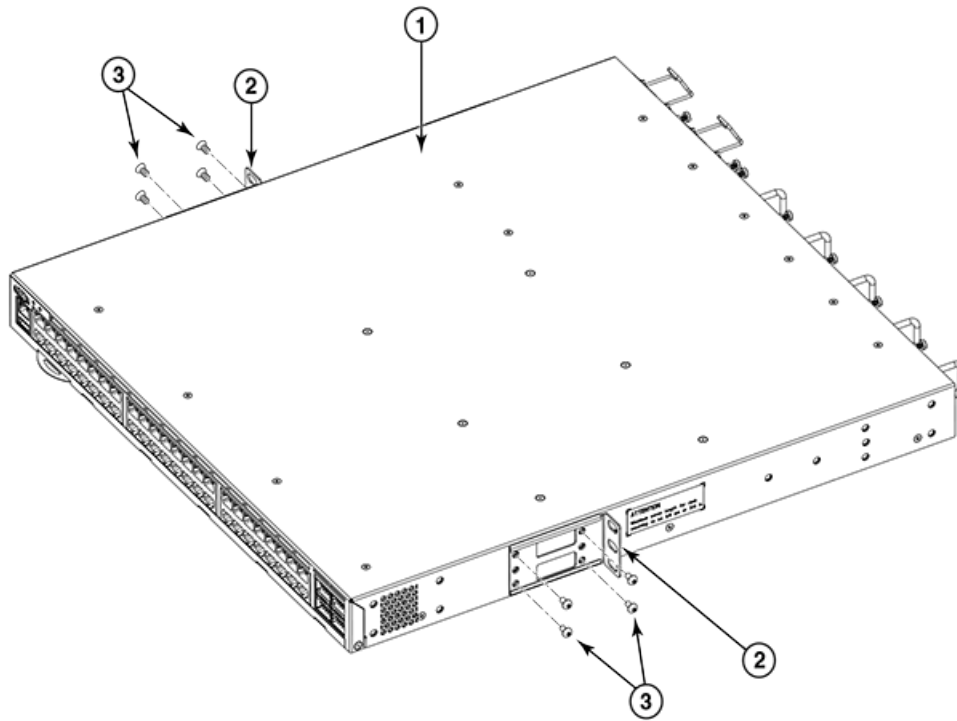

- a. The device
- b. Front brackets, right and left
- c. Screws, 8-32 x 5/16-in., flathead Phillips

Figure 14: Attaching the front brackets

Attaching the front brackets to the rack

Complete the following steps to install the device in the rack.

1. Position the device in the rack, as shown in [Figure 15](#), providing temporary support under the device until the rack kit is fully secured to the rack.
2. Attach the right front bracket to the right rack upright using two 10-32 x 5/8-in. screws and two retainer nuts. Use the upper and lower holes in the bracket.
3. Attach the left front bracket to the left rack upright using two 10-32 x 5/8-in. screws and two retainer nuts. Use the upper and lower holes in the bracket.

4. Tighten all the 10-32 x 5/8-in. screws to a torque of 25 in-lb (29 cm-kg).

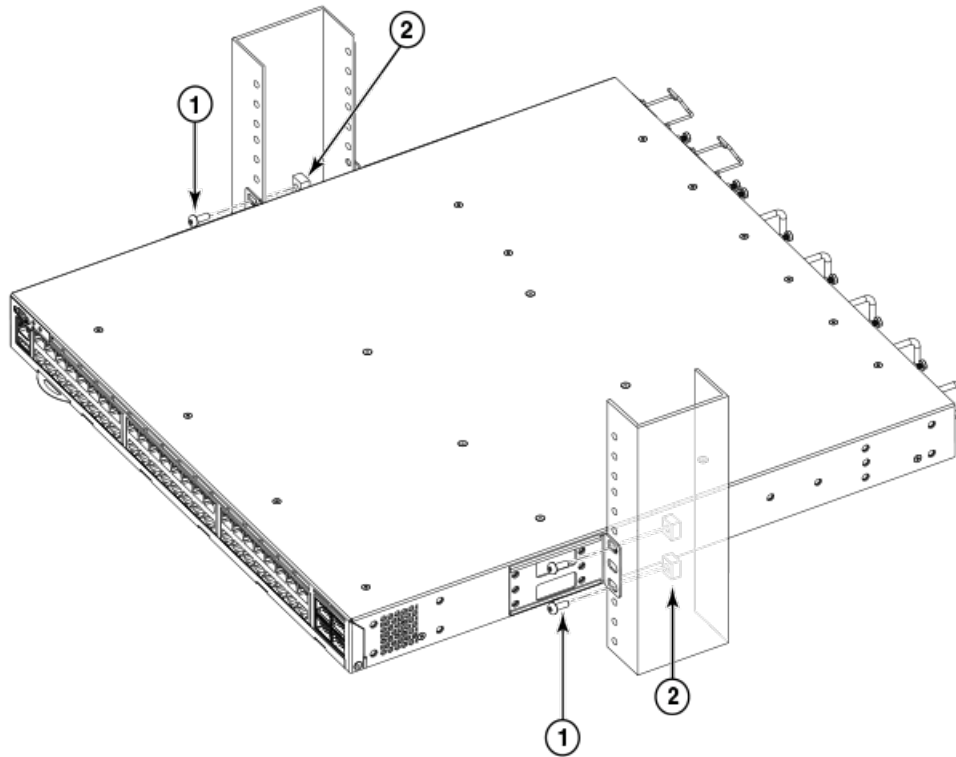

- a. Screws, 10-32 x 5/8-in., panhead Phillips
- b. Retainer nuts, 10-32

Figure 15: Attaching front brackets to a rack

Attaching the rear brackets to the rack

Complete the following steps to attach the rear brackets to the rack.

1. Select the proper length bracket for your post width. If your posts are three to five inches wide, use the brackets marked 3-5 INCH. If your posts are five to six inches wide, use the brackets marked 5-6 INCH.
2. Position the right rear bracket in the right rear of the device, as shown in the following figure. Whether you are using the 3-5 inch or the 5-6 inch bracket, the rear end of the bracket will be flush with the back of the device.
3. Attach the brackets to the right rack upright using two 10-32 x 5/8-in. panhead screws and two retainer nuts.
4. Repeat step 2 and step 3 to attach the left rear bracket to the left rack upright.

5. Tighten all the 10-32 x 5/8-in. screws to a torque of 25 in-lb (29 cm-kg).

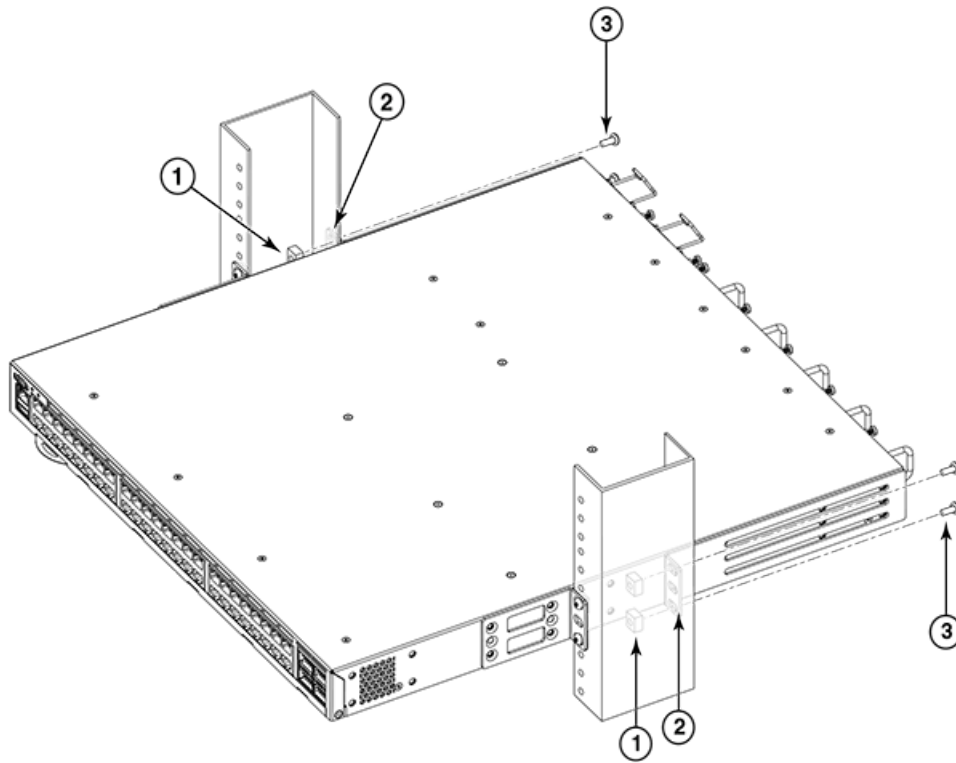

- a. Retainer nuts, 10-32
- b. Rear brackets (right and left)
- c. Screws, 10-32 x 5/8-in., panhead Phillips

Figure 16: Attaching the rear brackets to a rack

Attaching the rear brackets to the device

Complete the following steps to attach the rear brackets to the device.

1. Align the right rear bracket to the right rear of the device and use four 8-32 x 5/16-in. panhead screws to attach the bracket to the device, as shown in [Figure 17](#). Be sure to insert the screws through the upper and lower slots in the bracket.
2. Align the left rear bracket to the left rear of the device and use four 8-32 x 5/16-in. panhead screws to attach the bracket to the device. Again, use the upper and lower slots in the bracket.

3. Tighten all the 8-32 x 5/16-in. screws to a torque of 15 in-lb (17 cm-kg).

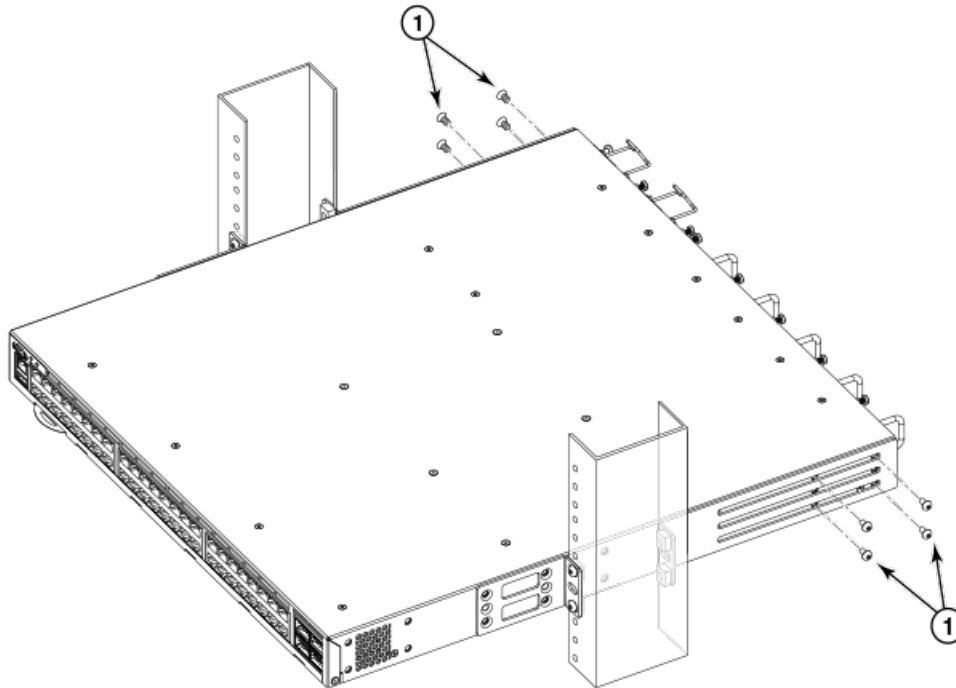

- a. Screws, 8-32 x 5/16-in., panhead Phillips

Figure 17: Attaching the rear brackets to the device

Installing the Universal Four-Post Rack Kit (XEN-R000296)

Use the following instructions to install 1U and 2U devices in EIA racks that are between L-12.7 to 81.28 cm deep (L-5.0 to 32.0 in.), where L is the chassis depth, using the Universal Four-Post Rack Kit (XBR-R000296).

There are two ways you can mount the device in a four-post rack:

- With the port side flush with the front posts.

- With the nonport side flush with the rear posts in a recessed position. A recessed position allows a more gradual bend in the fiber-optic cables connected to the switch and less interference in the aisle at the front of the rack.

Table 13: Space requirements

Chassis with port-side side vents	Notes	Chassis depth	Minimum rack depth	Maximum rack depth
No	Applicable to port-side and nonport-side flush mounts.	L	L-12.7 cm (L-5 in.)	81.28 cm (32 in.)
Yes	Applicable to port-side flush mounts.	L	L-12.7 cm (L-5 in.)	81.28 cm (32 in.)
Yes	Applicable to nonport-side flush mounts.	L	L	81.28 cm (32 in.)

Note that if chassis depth (L) is less than 40.64 cm (16 in.), the chassis will not fit into a rack with a maximum depth of 81.28 cm (32 in.) using the universal four-post rack kit. The maximum rack depth for a chassis less than 40.64 cm (16 in.) is 81.28 cm (32 in.) minus the difference between the chassis depth and 40.64 cm (16 in.). For example, a chassis with a depth (L) of 35.56 cm (14 in.) is 5.08 cm (2 in.) smaller than 40.64 cm (16 in.), so it will install into a rack with a maximum depth of 81.28 cm (32 in.) - 5.08 cm (2 in.) = 76.2 cm (30 in.).

Observe the following when mounting this device:

- Two people are required to install the device in a rack. One person holds the device, while the other screws in the front and rear brackets.
- Before mounting your device, review any specific installation and facility requirements in the Hardware Installation Guide for the device.
- Before mounting your device, review any specific installation and facility requirements in this Hardware Installation Guide.
- Hardware devices illustrated in these procedures are only for reference and may not depict the device you are installing into the rack.

Installation requirements

Provide space in an EIA rack with the following minimum and maximum distances between the front and back posts.



Note

For 1U and 2U devices, two people are required to install the device in a rack. One person holds the device, while the other screws in the front and rear "L" brackets.

Table 14: Space requirements

Chassis with port-side side vents	Notes	Chassis depth	Minimum rack depth	Maximum rack depth
No	Applicable to port-side and nonport-side flush mounts.	L	L-12.7 cm (L-5 in.)	81.28 cm (32 in.)
Yes	Applicable to port-side flush mounts.	L	L-12.7 cm (L-5 in.)	81.28 cm (32 in.)
Yes	Applicable to nonport-side flush mounts.	L	L	81.28 cm (32 in.)

Note that if chassis depth (L) is less than 40.64 cm (16 in.), the chassis will not fit into a rack with a maximum depth of 81.28 cm (32 in.) using the universal four-post rack kit. The maximum rack depth for a chassis less than 40.64 cm (16 in.) is 81.28 cm (32 in.) minus the difference between the chassis depth and 40.64 cm (16 in.). For example, a chassis with a depth (L) of 35.56 cm (14 in.) is 5.08 cm (2 in.) smaller than 40.64 cm (16 in.), so it will install into a rack with a maximum depth of 81.28 cm (32 in.) - 5.08 cm (2 in.) = 76.2 cm (30 in.).

Review the installation and facility requirements for your product before mounting the device. Refer to the *Hardware Installation Guide* for your product for more information.

Time and items required

Allow 15 to 30 minutes to complete the installation.

The following items are required to install the device using the Universal Four-Post Rack Kit:

- #2 Phillips torque screwdriver
- 1/4-inch slotted-blade torque screwdriver

Parts list

The following parts are provided with the Universal Four-Post Rack Kit (XEN-R000296).

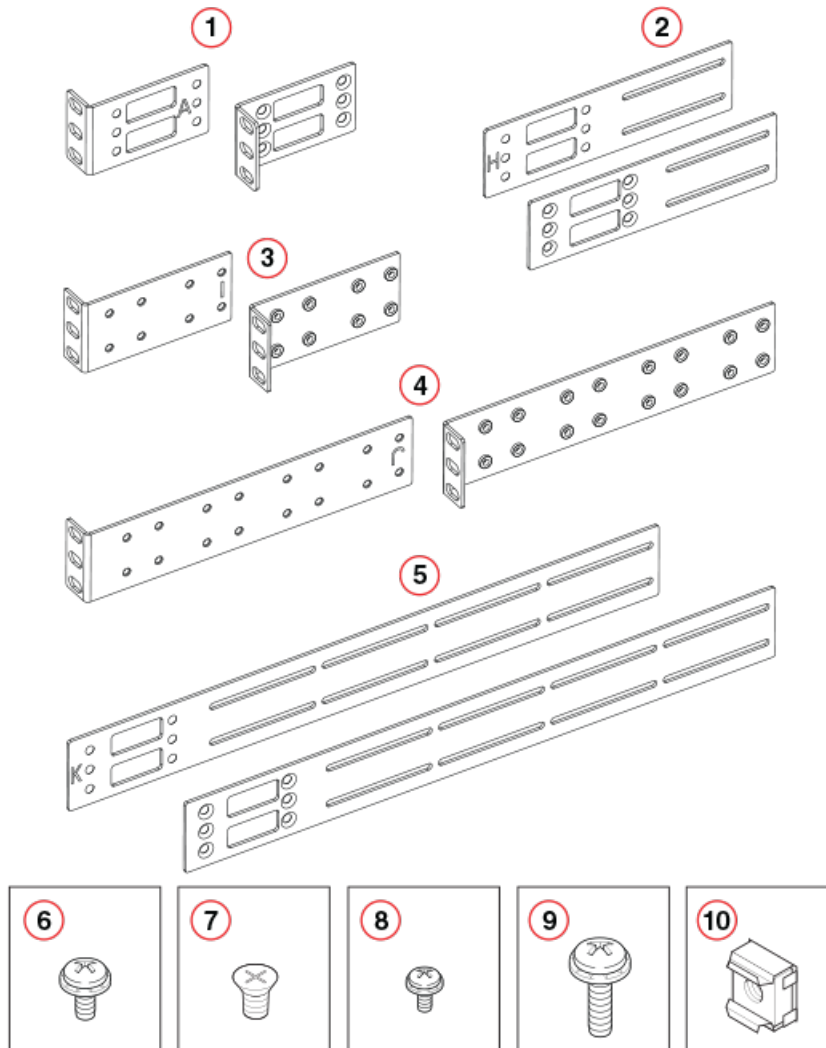

Figure 18: XEN-R000296 Rack Parts list

1. Front brackets (2)
2. Extension brackets, medium (2)
3. Rear brackets, short (2)
4. Rear brackets, long (2)
5. Extension brackets, long (2)
6. Screw, 8-32 x 5/16-in., panhead Phillips (8)
7. Screw, 8-32 x 5/16-in., flathead Phillips (16)
8. Screw, 8-32 x 5/16-in., flathead Phillips (16)
9. Screw, 10-32 x 5/8-in., panhead Phillips (8)
10. Retainer nut, 10-32 (8)

Ensure that the items listed and illustrated in [Figure 16](#) are included in the kit. Note that not all parts may be used with certain installations depending on the device type.

**Caution**

Use the screws specified in the procedure. Using longer screws can damage the device.

Flush-front mounting

**Caution**

The device must be turned off and disconnected from the fabric during this procedure.

**Note**

The illustrations in the rack installation procedures are for reference only and may not show the device that you are installing.

Complete the following tasks to install the device in a four-post rack.

1. [Attaching the front brackets](#)
2. [Attaching the bracket extensions to the device](#)
3. [Installing the device in the rack](#)
4. [Attaching the rear brackets to the extensions](#)
5. [Attaching the rear brackets to the rack posts](#)

Attaching the front brackets

Complete the following steps to attach the front brackets to the device.

1. Position the right front bracket with the flat side against the right side of the device at the front of the device, as shown in [Figure 19](#).
2. Insert four 8-32 x 5/16-in. flathead screws through the vertically aligned holes in the bracket and then into the holes on the side of the device. Use the upper and lower screw holes, leaving the center holes empty.
3. Repeat step 1 and step 2 to attach the left front bracket to the left side of the device.

4. Tighten all the 8-32 x 5/16-in. screws to a torque of 15 in-lb (17 cm-kg).

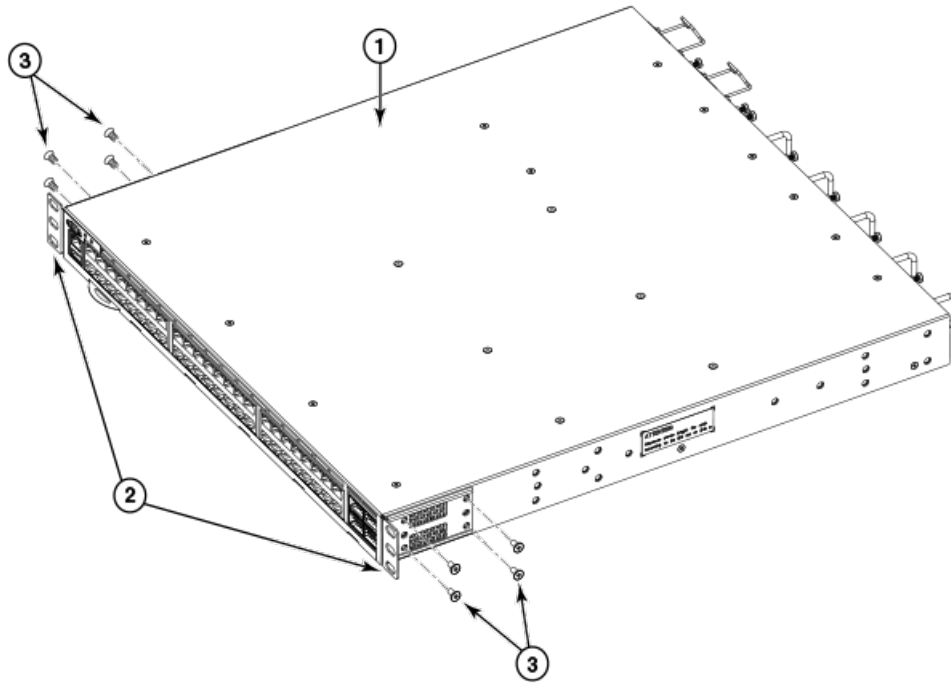

- a. The device
- b. Front brackets
- c. Screws, 8-32 x 5/16-in., flathead Phillips

Figure 19: Attaching the front brackets

Attaching the bracket extensions to the device

Complete the following steps to attach the extension brackets to the device. There are medium and long extension brackets that you can use for this step.

1. Select the proper length bracket extension for your rack depth.
2. Position the right bracket extension along the side of the device as shown in [Figure 20](#).
3. Insert four 8-32 x 5/16-in. flathead screws through the vertically aligned holes in the bracket extension and then into the holes on the side of the device. Use the upper and lower screw holes, leaving the center holes empty.
4. Repeat step 2 and step 3 to attach the left bracket extension to the left side of the device.

5. Tighten all the 8-32 x 5/16-in. screws to a torque of 15 in-lb (17 cm-kg).

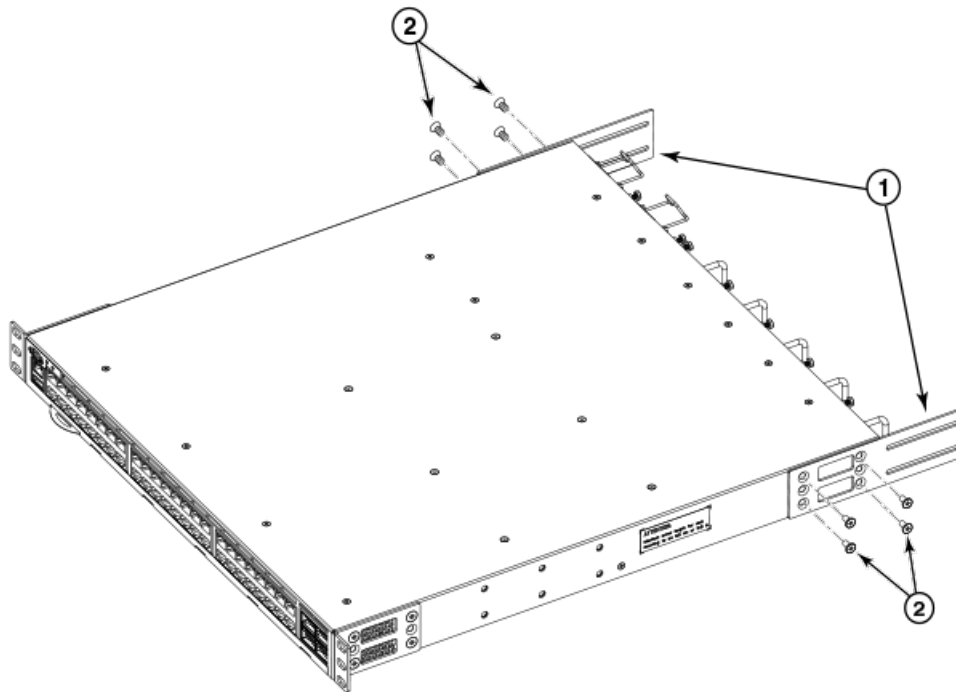

- a. Bracket extension
- b. Screws, 8-32 x 5/16-in., flathead Phillips

Figure 20: Attaching the bracket extensions to the device

Installing the device in the rack

Complete the following steps to install the device in the rack.

1. Position the device in the rack, as shown in [Figure 21](#), providing temporary support under the device until the rail kit is secured to the rack.
2. Attach the right front bracket to the right front rack post using two 10-32 x 5/8-in. panhead screws and two retainer nuts. Use the upper and lower holes in the bracket.
3. Attach the left front bracket to the left front rack post using two 10-32 x 5/8-in. panhead screws and two retainer nuts. Use the upper and lower holes in the bracket.

4. Tighten all the 10-32 x 5/8-in. screws to a torque of 25 in-lb (29 cm-kg).

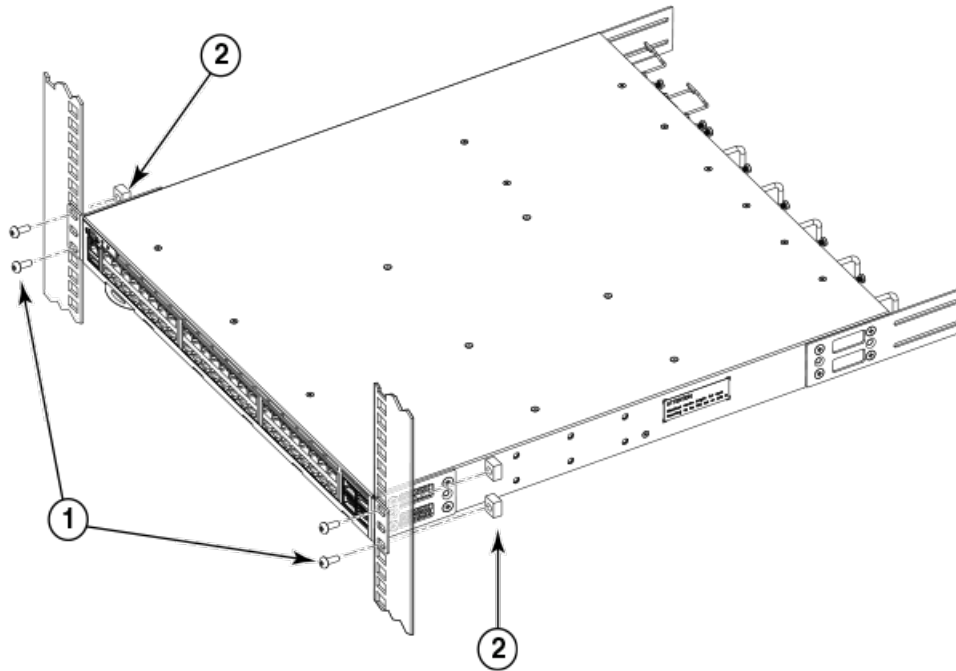

- a. Screws, 10-32 x 5/8-in., panhead Phillips
- b. Retainer nuts, 10-32

Figure 21: Positioning the device in the rack

Attaching the rear brackets to the extensions

Complete the following steps to attach the rear brackets to the extensions. There are short and long rear brackets that you can use for this step. Choose the correct bracket for the depth of your rack.

1. Select the proper length rear bracket for your rack depth.
2. Slide the right rear bracket onto the right bracket extension, as shown in the following figure.
3. Attach the brackets using four 6-32 x 1/4-in. panhead screws.

If possible, leave at least one empty vertical pair of holes between the screws for better support.

4. Repeat step 2 and 3 to attach the left rear bracket to the left bracket extension.

5. Adjust the brackets to the rack depth and tighten all the 6-32 x 1/4-in. screws to a torque of 9 in-lb (10 cm-kg).

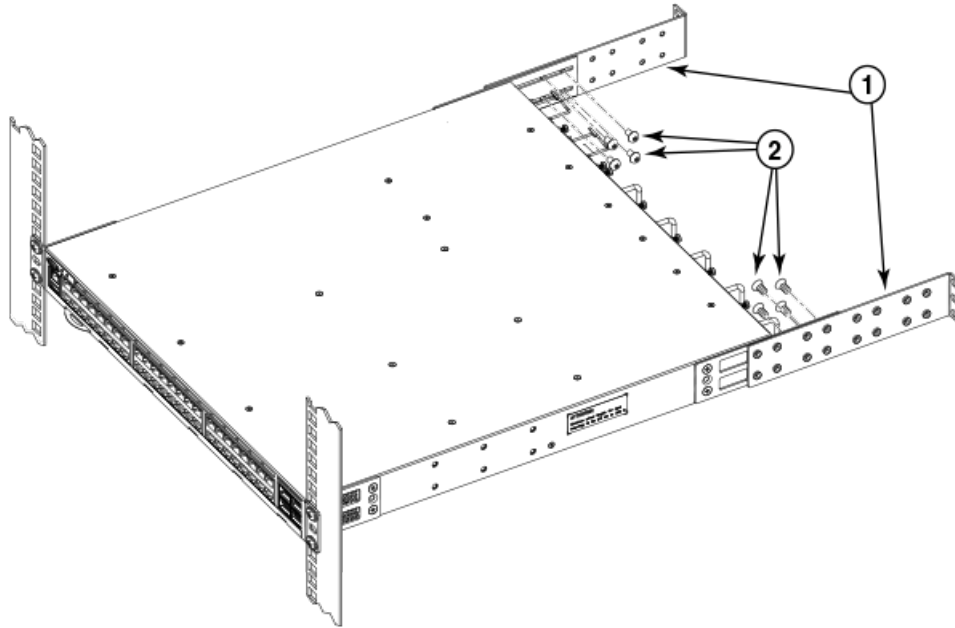

- a. Rear brackets
- b. Screws, 6-32 x 1/4-in., panhead Phillips

Figure 22: Attaching the rear brackets to the extensions

Attaching the rear brackets to the rack posts

Complete the following steps to attach the rear brackets to the rack posts.

1. Attach the right rear bracket to the right rear rack post using two 10-32 x 5/8-in. panhead screws and two retainer nuts, as shown in [Figure 23](#). Use the upper and lower holes in the bracket.
2. Attach the left rear bracket to the left rear rack post using two 10-32 x 5/8-in. panhead screws and two retainer nuts. Use the upper and lower holes in the bracket.

3. Tighten all the 10-32 x 5/8-in. screws to a torque of 25 in-lb (29 cm-kg).

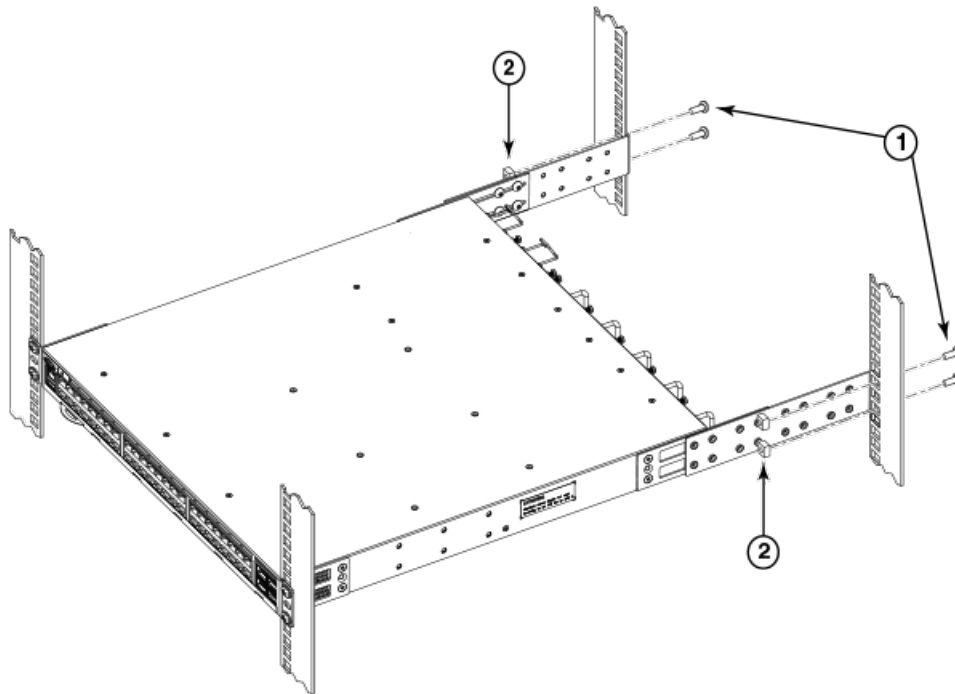

- a. Screws, 10-32 x 5/8-in., panhead Phillips
- b. Retainer nuts, 10-32

Figure 23: Attaching the rear brackets to the rack posts

Flush-rear (recessed) mounting

The flush-rear (recessed) mounting is similar to the flush-front mounting except that the brackets are reversed on the device.



Caution

The device must be turned off and disconnected from the fabric during this procedure.



Note

The illustrations in the rack installation procedures show a 1U device, but the instructions are the same for a 2U device. The illustrations in the rack installation procedures are for reference only and may not show the actual device.

Complete the following tasks to install the device in a four-post rack:

1. [Attaching the front brackets to the rear of the device](#)
2. [Attaching the extensions to the front of the device](#)
3. [Installing the device in the rack](#)
4. [Attaching the rear brackets to the extensions at the front of the device](#)
5. [Attaching the rear brackets to the front rack posts](#)

Attaching the front brackets to the rear of the device**Note**

In this installation, the brackets are named as listed in the parts list even though the installation of the brackets is reversed from the flush-front installation.

Complete the following steps to attach the front brackets to the rear of the device.

1. Position the right front bracket with the flat side against the right rear side of the device, as shown in [Figure 24](#).
2. Insert four 8-32 x 5/16-in. flathead screws through the vertically aligned holes in the bracket and then into the holes on the side of the device. Use the upper and lower screw holes, leaving the center holes empty.
3. Repeat step 1 and step 2 to attach the left front bracket to the left side of the device.
4. Tighten all the 8-32 x 5/16-in. screws to a torque of 15 in-lb (17 cm-kg).

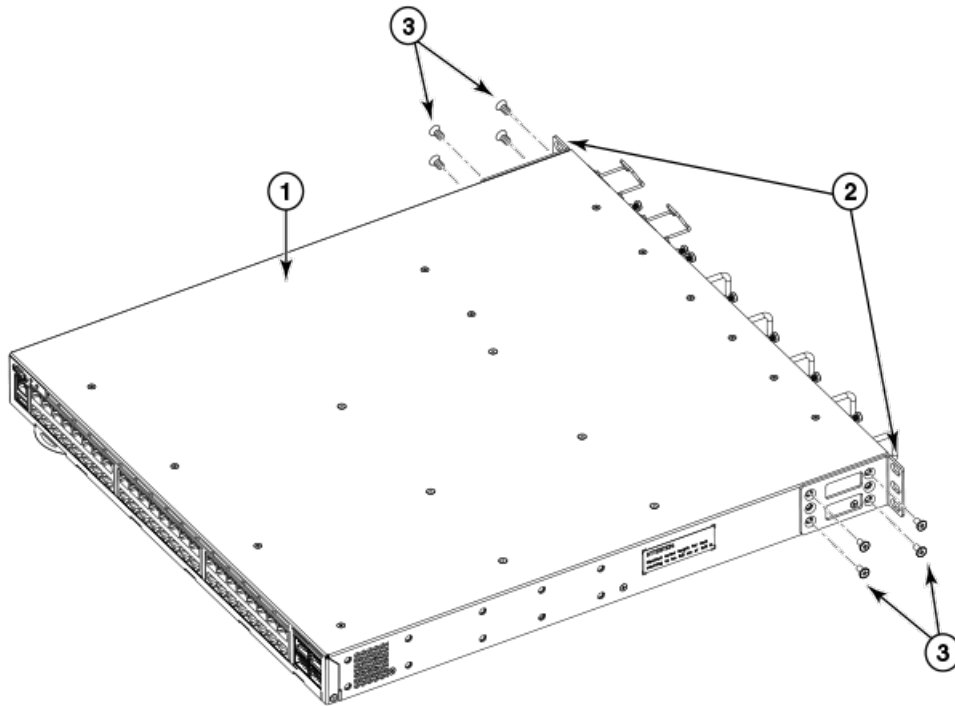

- a. The device
- b. Front brackets
- c. Screws, 8-32 x 5/16-in., flathead Phillips

Figure 24: Attaching the front brackets to the rear of the device

Attaching the bracket extensions to the front of the device

Complete the following steps to attach the bracket extensions to the front of the device. There are medium and long extension brackets that you can use for this step.

1. Select the proper length extension bracket for your rack depth.
2. Position the right bracket extension along the side of the device as shown in [Figure 25](#) on page 49.

3. Insert four 8-32 x 5/16-in. flathead screws through the vertically aligned holes in the bracket extension and then into the holes on the side of the device. Use the upper and lower screw holes, leaving the center holes empty.
4. Repeat step 2 and step 3 to attach the left front bracket extension to the left side of the device.
5. Tighten all the 8-32 x 5/16-in. screws to a torque of 15 in-lb (17 cm-kg).

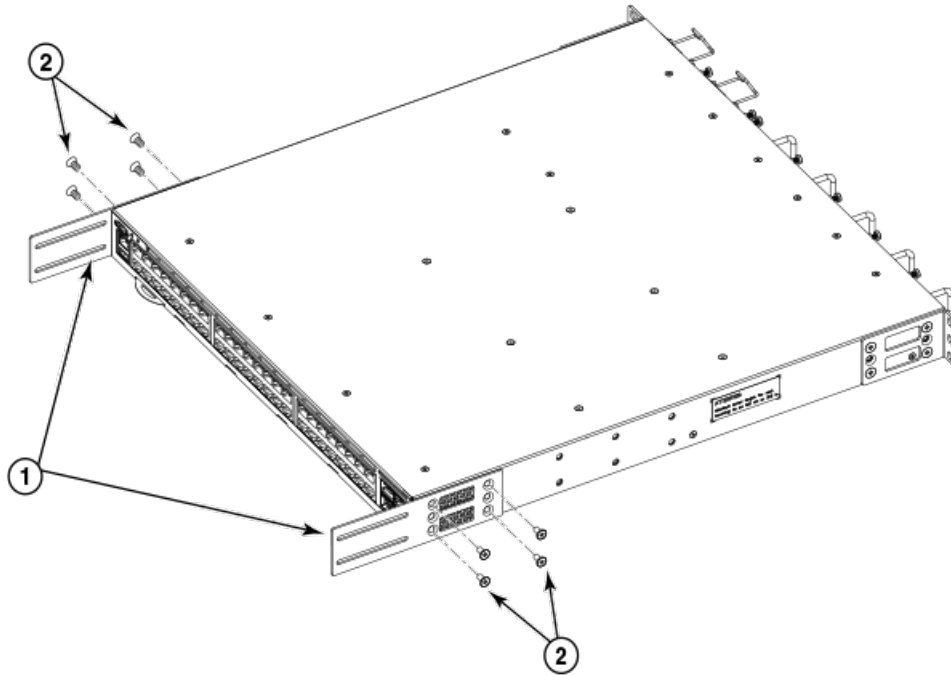

- a. Extension brackets
- b. Screws, 8-32 x 5/16-in., flathead Phillips

Figure 25: Attaching the bracket extensions to the device

Installing the device in the rack

Complete the following steps to install the device in the rack.

1. Position the device in the rack, as shown in [Figure 26](#), providing temporary support under the device until the rail kit is secured to the rack.
2. Attach the right front bracket to the right rear rack post using two 10-32 x 5/8-in. panhead screws and two retainer nuts. Use the upper and lower holes in the bracket.
3. Attach the left front bracket to the left rear rack post using two 10-32 x 5/8-in. panhead screws and two retainer nuts. Use the upper and lower holes in the bracket.

4. Tighten all the 10-32 x 5/8-in. screws to a torque of 25 in-lb (29 cm-kg).

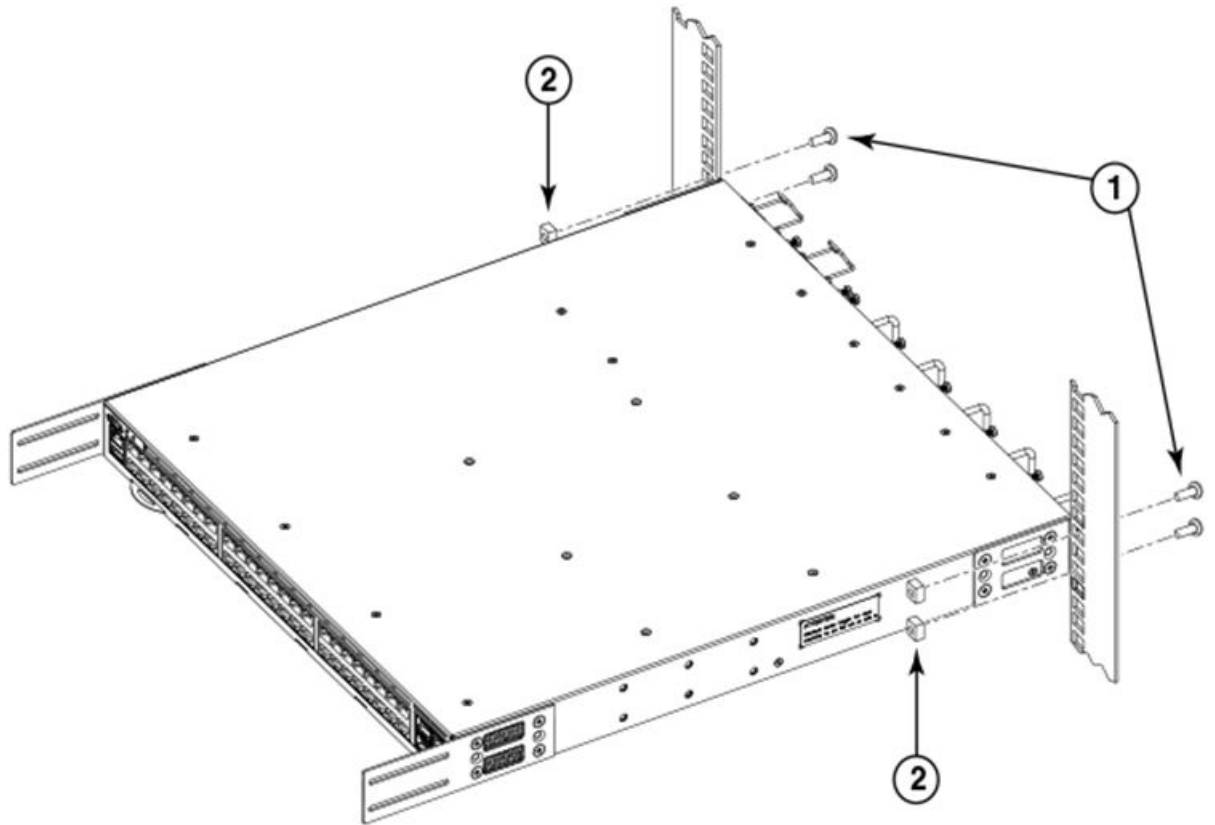

- a. Screws, 10-32 x 5/8-in., panhead Phillips
- b. Retainer nuts, 10-32

Figure 26: Positioning the device in the rack

Attaching the rear brackets to the extensions at the front of the device

Complete the following steps to attach the rear brackets to the extensions. There are short and long front brackets that you can use for this step.

1. Select the proper length rear bracket for your rack depth.
2. Slide the right rear bracket onto the right extension.

The short rear brackets are shown in [Figure 27](#) on page 51. Use the first and third vertical pairs of holes for the screws.

Refer to [Figure 28](#) on page 52 for the positioning of the short or long brackets and screws.

3. Attach the brackets using four 6-32 x 1/4-in. panhead screws.
4. Repeat step 2 and step 3 to attach the left rear bracket to the left extension.

5. Adjust the brackets to the rack depth and tighten all the 6-32 x 1/4-in. screws to a torque of 9 in-lb (10 cm-kg).

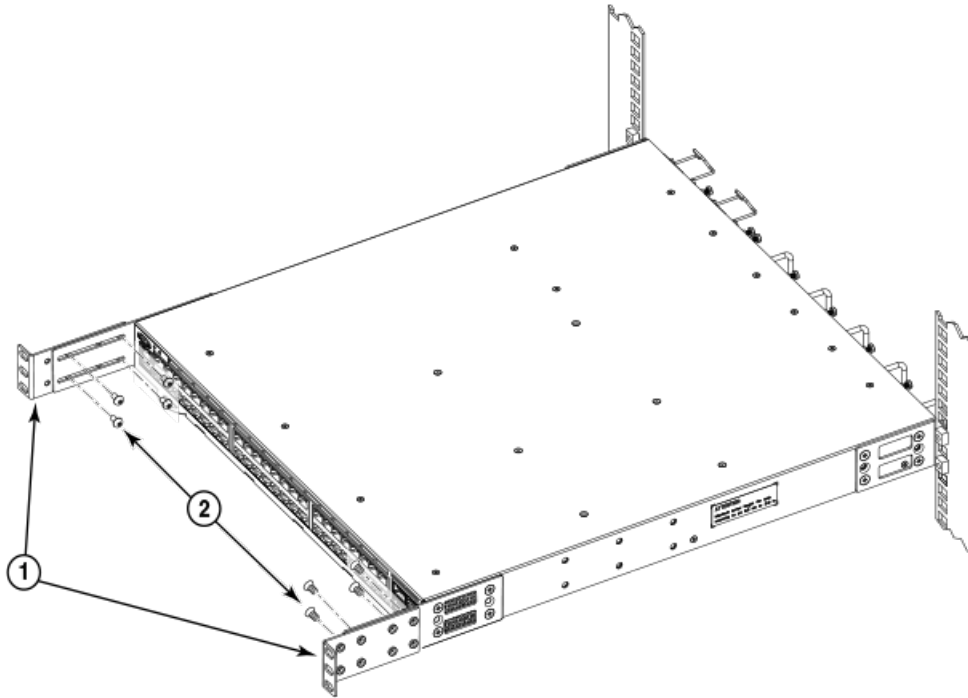

- a. Rear brackets, short
- b. Screws, 6-32 x 1/4-in., panhead Phillips

Figure 27: Attaching the rear brackets to the extensions at the front of the device

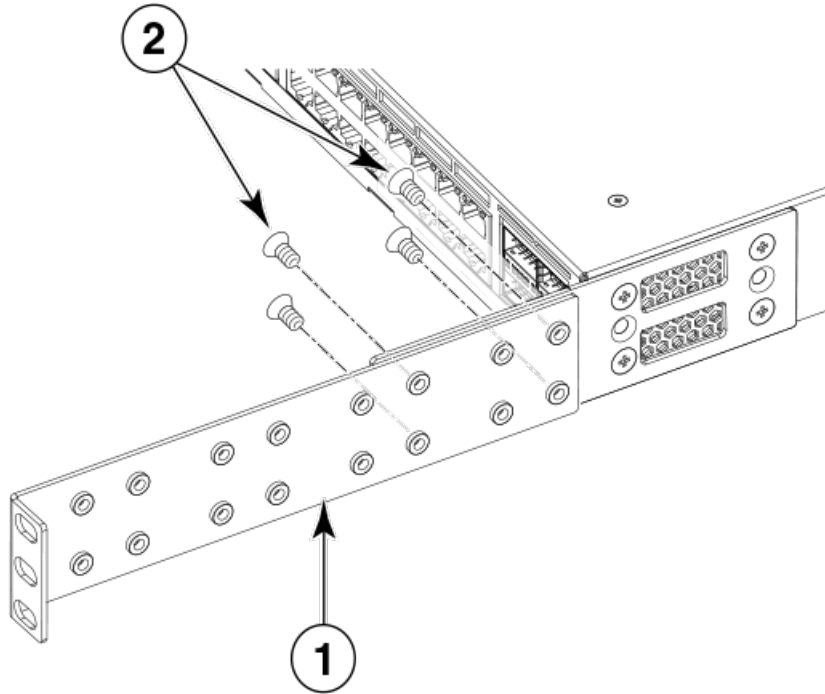

- a. Rear bracket, short or long
- b. Screws, 6-32 x 1/4-in., panhead Phillips

Figure 28: Attaching the short or long rear brackets to the extensions

Attaching the rear brackets to the front rack posts

Complete the following steps to attach the rear brackets to the front rack posts.

1. Attach the right rear bracket to the right front rack post using two 10-32 x 5/8-in. screws and two retainer nuts, as shown in [Figure 29](#). Use the upper and lower holes in the bracket.
2. Attach the left rear bracket to the left front rack post using two 10-32 x 5/8-in. screws and two retainer nuts. Use the upper and lower holes in the bracket.

3. Tighten all the 10-32 x 5/8-in. screws to a torque of 25 in-lb (29 cm-kg).

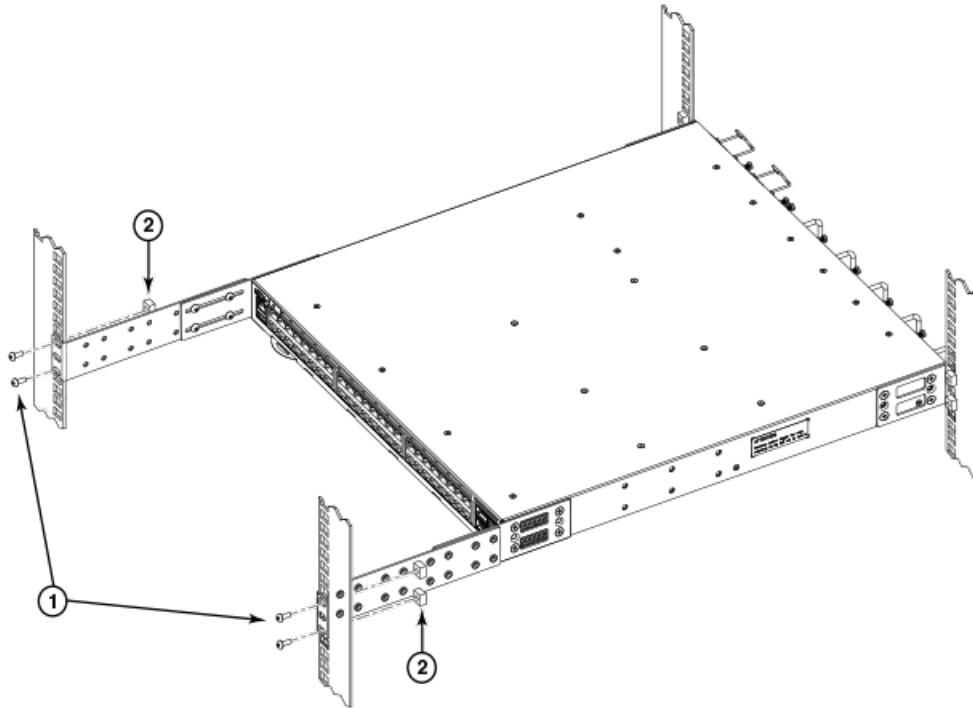

- a. Screws, 10-32 x 5/8-in., panhead Phillips
- b. Retainer nuts, 10-32

Figure 29: Attaching the rear brackets to the front rack posts

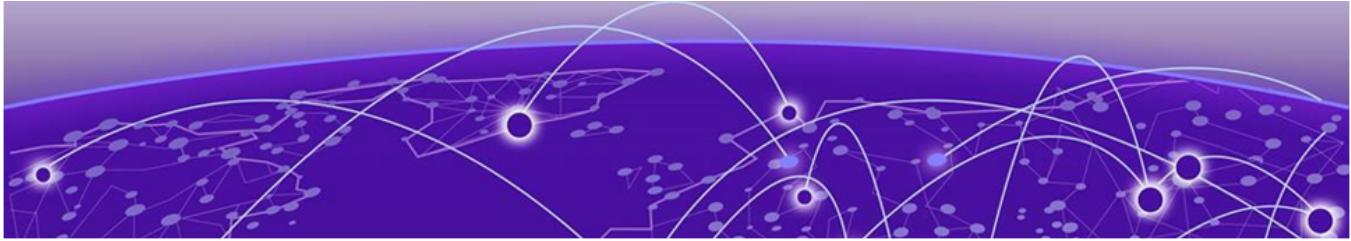

Initial Setup and Verification

[Initial setup and configuration checklist](#) on page 54

[Items required](#) on page 55

[Providing power to the device](#) on page 56

[Establishing a serial connection](#) on page 56

[Configuring a static IP address](#) on page 58

[Establishing an Ethernet connection](#) on page 59

[Customizing the chassis and host names](#) on page 60

[Configuring the DNS service](#) on page 61

[Setting the date and time](#) on page 61

[Verifying correct operation](#) on page 61

[Backing up the configuration](#) on page 62

[Installing cable management kit](#) on page 62

Initial setup and configuration checklist

Use the procedures in the following table to initially configure and setup the device, verify correct operation, and back up the configuration.

Table 15: Initial setup and configuration checklist

Task	Task details or additional information
Attach a management station, establish a serial connection, and change the default passwords (optional).	Refer to Establishing a serial connection on page 56. After completing this task, log in to the serial port to configure the device.
Set the IP address, subnet mask, and the default gateway IP address.	Use the chassis virtual-ip or chassis virtual-ipv6 commands to configure an IP address. For more information, refer to Configuring a static IP address on page 58 .
Establish an Ethernet connection.	By establishing an Ethernet connection, you can complete the device configuration using a serial or Telnet session. Refer to Establishing an Ethernet connection on page 59 for more information.
Customize the chassis and host names.	Use the switch-attributes chassis-name and switch-attributes host-name commands to change the default host name. For more information, refer to Customizing the chassis and host names on page 60 .

Table 15: Initial setup and configuration checklist (continued)

Task	Task details or additional information
Set the date and time.	<ul style="list-style-type: none"> • Use the clock set command to set the date and time. • Use the clock timezone command to set the time zone. • After you configure the system time, use commands in NTP configuration mode to synchronize the time with an external NTP server. <p>Refer to Setting the date and time on page 61 for more information. For detailed command information, refer to <i>Extreme SLX-OS Management Configuration Guide</i> for the SLX 9640 device.</p>
Optional: Configure the DNS service.	<p>Use the ip dns domain-name and, if required, the ip dns name-server command to create DNS server entries. Refer to Configuring the DNS service on page 61 for more information. For detailed command information refer to <i>Extreme SLX-OS Security Configuration Guide</i> for the SLX 9640 device.</p>
Verify that the device operates correctly.	<ul style="list-style-type: none"> • Check the LEDs to verify operation of module components in the device. Refer to ExtremeRouting SLX 9640 Technical Specifications on page 92. • The following commands can be useful to establish an operational baseline for the device. Refer to <i>Extreme SLX-OS Monitoring Configuration Guide</i> for the SLX 9640 device for more information about these commands. <ul style="list-style-type: none"> ◦ show chassis ◦ show system ◦ show slots ◦ show linecard ◦ show environment fan ◦ show environment power ◦ show environment sensor ◦ show environment temp
Back up the configuration.	<p>Use the copy running-config command to copy the running configuration to the startup configuration. Refer to Backing up the configuration on page 62 for more information about this command.</p>

Items required

The following items are required for initial setup and verification of the device:

- The device, mounted and installed with the required interface modules, FRUs, transceivers, and cables, and connected to a power source.
- A workstation computer with an installed terminal emulator application, such as HyperTerminal for Windows.
- An unused IP address with corresponding subnet mask and gateway address.
- A serial cable (provided) with an RJ-45 connector.
- Two Ethernet cables (one per management module).

- Optional: Access to an FTP server or USB device for backing up (uploading) or downloading the device configuration or collecting diagnostic output data.
- Optional: An Extreme USB drive for backing up (uploading) or downloading the device configuration or collecting diagnostic output data.

Providing power to the device

After you complete the physical installation, you can power on the system.

1. Install alternating-current (AC) or direct-current (DC) power supplies in the switch. Refer to [Power Supplies](#) on page 77 .
2. Connect AC or DC power cables to the power supply connectors on the rear panel.



Note

The equipment should be installed near a power source and in an easily accessible location.

3. Connect the power cables to the 100-240 VAC or 48-60 VDC power source. The power sources should be on separate circuits to protect against power failure. Ensure that the power cords have a minimum service loop of 6 inches available and are routed to avoid stress.



Note

Power is supplied to the device as soon as the first power supply is connected.

4. After the device has booted, verify that the power and status LEDs are green. The power supply LEDs display amber until power-on self-test (POST) is complete, and then change to green. The switch usually requires several minutes to boot and complete POST.



Note

To turn the system off, simply unplug the power cables.

For more information about how to interpret LEDs and run diagnostics tests, refer to [LED indicators](#) on page 74 section.

Establishing a serial connection

To establish a serial connection to the console port on the device, complete the following steps.

1. Verify that the device is powered on by verifying that all power LED indicators on the management, interface, power supply, and fan modules display a steady green light.
2. Connect the RJ-45 serial cable provided with the device to the management Ethernet port of the device.

Figure 30: Port-side view of the SLX 9640 Switch Router

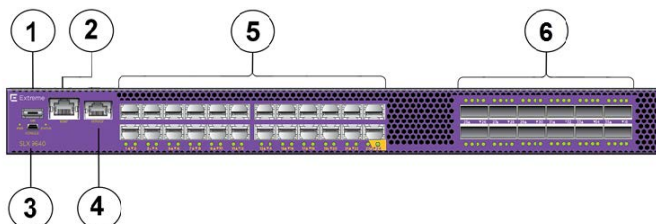

1	USB port
2	1GbE Ethernet Service port
3	Console port (mini-USB)
4	10GbE Ethernet service port
5	1G/10G SFP+ ports (24x)
6	10Gb/25Gb/40Gb/50Gb/100Gb capable QSFP28 ports (12x)

**Note**

The console or serial port is intended primarily for the initial setting of the IP address.

3. Access the device using a terminal emulator application (such as HyperTerminal in a Windows environment or Tip in a UNIX environment).
4. Disable any serial communication programs running on the workstation (such as synchronization programs).
5. Open a terminal emulator application (such as HyperTerminal on a PC, or TERM, Tip, or Kermit in a UNIX environment), and configure the application as follows:
 - In a Windows environment:

Parameter	Value
Bits per second	9600
Data bits	8
Parity	None
Stop bits	1
Flow control	None

**Note**

Flow control is not supported on the serial consoles when attached to remote terminal servers and must be disabled to ensure proper operation.

- In a UNIX environment, enter the following string at the prompt:

```
tip /dev/ttyb -9600
```

If ttyb is already in use, use ttya instead and enter the following string at the prompt:

```
tip /dev/ttya -9600
```

When the terminal emulator application stops reporting information, press **Enter**. You receive the following login prompt:

```
SLX login:
```

- Log in to the console using *admin* as the default login name and *password* as the default password. As login to the device occurs, you are prompted to change the device passwords.

```
Please change passwords for switch default accounts now.
Use Control-C to exit or press 'Enter' key to proceed.
```

- Press **Enter** to step through a procedure to change the passwords as shown in the following example. To skip modifying the password, press **Ctrl+C**.

```
Warning: Access to the Root and Factory accounts may be
required for proper support of the switch. Please ensure the Root
and Factory passwords are documented in a secure location. Recovery of
a lost Root or Factory password will result in fabric downtime.
```

```
for user - admin
Changing password for admin
Enter old password:
Enter new password:
Re-type new password:
passwd: all authentication tokens updated successfully
```

Passwords can be 8 through 40 characters long. They must begin with an alphabetic character. They can include numeric characters, the period (.), and the underscore (_) only. Passwords are case-sensitive, and they are not displayed when you enter them on the command line. For more information on passwords, refer to *Extreme SLX-OS Security Configuration Guide* for the SLX 9640 device.

Configuring a static IP address

Complete the following steps to set a static IP address.



Note

You can also use DHCP to configure a chassis static IP address on the management module.

- Log in to the device using an account that has the admin role.
- Enter global configuration mode using the **configure terminal** command.
- Use the **chassis virtual-ip** command to set the IP address for the chassis.

```
device(config)# chassis virtual-ip 10.20.236.132/20
```

- Use the **ip address** command to set the Ethernet IP address for the management modules. If you are going to use an IPv4 IP address, enter the IP address in dotted decimal notation.

When you have assigned the IP address to management interface 1, you should also assign the IP address to management interface 2 if you have installed a second management module.

```
device(config)# interface Management 1
device(config-Management-1)# no ip address dhcp
device(config-Management-1)# ip address 10.24.85.81/20
```

If you are going to use an IPv6 address, enter the network information in colon-separated notation as prompted after the **ipv6 address** operand.

```
device(config)# interface Management 1
```

```
device(config-Management-1)# no ip address dhcp
device(config-Management-1)# ipv6 address \
fd00:60:69bc:832:e61f:13ff:fe67:4b94/64
```

- Return to privileged EXEC mode by entering **exit**.

```
device(config)# exit
device#
```

- To display the configuration, use the **show running-config interface Management** command.

```
device# show running-config interface Management 1
interface Management 1
no ip address dhcp
ip address 10.24.85.81/20
ipv6 address fd00:60:69bc:832:e61f:13ff:fe67:4b94/64
!
```

Establishing an Ethernet connection

After using a serial connection to configure the IP addresses for the device, you can connect the active management module to the local area network (LAN).



Note

Connecting interface modules to a private network or VLAN is recommended.

After establishing an Ethernet connection, you can complete the device configuration using a serial console connection, Telnet connection, or existing management applications.

Perform the following steps to establish an Ethernet connection to the device.

- Remove the shipping plug from the Ethernet port on the active management module.
The active management module has the LED labeled ACTIVE on the front panel illuminated in blue.
- Insert one end of an Ethernet cable into the Management Ethernet port.

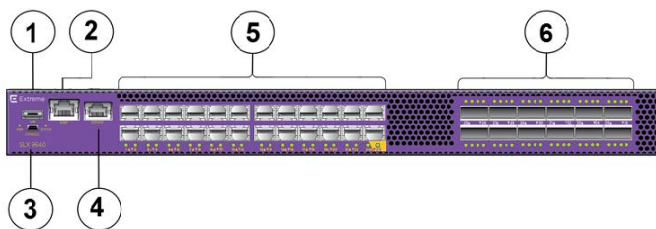

1	USB port
2	1GbE Ethernet Service port
3	Console port (mini-USB)
4	10GbE Ethernet service port
5	1G/10G SFP+ ports (24x)
6	10Gb/25Gb/40Gb/50Gb/100Gb capable QSFP28 ports (12x)

Figure 31: Port-side view of the SLX 9640 Switch Router

3. Connect the other end to 1 G, 100 MbE, or 10 MbE Ethernet LAN.
4. Complete any additional device configuration procedures for the device using one of the following steps:
 - Log in to the device using a serial console connection and admin login.
 - Log in to the device through a Telnet or SSH session using the chassis management IP address and admin login.

Customizing the chassis and host names

To configure a chassis and host name, complete the following task.

The chassis and host names can be up to 30 characters long; can include letters, numbers, hyphens, and underscore characters; and must begin with a letter.

Extreme recommends that you customize the chassis name for each platform because some of the system logs refer to the platform by its chassis name.

1. Log in to the device using one of the following methods:
 - A serial console connection to the active management module. The active management module has the LED labeled ACTIVE on the front panel illuminated in blue.
 - A Telnet session using the chassis management IP address.
2. Log in to the device using *admin* as your login name. If you have not changed the default password, use *password*.
3. Change the chassis name by completing the following steps.
 - a. Enter **configure terminal** to enter global configuration mode.
 - b. Enter **switch-attributes chassis-name** *chassis-name*, where *chassis-name* is the new chassis name.
 - c. Enter **exit** to return to privileged EXEC mode.
 - d. To verify the new chassis name, enter the **show chassis** command.
4. Change the host name by completing the following steps.
 - a. Enter **configure terminal** to enter global configuration mode.
 - b. Enter **switch-attributes host-name** *host-name*, where *host-name* is the new host name.
 - c. Enter **exit** to return to privileged EXEC mode.
 - d. To verify the new host name, enter the **show running-config | include host** command.
5. Record the new names for future reference.

Configuring the DNS service

To view the current DNS configuration, enter the **show ip dns** command. To manually configure a unique domain name for your device, complete the following steps.

- Log in to the device using one of the following methods:
 - A serial console connection to the active management module. The active management module has the LED labeled ACTIVE on the front panel illuminated in blue.
 - A Telnet session using the chassis management IP address.
- Log in to the device using *admin* as your login name. If you have not changed the default password, use *password* for password.
- Enter the **ip dns domain-name** *domain-name* command, where *domain-name* is the domain name for your device.
- (Optional) Enter **ip dns name-server** *ip-address*, where *ip-address* is the IP address of the DNS server.

Setting the date and time

Date and time are used for logging events. The operation of the device does not depend on the date and time; an Extreme device with an incorrect date and time value functions properly. Because the date and time are used for logging, error detection, and troubleshooting, you should set them correctly.

Verifying correct operation

Perform the following steps to verify correct operation of the device.

- Check the LEDs of all power supplies, fans, and modules to verify that all are functional. For a more detailed description of the LEDs on each system component, refer to [Monitoring the Device](#) on page 73 section.
- Log into the device using one of the following methods:
 - A serial console connection to the active management module. The active management module has the LED labeled ACTIVE on the front panel illuminated in blue.
 - A Telnet session using the chassis management IP address.
- Log in to the device using *admin* as your login name. If you have not changed the default password, use *password* for password.
- Verify the correct operation of the device by entering the following commands. Copy output to a file to save the information.

Table 16: Commands to verify correct operation

Command	Description
show environment power	Displays power supply status and information
show environment fan	Displays fans status and information
show chassis or show system	Displays device status and information
show slots	Displays the current status of each slot in the chassis
show environment temp or show environment sensor	Displays temperature status and information

Table 16: Commands to verify correct operation (continued)

Command	Description
show environment history	Displays the history of the installed modules
show history	Displays CLI history
show logging auditlog , and show logging raslog	Displays any errors

Backing up the configuration

Extreme recommends backing up the configuration on a regular basis to ensure that a complete configuration is available for downloading to a replacement device.

Observe the following notes about configuration data:

- Passwords are not saved in the configuration file, and are not uploaded during a configuration upload.
 - It is recommended that the configuration be backed up on a regular basis to ensure that a complete configuration is available for downloading to a replacement chassis.
1. Log in to the device using one of the following methods:
 - A serial console connection to the active management module. The active management module has the LED labeled ACTIVE on the front panel illuminated in blue.
 - A command line interface (CLI) session using the chassis management IP address.
 2. Log in to the device using *admin* as your login name. If you have not changed the default password, use *usepassword*.
 3. Enter **copy running-config { startup-config | flash:// | ftp:// | scp:// | sftp:// | tftp:// | usb:// }**, where:
 - **startup-config** saves the running configuration to the startup configuration.
 - **flash://** saves the running configuration to the flash drive in the specified location.
 - **ftp://** saves the running configuration to the specified FTP server address.
 - **scp://** saves the running configuration to the specified secure copy (SCP) server location.
 - **sftp://** saves the running configuration to the specified Secure FTP (SFTP) server address.
 - **tftp://** saves the running configuration to the specified TFTP server address.
 - **usb://** saves the running configuration to the USB drive attached to the device (for example, plugged into the USB port in the management module).

Installing cable management kit

For more information about installing cable management, refer to managing cables section [Managing cables](#) on page 64.



Transceivers and Cables

- [Supported transceivers and cables on page 63](#)
- [Time and items required on page 63](#)
- [Precautions specific to transceivers and cables on page 64](#)
- [Cleaning the fiber-optic connectors on page 64](#)
- [Managing cables on page 64](#)
- [Installing an SFP+ transceiver on page 65](#)
- [Replacing an SFP+ transceiver on page 67](#)
- [Installing a QSFP28 transceiver on page 68](#)
- [Replacing a QSFP28 transceiver on page 70](#)
- [Breakout cables on page 71](#)
- [Verifying transceiver operation on page 72](#)

Supported transceivers and cables

SLX 9640 device requires QSFP28 optics for 100GbE connectivity, QSFP+ optics for 40GbE connectivity, and 40GbE-to-10GbE breakouts for 10GbE connectivity.

SLX 9640 device requires SFP+ optics for 10GbE connectivity and SFP optics for 1GbE connectivity.

For current information about transceivers and cables that is supported by this device, refer to the *Extreme Ethernet Optics Family Datasheet* on <https://cloud.kapostcontent.net/pub/a070d154-d6f1-400b-b2f0-3d039ae2f604/data-center-ethernet-optics-data-sheet> and to the current *SLX-OS18r.2.00 for ExtremeRouting SLX 9640 Release Notes*.

Time and items required

The installation or replacement procedure for one transceiver takes less than 5 minutes. Ensure that the following items are available:

- Required number of compatible power cables
- Required number of supported Extreme-branded transceivers
- Required number of compatible fiber-optic cables
- Optical transceiver extraction tool (for 10 Gbps transceiver only)



Note

Most Extreme devices come with a transceiver extraction tool and holster. The extraction tool is designed to remove transceivers from modules where the space is limited.

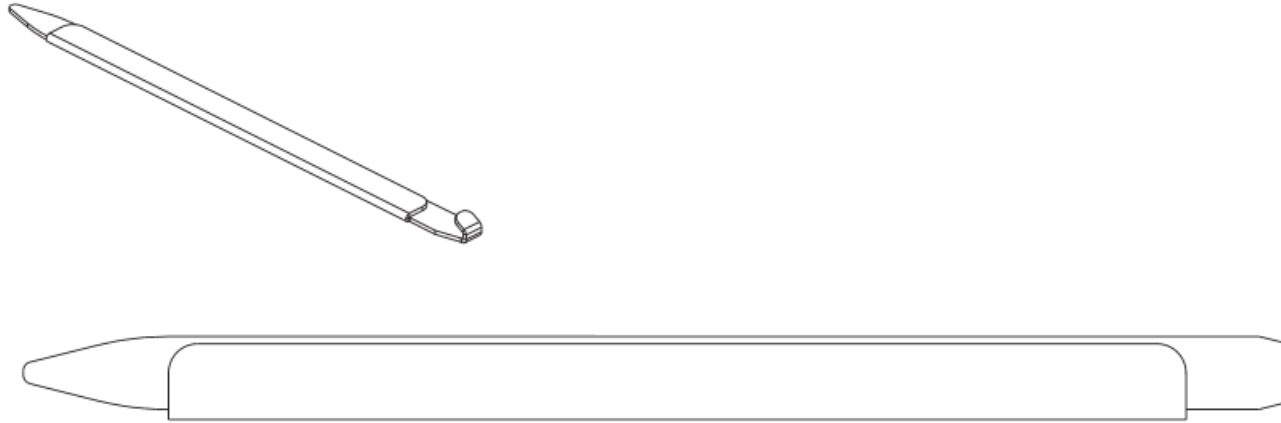

Figure 32: Optical transceiver extraction tool

Precautions specific to transceivers and cables



Warning

All fiber-optic interfaces use Class 1 lasers.



Warning

Use only optical transceivers that are qualified by Extreme Networks, Inc. and comply with the FDA Class 1 radiation performance requirements defined in 21 CFR Subchapter I, and with IEC 60825 and EN60825. Optical products that do not comply with these standards might emit light that is hazardous to the eyes.



Caution

Do not use the port cover tabs to lift the module. They are not designed to support the weight of the module, which can fall and be damaged.



Caution

Before plugging a cable into any port, be sure to discharge the voltage stored on the cable by touching the electrical contacts to ground surface.

Cleaning the fiber-optic connectors

To avoid problems with the connection between the fiber-optic transceiver (SFP+, QSFP, or QSFP28) and the fiber cable connectors, Extreme strongly recommends cleaning both connectors each time you disconnect and reconnect them. Dust can accumulate on the connectors and cause problems such as reducing the optic launch power.

To clean the fiber cable connectors, Extreme recommends using a fiber-optic reel-type cleaner. When not using an SFP+ or QSFP connector, make sure to keep the protective covering in place.

Managing cables

The minimum radius that a 50 micron cable can be bent under full tensile load is 5.1 cm (2 in.). For a cable under no tensile load, that minimum is 3.0 cm (1.2 in.). Cables can be organized and managed in a

variety of ways, for example, using cable channels on the sides of the rack or patch panels to minimize cable management. Following is a list of additional recommendations:

- Plan for rack space required for cable management before installing the device.
- Leave at least 1 m (3.28 ft) of slack for each port cable. This provides room to remove and replace the device, allows for inadvertent movement of the rack, and helps prevent the cables from being bent to less than the minimum bend radius.
- For easier maintenance, label the fiber-optic cables and record the devices to which they are connected.
- Keep LEDs visible by routing port cables and other cables away from the LEDs.
- Do not route the cables in front of air vents.
- Use Velcro[®] type straps to secure and organize fiber-optic cables.
- Route the cables away from LEDs to keep them visible.
- Use the cable management comb that attaches to the chassis for simple cable management. The comb can be installed without service disruption.

**Caution**

Before plugging a cable into any port, be sure to discharge the voltage stored on the cable by touching the electrical contacts to ground surface.

**Note**

Do not use tie wraps with optical cables because they are easily overtightened and can damage the optic fibers.

Installing an SFP+ transceiver

While non-Extreme optics are supported, Extreme-qualified transceivers are recommended. The port might not become operational using unqualified transceivers.

To insert an SFP+ transceiver, complete the following steps.

**Note**

Route cables to the side so that the line cards can be removed without disturbing the cables to the other line cards.

**Note**

Always use the pull tab to insert or remove transceivers as they might be hot.

1. Perform one of the following steps, depending on your transceiver type.
 - If the transceiver uses a pull tab, use the pull tab to help push the transceiver into the port until it is firmly seated and the latching mechanism clicks.

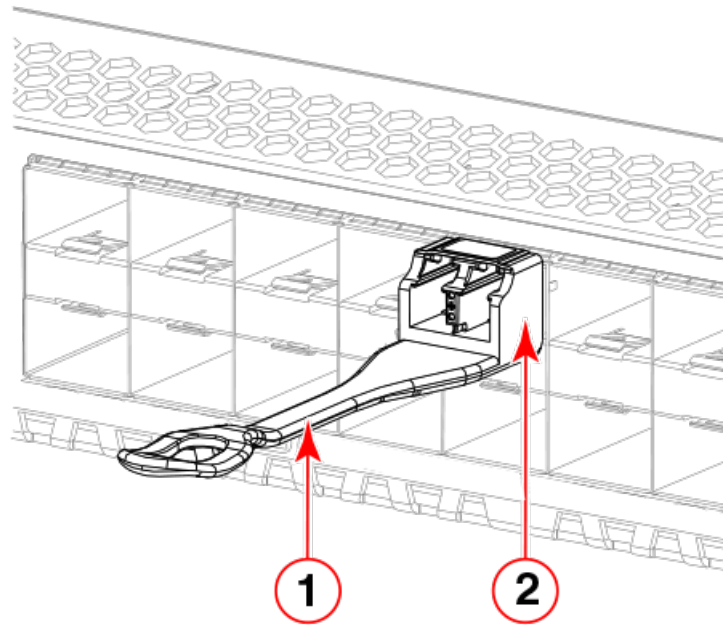

- a. Pull tab
- b. Transceiver

Figure 33: Installing an SFP+ transceiver with pull tab into the interface module port

- If the transceiver uses a bail latch mechanism (10 GbE transceivers only), ensure that the bail (wire handle) is in the unlocked position, grasp the transceiver, and push it into the port until firmly seated. Close the bail to latch the transceiver in the slot.

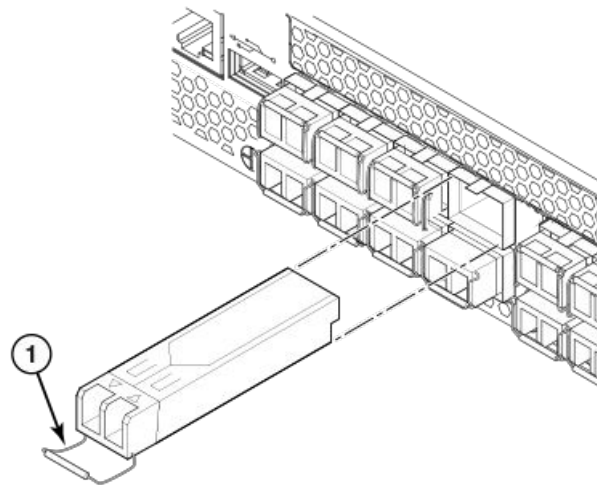

- a. Bail

Figure 34: Installing an SFP+ transceiver with bail latch into the interface module port

Transceivers are keyed so that they can only be inserted with the correct orientation. If a transceiver does not slide in easily, ensure that it is correctly oriented.

- Position a cable so that the key (the ridge on one side of the cable connector) is aligned with the slot in the transceiver. Insert the cable into the transceiver until the latching mechanism clicks.



Note

Cables are keyed so that they can be inserted in only one way. If a cable does not slide in easily, ensure that it is correctly oriented. Do not insert any unsupported cable intended for an other type of transceiver into a regular SFP+ transceiver. You may damage the cable as well as the transceiver.

Replacing an SFP+ transceiver

Complete the following steps to remove and then install a new SFP+ transceiver.

- Remove any cables that are inserted into the transceiver.
- To remove the transceiver, perform one of the following steps, depending on your transceiver type.
 - If transceiver has a bail latch mechanism (10 GbE transceivers), unlatch from the port by pulling the bail (wire handle) away from its pivot point using your fingers or the hooked end of the transceiver extraction tool. Pull the transceiver out from the port slightly using the bail, and then grasp the transceiver with your fingers and slide it straight out of the port.

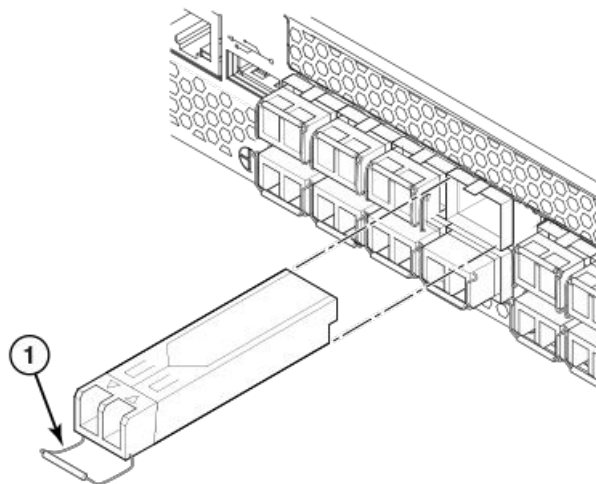

a. Bail

Figure 35: Installing an SFP+ transceiver with bail latch into the interface module port

- If transceiver has a pull tab, grasp the pull tab and pull the transceiver straight out from the port.



Note

Grasp the pull tab near the body of the transceiver to reduce the chances of bending the pull tab. As the transceiver may be hot, avoid touching it.

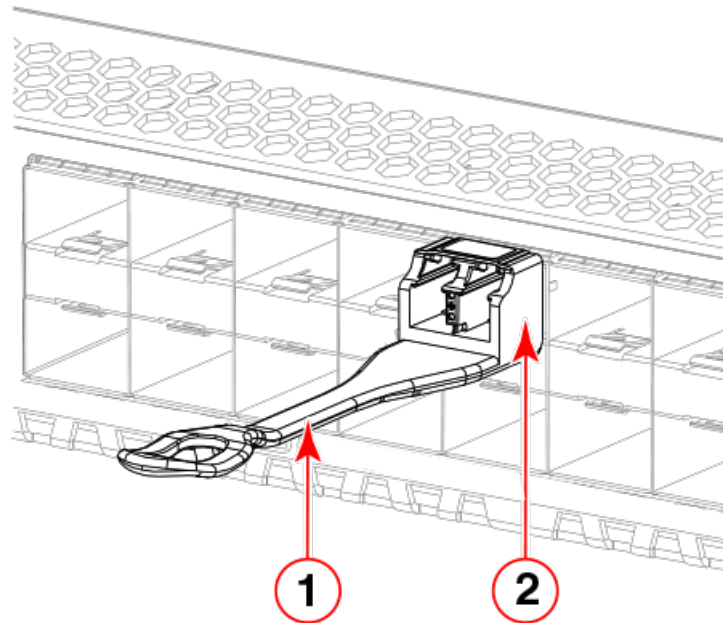

- a. Pull tab
- b. Transceiver

Figure 36: Replacing a SFP+ optical transceiver with pull tab into the interface module port

3. To install the transceiver, perform one of the following steps depending on your transceiver type:
 - If transceiver has a pull tab, use the pull tab to help push the transceiver into the port until it is firmly seated and the latching mechanism clicks.
 - If transceiver has a bail latch mechanism, ensure that the bail (wire handle) is in the unlocked position, grasp the transceiver, and push it into the port until firmly seated. Close the bail to latch the transceiver in the slot.

Transceivers are keyed so that they can only be inserted with the correct orientation. If a transceiver does not slide in easily, ensure that it is correctly oriented.

4. Position a cable so that the key (the ridge on one side of the cable connector) is aligned with the slot in the transceiver. Insert the cable into the transceiver until the latching mechanism clicks.

Cables are keyed so that they can be inserted in only one way. If a cable does not slide in easily, ensure that it is correctly oriented.

Installing a QSFP28 transceiver

While non-Extreme optics are supported, Extreme-qualified transceivers are recommended. The port might not become operational or it may have a higher error rate using unqualified transceivers.

The following additional notes apply to the QSFP28 transceivers:

- While non-Extreme optics are supported, Extreme-qualified transceivers are recommended.
 - If using 40GbE-to-10GbE breakouts, each QSFP28 transceiver contains four individual 10 GbE ports. Be aware that any problems with one port could affect all four ports in the quad if the QSFP28 must be replaced.

- Some QSFP28 transceivers have an integrated cable attached. You do not need to install a separate cable.

To insert an QSFP28 transceiver and cable, complete the following steps.

1. Push the transceiver into the port using the pull tab. Transceivers are keyed so that they can only be inserted with the correct orientation. If a transceiver does not slide in easily, ensure that it is correctly oriented. Push the correctly oriented transceiver into the port until it is firmly seated and the latching mechanism clicks.



Note

Always use the transceiver pull tab to insert or remove the QSFP28 transceivers, as the transceiver might be hot.

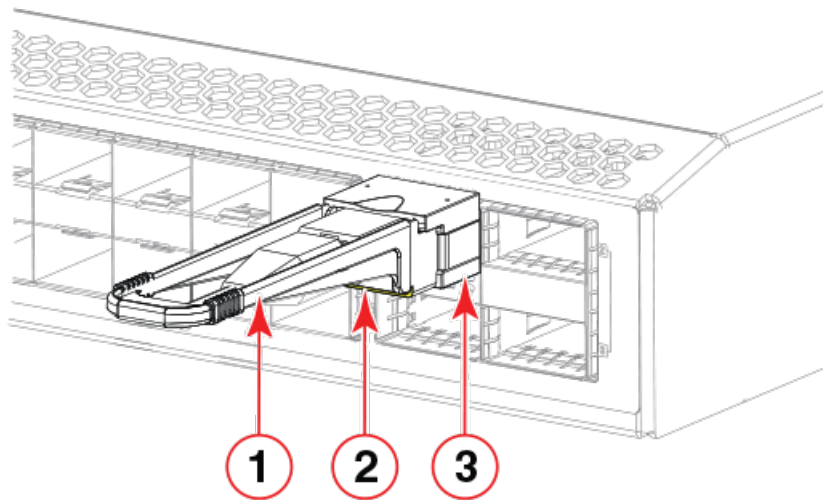

- a. Pull tab
- b. QSFP28 cable
- c. QSFP28 transceiver

Figure 37: Installing a QSFP28 transceiver into the interface module port

After insertion, the LEDs have the following status:

- Off - no link
- On - link, no traffic
- Rapid flash - link with traffic
- Slow flash (one second on, one second off) - beaconing feature

2. Position the cable so that the key (the ridge on one side of the cable connector) is aligned with the slot in the transceiver. Insert the cable into the transceiver until the latching mechanism clicks.

**Note**

If your transceiver has an integrated cable, you do not need to install a cable.

**Note**

Cables are keyed so that they can be inserted in only one way. If a cable does not slide in easily, ensure that it is correctly oriented. Do not insert any unsupported cable intended for another type of transceiver into a regular QSFP28 transceiver. You may damage the cable as well as the transceiver.

3. Organize cables to avoid covering LEDs and air vents so that LCs can be removed. Refer to [Managing cables](#) on page 64 for more information.

Replacing a QSFP28 transceiver

Complete the following steps to remove and then install a new QSFP28 transceiver.

1. Remove any cables that are inserted into the transceiver.

**Note**

If your transceiver has an integrated cable, you cannot remove the cable.

2. Grasp the transceiver pull tab and gently pull the transceiver straight out from the port.

**Note**

Grasp the pull tab near the body of the transceiver to reduce the chances of bending the pull tab. As the transceiver may be hot, always use the pull tab and avoid touching the transceiver body.

3. To insert the replacement transceiver, use the pull tab to carefully push the transceiver into the port. Transceivers are keyed so that they can only be inserted with the correct orientation. If a transceiver does not slide in easily, ensure that it is correctly oriented. Gently push the correctly oriented QSFP28 transceiver until the latching mechanism clicks.

**Note**

The following figure uses a generic interface module. Your interface module might look different.

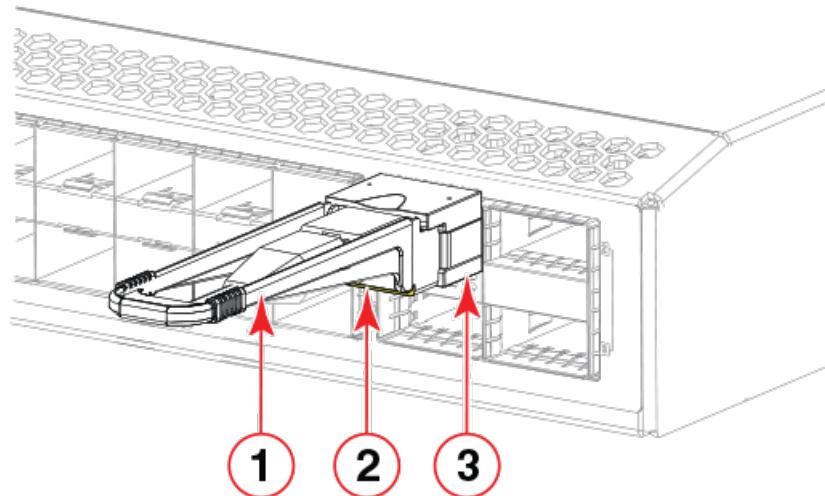

- a. Pull tab
- b. QSFP28 cable connector
- c. QSFP28 transceiver

Figure 38: Replacing a QSFP28 optical transceiver into blade port

4. Position a cable so that the key (the ridge on one side of the cable connector) is aligned with the slot in the transceiver. Insert the cable into the transceiver until the latching mechanism clicks.



Note

If your transceiver has an integrated cable attached, you will not install a cable.

When both ends of the cable are inserted and the link is fully established, the LED displays steady green.



Note

Cables are keyed so that they can be inserted in only one way. If a cable does not slide in easily, ensure that it is correctly oriented.

5. Organize cables to avoid covering LEDs and air vents. Refer to [Managing cables](#) on page 64 for more information.

Breakout cables

The copper breakout cables are terminated with optical connectors and are available in 1m, 3m, 5m, and greater lengths. No additional connectors or cabling are required when using the copper breakout. When using the fiber breakout cables, additional 10Gb optics are required.

For the SLX 9640 device interfaces 0/25 to 0/36 support up to 48 10GbE or 48 25GgE ports in breakout mode by using the following optics:

For 4 x 10Gbe breakout:

- 4 SFP+ 40GbE-to-10GbE copper breakout cables in 1m, 3m, or 5m or greater lengths.
- 40G-QSFP-SR4-INT (with fiber breakout cables and additional 10GbE optics).

- 40G-QSFP-ESR4 (with fiber breakout cables and additional 10GbE optics).

For 4x 25GbE breakout:

- 100G-QSFP-4SFP-P-XXX

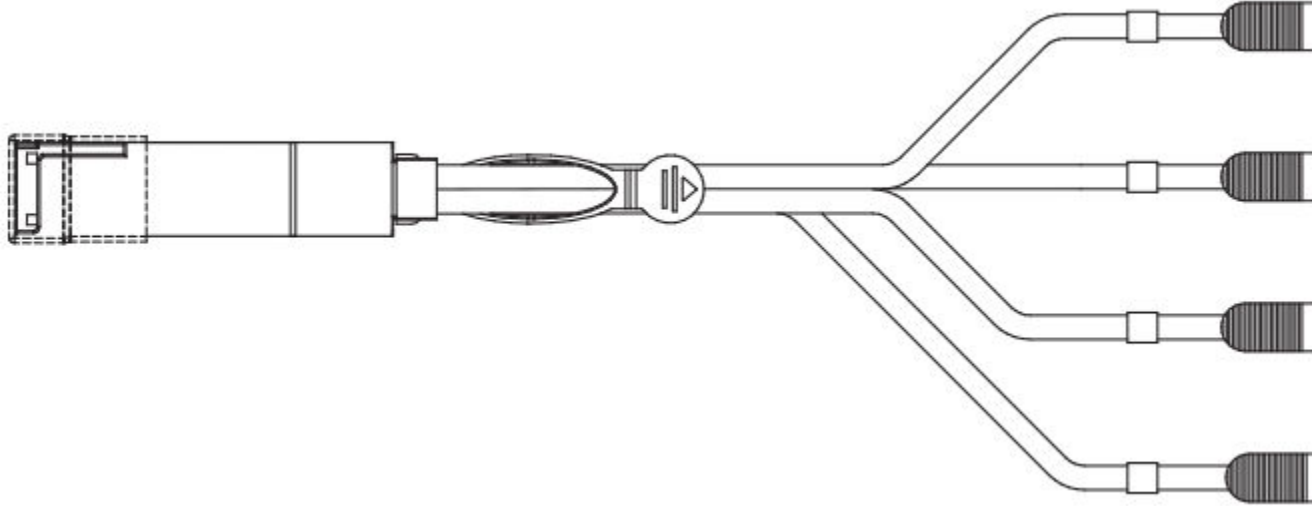

Figure 39: QSFP+ to 4 SFP+ (4 x 10 GbE) direct-attach copper breakout cable

Verifying transceiver operation

To verify operation of a transceiver, view the LEDs on the transceiver. To find the LED locations on the interface modules, refer to [LED activity interpretation](#) on page 73. After you have connected and configured the ports for Ethernet connectivity and connected the cable to another active port, the LED becomes solid green. When traffic is detected on the port, the light becomes blinking green.

You can also enter the **show interface status** and **show ip interface brief** commands to verify proper transceiver operation.



Monitoring the Device

[Monitoring Overview](#) on page 73

[LED activity interpretation](#) on page 73

[LED indicators](#) on page 74

Monitoring Overview

The Extreme device is engineered for reliability and requires no routine operational steps or maintenance. You can monitor the device by paying attention to the following information:

- The LEDs showing the status of system components
- A description of the operations that the device performs when you power it on

The following commands can be especially helpful in monitoring the health status of various device components. For details about these commands, refer to the *Extreme SLX-OS Monitoring Configuration Guide* for the SLX 9640 device.

- **show chassis**
- **show system**
- **show slots**
- **show linecard**
- **show environment fan**
- **show environment power**
- **show environment sensor**
- **show environment temp**

LED activity interpretation

The SLX 9640 switch router has the following LEDs on the front panel:

- One power single-color status LED (green)
- One status bicolor status LED (green and amber)
- One fan bicolor status LED (green and amber)
- One PSU bicolor status LED (green and amber)

The figure below shows the LEDs on the SLX 9640 switch router front panel.

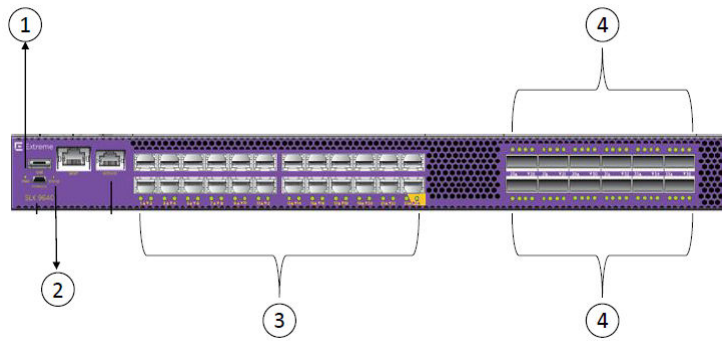

Figure 40: SLX 9640 switch router LEDs

1. Power LED
2. Status LED
3. Status Port LEDs SFP+ ports (1G/10G) ports
4. Status LEDs for QSFP ports

LED indicators

The SLX 9640 device LED indicators are as follows:

- The Power/Status LEDs are visible to the front panel
- The Ethernet LEDs are integrated with the RJ45 connector
- The Power supply LEDs are integrated with the PSU
- The 10G and 100G Port LEDs are surface mount types. They are visible to the front panel

The Table below shows the LEDs Indications on the SLX 9640 device.

Table 17: SLX 9640 device LED Indications

LED Function/state	Meaning	Possible cause
<i>Power</i>		
Off	No power	Some Power rails are dropping below specification
Green	Valid power. All monitored voltages are nominal	
<i>Status (bicolor)</i>		
Blinking Amber-Green	Attention	TBD by SW
Amber	Fault/ initial state	This LED shall be lit during the reboot
Green	Board is operational	
<i>1G Ethernet Status</i>		

Table 17: SLX 9640 device LED Indications (continued)

LED Function/state	Meaning	Possible cause
Management port link LED OFF ON	Indicates port link status Not cabled A link is up	The Ethernet LEDs are integrated with the RJ45 connector and are driven by the respective Ethernet Phys.
Management port speed LED ON OFF	Indicates port speed status Link is up in 1 GbE mode Link is up in 100 Mbps mode, or 10 Mbps mode, or no link	
<i>Power Supply Input Status (On PSU)</i>		
Off	Unit is OFF or FAULT condition	- Input Voltage is Above over voltage range or Below under voltage range - No input Power present
Green Blinking	OV/UV warning	Input voltage is in OV or UV warning range
Green Steady	OK	Input voltage is nominal.
<i>Power Supply Output Status (On PSU)</i>		
Off	No Power	
Green Blinking	Stand-By	Standby output enabled with no power supply warning or fault detected
Green Steady	Power GOOD	Main output and standby output enabled with no power supply warning or fault detected
Amber Blinking	Warning	Power supply warning detected as per PMBus STATUS_X reporting bytes
Amber Steady	FAULT	Power supply fault detected as per PMBus STATUS_X reporting bytes
<i>Fan Status LED (On Fan FRU)</i>		
Off (no light)	No Power	
Green Steady	Fan operates per specification (Normal)	
Amber Steady	Fan needs attention/ replacement	
<i>10G/100G Port LEDs (Green only)</i>		
Solid Off	No Link	
Solid ON	Link, no traffic	Mismatched airflow fan or fan runs below setting speed.
Green Flicker	Link, traffic	Activities

Table 17: SLX 9640 device LED Indications (continued)

LED Function/state	Meaning	Possible cause
All LEDs (and the chassis LED) On 1 sec, Off 1 sec	Chassis Beacons	
One port LED on 2 sec, Off 2 sec	Indicates a particular port fault.	
<i>Home Run Port LEDs (Amber only. Note: This LED is shared with SFP Port 24 LED)</i>		
Solid Off	No Link	
Solid Amber ON	Link, no traffic	
Amber Flicker	Link, Activity	



Power Supplies

- [Power supply overview on page 77](#)
- [Precautions specific to power supplies on page 79](#)
- [Identifying the airflow direction on page 80](#)
- [Time and items required on page 80](#)
- [Replacing a power supply on page 80](#)
- [Inserting a new AC power supply on page 81](#)
- [Inserting a new DC power supply on page 82](#)
- [Grounding the SLX 9640 device on page 85](#)

Power supply overview

The ExtremeRouting SLX 9640 device supports alternating-current (AC) and direct-current (DC) power supplies. The SLX 9640 device is capable of running on one power supply and five fan assemblies. The second power supply and sixth fan assembly provide redundancy.

If the second power supply and sixth fan assembly slots are unused, you must cover them with filler panels.



Note

Extreme Networks recommends that the SLX 9640 device operate with two power supplies and six fan assemblies installed. If a power supply or fan assembly fails, it must be replaced as soon as possible.



Note

AC and DC power supplies can be installed and used in the same device.

The power supplies in the SLX 9640 device chassis can be removed and replaced without special tools. The device can continue operating during the replacement.

The device supports the following types of power supplies:

- AC power supply with nonport-side air exhaust. This unit moves the air from the port-side to the nonport-side of the device.
- AC power supply with nonport-side air intake. This unit moves the air from the nonport-side to the port-side of the device.

- DC power supply with nonport-side air exhaust. This unit moves the air from the port-side to the nonport-side of the device.
- DC power supply with nonport-side air intake. This unit moves the air from the nonport-side to the port-side of the device.

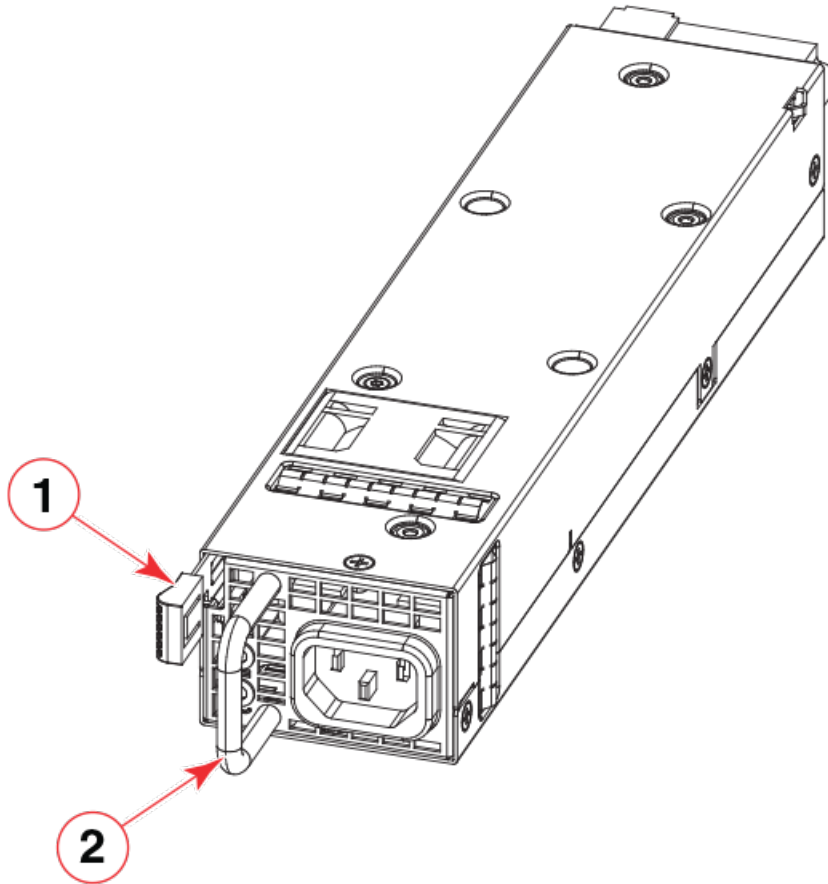

1. Release lever
2. Power supply handle

Figure 41: AC power supply

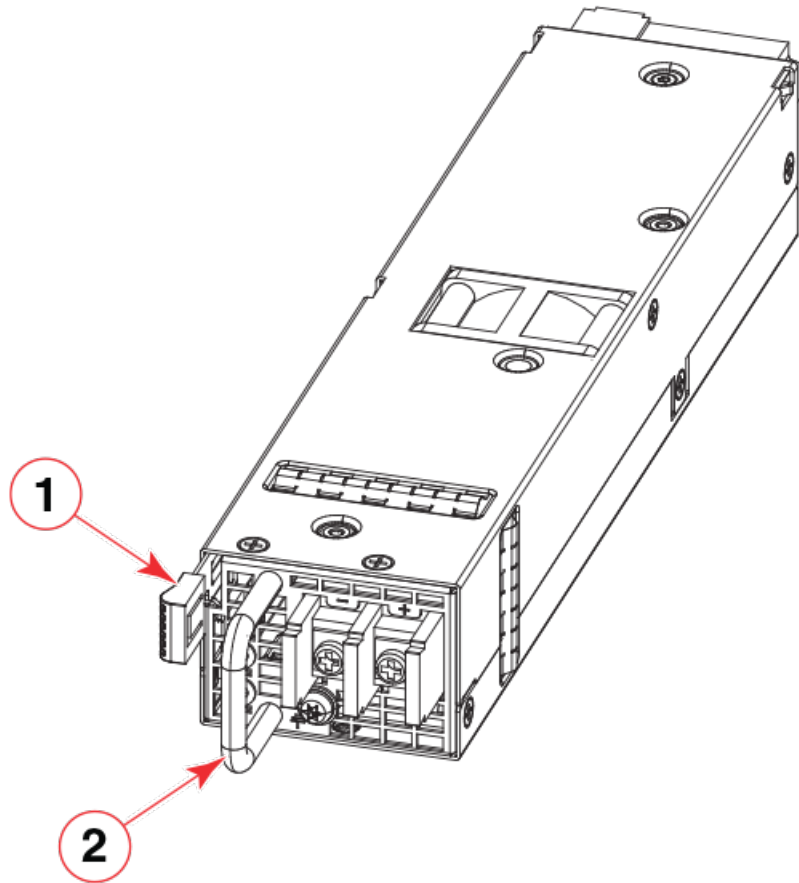

Figure 42: DC power supply

1. Release lever
2. Power supply handle

Precautions specific to power supplies



Warning

Make sure that the power source circuits are properly grounded, then use the power cord supplied with the device to connect it to the power source.



Warning

If the installation requires a different power cord than the one supplied with the device, make sure you use a power cord displaying the mark of the safety agency that defines the regulations for power cords in your country. The mark is your assurance that the power cord can be used safely with the device.



Caution

Disassembling any part of the power supply and fan assembly voids the warranty and regulatory certifications. There are no user-serviceable parts inside the power supply and fan assembly.

**Caution**

Ensure that the airflow direction of the power supply unit matches that of the installed fan tray. The power supplies and fan trays are clearly labeled with either a green arrow with an "E", or an orange arrow with an "I."

**Caution**

If you do not install a module or a power supply in a slot, you must keep the slot filler panel in place. If you run the chassis with an uncovered slot, the system will overheat.

Identifying the airflow direction

The power supply and fan assemblies are identified by the following airflow directions:

- **Intake power supply and fan assembly with an orange "I" label or without any label:** Pulls air from the nonport-side of the switch and exhausts it out the port side.

	<ul style="list-style-type: none"> ◦ Nonport-side air intake ◦ Port-side air exhaust ◦ Back-to-front (nonport-side to port-side) airflow ◦ Part numbers ending with -R
---	--

- **Exhaust power supply and fan assembly with a green "E" label:** Pulls air from the port side of the switch and exhausts it out the nonport-side.

	<ul style="list-style-type: none"> ◦ Nonport-side air exhaust ◦ Port-side air intake ◦ Front-to-back (port-side to nonport-side) airflow ◦ Part numbers ending with -F
---	--

Time and items required

Installing or removing and replacing a power supply should require less than five minutes to complete.

A new power supply (with the same airflow direction as the power supply being replaced) is required to replace a power supply.

The following items are required for the power supply replacement:

- New power supply unit or filler panel
- #2 Phillips screwdriver

Replacing a power supply

When installing or replacing a power supply unit, keep in mind the following:

- Power supplies can be swapped in or out while the device is running. The remaining power supply provides enough power for the device.

- The airflow direction of the power supply must match that of the installed fan assemblies. All must be either exhaust or intake.

**Note**

Power supplies are hot-swappable. However, they should be inserted or removed without a power cord being connected to a power source to avoid damage.

**Caution**

Ensure that the airflow direction of the power supply unit matches that of the installed fan tray. The power supplies and fan trays are clearly labeled with either a green arrow with an "E", or an orange arrow with an "I."

Inserting a new AC power supply

Use the following steps to install an AC power supply in the SLX 9640 device.

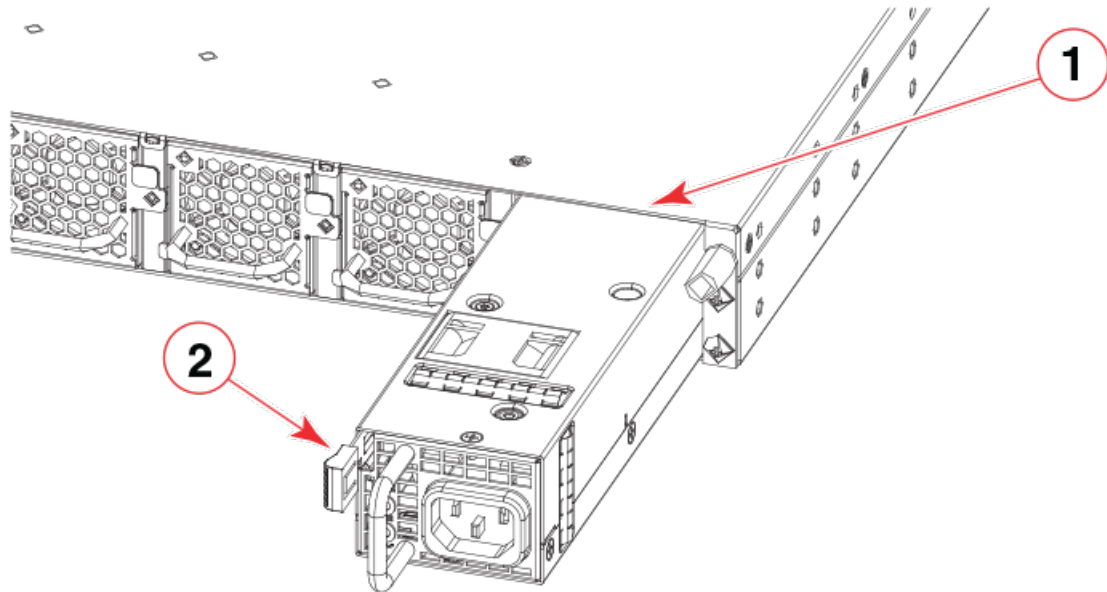

1. Power supply slot
2. Release lever

Figure 43: Installing an AC power supply unit

1. If replacing a power supply, remove the previously installed power supply from the appropriate slot by pressing the release lever and pulling the power supply handle.
2. If installing a new power supply into a slot covered with a filler panel:
 - a. Press the release lever on the filler panel.
 - b. Remove the filler panel.
3. Before opening the package that contains the power supply, touch the bag to the switch casing to discharge any potential static electricity. Extreme recommends using an ESD wrist strap during installation.
4. Remove the power supply from the anti-static shielded bag.

5. Holding the power supply level, guide it into the carrier rails on each side and gently push it all the way into the slot, ensuring that it firmly engages with the connector and the release lever clicks into its locked position.

When the SLX 9640 device is powered on, the LEDs on the power supply rear panel should light up green to confirm that the power supply is correctly installed and supplying power.

**Note**

If you do not install a power supply in a slot, you must keep the slot filler panel in place. If you run the device with an uncovered slot, the system will overheat.

Inserting a new DC power supply

**Caution**

All devices with DC power supplies are intended for installation in restricted access areas only. A restricted access area is a location where access can be gained only by trained service personnel through the use of a special tool, lock and key, or other means of security, and is controlled by the authority responsible for the location.

**Note**

This equipment installation must meet NEC/CEC code requirements. Consult your local authorities for required regulations

Use the following steps to install an DC power supply in the SLX 9640 device.

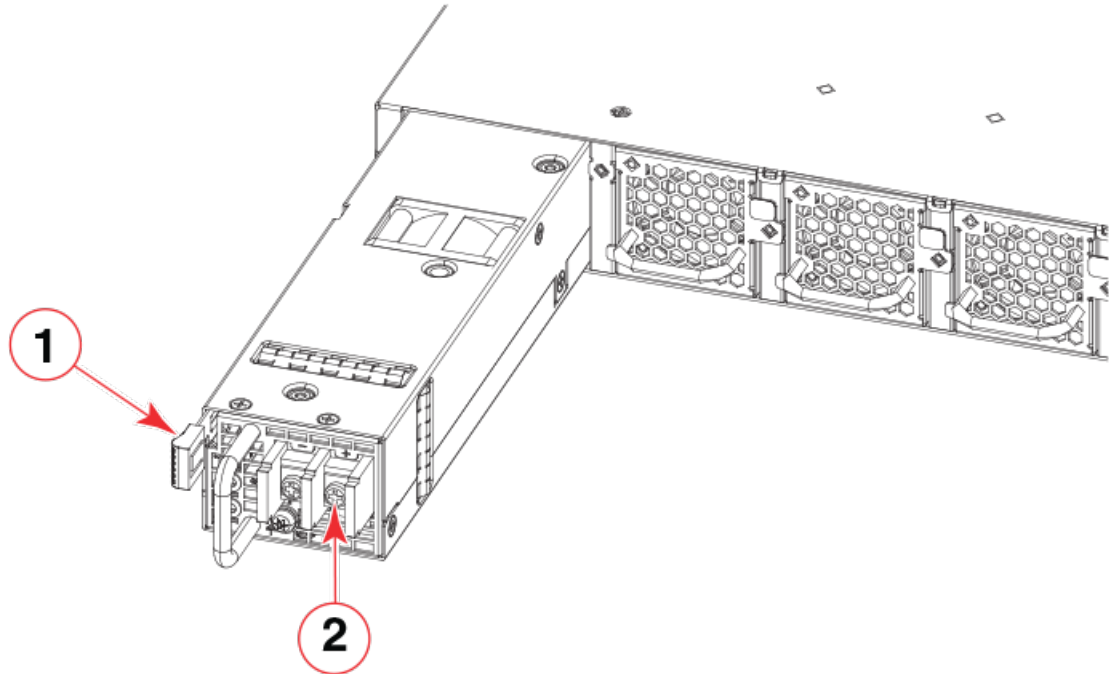

1. DC power supply terminals
2. Safety ground screw

Figure 44: Installing an DC power supply unit

1. Make sure that power is disconnected at the circuit breaker before proceeding.
2. Prepare the power and safety grounding wires using the appropriate size wire, crimp on ring lugs and heat shrink tube for all three wires. Due to the limited space for the safety ground wire, we recommend using a 90 angled lug such as:
 - TE Connectivity Solistrand "16-14HD 90 Ring 8", part number 184269-1 for 14 AWG wire
 - PIDG 12-10 Ring #8, 90-DEG, part number 1958340-1 for 12 or 10 AWG wire
3. Remove the previously installed power supply from the appropriate slot by pressing the release lever and pulling the power supply handle.
4. Before opening the package that contains the DC power supply, touch the bag of the switch casing to discharge any potential static electricity. It is recommended to use an ESD wrist strap during installation.
5. Remove the DC power supply from the anti-static shielded bag.
6. Remove the DC terminals plastic cover.
7. Attach the safety grounding wire to the power supply using the safety ground screw.

8. Attach the DC power supply wires to the power supply DC power terminals, matching the polarity. Refer to Figure 46.

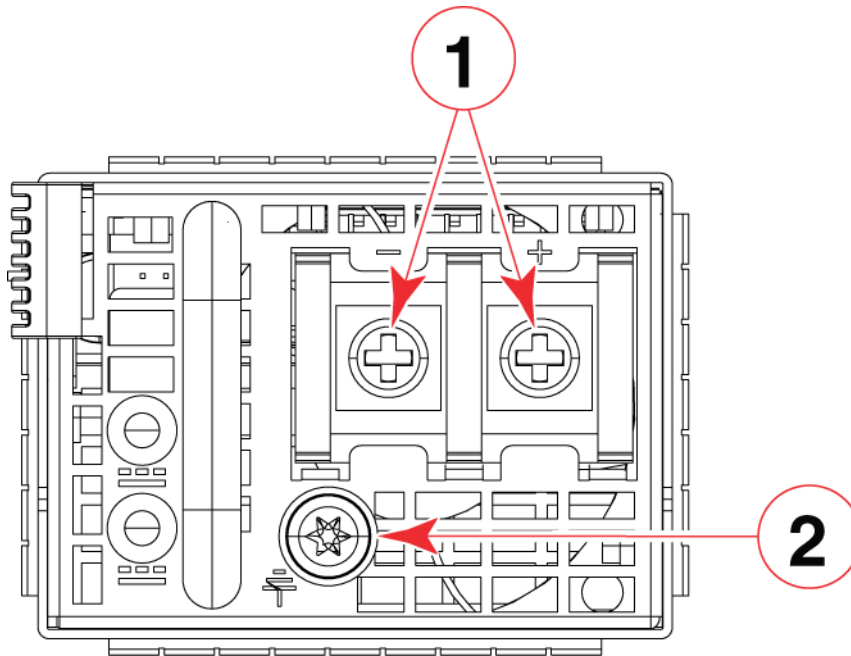

- 1 - DC power terminals
- 2 - Safety ground screw

Figure 45: DC power supply wiring terminals

9. Make sure the screws are tight with no wire touching the ground screw. Refer to the Figure below for an example of a suitable wiring.

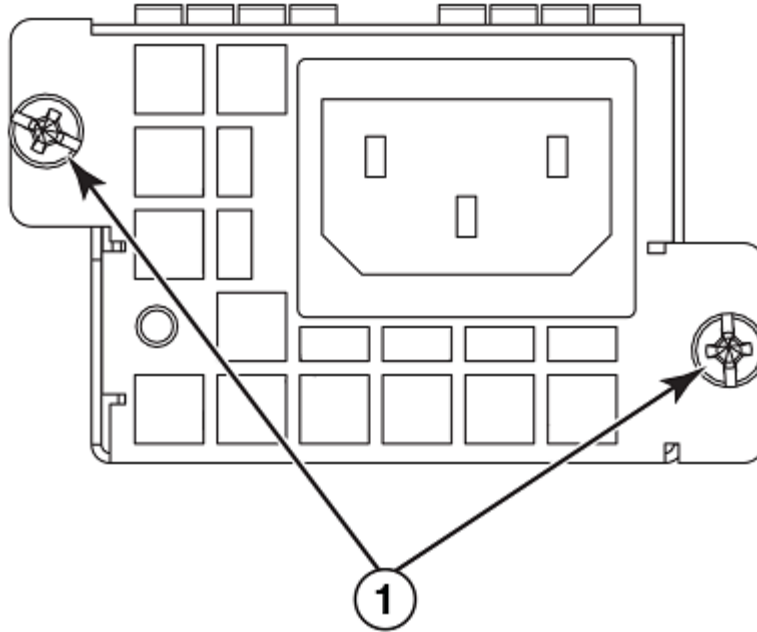

- a. DC, power wires
- b. Safety ground wire

Figure 46: Example of a suitable wiring (TO BE REPLACED)

10. Using the handle on the power supply, hold the power supply level and guide it into the power supply slot. Gently push the power supply all the way into the slot, ensuring that it firmly engages with the connector and the release lever clicks into its locked position.

When the SLX 9640 device is powered on, the power LED on the front of the device should turn green to confirm that the power supply is correctly installed and supplying power. Refer to [LED activity interpretation](#) on page 73.

Grounding the SLX 9640 device

The rear panel of the SLX 9640 device includes a dual-screw grounding terminal. The surface area around this terminal is not painted to provide a good electrical connection. Before connecting power to the device, the grounding terminal must be connected to ground to ensure proper operation and to meet electromagnetic interference (EMI) and safety requirements.

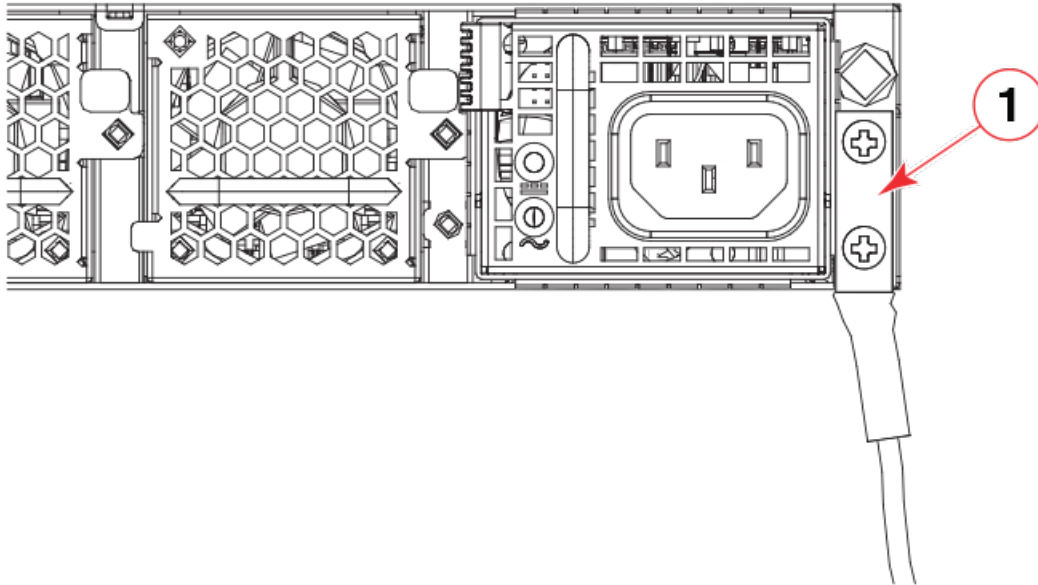

1. Grounding terminal

Figure 47: Connecting the grounding terminal



Note

The grounding lug must be sized according to NEC/CEC requirements. A typical installation would require:

1. Lug, copper, suitable wire size, #10 2-hole, 5/8" centers. For #10 ga. Wire, example lugs are:
 - Panduit LCD10-10AF-L
 - Pencom EL1244
 - Hardware Specialties 912302
2. Screw, 10-32, 1/2", qty 2
3. Washer, #10, external locking, qty 2

Perform the following steps to connect to the grounding terminal.

1. Ensure that the rack in which the SLX 9640 device is mounted is properly grounded and in compliance with local regulations.
2. Ensure that there is a good electrical connection to the grounding point on the rack (no paint or isolating surface treatment).
3. Crimp the included grounding lug to a grounding wire of at least 12 American Wire Gauge (AWG). The 12 AWG wire and grounding lug should be crimped together using a proper tool.
4. Attach the 12 AWG stranded copper wire to the grounding terminal on the SLX 9640 device using the screws included in the grounding kit.
5. Attach the grounding wire to a grounding point.



Note

The terminal for the connection of a grounding conductor is not to be used with an aluminum conductor.



Fan Assemblies

[Fan assembly overview on page 87](#)

[Precautions specific to fan assemblies on page 88](#)

[Identifying the airflow direction on page 89](#)

[Times and items required on page 89](#)

[Replacing a fan assembly on page 89](#)

[Inserting a new fan assembly on page 90](#)

Fan assembly overview

The ExtremeRouting SLX 9640 device includes six redundant, hot-swappable fan units. However, the switch is capable of running on one power supply and five fans. The second power supply and sixth fan provide redundancy.

If the second power supply and sixth fan slots are unused, you must cover them with filler panels.



Note

Extreme Networks recommends that the SLX 9640 device operate with two power supplies and six fan assemblies installed. If a power supply or fan assembly fails, it must be replaced as soon as possible.

The fan assemblies in the SLX 9640 device chassis can be removed and replaced without special tools. The device can continue operating during the replacement.

The device supports the following types of fan assemblies:

- Fan assembly with nonport-side air exhaust. This unit moves the air from the port-side to the nonport-side of the device.
- Fan assembly supply with nonport-side air intake. This unit moves the air from the nonport-side to the port-side of the device.

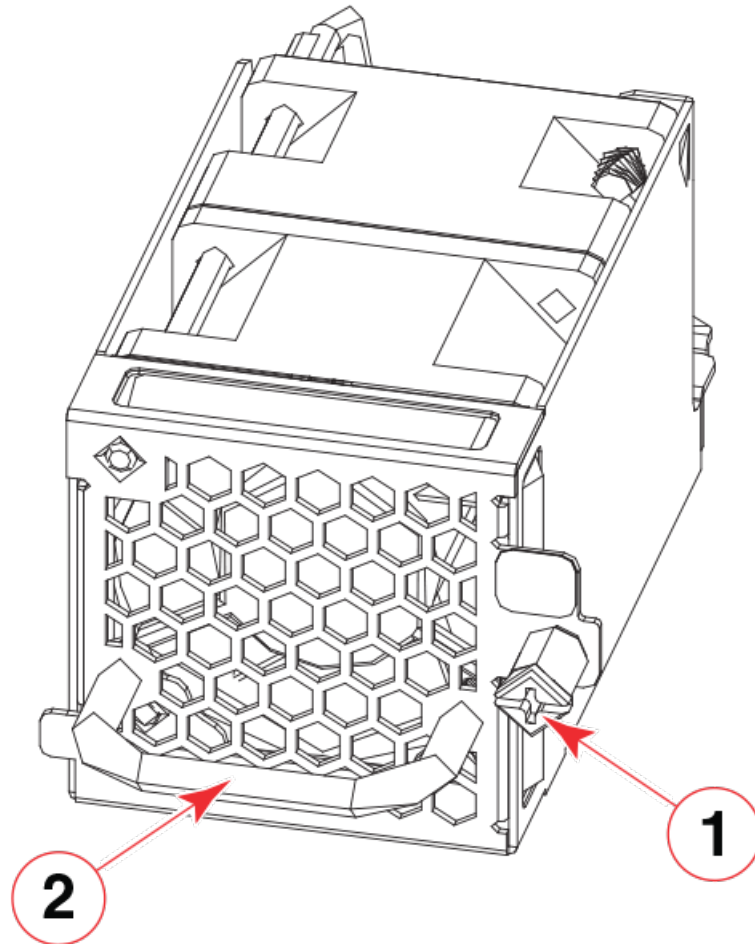

1. Captive screw
2. Fan assembly handle

Figure 48: Fan assembly

Precautions specific to fan assemblies



Warning

Be careful not to accidentally insert your fingers into the fan tray while removing it from the chassis. The fan may still be spinning at a high speed.



Caution

Disassembling any part of the power supply and fan assembly voids the warranty and regulatory certifications. There are no user-serviceable parts inside the power supply and fan assembly.



Caution

Ensure that the airflow direction of the power supply unit matches that of the installed fan tray. The power supplies and fan trays are clearly labeled with either a green arrow with an "E", or an orange arrow with an "I."

**Caution**

If you do not install a module or a power supply in a slot, you must keep the slot filler panel in place. If you run the chassis with an uncovered slot, the system will overheat.

Identifying the airflow direction

The power supply and fan assemblies are identified by the following airflow directions:

- **Intake power supply and fan assembly with an orange "I" label or without any label:** Pulls air from the nonport-side of the switch and exhausts it out the port side.

	<ul style="list-style-type: none"> ◦ Nonport-side air intake ◦ Port-side air exhaust ◦ Back-to-front (nonport-side to port-side) airflow ◦ Part numbers ending with -R
---	---

- **Exhaust power supply and fan assembly with a green "E" label:** Pulls air from the port side of the switch and exhausts it out the nonport-side.

	<ul style="list-style-type: none"> ◦ Nonport-side air exhaust ◦ Port-side air intake ◦ Front-to-back (port-side to nonport-side) airflow ◦ Part numbers ending with -F
--	---

Times and items required

Installing or removing and replacing a fan assembly should require less than five minutes to complete.

The following items are required to replace a fan assembly:

- New fan assembly (must have the same airflow direction as the fan assembly being replaced)
- #1 Phillips screwdriver

Replacing a fan assembly

When installing or replacing a fan assembly unit, keep in mind the following:

- Fan assemblies can be swapped in or out while the device is running. The remaining fan assemblies provide enough airflow for the device.

- The airflow direction of the fan assembly must match that of the installed fan trays. All must be either exhaust or intake.



Caution

Ensure that the airflow direction of the power supply unit matches that of the installed fan tray. The power supplies and fan trays are clearly labeled with either a green arrow with an "E", or an orange arrow with an "I."

Inserting a new fan assembly

Use the following steps to install a fan assembly in the SLX 9640 device.

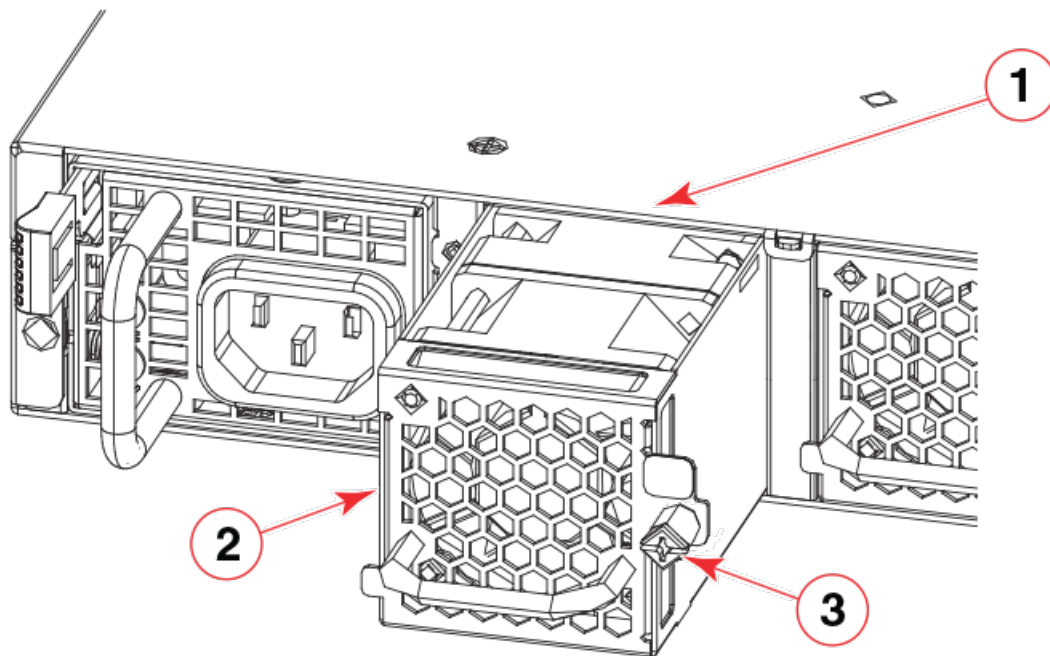

- Fan assembly slot
- Fan assembly
- Captive screw

Figure 49: Installing a fan assembly

- If replacing a fan assembly:
 - Using a Phillips screwdriver, unscrew the captive screw on the fan assembly.
 - Remove the fan assembly from the chassis by pulling the handle on the fan assembly out and away from the chassis.
 - Ensure that the replacement fan assembly has the same part number and airflow label as the fan assembly being replaced.
- If installing a new fan assembly into a slot covered with a filler panel:
 - Using a Phillips screwdriver, unscrew the captive screw on the filler panel.
 - Remove the filler panel.
- Before opening the package that contains the new fan assembly, touch the bag to the switch casing to discharge any potential static electricity. It is recommended that you wear an ESD wrist strap during installation.

4. Remove the fan assembly from the anti-static shielded bag.

**Note**

Do not force the installation. If the fan assembly does not slide in easily, ensure that it is correctly oriented before continuing.

5. Holding the fan assembly level, guide it into the carrier rails on each side and gently push it all the way into the slot, ensuring that it firmly engages with the connector.
6. When you are sure the fan assembly has properly engaged the connector, tighten the captive screw to secure the fan assembly in the slot.

**Note**

The fans are controlled automatically by the device.

When a fan assembly is installed in a slot, the power LED on the fan assembly should turn on green to confirm that the fan assembly is correctly installed and running. Refer to “LED activity interpretation” on page 45.

**Caution**

If you do not install a module or a power supply in a slot, you must keep the slot filler panel in place. If you run the chassis with an uncovered slot, the system will overheat.



ExtremeRouting SLX 9640 Technical Specifications

System specifications

System component	Description
Enclosure	Chassis-mountable on a desktop, or in a standard 2 or 4-post rack kit
Power supplies	Dual redundant, hot-swappable power supplies supported with 650 W AC intake or exhaust airflow, or 650 W DC intake or exhaust airflow.
Fan assemblies	Six redundant, hot-swappable fan units with intake or exhaust airflow
Cooling	Forced-air cooling front-to-back or back-to-front
System architecture	Non-blocking shared-memory switch
System processors	Control path based on Intel Broadwell-DE. CPU 4-cores, 8-threads running at 2.2 GHz, 35W Data path based on Broadcom DUNE chipsets, Qumran MX (BCM8837x) - Broadcom packet processor and traffic manager

Data port specifications (Ethernet)

*	System component	Description	Maximum ports supported
	QSFP28 ports	100 GbE QSFP28 ports can support 40GE/4x10GE/100GE/4x25GE/2x50GE interfaces.	12
	SFP+ ports	The SFP+ ports can support 10GbE/1GbE interfaces. There are 24 x SFP+ ports.	24
	Ethernet management port	RJ-45 port with 10/100/1000 Mbps auto-negotiating capability	1

LEDs

System component	Description
Interface Port LEDs	<ul style="list-style-type: none"> • Solid Off: No Link • Solid ON: Link, no traffic • LED Flickering: Link, traffic activities
Power supply LEDs	<ul style="list-style-type: none"> • Off: No Power (no lights). • Green: Steady: Power GOOD - Main output and standby output enabled with no power supply warning or fault detected. • Amber Blinking: Warning - Power supply warning detected. • Amber Steady: FAULT - Power supply fault detected.
Fan module LEDs	<ul style="list-style-type: none"> • Power (Fan) LED: No light (LED is off) - Fan assembly does not have power. Green Steady - Fan Normal. • Status (Fan) LED: No light (LED is off) - Fan assembly is either healthy or does not have power. Amber Steady - Fan assembly is being initialized or has a failure (full or partial).

Other

System component	Description
Serial Cable	RJ-45 console cable
RJ-45 to DB9 adapter	1 (RJ-45 port to female DB9 connector)
AC power cord, power clip	For both units

Weight and physical dimensions

The SLX 9640 Switch Router is 1 RU and 16" in depth.

Model	Dimensions (with Fan FRU)	Weight (with 6 x Fan FRUs and 2 x PSUs without optics)
SLX 9640 Router	445 x 43.7 x 451.5 mm	8.96 Kg (19.712 lbs)
Fan tray	42.0 x 41.2 x 94.6 mm	0.18 Kg (.396 lb.)
Power Supply Unit	54.4 x 40.0 x 236.6 mm	0.76 Kg (1.672 lbs)

Environmental requirements

Condition	Operational	Non-operational
Ambient temperature	0°C to 40°C (32°F to 104°F) (F2B) -5°C to 50°C (23°F to 122°F) (F2B) with 6 fan assemblies	-40°C to 70°C (-40°F to 158°F)
Relative humidity (non-condensing)	5% to 95% at 50°C (122°F)	5% to 95% at 70°C (158°F)

Condition	Operational	Non-operational
Altitude (above sea level)	0 to 3,000 m (9,843 ft) safety -60 to 4,000 m (13,123 ft) operational	0 to 12,000 m (39,370 ft)
Shock	20 G, 11 ms, half-sine wave	33 G, 11 ms, half-sine wave
Vibration	1 G sine, 0.4 grms random, 5-500 Hz	2.4 G sine, 1.1 grms random, 5-500 Hz
Airflow	134 cfm (estimated with 2 power supplies, 6 fan assemblies)	N/A
Heat dissipation (worst case)	DC power supply 563 W AC power supply 581 W	N/A
Operating noise	52.6 dBA (6 fan assemblies, 25°C, typical loading)	N/A
MTBF (25°C, 60% CL, Telec)	306,419 hours with DC power supply 327,539 hours with AC power supply	N/A

Worst case operational temperature is measured at sea level with at least 4 fan assemblies, with maximum power consumption optics modules (5W QSFP28) fully loaded.

Power supply specifications (per PSU)

Power supply model	Maximum output power rating (DC)	Input voltage	Input line frequency	Maximum input current	Input line protection	Maximum inrush current
XBR-ACPWR-650-F	650 W	100-240V~	50-60Hz	12 A	Fuses	35A
XBR-ACPWR-650-R	650 W	100-240V~	50-60Hz	12 A	Fuses	35A
XBR-DCPWR-650-F	650 W	-48 - 60V	-	13.3 A	Fuses	40A
XBR-DCPWR-650-R	650 W	-48 - 60V	-	13.3 A	Fuses	40A

Power consumption (typical configuration)

All 100-GbE ports are linked up, loading with 10 percent traffic rate. Six fan assemblies. Fans at nominal speed.

@100 VAC Input (Input power ±5%)	@200 VAC Input (Input power ±5%)	@-48VDC	Minimum number of power supplies	Notes
169 W 577 BTU/hr	166 W 566 BTU/hr	168 W 573 BTU/hr	1 x 650 W AC 1 x 650 W DC	1 power supply
178 W 607 BTU/hr	176 W 601 BTU/hr	179 W 611 BTU/hr	1 x 650 W AC 1 x 650 W DC	2 power supplies

Power consumption (maximum configuration)

All 100-GbE ports are linked up, loading with 100 percent traffic rate. Two power supplies and six fan assemblies. Fans at high speed.

@100 VAC Input (Input power $\pm 5\%$)	@200 VAC Input (Input power $\pm 5\%$)	@-48VDC	Minimum number of power supplies	Notes
570 W 1,945 BTU/hr	544.1 W 1,857 BTU/hr	552 W 1,884 BTU/hr	1 x 650 W AC 1 x 650 W DC	1 power supply
581.2 W 1,983 BTU/hr	562.4 W 1,919 BTU/hr	563 W 1,921 BTU/hr	1 x 650 W AC 1 x 650 W DC	2 power supplies

Data port specifications (Ethernet)

System component	Description	Maximum ports supported
QSFP28 ports	100 GbE QSFP28 ports can support 40GE/4x10GE/100GE/4x25GE/2x50GE interfaces.	12
SFP+ ports	The SFP+ ports can support 10GbE/1GbE interfaces. There are 24 x SFP+ ports.	24
Ethernet management port	RJ-45 port with 10/100/1000 Mbps auto-negotiating capability	1

Serial port specifications (pinout RJ-45)

Pin	Signal	Description
1	Not supported	N/A
2	Not supported	N/A
3	RXD	Receive data
4	GND	Logic ground
5	Not supported	N/A
6	TXD	Transmit data
7	Not supported	N/A
8	Not supported	N/A

Serial port specifications (pinout - mini-USB)

Pin	Signal	Description
1	Reserved	Not used
2	UART0_RX	Debug port (data received by SLX)
3	UART0_TX	Console port (data transmitted by SLX)

Pin	Signal	Description
4	Reserved	Not used
5	GND	Ground

Serial port specifications (protocol)

Parameter	Value
Baud	9600
Data bits	8
Parity	None
Stop bits	1
Flow control	None

Memory specifications

Parameter	Type	Size
Main memory	DDR4	32 GB
Boot flash	NOR Flash	32 MB
SSD	M.2 SATA III (2 slots)	64 GB per slot

Regulatory compliance (EMC)

- FCC Part 15, Subpart B
- EN 55024
- EM 55032 (CE Mark) (Class A)
- ICES-003
- VCCI
- EN 300 386
- CNS 13438
- KN 32
- KN 35
- TCVN 7189
- EN 61000-3-2
- EN 61000-3-3
- GB 9254
- CISPR 32
- 2014/30/EU
- AS/NZS CISPR32 (Australia) (Class A)

Regulatory compliance (safety)

- EN/UL 60825
- EN/UL/CSA/IEC 60950-1
- GB 4943.1
- CNS 14336-1
- 2014/35/EU

Regulatory compliance (environmental)

- 2011/65/EU - Restriction of the use of certain hazardous substance in electrical and electronic equipment (EU RoHS).
- 2012/19/EU - Waste electrical and electronic equipment (EU WEEE).
- 94/62/EC - packaging and packaging waste (EU).
- 2006/66/EC - batteries and accumulators and waste batteries and accumulators (EU battery directive).
- 1907/2006 of the European Parliament and of the Council of 18 December 2006 concerning the Registration, Evaluation, Authorisation and Restriction of Chemicals (EU REACH).
- Section 1502 of the Dodd-Frank Wall Street Reform and Consumer Protection Act of 2010 - U.S. Conflict Minerals.
- 30/2011/TT-BCT - Vietnam circular.
- SJ/T 11363-2006 Requirements for Concentration Limits for Certain Hazardous Substances in EIPs (China).
- SJ/T 11364-2006 Marking for the Control of Pollution Caused by EIPs (China).



Regulatory Statements

- [CE statement on page 98](#)
- [China ROHS on page 98](#)
- [BSMI statement \(Taiwan\) on page 99](#)
- [Canadian requirements on page 99](#)
- [China CCC statement on page 100](#)
- [Europe and Australia \(CISPR 32 Class A Warning\) on page 100](#)
- [FCC warning \(US only\) on page 100](#)
- [Germany statement on page 101](#)
- [KCC statement \(Republic of Korea\) on page 101](#)
- [VCCI statement on page 101](#)
- [Japan power cord on page 102](#)

CE statement



Important

This is a Class A product. In a domestic environment, this product might cause radio interference, and the user might be required to take corrective measures.

The standards compliance label on this device contains the CE mark which indicates that this system conforms to the provisions of the following European Council directives, laws, and standards:

- Electromagnetic Compatibility (EMC) Directive 2014/30/EU
- Low Voltage Directive (LVD) 2014/35/EU
- EN 55032/EN 55024 (European Immunity Requirements)
 - EN61000-3-2/IEC61000-3-2 (European and Japanese Harmonics Spec)
 - EN61000-3-3

China ROHS

Refer to the latest revision of the China ROHS document (P/N 53-1000428-xx) which ships with the product.

BSMI statement (Taiwan)

警告使用者：
此為甲類資訊技術設備，於居住環境中使用時
擾動，在此種情況下，使用者會被要求採取

Warning:

This is Class A product. In a domestic environment this product may cause radio interference in which case the user may be required to take adequate measures.

Canadian requirements

This Class A digital apparatus meets all requirements of the Canadian Interference-Causing Equipment Regulations, ICES-003 Class A.

Cet appareil numérique de la classe A est conforme à la norme NMB-003 du Canada.

Operation of this equipment in a residential area is likely to cause harmful interference, in which case the user will be required to correct the interference at the user's own expense.

Germany statement

Machine noise information regulation - 3. GPSGV, the highest sound pressure level value is 70.0 dB(A) in accordance with EN ISO 7779.

Maschinenlärminformations-Verordnung - 3. GPSGV, der höchste Schalldruckpegel beträgt 70.0 dB(A) gemäss EN ISO 7779.

KCC statement (Republic of Korea)

이 기기는 업무용 환경에서 사용할 목적으로 적합성평가를 받은 기기로서 가정용 환경에서 사용하는 경우 전파간섭의 우려가 있습니다.

Class A device (Broadcasting Communication Device for Office Use): This device obtained EMC registration for office use (Class A), and may be used in places other than home. Sellers and/or users need to take note of this.

VCCI statement

この装置は、クラスA情報技術装置です。この装置を家庭環境で使用すると電波妨害を引き起こすことがあります。この場合には使用者が適切な対策を講ずるよう要求されることがあります。 VCCI-A

This is a Class A product based on the standard of the Voluntary Control Council for Interference by Information Technology Equipment (VCCI). If this equipment is used in a domestic environment, radio disturbance might arise. When such trouble occurs, the user might be required to take corrective actions.

Japan power cord



注意 - 添付の電源コードを他の装置や用途に
使用しない

添付の電源コードは本装置に接続し、使用する
ことを目的として設計され、その安全性が確認
されているものです。決して他の装置や用途に
使用しないでください。火災や感電の原因とな
る恐れがあります。

English translation of above statement

ATTENTION: Never use the power cord packed with your equipment for other products.



Cautions and Danger Notices

[Cautions](#) on page 103

[Danger Notices](#) on page 109

Cautions

A Caution statement alerts you to situations that can be potentially hazardous to you or cause damage to hardware, firmware, software, or data.

Ein Vorsichtshinweis warnt Sie vor potenziellen Personengefahren oder Beschädigung der Hardware, Firmware, Software oder auch vor einem möglichen Datenverlust

Un message de mise en garde vous alerte sur des situations pouvant présenter un risque potentiel de dommages corporels ou de dommages matériels, logiciels ou de perte de données.

Un mensaje de precaución le alerta de situaciones que pueden resultar peligrosas para usted o causar daños en el hardware, el firmware, el software o los datos.

General cautions



Caution

Changes or modifications made to this device that are not expressly approved by the party responsible for compliance could void the user's authority to operate the equipment.

VORSICHT	Falls dieses Gerät verändert oder modifiziert wird, ohne die ausdrückliche Genehmigung der für die Einhaltung der Anforderungen verantwortlichen Partei einzuholen, kann dem Benutzer der weitere Betrieb des Gerätes untersagt werden.
MISE EN GARDE	Les éventuelles modifications apportées à cet équipement sans avoir été expressément approuvées par la partie responsable d'en évaluer la conformité sont susceptibles d'annuler le droit de l'utilisateur à utiliser cet équipement.
PRECAUCIÓN	Si se realizan cambios o modificaciones en este dispositivo sin la autorización expresa de la parte responsable del cumplimiento de las normas, la licencia del usuario para operar este equipo puede quedar anulada.



Caution

Disassembling any part of the power supply and fan assembly voids the warranty and regulatory certifications. There are no user-serviceable parts inside the power supply and fan assembly.

VORSICHT	Das Zerlegen von Netzteilen oder Lüftereinheiten macht die Garantie und die gesetzlichen Zertifizierungen ungültig. Die Netzteile und Lüftereinheiten enthalten keine Teile, die vom Benutzer gewartet werden können.
MISE EN GARDE	Le démontage d'une pièce du bloc d'alimentation ou du ventilateur annule la garantie et les certificats de conformité. Aucune pièce du bloc de l'alimentation ou du ventilateur ne peut être réparée par l'utilisateur.
PRECAUCIÓN	Si se desmonta cualquier pieza del módulo de fuente de alimentación y ventiladores, la garantía y las certificaciones normativas quedan anuladas. En el interior del

	módulo de fuente de alimentación y ventiladores no hay piezas que pueda reparar el usuario.
--	---

**Caution**

Make sure the airflow around the front, and back of the device is not restricted.

VORSICHT	Stellen Sie sicher, dass an der Vorderseite, den Seiten und an der Rückseite der Luftstrom nicht behindert wird.
MISE EN GARDE	Vérifiez que rien ne restreint la circulation d'air devant, derrière et sur les côtés du dispositif et qu'elle peut se faire librement.
PRECAUCIÓN	Asegúrese de que el flujo de aire en las inmediaciones de las partes anterior, laterales y posterior del instrumento no esté restringido.

**Caution**

Ensure that the airflow direction of the power supply unit matches that of the installed fan tray. The power supplies and fan trays are clearly labeled with either a green arrow with an "E", or an orange arrow with an "I."

VORSICHT	Vergewissern Sie sich, dass die Luftstromrichtung des Netzteils der eingebauten Lüftereinheit entspricht. Die Netzteile und Lüftereinheiten sind eindeutig mit einem grünen Pfeil und dem Buchstaben "E" oder einem orangefarbenen Pfeil mit dem Buchstaben "I" gekennzeichnet.
MISE EN GARDE	Veillez à ce que le sens de circulation de l'air du bloc d'alimentation corresponde à celui du tiroir de ventilation installé. Les blocs d'alimentation et les tiroirs de ventilation sont étiquetés d'une flèche verte avec un "E" ou d'une flèche orange avec un "I".
PRECAUCIÓN	Asegúrese de que la dirección del flujo de aire de la unidad de alimentación se corresponda con la de la bandeja del ventilador instalada. Los dispositivos de alimentación y las bandejas del ventilador están etiquetadas claramente con una flecha verde y una "E" o con una flecha naranja y una "I".

**Caution**

To protect the serial port from damage, keep the cover on the port when not in use.

VORSICHT	Um den seriellen Anschluss vor Beschädigungen zu schützen, sollten Sie die Abdeckung am Anschluss belassen, wenn er nicht verwendet wird.
MISE EN GARDE	Mette le bouchon de protection sur le port série lorsqu'il ne sert pas pour éviter de l'endommager.
PRECAUCIÓN	Para evitar que se dañe el puerto serie, mantenga la cubierta colocada sobre el puerto cuando no lo utilice.

**Caution**

Never leave tools inside the chassis.

	Lassen Sie keine Werkzeuge im Chassis zurück.
--	---

VORSICHT	
MISE EN GARDE	Ne laissez jamais d'outils à l'intérieur du châssis
PRECAUCIÓN	No deje nunca herramientas en el interior del chasis.

**Caution**

If you do not install a module or a power supply in a slot, you must keep the slot filler panel in place. If you run the chassis with an uncovered slot, the system will overheat.

VORSICHT	Falls kein Modul oder Netzteil im Steckplatz installiert wird, muss die Steckplatztafel angebracht werden. Wenn ein Steckplatz nicht abgedeckt wird, läuft das System heiß.
MISE EN GARDE	Si vous n'installez pas de module ou de bloc d'alimentation dans un slot, vous devez laisser le panneau du slot en place. Si vous faites fonctionner le châssis avec un slot découvert, le système surchauffera.
PRECAUCIÓN	Si no instala un módulo o un fuente de alimentación en la ranura, deberá mantener el panel de ranuras en su lugar. Si pone en funcionamiento el chasis con una ranura descubierta, el sistema sufrirá sobrecalentamiento.

**Caution**

Use the screws specified in the procedure. Using longer screws can damage the device.

VORSICHT	Verwenden Sie die in der Anleitung aufgeführten Schrauben. Mit längeren Schrauben wird das Gerät möglicherweise beschädigt.
MISE EN GARDE	Utilisez les vis mentionnées dans les instructions. L'utilisation de vis plus longues peut endommager l'appareil.
PRECAUCIÓN	Utilice los tornillos especificados en el procedimiento. Si utiliza tornillos de mayor longitud, podría dañar el dispositivo.

**Caution**

Do not install the device in an environment where the operating ambient temperature might exceed 50°C (122°F).

VORSICHT	Das Gerät darf nicht in einer Umgebung mit einer Umgebungsbetriebstemperatur von über 50°C (122°F) installiert werden.
MISE EN GARDE	N'installez pas le dispositif dans un environnement où la température d'exploitation ambiante risque de dépasser 50°C (122°F).
PRECAUCIÓN	No instale el instrumento en un entorno en el que la temperatura ambiente de operación pueda exceder los 50°C (122°F).

**Caution**

The device must be turned off and disconnected from the fabric during this procedure.

VORSICHT	Bei diesem Verfahren muss das Gerät ausgeschaltet und von der Fabric getrennt sein.
MISE EN GARDE	Au cours de cette procédure, l'appareil doit être éteint et déconnecté du réseau.
PRECAUCIÓN	El dispositivo debe estar apagado y desconectado del fabric durante este

**Caution**

All devices with DC power supplies are intended for installation in restricted access areas only.

GARDE	installés uniquement dans des zones à accès réglementé. Une zone à accès réglementé est une zone dont l'accès n'est possible qu'au personnel de service qualifié utilisant un verrou, une clé ou un outil spécial, ou d'autres moyens de sécurité, et qui est contrôlée par les autorités responsables du site.
PRECAUCIÓN	Todos los dispositivos con fuentes de alimentación de corriente continua (CC) han sido diseñados únicamente para su instalación en áreas restringidas/ zonas de acceso restringido. Se entiende como área de acceso restringido un lugar al que solo puede acceder personal de servicio mediante el uso de una herramienta especial, llave y cerrojo u otro medio de seguridad similar, y que esté controlado por la autoridad responsable de esa ubicación.

**Caution**

Static electricity can damage the chassis and other electronic devices. To avoid damage, keep static-sensitive devices in their static-protective packages until you are ready to install them.

VORSICHT	Statische Elektrizität kann das System und andere elektronische Geräte beschädigen. Um Schäden zu vermeiden, entnehmen Sie elektrostatisch empfindliche Geräte erst aus deren antistatischer Schutzhülle, wenn Sie bereit für den Einbau sind.
MISE EN GARDE	L'électricité statique peut endommager le châssis et les autres appareils électroniques. Pour éviter tout dommage, conservez les appareils sensibles à l'électricité statique dans leur emballage protecteur tant qu'ils n'ont pas été installés.
PRECAUCIÓN	La electricidad estática puede dañar el chasis y otros dispositivos electrónicos. A fin de impedir que se produzcan daños, conserve los dispositivos susceptibles de dañarse con la electricidad estática dentro de los paquetes protectores hasta que esté listo para instalarlos.

**Caution**

Use a separate branch circuit for each power cord, which provides redundancy in case one of the circuits fails.

VORSICHT	Es empfiehlt sich die Installation eines separaten Stromkreisweiges für jede Elektroschnur als Redundanz im Fall des Ausfalls eines Stromkreises.
MISE EN GARDE	Utilisez un circuit de dérivation différent pour chaque cordon d'alimentation ainsi, il y aura un circuit redondant en cas de panne d'un des circuits.
PRECAUCIÓN	Use un circuito derivado separado para cada cordón de alimentación, con lo que se proporcionará redundancia en caso de que uno de los circuitos falle.

**Caution**

Ensure that the device does not overload the power circuits, wiring, and over-current protection. To determine the possibility of overloading the supply circuits, add the ampere (amp) ratings of all devices installed on the same circuit as the device. Compare this total with the rating limit for the circuit. The maximum ampere ratings are usually printed on the devices near the input power connectors.

VORSICHT	Stromkreise, Verdrahtung und Überlastschutz dürfen nicht durch das Gerät überbelastet werden. Addieren Sie die Nennstromleistung (in Ampere) aller Geräte, die am selben Stromkreis wie das Gerät installiert sind. Somit können Sie feststellen, ob die Gefahr einer Überbelastung der Versorgungsstromkreise vorliegt. Vergleichen Sie diese Summe mit der Nennstromgrenze des Stromkreises. Die Höchstnennströme
----------	---

	(in Ampere) stehen normalerweise auf der Geräterückseite neben den Eingangsstromanschlüssen.
MISE EN GARDE	Assurez-vous que le dispositif ne risque pas de surcharger les circuits d'alimentation, le câblage et la protection de surintensité. Pour déterminer le risque de surcharge des circuits d'alimentation, additionnez l'intensité nominale (ampères) de tous les dispositifs installés sur le même circuit que le dispositif en question. Comparez alors ce total avec la limite de charge du circuit. L'intensité nominale maximum en ampères est généralement imprimée sur chaque dispositif près des connecteurs d'entrée d'alimentation.
PRECAUCIÓN	Verifique que el instrumento no sobrecargue los circuitos de corriente, el cableado y la protección para sobrecargas. Para determinar la posibilidad de sobrecarga en los circuitos de suministros, añada las capacidades nominales de corriente (amp) de todos los instrumentos instalados en el mismo circuito que el instrumento. Compare esta suma con el límite nominal para el circuito. Las capacidades nominales de corriente máximas están generalmente impresas en los instrumentos, cerca de los conectores de corriente de entrada.

**Caution**

Before plugging a cable into any port, be sure to discharge the voltage stored on the cable by touching the electrical contacts to ground surface.

VORSICHT	Bevor Sie ein Kabel in einen Anschluss einstecken, entladen Sie jegliche im Kabel vorhandene elektrische Spannung, indem Sie mit den elektrischen Kontakten eine geerdete Oberfläche berühren.
MISE EN GARDE	Avant de brancher un câble à un port, assurez-vous de décharger la tension du câble en reliant les contacts électriques à la terre.
PRECAUCIÓN	Antes de conectar un cable en cualquier puerto, asegúrese de descargar la tensión acumulada en el cable tocando la superficie de conexión a tierra con los contactos eléctricos.

**Caution**

To prevent damage to the chassis and components, never attempt to lift the chassis using the fan or power supply handles. These handles were not designed to support the weight of the chassis.

VORSICHT	Alle Geräte mit Wechselstromquellen sind nur zur Installation in Sperrbereichen bestimmt. Ein Sperrbereich ist ein Ort, zu dem nur Wartungspersonal mit einem Spezialwerkzeug, Schloss und Schlüssel oder einer anderen Schutzvorrichtung Zugang hat.
MISE EN GARDE	Pour éviter d'endommager le châssis et les composants, ne jamais tenter de soulever le châssis par les poignées du ventilateur ou de l'alimentation. Ces poignées n'ont pas été conçues pour supporter le poids du châssis.
PRECAUCIÓN	Para prevenir daños al chasis y a los componentes, nunca intente levantar el chasis usando las asas de la fuente de alimentación o del ventilador. Tales asas no han sido diseñadas para soportar el peso del chasis.

Danger Notices

A Danger statement indicates conditions or situations that can be potentially lethal or extremely hazardous to you. Safety labels are also attached directly to products to warn of these conditions or situations.

Ein Gefahrenhinweis warnt vor Bedingungen oder Situationen die tödlich sein können oder Sie extrem gefährden können. Sicherheitsetiketten sind direkt auf den jeweiligen Produkten angebracht um vor diesen Bedingungen und Situationen zu warnen.

Un énoncé de danger indique des conditions ou des situations potentiellement mortelles ou extrêmement dangereuses. Des étiquettes de sécurité sont posées directement sur le produit et vous avertissent de ces conditions ou situations.

Una advertencia de peligro indica condiciones o situaciones que pueden resultar potencialmente letales o extremadamente peligrosas. También habrá etiquetas de seguridad pegadas directamente sobre los productos para advertir de estas condiciones o situaciones.

General dangers



Warning

The procedures in this manual are for qualified service personnel.

GEFAHR	Die Vorgehensweisen in diesem Handbuch sind für qualifiziertes Servicepersonal bestimmt.
DANGER	Les procédures décrites dans ce manuel doivent être effectuées par un personnel de maintenance qualifié.
PELIGRO	Los procedimientos de este manual deben llevarlos a cabo técnicos cualificados.



Warning

Batteries used for RTC/NVRAM backup are not located in operator-access areas. There is a risk of explosion if a battery is replaced by an incorrect type. Dispose of used components with batteries according to local ordinance and regulations.

GEFAHR	Die für die RTC/NVRAM-Sicherung verwendeten Batterien, befinden sich nicht in für den Bediener zugänglichen Bereichen. Bei Ersetzen der Batterie durch einen falschen Typ besteht Explosionsgefahr. Entsorgen Sie gebrauchte Komponenten mit Batterien gemäß den lokalen Auflagen und Vorschriften.
DANGER	Les batteries utilisées pour la sauvegarde de l'horloge et de la mémoire ne sont pas remplaçables par l'opérateur. Il y a risque d'explosion si la batterie est remplacée par une d'un type incompatible. Jetez/recyclez les batteries conformément aux normes locales.
PELIGRO	Las baterías usadas para respaldo de RTC/NVRAM no se encuentran en áreas de acceso del operador. Existe riesgo de explosión si una batería es remplazada por un

	tipo incorrecto. Deshágase de los componentes usados con las baterías según las políticas y regulaciones locales.
--	---

**Warning**

To avoid high voltage shock, do not open the device while the power is on.

GEFAHR	Das eingeschaltete Gerät darf nicht geöffnet werden, da andernfalls das Risiko eines Stromschlags mit Hochspannung besteht.
DANGER	Afin d'éviter tout choc électrique, n'ouvrez pas l'appareil lorsqu'il est sous tension.
PELIGRO	Para evitar una descarga de alto voltaje, no abra el dispositivo mientras esté encendido.

**Warning**

Make sure the rack housing the device is adequately secured to prevent it from becoming unstable or falling over.

GEFAHR	Stellen Sie sicher, dass das Gestell für die Unterbringung des Geräts auf angemessene Weise gesichert ist, so dass das Gestell oder der Schrank nicht wackeln oder umfallen kann.
DANGER	Vérifiez que le bâti abritant le dispositif est bien fixé afin qu'il ne devienne pas instable ou qu'il ne risque pas de tomber.
PELIGRO	Verifique que el bastidor que alberga el instrumento está asegurado correctamente para evitar que pueda hacerse inestable o que caiga.

**Warning**

Make sure that the power source circuits are properly grounded, then use the power cord supplied with the device to connect it to the power source.

GEFAHR	Stellen Sie sicher, dass die Stromkreise ordnungsgemäß geerdet sind. Benutzen Sie dann das mit dem Gerät gelieferte Stromkabel, um es an die Stromquelle anzuschließen.
DANGER	Vérifiez que les circuits de sources d'alimentation sont bien mis à la terre, puis utilisez le cordon d'alimentation fourni avec le dispositif pour le connecter à la source d'alimentation.
PELIGRO	Verifique que circuitos de la fuente de corriente están conectados a tierra correctamente; luego use el cordón de potencia suministrado con el instrumento para conectarlo a la fuente de corriente

**Warning**

Before beginning the installation, see the precautions in "Power precautions."

GEFAHR	Vor der Installation siehe Vorsichtsmaßnahmen unter "Power Precautions" (Vorsichtsmaßnahmen in Bezug auf elektrische Ablagen).
DANGER	Avant de commencer l'installation, consultez les précautions décrites dans "Power Precautions" (Précautions quant à l'alimentation).
PELIGRO	Antes de comenzar la instalación, consulte las precauciones en la sección "Power Precautions" (Precauciones sobre corriente).

**Warning**

Be careful not to accidentally insert your fingers into the fan tray while removing it from the chassis. The fan may still be spinning at a high speed.

PELIGRO	Radiacion de Laser. No vea directamente con Instrumentos Opticos. Clase 1M de Productos de Laser.
警告	レーザー放射 光学器具で直接ビームを見ないこと クラス 1 M レーザ製品

**Warning**

Use only optical transceivers that are qualified by Extreme Networks, Inc. and comply with the FDA Class 1 radiation performance requirements defined in 21 CFR Subchapter I, and with IEC 60825 and EN60825. Optical products that do not comply with these standards might emit light that is hazardous to the eyes.

GEFAHR	Verwenden Sie nur optische Transceiver, die von Extreme Networks, Inc. zugelassen sind und die die Anforderungen gemäß FDA Class 1 Radiation Performance Standards in 21 CFR, Unterkapitel I, sowie IEC 60825 und EN60825 erfüllen. Optische Produkte, die diese Normen nicht erfüllen, können Strahlen aussenden, die für das menschliche Auge gefährlich sind.
DANGER	Utilisez uniquement des émetteurs-récepteurs optiques certifiés par Extreme Networks, Inc. et conformes aux exigences sur la puissance de rayonnement de catégorie 1 de la FDA définies au sous-chapitre 21 CFR I et à les normes IEC 60825 et EN60825. Les produits optiques non-conformes à ces normes sont susceptibles d'émettre une lumière dangereuse pour les yeux.
PELIGRO	Utilice sólo transceptores ópticos aprobados por Extreme Networks, Inc. y que cumplan con las normas IEC 60825 y EN60825, y con los estándares de rendimiento Clase 1 de FDA definidos en el subcapítulo I de 21 CFR. Los productos ópticos que no cumplan con estos estándares pueden emitir luz dañina para los ojos.