

Overview of the AP3935

The AP3935 is designed to extend your Wireless LAN around indoor locations. The AP3935 supports the 802.11ac and 802.11n wireless standards, with full backward compatibility with legacy 802.11a, and 802.11b/g devices. The AP3935 interoperates fully with Wireless LANs, including support for VoWLAN, branch office mode, guest services, RTLS, availability, and mobility features.

Operating Temperature: 0 - 50C.

Caution: The AP3935i-IL requires a minimum base firmware of 10.11.02.

Note: The AP3935 is available in both an “i” model (with internal antennas) and an “e” model (with external antennas). In this Quick Reference, any reference to AP3935 applies to all models.

AP3935 models have the following features:

- Radios: 2 radios (2.4 GHz and 5 GHz)
- LEDs: 5 (see Figure 3)
- Power: PoE 802.3at for full performance; (802.3af for low performance mode) DC power supply (see Table 1).
- Antennas:
 - WS-AP3935i: 8 **internal** single band antenna assemblies
 - WS-AP3935e: 8 **external** RPSMA antenna connectors (external antennas must be ordered separately)
- Adjustable mounting brackets for drop ceiling T-bar rail.

Figure 1 3935i Access Point



Figure 2 3935e Access Point



For detailed installation information about the AP3935, see the *ExtremeWireless AP3935 Installation Guide*. Table 1 shows ways to power the AP3935.

Table 1 Powering the AP3935

Power Source	Description
Power over Ethernet (PoE)	Power is provided through two Ethernet ports (LAN port). This is the preferred method of powering the AP on ceiling and wall installations.
External 12V DC power (optional)	The AP3935 can also be powered by an external DC power supply plugged into an AC source. Plug the supply's input jack into the DC-In port (Callout 4 in Figure 4).

Figure 3 shows the LEDs on the front of the AP3935e.

Figure 3 LEDs on AP Front Face

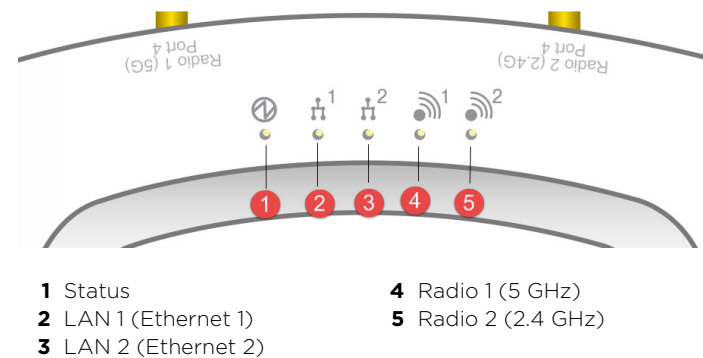

- | | |
|----------------------|---------------------|
| 1 Status | 4 Radio 1 (5 GHz) |
| 2 LAN 1 (Ethernet 1) | 5 Radio 2 (2.4 GHz) |
| 3 LAN 2 (Ethernet 2) | |

Figure 4 3935e Access Point bottom view



Mounting and Connecting the AP

Electrical Hazard: Only qualified personnel should perform installation procedures.

Mounting brackets are included for quick and easy mounting of the AP3935 drop ceilings. The wall bracket as shown in Figure 7 is optional.

Use these instructions as guidelines for mounting and connecting the AP3935 easily and safely.

Mount the AP no more than 2 ft. from a T-bar support.

Mounting on a Drop Ceiling

- 1 Slide the ceiling mount bracket base into the metal base. The locking tab fits into the groove in the fins. See Figure 5.

Figure 5 Attaching Mount Bracket to the Access Point

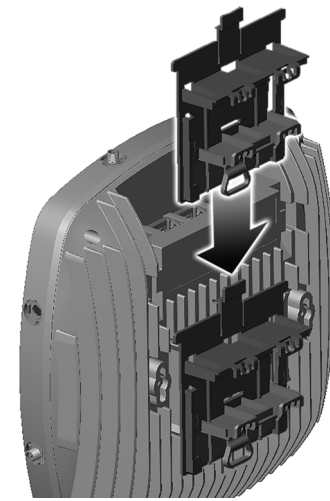

- 2 Remove the ceiling panels around the drop ceiling T-bar rails and verify that the Ethernet cable can reach the AP at the mounting point.
- 3 Slightly lift the movable T-bar locking tab to increase the space between the stationary and the slider T-bar sides of the bracket. Then hook the stationary end of the T-bar bracket onto the T-bar, as shown in Figure 6.
- 4 While holding the AP with one hand, reach the other hand over the T-bar and grasp both the stationary and movable sides of the bracket. Push the bracket parts together so they both grasp the T-bar and the locking tab clicks into place.
- 5 While still holding the AP, rock it back and forth to ensure that it is securely mounted.

Figure 6 Attaching the AP3935 on a drop ceiling T-bar rail

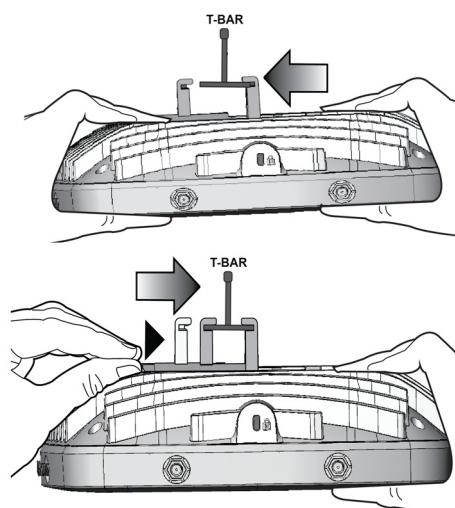

- 6 Make a hole through the ceiling panel closest to the power slot on the AP. Run the Ethernet cable through the hole and into an RJ45 LAN port in the recessed connector bay.
- 7 If necessary, cut the tiles for the cables, attach the cables to the AP, and replace the tiles. Then replace the displaced ceiling panels.

Mounting on a Wall/Solid Flat Ceiling

- 1 Determine the spot on the wall to mount the AP (near the ceiling, but in reach of the Ethernet cable and a wall power outlet if you are using external power).
- 2 To mount the AP directly on the wall with two screws, use the provided template and mark the two drill holes on the wall. In drywall, the drill holes should be 6MM to 0.250" in diameter.
- 3 Drill two holes in the wall to match the center of the two keyhole slots in the back of the AP bracket.
- 4 Screw the anchors into the holes until they are flush with the wall. Screw the provided mounting screws into the anchors with the head protruding 1/16" from the anchor.
- 5 Place the back of the AP against the wall with the protruding mounting screw heads fitting through the keyhole slots on the back of the AP. Slide the AP down until the AP rests on the mounting screw heads.
- 6 For added stability and security, use a Kensington lock. When mounting on the ceiling, a Kensington lock and bracket are required.

Figure 7 Mounting the AP3935 to a Flat Wall.

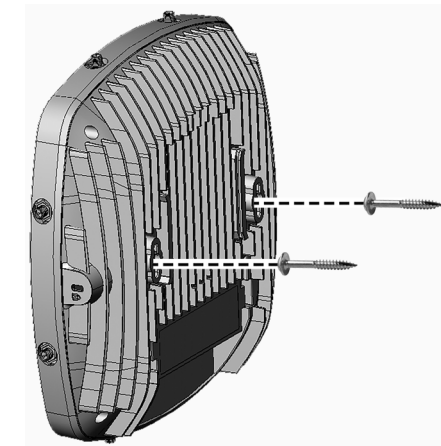

Note: You can mount the AP using an optional mounting bracket (30513, WS-MBI-WALL03) to a flat ceiling.

Connecting a Power Supply to the AP3935

To power the AP3935 with optional (30512, WS-PSI12V-MR2) external 12V DC power supply, plug the power cord into the power connector (Figure 4) on the back of the AP. There is no wall mount for the 12V DC power supply. When the device is powered on, the power LED on the front face of the AP is lit.

LAN/Console Connections

The AP3935 has two LAN (Ethernet) ports and a Console port. Refer to Figure 4 for the location of these ports. During administration and maintenance, the AP must have a power connection through either an Ethernet PoE cable or a DC power supply.

Note: LAN/Console connectors with shrouds will not fit into the ports. Remove the shroud or use an optional jumper cable.

External Antennas (WS-AP3935e Only)

Install the external antennas intended for area coverage.

For more information about the optional installation bracket, the optional power supply, and antenna selection and installation, refer to the *ExtremeWireless AP3935 Installation Guide*.

Notice

Copyright © 2016 Extreme Networks, Inc. All Rights Reserved.

Legal Notices

Extreme Networks, Inc. reserves the right to make changes in specifications and other information contained in this document and its website without prior notice. The reader should in all cases consult representatives of Extreme Networks to determine whether any such changes have been made.

The hardware, firmware, software or any specifications described or referred to in this document are subject to change without notice.

Trademarks

Extreme Networks and the Extreme Networks logo are trademarks or registered trademarks of Extreme Networks, Inc. in the United States and/or other countries.

All other names (including any product names) mentioned in this document are the property of their respective owners and may be trademarks or registered trademarks of their respective companies/owners.

For additional information on Extreme Networks trademarks, please see: www.extremenetworks.com/company/legal/trademarks/

Documentation & Support

For product support, including documentation, visit: www.extremenetworks.com/support/

Contact

Extreme Networks, Inc.
6480 Via Del Oro
San Jose, CA 95119
Tel: +1 408-579-2800
Toll-free: +1 888-257-3000

Regulatory and Compliance Information Safety Guidelines

This section contains notices that are intended to protect your personal safety and prevent damage to the equipment.

Suitable for use in environmental air space in accordance with Section 300.22.C of the National Electrical Code, and Sections 2-128, 12-010(3) and 12-100 of the Canadian Electrical Code, Part 1, C22.1.

Convient à l'espace de ventilation environnemental, conformément à la section 300.22.C du Code national de l'électricité et aux sections 2-128, 12-010(3) et 12-100 du Code canadien de l'électricité, partie 1, C22.1.

Qualified Personnel:

 **Electrical Hazard:** Only qualified personnel should perform installation procedures. Within the context of the safety notes in this documentation, qualified persons are defined as persons who are authorized to commission, ground and label devices, systems, and circuits in accordance with established safety practices and standards. A qualified person understands the requirements and risks involved with installing outdoor electrical equipment in accordance with national codes.

 **Caution:** Connect the equipment to Intra-Building networks only. Do not route cables outside.

 **Attention:** Connecter l'équipement à des réseaux intra-bâtiment seulement. Ne pas acheminer les câbles à l'extérieur.

Federal Communications Commission (FCC) Notice

This device complies with Part 15 of the FCC rules. Operation is subject to the following two conditions: (1) this device may not cause harmful interference, and (2) this device must accept any interference received, including interference that may cause undesired operation.

This equipment has been tested and found to comply with the limits for a Class A digital device, pursuant to Part 15 of the FCC Rules. These limits are designed to provide reasonable protection against harmful interference when the equipment is operated in a commercial environment. This equipment generates, uses, and can radiate radio frequency energy, and, if not installed and used in accordance with the instruction manual, may cause harmful interference to radio communications. Operation of this equipment in a residential area is likely to cause harmful interference in which case the user will be required to correct the interference at his own expense.

The antennas used for this transmitter must be installed to provide a separation distance of at least 25 cm from all persons and must not be co-located or operating in conjunction with another antenna or transmitter.

 **Note:** Changes or modifications made to this device which are not expressly approved by the party responsible for compliance could void the user's authority to operate the equipment.

Industry Canada Notice

This device complies with Industry Canada license-exempt RSS standard(s). Operation is subject to the following two conditions: (1) this device may not

cause interference, and (2) this device must accept any interference, including interference that may cause undesired operation of the device.

Le présent appareil est conforme aux CNR d'Industrie Canada applicables aux appareils radio exempts de licence. L'exploitation est autorisée aux deux conditions suivantes : (1) l'appareil ne doit pas produire de brouillage, et (2) l'utilisateur de l'appareil doit accepter tout brouillage radioélectrique subi, même si le brouillage est susceptible d'en compromettre le fonctionnement.

This radio transmitter (IC: 4141B-4411AC) has been approved by Industry Canada to operate with the antenna types listed below with the maximum permissible gain and required antenna impedance for each antenna type indicated. Antenna types not included in this list, having a gain greater than the maximum gain indicated for that type, are strictly prohibited for use with this device.

Le présent émetteur radio (IC: 4141B-4411AC) a été approuvé par Industrie Canada pour fonctionner avec les types d'antenne énumérés ci-dessous et ayant un gain admissible maximal et l'impédance requise pour chaque type d'antenne. Les types d'antenne non inclus dans cette liste, ou dont le gain est supérieur au gain maximal indiqué, sont strictement interdits pour l'exploitation de l'émetteur.

Antenna List:

Part No. (Short Description)	Frequency Band	Antenna Type	2.4G Gain	5G Gain
30702 (WS-AI-DQ05120)	2.4G/5G	Sector	5.5	5.5
30703 (WS-AI-5Q04060)	5G	Sector	N/A	4
30704 (WS-AI-2Q05060)	2.4G	Sector	5	N/A
30705 (WS-AI-DE07025)	2.4G/5G	Sector	7.5	6.5
30706 (WS-AI-5Q05025)	5G	Sector	N/A	4.5
30707 (WS-AI-DE10055)	2.4G/5G	Sector	10.5	7.5
30709 (WS-ANT-2DIP-4)	2.4G	DIPOLE	4.66	N/A
30710 (WS-ANT-5DIP-4)	5G	DIPOLE	N/A	4.67
WS-AI-DQ04360 (WS-AI-DQ04360)	2.4G/5G	Ceiling Mount Omni	4	7

Note: All antennas use an RP SMA Male connector.

The antennas used for this transmitter must be installed to provide a separation distance of at least 34 cm from all persons and must not be co-located or operating in conjunction with another antenna or transmitter.

Cet équipement est conforme aux limites d'exposition aux rayonnements IC établies pour un environnement non contrôlé. Cet équipement doit être installé et utilisé avec un minimum de 34 cm de distance entre la source de rayonnement et votre corps.

Dynamic Frequency Selection (DFS) for devices operating in the bands 5250- 5350 MHz,

5470-5600 MHz and 5650-5725 MHz

Sélection dynamique de fréquences (DFS) pour les dispositifs fonctionnant dans les bandes 5250-5350 MHz, 5470-5600 MHz et 5650-5725 MHz

The device for operation in the band 5150-5250 MHz is only for indoor use to reduce the potential for harmful interference to co-channel mobile satellite systems.

les dispositifs fonctionnant dans la bande 5150-5250 MHz sont réservés uniquement pour une utilisation à l'intérieur afin de réduire les risques de brouillage préjudiciable aux systèmes de satellites mobiles utilisant les mêmes canaux.

The maximum antenna gain permitted for devices in the bands 5250-5350 MHz and 5470-5725 MHz shall be such that the equipment still complies with the e.i.r.p. limit.

le gain maximal d'antenne permis pour les dispositifs utilisant les bandes 5250-5350 MHz et

5470-5725 MHz doit se conformer à la limite de p.i.r.e.

The maximum antenna gain permitted for devices in the band 5725-5850 MHz shall be such that the equipment still complies with the e.i.r.p. limits specified for point-to-point and non-point-to-point operation as appropriate.

le gain maximal d'antenne permis (pour les dispositifs utilisant la bande 5725-5850 MHz)

doit se conformer à la limite de p.i.r.e. spécifiée pour l'exploitation point à point et non point à point, selon le cas.

For product available in the USA/Canada market, only channel 1-11 can be operated. Selection of other channels is not possible.

Pour les produits disponibles aux États-Unis / Canada du marché, seul le canal 1 à 11 peuvent être exploités. Sélection d'autres canaux n'est pas possible.

High-power radars are allocated as primary users (i.e. priority users) of the bands 5250-5350 MHz and 5650-5850 MHz and that these radars could cause interference and/or damage to LE-LAN devices.

Les radars à haute puissance sont désignés comme utilisateurs principaux (c. utilisateurs prioritaires) des bandes 5250-5350 MHz et 5650-5850 MHz et que ces radars pourraient provoquer des interférences et / ou endommager les appareils LE- LAN.

Hazardous Substances

This product complies with the requirements of Directive 2011/65/EU of the European Parliament and of the Council of 8 June 2011 on the restriction of the use of certain hazardous substances in electrical and electronic equipment.

European Waste Electrical and Electronic Equipment (WEEE) Notice



In accordance with Directive 2012/19/EU of the European Parliament on waste electrical and electronic equipment (WEEE):

- The symbol above indicates that separate collection of electrical and electronic equipment is required.
- When this product has reached the end of its serviceable life, it cannot be disposed of as unsorted municipal waste. It must be collected and treated separately.
- It has been determined by the European Parliament that there are potential negative effects on the environment and human health as a result of the presence of hazardous substances in electrical and electronic equipment.
- It is the users' responsibility to utilize the available collection system to ensure WEEE is properly treated. For information about the available collection system, please contact Extreme Customer Support at +353 61 705500 (Ireland).

單元Unit	限用物質及其化學符號 Restricted substances and its chemical symbols					
	鉛Lead (Pb)	汞Mercury (Hg)	鎘Cadmium (Cd)	六價鉻 Hexavalent chromium (Cr ⁶⁺)	多溴聯苯 Polybrominated biphenyls (PBB)	多溴二苯醚 Polybrominated diphenyl ethers (PBDE)
金屬零件 (Metal Parts)	○	○	○	○	○	○
電路模組 (Circuit Modules)	—	○	○	○	○	○
電纜及電纜組件 (Cables & Cable Assemblies)	○	○	○	○	○	○
塑料和聚合物零件 (Plastic and Polymeric parts)	○	○	○	○	○	○
備考1. “超出0.1 wt %”及“超出0.01 wt %”係指限用物質之百分比含量超出百分比含量基準值。 Note 1: “Exceeding 0.1 wt %” and “exceeding 0.01 wt %” indicate that the percentage content of the restricted substance exceeds the reference percentage value of presence condition.						
備考2. “○”係指該項限用物質之百分比含量未超出百分比含量基準值。 Note 2: “○” indicates that the percentage content of the restricted substance does not exceed the percentage of reference value of presence.						
備考3. “—”係指該項限用物質為排除項目。 Note 3: The “—” indicates that the restricted substance corresponds to the exemption.						

NCC Statement

- 「經型式認證合格之低功率射頻電機，非經許可，公司、商號或使用者均不得擅自變更頻率、加大功率或變更原設計之特性及功能」。
- 「低功率射頻電機之使用不得影響飛航安全及干擾合法通信；經發現有干擾現象時，應立即停用，並改善至無干擾時方得繼續使用。前項合法通信，指依電信法規定作業之無線電通信。低功率射頻電機須忍受合法通信或工業、科學及醫療用電波輻射性電機設備之干擾」。
- 「電磁波曝露量 MPE 標準值 1mW/cm²，本產品使用時建議應距離人體：25 cm」。
- 「本器材須經專業工程人員安裝及設定，始得設置使用，且不得直接販售給一般消費者

Declaration of Conformity in Languages of the European Community

Hereby, Extreme Networks, Inc. declares that the radio equipment type Wireless LAN Access Point is in compliance with Directive 1999/5/EC. The full text of the EU declaration of conformity is available at the following internet address: <http://www.extremenetworks.com/>

Extreme Wireless™ Access Points

Quick Reference

P/N 31012 WS-AP3935i-FCC

P/N 31013 WS-AP3935i-ROW

P/N 31014 WS-AP3935e-FCC

P/N 31015 WS-AP3935e-ROW

P/N 31020 WS-AP3935i-IL