

ExtremeSwitching™

# Installation Job Aid for Ethernet Routing Switch 3600 Series

NN47213-303  
Issue 03.01  
November 2017

## Notices

Notice paragraphs alert you about issues that require your attention.

Following are descriptions of the types of notices used in this document.

 **Note:**

Notes provide tips and useful information regarding the installation and operation of products.

 **Electrostatic alert:**

ESD notices provide information about how to avoid discharge of static electricity and subsequent damage to products.

 **Caution:**

Caution notices provide information about how to avoid possible service disruption or damage to products.

 **Warning:**

Warning notices provide information about how to avoid personal injury when working with products.

 **Voltage:**

Danger—High Voltage notices provide information about how to avoid a situation or condition that can cause serious personal injury or death from high voltage or electric shock.

 **Danger:**

Danger notices provide information about how to avoid a situation or condition that can cause serious personal injury or death.

# Safety messages

Safety messages are an important part of the technical documentation. The messages alert you to hazards to personnel and equipment and provide guidance for the safe operation of your equipment. Failure to comply with the safety messages could result in equipment damage and personal injury.

Following are the most common types of safety messages.

 **Warning:**

Installation must be performed by qualified personnel only. Read and follow all warning notices and instructions marked on the product or included in the documentation.

 **Voltage:**

This equipment relies on the building's installation for overcurrent protection. Ensure that a fuse or circuit breaker no larger than 120 VAC, 15 A U.S. (240 VAC, 16 A International) is used on the phase conductors.

 **Caution:**

This device is a Class A product. In a domestic environment, this device can cause radio interference, in which case the user may be required to take appropriate measures.

 **Caution:**

When mounting this device in a rack, do not stack units directly on top of one another in the rack. Each unit must be secured to the rack with appropriate mounting brackets. Mounting brackets are not designed to support multiple units.

 **Voltage:**

Use only power cords that have a grounding path. Without a proper ground, a person who touches the switch is in danger of receiving an electrical shock. Lack of a grounding path to the switch can result in excessive emissions.

 **Warning:**

Disconnecting the power cord is the only way to turn off power to this device. Always connect the power cord in a location that can be reached quickly and safely in case of an emergency.

 **Warning:**

Fiber optic equipment can emit laser or infrared light that can injure your eyes. Never look into an optical fiber or connector port. Always assume that fiber optic cables are connected to a light source.



# AC power cord specifications

The following section outlines the AC power cord specifications for various countries. Ensure that you use the correct cord for your location.

**Table 1: International power cord specifications**

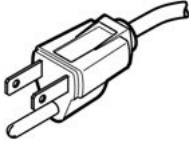
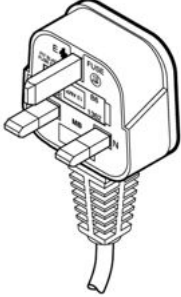
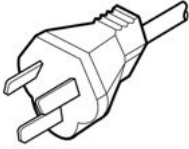
Country and plug description	Specifications	Typical plug
Continental Europe <ul style="list-style-type: none"> <li>• CEE7 standard VII male plug</li> <li>• Harmonized cord (HAR marking on the outside of the cord jacket to comply with the CENELEC Harmonized Document HD-21)</li> </ul>	220 or 230 VAC 50 Hz Single phase	 228FA
U.S./Canada/Japan <ul style="list-style-type: none"> <li>• NEMA5-15P male plug</li> <li>• UL-recognized (UL stamped on cord jacket)</li> <li>• CSA-certified (CSA label secured to the cord)</li> </ul>	100 or 120 VAC 50-60 Hz Single phase	 227FA
United Kingdom <ul style="list-style-type: none"> <li>• BS1363 male plug with fuse</li> <li>• Harmonized cord</li> </ul>	240 VAC 50 Hz Single phase	 229FA
Australia AS3112-1981 male plug	240 VAC 50 Hz Single phase	 230FA

# Before you begin

Ensure the area where you install and use the switch meets the following environmental requirements:

- Ambient temperature between 32°F and 122°F (0°C and 50°C).
- Relative humidity between 0% and 95% noncondensing.
- No nearby heat sources such as hot air vents or direct sunlight.
- No nearby sources of severe electromagnetic noise.
- No excessive dust.
- Adequate power source within six feet; one circuit required for each power supply.
- At least 2 inches (5.1 cm) (or one vertical rack width) on all sides of the switch unit for ventilation.
- Adequate space at the front and rear of the switch for access to cables.

If you are installing a single Ethernet Routing Switch on a table or shelf, ensure the surface can support at least 7 to 13 pounds (3 to 6 kilograms).

## Installation preparation

To prevent damage, handle the switch carefully by using the following guidelines:

- To prevent damage from electrostatic discharge, always wear an antistatic wrist strap connected to an ESD jack.
- Always place the switch on appropriate antistatic material.
- Support the switch from underneath with two hands. Do not touch components or connector pins with your hand, or damage can result.
- Do not over tighten screws. Tighten until snug. Do not use a power tool to tighten screws.

For information about technical specifications for the individual switches, see *Installing Ethernet Routing Switch 3600 Series*.

## Installing the switch

The following procedures describe how to install an ERS 3600 Series on a table or shelf, or in an equipment rack.

## Installing an ERS 3626GTS-PWR+ on a table or shelf

You can install the switch model ERS 3626GTS-PWR+ on a flat surface such as a table or shelf. The surface must be able to support the combined weight of the switch and attached cables. An ERS 3626GTS-PWR+ weighs 4.75kg (10.47lb).

### **Important:**

Allow at least 5.1 cm (2 inches) on each side of the switch for proper ventilation and at least 12.7 cm (5 inches) at the back of the switch for power cord clearance.

Ambient temperature when low power mode is used must be 30 degrees Celsius (86 F) or lower.

### **About this task**

The following procedure provides instructions for installing the switch on a table or shelf.

### **Procedure**

1. Insert the rubber feet at the bottom of the switch.

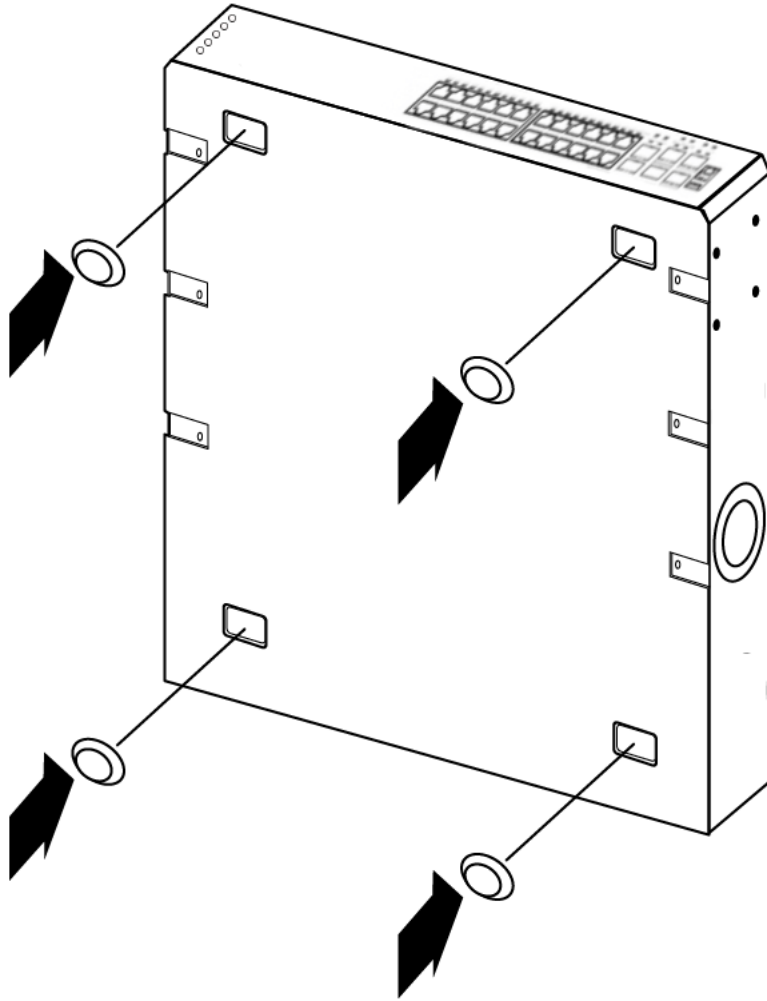

2. Set the switch on a table or shelf.

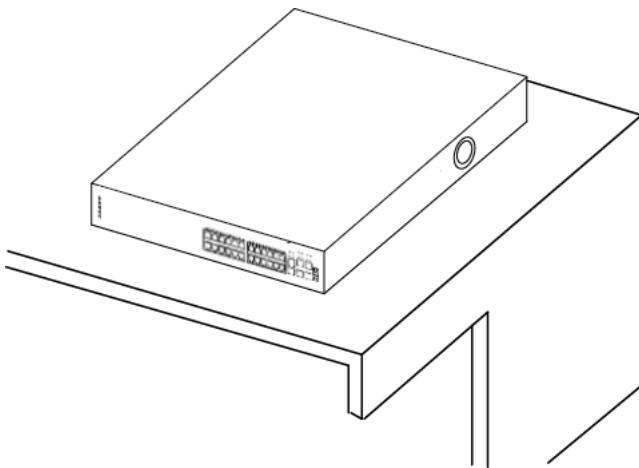

# Installing an ERS 3600 Series in an equipment rack

## Before you begin

Tool requirements:

- Phillips screwdriver to attach brackets to the switch and the switch to the rack.

## Rack requirements

- Space of 2.8 inches (7.1 centimeters) for each switch in an E1A or 1EC standard 19 inch (48.2 centimeter) equipment rack and T1A 23 inch (58.5 cm) equipment rack.
- Appropriate rack space to accommodate 1U switch height.
- Rack bolted to floor and braced if necessary.
- Rack must be grounded to the same grounding electrode used by the power service in the area. The ground path must be permanent and must not exceed 1 ohm of resistance from the rack to the grounding electrode.

## \* Note:

Extreme Networks does not supply the bolts used to secure the switch to the rack. Ensure you obtain the appropriate bolts to secure the switch to your specific rack before you begin.

## Procedure

1. Ensure power is disconnected from the switch.
2. Attach a front bracket to each guide bracket with four 8.5 mm length flat head machine screws.

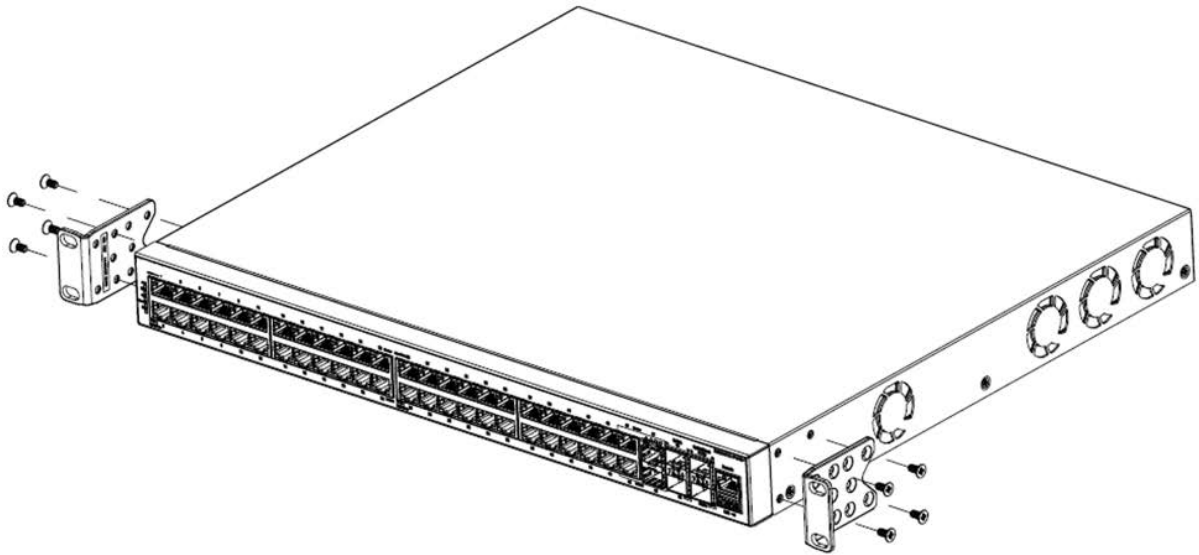

**Figure 1: Rack bracket installation**

3. Slide the switch into the rack. Insert and tighten the rack mount screws.

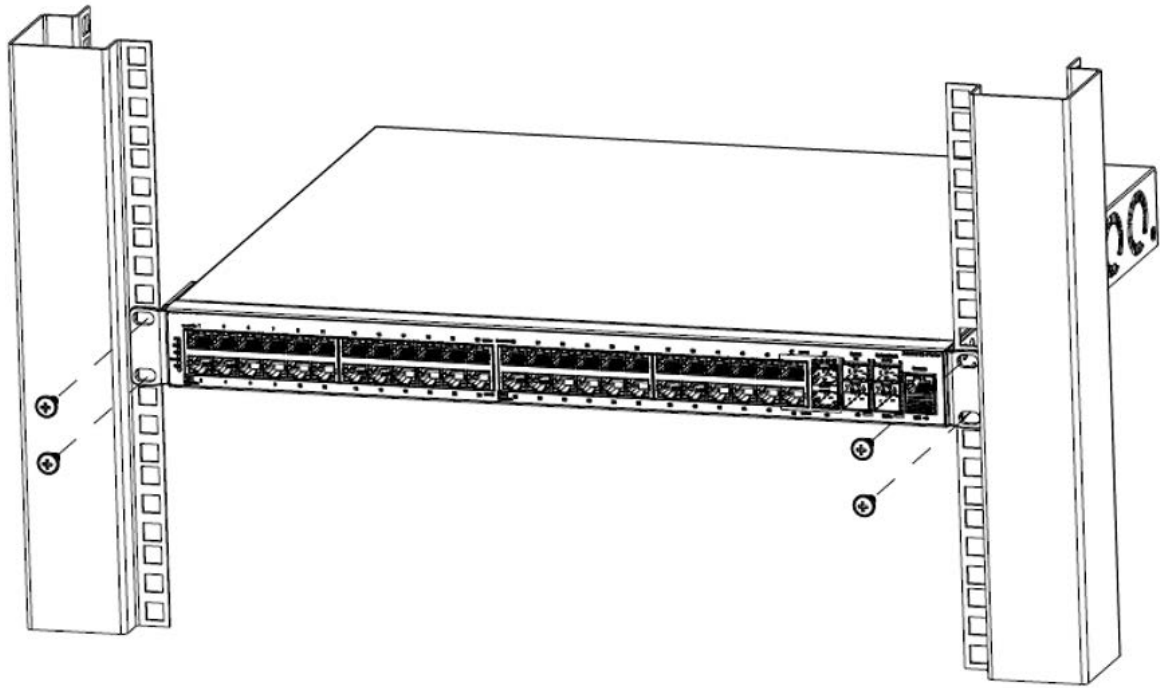

**Figure 2: Rack installation**

4. Verify that the switch is securely fastened to the rack.

## Connecting AC power

### Before you begin

- Ensure to check AC power specifications for the switch.
- Ensure to check the AC power cord for international use. You must use a power cord that is approved for the receptacle type in your country.

For more information, see [AC power cord specifications](#) on page 3.

### Procedure

1. Connect the AC power cord to the back of the switch, and then connect the cord to a power outlet.

**\* Note:**

ERS 3600 Series does not have a power switch. When you connect the AC power cord to a suitable AC power outlet, the switch powers up immediately.



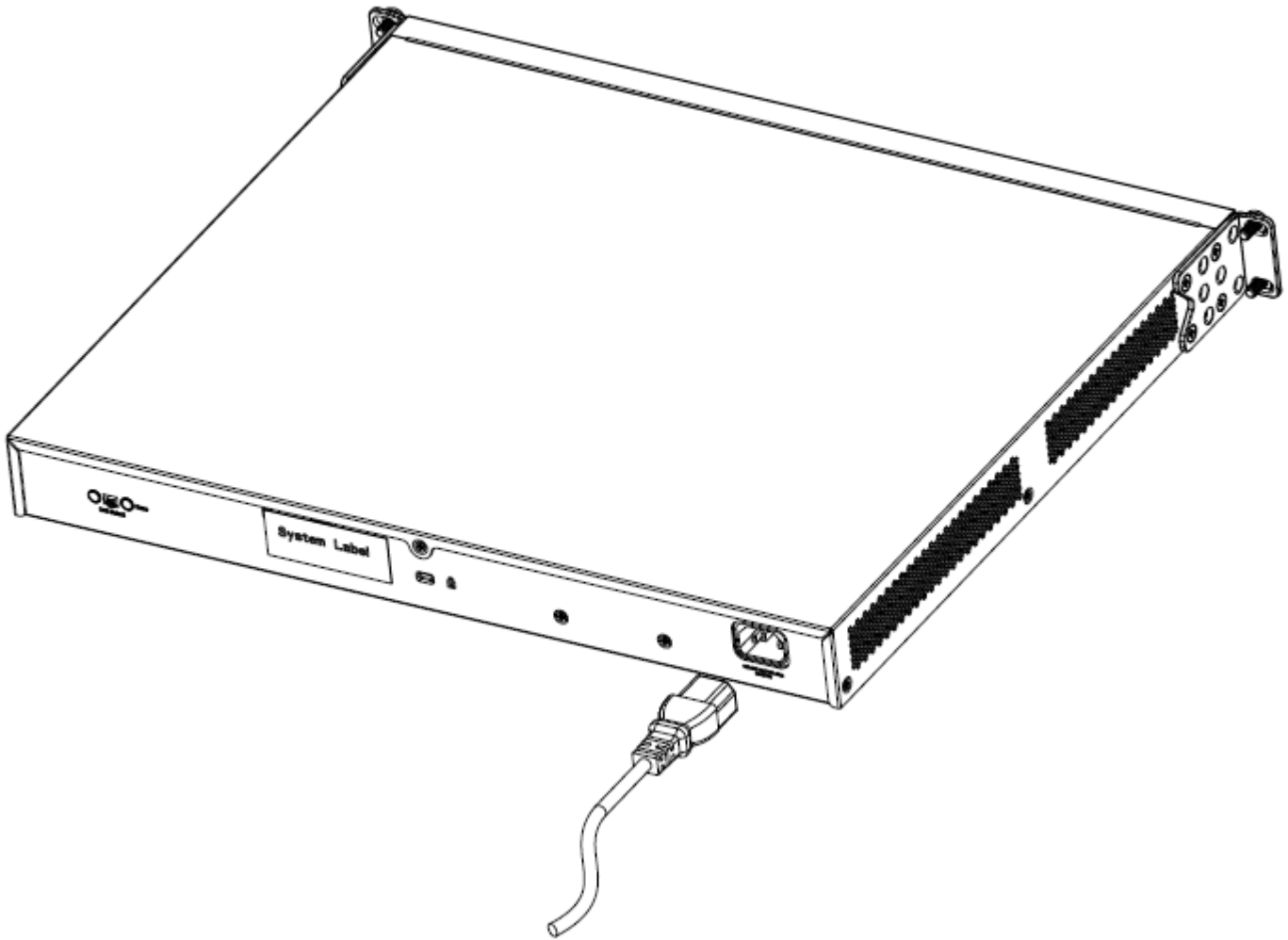

2. Check the front-panel LEDs as the device is powered on to be sure the PWR LED is lit. If not, check that the power cable is correctly plugged in.

Connect the AC power cord to the back of the switch, and then connect the cord to a power outlet.

**⚠ Danger:**

**Using power cords with a proper grounding path**

Use only power cords that have a grounding path. Without a proper ground, a person who touches the switch is in danger of receiving an electrical shock. Lack of a grounding path to the switch can result in excessive emissions.