



# **Installing Transceivers and Optical Components on Avaya Ethernet Routing Switch 4900 and 5900 Series**

Release 7.4  
NN47211-302  
Issue 05.02  
September 2017

© 2017, Avaya Inc.  
All Rights Reserved.

### Notice

While reasonable efforts have been made to ensure that the information in this document is complete and accurate at the time of printing, Avaya assumes no liability for any errors. Avaya reserves the right to make changes and corrections to the information in this document without the obligation to notify any person or organization of such changes.

### Documentation disclaimer

"Documentation" means information published in varying mediums which may include product information, operating instructions and performance specifications that are generally made available to users of products. Documentation does not include marketing materials. Avaya shall not be responsible for any modifications, additions, or deletions to the original published version of Documentation unless such modifications, additions, or deletions were performed by or on the express behalf of Avaya. End User agrees to indemnify and hold harmless Avaya, Avaya's agents, servants and employees against all claims, lawsuits, demands and judgments arising out of, or in connection with, subsequent modifications, additions or deletions to this documentation, to the extent made by End User.

### Link disclaimer

Avaya is not responsible for the contents or reliability of any linked websites referenced within this site or Documentation provided by Avaya. Avaya is not responsible for the accuracy of any information, statement or content provided on these sites and does not necessarily endorse the products, services, or information described or offered within them. Avaya does not guarantee that these links will work all the time and has no control over the availability of the linked pages.

### Warranty

Avaya provides a limited warranty on Avaya hardware and software. Refer to your sales agreement to establish the terms of the limited warranty. In addition, Avaya's standard warranty language, as well as information regarding support for this product while under warranty is available to Avaya customers and other parties through the Avaya Support website: <https://support.avaya.com/helpcenter/getGenericDetails?detailId=C20091120112456651010> under the link "Warranty & Product Lifecycle" or such successor site as designated by Avaya. Please note that if You acquired the product(s) from an authorized Avaya Channel Partner outside of the United States and Canada, the warranty is provided to You by said Avaya Channel Partner and not by Avaya.

"Hosted Service" means an Avaya hosted service subscription that You acquire from either Avaya or an authorized Avaya Channel Partner (as applicable) and which is described further in Hosted SAS or other service description documentation regarding the applicable hosted service. If You purchase a Hosted Service subscription, the foregoing limited warranty may not apply but You may be entitled to support services in connection with the Hosted Service as described further in your service description documents for the applicable Hosted Service. Contact Avaya or Avaya Channel Partner (as applicable) for more information.

### Hosted Service

THE FOLLOWING APPLIES ONLY IF YOU PURCHASE AN AVAYA HOSTED SERVICE SUBSCRIPTION FROM AVAYA OR AN AVAYA CHANNEL PARTNER (AS APPLICABLE), THE TERMS OF USE FOR HOSTED SERVICES ARE AVAILABLE ON THE AVAYA WEBSITE, [HTTPS://SUPPORT.AVAYA.COM/LICENSEINFO](https://support.avaya.com/LicenseInfo) UNDER THE LINK "Avaya Terms of Use for Hosted Services" OR SUCH SUCCESSOR SITE AS DESIGNATED BY AVAYA, AND ARE APPLICABLE TO ANYONE WHO ACCESSES OR USES THE HOSTED SERVICE. BY ACCESSING OR USING THE HOSTED SERVICE, OR AUTHORIZING OTHERS TO DO SO, YOU, ON BEHALF OF YOURSELF AND THE ENTITY FOR WHOM YOU ARE DOING SO (HEREINAFTER REFERRED TO INTERCHANGEABLY AS "YOU" AND "END USER"), AGREE TO THE TERMS OF USE. IF YOU ARE ACCEPTING THE TERMS OF USE ON BEHALF A COMPANY OR OTHER LEGAL ENTITY, YOU REPRESENT THAT YOU HAVE THE AUTHORITY TO BIND SUCH ENTITY TO THESE TERMS OF USE. IF YOU DO NOT HAVE SUCH AUTHORITY, OR IF

YOU DO NOT WISH TO ACCEPT THESE TERMS OF USE, YOU MUST NOT ACCESS OR USE THE HOSTED SERVICE OR AUTHORIZE ANYONE TO ACCESS OR USE THE HOSTED SERVICE.

### Licenses

THE SOFTWARE LICENSE TERMS AVAILABLE ON THE AVAYA WEBSITE, [HTTPS://SUPPORT.AVAYA.COM/LICENSEINFO](https://support.avaya.com/LicenseInfo), UNDER THE LINK "AVAYA SOFTWARE LICENSE TERMS (Avaya Products)" OR SUCH SUCCESSOR SITE AS DESIGNATED BY AVAYA, ARE APPLICABLE TO ANYONE WHO DOWNLOADS, USES AND/OR INSTALLS AVAYA SOFTWARE, PURCHASED FROM AVAYA INC., ANY AVAYA AFFILIATE, OR AN AVAYA CHANNEL PARTNER (AS APPLICABLE) UNDER A COMMERCIAL AGREEMENT WITH AVAYA OR AN AVAYA CHANNEL PARTNER. UNLESS OTHERWISE AGREED TO BY AVAYA IN WRITING, AVAYA DOES NOT EXTEND THIS LICENSE IF THE SOFTWARE WAS OBTAINED FROM ANYONE OTHER THAN AVAYA, AN AVAYA AFFILIATE OR AN AVAYA CHANNEL PARTNER; AVAYA RESERVES THE RIGHT TO TAKE LEGAL ACTION AGAINST YOU AND ANYONE ELSE USING OR SELLING THE SOFTWARE WITHOUT A LICENSE. BY INSTALLING, DOWNLOADING OR USING THE SOFTWARE, OR AUTHORIZING OTHERS TO DO SO, YOU, ON BEHALF OF YOURSELF AND THE ENTITY FOR WHOM YOU ARE INSTALLING, DOWNLOADING OR USING THE SOFTWARE (HEREINAFTER REFERRED TO INTERCHANGEABLY AS "YOU" AND "END USER"), AGREE TO THESE TERMS AND CONDITIONS AND CREATE A BINDING CONTRACT BETWEEN YOU AND AVAYA INC. OR THE APPLICABLE AVAYA AFFILIATE ("AVAYA").

Avaya grants You a license within the scope of the license types described below, with the exception of Heritage Nortel Software, for which the scope of the license is detailed below. Where the order documentation does not expressly identify a license type, the applicable license will be a Designated System License. The applicable number of licenses and units of capacity for which the license is granted will be one (1), unless a different number of licenses or units of capacity is specified in the documentation or other materials available to You. "Software" means computer programs in object code, provided by Avaya or an Avaya Channel Partner, whether as stand-alone products, pre-installed on hardware products, and any upgrades, updates, patches, bug fixes, or modified versions thereto. "Designated Processor" means a single stand-alone computing device. "Server" means a Designated Processor that hosts a software application to be accessed by multiple users. "Instance" means a single copy of the Software executing at a particular time: (i) on one physical machine; or (ii) on one deployed software virtual machine ("VM") or similar deployment.

### License types

Designated System(s) License (DS). End User may install and use each copy or an Instance of the Software only on a number of Designated Processors up to the number indicated in the order. Avaya may require the Designated Processor(s) to be identified in the order by type, serial number, feature key, Instance, location or other specific designation, or to be provided by End User to Avaya through electronic means established by Avaya specifically for this purpose.

### Heritage Nortel Software

"Heritage Nortel Software" means the software that was acquired by Avaya as part of its purchase of the Nortel Enterprise Solutions Business in December 2009. The Heritage Nortel Software is the software contained within the list of Heritage Nortel Products located at <https://support.avaya.com/LicenseInfo> under the link "Heritage Nortel Products" or such successor site as designated by Avaya. For Heritage Nortel Software, Avaya grants Customer a license to use Heritage Nortel Software provided hereunder solely to the extent of the authorized activation or authorized usage level, solely for the purpose specified in the Documentation, and solely as embedded in, for execution on, or for communication with Avaya equipment. Charges for Heritage Nortel Software may be based on extent of activation or use authorized as specified in an order or invoice.

### Copyright

Except where expressly stated otherwise, no use should be made of materials on this site, the Documentation, Software, Hosted Service, or hardware provided by Avaya. All content on this site, the

documentation, Hosted Service, and the product provided by Avaya including the selection, arrangement and design of the content is owned either by Avaya or its licensors and is protected by copyright and other intellectual property laws including the sui generis rights relating to the protection of databases. You may not modify, copy, reproduce, republish, upload, post, transmit or distribute in any way any content, in whole or in part, including any code and software unless expressly authorized by Avaya. Unauthorized reproduction, transmission, dissemination, storage, and or use without the express written consent of Avaya can be a criminal, as well as a civil offense under the applicable law.

### Virtualization

The following applies if the product is deployed on a virtual machine. Each product has its own ordering code and license types. Note that each Instance of a product must be separately licensed and ordered. For example, if the end user customer or Avaya Channel Partner would like to install two Instances of the same type of products, then two products of that type must be ordered.

### Third Party Components

"Third Party Components" mean certain software programs or portions thereof included in the Software or Hosted Service may contain software (including open source software) distributed under third party agreements ("Third Party Components"), which contain terms regarding the rights to use certain portions of the Software ("Third Party Terms"). As required, information regarding distributed Linux OS source code (for those products that have distributed Linux OS source code) and identifying the copyright holders of the Third Party Components and the Third Party Terms that apply is available in the products, Documentation or on Avaya's website at: <https://support.avaya.com/Copyright> or such successor site as designated by Avaya. The open source software license terms provided as Third Party Terms are consistent with the license rights granted in these Software License Terms, and may contain additional rights benefiting You, such as modification and distribution of the open source software. The Third Party Terms shall take precedence over these Software License Terms, solely with respect to the applicable Third Party Components to the extent that these Software License Terms impose greater restrictions on You than the applicable Third Party Terms.

The following applies only if the H.264 (AVC) codec is distributed with the product. THIS PRODUCT IS LICENSED UNDER THE AVC PATENT PORTFOLIO LICENSE FOR THE PERSONAL USE OF A CONSUMER OR OTHER USES IN WHICH IT DOES NOT RECEIVE REMUNERATION TO (i) ENCODE VIDEO IN COMPLIANCE WITH THE AVC STANDARD ("AVC VIDEO") AND/OR (ii) DECODE AVC VIDEO THAT WAS ENCODED BY A CONSUMER ENGAGED IN A PERSONAL ACTIVITY AND/OR WAS OBTAINED FROM A VIDEO PROVIDER LICENSED TO PROVIDE AVC VIDEO. NO LICENSE IS GRANTED OR SHALL BE IMPLIED FOR ANY OTHER USE. ADDITIONAL INFORMATION MAY BE OBTAINED FROM MPEG LA, L.L.C. SEE [HTTP://WWW.MPEGLA.COM](http://www.mpegla.com).

### Service Provider

THE FOLLOWING APPLIES TO AVAYA CHANNEL PARTNER'S HOSTING OF AVAYA PRODUCTS OR SERVICES. THE PRODUCT OR HOSTED SERVICE MAY USE THIRD PARTY COMPONENTS SUBJECT TO THIRD PARTY TERMS AND REQUIRE A SERVICE PROVIDER TO BE INDEPENDENTLY LICENSED DIRECTLY FROM THE THIRD PARTY SUPPLIER. AN AVAYA CHANNEL PARTNER'S HOSTING OF AVAYA PRODUCTS MUST BE AUTHORIZED IN WRITING BY AVAYA AND IF THOSE HOSTED PRODUCTS USE OR EMBED CERTAIN THIRD PARTY SOFTWARE, INCLUDING BUT NOT LIMITED TO MICROSOFT SOFTWARE OR CODECS, THE AVAYA CHANNEL PARTNER IS REQUIRED TO INDEPENDENTLY OBTAIN ANY APPLICABLE LICENSE AGREEMENTS, AT THE AVAYA CHANNEL PARTNER'S EXPENSE, DIRECTLY FROM THE APPLICABLE THIRD PARTY SUPPLIER.

WITH RESPECT TO CODECS, IF THE AVAYA CHANNEL PARTNER IS HOSTING ANY PRODUCTS THAT USE OR EMBED THE G.729 CODEC, H.264 CODEC, OR H.265 CODEC, THE AVAYA CHANNEL PARTNER ACKNOWLEDGES AND AGREES THE AVAYA CHANNEL PARTNER IS RESPONSIBLE FOR ANY AND ALL RELATED FEES AND/OR ROYALTIES. THE G.729 CODEC IS LICENSED BY SIPRO LAB TELECOM INC. SEE [WWW.SIPRO.COM/CONTACT.HTML](http://www.sipro.com/contact.html). THE H.264 (AVC) CODEC IS

LICENSED UNDER THE AVC PATENT PORTFOLIO LICENSE FOR THE PERSONAL USE OF A CONSUMER OR OTHER USES IN WHICH IT DOES NOT RECEIVE REMUNERATION TO: (I) ENCODE VIDEO IN COMPLIANCE WITH THE AVC STANDARD ("AVC VIDEO") AND/OR (II) DECODE AVC VIDEO THAT WAS ENCODED BY A CONSUMER ENGAGED IN A PERSONAL ACTIVITY AND/OR WAS OBTAINED FROM A VIDEO PROVIDER LICENSED TO PROVIDE AVC VIDEO. NO LICENSE IS GRANTED OR SHALL BE IMPLIED FOR ANY OTHER USE. ADDITIONAL INFORMATION FOR H.264 (AVC) AND H.265 (HEVC) CODECS MAY BE OBTAINED FROM MPEG LA, L.L.C. SEE [HTTP://WWW.MPEGLA.COM](http://www.mpegla.com).

### Compliance with Laws

You acknowledge and agree that it is Your responsibility for complying with any applicable laws and regulations, including, but not limited to laws and regulations related to call recording, data privacy, intellectual property, trade secret, fraud, and music performance rights, in the country or territory where the Avaya product is used.

### Preventing Toll Fraud

"Toll Fraud" is the unauthorized use of your telecommunications system by an unauthorized party (for example, a person who is not a corporate employee, agent, subcontractor, or is not working on your company's behalf). Be aware that there can be a risk of Toll Fraud associated with your system and that, if Toll Fraud occurs, it can result in substantial additional charges for your telecommunications services.

### Avaya Toll Fraud intervention

If You suspect that You are being victimized by Toll Fraud and You need technical assistance or support, call Technical Service Center Toll Fraud Intervention Hotline at +1-800-643-2353 for the United States and Canada. For additional support telephone numbers, see the Avaya Support website: <https://support.avaya.com> or such successor site as designated by Avaya.

### Security Vulnerabilities

Information about Avaya's security support policies can be found in the Security Policies and Support section of <https://support.avaya.com/security>.

Suspected Avaya product security vulnerabilities are handled per the Avaya Product Security Support Flow (<https://support.avaya.com/css/P8/documents/100161515>).

### Downloading Documentation

For the most current versions of Documentation, see the Avaya Support website: <https://support.avaya.com>, or such successor site as designated by Avaya.

### Contact Avaya Support

See the Avaya Support website: <https://support.avaya.com> for product or Hosted Service notices and articles, or to report a problem with your Avaya product or Hosted Service. For a list of support telephone numbers and contact addresses, go to the Avaya Support website: <https://support.avaya.com> (or such successor site as designated by Avaya), scroll to the bottom of the page, and select Contact Avaya Support.

### Trademarks

The trademarks, logos and service marks ("Marks") displayed in this site, the Documentation, Hosted Service(s), and product(s) provided by Avaya are the registered or unregistered Marks of Avaya, its affiliates, its licensors, its suppliers, or other third parties. Users are not permitted to use such Marks without prior written consent from Avaya or such third party which may own the Mark. Nothing contained in this site, the Documentation, Hosted Service(s) and product(s) should be construed as granting, by implication, estoppel, or otherwise, any license or right in and to the Marks without the express written permission of Avaya or the applicable third party.

Avaya is a registered trademark of Avaya Inc.

All non-Avaya trademarks are the property of their respective owners. Linux<sup>®</sup> is the registered trademark of Linus Torvalds in the U.S. and other countries.

# Contents

<b>Chapter 1: Introduction</b> .....	6
Purpose.....	6
<b>Chapter 2: New in this document</b> .....	7
10GBASE-T SFP+ transceiver.....	7
<b>Chapter 3: Safety and equipment care information</b> .....	8
Fiber optic equipment care.....	8
Fiber optic cable care.....	8
Fiber optic connector care.....	9
Cleaning single connectors.....	10
Cleaning duplex connectors.....	11
Cleaning receptacles.....	12
<b>Chapter 4: Supported transceivers and DACs information</b> .....	14
Supported transceivers.....	14
Supported SFP transceivers.....	14
Supported SFP+ transceivers.....	15
Supported DACs.....	15
SFP+ DAC specifications.....	16
QSFP+ DAC specifications.....	16
<b>Chapter 5: SFP</b> .....	17
SFP transceiver.....	17
Selecting an SFP.....	17
Installing an SFP.....	18
Removing an SFP.....	19
SFP specifications.....	20
SFP labels.....	20
General SFP specifications.....	21
Supported SFP transceivers.....	21
<b>Chapter 6: SFP+</b> .....	26
SFP+ transceivers.....	26
Selecting an SFP+.....	26
Installing an SFP+.....	27
Removing an SFP+.....	29
SFP+ specifications.....	29
SFP+ labels.....	30
General SFP+ specifications.....	30
Supported SFP+ transceivers.....	31
<b>Chapter 7: End of sale transceivers and cables</b> .....	41
Locating end of sale notices.....	41
End of sale SFP transceivers.....	41

End of sale SFP+ transceivers.....	42
<b>Chapter 8: Translation of safety messages.....</b>	<b>43</b>
Class A electromagnetic interference warning statement.....	43
Electrostatic discharge warning statement.....	44
Laser eye safety danger statement.....	45
Laser eye safety connector inspection danger statement.....	46
Connector cleaning safety danger statement.....	47
Optical fiber damage warning statement.....	48
Optical fiber connector damage warning statement.....	49
SFP damage warning statement.....	51
<b>Chapter 9: Resources.....</b>	<b>53</b>
Support.....	53
Searching a documentation collection.....	54
Subscribing to e-notifications.....	55
<b>Glossary.....</b>	<b>58</b>

# Chapter 1: Introduction

---

## Purpose

This document provides information on features in the following products:

- Ethernet Routing Switch 4900 Series
- Ethernet Routing Switch 5900 Series

You can use this document to help you select, install, and remove Small Form Factor Pluggable (SFP) and Small Form Factor Pluggable Plus (SFP+) transceivers. Specifications for each supported device are also included.

# Chapter 2: New in this document

The following sections detail what is new in *Installing Transceivers and Optical Components on Avaya Ethernet Routing Switch 4900 and 5900 Series*, NN47211-302.

---

## 10GBASE-T SFP+ transceiver

The 10GBASE-T SFP+ transceiver provides 10 Gigabit Ethernet connectivity using a single eight pin RJ-45 connector. The part number for this model is AA1403043-E6.

For more information, see [10GBASE-T SFP+ transceiver](#) on page 31.

# Chapter 3: Safety and equipment care information

This chapter contains important safety and regulatory information. Read this section before you install Small Form Factor Pluggable (SFP) or Small Form Factor Pluggable Plus (SFP+) transceivers.

---

## Fiber optic equipment care

Use the information in this section to properly maintain and care for fiber optic equipment.

Transceivers are static sensitive.

Dust contamination can reduce the performance of optical parts in transceivers. When you store a transceiver, or after you disconnect it from a fiber optic cable, always keep a dust cover over the optical bore.

Dispose of this product according to all national laws and regulations.

To prevent equipment damage, observe the following electrostatic discharge (ESD) precautions when you handle or install the components:

- Ground yourself and the equipment to an earth or building ground. Use a grounded workbench mat (or foam that dissipates static charge) and a grounding wrist strap. The wrist strap must touch the skin and you must ground it through a one megaohm resistor.
- Do not touch anyone who is not grounded
- Leave all components in their ESD-safe packaging until installation, and use only a static-shielding bag for all storage, transport, and handling.

Clear the area of synthetic materials such as polyester, plastic, vinyl, or styrofoam because these materials carry static electricity that damages the equipment.

---

## Fiber optic cable care

Although reinforcing material and plastic insulation protects the glass fiber in fiber optic cable, it is subject to damage.



Use the following precautions to avoid damaging the glass fiber:

- Do not kink, knot, or vigorously flex the cable.
- Do not bend the cable to less than a 40 mm radius.
- Do not stand on fiber optic cable; keep the cable off the floor.
- Do not pull fiber optic cable harder than you do a cable containing copper wire of comparable size.
- Do not allow a static load of more than a few pounds on a section of the cable.
- Place protective caps on fiber optic connectors that are not in use.
- Store unused fiber optic patch cables in a cabinet, on a cable rack, or flat on a shelf.

Frequent overstressing of fiber optic cable causes progressive degeneration that leads to failure.

If you suspect damage to a fiber optic cable, either due to mishandling or an abnormally high error rate observed in one direction, reverse the cable pairs. If the high error rate appears in the other direction, replace the cable.

 **Warning:**

**Risk of equipment damage**

Do not crush fiber optic cable. If fiber optic cable is in the same tray or duct with large, heavy electrical cables, the weight of the electrical cable can damage the fiber optic cable.

---

## Fiber optic connector care

Before you connect fiber optic connectors to transmission equipment, test equipment, patch panels, or other connectors, ensure fiber optic connectors are clean. The performance of an optical fiber connector depends on how clean the connector and coupling are at the time of connection.

A damaged or dirty connector can damage a connector with which it pairs. A connector must be clean before you insert it into a transmitter or receiver.

Never clean an optical connector while it carries light. Optical power can cause ignition of the cleaning material when it contacts the end of the optical connector and can destroy the connector. Typical cleaning materials, for example, tissues saturated with alcohol, combust almost instantaneously after you expose them to optical power levels of +15 dBm or higher.

Visually inspect the connector to determine cleanliness and to determine if it needs replacing. You must replace a connector that has a scratch across the core, or a scratch that appears to end in the core.

The proper connector cleaning method depends on the connector contaminants:

- Judge cleanliness by visual inspection with a fiber microscope. First inspect the connector, and then clean as required.

 **Danger:**

**Risk of eye injury**

When you inspect a connector, ensure that light sources are off. The light source in fiber optic cables can damage your eyes.

- If you suspect only the possibility of dust particles, for example, if you leave a connector uncapped in a clean environment, use high-quality canned air or a reel cleaner, for example, a Cletop, to clean the connector. A reel cleaner is a good choice to ensure that no dust contaminates the connector.
- If the connector is visibly dirty or you suspect contamination by chemicals (for example, matching gel), use high-quality alcohol and canned air to clean the connector. This method is the most thorough cleaning method. In some cases, a reel cleaner can suffice.

The more surface manipulation you apply to the connector, the more likely you are to damage the connector.

When you insert a connector ferrule into a connector or adapter, ensure that the ferrule tip does not touch the outside of the mating connector or adapter. This action can produce scratches and dirt deposits on the connector.

To help prevent connectors from collecting dust, cover them when not in use. To avoid the transfer of oil or other contaminants from your fingers to the end face of the ferrule, handle connectors with care. Do not touch the connector end face.

---

## Cleaning single connectors

Clean connectors so that the optical signal is minimally attenuated by the connector.

Perform this procedure if you suspect more than dust contamination.

### Before you begin

- You need a lens-grade, lint-free tissue, for example, Kimwipes.
- You need an optical-grade isopropyl alcohol (IPA) (98% or more pure).
- You need a high-quality canned compressed air with extension tube.

Compressed air must be free of dust, water, and oil, or filmy deposits or scratches on the surface of the connector can result.

- You need a fiber optic microscope to inspect connectors.

 **Danger:**

**Risk of eye injury**

When you inspect a connector, ensure that light sources are off. The light source used in fiber optic cables can damage your eyes.

To avoid getting debris in your eyes, wear safety glasses when you work with the canned air duster.

To avoid eye irritation on contact, wear safety glasses when you work with isopropyl alcohol.

### Procedure

1. Remove dust or debris by applying canned air to the cylindrical and end-face surfaces of the connector.
2. Gently wipe the cylindrical and end-face surfaces with a tissue dampened with optical-grade isopropyl alcohol.
3. Gently wipe the cylindrical and end-face surfaces with a dry tissue.

#### **Important:**

Do not let the IPA evaporate; wipe it dry immediately. Alcohols can leave a residue that is difficult to remove.

4. Dry the connector surfaces by applying canned air.
5. Inspect the connector to ensure it is clean and undamaged.

To prevent contamination, do not touch the connector surfaces after cleaning; and cover connectors with dust caps if they are not in use.

---

## Cleaning duplex connectors

Clean connectors so that the optical signal is minimally attenuated by the connector.

Perform this procedure when you suspect more than dust contamination.

### Before you begin

- You need a lens-grade, lint-free tissue, for example, Kimwipes.
- You need an optical-grade isopropyl alcohol (IPA) (98% or more pure).
- You need a high-quality canned compressed air with extension tube.

Compressed air must be free of dust, water, and oil, or filmy deposits or scratches on the surface of the connector can result.

- You need a fiber optic microscope to inspect connectors.

### About this task

#### **Danger:**

#### **Risk of eye injury**

When you inspect a connector, ensure that light sources are off. The light source in fiber optic cables can damage your eyes.

To avoid getting debris in your eyes, wear safety glasses when you work with the canned air duster.

To avoid eye irritation on contact, wear safety glasses when you work with isopropyl alcohol.

## Procedure

1. Remove or retract the shroud.

On removable shroud connectors, hold the shroud on the top and bottom at the letter designation, apply medium pressure, and then pull it free from the connector body. Do not discard the shroud.

### OR

On retractable shroud connectors, hold the shroud in the retracted position.

2. Remove dust or debris by applying canned air to the cylindrical and end-face surfaces of the connector.
3. Gently wipe the cylindrical and end-face surfaces of both ferrules using a tissue saturated with optical-grade isopropyl alcohol.
4. Gently wipe the cylindrical and end-face surfaces with a dry tissue.

### Important:

Do not let the IPA evaporate; wipe it dry immediately. Alcohols can leave a residue that is difficult to remove.

5. Blow dry the connector surfaces with canned air.
6. Inspect the connector to ensure it is clean and undamaged.
7. Using care to not touch the clean ferrules, gently push the shroud back onto the connector until it seats and locks in place.

---

## Cleaning receptacles

Clean connector receptacles or ports so that the optical signal is minimally attenuated by the connection.

### Before you begin

- You need an optical-grade isopropyl alcohol (IPA) (98% or more pure).
- You need cleaning swabs (also called cleaning sticks or wands).
- You need a high-quality canned compressed air with extension tube.

Compressed air must be free of dust, water, and oil, or filmy deposits or scratches on the surface of the connector can result.

### Warning:

#### Risk of equipment damage

To avoid contamination, only clean optical ports if you see evidence of contamination or reduced performance exists, or during their initial installation.

To prevent oil contamination of connectors, use only high-quality canned compressed air.

Do not allow the air extension tube to touch the bottom of the optical port.

### Procedure

1. Remove dust or debris by blowing canned air into the optical port of the device using the canned air extension tube.
2. Clean the optical port by inserting a wand moistened with alcohol into the receptacle and rotating it.

Use each cleaning wand to clean only one optical port.

3. Dry the optical port by inserting a dry wand into the receptacle and rotating it.

#### **Important:**

Do not let the IPA evaporate; wipe it dry immediately. Alcohols can leave a residue that is difficult to remove.

4. Remove lint by blowing compressed air into the optical port.
5. Reconnect the optical connector and check for proper function.

If you do not reinstall the connector, use a protective cap.

If problems persist, ensure that the connector or receptacle is free from damage.

# Chapter 4: Supported transceivers and DACs information

---

## Supported transceivers

The following tables list supported SFP and SFP+ transceivers for the Avaya Ethernet Routing Switch 4900 and 5900 Series.

The following tables display only transceivers that are currently supported and available in the price book. Some transceivers might have gone end-of-sale (EOS). For more information, see [End of sale transceivers and cables](#) on page 41.

**!** **Important:**

Avaya recommends that you use Avaya-branded SFP, SFP+, and QSFP+ transceivers as they have been through extensive qualification and testing. Avaya will not be responsible for issues related to non-Avaya branded transceivers.

---

## Supported SFP transceivers

The following table describes the reach provided by various SFP transceivers. This table is informational only — not all Ethernet switching and routing products support all the SFP transceivers listed here.

**Table 1: Supported SFP transceivers**

Model	Description	Part number	Minimum software version	
			ERS 5900	ERS 4900
1000BASE-T SFP	Gigabit Ethernet, RJ-45 connector	AA1419043-E6	7.0	7.1
1000BASE-SX DDI SFP	850 nm, Gigabit Ethernet, duplex LC connector	AA1419048-E6	7.0	7.1
1000BASE-LX DDI SFP	1310 nm, Gigabit Ethernet, duplex LC connector	AA1419049-E6	7.0	7.1
1000BASE-BX10 DDI SFP	1310 nm (tx) and 1490 nm (rx),	AA1419069-E6 (10 km at 1310 nm )	7.0	7.1

Model	Description	Part number	Minimum software version	
			ERS 5900	ERS 4900
	Gigabit Ethernet, single-fiber LC connector	and mating pair AA1419070–E6 (10 km at 1490 nm)		

## Supported SFP+ transceivers

SFP+ transceivers are hot-swappable input and output enhancement components that allow 10-Gigabit connections.

All SFP+ transceivers use LC connectors to provide precision keying and low interface losses.

The following table lists and describes the SFP+ transceiver models.

Model	Description	Part number	Minimum software version	
			ERS 5900	ERS 4900
10GBASE-SR/SW SFP+	850 nm MMF	AA1403015–E6	7.0	7.1
10GBASE-LRM SFP+	220 m, 1260 to 1355 nm; 1310 nm nominal MMF	AA1403017–E6	7.0	7.1
10GBASE-LR/LW SFP+	10 km, 1310 nm SMF	AA1403011–E6	7.0	7.1
10GBASE-ER/EW SFP+	40 km, 1550 nm SMF	AA1403013–E6	7.0	7.1
10GBASE-ZR/ZW SFP+	70 km, 1550 nm SMF	AA1403016–E6	7.0	7.1
10GBASE-T SFP+	30 m, over Cat 6a/7 cable	AA1403043–E6	7.4	7.4
10GBASE CWDM DDI SFP+ (40 km)	40 km, 1471 to 1611 nm	AA1403153–E6 to AA1403160–E6	7.1	7.1
10GBASE CWDM DDI SFP+ (70 km)	70 km, 1471 to 1611 nm	AA1403161–E6 to AA1403168–E6	7.1	7.1
10GBASE-BX10 SFP+	10 km	AA1403169–E6 and AA1403170–E6	7.1	7.1

## Supported DACs

The following table shows the supported direct attach cables (DAC).

## SFP+ DAC specifications

The following table provides a list of the supported SFP+ direct attach cables (DAC).

Cable type	Cable length	Part number	Minimum software version	
			ERS 5900	ERS 4900
10GBASE-CX SFP + DAC 2-pair twinaxial copper cable	SFP+ DAC 3 meter	AA1403019-E6	7.0	7.1
10GBASE-CX SFP + DAC 2-pair twinaxial copper cable	SFP+ DAC 5 meter	AA1403020-E6	7.0	7.1
10GBASE-CX SFP + DAC 2-pair twinaxial copper cable	SFP+ DAC 10 meter	AA1403018-E6	7.0	7.1

## QSFP+ DAC specifications

The following table provides a list of the supported QSFP+ direct attach cables (DAC).

Cable type	Cable length	Part number	Minimum software version
			ERS 5900
QSFP+ to QSFP+ 40 Gigabit DAC—active			
Active optical DAC	QSFP+ to QSFP+ 10 meter	AA1404028-E6	7.5



# Chapter 5: SFP

This chapter provides installation procedures and specifications for small form factor pluggable (SFP) transceivers.

Use an SFP transceiver to connect a device motherboard to a fiber optic or unshielded twisted pair network cable. The SFP transceivers described in this section provide Ethernet at 1 gigabit per second (Gbps).

---

## SFP transceiver

This section describes how to select and install small form factor pluggable (SFP) transceivers.

Use an SFP transceiver to connect a device motherboard to a fiber optic or unshielded twisted pair network cable. The SFP transceivers described in this section provide Ethernet at 1 gigabit per second (Gbps).

---

## Selecting an SFP

Use an SFP transceiver to connect a device motherboard to a fiber optic or unshielded twisted pair network cable. Select the appropriate transceiver to provide the required reach.

### Procedure

1. Determine the required reach.

Depending on the product, SFP transceivers are available for cable distances of up to 100 meters (m), 550 m, 10 kilometers (km), 40 km, 70 km, and 120 km.

2. Determine the required media and connector type.

You need fiber optic cable for a reach over 100 m.

Possible media include CAT5, single mode fiber, and multimode fiber. Possible connectors include LC, MT-RJ, and RJ-45.

3. If the media is optical fiber, determine wavelength restrictions or requirements.

To expand available bandwidth on a common optical fiber, use Coarse Wavelength Division Multiplexing (CWDM) SFP transceivers.

4. Determine if you need digital diagnostic monitoring (DDM). DDM is enabled by default.

Not all SFP transceivers or products support DDM.

---

## Installing an SFP

Install an SFP to provide an interface between the device and the network cable.

### Before you begin

- Verify that the SFP is the correct model for your network configuration.
- Before you install the fiber, ensure that the connector is clean.

#### **Danger:**

##### **Risk of eye injury by laser**

Fiber optic equipment can emit laser or infrared light that can injure your eyes. Never look into an optical fiber or connector port. Always assume that fiber optic cables are connected to a light source.

#### **Electrostatic alert:**

ESD can damage electronic circuits. Do not touch electronic hardware unless you wear a grounding wrist strap or other static-dissipating device.

#### **Warning:**

##### **Risk of equipment damage**

Only trained personnel can install this product.

### About this task

Installing an SFP takes approximately 3 minutes.

### Procedure

1. Remove the SFP from its protective packaging.
2. Grasp the SFP transceiver between your thumb and forefinger.
3. Insert the device into the port on the module.

Depending on the module type, you must insert some SFP transceivers into the port with the bail facing up and some SFP transceivers with the bail facing down.

#### **Warning:**

##### **Risk of equipment damage**

Transceivers are keyed to prevent incorrect insertion. If the transceiver resists pressure, do not force it; turn it over, and reinsert it.

Apply a light pressure to the device until it clicks and locks into position.

4. Remove the dust cover from the optical bore, and insert the fiber optic connector.

## Example

The following figure shows an example installation of a bore plug transceiver with the bail latch facing up. The figure does not represent a specific product.

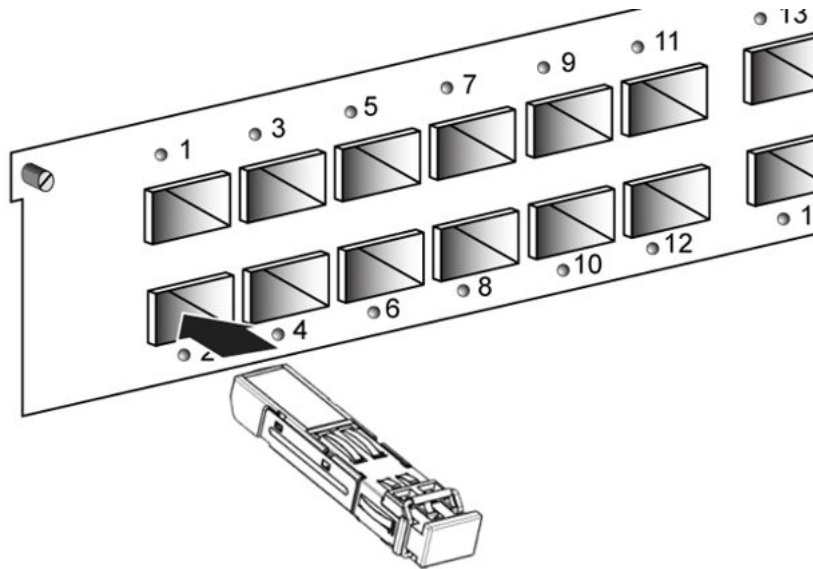

## Job aid

Depending on the transceiver manufacturer, the SFP transceiver can use different types of locking and extractor mechanisms.

The following figure shows the typical mechanism used on SFP transceivers; other locking mechanisms exist although they are not shown here. In the following figure, the SFP transceiver uses the bore plug. Pull the bail to release the device.

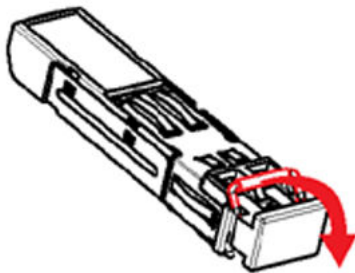

---

## Removing an SFP

Remove an SFP to replace it or to commission it elsewhere.

### Before you begin

- Wear an antistatic wrist strap.

** Danger:****Risk of eye injury by laser**

Fiber optic equipment can emit laser or infrared light that can injure your eyes. Never look into an optical fiber or connector port. Always assume that fiber optic cables connect to a light source.

** Electrostatic alert:**

ESD can damage electronic circuits. Do not touch electronic hardware unless you wear a grounding wrist strap or other static-dissipating device.

**Procedure**

1. Disconnect the network fiber optic cable from the SFP connector.
2. Depending on your SFP model, there are different locking mechanisms to release the SFP transceiver. The following describes the typical mechanism used on SFP transceivers; other locking and extractor mechanisms exist, although they are not described here.
  - Bail latch: Pull the swing-down latch handle to the fully lowered position and hold the handle to extract the module.
3. Slide the SFP out of the module SFP slot.

If the SFP does not slide easily from the module slot, use a gentle side-to-side rocking motion while firmly pulling the SFP from the slot.

4. Affix dust covers over the fiber optic bore and connector.
5. Store the SFP in a safe place until needed.

** Important:**

If you discard the SFP transceiver, dispose of it according to all national laws and regulations.

---

## SFP specifications

This section provides technical specifications for the supported small form factor pluggable (SFP) models. Use this information to aid in proper network design.

The specifications in this section meet or exceed those specified in the applicable IEEE standards, where they exist.

In these specifications, unless otherwise noted, receiver sensitivity is the minimum average input optical power for which the receiver is guaranteed to meet the bit error rate (BER) of  $10^{-12}$ .

---

## SFP labels

The Avaya label on a typical SFP transceiver contains an Avaya serial number, a bar code, a manufacturer code, an interface type, and a part number.

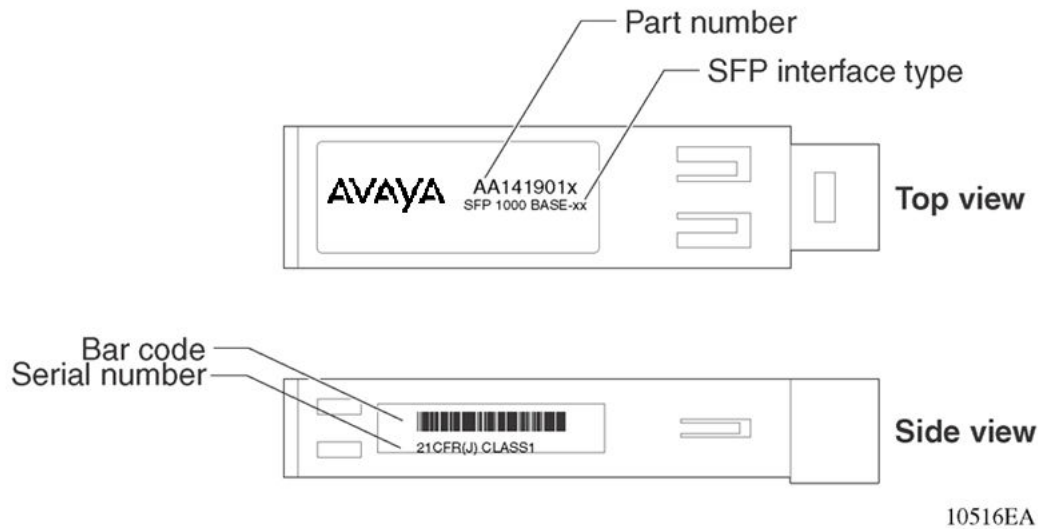

Figure 1: SFP label

## General SFP specifications

The following table describes general SFP specifications.

Table 2: General SFP specifications

Parameter	Description
Dimensions (H x W x D)	8.5 x 13.4 x 56.4 millimeters (0.33 x 0.53 x 2.22 inches), unless otherwise stated.
Operating temperature	-5 to 85 °C for RoHS -E6 models
Storage temperature	-40 to 85 °C
Maximum supply current	300 mA, unless otherwise stated
Maximum power consumption	1.0 W, unless otherwise stated

## Supported SFP transceivers

The following section provides specifications for the supported SFP transceivers.

### 1000BASE-T SFP specifications

The 1000BASE-T SFP provides Gigabit Ethernet connectivity using a single eight-pin RJ-45 connector.

The 1000BASE-T SFP operates at 1 Gigabits per second (Gbps). Only the ERS 5632 can operate at tri-speeds, and program the 1000BASE-T SFP to operate at 1 Gbps, 100 Megabits per second (Mbps) and 10 Mbps speeds.

The part number for this model is AA1419043-E6.

The maximum current requirement of the SFP is 375 milliamperes (mA) at 5 volts (V).

The following table describes the 1000BASE-T SFP specifications.

**Table 3: IEEE 802.3z 1000BASE-T SFP specifications**

Parameter	Specifications
Standards	IEEE 802.3z, IEEE 802.3ab
Connectors	RJ-45
Cabling	CAT5E or better UTP
Distance	Up to 100 m

## 1000BASE-SX DDI SFP specifications

The 1000BASE-SX DDI SFP transceiver has a reach of up to 550 m using 50 µm MMF, and of 275 m using 62.5 µm MMF. This SFP transceiver operates at 850 nm. The part number is AA1419048-E6.

The following table describes standards, connectors, cabling, and distance for the 1000BASE-SX DDI SFP transceivers.

**Table 4: 1000BASE-SX SFP DDI (550 m) specifications**

Parameter	Specifications
Maximum electrical power consumption	1 watt (W)
Connector	Duplex LC
Cabling	MMF
Data rate	1.0 Gbps
Line rate (8B/10B code)	1.25 Gbps
Link optical power budget	7.5 dB
<b>Transmitter characteristics</b>	
Launch power	−9.5 to −4.0 dBm
<b>Receiver characteristics</b>	
Receiver sensitivity	−17 dBm
Maximum receiver power	0 dBm

## 1000BASE-LX DDI SFP specifications

This SFP transceiver provides 1000BASE-LX Gigabit Ethernet connectivity at 1310 nanometers (nm) using single mode or multimode optical fiber. The part number is AA1419049-E6.

**Table 5: 1000BASE-LX DDI SFP specifications**

Parameter	Specifications
Maximum electrical power consumption	1.0 watt (W)
Connectors	Duplex LC
Cabling	<ul style="list-style-type: none"> <li>• 50 micrometer (<math>\mu\text{m}</math>) multimode fiber (MMF)</li> <li>• 62.5 <math>\mu\text{m}</math> multimode fiber</li> <li>• 9 <math>\mu\text{m}</math> single mode fiber (SMF)</li> </ul>
Distance	<ul style="list-style-type: none"> <li>• Up to 550 meters (m) using MMF</li> <li>• Up to 10 kilometers (km) using SMF</li> </ul>
Data rate	1.0 Gbps
Line rate (8B/10B code)	1.25 Gbps
Link optical power budget	9.5 dB
<b>Transmitter characteristics</b>	
Launch power	-9.5 to -3.0 dBm
<b>Receiver characteristics</b>	
Receiver sensitivity	-19.0 dBm
Maximum receiver power	-3.0 dBm

## 1000BASE-BX bidirectional SFP transceivers

The 1000BASE-BX bidirectional DDI SFP transceivers provides Gigabit Ethernet connectivity over a single fiber.

In the following figure, the transmit (Tx) and receive (Rx) paths share the same fiber by using two different wavelengths. One model transmits at 1310 nm and receives at 1490 nm, while the mating model transmits at 1490 nm and receives at 1310 nm. You can only connect a mating pair.

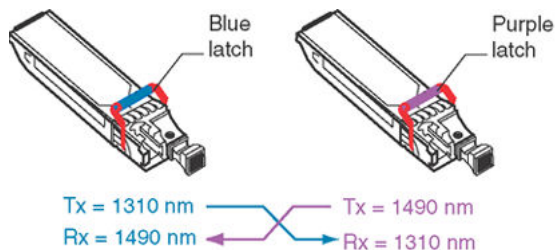

The long wavelength optical transceivers used in these models provide variable distance ranges using single mode fiber optic cabling.

You can use 1000BASE-BX SFP transceivers to double the number of your fiber links. For example, if you install 20 fiber pairs with 20 conventional ports connected, you can use 1000BASE-BX SFP transceivers to expand to 40 ports, using the same fiber.

The following table provides the reach and part numbers for each mating pair.

**Table 6: 1000BASE-BX SFP transceivers**

Reach	1310 nm	1490 nm
10 km	AA1419069-E6	AA1419070-E6

### 1000BASE-BX10 bidirectional DDI SFP specifications

The 1000BASE-BX10 SFP transceivers (part numbers AA1419069-E6 and AA1419070-E6) can attain a reach of up to 10 km.

The following table describes standards, connectors, cabling, and distances for the 1000BASE-BX10 SFP transceiver.

**Table 7: IEEE 802.3ah 1000BASE-BX10 bidirectional SFP specifications**

Parameter	Specification
Connectors	Single-fiber LC
Data rate	1.0 Gbps
Line rate (8B/10B code)	1.25 Gbps
Distance	Up to 10 km
Wavelength	1310 nm and 1490 nm
Link optical power budget	11.0 dB
Maximum transmitter and dispersion power penalty	3.3 dB
<b>Transmitter characteristics</b>	
Maximum launch power	-3.0 dBm
Minimum launch power	-9.0 dBm
<b>Receiver characteristics</b>	
Maximum receiver sensitivity	-19.5 dBm
Maximum input power (maximum average receive power)	-3.0 dBm

### 1000BASE-BX40 bidirectional SFP specifications

The 1000BASE-BX40 SFP transceivers (part numbers AA1419076-E6 and AA1419077-E6) can attain a reach of up to 40 km. The minimum IL is 6 dB.

The following table describes standards, connectors, cabling, and distances for the 1000BASE-BX40 SFP transceiver.

**Table 8: 1000BASE-BX40 bidirectional SFP specifications**

Parameter	Specifications
Connectors	Single-fiber LC
Data rate	1.0 Gbps
Line rate (8B/10B code)	1.25 Gbps



Parameter	Specifications
Distance	Up to 40 km with SMF
Wavelength	1310 nm and 1490 nm
Link optical power budget	20.0 dB
Maximum transmitter and dispersion power penalty	3.3 dB
<b>Transmitter characteristics</b>	
Maximum launch power	3.0 dBm
Minimum launch power	-3.0 dBm
<b>Receiver characteristics</b>	
Maximum receiver sensitivity	-23 dBm
Maximum input power (maximum average receive power)	-3.0 dBm

# Chapter 6: SFP+

This chapter provides installation procedures and specifications for small form factor pluggable plus (SFP+) transceivers.

Use an SFP+ transceiver to connect a device motherboard to a fiber optic or unshielded twisted pair network cable. The SFP+ transceivers described in this section provide Ethernet at 1 gigabit per second (Gbps).

---

## SFP+ transceivers

This section describes how to select and install small form factor pluggable plus (SFP+) transceivers.

Use an SFP+ transceiver to connect a device motherboard to fiber optic or direct attached cables. SFP+ transceivers are similar to SFP transceivers in physical appearance but SFP+ transceivers support 10 gigabit per second (Gbps) connections. You must ensure that your switch supports SFP+ transceivers before installation or use. SFP+ transceivers support 10 Gbps connections, but are not compatible devices.

### Important:

Avaya recommends that you only use Avaya qualified transceivers. If you use other vendor transceivers, Avaya does not support them.

---

## Selecting an SFP+

Use an SFP+ transceiver for 10 Gigabit per second (Gbps) Ethernet connections over optical fiber.

### About this task

Select the appropriate transceiver to provide the required reach. Depending on the product, you can obtain SFP+ transceivers for cable distances of up to 15 meters (m), 400 m, 10 kilometers (km), 40 km, and 70 km. Alternatively, you can use a direct attach cable (10GBASE-CX) to connect ports for cable distances of up to 15 meters.

### Procedure

1. Determine the required reach.

2. Determine wavelength restrictions or requirements.

---

## Installing an SFP+

Install an SFP+ transceiver to provide a 10 Gigabit Ethernet interface between the device and other network devices.

### Before you begin

#### Important:

Do not install an SFP+ transceiver in an SFP slot. The two transceivers look the same but function differently. Ensure the slot is an SFP+ slot.

- Verify that the SFP+ transceiver is the correct model for your network configuration.
- Before you install the fiber, ensure that the connector is clean.

#### Danger:

##### Risk of eye injury by laser

Fiber optic equipment can emit laser or infrared light that can injure your eyes. Never look into an optical fiber or connector port. Always assume that fiber optic cables connect to a light source.

#### Electrostatic alert:

ESD can damage electronic circuits. Do not touch electronic hardware unless you wear a grounding wrist strap or other static-dissipating device.

#### Warning:

##### Risk of equipment damage

Only trained personnel can install this product.

### About this task

Installing an SFP+ transceiver takes approximately 3 minutes.

### Procedure

1. Remove the SFP+ transceiver from its protective packaging.
2. Grasp the SFP+ transceiver between your thumb and forefinger.
3. Insert the device into the port on the module.

Depending on the module type, you must insert some SFP+ transceivers into the port with the bail facing up and some SFP+ transceivers with the bail facing down.

#### Warning:

##### Risk of equipment damage

SFP+ transceivers are keyed to prevent incorrect insertion. If the SFP+ transceiver resists pressure, do not force it; turn it over, and reinsert it.

Apply a light pressure to the SFP+ transceiver until the device clicks and locks into position in the module.

4. Remove the dust cover from the SFP+ optical bores, and insert the fiber optic cable.

**Example**

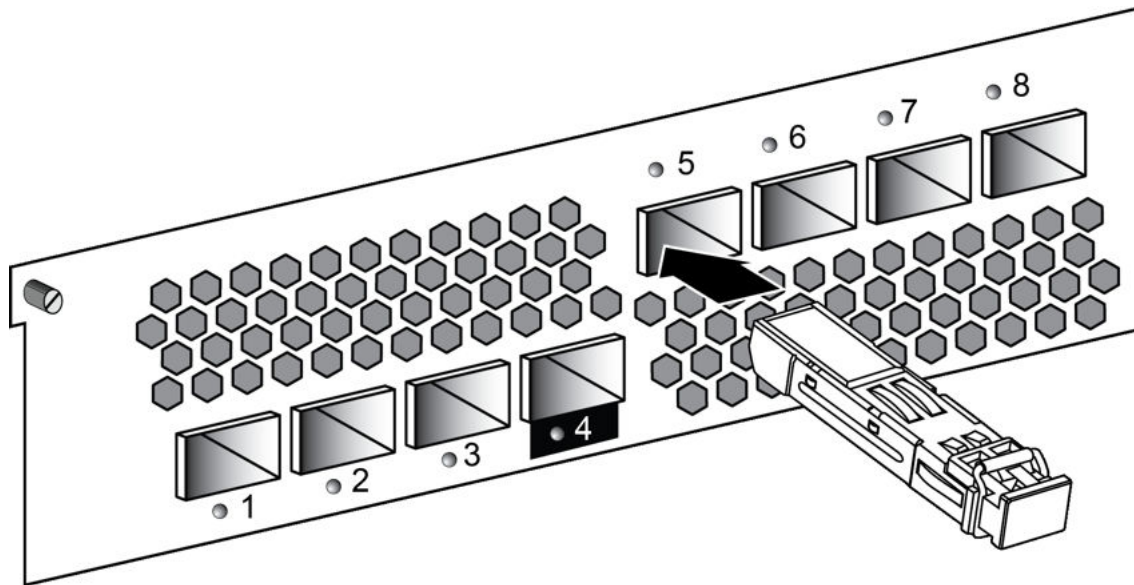

**Job aid**

Depending on the transceiver manufacturer, the SFP+ transceiver uses bail-latch type of locking and extractor mechanism.

The following figure shows typical mechanism used on SFP+ transceivers; other locking and extractor mechanisms exist. SFP+ transceivers are similar to SFP transceivers in physical appearance. In the following figure, the SFP+ transceiver still contains the bore plug. Pull the bail to release the device.

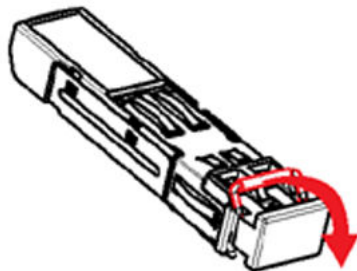

---

## Removing an SFP+

Remove an SFP+ transceiver to replace it or to commission it elsewhere.

### Before you begin

- Wear an antistatic wrist strap.

#### **Danger:**

##### **Risk of eye injury by laser**

Fiber optic equipment can emit laser or infrared light that can injure your eyes. Never look into an optical fiber or connector port. Always assume that fiber optic cables connect to a light source.

#### **Electrostatic alert:**

ESD can damage electronic circuits. Do not touch electronic hardware unless you wear a grounding wrist strap or other static-dissipating device.

### Procedure

1. Disconnect the network fiber optic cable from the SFP+ connector.
2. Pull the swing-down latch handle to the fully lowered position, and hold the handle to extract the module.
3. Slide the SFP+ transceiver out of the module SFP+ slot.

If the SFP+ does not slide easily from the module slot, use a gentle side-to-side rocking motion while firmly pulling the SFP+ transceiver from the slot.

4. Affix dust covers over the fiber optic bore and connector.
5. Store the SFP+ transceiver in a safe place until needed.

#### **Important:**

If you discard the SFP+ transceiver, dispose of it according to all national laws and regulations.

---

## SFP+ specifications

This section provides technical specifications for the supported 10 gigabit SFP+ models. Use these specifications to aid in network design.

The specifications in this section are a subset of the IEEE 802.3ae, 802.3aq, and 802.3ak specifications. For more information, see these standards documents. All Avaya SFP+ transceivers meet or exceed these standards.

**! Important:**

Avaya recommends that you only use Avaya qualified transceivers. If you do choose to use other vendor transceivers, Avaya does not support them.

## SFP+ labels

The typical Avaya SFP+ transceiver has a label on the top and bottom or side of the transceiver. The following figures show example labels. Avaya does use alternate labels, depending on the size of the device and space available for label information. Some devices do not have a CLEI code or label.

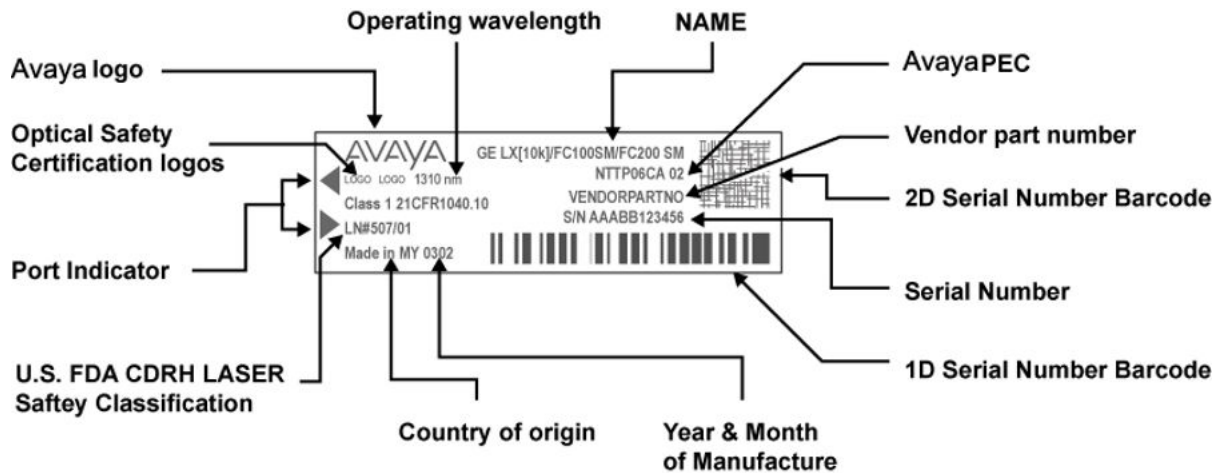

Figure 2: SFP+ top label



Figure 3: SFP+ bottom label

## General SFP+ specifications

The following table describes general SFP+ specifications.

Table 9: General SFP+ specifications

Parameter	Specifications
Dimensions (H x W x D)	8.5 x 13.4 x 56.4 millimeters (0.33 x 0.53 x 2.22 inches), unless otherwise stated.
Connectors	LC ultra physical contact (UPC)

Parameter	Specifications
Storage temperature	–40 to 85 °C
Operating temperature	0 to 70 °C for RoHS -E6 models up to 85 °C for high temperature models

## Supported SFP+ transceivers

The following section provides specifications for the supported SFP+ transceivers.

### 10GBASE-T SFP+ transceiver

The 10GBASE-T SFP+ transceiver provides 10 Gigabit Ethernet connectivity using a single eight pin RJ-45 connector.

The 10GBASE-T SFP+ only operates at 10 Gigabits per second (Gbps) speed. Operation at 10/100/1000 Megabits per second (Mbps) speeds are not supported.

The part number for this model is AA1403043-E6.

The maximum power of the SFP+ transceiver is 2.5 watts (W) at 30 meters (m).

The following table describes the 10GBASE-T SFP+ specifications.

**Table 10: IEEE 802.3z 10GBASE-T SFP specifications**

Parameter	Specifications
Connectors	RJ-45
Cabling	Cat 6a/7 for 10 Gb Ethernet
Distance	up to 30 m (over Cat 6a/7 cable)

### 10GBASE-SR/SW SFP+ specifications

The 10GBASE-SR/SW SFP+ transceivers provides 10 GbE service at 850 nm.

For more information about the 10GBASE-SR/SW SFP+ transceiver, including test and measurement information, see the IEEE 802.3ae standard.

#### **Caution:**

##### **Risk of equipment damage**

To prevent damage to the optical receiver, ensure that at least 1 dB of attenuation exists between the transmit and receive ports.

The following table lists the specifications for the 10GBASE-SR/SW SFP+ transceivers. The part number of this SFP+ transceiver is AA1403015-E6.

**Table 11: IEEE 802.3ae 10GBASE-SR/SW SFP+ transceiver specifications**

Parameter	Specifications
Data rate	10 Gigabits per second (Gbps)
Line rate (64B/66B code)	10.3125 Gbps $\pm$ 100 parts per million (ppm)
Center wavelength range	840 to 860 nanometers (nm), nominal 850 nm
Distance	Using 62.5 $\mu$ m MMF optic cable: <ul style="list-style-type: none"> <li>• 160 MHz-km fiber: 2 to 26 m</li> <li>• 200 MHz-km fiber: 2 to 33 m</li> </ul> Using 50 $\mu$ m MMF optic cable: <ul style="list-style-type: none"> <li>• 400 MHz-km fiber: 2 to 66 m</li> <li>• 500 MHz-km fiber: 2 to 82 m</li> <li>• 2000 MHz-km fiber: 2 to 300 m</li> <li>• 4700 MHz-km fiber (OM4): 2 to 400 m</li> </ul>
Link optical power budget	3.8 dB
Maximum transmitter and dispersion penalty	3.9 dB at 300 m
<b>Transmitter characteristics</b>	
Root-mean-square spectral width	0.05 to 0.40 nm
Launch power	-7.3 to -1.0 dBm
Minimum extinction ratio	3.0 dB
Maximum optical return loss tolerance	-12 dB
<b>Receiver characteristics</b>	
Average receive power for BER $10^{-12}$	-9.9 to -1.0 dBm
Receiver damage threshold	0 dBm
Maximum receiver sensitivity in OMA	-11.1 dBm
Maximum receiver reflectance	-12 dB
Stressed receiver sensitivity in OMA	-7.5 dBm

## 10GBASE-LRM SFP+ specifications

The 10GBASE-LRM SFP+ transceiver provides 10 GbE service at a wavelength of 1310 nm. This SFP+ transceiver supports a reach of up to 220 m on 62.5  $\mu$ m multimode fiber (MMF), as specified in IEEE 802.3-2015 CL68. This SFP+ transceiver can also be used with standard single mode fiber (SMF) to attain a reach of up to 300 m.

The following table lists the transmitter and receiver specifications for the 10GBASE-LRM SFP+ transceiver. The part number of this SFP+ transceiver is AA1403017-E6.

In this table, the OMA, average launch power, and peak power specifications apply at TP2, after accounting for patch cord loss.



**Table 12: 10GBASE-LRM SFP+ transceiver specifications**

Parameter	Specifications
Data rate	10 Gbps
Line rate (64B/66B code)	10.3125 Gbps $\pm$ 100 ppm
Center wavelength range	1260 to 1355 nm; 1310 nm nominal
Distance	Up to 220 m on 62.5 $\mu$ m MMF Up to 300 m on SMF
Link optical power budget	1.7 to 1.9 dB
Maximum transmitter waveform and dispersion penalty (TWDP)	4.7 dB
<b>Transmitter characteristics</b>	
Average launch power	-6.5 to 0.5 dBm
Peak launch power	3 dBm
Root-mean-square spectral width	2.4 to 4 nm
Launch power in OMA	-4.5 to 1.5 dBm
Minimum extinction ratio	3.5 dB
Optical return loss tolerance (minimum)	-20 dB
<b>Receiver characteristics</b>	
Receiver damage threshold	1.5 dBm
Receiver reflectance (maximum)	-12 dB

For more information about the conditions used for the stressed receiver tests, and other information, see the IEEE 802.3–2012 standard.

The following table (from IEEE 802.3–2012) describes the maximum channel insertion loss. The channel insertion loss includes both attenuation and connector loss (1.5 dB); therefore the maximum fiber attenuation is 0.2 to 0.4 dB.

**Table 13: 10GBASE-LRM channel insertion loss and range**

Fiber type (core diameter and OFL bandwidth)	Range	Maximum channel insertion loss
62.5 $\mu$ m (FDDI grade) • 160 MHz-km at 850 nm • 500 MHz-km at 1300 nm	Up to 220 m	1.9 dB
62.5 $\mu$ m (ISO/IEC OM1) • 200 MHz-km at 850 nm • 500 MHz-km at 1300 nm	Up to 220 m	1.9 dB
50 $\mu$ m (ISO/IEC OM2) • 500 MHz-km at 850 nm	Up to 220 m	1.9 dB

Fiber type (core diameter and OFL bandwidth)	Range	Maximum channel insertion loss
• 500 MHz-km at 1300 nm		
50 µm • 400 MHz-km at 850 nm • 400 MHz-km at 1300 nm	Up to 100 m	1.7 dB
50 µm (ISO/IEC OM3) • 1500 MHz-km at 850 nm (includes laser launch bandwidth) • 500 MHz-km at 1300 nm (includes laser launch bandwidth)	Up to 220 m	1.9 dB

The following abbreviations are used in the preceding tables:

- FDDI – Fiber Distributed Data Interface
- ISO – International Standards Organization
- IEC – International Electrotechnical Commission
- OFL – Over Filled Launch

## 10GBASE-LR/LW SFP+ specifications

The 10GBASE-LR/LW SFP+ transceiver provides 10 GbE or OC-192 service at a nominal wavelength of 1310 nm. This SFP+ transceiver can attain link lengths of up to 10 km.

For more information about the 10GBASE-LR/LW SFP+ transceiver, including test and measurement information, see the IEEE 802.3ae standard.

The following table lists the transmitter and receiver specifications for the 10GBASE-LR/LW SFP+ transceiver. The part number of this SFP+ transceiver is AA1403011-E6.

**Table 14: IEEE 802.3ae 10GBASE-LR/LW SFP+ transceiver specifications**

Parameter	Specifications
Center wavelength range	1260 to 1355 nm; 1310 nm nominal
Distance	Up to 10 km
Link optical power budget	9.4 dB
Maximum transmitter and dispersion penalty	3.2 dB at 10 km
<b>Transmitter characteristics</b>	
Line rate (nominal)	10GBASE-LR 10.3125 Gbps ±100 ppm (10 GbE)
Average launch power	−8.2 to 0.5 dBm
Minimum launch power in OMA minus transmission and dispersion penalty (TDP)	−6.2 dBm
Minimum optical modulation amplitude	−5.2 dBm
Minimum extinction ratio	3.5 dB

Parameter	Specifications
Maximum optical return loss tolerance	-12 dB
Maximum transmitter reflectance	-12 dB
<b>Receiver characteristics</b>	
Line rate (nominal)	10GBASE-LR 10.3125 Gbps $\pm$ 100 ppm (10 GbE)
Average receive power for BER $10^{-12}$	-14.4 dBm to 0.5 dBm
Receiver damage threshold	1.5 dBm
Maximum receiver sensitivity in OMA	-12.6 dBm
Maximum receiver reflectance	-12 dB
Stressed receiver sensitivity in OMA	-10.3 dBm

Examples of an OFF transmitter are as follows: no power supplied to the PDM, laser shutdown for safety conditions, activation of a PMD\_global\_transmit\_disable or other optional transmitter shutdown condition.

## 10GBASE-ER/EW SFP+ specifications

The 10GBASE-ER/EW SFP+ transceiver provides a reach of up to 40 km at a wavelength of 1550 nm.

For more information about the 10GBASE-ER/EW SFP+ transceiver, including test and measurement information, see the IEEE 802.3ae standard.

The following table lists the transmitter and receiver specifications for the 10GBASE-ER/EW SFP+ transceiver. The part number of this SFP+ transceiver is AA1403013-E6.

**Table 15: IEEE 802.3ae 10GBASE-ER/EW SFP+ transceiver specifications**

Parameter	Specifications
Line rate (nominal)	10GBASE-ER/EW 10.3125 Gb/s $\pm$ 100 ppm (10 GbE)
Center wavelength range	1530 to 1565 nm; nominal 1550 nm
Distance	Up to 40 km
Link optical power budget	15 dB
Transmitter and dispersion power penalty	3.0 dB at 40 km
<b>Transmitter characteristics</b>	
Launch power	-4.7 to 4.0 dBm
Minimum side mode suppression ratio	30 dB
Minimum launch power in OMA minus transmission and dispersion penalty (TDP)	-2.1 dBm
Minimum optical modulation amplitude	-1.7 dBm
Maximum average launch power of OFF transmitter	-30 dBm
Minimum extinction ratio	3.0 dB
Maximum $RIN_{12}$ OMA	-128 dB/Hz

Parameter	Specifications
Maximum optical return loss tolerance	-21 dB
<b>Receiver characteristics</b>	
Average receive power for BER $10^{-12}$	- 15.8 dBm to -1.0 dBm
Maximum receive power for damage	4.0 dBm
Maximum receiver sensitivity in OMA	-14.1 dBm
Maximum receiver reflectance	-26 dB
Stressed receiver sensitivity in OMA	-11.3 dBm
Receive electrical 3 dB upper cutoff frequency (maximum)	12.3 GHz

The following list shows examples of an OFF transmitter:

- No power supplied to the PDM.
- Laser shutdown for safety conditions.
- Activation of `PMD_global_transmit_disable` or other optional transmitter shutdown condition.

## 10GBASE-CX specifications

The 10GBASE-CX is a 2-pair twinaxial copper cable that plugs into the SFP+ socket and connects two 10-Gigabit ports. The reach for this cable is up to 15 m with a bit error rate (BER) better than  $10^{-12}$ .

The 10GBASE-CX is a lower cost alternative to the optical SFP+ devices.

For more information about the 10GBASE-CX, including test and measurement information and more specifications, see the IEEE 802.3-2012 standard. The following table identifies the part numbers for specific cable lengths.

**Table 16: 10GBASE-CX cables**

Cable length	Part number
3 meter	AA1403019-E6
5 meter	AA1403020-E6
10 meter	AA1403018-E6

## 10GBASE-ZR/ZW SFP+ specifications

The following table lists the transmit and receive specifications for the 10GBASE-ZR/ZW SFP+ transceiver. The part number of this SFP+ transceiver is AA1403016-E6.

### **Warning:**

Risk of BER increase

For proper SFP+ transceiver operation, ensure that at least 11 dB of attenuation is present between the transmit and receive ports.

The reach for this SFP+ transceiver is up to 70 km\* at a wavelength of 1550 nm.

**Table 17: 10GBASE-ZR/ZW SFP+ specifications**

Parameter	Specifications
Line rate (nominal)	10GBASE-ZR 10.3125 Gbps $\pm$ 100 ppm (10 GbE)
Distance	Up to 70 km *
Link optical power budget	24 dB
Dispersion power penalty	3.0 dB at 70 km (G.652 fiber)
Minimum attenuation between transmit and receive ports	11 dB
<b>Transmitter characteristics</b>	
Center wavelength range	1530 to 1565 nm, nominal 1550 nm
Average launch power	0 to 4.0 dBm
Optical modulation amplitude (minimum)	-1.7 dBm
Extinction ratio (ER) (minimum)	8.2 dB
Maximum transmitter reflectance	-12 dB
<b>Receiver characteristics</b>	
Wavelength range	1280 to 1575 nm. Sensitivity specified for 1530 to 1565 nm.
Maximum receiver sensitivity (average power)	-24 dBm
Maximum receiver (average) power, BER $10^{-12}$	-7.0 dBm
Receiver damage threshold (average power)	+5.0 dBm
Receiver reflectance (maximum)	-27 dB

\* Achievable link distance is primarily dependent on cable plant insertion loss. 70 km is not possible in some situations.

## 10GBASE CWDM DDI SFP+ (40 km) specifications

The following table lists the part numbers of the 10GBASE CWDM DDI SFP+ (40 km) with corresponding wavelengths.

**Table 18: Part number and center wavelength assignment**

Part number	Center wavelength assignment	Reach	Insertion loss Tx to Rx
AA1403153-E6	1471 nm	up to 40 km	5 dB
AA1403154-E6	1491 nm	up to 40 km	5 dB
AA1403155-E6	1511 nm	up to 40 km	5 dB
AA1403156-E6	1531 nm	up to 40 km	5 dB
AA1403157-E6	1551 nm	up to 40 km	5 dB

Part number	Center wavelength assignment	Reach	Insertion loss Tx to Rx
AA1403158-E6	1571 nm	up to 40 km	5 dB
AA1403159-E6	1591 nm	up to 40 km	5 dB
AA1403160-E6	1611 nm	up to 40 km	5 dB

The following table lists the transmitter and receiver specifications for the 10GBASE CWDM DDI SFP+ (40 km).

**Table 19: 10GBASE-ER CWDM DDI SFP+ specifications**

Parameter	Specifications
<b>Transmitter characteristics:</b>	
Optical Data Rate (nominal)	9.95 Gbps to 10.313 Gbps
Center wavelength	Nominal –6.5 nm to nominal +6.5 nm
Spectral width (RMS at –20 dB)	1 nm
Average launched power	–0.2 dBm to 4 dBm
Extinction ratio (minimum)	8.2 dB
Tx power, OMA (minimum)	+1.5 dBm
Tx power, OMA-TDP (minimum)	–0.2 dBm
TDP at 800 ps dispersion (maximum)	2.8 dB
<b>Receiver characteristics:</b>	
Wavelength (requirement)	1450 nm to 1620 nm
Receiver sensitivity (unstressed), OMA	–14.1 dBm, P_OMA
IEEE 10GBASE-ER Stressed Rx Sensitivity	–11.3 dBm, P_OMA
Receiver overload	–1 dBm, P_avg
Receiver reflectance	–26 dB
Receiver damage threshold	+4 dBm

## 10GBASE CWDM DDI SFP+ (70 km) specifications

The following table lists the part numbers for the 10GBASE CWDM DDI SFP+ (70 km) transceivers with corresponding wavelengths.

The reach for this SFP+ transceiver is up to 70 km\* at a wavelength of 1551 nm.

**Table 20: Part number and center wavelength assignment**

Part number	Center wavelength assignment	Reach	Minimum insertion loss Tx and Rx
AA1403161-E6	1471 nm	70 km	10 dB
AA1403162-E6	1491 nm	70 km	10 dB

Part number	Center wavelength assignment	Reach	Minimum insertion loss Tx and Rx
AA1403163-E6	1511 nm	70 km	10 dB
AA1403164-E6	1531 nm	70 km	10 dB
AA1403165-E6	1551 nm	70 km	10 dB
AA1403166-E6	1571 nm	70 km	10 dB
AA1403167-E6	1591 nm	70 km	10 dB
AA1403168-E6	1611 nm	70 km	10 dB

\* Achievable link distance is primarily dependent on cable plant insertion loss. 70 km is not possible in some situations.

The following table lists the transmitter and receiver specifications for the 10GBASE CWDM DDI SFP+ (70 km) transceiver.

**Table 21: 10GBASE-ZR CWDM DDI SFP+ specifications**

Parameter			Specifications
<b>Transmitter characteristics</b>			
Optical Data Rate (nominal)			9.95 Gbps to 10.313 Gbps
Center wavelength			Nominal $-6.5$ nm to nominal $+6.5$ nm
Spectral width (RMS at $-20$ dB)			1 nm
RIN OMA			$-128$ dB/Hz
Extinction ratio (minimum)			8.2 dB
Tx output:	Min	Max	Units
P_avg	$-1$	4	dBm
OMA	$+0.7$	—	dBm
OMA-TDP	$-2.3$	—	dBm
TDP at 1400 ps dispersion			3 dB
Optical return loss tolerance			21 dB
<b>Receiver characteristics</b>			
Wavelength range			1460 nm to 1620 nm
Rx sensitivity:	Min	Max	Units
back-to-back	—	$-23$	dBm
with 70 km fiber	—	$-21$	dBm
with 70 km fiber, OMA	—	$-19.3$	dBm
Receiver overload			$-7$ dBm, P_avg
Receiver reflectance			$-27$ dB
Receiver damage threshold			$+5$ dBm, P_avg

## 10GBASE-BX SFP+ specifications

The 10GBASE-BX SFP+ provides 10 Gigabit Ethernet (GbE) service with single mode bidirectional transceivers. One transceiver transmits at 1270 nm and receives at 1330 nm and the mating transceiver transmits at 1330 nm and receives at 1270 nm.

**\* Note:**

Transceivers AA1403169-E6 and AA1403170-E6 must be used only as a pair.

The following table provides the wavelength and distance details for the transceiver pair:

AA1403169-E6	1270 nm Tx	1330 nm Rx	up to 10 km	Paired with AA1403170-E6
AA1403170-E6	1330 nm Tx	1270 nm Rx	up to 10 km	Paired with AA1403169-E6

The following table lists the specifications for the 10GBASE-BX SFP+ transceivers.

Parameter	Specifications
Connector	Single-fiber LC
Data rate	10 Gbps
Line rate	10.3125 Gbps
Distance	Up to 10 km
Single power supply	3.3 V
Maximum transmitter and dispersion penalty	3.2 dBm
Operating case temperature range	-40 to +85 °C
<b>Transmitter characteristics</b>	
Wavelength	1270 +/- 10 nm or 1330 +/- 10 nm
Launch power	-8.2 to +0.5 dBm
Average launch power of OFF transmitter $p_{OFF}$	-30 dBm
Minimum extinction ratio	3.5 dB
Optical Modulation Amplitude $p_{OMA}$	-5.2 dBm
OMA-TDP, min	-6.2 dBm
<b>Receiver characteristics</b>	
Wavelength	1330 +/- 10 nm or 1270 +/- 10 nm
Average receive power	-14.4 to +0.5 dBm
Maximum receiver sensitivity in OMA	-12.6 dBm
Maximum receiver reflectance	-12 dB
Stressed receiver sensitivity in OMA	-10.3 dBm



# Chapter 7: End of sale transceivers and cables

## Related links

[Locating end of sale notices](#) on page 41

[End of sale SFP transceivers](#) on page 41

[End of sale SFP+ transceivers](#) on page 42

---

## Locating end of sale notices

Use the following procedure to locate the most up-to-date information on end of sale notices and replacement recommendations for transceivers and optical components.

### Procedure

1. Go to the Avaya Support website at <http://support.avaya.com/>.
2. Select **Support by Product > Documents**.
3. Enter the product name, and a release.
4. Select Product Lifecycle Notices.
5. Click **Enter**.
6. Select the End of Sale notice to view the information.

## Related links

[End of sale transceivers and cables](#) on page 41

---

## End of sale SFP transceivers

The transceivers in the following table have reached end of sale (EOS).

**Table 22: Discontinued SFP transceivers**

Model	Part number	Date EOS	Replacement
1000BASE-SX	AA1419013-E5	December 31, 2014	AA1419048-E6
1000BASE-SX MT-RJ	AA1419014-E5		—
1000BASE-LX	AA1419015-E5	December 31, 2014	AA1419049-E6
1000BASE-XD CWDM	AA1419025-E5 to AA1419032-E5	June 30, 2012	
1000BASE-ZX CWDM	AA1419033-E5 to AA1419040-E5	June 30, 2012	—
1000BASE-XD DDI 1330 nm	AA1419050-E6	September 30, 2014	—
1000BASE-XD DDI 1550 nm	AA1419051-E6	September 30, 2014	AA1419057-E6
1000BASE-ZX DDI 1550 nm	AA1419052-E6	September 30, 2014	AA1419065-E6
1000BASE- XD DDI 40 km	AA1419053-E6 to AA1419060-E6	December 14, 2016	—
1000BASE-ZX DDI CWDM 70 km	AA1419061-E6 to AA1419068-E6   <b>Important:</b> AA1419065-E6 remains available for purchase.	June 13, 2016	AA1419065-E6
1000BASE-EX DDI	AA1419071-E6	June 2016	—
T1 Ethernet over TDM mini-GBIC	AA1419075-E6	June 2016	—
1000BASE-BX40	AA1419076-E6 and AA1419077-E6	June 2016	—

**Related links**

[End of sale transceivers and cables](#) on page 41

---

## End of sale SFP+ transceivers

The transceivers in the following table have been identified as end of sale (EOS). For more information about EOS transceivers and recommended replacements for your product or to determine existing availability for these transceivers, see [Locating end of sale notices](#) on page 41.

**Related links**

[End of sale transceivers and cables](#) on page 41

# Chapter 8: Translation of safety messages

---

## Class A electromagnetic interference warning statement

 **Warning:**

**Risk of electromagnetic interference**

This device is a Class A product. Operation of this equipment in a residential area is likely to cause harmful interference, in which case users are required to take appropriate measures necessary to correct the interference at their own expense.

 **Warning:**

**AVERTISSEMENT**

Le périphérique est un produit de Classe A. Le fonctionnement de cet équipement dans une zone résidentielle risque de causer des interférences nuisibles, auquel cas l'utilisateur devra y remédier à ses propres frais.

 **Warning:**

**WARNUNG**

Dies ist ein Gerät der Klasse A. Bei Einsatz des Geräts in Wohngebieten kann es Störungen des Radio- und Fernsehempfangs verursachen. In diesem Fall muss der Benutzer alle notwendigen Maßnahmen ergreifen, die möglicherweise nötig sind, um die Störungen auf eigene Rechnung zu beheben.

 **Warning:**

**ADVERTENCIA**

Este es un producto clase A. El uso de este equipo en áreas residenciales puede causar interferencias nocivas, en cuyo caso, se requerirá que los usuarios tomen cualquier medida necesaria para corregir la interferencia por cuenta propia.

 **Warning:**

**AVISO**

Este dispositivo é um produto Classe A. Operar este equipamento em uma área residencial provavelmente causará interferência prejudicial; neste caso, espera-se que os usuários tomem as medidas necessárias para corrigir a interferência por sua própria conta.

 **Warning:**

**AVVISO**

Questo dispositivo è un prodotto di Classe A. Il funzionamento di questo apparecchio in aree residenziali potrebbe causare interferenze dannose, nel cui caso agli utenti verrà richiesto di adottare tutte le misure necessarie per porre rimedio alle interferenze a proprie spese.

---

## Electrostatic discharge warning statement

 **Electrostatic alert:**

ESD can damage electronic circuits. Do not touch electronic hardware unless you wear a grounding wrist strap or other static-dissipating device.

 **Electrostatic alert:**

**ELEKTROSTATIKWARNUNG**

Elektronische Schaltkreise können durch elektrostatische Entladung beschädigt werden. Berühren Sie elektronische Hardware nur, wenn Sie ein Erdungsarmband oder ein anderes Statik ableitendes Medium tragen.

 **Electrostatic alert:**

**ALERTA DE ELECTROESTÁTICA**

Una descarga electroestática puede dañar los circuitos electrónicos. No toque el hardware electrónico a no ser que utilice una muñequera antiestática u otro dispositivo disipador de estática.

 **Electrostatic alert:**

**ALERTA CONCERNANT LES DÉCHARGES ÉLECTROSTATIQUES**

Une décharge électrostatique (DES) peut endommager les circuits électroniques. Ne touchez pas le matériel électronique, à moins de mettre à votre poignet une bande de mise à la masse ou autre dispositif dissipant l'électricité statique.

 **Electrostatic alert:**

**ALERTA DE ELETROSTÁTICA**

ESD pode danificar circuitos eletrônicos. Não toque em equipamentos eletrônicos a menos que esteja utilizando pulseira de aterramento ou outro dispositivo para dissipação de energia estática.

 **Electrostatic alert:**

**AVVISO ELETTROSTATICO**

Le scariche elettrostatiche (ESD) possono danneggiare i circuiti elettronici. Non toccare i componenti elettronici senza aver prima indossato un braccialetto antistatico o un altro dispositivo in grado di dissipare l'energia statica.

---

## Laser eye safety danger statement

 **Danger:**

**Risk of eye injury by laser**

Fiber optic equipment can emit laser or infrared light that can injure your eyes. Never look into an optical fiber or connector port. Always assume that fiber optic cables are connected to a light source.

 **Danger:**

**DANGER**

Risques de blessure oculaire par lumière laser

L'équipement de fibres optiques peut émettre une lumière laser ou infrarouge nuisible à vos yeux. Ne regardez jamais en direction de fibres optiques ou d'un port connecteur. Supposez toujours que les câbles de fibres optiques sont connectés à une source de lumière.

 **Danger:**

**GEFAHR**

Risiko einer Augenverletzung durch Laser

Risiko einer Augenverletzung durch Laser Glasfasergeräte können Laserstrahlen oder ultraviolettes Licht aussenden, das Ihre Augen verletzen kann. Schauen Sie nie direkt in einen Glasfaserleiter oder Verbindungsanschluss. Gehen Sie immer davon aus, dass Glasfaserkabel mit einer Lichtquelle verbunden sind.

 **Danger:**

**PELIGRO**

Riesgo de lesión en los ojos por láser

El equipo de fibra óptica puede emitir una luz láser o infrarroja que dañe sus ojos. Nunca mire un puerto de fibra óptica o conector. Siempre asuma que los cables de fibra óptica están conectados a una fuente de luz.

 **Danger:**

**PERIGO**

O laser pode causar ferimentos no olho

O equipamento de fibra ótica pode emitir laser ou luz infravermelha que pode causar danos a sua vista. Nunca olhe para dentro da fibra ótica ou da porta do conector. Tenha sempre em mente que os cabos de fibra ótica estão ligados a uma fonte de luz.

 **Danger:**

**PERICOLO**

Rischio di ustioni agli occhi dovute al laser

Le apparecchiature con fibre ottiche possono emettere raggi laser o infrarossi in grado di provocare ferite agli occhi. Non guardare mai all'interno di una porta di connessione o una fibra ottica. Tenere sempre presente che i cavi a fibra ottica sono collegati a una sorgente luminosa.

---

## Laser eye safety connector inspection danger statement

 **Danger:**

**Risk of eye injury**

When you inspect a connector, ensure that light sources are off. The light source used in fiber optic cables can damage your eyes.

 **Danger:**

**DANGER**

Risques de blessure oculaire

Assurez-vous que toutes les sources de lumière ont été désactivées avant de procéder au contrôle d'un connecteur. La source de lumière utilisée dans les câbles de fibres optiques risque de provoquer des lésions oculaires.

 **Danger:**

**GEFAHR**

Verletzungsrisiko der Augen

Achten Sie bei der Kontrolle der Anschlüsse darauf, dass die Lichtquellen abgeschaltet sind. Die für die Glasfaserkabel verwendeten Lichtquellen können Augenschäden hervorrufen.

 **Danger:**

**PELIGRO**

Riesgo de lesiones oculares

Cuando inspeccione un conector, controle que las fuentes de luz estén apagadas. La fuente de luz que utilizan los cables de fibra óptica puede ocasionar daños en la vista.

 **Danger:****PERIGO**

Risco de ferimento nos olhos

Ao inspecionar um conector, verifique se as fontes luminosas estão desligadas. A fonte luminosa usada nos cabos de fibra ótica pode causar danos a seus olhos.

 **Danger:****PERICOLO**

Rischio di lesioni agli occhi

Quando si esamina un connettore, assicurarsi che le sorgenti di luce siano spente. La sorgente di luce utilizzata nei cavi a fibre ottiche potrebbero danneggiare gli occhi.

---

## Connector cleaning safety danger statement

 **Danger:****Risk of eye injury**

When you inspect a connector, ensure that light sources are off. The light source used in fiber optic cables can damage your eyes. To avoid getting debris in your eyes, wear safety glasses when you work with the canned air duster. To avoid eye irritation on contact, wear safety glasses when you work with isopropyl alcohol.

 **Danger:****DANGER**

Risques de blessure oculaire

Assurez-vous que toutes les sources de lumière ont été désactivées avant de procéder au contrôle d'un connecteur. La source de lumière utilisée dans les câbles de fibres optiques risque de provoquer des lésions oculaires. Pour éviter tout risque de projection vers les yeux, portez des lunettes de protection lorsque vous utilisez la bombe dépoussiérante à air comprimé. Pour éviter tout risque d'irritation oculaire, portez des lunettes de protection lorsque vous utilisez de l'alcool à 90°.

 **Danger:****GEFAHR**

Verletzungsrisiko der Augen

Achten Sie bei der Kontrolle der Anschlüsse darauf, dass die Lichtquellen abgeschaltet sind. Die für die Glasfaserkabel verwendeten Lichtquellen können Augenschäden hervorrufen. Zum Schutz vor Schmutzteilchen tragen Sie eine Schutzbrille, wenn Sie mit einem Pressluft-Spray

arbeiten. Zum Schutz vor Augenirritationen tragen Sie eine Schutzbrille, wenn Sie mit Isopropanol arbeiten.

 **Danger:**

**PELIGRO**

Riesgo de lesiones

Cuando inspeccione un conector, controle que las fuentes de luz estén apagadas. La fuente de luz que utilizan los cables de fibra óptica puede ocasionar daños en la vista. Cuando trabaje con el pulverizador de aire envasado, utilice gafas de seguridad para evitar el ingreso de residuos en los ojos. Utilice gafas de seguridad cuando trabaje con alcohol isopropilo para evitar irritación en los ojos.

 **Danger:**

**PERIGO**

Risco de ferimento nos olhos

Ao inspecionar um conector, verifique se as fontes luminosas estão desligadas. A fonte luminosa usada nos cabos de fibra ótica pode causar danos a seus olhos. Para evitar que seus olhos sejam atingidos por resíduos, use óculos de segurança ao trabalhar com lata de ar comprimido. Para evitar irritação dos olhos, use óculos de segurança ao trabalhar com álcool isopropílico.

 **Danger:**

**PERICOLO**

Rischio di lesioni agli occhi

Quando si esamina un connettore, assicurarsi che le sorgenti di luce siano spente. La sorgente di luce utilizzata nei cavi a fibre ottiche potrebbero danneggiare gli occhi. Per evitare l'accidentale introduzione di detriti negli occhi, indossare gli occhiali di sicurezza quando si lavora con un'impolveratrice ad aria compressa. Per evitare irritazioni oculari da contatto, indossare gli occhiali di sicurezza quando si lavora con alcool isopropilico.

---

## Optical fiber damage warning statement

 **Warning:**

**Risk of equipment damage**

Do not crush fiber optic cable. If fiber optic cable is in the same tray or duct with large, heavy electrical cables, the weight of the electrical cable can damage the fiber optic cable.



 **Warning:**

**AVERTISSEMENT**

Risques d'endommagement de l'équipement

N'exercez pas de pression sur les câbles de fibres optiques. Ne placez pas de câbles de fibres optiques dans la même caisse ou dans le même fourreau que des câbles électriques lourds car leur poids risquerait de les endommager.

 **Warning:**

**WARNUNG**

Risiko von Geräteschäden

Das Glasfaserkabel darf nicht zerdrückt werden. Wenn sich ein Glasfaserkabel zusammen mit großen und schweren Elektrokabeln im gleichen Kabelkanal oder in der gleichen Führung befindet, kann es durch das Gewicht der Elektrokabel beschädigt werden.

 **Warning:**

**ADVERTENCIA**

Riesgo de daños en los equipos

Evite aplastar los cables de fibra óptica. Si el cable de fibra óptica se encuentra en la misma bandeja o conducto que otros cables eléctricos grandes y pesados, puede dañarse.

 **Warning:**

**AVISO**

Risco de danos ao equipamento

Não amasse o cabo de fibra ótica. Se o cabo de fibra ótica estiver na mesma bandeja ou duto com cabos elétricos longos e pesados, ele pode ser danificado pelo peso do cabo elétrico.

 **Warning:**

**Avvertenza**

Rischio di danno all'apparecchio

Non schiacciare o piegare il cavo a fibre ottiche. Se il cavo a fibre ottiche è posizionato in un vassoio o condotto con cavi elettrici pesanti e di grosse dimensioni, esso potrebbe essere danneggiato dal peso dei cavi elettrici.

---

## Optical fiber connector damage warning statement

 **Warning:**

**Risk of equipment damage**

To prevent further contamination, clean fiber optic equipment only when you see evidence of contamination.

To prevent contamination, cover the optical ports of all active devices with a dust cap or optical connector.

To avoid the transfer of oil or other contaminants from your fingers to the end face of the ferrule, handle connectors with care.

 **Warning:**

**AVERTISSEMENT**

Risques d'endommagement de l'équipement

Pour éviter tout risque de nouvelle contamination, nettoyez uniquement le matériel en fibre optique lorsque les preuves de contamination sont avérées.

Pour éviter tout risque de contamination, assurez-vous que tous les ports optiques des périphériques sous tension sont protégés par un capuchon anti-poussière ou par un connecteur optique.

Manipulez les connecteurs avec précaution afin d'éviter toute application d'huile provenant de vos doigts ou d'autres contaminants sur l'extrémité de la ferrule.

 **Warning:**

**WARNUNG**

Risiko von Geräteschäden

Zur Vermeidung weiterer Verunreinigungen reinigen Sie die Glasfiber-Ausrüstung nur dann, wenn sie offensichtlich kontaminiert ist.

Zur Vermeidung von Verunreinigungen schützen Sie die optischen Ports aller aktiven Geräte mit einer Staubkappe oder einem optischen Steckverbinder.

Zur Vermeidung von Verunreinigungen des hinteren Muffenteils durch Öl von den Fingern oder durch andere Kontaminationsstoffe behandeln Sie die Anschlüsse vorsichtig.

 **Warning:**

**ADVERTENCIA**

Riesgo de daños en los equipos

Limpie los equipos de fibra óptica únicamente cuando existan rastros de contaminación para evitar diseminarla aun más.

Para evitar la contaminación, controle que los puertos ópticos de todos los dispositivos activos estén cubiertos con una tapa protectora o un conector óptico.

Maneje los conectores con cuidado para no contaminar la superficie de los casquillos con la grasa de los dedos ni otros contaminantes.

 **Warning:****AVISO**

Risco de danos ao equipamento

Para evitar contaminação futura, limpe o equipamento ótico apenas quando houver evidência de contaminação.

Para evitar a contaminação, verifique se as portas óticas de todos os dispositivos ativos estão cobertas com uma proteção contra pó ou conector ótico.

Para evitar a transferência de óleo ou outro agente contaminador de seus dedos para a extremidade final da ponteira, manuseie os conectores com cuidado.

 **Warning:****Avvertenza**

Rischio di danno all'apparecchio

Per evitare ulteriori contaminazioni, pulire l'apparecchio a fibre ottiche solo in presenza di evidente contaminazione.

Per evitare contaminazioni, assicurarsi che le porte ottiche di tutti i dispositivi attivi siano coperte da un tappo antipolvere o da un connettore ottico.

Per evitare il trasferimento di olio o di altri agenti contaminanti dalle dita alla parte finale della ghiera, maneggiare con cura i connettori.

---

## SFP damage warning statement

 **Warning:****Risk of equipment damage**

SFPs are keyed to prevent incorrect insertion. If the SFP resists pressure, do not force it; turn it over, and reinsert it.

 **Warning:****AVERTISSEMENT**

Risques d'endommagement de l'équipement

Afin d'éviter tout risque d'insertion incorrecte, les modules SFP sont verrouillés. Si vous ne parvenez pas à insérer un module SFP, ne forcez pas. Retournez-le et renouvelez l'opération.

 **Warning:****WARNUNG**

Risiko von Geräteschäden

Die SFPs sind so konstruiert, dass ein falsches Einsetzen verhindert wird. Lässt sich ein SFP auch auf Druck hin nicht einsetzen, versuchen Sie nicht, es gewaltsam einzusetzen, sondern drehen Sie es um, und setzen Sie es erneut ein.

 **Warning:**

**ADVERTENCIA**

Riesgo de daños en los equipos

Los módulos SFP cuentan con cuñas que no permiten insertarlos de forma incorrecta. Si el módulo SFP opone resistencia a la presión, no lo fuerce; gírelo e insértelo nuevamente.

 **Warning:**

**AVISO**

Risco de danos ao equipamento

Os SFPs são chaveados para evitar inserção indevida. Se o SFP resistir à pressão, não o force; inverta e recoloque-o.

 **Warning:**

**Avvertenza**

Rischio di danni all'apparecchio

Gli SFP dispongono di chiavi in modo da evitarne l'inserimento errato. Se l'SFP resiste alla pressione, non forzarlo ma capovolgerlo e reinserirlo.

# Chapter 9: Resources

---

## Support

Go to the Avaya Support website at <http://support.avaya.com> for the most up-to-date documentation, product notices, and knowledge articles. You can also search for release notes, downloads, and resolutions to issues. Use the online service request system to create a service request. Chat with live agents to get answers to questions, or request an agent to connect you to a support team if an issue requires additional expertise.

---

## Documentation

For a list of the documentation for this product and more information about documents on how to configure other switch features, see *Documentation Reference for Avaya Ethernet Routing Switch 4900 and 5900 Series, NN47211-103*.

For more information on new features of the switch and important information about the latest release, see *Release Notes for Avaya Ethernet Routing Switch 4900 and 5900 Series, NN47211-400*.

For more information about how to configure security, see *Configuring Security on Avaya Ethernet Routing Switch 4900 and 5900 Series, NN47211-505*.

For the current documentation, see the Avaya Support web site: [www.avaya.com/support](http://www.avaya.com/support).

---

## Training

Ongoing product training is available. For more information or to register, see <http://avaya-learning.com/>.

Enter the course code in the **Search** field and click **Go** to search for the course.

Course code	Course title
8D00020E	Stackable ERS and VSP Products Virtual Campus Offering

---

## Viewing Avaya Mentor videos

Avaya Mentor videos provide technical content on how to install, configure, and troubleshoot Avaya products.

### About this task

Videos are available on the Avaya Support website, listed under the video document type, and on the Avaya-run channel on YouTube.

### Procedure

- To find videos on the Avaya Support website, go to <http://support.avaya.com> and perform one of the following actions:
  - In **Search**, type `Avaya Mentor Videos` to see a list of the available videos.
  - In **Search**, type the product name. On the Search Results page, select **Video** in the **Content Type** column on the left.
- To find the Avaya Mentor videos on YouTube, go to [www.youtube.com/AvayaMentor](http://www.youtube.com/AvayaMentor) and perform one of the following actions:
  - Enter a key word or key words in the **Search Channel** to search for a specific product or topic.
  - Scroll down Playlists, and click the name of a topic to see the available list of videos posted on the website.

 **Note:**

Videos are not available for all products.

---

## Searching a documentation collection

On the Avaya Support website, you can download the documentation library for a specific product and software release to perform searches across an entire document collection. For example, you can perform a single, simultaneous search across the collection to quickly find all occurrences of a particular feature. Use this procedure to perform an index search of your documentation collection.

### Before you begin

- Download the documentation collection zip file to your local computer.
- You must have Adobe Acrobat or Adobe Reader installed on your computer.

### Procedure

1. Extract the document collection zip file into a folder.
2. Navigate to the folder that contains the extracted files and open the file named `<product_name_release>.pdx`.

3. In the Search dialog box, select the option **In the index named <product\_name\_release>.pdx**.
4. Enter a search word or phrase.
5. Select any of the following to narrow your search:
  - Whole Words Only
  - Case-Sensitive
  - Include Bookmarks
  - Include Comments
6. Click **Search**.

The search results show the number of documents and instances found. You can sort the search results by Relevance Ranking, Date Modified, Filename, or Location. The default is Relevance Ranking.

---

## Subscribing to e-notifications

Subscribe to e-notifications to receive an email notification when documents are added to or changed on the Avaya Support website.

### About this task

You can subscribe to different types of general notifications, for example, Product Correction Notices (PCN), which apply to any product or a specific product. You can also subscribe to specific types of documentation for a specific product, for example, Application & Technical Notes for Ethernet Routing Switch 5000 Series.

### Procedure

1. In an Internet browser, go to <https://support.avaya.com>.
2. Type your username and password, and then click **Login**.
3. Under **My Information**, select **SSO login Profile**.
4. Click **E-NOTIFICATIONS**.
5. In the GENERAL NOTIFICATIONS area, select the required documentation types, and then click **UPDATE**.

GENERAL NOTIFICATIONS

1/5 Notifications Selected

End of Sale and/or Manufacturer Support Notices	<input type="checkbox"/>
Product Correction Notices (PCN)	<input checked="" type="checkbox"/>
Product Support Notices	<input type="checkbox"/>
Security Advisories	<input type="checkbox"/>
Services Support Notices	<input type="checkbox"/>

UPDATE >>

6. Click **OK**.
7. In the PRODUCT NOTIFICATIONS area, click **Add More Products**.

PRODUCT NOTIFICATIONS

Show Details

Add More Products

1 Notices

8. Scroll through the list, and then select the product name.
9. Select a release version.
10. Select the check box next to the required documentation types.



The screenshot shows a web interface with two main panels. The left panel, titled "PRODUCTS" with a "My Notifications" link, contains a list of product categories. The right panel, titled "ETHERNET ROUTING SWITCH 5000 SERIES", allows the user to select a release version and choose specific document types to subscribe to.

PRODUCTS	My Notifications
Ethernet Routing Switch 3500 Series	
Ethernet Routing Switch 3510-24T	
Ethernet Routing Switch 4000 Series	
<b>Ethernet Routing Switch 5000 Series</b>	
Ethernet Routing Switch 8300	
Ethernet Routing Switch 8800/8600	
Ethernet Routing Switch RPS 15	
Ethernet Routing Switch Web Switching Module	
Ethernet Switch 325/425 Series	
Ethernet Switch 380	

ETHERNET ROUTING SWITCH 5000 SERIES
Select a Release Version All and Future Releases
Administration and System Programming <input type="checkbox"/>
Application Developer Information <input type="checkbox"/>
Application Notes <input type="checkbox"/>
Application and Technical Notes <input type="checkbox"/>
Declarations of Conformity <input type="checkbox"/>
Documentation Library <input type="checkbox"/>
<b>SUBMIT &gt;&gt;</b>

11. Click **Submit**.

# Glossary

<b>attenuation</b>	The decrease in signal strength in an optical fiber caused by absorption and scattering.
<b>Avaya command line interface (ACLI)</b>	A textual user interface. When you use ACLI, you respond to a prompt by typing a command. After you enter the command, you receive a system response.
<b>bit error rate (BER)</b>	The ratio of the number of bit errors to the total number of bits transmitted in a specific time interval.
<b>cable plant</b>	All the optical elements, such as fiber connectors and splices, between a transmitter and a receiver.
<b>coarse wavelength division multiplexing (CWDM)</b>	A technology that uses multiple optical signals with different wavelengths to simultaneously transmit in the same direction over one fiber, and then separates by wavelength at the distant end.
<b>demultiplexing</b>	The wavelength separation in a wavelength-division multiplexing system. The opposite of multiplexing.
<b>dense wavelength division multiplexing (DWDM)</b>	A technology that uses many optical signals (16 or more) with different wavelengths to simultaneously transmit in the same direction across one fiber, and then separate by wavelength at the distant end.
<b>dispersion</b>	The broadening of input pulses as they travel the length of an optical fiber. The following types of dispersion exist: <ul style="list-style-type: none"><li>• modal dispersion—caused by the many optical path lengths in a multimode fiber</li><li>• chromatic dispersion—caused by the differential delay at various wavelengths in an optical fiber</li><li>• waveguide dispersion—caused by light traveling through both the core and cladding materials in single-mode fibers</li></ul>
<b>Gigabit Ethernet (GbE)</b>	Ethernet technology with speeds up to 10 Gbps.
<b>light emitting diode (LED)</b>	A semiconductor diode that emits light when a current passes through it.

<b>media</b>	A substance that transmits data between ports; usually fiber optic cables or category 5 unshielded twisted pair (UTP) copper wires.
<b>metropolitan area network (MAN)</b>	A broadband network that covers an area larger than a Local Area Network.
<b>multimode fiber (MMF)</b>	A fiber with a core diameter larger than the wavelength of light transmitted that you can use to propagate many modes of light. Commonly used with LED sources for low speed and short distance lengths. Typical core sizes (measured in microns) are 50/125, 62.5/125 and 100/140.
<b>multiplexing</b>	Carriage of multiple channels over a single transmission medium; a process where a dedicated circuit is shared by multiple users. Typically, data streams intersperse on a bit or byte basis (time division), or separate by different carrier frequencies (frequency division).
<b>nanometer (nm)</b>	One billionth of a meter ( $10^{-9}$ meter). A unit of measure commonly used to express the wavelengths of light.
<b>SFP</b>	A hot pluggable, small form-factor pluggable (SFP) transceiver, which is used in Ethernet applications up to 1 Gbps.
<b>SFP+</b>	A hot pluggable, small form-factor pluggable plus (SFP+) transceiver, which is used in Ethernet applications up to 10 Gbps. It is similar in physical appearance to SFP transceivers.
<b>single-mode fiber (SMF)</b>	One of the various light waves transmitted in an optical fiber. Each optical signal generates many modes, but in single-mode fiber only one mode is transmitted. Transmission occurs through a small diameter core (approximately 10 micrometers), with a cladding that is 10 times the core diameter. These fibers have a potential bandwidth of 50 to 100 gigahertz (GHz) per kilometer.
<b>unshielded twisted pair (UTP)</b>	A cable with one or more pairs of twisted insulated copper conductors bound in a single plastic sheath.