

Virtual Services Platform 4000 4450GTX-HT-PWR+ Quick Install Guide

This document provides information and instructions to install and commission a factory-supplied Avaya Virtual Services Platform 4000 4450GTX-HT-PWR+ switch. This hardware model is temperature hardened and designed to withstand industrial-grade high temperatures. You can download all documents referenced in this guide at <http://support.avaya.com>.

Before you start

Confirm that you have the following tools and cables:

- ‡ 3 KLOOLSV VFUHZGULYHU
- ‡ Console cable that matches the console connector on the switch (DB-9 or RJ-45)
- ‡ Electrostatic discharge (ESD) cable

Unpack the equipment and verify package content

Note: Observe ESD precautions when unpacking.

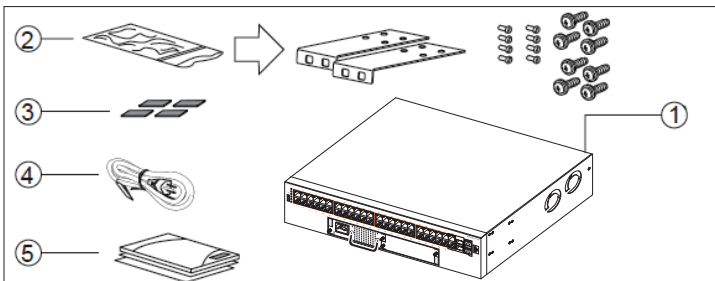

1. Avaya Virtual Services Platform (VSP) 4000 4450GTX-HT-PWR+ switch with one power supply installed.
2. Rack-mounting hardware that includes:
 - a. Rack-mount brackets
 - b. Screws to attach brackets to the switch
 - c. Screws to attach the switch to the equipment rack
3. Rubber footpads.
4. AC power cord with an IEC 60320 C-16 connector. (Note: A power cord is not included for the A variant of the switch.)
5. Documentation that includes:
 - a. Locating the latest software and product release notes (NN46251-106)
 - b. Regulatory Guide (NN46251-105)
 - c. Quick Install Guide (this document)
 - d. China RoHS paper

Verify power supply unit (PSU) specifications

The VSP 4000 4450GTX-HT-PWR+ switch supports two field-replaceable AC PSUs. One PSU is supplied with the chassis. Optionally order an additional PSU for redundancy and load sharing.

VSP 4000 4450GTX-HT-PWR+ AC power and temperature specifications

Specifications	Description																											
PSU Specifications	<p>Primary PSU (without power cord): 1000-watt AC PoE+ high-temperature field-replaceable power supply (replacement order code: EC4005A03-E6)</p> <p>Redundant PSU (without power cord): 1000-watt AC PoE+ high-temperature field-replaceable power supply (replacement order code: EC4005A03-E6)</p> <p>Primary PSU (with North American power cord): 1000-watt AC PoE+ high-temperature field-replaceable power supply (replacement order code: EC4005E03-E6)</p> <p>Redundant PSU (with North American power cord): 1000-watt AC PoE+ high-temperature field-replaceable power supply (replacement order code: EC4005E03-E6)</p> <p>Note: The 1000-watt AC power supply uses the IEC 60320 C16 AC power cord connector.</p>																											
Power over Ethernet (PoE) and Power over Ethernet Plus (PoE+) specifications	<p>The maximum PoE+ wattage is as follows:</p> <table border="1"> <thead> <tr> <th></th> <th>0°C to 50°C</th> <th>50°C to 70°C</th> </tr> </thead> <tbody> <tr> <td>1 PSU</td> <td>860 watts</td> <td>400 watts</td> </tr> <tr> <td>2 PSUs</td> <td>1660 watts</td> <td>832 watts</td> </tr> </tbody> </table> <p>The VSP 4450GTX-HT-PWR+ has 48 ports that are capable of POE and POE+ power support. The following tables list the PoE and PoE+ support based on the operating temperature.</p> <p>1 PSU:</p> <table border="1"> <thead> <tr> <th></th> <th>0°C to 50°C</th> <th>50°C to 70°C</th> </tr> </thead> <tbody> <tr> <td>PoE support on</td> <td>48 ports</td> <td>23 ports</td> </tr> <tr> <td>PoE+ support on</td> <td>26 ports</td> <td>13 ports</td> </tr> </tbody> </table> <p>2 PSUs:</p> <table border="1"> <thead> <tr> <th></th> <th>0°C to 50°C</th> <th>50°C to 70°C</th> </tr> </thead> <tbody> <tr> <td>PoE support on</td> <td>48 ports</td> <td>48 ports</td> </tr> <tr> <td>PoE+ support on</td> <td>48 ports</td> <td>26 ports</td> </tr> </tbody> </table>		0°C to 50°C	50°C to 70°C	1 PSU	860 watts	400 watts	2 PSUs	1660 watts	832 watts		0°C to 50°C	50°C to 70°C	PoE support on	48 ports	23 ports	PoE+ support on	26 ports	13 ports		0°C to 50°C	50°C to 70°C	PoE support on	48 ports	48 ports	PoE+ support on	48 ports	26 ports
	0°C to 50°C	50°C to 70°C																										
1 PSU	860 watts	400 watts																										
2 PSUs	1660 watts	832 watts																										
	0°C to 50°C	50°C to 70°C																										
PoE support on	48 ports	23 ports																										
PoE+ support on	26 ports	13 ports																										
	0°C to 50°C	50°C to 70°C																										
PoE support on	48 ports	48 ports																										
PoE+ support on	48 ports	26 ports																										
Operating temperature specifications	<p>The supported operating temperature is 0°C to 70°C.</p> <p>Caution: To prevent equipment damage, ensure that the operating temperature range is strictly adhered to.</p>																											

(Optional) Install redundant PSU

Use this procedure to optionally install a redundant power supply.

Note: The switch ships with a filler panel in the second power supply position. This filler panel must stay in place if you do not intend to install a second power supply. Each power supply bay must always be populated with either a cover or a power supply for proper air-flow management.

1. If a blanking plate covers the required power supply slot, remove the blanking plate before attempting to insert the power supply.
2. Insert the power supply into a front power supply slot as illustrated.

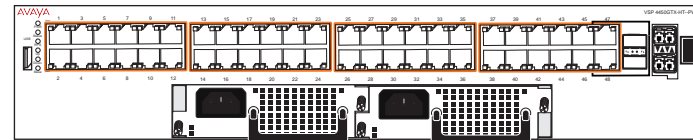

3. Verify that each power supply is fully seated in the slot. Secure the power supply with the two thumb screws.
- Note: The switch chassis can prevent an incorrect installation of a power supply. If you insert a power supply upside down, it will not fully insert and the thumb screws will not engage.
4. After you install a power supply, connect AC power.

Mount the VSP 4000 switch

Caution: To protect the VSP 4000 switch against ESD damage, do the following before you connect the data cables to the device:

- ‡ 8 V H antistatic wrist straps. Ensure that the strap has good skin contact. Do not remove the wrist or ankle strap until the installation is complete.
- ‡ (Q V X U H that you properly ground work surfaces and equipment racks.
- ‡ \$ Y R L G F R Q W D F W E H W Z H H Q H T X L S P H Q W D Q G F O R W K L Q J
- ‡ \$ Y R L G W R X F K L Q J W K H F R Q Q H F W R U S L Q V

a. Table or shelf mounting

1. If you mount the VSP 4000 switch on a table or shelf, attach the included rubber footpads as indicated. The surface must support the combined weight of the switch and attached cables (15-20 pounds [7 to 9 kilograms]).
2. Set the device on a flat surface near an AC power source. Allow at least 2 inches (5.1 cm) of space on all sides for proper air flow, and at least 5 inches (12.7 cm) at the back for power cord clearance.

b. Rack mounting

Prepare the rack:

1. Allocate 2U of vertical space for each switch in an EIA or IEC-standard 19-inch (48.2-centimeter) equipment rack. Ensure that the equipment rack is stable and securely attached to a permanent structure.
2. Ground the rack to the same grounding electrode used by the power service in the area. The ground path must be permanent and must not exceed 1 ohm of resistance from the rack to the grounding electrode. Avaya recommends using a filter or surge suppressor.

Mount the switch:

1. \$ W W D F K D Q / E U D F N H W W R H D F K V L G H R Phillips screwdriver as illustrated.

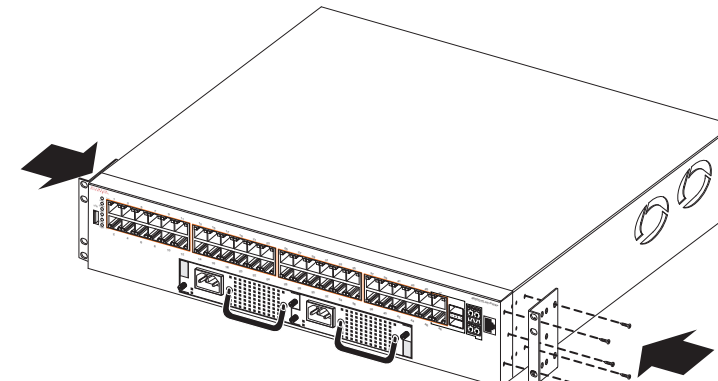

2. Slide the switch into the rack as illustrated. Insert and tighten the rack-mount screws.

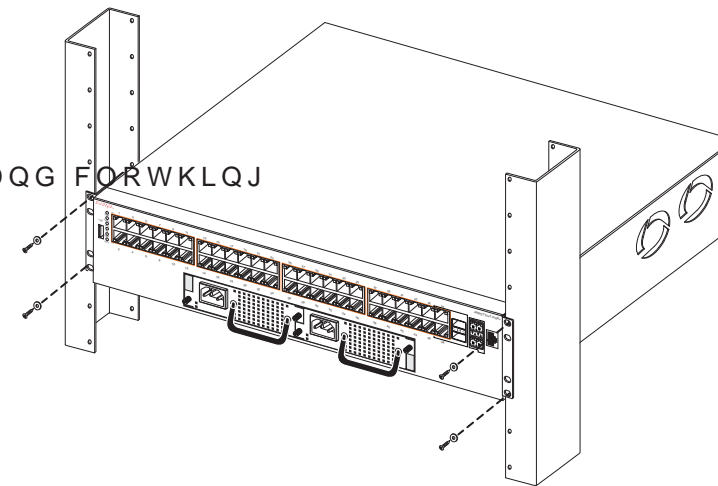

For more details on installing the VSP 4000, see Installing the Avaya Virtual Services Platform 4000 VSP4450GTX-HT-PWR+ (NN46251-304).

Power up

1. Connect the AC power cord to the front of the switch, and then plug the other end of the cord into an AC power outlet.

Note: You will need two power cords if you have installed a redundant PSU.

Warning: You must use a power cord set approved for the 4000 Series switch and the power receptacle type in your country.

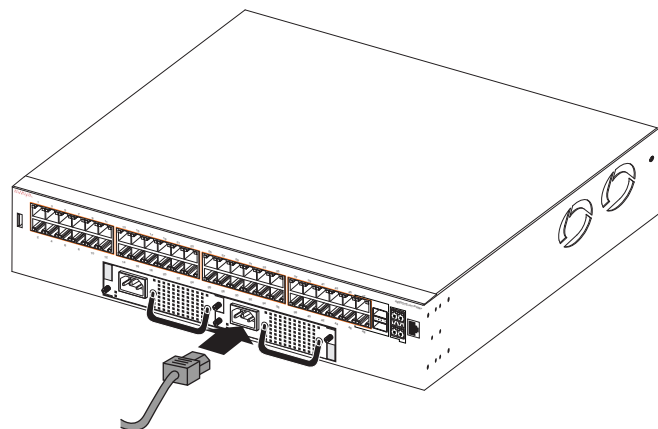

2. Check the front-panel LEDs as the device powers on to be sure the PWR LED is lit. If not, check whether the power cord is plugged in correctly. The switch will power on immediately when it is connected to a suitable AC power source.

Install SFP and SFP+ transceivers

Note: Before installing, ensure that the VSP 4000 switch is operating normally. Verify that the SFP or SFP+ transceivers and network cabling support your network configuration.

1. Select transceivers (SFP/SFP+) that are rated for temperatures of 85°C.
2. Remove the transceiver from the protective packaging.
3. Verify that the transceiver is the correct model for the network configuration.
4. Grasp the transceiver between your thumb and forefinger.
5. Insert the transceiver into the proper SFP/SFP+ slot on the switch as illustrated. Apply a light pressure to the transceiver until it clicks and locks into position in the slot.

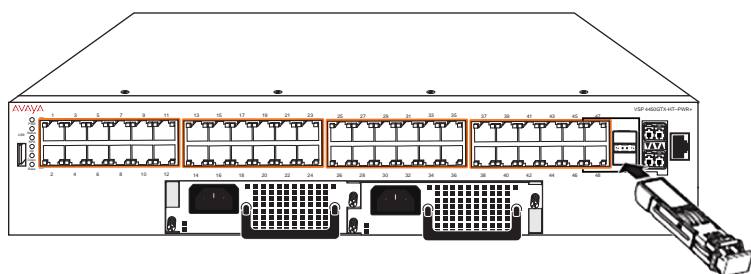

Commissioning the VSP 4000

1 Connect the console cable to the VSP 4000

Console port cabling specifications

Ensure the use of Category 5E or higher specification cabling for 1 Gbps/1000 Mbps operation. RJ-45 console port cables and their Product Engineering Codes (PEC) are as follows:

PEC	Name	Short Description
AL2011022-E6	Avaya RJ-45/DB-9 CONSOLE CABLE	The VSP 4000 has an RJ-45 female connector, so a serial cable with RJ-45 connectors, or a serial cable with a DB-9 female connector on one end and an RJ-45 on the other is required. The maximum length for the console port cable is 25 feet (8.3 meters).
AL2011020-E6	AVAYA RED DB-9 FEMALE TO RJ-45 ADAPTOR	Converts DB-9 male to RJ-45 serial port. The adaptor can be used for PC or device with DB-9 male console port. Also, can be used with Category 5 RJ-45 straight cable to provide console connection.
AL2011021-E6	AVAYA BLUE DB-9 MALE TO RJ-45 ADAPTOR	Converts DB-9 female to RJ-45 serial port. This adaptor can be used to convert DB-9 of AL2011013-E6 console cable to RJ-45.

On your VSP 4000 switch, the console port is the RJ-45 port outlined with a blue border and marked 10101, on the front of your switch (note the side orientation). Use an RJ-45 to DB-9 cable to connect the switch console port to your management terminal. Use adaptors to provide different connection options. The maximum length of a console cable is 25 feet (8.3 meters). The following tables describe the RJ-45 and DB-9 console port pin-out information. You can use the pin-out information to verify or create a console cable for use with your maintenance terminal.

DB-9 console port pin assignments

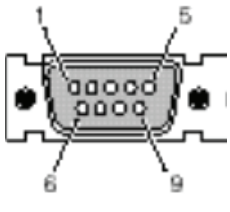
Connector	Pin Number	Signal
	1	Carrier detect (not used)
	2	Transmit data (TXD)
	3	Receive data (RXD)
	4	Data terminal ready (not used)
	5	Signal ground (GND)
	6	Not used
	7	Request to send (not used)
	8	Not used
	9	Ring indicator (not used)

RJ-45 console port pin assignments

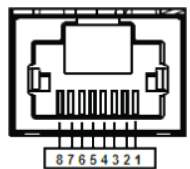
Connector	Pin Number	Signal
	1	Ready to send (RTS) — optional
	2	Data terminal ready (DTR) — optional, can swap or link with pin 8
	3	Transmit data (TXD) — mandatory
	4	Carrier detect (DCD) — optional
	5	Ground (GND) — mandatory
	6	Receive data (RXD) — mandatory
	7	Data set ready (DSR) — optional
	8	Clear to send (CTS) — optional, can swap or link with pin 1.

1. Connect the console cable from the terminal to the console port of the switch to allow initial configuration. Any terminal or PC with the appropriate terminal emulator can be used as the management station.
2. Set the terminal protocol on the terminal or terminal emulation program to VT100 or VT100/ANSI.
3. Connect to the switch using the terminal or terminal emulation application.

Terminal emulation settings

Property	Value
Baud Rate	9600 bps
Data Bits	8
Stop Bits	1
Parity	None
Flow Control	None

2 Configure an in-band VLAN and a management IP interface for the VLAN

Note: In the following procedure you create a VLAN with ID 20 and name Avaya .

1. Create a VLAN:
VSP-4450GTX-HT-PWR+ FRQILJ YODQ FUHDWH QDPH
Avaya type port-mstprstp 0
2. Add VLAN members:
VSP-4450GTX-HT-PWR+ FRQILJ YODQ PHPEHUV DGG
3. Configure a management IP interface for the VLAN (for example, 47.17.123.85):
VSP-4450GTX-HT-PWR+ FRQILJ LQWHUIDFH YODQ
VSP-4450GTX-HT-PWR+ FRQILJ LS DGGUHVV
47.17.123.85 255.255.255.0

Shutting down the VSP 4000

Caution: Before you unplug the AC power cord, always perform the following shutdown procedure. This procedure flushes any pending data to ensure data integrity.

1. Enter the Privileged EXEC command mode:
enable
2. Shut down the VSP 4000:
sys shutdown
When prompted, enter *y* to confirm the shutdown.
3. Before you unplug the power cord, wait until you see the following message:
System Halted, OK to turn off power.

For more information on this and other administration procedures, see Avaya Virtual Services Platform 4000 Administration (NN46251-600).

Recommended reading

For more information, go to <http://support.avaya.com> and download the following VSP 4000 guides:

- Regulatory Information and Locating the Document (NN46251-105)
- Documentation Roadmap (NN46251-100)
- Installation (NN46251-307)
- Quick Start (NN46251-102)
- Release Notes (NN46251-401)
- Administration (NN46251-600)

AVAYA

<http://support.avaya.com>
1-800-242-2121 (U.S.A.)
1-866 GO-AVAYA
1-866-462-8292 (US Sales)

© 2014 Avaya Inc.

Poster part number: 700510122
Release 4.0.40
NN46251-306 01.01