



Release 4.0.50
NN46251-309
Issue 02.02
July 2015

Installation Job Aid for Avaya VSP 4000 4450GSX series

How to get help

To access the complete range of services and support that Avaya provides, go to www.avaya.com.

You can also go to www.avaya.com/support to access the following pages:

- technical documentation
- product training
- technical support

If you purchased a service contract for your Avaya product from a distributor or authorized reseller and you need assistance, contact the technical support staff for that distributor or reseller.

Notices

Notice paragraphs alert you about issues that require your attention. The following paragraphs describe the types of notices used in this guide.

 **Note:**

Notes provide tips and useful information regarding the installation and operation of Avaya products.

 **Electrostatic alert:**

ESD

ESD notices provide information about how to avoid discharge of static electricity and subsequent damage to Avaya products.

 **Caution:**

Caution notices provide information about how to avoid possible service disruption or damage to Avaya products.

 **Warning:**

Warning notices provide information about how to avoid personal injury when working with Avaya products.

 **Voltage:**

Danger — High Voltage notices provide information about how to avoid a situation or condition that can cause serious personal injury or death from high voltage or electric shock.

 **Danger:**

Danger notices provide information about how to avoid a situation or condition that can cause serious personal injury or death.

Safety messages

 **Warning:**

Installation must be performed by qualified service personnel only. Read and follow all warning notices and instructions marked on the product or included in the documentation.

 **Voltage:**

This equipment relies on the building's installation for overcurrent protection. Ensure that a fuse or circuit breaker no larger than 120 VAC, 15 A U.S. (240 VAC, 16 A International) is used on the phase conductors.

 **Caution:**

This device is a Class A product. In a domestic environment, this device can cause radio interference, in which case the user may be required to take appropriate measures.

 **Caution:**

When mounting this device in a rack, do not stack units directly on top of one another in the rack. Each unit must be secured to the rack with appropriate mounting brackets. Mounting brackets are not designed to support multiple units.

 **Voltage:**

Use only power cords that have a grounding path. Without a proper ground, a person who touches the switch is in danger of receiving an electrical shock. Lack of a grounding path to the switch can result in excessive emissions.

 **Warning:**

Disconnecting the power cord is the only way to turn off power to this device. Always connect the power cord in a location that can be reached quickly and safely in case of an emergency.

 **Warning:**

Fiber optic equipment can emit laser or infrared light that can injure your eyes. Never look into an optical fiber or connector port. Always assume that fiber optic cables are connected to a light source.



⚠ Caution:

Risk of high current and board burn out if battery is replaced by an incorrect type. Dispose of used batteries according to the instructions.

⚠ Warning:

The lithium battery is not field replaceable. It must only be removed and replaced by authorized personnel. Contact Avaya Technical Support for assistance if the battery requires replacement.

Before you begin

Ensure the area where you install and use the VSP 4000 switch meets the following environmental requirements:

- Ambient temperature between 32° and 122° F (0° and 50° C)
- Relative humidity between 0% and 95% noncondensing
- No nearby heat sources such as hot air vents or direct sunlight
- No nearby sources of severe electromagnetic noise
- No excessive dust
- Adequate power source within six feet; one 15-Amp circuit required for each power supply
- At least 2 inches (5.08 cm) on all sides of the switch unit for ventilation
- Adequate space at the front and rear of the switch for access to cables

If you are installing a single VSP 4000 switch on a table or shelf, ensure the surface can support at least 15 to 20 pounds (7 to 9 kilograms).

Installing the Avaya VSP 4450GSX series switches

The VSP 4450GSX series consists of the 4450GSX-PWR+, 4450GSX-DC and the TAA compliant versions.

⚠ Warning:

Do not use the ERS to VSP conversion kit (part number EC4810003-3.0) with these chassis . The kit is incompatible with the VSP 4450GSX series switches.

*** Note:**

A factory-supplied 4450GSX series switch has a USB slot but no USB device or cover.

Installing the Avaya VSP 4000 switch on a table or shelf

You can install a single Avaya VSP 4000 switch on any flat surface. The surface must support the combined weight of the switch and attached cables (from 15 and 20 pounds [7 to 9 kilograms]).

To install an Avaya VSP 4000 on a table or shelf, perform this procedure.

1. Attach the included rubber footpads on the bottom of the switch at the locations indicated.

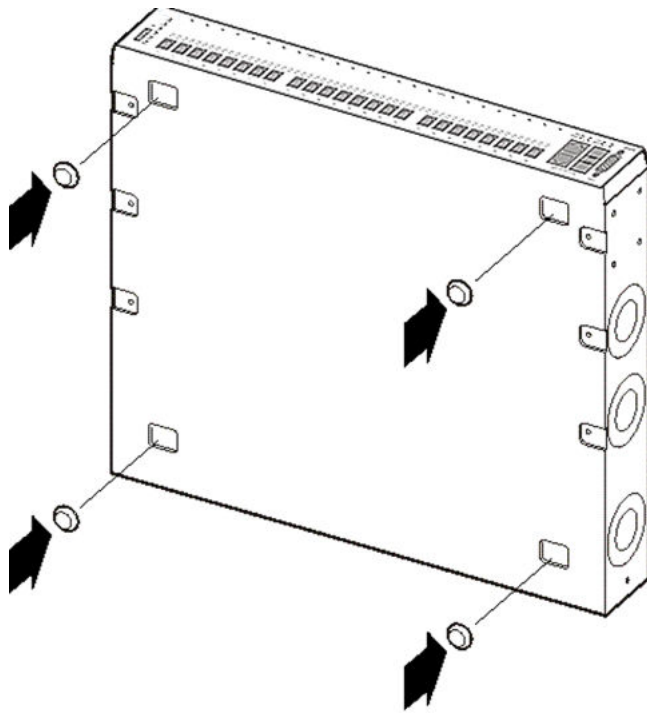

10753FC

2. Set the switch on a table or shelf as illustrated below. Allow at least 2 inches (5.1 centimeters) on each side for proper ventilation and at least 5 inches (12.7 centimeters) at the back for power cord clearance.

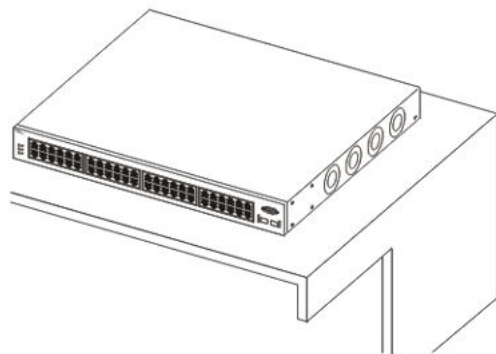

10754FC

Installing the Avaya VSP 4000 switch in an equipment rack

To install an Avaya VSP 4000 switch in an equipment rack, perform this procedure.

Prerequisites for installing the Avaya Virtual Services Platform 4000 in an equipment rack:

- Ensure that you have a space of 1.75 inches (4.45 centimeters) in height for each switch in an EIA or IEC-standard 19-inch (48.2-centimeter) equipment rack.
 - The rack is bolted to the floor and braced if necessary.
 - The rack is grounded to the same grounding electrode used by the power service in the area. The ground path must be permanent and must not exceed 1 Ohm of resistance from the rack to the grounding electrode.
1. Attach the L-bracket to each side of the switch using a #2 Phillips screwdriver as illustrated below.

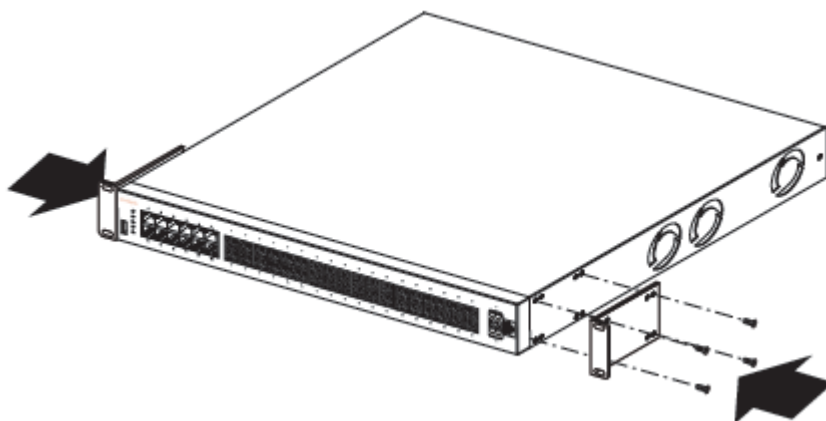

2. Slide the switch into the rack as illustrated.

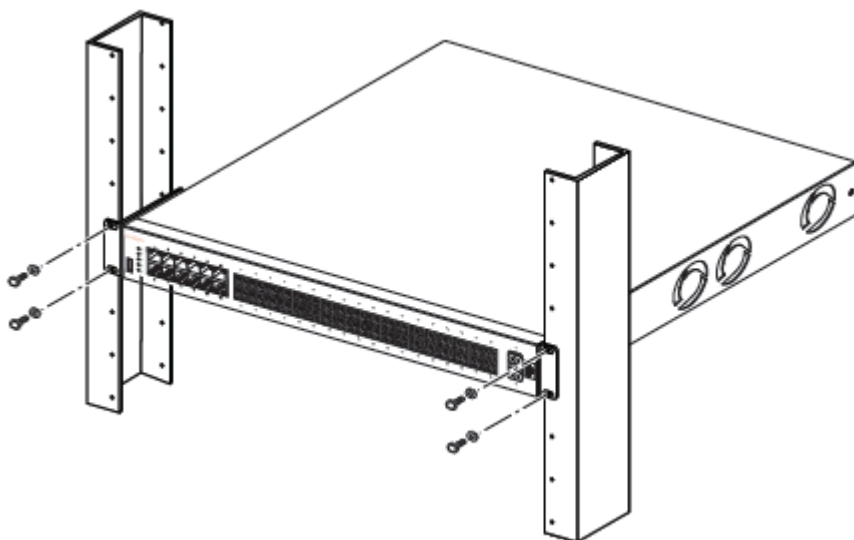

3. Insert and tighten the rack-mount screws.

Installing SFP transceivers

Install SFP transceivers by performing this procedure.

1. Remove the transceiver from the protective packaging.
2. Verify that the transceiver is the correct model for the network configuration.
3. Grasp the transceiver between your thumb and forefinger.
4. Insert the transceiver into the proper module on the switch. Apply a light pressure to the transceiver until it clicks and locks into position in the module.
5. Remove the dust cover from the transceiver optical bores.

Removing SFP transceivers

Remove SFP transceivers by performing this procedure.

1. Disconnect the network fiber cable from the transceiver.
2. Use the locking mechanism on the transceiver to release it. The locking mechanism varies from model to model as illustrated below.

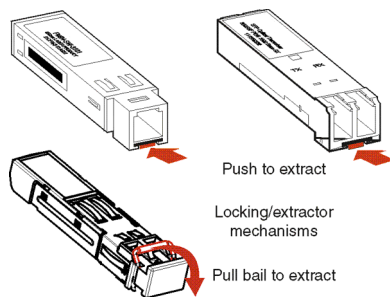

3. Slide the transceiver from the module slot.
4. If the transceiver does not slide easily from the module slot, use a gentle side-to-side rocking motion while firmly pulling the transceiver from the slot.
5. Attach a dust cover over the fiber-optic bores and store the transceiver in a safe place until you need it.

! Important:

Discard transceivers in accordance with the proper laws and regulations.

Power specifications for the Avaya VSP 4450GSX series switches

This section describes the regulatory AC and DC power specifications for the Avaya VSP 4000 4450GSX series switches.

The following table describes the regulatory AC power specifications for the VSP 4450GSX-PWR+ switch and its TAA compliant version. The regulatory AC power specifications are based on the maximum rated capacity of the power supplies and are not based on typical power consumption, which is lower.

Table 1: AC power specifications

	4450GSX-PWR+
Input Current:	12A/6A
Input Voltage (rms):	100 to 240VAC at 50 to 60 Hz
Power Consumption:	248 W maximum
Thermal Rating:	508 BTU/Hr maximum
Inrush Current:	70 A maximum
Turn on Condition:	1 second maximum after application of AC power
! Important: 12 V output rise time, from 10 to 90 per cent, must be the maximum of 50 ms and monotonic under all defined input and output conditions.	

The following table describes the regulatory DC power specifications for the VSP 4450GSX-DC switch. The regulatory DC power specifications are based on the maximum rated capacity of the power supplies and are not based on typical power consumption, which is lower.

Table 2: DC power specifications

	4450GSX DC
Input Current:	25A
Input Voltage:	12VDC
Power Consumption:	<ul style="list-style-type: none">• Typical: 116W• Maximum: 164.6W
Thermal Rating:	508 BTU/Hr

Power supply power specifications for the VSP 4450GSX series switches

The Avaya VSP 4450GSX series switches support two external field replaceable AC and DC power supplies. One power supply ships with the chassis. You can install a secondary power supply to provide redundancy, load sharing, and to add Power over Ethernet Plus (PoE+) power budget on PWR+ models.

AC power supply power specifications

The VSP 4000 4450GSX-PWR+, including the TAA compliant version, supports dual 54V 1000W Power over Ethernet Plus (PoE+) AC power supplies.

! Important:

Ensure that you use only 1000W power supplies (both primary and secondary) on VSP 4000 PWR+ models.



Figure 1: 1000W AC power supply

Connector

The 1000W AC power supply uses an IEC 60320 C16 AC power cord connector. The AC power cord is in close proximity to the hot air exhaust, and supports high operating temperatures.

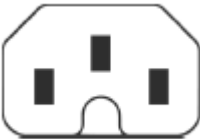

Figure 2: IEC 60320 C16 connector

Power over Ethernet Plus (PoE+) specifications

Table 3: Avaya VSP 4450GSX-PWR+ PoE+ specifications

Maximum PoE+ W	Average PoE+ W on 12 ports
835W with one power supply	17.8W or 32.4W (802.3.at) — 1 power supply
1835W with two power supplies	

- The VSP 4450GSX-PWR+ can support 802.3af 17.8W or 32.4W on each port with one power supply installed. You can add a second power supply for redundancy.

Related Links

[DC power supply power specifications](#) on page 8

DC power supply power specifications

The VSP 4450GSX-DC switch uses field replaceable 300W DC PSUs.

The following table describes the DC power supply specifications for this switch.

Table 4: DC power supply specifications

Description	DC-DC-12V-300 W
Output power	300 W
Input voltage	48 V DC
Input current	10 A
Output voltage	12 V DC
Output current	25 A

Related Links

[Power supply power specifications for the VSP 4450GSX series switches](#) on page 7

Installing the Avaya Virtual Services Platform 4000 power supply

You must install at least one power supply before using the switch. Avaya VSP 4000 models support two field replaceable external power supplies. If supported, you can install an optional second power supply for redundancy, load sharing, or to provide additional PoE+ power budget.

Perform the following procedure to install an external power supply into your switch.

Note:

Avaya VSP 4000 hardware can vary. This procedure only applies to hardware models with field replaceable power supplies.

1. If a blanking plate covers the required power supply slot, remove the blanking plate before attempting to insert the power supply.
2. Insert each power supply into a rear power supply slot.
3. Verify that each power supply is fully seated in the slot. Secure the power supply with the two thumb screws.

Note:

The switch chassis can prevent an incorrect installation of a power supply. If you insert a power supply upside down, it will not fully insert and the thumb screws will not engage.

4. Once you install a power supply, you can proceed with connecting AC power.

Note:

Do not connect an AC and DC power supply in the same chassis. Load sharing may be affected.





Important:

You can hot swap power supplies while the switch is operational. One power supply is required for continued switch operation. PoE+ load reductions can occur if you remove one power supply while the switch is operating with dual power supplies.

Connecting to AC power

To connect AC power to the switch, you need an appropriate AC power cord as described in the following table, also see the following table for plug specifications.

Table 5: International power cord specifications

Country and Plug Specification	Specifications	Typical Plug
Continental Europe: <ul style="list-style-type: none"> • CEE7 standard VII male plug • Harmonized cord (HAR marking on the outside of the cord jacket to comply with the CENELEC Harmonized Document HD-21) 	<ul style="list-style-type: none"> • 220 or 230VAC • 50 Hz • Single phase 	 2220A
United States of America, Canada, and Japan: <ul style="list-style-type: none"> • NEMA5-15P male plug • UL-recognized (UL stamped on cord jacket) • CSA-certified (CSA label secured to the cord) 	<ul style="list-style-type: none"> • 100 or 120VAC • 50–60 Hz • Single phase 	 2270A
United Kingdom: <ul style="list-style-type: none"> • BS1363 male plug with fuse • Harmonized cord 	<ul style="list-style-type: none"> • 240VAC • 50 Hz • Single phase 	 2260A
Australia: <ul style="list-style-type: none"> • AS3112-1981 male plug 	<ul style="list-style-type: none"> • 240VAC • 50 Hz • Single phase 	 2250A

Danger:

Using power cords with a proper grounding path

Use only power cords that have a grounding path. Without a proper ground, a person who touches the switch is in danger of receiving an electrical shock. Lack of a grounding path to the switch can result in excessive emissions.

Connecting to DC power

To connect DC power to the switch, use the short power cable that is provided with the switch.

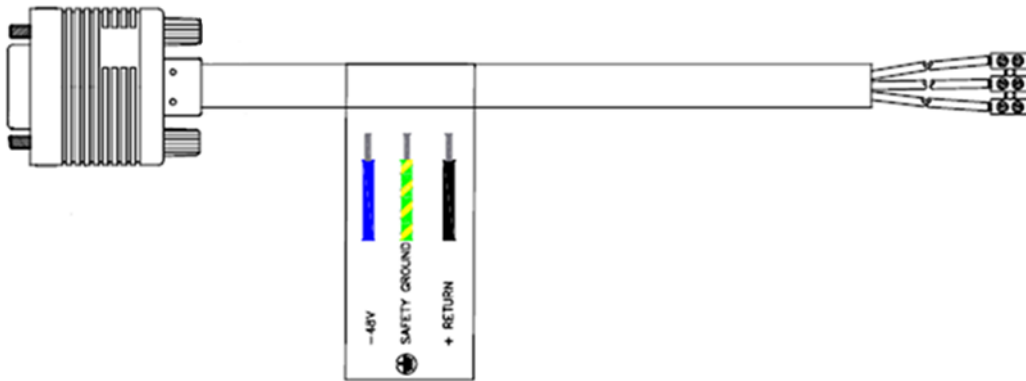

Figure 3: DC power cable

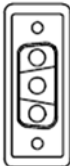

Figure 4: DC power cord housing unit with terminals