



# **Installing Transceivers and Optical Components on Avaya Virtual Services Platform 7200 Series and 8000 Series**

Release 4.2.1  
NN47227-301  
Issue 04.04  
October 2015

## Notice

While reasonable efforts have been made to ensure that the information in this document is complete and accurate at the time of printing, Avaya assumes no liability for any errors. Avaya reserves the right to make changes and corrections to the information in this document without the obligation to notify any person or organization of such changes.

## Documentation disclaimer

"Documentation" means information published by Avaya in varying mediums which may include product information, operating instructions and performance specifications that Avaya may generally make available to users of its products and Hosted Services. Documentation does not include marketing materials. Avaya shall not be responsible for any modifications, additions, or deletions to the original published version of documentation unless such modifications, additions, or deletions were performed by Avaya. End User agrees to indemnify and hold harmless Avaya, Avaya's agents, servants and employees against all claims, lawsuits, demands and judgments arising out of, or in connection with, subsequent modifications, additions or deletions to this documentation, to the extent made by End User.

## Link disclaimer

Avaya is not responsible for the contents or reliability of any linked websites referenced within this site or documentation provided by Avaya. Avaya is not responsible for the accuracy of any information, statement or content provided on these sites and does not necessarily endorse the products, services, or information described or offered within them. Avaya does not guarantee that these links will work all the time and has no control over the availability of the linked pages.

## Warranty

Avaya provides a limited warranty on Avaya hardware and software. Refer to your sales agreement to establish the terms of the limited warranty. In addition, Avaya's standard warranty language, as well as information regarding support for this product while under warranty is available to Avaya customers and other parties through the Avaya Support website: <http://support.avaya.com> or such successor site as designated by Avaya. Please note that if You acquired the product(s) from an authorized Avaya Channel Partner outside of the United States and Canada, the warranty is provided to You by said Avaya Channel Partner and not by Avaya.

## Licenses

THE SOFTWARE LICENSE TERMS AVAILABLE ON THE AVAYA WEBSITE, [HTTP://SUPPORT.AVAYA.COM/LICENSEINFO](http://support.avaya.com/licenseinfo) OR SUCH SUCCESSOR SITE AS DESIGNATED BY AVAYA, ARE APPLICABLE TO ANYONE WHO DOWNLOADS, USES AND/OR INSTALLS AVAYA SOFTWARE, PURCHASED FROM AVAYA INC., ANY AVAYA AFFILIATE, OR AN AVAYA CHANNEL PARTNER (AS APPLICABLE) UNDER A COMMERCIAL AGREEMENT WITH AVAYA OR AN AVAYA CHANNEL PARTNER. UNLESS OTHERWISE AGREED TO BY AVAYA IN WRITING, AVAYA DOES NOT EXTEND THIS LICENSE IF THE SOFTWARE WAS OBTAINED FROM ANYONE OTHER THAN AVAYA, AN AVAYA AFFILIATE OR AN AVAYA CHANNEL PARTNER; AVAYA RESERVES THE RIGHT TO TAKE LEGAL ACTION AGAINST YOU AND ANYONE ELSE USING OR SELLING THE SOFTWARE WITHOUT A LICENSE. BY INSTALLING, DOWNLOADING OR USING THE SOFTWARE, OR AUTHORIZING OTHERS TO DO SO, YOU, ON BEHALF OF YOURSELF AND THE ENTITY FOR WHOM YOU ARE INSTALLING, DOWNLOADING OR USING THE SOFTWARE (HEREINAFTER REFERRED TO INTERCHANGEABLY AS "YOU" AND "END USER"), AGREE TO THESE TERMS AND CONDITIONS AND CREATE A BINDING CONTRACT BETWEEN YOU AND AVAYA INC. OR THE APPLICABLE AVAYA AFFILIATE ("AVAYA").

Avaya grants You a license within the scope of the license types described below, with the exception of Heritage Nortel Software, for which the scope of the license is detailed below. Where the order documentation does not expressly identify a license type, the applicable license will be a Designated System License. The

applicable number of licenses and units of capacity for which the license is granted will be one (1), unless a different number of licenses or units of capacity is specified in the documentation or other materials available to You. "Software" means computer programs in object code, provided by Avaya or an Avaya Channel Partner, whether as stand-alone products, pre-installed on hardware products, and any upgrades, updates, patches, bug fixes, or modified versions thereto. "Designated Processor" means a single stand-alone computing device. "Server" means a Designated Processor that hosts a software application to be accessed by multiple users. "Instance" means a single copy of the Software executing at a particular time: (i) on one physical machine; or (ii) on one deployed software virtual machine ("VM") or similar deployment.

## Licence types

Designated System(s) License (DS). End User may install and use each copy or an Instance of the Software only on a number of Designated Processors up to the number indicated in the order. Avaya may require the Designated Processor(s) to be identified in the order by type, serial number, feature key, Instance, location or other specific designation, or to be provided by End User to Avaya through electronic means established by Avaya specifically for this purpose.

## Heritage Nortel Software

"Heritage Nortel Software" means the software that was acquired by Avaya as part of its purchase of the Nortel Enterprise Solutions Business in December 2009. The Heritage Nortel Software currently available for license from Avaya is the software contained within the list of Heritage Nortel Products located at <http://support.avaya.com/LicenseInfo> under the link "Heritage Nortel Products" or such successor site as designated by Avaya. For Heritage Nortel Software, Avaya grants You a license to use Heritage Nortel Software provided hereunder solely to the extent of the authorized activation or authorized usage level, solely for the purpose specified in the Documentation, and solely as embedded in, for execution on, or for communication with Avaya equipment. Charges for Heritage Nortel Software may be based on extent of activation or use authorized as specified in an order or invoice.

## Copyright

Except where expressly stated otherwise, no use should be made of materials on this site, the Documentation, Software, Hosted Service, or hardware provided by Avaya. All content on this site, the documentation, Hosted Service, and the product provided by Avaya including the selection, arrangement and design of the content is owned either by Avaya or its licensors and is protected by copyright and other intellectual property laws including the sui generis rights relating to the protection of databases. You may not modify, copy, reproduce, republish, upload, post, transmit or distribute in any way any content, in whole or in part, including any code and software unless expressly authorized by Avaya. Unauthorized reproduction, transmission, dissemination, storage, and or use without the express written consent of Avaya can be a criminal, as well as a civil offense under the applicable law.

## Third Party Components

"Third Party Components" mean certain software programs or portions thereof included in the Software or Hosted Service may contain software (including open source software) distributed under third party agreements ("Third Party Components"), which contain terms regarding the rights to use certain portions of the Software ("Third Party Terms"). As required, information regarding distributed Linux OS source code (for those products that have distributed Linux OS source code) and identifying the copyright holders of the Third Party Components and the Third Party Terms that apply is available in the products, Documentation or on Avaya's website at: <http://support.avaya.com/Copyright> or such successor site as designated by Avaya. You agree to the Third Party Terms for any such Third Party Components.

## Preventing Toll Fraud

"Toll Fraud" is the unauthorized use of your telecommunications system by an unauthorized party (for example, a person who is not a corporate employee, agent, subcontractor, or is not working on your company's behalf). Be aware that there can be a risk of Toll Fraud associated with your system and that, if Toll Fraud occurs, it can

result in substantial additional charges for your telecommunications services.

### **Avaya Toll Fraud intervention**

If You suspect that You are being victimized by Toll Fraud and You need technical assistance or support, call Technical Service Center Toll Fraud Intervention Hotline at +1-800-643-2353 for the United States and Canada. For additional support telephone numbers, see the Avaya Support website: <http://support.avaya.com> or such successor site as designated by Avaya. Suspected security vulnerabilities with Avaya products should be reported to Avaya by sending mail to: [securityalerts@avaya.com](mailto:securityalerts@avaya.com).

### **Downloading Documentation**

For the most current versions of Documentation, see the Avaya Support website: <http://support.avaya.com>, or such successor site as designated by Avaya.

### **Contact Avaya Support**

See the Avaya Support website: <http://support.avaya.com> for product or Hosted Service notices and articles, or to report a problem with your Avaya product or Hosted Service. For a list of support telephone numbers and contact addresses, go to the Avaya Support website: <http://support.avaya.com> (or such successor site as designated by Avaya), scroll to the bottom of the page, and select Contact Avaya Support.

### **Trademarks**

The trademarks, logos and service marks ("Marks") displayed in this site, the Documentation, Hosted Service(s), and product(s) provided by Avaya are the registered or unregistered Marks of Avaya, its affiliates, or other third parties. Users are not permitted to use such Marks without prior written consent from Avaya or such third party which may own the Mark. Nothing contained in this site, the Documentation, Hosted Service(s) and product(s) should be construed as granting, by implication, estoppel, or otherwise, any license or right in and to the Marks without the express written permission of Avaya or the applicable third party.

Avaya is a registered trademark of Avaya Inc.

All non-Avaya trademarks are the property of their respective owners. Linux<sup>®</sup> is the registered trademark of Linus Torvalds in the U.S. and other countries.

# Contents

<b>Chapter 1: Introduction</b> .....	6
Purpose.....	6
Related resources.....	6
Documentation.....	6
Training.....	6
Viewing Avaya Mentor videos.....	6
Subscribing to e-notifications.....	7
Support.....	9
Searching a documentation collection.....	9
<b>Chapter 2: New in this release</b> .....	11
VOSS 4.2.1.....	11
Features.....	11
Other changes for VOSS 4.2.1.....	11
VOSS 4.2.....	12
Features.....	12
Other changes.....	12
<b>Chapter 3: Safety and equipment care information</b> .....	13
Fiber optic equipment care.....	13
Fiber optic cable care.....	13
Fiber optic connector care.....	14
Cleaning single connectors.....	15
Cleaning duplex connectors.....	16
Cleaning receptacles.....	17
<b>Chapter 4: SFP</b> .....	19
SFP transceivers.....	19
Selecting an SFP.....	20
Installing an SFP.....	22
Removing an SFP.....	24
SFP specifications.....	25
SFP labels.....	26
General SFP specifications.....	26
Supported SFP transceivers.....	26
<b>Chapter 5: SFP+</b> .....	38
SFP+ transceivers.....	38
Selecting an SFP+.....	39
Installing an SFP+.....	41
Removing an SFP+.....	43
SFP+ specifications.....	44
SFP+ labels.....	45

- General SFP+ specifications..... 45
- Supported SFP+ transceivers..... 46
- SFP+ cable assembly specifications..... 58
- SFP+ direct attach cable specifications..... 58
- Chapter 6: QSFP+..... 59**
  - QSFP+ transceivers..... 59
  - Selecting a QSFP+..... 60
  - Installing a QSFP+ transceiver..... 61
  - Removing a QSFP+ transceiver..... 63
  - QSFP+ transceiver specifications..... 64
  - QSFP+ transceiver labels..... 64
  - General QSFP+ transceiver specifications..... 65
  - Supported QSFP+ transceivers..... 65
  - QSFP+ cable assembly specifications..... 71
  - QSFP+ breakout cable specifications..... 71
  - QSFP+ to QSFP+ 40–gigabit direct attach cable specifications..... 72
- Chapter 7: Translations of safety messages..... 73**
  - Class A electromagnetic interference warning statement..... 73
  - Electrostatic discharge caution statement..... 74
  - Laser eye safety danger statement..... 75
  - Laser eye safety connector inspection danger statement..... 76
  - Connector cleaning safety danger statement..... 77
  - Optical fiber damage warning statement..... 78
  - Optical fiber connector damage warning statement..... 79
  - SFP damage warning statement..... 81
- Glossary..... 83**

# Chapter 1: Introduction

---

## Purpose

This document is used to select, install, and remove Small Form Factor Pluggable (SFP), Small Form Factor Pluggable plus (SFP+), and Quad Small Form Factor Pluggable plus (QSFP+). Specifications for each supported device are included.

This document is renamed to *Installing Transceivers and Optical Components on Avaya Virtual Services Platform 7200 Series and 8000 Series*, NN47227-301. Avaya Virtual Services Platform 8000 Series includes Avaya Virtual Services Platform 8200 and Avaya Virtual Services Platform 8400.

---

## Related resources

---

### Documentation

See the *Documentation Reference for Avaya Virtual Services Platform 7200 Series and 8000 Series*, NN47227-100 for a list of the documentation for this product.

---

### Training

Ongoing product training is available. For more information or to register, you can access the Web site at <http://avaya-learning.com/>.

---

### Viewing Avaya Mentor videos

Avaya Mentor videos provide technical content on how to install, configure, and troubleshoot Avaya products.

#### About this task

Videos are available on the Avaya Support website, listed under the video document type, and on the Avaya-run channel on YouTube.

## Procedure

- To find videos on the Avaya Support website, go to <http://support.avaya.com> and perform one of the following actions:
  - In **Search**, type `Avaya Mentor Videos` to see a list of the available videos.
  - In **Search**, type the product name. On the Search Results page, select **Video** in the **Content Type** column on the left.
- To find the Avaya Mentor videos on YouTube, go to [www.youtube.com/AvayaMentor](http://www.youtube.com/AvayaMentor) and perform one of the following actions:
  - Enter a key word or key words in the **Search Channel** to search for a specific product or topic.
  - Scroll down Playlists, and click the name of a topic to see the available list of videos posted on the website.

 **Note:**

Videos are not available for all products.

---

## Subscribing to e-notifications

Subscribe to e-notifications to receive an email notification when documents are added to or changed on the Avaya Support website.

### About this task

You can subscribe to different types of general notifications, for example, Product Correction Notices (PCN), which apply to any product or a specific product. You can also subscribe to specific types of documentation for a specific product, for example, Application & Technical Notes for Virtual Services Platform 7000.

### Procedure

1. In an Internet browser, go to <https://support.avaya.com>.
2. Type your username and password, and then click **Login**.
3. Under **My Information**, select **SSO login Profile**.
4. Click **E-NOTIFICATIONS**.
5. In the GENERAL NOTIFICATIONS area, select the required documentation types, and then click **UPDATE**.

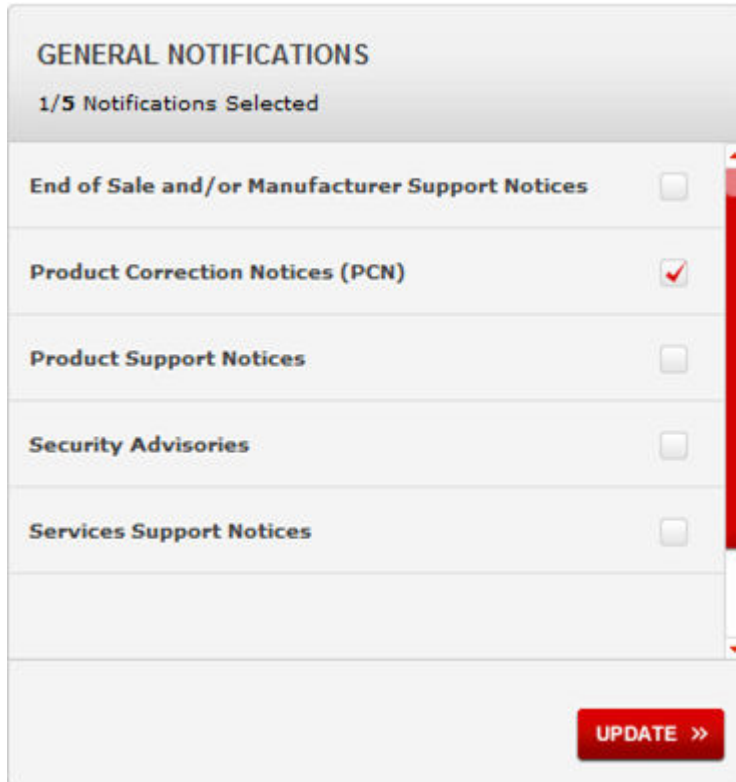

6. Click **OK**.
7. In the **PRODUCT NOTIFICATIONS** area, click **Add More Products**.

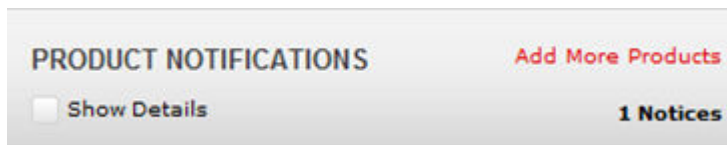

8. Scroll through the list, and then select the product name.
9. Select a release version.
10. Select the check box next to the required documentation types.



The screenshot shows two panels. The left panel, titled 'PRODUCTS', has a 'My Notifications' link in the top right. It contains a list of products: Virtual Services Platform 7000, Virtualization Provisioning Service, Visual Messenger™ for OCTEL® 250/350, Visual Vectors, Visualization Performance and Fault Manager, Voice Portal, Voice over IP Monitoring, W310 Wireless LAN Gateway, WLAN 2200 Series, and WLAN Handset 2200 Series. The right panel, titled 'VIRTUAL SERVICES PLATFORM 7000', has a 'Select a Release Version' dropdown menu set to 'All and Future'. Below this are several items with checkboxes: Administration and System Programming, Application Developer Information, Application Notes, Application and Technical Notes (checked), Declarations of Conformity, and Documentation Library (checked). A red 'SUBMIT >>' button is at the bottom right of the right panel.

11. Click **Submit**.

---

## Support

Go to the Avaya Support website at <http://support.avaya.com> for the most up-to-date documentation, product notices, and knowledge articles. You can also search for release notes, downloads, and resolutions to issues. Use the online service request system to create a service request. Chat with live agents to get answers to questions, or request an agent to connect you to a support team if an issue requires additional expertise.

---

## Searching a documentation collection

On the Avaya Support website, you can download the documentation library for a specific product and software release to perform searches across an entire document collection. For example, you can perform a single, simultaneous search across the collection to quickly find all occurrences of a particular feature. Use this procedure to perform an index search of your documentation collection.

### Before you begin

- Download the documentation collection zip file to your local computer.
- You must have Adobe Acrobat or Adobe Reader installed on your computer.

### Procedure

1. Extract the document collection zip file into a folder.
2. Navigate to the folder that contains the extracted files and open the file named `<product_name_release>.pdx`.

3. In the Search dialog box, select the option **In the index named <product\_name\_release>.pdx.**
4. Enter a search word or phrase.
5. Select any of the following to narrow your search:
  - Whole Words Only
  - Case-Sensitive
  - Include Bookmarks
  - Include Comments
6. Click **Search**.

The search results show the number of documents and instances found. You can sort the search results by Relevance Ranking, Date Modified, Filename, or Location. The default is Relevance Ranking.

# Chapter 2: New in this release

The following sections detail what is new in *Installing Transceivers and Optical Components on Avaya Virtual Services Platform 7200 Series and 8000 Series*, NN47227-301.

---

## VOSS 4.2.1

---

### Features

See the following sections for information about feature changes.

#### **10GBASE-BX SFP+**

VOSS 4.2.1 release introduces support for 10GBASE-BX SFP+ bi-directional SFP+ Ethernet transceiver. For more information, see [10GBASE-BX SFP+ specifications](#) on page 57.

#### **QSFP+ to four SFP+ 10-gigabit Active breakout cable (BOC)**

VOSS 4.2.1 release supports QSFP+ to four SFP+ 10-gigabit Active breakout cable of 10 meter length. For more information, see [QSFP+ breakout cable specifications](#) on page 71.

#### **QSFP+ to QSFP+ 40-gigabit Active DAC**

VOSS 4.2.1 release supports QSFP+ to QSFP+ 40-gigabit Active DAC (10 meter). For more information, see [QSFP+ to QSFP+ 40-gigabit direct attach cable specifications](#) on page 72.

#### **40GBASE-LM4 QSFP+**

VOSS 4.2.1 release introduces support for 40GBASE-LM4 QSFP+ Ethernet transceiver. For more information, see [40GBASE-LM4 QSFP+ specifications](#) on page 68.

#### **40GBASE-ER4 QSFP+**

VOSS 4.2.1 release introduces support for 40GBASE-ER4 QSFP+ Ethernet transceiver. For more information, see [40GBASE-ER4 QSFP+ specifications](#) on page 69.

---

### Other changes for VOSS 4.2.1

## VSP 7200 Series

The VSP 7200 Series hardware is introduced in VOSS 4.2.1 release. The VSP 7200 Series models include VSP 7254XSQ and VSP 7254XTQ.

---

# VOSS 4.2

---

## Features

See the following sections for information about feature changes.

### QSFP+ cable assembly specifications

This section provides cable assembly specifications for the supported 40 gigabit QSFP+ transceiver model. For more information, see, [QSFP+ cable assembly specifications](#) on page 71.

### QSFP+ breakout cable specifications

The QSFP+ to four SFP+ 10 gigabit Breakout Cable (BOC) assembly directly connects one QSFP+ port to four SFP+ ports.

For more information, see, [QSFP+ breakout cable specifications](#) on page 71.

### QSFP+ to QSFP+ 40 gigabit direct attach cable specifications

The QSFP+ to QSFP+ 40 gigabit Direct Attach Cable (DAC) assembly directly connects two QSFP+ ports. The new .5m cable is added in this release.

For more information, see, [QSFP+ to QSFP+ 40-gigabit direct attach cable specifications](#) on page 72.

---

## Other changes

See the following sections about the changes that are not feature related.

### SFP+

Created new section for SFP+ cable assembly specification.

For more information, see [SFP+ cable assembly specifications](#) on page 58.

# Chapter 3: Safety and equipment care information

This chapter contains important safety and regulatory information. Read this section before you install Small Form Factor Pluggable (SFP), Small Form Factor Pluggable plus (SFP+), and Quad Small Form Factor Pluggable plus (QSFP+).

---

## Fiber optic equipment care

Use the information in this section to properly maintain and care for fiber optic equipment.

Transceivers are static sensitive.

Dust contamination can reduce the performance of optical parts in transceivers. When you store a transceiver, or after you disconnect it from a fiber optic cable, always keep a dust cover over the optical bore.

Dispose of this product according to all national laws and regulations.

To prevent equipment damage, observe the following electrostatic discharge (ESD) precautions when you handle or install the components:

- Ground yourself and the equipment to an earth or building ground. Use a grounded workbench mat (or foam that dissipates static charge) and a grounding wrist strap. The wrist strap must touch the skin and you must ground it through a one megaohm resistor.
- Do not touch anyone who is not grounded
- Leave all components in their ESD-safe packaging until installation, and use only a static-shielding bag for all storage, transport, and handling.

Clear the area of synthetic materials such as polyester, plastic, vinyl, or styrofoam because these materials carry static electricity that damages the equipment.

---

## Fiber optic cable care

Although reinforcing material and plastic insulation protects the glass fiber in fiber optic cable, it is subject to damage.

Use the following precautions to avoid damaging the glass fiber:

- Do not kink, knot, or vigorously flex the cable.
- Do not bend the cable to less than a 40 mm radius.
- Do not stand on fiber optic cable; keep the cable off the floor.
- Do not pull fiber optic cable harder than you do a cable containing copper wire of comparable size.
- Do not allow a static load of more than a few pounds on a section of the cable.
- Place protective caps on fiber optic connectors that are not in use.
- Store unused fiber optic patch cables in a cabinet, on a cable rack, or flat on a shelf.

Frequent overstressing of fiber optic cable causes progressive degeneration that leads to failure.

If you suspect damage to a fiber optic cable, either due to mishandling or an abnormally high error rate observed in one direction, reverse the cable pairs. If the high error rate appears in the other direction, replace the cable.

 **Warning:**

**Risk of equipment damage**

Do not crush fiber optic cable. If fiber optic cable is in the same tray or duct with large, heavy electrical cables, the weight of the electrical cable can damage the fiber optic cable.

---

## Fiber optic connector care

Before you connect fiber optic connectors to transmission equipment, test equipment, patch panels, or other connectors, ensure fiber optic connectors are clean. The performance of an optical fiber connector depends on how clean the connector and coupling are at the time of connection.

A damaged or dirty connector can damage a connector with which it pairs. A connector must be clean before you insert it into a transmitter or receiver.

Never clean an optical connector while it carries light. Optical power can cause ignition of the cleaning material when it contacts the end of the optical connector and can destroy the connector. Typical cleaning materials, for example, tissues saturated with alcohol, combust almost instantaneously after you expose them to optical power levels of +15 dBm or higher.

Visually inspect the connector to determine cleanliness and to determine if it needs replacing. You must replace a connector that has a scratch across the core, or a scratch that appears to end in the core.

The proper connector cleaning method depends on the connector contaminants:

- Judge cleanliness by visual inspection with a fiber microscope. First inspect the connector, and then clean as required.

**⚠ Danger:****Risk of eye injury**

When you inspect a connector, ensure that light sources are off. The light source in fiber optic cables can damage your eyes.

- If you suspect only the possibility of dust particles, for example, if you leave a connector uncapped in a clean environment, use high-quality canned air or a reel cleaner, for example, a Cletop, to clean the connector. A reel cleaner is a good choice to ensure that no dust contaminates the connector.
- If the connector is visibly dirty or you suspect contamination by chemicals (for example, matching gel), use high-quality alcohol and canned air to clean the connector. This method is the most thorough cleaning method. In some cases, a reel cleaner can suffice.

The more surface manipulation you apply to the connector, the more likely you are to damage the connector.

When you insert a connector ferrule into a connector or adapter, ensure that the ferrule tip does not touch the outside of the mating connector or adapter. This action can produce scratches and dirt deposits on the connector.

To help prevent connectors from collecting dust, cover them when not in use. To avoid the transfer of oil or other contaminants from your fingers to the end face of the ferrule, handle connectors with care. Do not touch the connector end face.

## Cleaning single connectors

Clean connectors so that the optical signal is minimally attenuated by the connector.

Perform this procedure if you suspect more than dust contamination.

**Before you begin**

- You need a lens-grade, lint-free tissue, for example, Kimwipes.
- You need an optical-grade isopropyl alcohol (IPA) (98% or more pure).
- You need a high-quality canned compressed air with extension tube.

Compressed air must be free of dust, water, and oil, or filmy deposits or scratches on the surface of the connector can result.

- You need a fiber optic microscope to inspect connectors.

**⚠ Danger:****Risk of eye injury**

When you inspect a connector, ensure that light sources are off. The light source used in fiber optic cables can damage your eyes.

To avoid getting debris in your eyes, wear safety glasses when you work with the canned air duster.

To avoid eye irritation on contact, wear safety glasses when you work with isopropyl alcohol.

## Procedure

1. Remove dust or debris by applying canned air to the cylindrical and end-face surfaces of the connector.
2. Gently wipe the cylindrical and end-face surfaces with a tissue dampened with optical-grade isopropyl alcohol.
3. Gently wipe the cylindrical and end-face surfaces with a dry tissue.

### Important:

Do not let the IPA evaporate; wipe it dry immediately. Alcohols can leave a residue that is difficult to remove.

4. Dry the connector surfaces by applying canned air.
5. Inspect the connector to ensure it is clean and undamaged.

To prevent contamination, do not touch the connector surfaces after cleaning; and cover connectors with dust caps if they are not in use.

---

## Cleaning duplex connectors

Clean connectors so that the optical signal is minimally attenuated by the connector.

Perform this procedure when you suspect more than dust contamination.

### Before you begin

- You need a lens-grade, lint-free tissue, for example, Kimwipes.
- You need an optical-grade isopropyl alcohol (IPA) (98% or more pure).
- You need a high-quality canned compressed air with extension tube.

Compressed air must be free of dust, water, and oil, or filmy deposits or scratches on the surface of the connector can result.

- You need a fiber optic microscope to inspect connectors.

### About this task

#### Danger:

#### Risk of eye injury

When you inspect a connector, ensure that light sources are off. The light source in fiber optic cables can damage your eyes.



To avoid getting debris in your eyes, wear safety glasses when you work with the canned air duster.

To avoid eye irritation on contact, wear safety glasses when you work with isopropyl alcohol.

## Procedure

1. Remove or retract the shroud.

On removable shroud connectors, hold the shroud on the top and bottom at the letter designation, apply medium pressure, and then pull it free from the connector body. Do not discard the shroud.

### OR

On retractable shroud connectors, hold the shroud in the retracted position.

2. Remove dust or debris by applying canned air to the cylindrical and end-face surfaces of the connector.
3. Gently wipe the cylindrical and end-face surfaces of both ferrules using a tissue saturated with optical-grade isopropyl alcohol.
4. Gently wipe the cylindrical and end-face surfaces with a dry tissue.

### Important:

Do not let the IPA evaporate; wipe it dry immediately. Alcohols can leave a residue that is difficult to remove.

5. Blow dry the connector surfaces with canned air.
6. Inspect the connector to ensure it is clean and undamaged.
7. Using care to not touch the clean ferrules, gently push the shroud back onto the connector until it seats and locks in place.

---

## Cleaning receptacles

Clean connector receptacles or ports so that the optical signal is minimally attenuated by the connection.

### Before you begin

- You need an optical-grade isopropyl alcohol (IPA) (98% or more pure).
- You need cleaning swabs (also called cleaning sticks or wands).
- You need a high-quality canned compressed air with extension tube.

Compressed air must be free of dust, water, and oil, or filmy deposits or scratches on the surface of the connector can result.

 **Warning:**

**Risk of equipment damage**

To avoid contamination, only clean optical ports if you see evidence of contamination or reduced performance exists, or during their initial installation.

To prevent oil contamination of connectors, use only high-quality canned compressed air.

Do not allow the air extension tube to touch the bottom of the optical port.

**Procedure**

1. Remove dust or debris by blowing canned air into the optical port of the device using the canned air extension tube.
2. Clean the optical port by inserting a wand moistened with alcohol into the receptacle and rotating it.  
Use each cleaning wand to clean only one optical port.
3. Dry the optical port by inserting a dry wand into the receptacle and rotating it.

 **Important:**

Do not let the IPA evaporate; wipe it dry immediately. Alcohols can leave a residue that is difficult to remove.

4. Remove lint by blowing compressed air into the optical port.
5. Reconnect the optical connector and check for proper function.

If you do not reinstall the connector, use a protective cap.

If problems persist, ensure that the connector or receptacle is free from damage.

# Chapter 4: SFP

This chapter provides installation procedures and specifications for Small Form Factor Pluggable (SFP) transceivers.

---

## SFP transceivers

This section describes how to select and install Small Form Factor Pluggable (SFP) transceivers.

Use an SFP to connect a device motherboard to a fiber optic or unshielded twisted pair network cable. The SFP transceivers described in this section provide Ethernet at 1 gigabit per second (Gbps).

The Avaya VSP 8200 supports SFP transceivers on ports 1/1-1/40 and 2/1-2/40 .

The Avaya VSP 8400 ports can be used with SFP transceivers depending on the type of Ethernet Switch Modules (ESM) installed. For information on ESM types, see, *Installing the Avaya Virtual Services Platform 8000 Series*, NN47227-300.

The Avaya VSP 7200 Series supports SFP transceivers on ports 1/1–1/48.

### Important:

The VSP 8000 and VSP 7200 Series operate in forgiving mode for SFP transceivers, which means that the switch will bring up the port operationally when using non-Avaya SFP transceivers. Avaya does not provide support for operational issues related to these SFP transceivers, but they will operate and the port link will come up. The switch logs the device as an unsupported or unknown device.

### Note:

Auto-negotiation is always disabled for 1 Gigabit Ethernet transceivers on VSP 7254XSQ, so for proper operation with a 1000BASE-T SFP, the remote 1000BASE-T interface must have auto-negotiation enabled. If not, the link will not be established. Also note that because the SFP+ ports on the VSP 7254XSQ only support 1 and 10 Gbps speeds, the AA1419043-E6 1000BASE-T SFP will only operate at 1G speeds.

---

## Selecting an SFP

Use an SFP transceiver to connect a device motherboard to a fiber optic or unshielded twisted pair network cable. Select the appropriate transceiver to provide the required reach.

### Procedure

1. Determine the required reach.

Depending on the product, SFP transceivers are available for cable distances of up to 100 meters (m), 550 m, 10 kilometers (km), 40 km, 70 km, and 120 km.

2. Determine the required media and connector type.

You need fiber optic cable for a reach over 100 m.

Possible media include CAT5, single mode fiber, and multimode fiber. Possible connectors include LC, MT-RJ, and RJ-45.

3. If the media is optical fiber, determine wavelength restrictions or requirements.

To expand available bandwidth on a common optical fiber, use Coarse Wavelength Division Multiplexing (CWDM) SFP transceivers.

4. Determine if you need digital diagnostic monitoring (DDM). DDM is enabled by default.

Not all SFP transceivers or products support DDM.

### Job aid

SFP transceivers are hot-swappable input and output interface devices designed for use with Avaya products to allow gigabit Ethernet ports to link with other gigabit Ethernet ports over various media types.

The system also supports CWDM SFP transceivers. CWDM technology consolidates multiple optical channels on a common optical fiber. CWDM uses multiple wavelengths to expand available bandwidth.

CWDM SFP transceivers support high speed data communications for Metropolitan Area Networks (MAN). The system uses a grid of eight CWDM optical wavelengths in both ring and point-to-point configurations. All components are color-coded by wavelength.

#### Important:

The attainable cable length can vary depending on the quality of the fiber optic cable used.

The following table describes the SFP transceivers including the reach provided by various SFP transceivers. This table is informational only—not all Avaya Ethernet switching and routing products support all the SFP transceivers listed here.

**Table 1: Compatible 1000BASE SFP transceivers**

Model	Description	Minimum software version			Part number
		VSP 7200	VSP 8200	VSP 8400	
<p><b>! Important:</b>            Avaya supports SFP transceivers with the following part numbers: AA1419013-E5, AA1419014-E5, AA1419015-E5, and AA1419025-E5 to AA1419040-E5. However, Avaya strongly recommends using the newer DDI versions of these SFP transceivers.</p>					
1000BASE-SX SFP	850 nm LC connector	4.2.1	4.0.0	4.2.0	AA1419013-E5*
1000BASE-SX SFP	LC Digital Diagnostic Monitoring Interface	4.2.1	4.0.0	4.2.0	AA1419014-E5*
1000BASE-LX SFP	1310 nm LC connector	4.2.1	4.0.0	4.2.0	AA1419015-E5*
1000BASE-XD CWDM SFP	From 1470 nm to 1610 nm LC connector, up to 40 km	4.2.1	4.0.0	4.2.0	AA1419025-E5 to AA1419032-E5
1000BASE-ZX CWDM SFP	From 1470 nm to 1610 nm LC connector, up to 70 km	4.2.1	4.0.0	4.2.0	AA1419033-E5 to AA1419040-E5
1000BASE-T SFP	gigabit Ethernet, RJ-45 connector	4.2.1	4.0.0	4.2.0	AA1419043-E6
1000BASE-SX DDI SFP	850 nm, gigabit Ethernet, duplex LC connector	4.2.1	4.0.0	4.2.0	AA1419048-E6
1000BASE-LX DDI SFP	1310 nm, gigabit Ethernet, duplex LC connector	4.2.1	4.0.0	4.2.0	AA1419049-E6
1000BASE-XD DDI SFP	1310 nm, gigabit Ethernet, duplex LC connector	4.2.1	4.0.0	4.2.0	AA1419050-E6*
	1550 nm, gigabit Ethernet, duplex LC connector	4.2.1	4.0.0	4.2.0	AA1419051-E6*
1000BASE-ZX DDI SFP	1550 nm, gigabit Ethernet, duplex LC connector	4.2.1	4.0.0	4.2.0	AA1419052-E6*
1000BASE-XD DDI CWDM 40 km SFP	gigabit Ethernet, duplex LC connector	4.2.1	4.0.0	4.2.0	AA1419053-E6 to AA1419060-E6*

*Table continues...*

Model	Description	Minimum software version			Part number
		VSP 7200	VSP 8200	VSP 8400	
1000BASE-ZX DDI CWDM 70 km SFP	gigabit Ethernet, duplex LC connector	4.2.1	4.0.0	4.2.0	AA1419061- E6 to AA1419068- E6*
1000BASE-BX10 DDI SFP	1310 nm (tx) and 1490 nm (rx)  gigabit Ethernet, single- fiber LC connector	4.2.1	4.0.0	4.2.0	AA1419069- E6 (10 km at 1310 nm ) and mating pair AA1419070- E6 (10 km at 1490 nm)
1000BASE-EX DDI SFP	1550 nm, gigabit Ethernet, duplex LC connector	4.2.1	4.0.0	4.2.0	AA1419071- E6*
1000BASE-BX10 DDI SFP	1490 nm (tx) 1310 nm (rx)  gigabit Ethernet, single- fiber LC connector	4.2.1	4.0.0	4.2.0	AA1419076- E6 (40 km at 1310 nm) and mating pair AA1419077- E6 (40 km at 1490 nm)

**!** **Important:**

Avaya recommends the use of Avaya branded SFP transceivers as they have been through extensive qualification and testing. Avaya will not be responsible for issues related to non-Avaya branded SFP transceivers.

For more information about SFP specifications, see [SFP specifications](#) on page 25.

## Installing an SFP

Install an SFP to provide an interface between the device and the network cable.

### Before you begin

- Verify that the SFP is the correct model for your network configuration.
- Before you install the optical connector, ensure it is clean.

**!** **Danger:**

**Risk of eye injury by laser**

Fiber optic equipment can emit laser or infrared light that can injure your eyes. Never look into an optical fiber or connector port. Always assume that fiber optic cables connect to a light source.

 **Electrostatic alert:**

ESD can damage electronic circuits. Do not touch electronic hardware unless you wear a grounding wrist strap or other static-dissipating device.

 **Warning:**

**Risk of equipment damage**

Only trained personnel can install this product.

**About this task**

Installing an SFP takes approximately 3 minutes.

**Procedure**

1. Remove the SFP from its protective packaging.
2. Grasp the SFP transceiver between your thumb and forefinger.
3. Insert the device into the port on the module.

Depending on the module type, you must insert some SFP transceivers into the port with the bail facing up and some SFP transceivers with the bail facing down.

 **Warning:**

**Risk of equipment damage**

SFP transceivers are keyed to prevent incorrect insertion. If the SFP transceiver resists pressure, do not force it; turn it over, and reinsert it.

Apply a light pressure to the device until it clicks and locks into position.

4. Remove the dust cover from the optical bore, and insert the fiber optic connector.

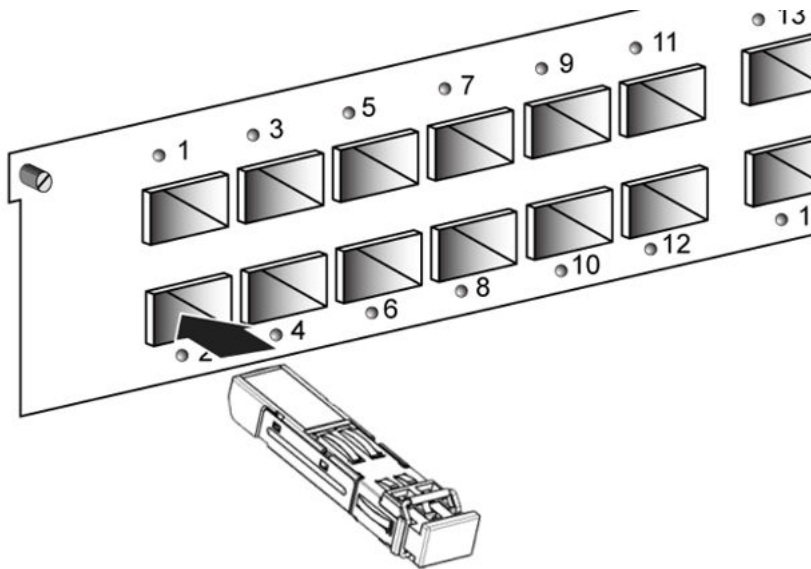
**Example****Job aid**

Depending on the transceiver manufacturer, the SFP transceiver can use different types of locking and extractor mechanisms.

The following figure shows the typical mechanism used on SFP transceivers; other locking mechanisms exist although they are not shown here. In the following figure, the SFP transceiver uses the bore plug. Pull the bail to release the device.

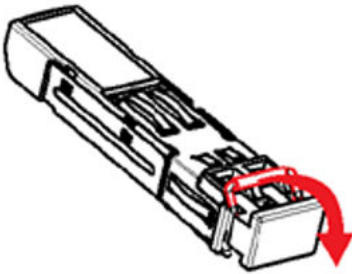
**Removing an SFP**

Remove an SFP to replace it or to commission it elsewhere.

**Before you begin**

- Wear an antistatic wrist strap.

**⚠ Danger:**

**Risk of eye injury by laser**



Fiber optic equipment can emit laser or infrared light that can injure your eyes. Never look into an optical fiber or connector port. Always assume that fiber optic cables connect to a light source.

 **Electrostatic alert:**

ESD can damage electronic circuits. Do not touch electronic hardware unless you wear a grounding wrist strap or other static-dissipating device.

### Procedure

1. Disconnect the network fiber optic cable from the SFP connector.
2. Depending on your SFP model, there are different locking mechanisms to release the SFP transceiver. The following describes the typical mechanism used on SFP transceivers; other locking and extractor mechanisms exist, although they are not described here.
  - Bail latch: Pull the swing-down latch handle to the fully lowered position and hold the handle to extract the module.
3. Slide the SFP out of the module SFP slot.

If the SFP does not slide easily from the module slot, use a gentle side-to-side rocking motion while firmly pulling the SFP from the slot.

4. Affix dust covers over the fiber optic bore and connector.
5. Store the SFP in a safe place until needed.

 **Important:**

If you discard the SFP transceiver, dispose of it according to all national laws and regulations.

---

## SFP specifications

This section provides technical specifications for the supported Small Form Factor Pluggable (SFP) models. Use this information to aid in proper network design.

The specifications in this section meet or exceed those specified in the applicable IEEE standards, where they exist.

In these specifications, unless otherwise noted, receiver sensitivity is the minimum average input optical power for which the receiver is guaranteed to meet the bit error rate (BER) of  $10^{-12}$ .

 **Important:**

The switch operates in forgiving mode for SFP transceivers, which means that the switch will bring up the port operationally when using non-Avaya SFP transceivers. Avaya does not provide support for operational issues related to these SFP transceivers, but they will operate and the port link will come up. The switch logs the device as an unsupported or unknown device.

## SFP labels

The Avaya label on a typical SFP transceiver contains an Avaya serial number, a bar code, a manufacturer code, an interface type, and a part number.

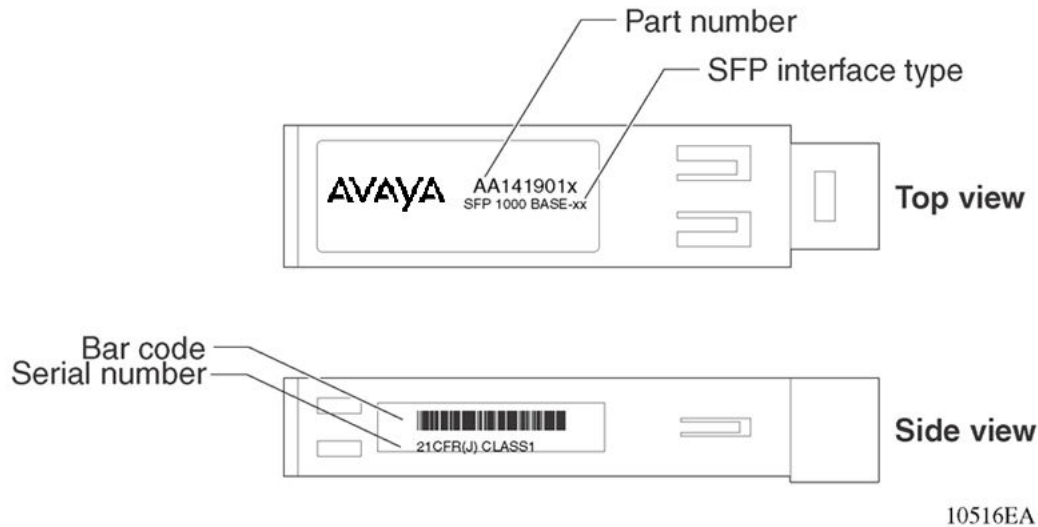

Figure 1: SFP label

## General SFP specifications

The following table describes general SFP specifications.

Table 2: General SFP specifications

Parameter	Description
Dimensions (H x W x D)	8.5 x 13.4 x 56.4 millimeters (0.33 x 0.53 x 2.22 inches), unless otherwise stated.
Operating temperature	-5 to 85 °C for RoHS -E6 models
Storage temperature	-40 to 85 °C
Maximum supply current	300 mA, unless otherwise stated
Maximum power consumption	1.0 W, unless otherwise stated

## Supported SFP transceivers

The following section provides specifications for the supported SFP transceivers.

## Autonegotiation

Use Autonegotiation to allow the device to automatically negotiate the best common data rate and duplex mode to use between two Autonegotiation-capable Ethernet devices.

## 1000BASE-SX (LC) SFP specifications

The 1000BASE-SX SFP transceiver provides 1000BASE-SX gigabit Ethernet connectivity at 850 nm using multimode optical fiber. This SFP supports only full-duplex operation. The part number is AA1419013-E5.

The following table describes standards, connectors, cabling, and distance for the 1000BASE-SX SFP transceivers.

**Table 3: IEEE 802.3z 1000BASE-SX (LC) SFP specifications**

Parameter	Specifications
Connectors	Duplex LC
Cabling	<ul style="list-style-type: none"> <li>• 62.5 <math>\mu\text{m}</math> MMF optic cable</li> <li>• 50 <math>\mu\text{m}</math> MMF optic cable</li> </ul>
Distance	<ul style="list-style-type: none"> <li>• up to 275 m using 62.5 <math>\mu\text{m}</math> MMF optic cable</li> <li>• up to 550 m using 50 <math>\mu\text{m}</math> MMF optic cable</li> </ul>
Wavelength	850 nanometers (nm)
Link optical power budget	7.0 deciBels (dB)
<b>Transmitter characteristics</b>	
Launch power	-10 to -4.0 dBm
<b>Receiver characteristics</b>	
Receiver sensitivity	-17 dBm
Maximum input power	0 dBm

## 1000BASE-SX (MT-RJ) SFP specifications

The 1000BASE-SX (MT-RJ) type SFP provides gigabit Ethernet connectivity using MT-RJ multimode fiber connectors. The part number is AA1419014-E5.

The following table describes standards, connectors, cabling, and distance for the 1000BASE-SX (MT-RJ) type SFP transceiver.

**Table 4: IEEE 802.3z 1000BASE-SX (MT-RJ) SFP specifications**

Parameter	Specifications
Connectors	Duplex MT-RJ
Cabling	<ul style="list-style-type: none"> <li>• 62.5 <math>\mu\text{m}</math> MMF optic cable</li> <li>• 50 <math>\mu\text{m}</math> MMF optic cable</li> </ul>

*Table continues...*

Parameter	Specifications
Distance	<ul style="list-style-type: none"> <li>• up to 275 m using 62.5 µm MMF optic cable</li> <li>• up to 550 m using 50 µm MMF optic cable</li> </ul>
Wavelength	850 nm
Link optical power budget	7.0 dB
<b>Transmitter characteristics</b>	
Launch power	-10 to -4.0 dBm
<b>Receiver characteristics</b>	
Receiver sensitivity	-17 dBm
Maximum input power	0 dBm

## 1000BASE-LX SFP specifications

The 1000BASE-LX SFP transceiver provides 1000BASE-LX gigabit Ethernet connectivity at 1310 nanometers (nm) using single mode or multimode optical fiber. The 1000BASE-LX SFP transceiver supports only full-duplex operation. The part number is AA1419015-E5.

The following table describes standards, connectors, cabling, and distance for the 1000BASE-LX SFP transceiver.

**Table 5: IEEE 802.3z 1000BASE-LX SFP specifications**

Parameter	Specifications
Connectors	Duplex LC
Cabling	<ul style="list-style-type: none"> <li>• 50 micrometer (µm) multimode fiber (MMF)</li> <li>• 62.5 µm multimode fiber</li> <li>• 9 µm single mode fiber (SMF)</li> </ul>
Distance	<ul style="list-style-type: none"> <li>• Up to 550 meters (m) using MMF</li> <li>• Up to 10 kilometers (km) using SMF</li> </ul>
Wavelength	1310 nm
Link optical power budget	10.5 dB
<b>Transmitter characteristics</b>	
Launch power	-9.5 to -3.0 dBm
<b>Receiver characteristics</b>	
Receiver sensitivity	-20 dBm
Maximum input power	-3.0 dBm

## 1000BASE-XD CWDM SFP specifications

The 1000BASE-XD SFP transceiver provides CWDM gigabit Ethernet connectivity using single mode fiber. This SFP transceiver supports only full-duplex operation. The part numbers of the 40 km models range from AA1419025-E5 to AA1419032-E5.

**! Important:**

For the 40 km CWDM SFP transceiver, a minimum attenuation of 4 dB must be present between the transmitter and receiver. To avoid receiver saturation, you must insert a minimum attenuation of 4 dB when you test the CWDM SFP transceiver in loopback mode, or use short runs of fiber with no intermediate CWDM OADM or CWDM OMUX.

**Table 6: 1000BASE-XD CWDM (40 km) SFP specifications**

Parameter	Specifications
Connectors	Duplex LC
Cabling	SMF, 9 $\mu$ m
Data rate	1.0 Gbps
Line rate (8B/10B code)	1.25 Gbps
Operating temperature range	0 to 60C
Link optical power budget	17 dB
<b>Transmitter characteristics</b>	
Launch power	-4.0 to 1.0 dBm
<b>Receiver characteristics</b>	
Receiver sensitivity	-21 dBm
Maximum input power	-3.0 dBm

**1000BASE-ZX CWDM (LC) SFP specifications**

The 1000BASE-ZX SFP transceiver provides CWDM gigabit Ethernet connectivity using single mode fiber. This SFP supports only full-duplex operation. The part numbers of the 70 km models range from AA1419033-E5 to AA1419040-E5.

**! Important:**

For the 70 km CWDM SFP transceivers, a minimum attenuation of 10 dB must be present between the transmitter and receiver.

**Table 7: 1000BASE-ZX CWDM (70 km) SFP specifications**

Parameter	Specifications
Connectors	Duplex LC
Cabling	SMF, 9 $\mu$ m
Data rate	1.0 Gbps
Line rate (8B/10B code)	1.25 Gbps
Operating temperature range	0 to 60°C
Link optical power budget	20 dB
<b>Transmitter characteristics</b>	

*Table continues...*

Parameter	Specifications
Launch power	-3.0 to 2.0 dBm
<b>Receiver characteristics</b>	
Receiver sensitivity	-23 dBm
Maximum input power	-3.0 dBm

## 1000BASE-T SFP specifications

The 1000BASE-T SFP provides gigabit Ethernet connectivity using a single eight-pin RJ-45 connector. The 1000BASE-T SFP only operates at 1 gigabits per second (Gbps) and does not support 100BASE-T SFP or 10BASE-T interfaces. The part number for this model is AA1419043-E6.

### Important:

You must disable autonegotiation before you use the 1000BASE-T SFP because the default setting on most modules is autonegotiation enabled.

The maximum current requirement of the SFP is 375 milliamperes (mA) at 5 volts (V).

The following table describes the 1000BASE-T SFP specifications.

**Table 8: IEEE 802.3z 1000BASE-T SFP specifications**

Parameter	Specifications
Standards	IEEE 802.3z, IEEE 802.3ab
Connectors	RJ-45
Cabling	CAT5E or better UTP
Distance	Up to 100 m

## 1000BASE-SX DDI SFP specifications

The 1000BASE-SX DDI SFP transceiver has a reach of up to 550 m using 50  $\mu$ m MMF, and of 275 m using 62.5  $\mu$ m MMF. This SFP transceiver operates at 850 nm. The part number is AA1419048-E6.

The following table describes standards, connectors, cabling, and distance for the 1000BASE-SX DDI SFP transceivers.

**Table 9: 1000BASE-SX SFP DDI (550 m) specifications**

Parameter	Specifications
Maximum electrical power consumption	1 watt (W)
Connector	Duplex LC
Cabling	MMF
Data rate	1.0 Gbps

*Table continues...*

Parameter	Specifications
Line rate (8B/10B code)	1.25 Gbps
Link optical power budget	7.5 dB
<b>Transmitter characteristics</b>	
Launch power	-9.5 to -4.0 dBm
<b>Receiver characteristics</b>	
Receiver sensitivity	-17 dBm
Maximum receiver power	0 dBm

## 1000BASE-LX DDI SFP specifications

This SFP transceiver provides 1000BASE-LX gigabit Ethernet connectivity at 1310 nanometers (nm) using single mode or multimode optical fiber. The part number is AA1419049-E6.

**Table 10: 1000BASE-LX DDI SFP specifications**

Parameter	Specifications
Maximum electrical power consumption	1.0 watt (W)
Connectors	Duplex LC
Cabling	<ul style="list-style-type: none"> <li>• 50 micrometer (<math>\mu\text{m}</math>) multimode fiber (MMF)</li> <li>• 62.5 <math>\mu\text{m}</math> multimode fiber</li> <li>• 9 <math>\mu\text{m}</math> single mode fiber (SMF)</li> </ul>
Distance	<ul style="list-style-type: none"> <li>• Up to 550 meters (m) using MMF</li> <li>• Up to 10 kilometers (km) using SMF</li> </ul>
Data rate	1.0 Gbps
Line rate (8B/10B code)	1.25 Gbps
Link optical power budget	9.5 dB
<b>Transmitter characteristics</b>	
Launch power	-9.5 to -3.0 dBm
<b>Receiver characteristics</b>	
Receiver sensitivity	-19.0 dBm
Maximum receiver power	-3.0 dBm

## 1000BASE-XD DDI 1310 nm SFP specifications

The following table describes the 1000BASE-XD DDI SFP. This SFP operates at 1310 nm and has a reach of up to 40 km. The part number is AA1419050-E6.

**Table 11: 1000BASE-XD DDI 1310 nm SFP specifications**

Parameter	Specifications
Maximum electrical power consumption	1.0 W
Connectors	Duplex LC
Cabling	SMF, 9 $\mu$ m
Data rate	1.0 Gbps
Line rate (8B/10B) code	1.25 Gbps
Link optical power budget	18 dB
<b>Transmitter characteristics</b>	
Launch power	-4.5 to 0 dBm
<b>Receiver characteristics</b>	
Receiver sensitivity	-22.5 dBm
Maximum receiver power	0 dBm

## 1000BASE-XD DDI 1550 nm SFP specifications

The following table describes the 1000BASE-XD DDI SFP transceiver. This SFP transceiver operates at 1550 nm and has a reach of up to 40 km. The part number is AA1419051-E6.

This transceiver has been discontinued and is no longer available for purchase. Avaya recommends AA1419057-E6 as a replacement.

### **Warning:**

#### **Risk of equipment damage**

To prevent damage to the optical receiver, ensure that at least 3 dB of attenuation exists between the transmit and receive ports.

**Table 12: 1000BASE-XD DDI 1550 nm SFP transceiver specifications**

Parameter	Specification
Maximum electrical power consumption	1.0 W
Connectors	Duplex LC
Cabling	SMF, 9 $\mu$ m
Data rate	1.0 Gbps
Line rate (8B/10B code)	1.25 Gbps
Link optical power budget	22 dB
Maximum dispersion power penalty	2 dB at 40 km
Minimum attenuation between transmit and receive ports	3 dB
<b>Transmitter characteristics</b>	

*Table continues...*



Parameter	Specification
Launch power	-2.0 to 3.0 dBm
<b>Receiver characteristics</b>	
Receiver sensitivity	-24 dBm
Maximum receiver power	0 dBm

## 1000BASE-ZX DDI 1550 nm SFP specifications

The following table describes the 1000BASE-ZX CWDM SFP transceiver. This SFP transceiver operates at 1550 nm and has a reach of up to 70 km. The part number is AA1419052-E6.

This transceiver has been discontinued and is no longer available for purchase. Avaya recommends AA1419065-E6 as a replacement.

### Warning:

#### Risk of equipment damage

To prevent damage to the optical receiver, ensure that at least 5 dB of attenuation exists between the transmit and receive ports.

**Table 13: 1000BASE-ZX DDI 1550 nm SFP transceiver specifications**

Parameter	Specification
Maximum electrical power consumption	1.0 W
Connectors	Duplex LC
Cabling	SMF, 9 $\mu$ m
Data rate	1.0 Gbps
Line rate (8B/10B code)	1.25 Gbps
Link optical power budget	24 dB
Maximum dispersion power penalty	2 dB at 70 km
Minimum attenuation between transmit and receive ports	5 dB
<b>Transmitter characteristics</b>	
Launch power	0 to 5 dBm
<b>Receiver characteristics</b>	
Receiver sensitivity	-24 dBm
Maximum receiver power	-0 dBm

## 1000BASE-XD DDI CWDM (40 km) SFP specifications

The following table describes specifications for 1000BASE-XD DDI CWDM SFP transceivers numbered AA1419053-E6 to AA1419060-E6.

**Warning:****Risk of equipment damage**

To prevent damage to the optical receiver, ensure that at least 4 dB of attenuation exists between the transmit and receive ports.

**Table 14: 1000BASE-XD CWDM SFP DDI (40 km) specifications**

Parameter	Specifications
Maximum electrical power consumption	1.0 W
Connectors	Duplex LC
Cabling	SMF, 9 µm
Data rate	1 Gbps
Line rate (8B/10B code)	1.25 Gbps
Link optical power budget	17 dB
Maximum dispersion power penalty	1 dB at 40 km
<b>Transmitter characteristics</b>	
Launch power	-4.0 to 1.0 dBm
<b>Receiver characteristics</b>	
Receiver sensitivity	-21 dBm
Maximum receiver power	-3.0 dBm

**1000BASE-ZX DDI CWDM 70 km SFP specifications**

The following table describes specifications for CWDM SFP transceivers numbered AA1419061-E6 to AA1419068-E6.

**Warning:****Risk of equipment damage**

To prevent damage to the optical receiver, ensure that at least 8 dB of attenuation is present between the transmit and receive ports.

**Table 15: 1000BASE-ZX CWDM SFP (70 km) specifications**

Parameter	Specifications
Maximum electrical power consumption	1.0 W
Connectors	Duplex LC
Cabling	SMF, 9 µm
Data rate	1.0 Gbps
Line rate (8B/10B code)	1.25 Gbps
Link optical power budget	24 dB

*Table continues...*

Parameter	Specifications
Maximum dispersion power penalty	2 dB at 70 km
<b>Transmitter characteristics</b>	
Launch power	0 to 5.0 dBm
<b>Receiver characteristics</b>	
Receiver sensitivity	-24 dBm
Maximum receiver power	-3.0 dBm

## 1000BASE-BX bidirectional SFP transceivers

The 1000BASE-BX bidirectional DDI SFP transceivers provides gigabit Ethernet connectivity over a single fiber.

### Warning:

#### Risk of equipment damage

For the 40 km transceivers only. Connect the 1000BASE-BX SFP transceiver using a single mode fiber with at least 6 dB of attenuation. Damage can result if insufficient attenuation is provided or if the same 1000BASE-BX SFP transceivers are connected.

In the following figure, the transmit (Tx) and receive (Rx) paths share the same fiber by using two different wavelengths. One model transmits at 1310 nm and receives at 1490 nm, while the mating model transmits at 1490 nm and receives at 1310 nm. You can only connect a mating pair.

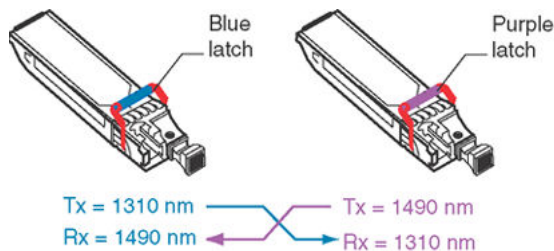

The long wavelength optical transceivers used in these models provide variable distance ranges using single mode fiber optic cabling.

You can use 1000BASE-BX SFP transceivers to double the number of your fiber links. For example, if you install 20 fiber pairs with 20 conventional ports connected, you can use 1000BASE-BX SFP transceivers to expand to 40 ports, using the same fiber.

The following table provides the reach and part numbers for each of the mating pairs.

**Table 16: 1000BASE-BX SFP transceivers**

Reach	1310 nm	1490 nm
10 km	AA1419069-E6	AA1419070-E6
40 km	AA1419076-E6	AA1419077-E6

### 1000BASE-BX10 bidirectional DDI SFP specifications

The 1000BASE-BX10 SFP transceivers (part numbers AA1419069-E6 and AA1419070-E6) can attain a reach of up to 10 km.

The following table describes standards, connectors, cabling, and distances for the 1000BASE-BX10 SFP transceiver.

**Table 17: IEEE 802.3ah 1000BASE-BX10 bidirectional SFP specifications**

Parameter	Specification
Connectors	Single-fiber LC
Data rate	1.0 Gbps
Line rate (8B/10B code)	1.25 Gbps
Distance	Up to 10 km
Wavelength	1310 nm and 1490 nm
Link optical power budget	11.0 dB
Maximum transmitter and dispersion power penalty	3.3 dB
<b>Transmitter characteristics</b>	
Maximum launch power	-3.0 dBm
Minimum launch power	-9.0 dBm
<b>Receiver characteristics</b>	
Maximum receiver sensitivity	-19.5 dBm
Maximum input power (maximum average receive power)	-3.0 dBm

### 1000BASE-BX40 bidirectional SFP specifications

The 1000BASE-BX40 SFP transceivers (part numbers AA1419076-E6 and AA1419077-E6) can attain a reach of up to 40 km. The minimum IL is 6 dB.

The following table describes standards, connectors, cabling, and distances for the 1000BASE-BX40 SFP transceiver.

**Table 18: 1000BASE-BX40 bidirectional SFP specifications**

Parameter	Specifications
Connectors	Single-fiber LC
Data rate	1.0 Gbps
Line rate (8B/10B code)	1.25 Gbps
Distance	Up to 40 km with SMF
Wavelength	1310 nm and 1490 nm
Link optical power budget	20.0 dB

*Table continues...*

Parameter	Specifications
Maximum transmitter and dispersion power penalty	3.3 dB
<b>Transmitter characteristics</b>	
Maximum launch power	3.0 dBm
Minimum launch power	-3.0 dBm
<b>Receiver characteristics</b>	
Maximum receiver sensitivity	-23 dBm
Maximum input power (maximum average receive power)	-3.0 dBm

## 1000BASE-EX DDI SFP specifications

The following table describes the 1000BASE-EX DDI SFP transceiver. This SFP transceiver operates at 1550 nm and has a reach of up to 120 km. The part number is AA1419071-E6.

### Warning:

#### Risk of equipment damage

To prevent damage to the optical receiver, ensure that at least 14 dB of attenuation exists between the transmit and receive ports.

To attain the BER of  $10^{-12}$ , the minimum attenuation between the transmit and receive ports is 15 dB.

**Table 19: 1000BASE-EX DDI SFP transceiver specifications**

Parameter	Specification
Maximum electrical power consumption	1.2 W
Connectors	Duplex LC
Cabling	SMF, 9 $\mu$ m
Data rate	1.0 Gbps
Line rate (8B/10B code)	1.25 Gbps
Link optical power budget	30 dB
Maximum dispersion power penalty	2.0 dB at 120 km
Minimum attenuation between transmit and receive ports	14 dB
<b>Transmitter characteristics</b>	
Launch power	0 to 5.0 dBm
<b>Receiver characteristics</b>	
Receiver sensitivity	-30 dBm
Maximum receiver power	-9.0 dBm

# Chapter 5: SFP+

This chapter provides installation procedures and specifications for Small Form Factor Pluggable plus (SFP+) transceivers.

---

## SFP+ transceivers

This section describes how to select and install Small Form Factor Pluggable plus (SFP+) transceivers.

Use an SFP+ transceiver to connect a device motherboard to fiber optic or direct attach cables, up to 15 meters in length. SFP+ transceivers are similar to SFP transceivers in physical appearance but SFP+ transceivers support 10-gigabit per second (Gbps) connections. SFP+ modules do not interoperate with SFP modules.

The Avaya VSP 8200 supports SFP+ transceivers on ports 1/1-1/40 and 2/1-2/40.

The Avaya VSP 8400 ports can be used with SFP+ transceivers depending on the type of Ethernet Switch Modules (ESM) installed. For information on ESM types, see *Installing the Avaya Virtual Services Platform 8000 Series*, NN47227-300.

The Avaya VSP 7200 Series supports SFP+ transceivers on ports 1/1–1/48.

### ! Important:

- The VSP 8000 and VSP 7200 Series operate in strict mode for SFP+ transceivers, which means that the switch will not bring the port up operationally when using non-Avaya SFP+ transceivers.
- The VSP 8000 and VSP 7200 Series operate in forgiving mode for SFP+ direct attach cables (DACs), which means that the switch will bring up the port operationally when using non-Avaya direct attach cables. Avaya does not provide support for operational issues related to these DACs, but they will operate and the port link will come up.

### \* Note:

Although VSP 8000 and VSP 7200 Series support 10G and 40G DAC cables in forgiving mode, the output to the command `show pluggable-optical-modules basic` displays the corresponding vendor names instead of leaving the vendor name blank as in the releases prior to VOSS 4.2.1.

## Selecting an SFP+

Use an SFP+ transceiver to interface a port to a fiber optic cable.

### About this task

Select the appropriate transceiver to provide the required reach. Depending on the product, you can obtain SFP+ transceivers for cable distances of up to 15 meters (m), 400 m, 10 kilometers (km), 40 km, and 70 km. Alternatively, you can use a direct attach cable (10GBASE-CX) to connect ports for cable distances of up to 15 meters.

### Procedure

1. Determine the required reach.
2. Determine wavelength restrictions or requirements.
3. Use the following job aid to determine the appropriate SFP+ transceiver or cable for your application.

### Job aid

SFP+ transceivers are hot-swappable input and output interface devices that allow 10-gigabit connections.

All Avaya SFP+ transceivers use LC connectors to provide precision keying and low interface losses.

The following table lists and describes the Avaya SFP+ models.

**Table 20: Compatible 10-gigabit SFP+ transceivers**

Hardware	Description	Minimum software version			Part number
		VSP 7200	VSP 8200	VSP 8400	
10GBASE-LR/LW SFP+	10 km, 1310 nm SMF	4.2.1	4.0.0	4.2.0	AA1403011-E6
10GBASE-ER/EW SFP+	40 km, 1550 nm SMF	4.2.1	4.0.0	4.2.0	AA1403013-E6
10GBASE-SR/SW SFP+	400 m, 850 nm MMF	4.2.1	4.0.0	4.2.0	AA1403015-E6
10GBASE-ZR/ZW SFP+	70 km, 1550 nm SMF	VSP 7254XSQ has a PHYless design which is typical for Data Center Top of Rack switches. The benefits of a	4.0.0	4.2.0	AA1403016-E6

*Table continues...*

Hardware	Description	Minimum software version			Part number
		VSP 7200	VSP 8200	VSP 8400	
		<p>PHYless design are lower power consumption and lower latency. However, due to the PHYless design, this transceiver is not supported.</p> <p>Substitute with 10GBASE-ZR CWDM DDI SFP+ (AA1403165-E6)</p>			
10GBASE-LRM SFP+	220 m, 1260 to 1355 nm; 1310 nm nominal MMF	<p>VSP 7254XSQ has a PHYless design which is typical for Data Center Top of Rack switches. The benefits of a PHYless design are lower power consumption and lower latency. However, due to the PHYless design, this transceiver is not supported.</p>	4.0.0	4.2.0	AA1403017-E6
10GBASE-CX SFP+ 2-pair twinaxial copper cable that plugs into the SFP+ socket and	10 meter	4.2.1	4.0.0	4.2.0	AA1403018-E6

*Table continues...*



Hardware	Description	Minimum software version			Part number
		VSP 7200	VSP 8200	VSP 8400	
connects two 10-gigabit ports					
10GBASE-ER CWDM DDI SFP+	40 km, 1471 to 1611 nm	4.2.1	4.0.0	4.2.0	AA1403153-E6 to AA1403160-E6
10GBASE-ZR CWDM DDI SFP+	70 km, 1471 to 1611 nm	4.2.1	4.0.0	4.2.0	AA1403161-E6 to AA1403168-E6
10GBASE-LR/LW SFP+	10 km, 1310 nm SMF	4.2.1	4.1.0	4.2.0	AA1403011-E6
10GBASE-BX10 SFP+	10 km	4.2.1	4.2.1	4.2.1	AA1403169-E6 and AA1403170-E6

**! Important:**

Avaya recommends the use of Avaya branded SFP+ transceivers as they have been through extensive qualification and testing. Avaya will not be responsible for issues related to non-Avaya branded SFP+ transceivers.

For more information about SFP+ specifications, see [SFP+ specifications](#) on page 44.

## Installing an SFP+

Install an SFP+ transceiver to provide a 10-gigabit Ethernet interface between the device and other network devices.

### Before you begin

**! Important:**

Do not install an SFP+ transceiver in an SFP slot. The two transceivers look the same but function differently. Ensure the slot is an SFP+ slot.

- Verify that the SFP+ transceiver is the correct model for your network configuration.
- Before you install the optical connector, ensure it is clean.

**! Danger:**

#### Risk of eye injury by laser

Fiber optic equipment can emit laser or infrared light that can injure your eyes. Never look into an optical fiber or connector port. Always assume that fiber optic cables connect to a light source.

 **Electrostatic alert:**

ESD can damage electronic circuits. Do not touch electronic hardware unless you wear a grounding wrist strap or other static-dissipating device.

 **Warning:**

**Risk of equipment damage**

Only trained personnel can install this product.

**About this task**

Installing an SFP+ transceiver takes approximately 3 minutes.

**Procedure**

1. Remove the SFP+ transceiver from its protective packaging.
2. Grasp the SFP+ transceiver between your thumb and forefinger.
3. Insert the device into the port on the module.

Depending on the module type, you must insert some SFP+ transceivers into the port with the bail facing up and some SFP+ transceivers with the bail facing down.

 **Warning:**

**Risk of equipment damage**

SFP+ transceivers are keyed to prevent incorrect insertion. If the SFP+ transceiver resists pressure, do not force it; turn it over, and reinsert it.

Apply a light pressure to the SFP+ transceiver until the device clicks and locks into position in the module.

4. Remove the dust cover from the SFP+ optical bores, and insert the fiber optic cable.

## Example

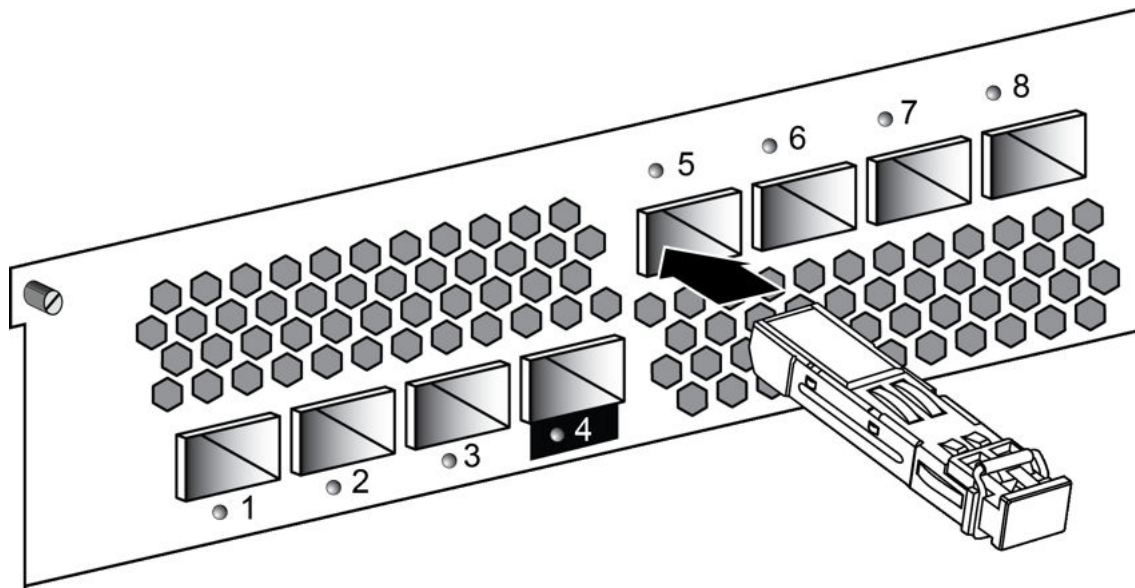

## Job aid

Depending on the transceiver manufacturer, the SFP+ transceiver uses bail-latch type of locking and extractor mechanism.

The following figure shows typical mechanism used on SFP+ transceivers; other locking and extractor mechanisms exist. SFP+ transceivers are similar to SFP transceivers in physical appearance. In the following figure, the SFP+ transceiver still contains the bore plug. Pull the bail to release the device.

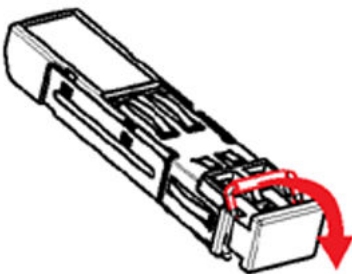

---

## Removing an SFP+

Remove an SFP+ transceiver to replace it or to commission it elsewhere.

### Before you begin

- Wear an antistatic wrist strap.

** Danger:****Risk of eye injury by laser**

Fiber optic equipment can emit laser or infrared light that can injure your eyes. Never look into an optical fiber or connector port. Always assume that fiber optic cables connect to a light source.

** Electrostatic alert:**

ESD can damage electronic circuits. Do not touch electronic hardware unless you wear a grounding wrist strap or other static-dissipating device.

**Procedure**

1. Disconnect the network fiber optic cable from the SFP+ connector.
2. Pull the swing-down latch handle to the fully lowered position, and hold the handle to extract the module.
3. Slide the SFP+ transceiver out of the module SFP+ slot.

If the SFP+ does not slide easily from the module slot, use a gentle side-to-side rocking motion while firmly pulling the SFP+ transceiver from the slot.

4. Affix dust covers over the fiber optic bore and connector.
5. Store the SFP+ transceiver in a safe place until needed.

** Important:**

If you discard the SFP+ transceiver, dispose of it according to all national laws and regulations.

---

## SFP+ specifications

This section provides technical specifications for the supported 10 gigabit SFP+ models. Use these specifications to aid in network design.

The specifications in this section are a subset of the IEEE 802.3ae, 802.3aq, and 802.3ak specifications. For more information, see these standards documents. All Avaya SFP+ transceivers meet or exceed these standards.

All Avaya SFP+ transceivers support Digital Diagnostic Monitoring (DDM).

** Important:**

- The VSP 8000 and VSP 7200 Series operate in strict mode for SFP+ transceivers, which means that the switch will not bring the port up operationally when using non-Avaya SFP+ transceivers.
- The VSP 8000 and VSP 7200 Series operate in forgiving mode for SFP+ direct attach cables, which means that the switch will bring up the port operationally when using non-

Avaya direct attach cables. Avaya does not provide support for operational issues related to these DACs, but they will operate and the port link will come up.

## SFP+ labels

The typical Avaya SFP+ transceiver has a label on the top and bottom or side of the transceiver. The following figures show example labels. Avaya does use alternate labels, depending on the size of the device and space available for label information. Some devices do not have a CLEI code or label.

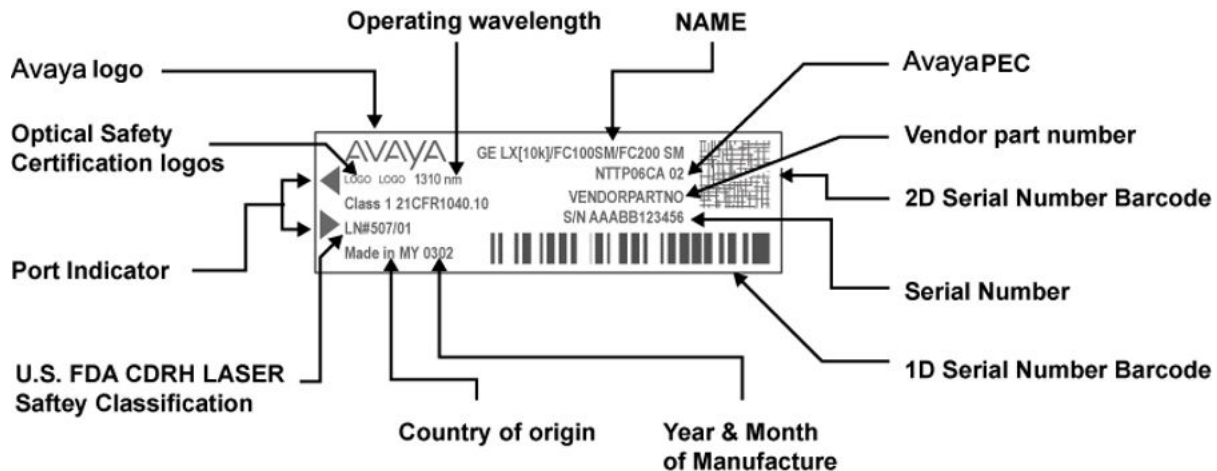

Figure 2: SFP+ top label



Figure 3: SFP+ bottom label

## General SFP+ specifications

The following table describes general SFP+ specifications.

Table 21: General SFP+ specifications

Parameter	Specifications
Dimensions (H x W x D)	8.5 x 13.4 x 56.4 millimeters (0.33 x 0.53 x 2.22 inches), unless otherwise stated.
Connectors	LC ultra physical contact (UPC)

Table continues...

Parameter	Specifications
Storage temperature	–40 to 85 °C
Operating temperature	0 to 70 °C for RoHS -E6 models up to 85 °C for high temperature models

## Supported SFP+ transceivers

The following section provides specifications for the supported SFP+ transceivers.

### 10GBASE-LR/LW SFP+ specifications

The 10GBASE-LR/LW SFP+ transceiver provides 10 GbE or OC-192 service at a nominal wavelength of 1310 nm. This SFP+ transceiver can attain link lengths of up to 10 km.

For more information about the 10GBASE-LR/LW SFP+ transceiver, including test and measurement information, see the IEEE 802.3ae standard.

The following table lists the transmitter and receiver specifications for the 10GBASE-LR/LW SFP+ transceiver. The part number of this SFP+ transceiver is AA1403011-E6.

**Table 22: IEEE 802.3ae 10GBASE-LR/LW SFP+ transceiver specifications**

Parameter	Specifications
Center wavelength range	1260 to 1355 nm; 1310 nm nominal
Distance	Up to 10 km
Link optical power budget	9.4 dB
Maximum transmitter and dispersion penalty	3.2 dB at 10 km
<b>Transmitter characteristics</b>	
Line rate (nominal)	10GBASE-LR 10.3125 Gbps ±100 ppm (10 GbE)
Average launch power	–8.2 to 0.5 dBm
Minimum launch power in OMA minus transmission and dispersion penalty (TDP)	–6.2 dBm
Minimum optical modulation amplitude	–5.2 dBm
Minimum extinction ratio	3.5 dB
Maximum optical return loss tolerance	–12 dB
Maximum transmitter reflectance	–12 dB
<b>Receiver characteristics</b>	
Line rate (nominal)	10GBASE-LR 10.3125 Gbps ± 100 ppm (10 GbE)
Average receive power for BER 10 <sup>-12</sup>	–14.4 dBm to 0.5 dBm
Receiver damage threshold	1.5 dBm
Maximum receiver sensitivity in OMA	–12.6 dBm

*Table continues...*

Parameter	Specifications
Maximum receiver reflectance	-12 dB
Stressed receiver sensitivity in OMA	-10.3 dBm

Examples of an OFF transmitter are as follows: no power supplied to the PDM, laser shutdown for safety conditions, activation of a PMD\_global\_transmit\_disable or other optional transmitter shutdown condition.

## 10GBASE-LR/LW SFP+ high temperature (-5 °C to +85 °C) specifications

The 10GBASE-LR/LW SFP+ high temperature transceiver (-5 °C to +85 °C) provides 10 GbE or OC-192 service at a nominal wavelength of 1310 nm. This SFP+ transceiver can attain link lengths of up to 10 km.

For more information about the 10GBASE-LR/LW SFP+ (-5 °C to +85 °C), including test and measurement information, see the IEEE 802.3ae standard.

The following table lists the transmitter and receiver specifications for the 10GBASE-LR/LW SFP+ transceiver (-5 °C to +85 °C). The part number of this SFP+ transceiver is AA1403011-E6HT.

**Table 23: IEEE 802.3ae 10GBASE-LR/LW SFP+ (-5 °C to +85 °C) transceiver specifications**

Parameter	Specifications
Center wavelength range	1260 to 1355 nm; 1310 nm nominal
Distance	Up to 10 km
Link optical power budget	9.4 dB
Maximum transmitter and dispersion penalty	3.2 dB at 10 km
Operating case temperature range	-5 °C to +85 °C
<b>Transmitter characteristics</b>	
Line rate (nominal)	10GBASE-LR 10.3125 Gbps ±100 ppm (10 GbE)
Average launch power	-8.2 to 0.5 dBm
Minimum launch power in OMA minus transmission and dispersion penalty (TDP)	-6.2 dBm
Minimum optical modulation amplitude	-5.2 dBm
Minimum extinction ratio	3.5 dB
Maximum optical return loss tolerance	-12 dB
Maximum transmitter reflectance	-12 dB
<b>Receiver characteristics</b>	
Line rate (nominal)	10GBASE-LR 10.3125 Gbps ± 100 ppm (10 GbE)
Average receive power for BER 10 <sup>-12</sup>	-14.4 dBm to 0.5 dBm
Maximum average receive power for damage	1.5 dBm
Maximum receiver sensitivity in OMA	-12.6 dBm

*Table continues...*

Parameter	Specifications
Maximum receiver reflectance	-12 dB
Stressed receiver sensitivity in OMA	-10.3 dBm

Examples of an OFF transmitter are as follows: no power supplied to the PDM, laser shutdown for safety conditions, activation of a PMD\_global\_transmit\_disable or other optional transmitter shutdown condition.

## 10GBASE-ER/EW SFP+ specifications

The 10GBASE-ER/EW SFP+ transceiver provides a reach of up to 40 km at a wavelength of 1550 nm.

For more information about the 10GBASE-ER/EW SFP+ transceiver, including test and measurement information, see the IEEE 802.3ae standard.

The following table lists the transmitter and receiver specifications for the 10GBASE-ER/EW SFP+ transceiver. The part number of this SFP+ transceiver is AA1403013-E6.

**Table 24: IEEE 802.3ae 10GBASE-ER/EW SFP+ transceiver specifications**

Parameter	Specifications
Line rate (nominal)	10GBASE-ER/EW 10.3125 Gb/s $\pm$ 100 ppm (10 GbE)
Center wavelength range	1530 to 1565 nm; nominal 1550 nm
Distance	Up to 40 km
Link optical power budget	15 dB
Transmitter and dispersion power penalty	3.0 dB at 40 km
<b>Transmitter characteristics</b>	
Launch power	-4.7 to 4.0 dBm
Minimum side mode suppression ratio	30 dB
Minimum launch power in OMA minus transmission and dispersion penalty (TDP)	-2.1 dBm
Minimum optical modulation amplitude	-1.7 dBm
Maximum average launch power of OFF transmitter	-30 dBm
Minimum extinction ratio	3.0 dB
Maximum RIN <sub>12</sub> OMA	-128 dB/Hz
Maximum optical return loss tolerance	-21 dB
<b>Receiver characteristics</b>	
Average receive power for BER 10 <sup>-12</sup>	- 15.8 dBm to -1.0 dBm
Maximum receive power for damage	4.0 dBm
Maximum receiver sensitivity in OMA	-14.1 dBm
Maximum receiver reflectance	-26 dB

*Table continues...*



Parameter	Specifications
Stressed receiver sensitivity in OMA	-11.3 dBm
Receive electrical 3 dB upper cutoff frequency (maximum)	12.3 GHz

The following list shows examples of an OFF transmitter:

- No power supplied to the PDM.
- Laser shutdown for safety conditions.
- Activation of `PMD_global_transmit_disable` or other optional transmitter shutdown condition.

## 10GBASE-SR/SW SFP+ specifications

The 10GBASE-SR/SW SFP+ transceivers provides 10 GbE service at 850 nm.

For more information about the 10GBASE-SR/SW SFP+ transceiver, including test and measurement information, see the IEEE 802.3ae standard.

### Caution:

#### Risk of equipment damage

To prevent damage to the optical receiver, ensure that at least 1 dB of attenuation exists between the transmit and receive ports.

The following table lists the specifications for the 10GBASE-SR/SW SFP+ transceivers. The part number of this SFP+ transceiver is AA1403015-E6.

**Table 25: IEEE 802.3ae 10GBASE-SR/SW SFP+ transceiver specifications**

Parameter	Specifications
Data rate	10 gigabits per second (Gbps)
Line rate (64B/66B code)	10.3125 Gbps $\pm$ 100 parts per million (ppm)
Center wavelength range	840 to 860 nanometers (nm), nominal 850 nm
Distance	Using 62.5 $\mu$ m MMF optic cable: <ul style="list-style-type: none"> <li>• 160 MHz-km fiber: 2 to 26 m</li> <li>• 200 MHz-km fiber: 2 to 33 m</li> </ul> Using 50 $\mu$ m MMF optic cable: <ul style="list-style-type: none"> <li>• 400 MHz-km fiber: 2 to 66 m</li> <li>• 500 MHz-km fiber: 2 to 82 m</li> <li>• 2000 MHz-km fiber: 2 to 300 m</li> <li>• 4700 MHz-km fiber (OM4): 2 to 400 m</li> </ul>
Link optical power budget	7.3 dB

*Table continues...*

Parameter	Specifications
Maximum transmitter and dispersion penalty	3.9 dB at 300 m
<b>Transmitter characteristics</b>	
Root-mean-square spectral width	0.05 to 0.40 nm
Launch power	-7.3 to -1.0 dBm
Minimum extinction ratio	3.0 dB
Maximum optical return loss tolerance	-12 dB
<b>Receiver characteristics</b>	
Average receive power for BER $10^{-12}$	-9.9 to -1.0 dBm
Receiver damage threshold	0 dBm
Maximum receiver sensitivity in OMA	-11.1 dBm
Maximum receiver reflectance	-12 dB
Stressed receiver sensitivity in OMA	-7.5 dBm

## 10GBASE-SR/SW SFP+ high temperature (0 °C to +85 °C) specifications

The 10GBASE-SR/SW SFP+ high temperature transceiver (0 °C to +85 °C) provides 10 GbE service at 850 nm.

The following table lists the specifications for the 10GBASE-SR/SW SFP+ transceiver (0 °C to +85 °C). The part number of this SFP+ transceiver is AA1403015-E6HT.

For more information about the 10GBASE-SR/SW SFP+ transceiver (0 °C to +85 °C), including test and measurement information, see the IEEE 802.3ae standard.

### Warning:

#### Risk of equipment damage

To prevent damage to the optical receiver, ensure that at least 1 dB of attenuation exists between the transmit and receive ports.

**Table 26: IEEE 802.3ae 10GBase-SR/SW SFP+ (0 °C to +85 °C) transceiver specifications**

Parameter	Specifications
Data rate	10 Gbps
Line rate (64B/66B code)	10.3125 gigabits per second (Gbps) ± 100 parts per million (ppm)
Center wavelength range	840 to 860 nanometers (nm), nominal 850 nm
Distance	Using 62.5 µm MMF optic cable: <ul style="list-style-type: none"> <li>• 160 MHz-km fiber: 2 to 26 m</li> <li>• 200 MHz-km fiber: 2 to 33 m</li> </ul> Using 50 µm MMF optic cable: <ul style="list-style-type: none"> <li>• 400 MHz-km fiber: 2 to 66 m</li> </ul>

*Table continues...*

Parameter	Specifications
	<ul style="list-style-type: none"> <li>• 500 MHz-km fiber: 2 to 82 m</li> <li>• 2000 MHz-km fiber (OM3): 2 to 300 m</li> <li>• 4700 MHz-km fiber (OM4): 2 to 400 m</li> </ul>
Link optical power budget	7.3 dB
Maximum transmitter and dispersion penalty	3.9 dB at 300 m
Operating case temperature range	0 °C to +85 °C
<b>Transmitter characteristics</b>	
Root-mean-square spectral width	0.05 to 0.40 nm
Launch power	-7.3 to -1.0 dBm
Minimum extinction ratio	3.0 dB
Maximum optical return loss tolerance	-12 dB
<b>Receiver characteristics</b>	
Average receive power for BER 10 <sup>-12</sup>	-9.9 to -1.0 dBm
Receiver damage threshold	0dBm
Maximum receiver sensitivity in OMA	-11.1 dBm
Maximum receiver reflectance	-12 dB
Stressed receiver sensitivity in OMA	-7.5 dBm

## 10GBASE-ZR/ZW SFP+ specifications

The following table lists the transmit and receive specifications for the 10GBASE-ZR/ZW SFP+ transceiver. The part number of this SFP+ transceiver is AA1403016-E6.

### \* Note:

VSP 7254XSQ has a PHYless design which is typical for Data Center Top of Rack switches. The benefits of a PHYless design are lower power consumption and lower latency. However, due to the PHYless design, this transceiver is not supported. For the VSP 7200 Series, use the 10GBASE-ZR CWDM DDI SFP+ transceiver with part number AA1403165-E6.

### ⚠ Warning:

Risk of BER increase

For proper SFP+ transceiver operation, ensure that at least 11 dB of attenuation is present between the transmit and receive ports.

The reach for this SFP+ transceiver is up to 70 km\* at a wavelength of 1550 nm.

**Table 27: 10GBASE-ZR/ZW SFP+ specifications**

Parameter	Specifications
Line rate (nominal)	10GBASE-ZR 10.3125 Gbps ±100 ppm (10 GbE)

*Table continues...*

Parameter	Specifications
Distance	Up to 70 km *
Link optical power budget	24 dB
Dispersion power penalty	3.0 dB at 70 km (G.652 fiber)
Minimum attenuation between transmit and receive ports	11 dB
<b>Transmitter characteristics</b>	
Center wavelength range	1530 to 1565 nm, nominal 1550 nm
Average launch power	0 to 4.0 dBm
Optical modulation amplitude (minimum)	-1.7 dBm
Extinction ratio (ER) (minimum)	8.2 dB
Maximum transmitter reflectance	-12 dB
<b>Receiver characteristics</b>	
Wavelength range	1280 to 1575 nm. Sensitivity specified for 1530 to 1565 nm.
Maximum receiver sensitivity (average power)	-24 dBm
Maximum receiver (average) power, BER 10 <sup>-12</sup>	-7.0 dBm
Receiver damage threshold (average power)	+5.0 dBm
Receiver reflectance (maximum)	-27 dB

\* Achievable link distance is primarily dependent on cable plant insertion loss. 70 km is not possible in some situations.

## 10GBASE-ER CWDM SFP+ specifications

The following table lists the part numbers for the 10GBASE-ER CWDM SFP+ transceivers with corresponding wavelengths.

**Table 28: Part number and center wavelength assignment**

Part number	Center wavelength assignment	Reach	Minimum insertion loss
AA1403153-E6	1471 nm	Up to 40 km	5 dB between Tx and Rx
AA1403154-E6	1491 nm	Up to 40 km	5 dB between Tx and Rx
AA1403155-E6	1511 nm	Up to 40 km	5 dB between Tx and Rx
AA1403156-E6	1531 nm	Up to 40 km	5 dB between Tx and Rx
AA1403157-E6	1551 nm	Up to 40 km	5 dB between Tx and Rx
AA1403158-E6	1571 nm	Up to 40 km	5 dB between Tx and Rx
AA1403159-E6	1591 nm	Up to 40 km	5 dB between Tx and Rx
AA1403160-E6	1611 nm	Up to 40 km	5 dB between Tx and Rx

*Table continues...*

Part number	Center wavelength assignment	Reach	Minimum insertion loss
AA1403161-E6	1471 nm	Up to 70 km.	5 dB between Tx and Rx
AA1403162-E6	1491 nm	Up to 70 km	5 dB between Tx and Rx
AA1403163-E6	1511 nm	Up to 70 km	5 dB between Tx and Rx
AA1403164-E6	1531 nm	Up to 70 km	5 dB between Tx and Rx
AA1403165-E6	1551 nm	Up to 70 km	5 dB between Tx and Rx
AA1403166-E6	1571 nm	Up to 70 km	5 dB between Tx and Rx
AA1403167-E6	1591 nm	Up to 70 km	5 dB between Tx and Rx
AA1403168-E6	1611 nm	Up to 70 km	5 dB between Tx and Rx

The following table lists the transmitter and receiver specifications for the 10GBASE-ER CWDM SFP+ transceivers.

**Table 29: 10GBASE-ER CWDM SFP+ specifications**

Parameter	Specifications
<b>Transmitter characteristics</b>	
Optical Data Rate (nominal)	9.95 Gbps to 10.313 Gbps
Center wavelength	Nominal –6.5 nm to nominal +6.5 nm
Spectral width (rms at -20 dB)	1 nm
Side Mode Suppression ratio	30 dB
RIN	–128 dB/Hz
Average launched power	–0.2 dBm to 4 dBm
Average launched power, Tx OFF	–30 dBm
Extinction ratio (minimum)	8.2 dB
Tx power, OMA (minimum)	+1.5 dBm
Tx power, OMA-TDP (minimum)	–0.2 dBm
TDP at 800 ps dispersion (maximum)	2.8 dB
IEEE 10GBASE-ER eye mask margin	10%
<b>Receiver characteristics</b>	
Wavelength (requirement)	1450 nm to 1620 nm
Receiver sensitivity (unstressed), OMA	–14.1 dBm, P_OMA
IEEE 10GBASE-ER Stressed Rx Sensitivity	–11.3 dBm, P_OMA
Receiver overload	–1 dBm, P_avg
Receiver reflectance	–26 dB
Receiver damage threshold	+4 dBm

## 10GBASE-LRM SFP+ specifications

The 10GBASE-LRM SFP+ transceiver provides 10 GbE service at a wavelength of 1310 nm. This SFP+ transceiver can attain a reach of up to 220 m on 62.5  $\mu$ m multimode fiber.

The following table lists the transmitter and receiver specifications for the 10GBASE-LRM SFP+ transceiver. These parameters meet the IEEE 802.3aq-2006 standard. The part number of this SFP+ transceiver is AA1403017-E6.

**\* Note:**

VSP 7254XSQ has a PHYless design, which is typical for Data Center Top of Rack switches. The benefits of a PHYless design are lower power consumption and lower latency. However, due to the PHYless design, this transceiver is not supported.

In this table, the OMA, average launch power, and peak power specifications apply at TP2, after accounting for patch cord loss.

**Table 30: IEEE 802.3aq 10GBASE-LRM SFP+ transceiver specifications**

Parameter	Specifications
Data rate	10 Gbps
Line rate (64B/66B code)	10.3125 Gbps $\pm$ 100 ppm
Center wavelength range	1260 to 1355 nm; 1310 nm nominal
Distance	Up to 220 m
Link optical power budget	1.7 to 1.9 dB
Maximum transmitter waveform and dispersion penalty (TWDP)	4.7 dB
<b>Transmitter characteristics</b>	
Average launch power	−6.5 to 0.5 dBm
Peak launch power	3 dBm
Root-mean-square spectral width	2.4 to 4 nm
Launch power in OMA	−4.5 to 1.5 dBm
Minimum extinction ratio	3.5 dB
Optical return loss tolerance (minimum)	−20 dB
<b>Receiver characteristics</b>	
Receiver damage threshold	1.5 dBm
Receiver reflectance (maximum)	−12 dB

For more information about the conditions used for the stressed receiver tests, and other information, see the IEEE 802.3–2012 standard.

The following table (from IEEE 802.3–2012) describes the maximum channel insertion loss. The channel insertion loss includes both attenuation and connector loss (1.5 dB); therefore the maximum fiber attenuation is 0.2 to 0.4 dB.

**Table 31: 10GBASE-LRM channel insertion loss and range**

Fiber type (core diameter and OFL bandwidth)	Range	Maximum channel insertion loss
62.5 µm (FDDI grade) • 160 MHz-km at 850 nm • 500 MHz-km at 1300 nm	Up to 220 m	1.9 dB
62.5 µm (ISO/IEC OM1) • 200 MHz-km at 850 nm • 500 MHz-km at 1300 nm	Up to 220 m	1.9 dB
50 µm (ISO/IEC OM2) • 500 MHz-km at 850 nm • 500 MHz-km at 1300 nm	Up to 220 m	1.9 dB
50 µm • 400 MHz-km at 850 nm • 400 MHz-km at 1300 nm	Up to 100 m	1.7 dB
50 µm (ISO/IEC OM3) • 1500 MHz-km at 850 nm (includes laser launch bandwidth) • 500 MHz-km at 1300 nm (includes laser launch bandwidth)	Up to 220 m	1.9 dB

The following abbreviations are used in the preceding tables:

- FDDI – Fiber Distributed Data Interface
- ISO – International Standards Organization
- IEC – International Electrotechnical Commission
- OFL – Over Filled Launch

## 10GBASE-CX specifications

The 10GBASE-CX is a 2-pair twinaxial copper cable that plugs into the SFP+ socket and connects two 10-gigabit ports. The reach for this cable is up to 15 m with a bit error rate (BER) better than  $10^{-12}$ .

The 10GBASE-CX is a lower cost alternative to the optical SFP+ devices.

For more information about the 10GBASE-CX, including test and measurement information and more specifications, see the IEEE 802.3–2012 standard. The following table identifies the part numbers for specific cable lengths.

**Table 32: 10GBASE-CX cables**

Cable length	Part number
3 meter	AA1403019-E6
5 meter	AA1403020-E6
10 meter	AA1403018-E6

## 10GBASE-ZR CWDM DDI SFP+ specifications

The following table lists the part numbers for the 10GBASE-ZR CWDM DDI SFP+ transceivers with corresponding wavelengths.

The reach for this SFP+ transceiver is up to 70 km\* at a wavelength of 1551 nm.

**Table 33: Part number and center wavelength assignment**

Part number	Center wavelength assignment	Reach	Minimum insertion loss
AA1403161-E6	1471 nm	70 km	10 dB between Tx and Rx
AA1403162-E6	1491 nm	70 km	10 dB between Tx and Rx
AA1403163-E6	1511 nm	70 km	10 dB between Tx and Rx
AA1403164-E6	1531 nm	70 km	10 dB between Tx and Rx
AA1403165-E6	1551 nm	70 km	10 dB between Tx and Rx
AA1403166-E6	1571 nm	70 km	10 dB between Tx and Rx
AA1403167-E6	1591 nm	70 km	10 dB between Tx and Rx
AA1403168-E6	1611 nm	70 km	10 dB between Tx and Rx

The following table lists the transmitter and receiver specifications for the 10GBASE-ZR CWDM DDI SFP+ transceiver.

**Table 34: 10GBASE-ZR CWDM DDI SFP+ specifications**

Parameter			Specifications
<b>Transmitter characteristics</b>			
Optical Data Rate (nominal)			9.95 Gbps to 10.313 Gbps
Center wavelength			Nominal -6.5 nm to nominal +6.5 nm
Spectral width (RMS at -20 dB)			1 nm
RIN OMA			-128 dB/Hz
Extinction ratio (minimum)			8.2 dB
Tx output:	Min	Max	Units
P_avg	-1	4	dBm
OMA	+0.7	—	dBm

*Table continues...*



Parameter			Specifications
OMA-TDP	-2.3	—	dBm
TDP at 1400 ps dispersion			3 dB
Optical return loss tolerance			21 dB
<b>Receiver characteristics</b>			
Wavelength range			1460 nm to 1620 nm
Rx sensitivity:	Min	Max	Units
back-to-back	—	-23	dBm
with 70 km fiber	—	-21	dBm
with 70 km fiber, OMA	—	-19.3	dBm
Receiver overload			-7 dBm, P_avg
Receiver reflectance			-27 dB
Receiver damage threshold			+5 dBm, P_avg

\* Achievable link distance is primarily dependent on cable plant insertion loss. 70 km is not possible in some situations.

## 10GBASE-BX SFP+ specifications

The 10GBASE-BX SFP+ provides 10 Gigabit Ethernet (GbE) service with single mode bidirectional transceivers. One transceiver transmits at 1270 nm and receives at 1330 nm and the mating transceiver transmits at 1330 nm and receives at 1270 nm.

### \* Note:

Transceivers AA1403169-E6 and AA1403170-E6 must be used only as a pair.

The following table provides the wavelength and distance details for the transceiver pair:

AA1403169-E6	1270 nm Tx	1330 nm Rx	up to 10 km	Paired with AA1403170-E6
AA1403170-E6	1330 nm Tx	1270 nm Rx	up to 10 km	Paired with AA1403169-E6

The following table lists the specifications for the 10GBASE-BX SFP+ transceivers.

Parameter	Specifications
Connector	Single-fiber LC
Data rate	10 Gbps
Line rate	10.3125 Gbps
Distance	Up to 10 km
Single power supply	3.3 V
Maximum transmitter and dispersion penalty	3.2 dBm
Operating case temperature range	-40 to +85 °C
<b>Transmitter characteristics</b>	

*Table continues...*

Parameter	Specifications
Wavelength	1270 +/- 10 nm or 1330 +/- 10 nm
Launch power	-8.2 to +0.5 dBm
Average launch power of OFF transmitter $p_{OFF}$	-30 dBm
Minimum extinction ratio	3.5 dB
Optical Modulation Amplitude $p_{OMA}$	-5.2 dBm
OMA-TDP, min	-6.2 dBm
<b>Receiver characteristics</b>	
Wavelength	1330 +/- 10 nm or 1270 +/- 10 nm
Average receive power	-14.4 to +0.5 dBm
Maximum receiver sensitivity in OMA	-12.6 dBm
Maximum receiver reflectance	-12 dB
Stressed receiver sensitivity in OMA	-10.3 dBm

## SFP+ cable assembly specifications

This section provides cable assembly specifications for Small Form Factor Pluggable plus (SFP+) transceivers.

## SFP+ direct attach cable specifications

This section provides technical specification for the supported direct attach cable (DAC).

Cable type	Cable length	Minimum software version			Part number
		VSP 7200	VSP 8200	VSP 8400	
10GBASE-CX SFP+ 2-pair twinaxial copper cable that plugs into the SFP+ socket and connects two 10-gigabit ports	10 meter	4.2.1	4.0.0	4.2.0	AA1403018-E6
10GBASE-CX SFP+ 2-pair twinaxial copper cable that plugs into the SFP+ socket and connects two 10-gigabit ports	3 meter	4.2.1	4.0.0	4.2.0	AA1403019-E6
10GBASE-CX SFP+ 2-pair twinaxial copper cable that plugs into the SFP+ socket and connects two 10-gigabit ports	5 meter	4.2.1	4.0.0	4.2.0	AA1403020-E6

# Chapter 6: QSFP+

This chapter provides installation procedures and specifications for 40-gigabit Ethernet Quad Small Form Factor Pluggable plus (QSFP+) transceiver modules.

---

## QSFP+ transceivers

This section describes how to select, install, and remove Quad (4-channel) Small Form Factor Pluggable plus (QSFP+) transceiver modules.

Use a QSFP+ transceiver to connect a device motherboard to fiber optic or direct attach cables. QSFP+ transceivers support 40 gigabit per second (Gbps) connections.

The Avaya Virtual Services Platform 8000 Series supports QSFP+ transceivers on the following ESMs

- The Avaya 8200 supports only four 40Gbps ports on 1/41, 1/42, 2/41 and 2/42.
- The Avaya VSP 8400 ports can be used with QSFP+ transceivers depending on the type of Ethernet Switch Modules (ESM) installed. For information on ESM types, see *Installing the Avaya Virtual Services Platform 8000 Series*, NN47227-300.
- The Avaya VSP 7200 Series supports 40Gbps QSFP+ transceivers on ports 2/1–2/6.

### ! Important:

- The VSP 8000 and VSP 7200 Series operate in strict mode for QSFP+ transceivers, which means that the switch will not bring the port up operationally when using non-Avaya QSFP+ transceivers.
- The VSP 8000 and VSP 7200 Series operate in forgiving mode for QSFP+ direct attach cables (DACs), which means that the switch will bring up the port operationally when using non-Avaya direct attach cables. Avaya does not provide support for operational issues related to these DACs, but they will operate and the port link will come up.

### \* Note:

Although VSP 8000 and VSP 7200 Series support 10G and 40G DAC cables in forgiving mode, the output to the command `show pluggable-optical-modules basic` displays the corresponding vendor names instead of leaving the vendor name blank as in the releases prior to VOSS 4.2.1.

## Selecting a QSFP+

Use a QSFP+ transceiver to interface a port to a fiber optic cable. Depending on the product, you can obtain QSFP+ transceivers for cable distances of up to 40 km. Alternatively, you can use a direct attach cable (QSFP+ to QSFP+ DAC) to connect ports for cable distances of up to 5 meters.

### About this task

Select the appropriate transceiver to provide the required reach.

### Procedure

1. Determine the required reach.
2. Determine wavelength restrictions or requirements.
3. Use the following job aid to determine the appropriate QSFP+ transceiver or cable for your application.

### Job aid

QSFP+ transceivers are hot-swappable data input and output components that allow 40-gigabit Ethernet ports to link with other 40-gigabit Ethernet ports.

All Avaya QSFP+ transceivers use LC connectors and MPO/MTP connectors to provide precision keying and low interface losses.

The following table lists and describes the Avaya QSFP+ transceiver models.

**Table 35: Compatible 40-gigabit QSFP+ transceiver models**

Cable type	Cable length	Minimum software version			Part number
		VSP 7200	VSP 8200	VSP 8400	
Passive copper DAC	0.5 meter	4.2.1	4.0.0	4.2.0	AA1404037-E6
Passive copper DAC	1 meter	4.2.1	4.0.0	4.2.0	AA1404029-E6
Passive copper DAC	3 meter	4.2.1	4.0.0	4.2.0	AA1404031-E6
Passive copper DAC	5 meter	4.2.1	4.0.0	4.2.0	AA1404032-E6
40GBASE-LR4 QSFP+	10 km	4.2.1	4.0.0	4.2.0	AA1404001-E6
40GBASE-SR4 4x10GBASE-SR QSFP+	100 meters with OM3 fiber cable	4.2.1	4.0.0	4.2.0	AA1404005-E6

*Table continues...*

Cable type	Cable length	Minimum software version			Part number
		VSP 7200	VSP 8200	VSP 8400	
	150 meters with OM4 fiber cable				
Passive copper breakout cable	1 meter	4.2.1	4.2.0	4.2.0	AA1404033-E6
Passive copper breakout cable	3 meter	4.2.1	4.2.0	4.2.0	AA1404035-E6
Passive copper breakout cable	5 meter	4.2.1	4.2.0	4.2.0	AA1404036-E6
Active optical DAC	10 meter	4.2.1	4.2.1	4.2.1	AA1404028-E6
Active optical breakout cable	10 meter	4.2.1	4.2.1	4.2.1	AA1404041-E6
40GBASE-LM4 QSFP+	80 meters on 50 $\mu$ m multimode fiber	4.2.1	4.2.1	4.2.1	AA1404002-E6
40GBASE-ER4 QSFP+	40 km	4.2.1	4.2.1	4.2.1	AA1404003-E6
<p> <b>Warning:</b> Do not use a short jumper or loopback cable. Ensure at least 1.8 dB insertion loss exists between the transmitter and receiver to avoid permanent receiver damage.</p>					

## Installing a QSFP+ transceiver

Install a QSFP+ transceiver to provide a 40-gigabit Ethernet interface between the device and other network devices.

## Before you begin

- Verify that the QSFP+ is the correct model for your network configuration.
- Before you install the optical connector, ensure it is clean.

### **Danger:**

#### **Risk of eye injury by laser**

Fiber optic equipment can emit laser or infrared light that can injure your eyes. Never look into an optical fiber or connector port. Always assume that fiber optic cables connect to a light source.

### **Electrostatic alert:**

#### **Risk of equipment damage**

ESD can damage electronic circuits. Do not touch electronic hardware unless you wear a grounding wrist strap or other static-dissipating device.

### **Warning:**

#### **Risk of equipment damage**

Only trained personnel can install this product.

### **Warning:**

#### **Risk of equipment damage**

QSFP+ transceivers are keyed to prevent incorrect insertion. If the QSFP+ resists pressure, do not force it; turn it over, and reinsert it.

## About this task

Installing a QSFP+ takes approximately 3 minutes.

## Procedure

1. Remove the QSFP+ from its protective packaging.
2. Remove the dust cover from the QSFP+ optical bores and insert the fiber optic cable.
3. Grasp the QSFP+ between your thumb and forefinger.
4. Insert the device into a QSFP+ port.

Apply a light pressure to the QSFP+ until the device clicks and locks into position in the port.

## Job aid

Avaya uses the QSFP+ transceiver with the pull-tab type of locking and extractor mechanism.

The following figure shows the QSFP+ transceiver with a bore plug installed. Pull the tab to release the device.

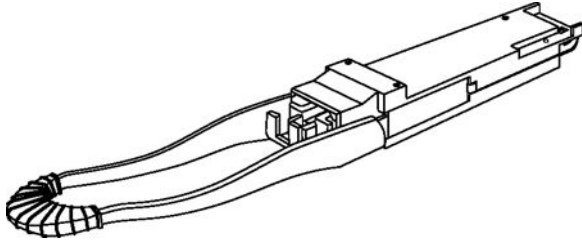

## Removing a QSFP+ transceiver

Remove a QSFP+ transceiver to replace it or to commission it elsewhere.

### Before you begin

#### **Danger:**

##### **Risk of eye injury by laser**

Fiber optic equipment can emit laser or infrared light that can injure your eyes. Never look into an optical fiber or connector port. Always assume that fiber optic cables connect to a light source.

#### **Electrostatic alert:**

##### **Risk of equipment damage**

To prevent damage from electrostatic discharge, always wear an antistatic wrist strap connected to an electrostatic discharge (ESD) jack.

### Procedure

1. Disconnect the network fiber optic cable from the QSFP+ connector.
2. Grasp the pull-tab and slide the QSFP+ transceiver out of the module QSFP+ slot.

If the QSFP+ transceiver does not slide easily from the module slot, use a gentle side-to-side rocking motion while firmly pulling the QSFP+ transceiver from the slot.

3. Remove connector from transceiver and affix dust covers over the fiber optic bore and connector.
4. Store the QSFP+ transceiver in a safe place until needed.

#### **Important:**

If you discard the QSFP+ transceiver, dispose of it according to all national laws and regulations.

## QSFP+ transceiver specifications

This section provides technical specifications for the supported 40 gigabit QSFP+ transceiver models. Use these specifications to aid in network design.

**! Important:**

The VSP 8000 and VSP 7200 Series operate in strict mode for QSFP+ transceivers, which means that the switch will not bring the port up operationally when using non-Avaya QSFP+ transceivers.

## QSFP+ transceiver labels

A label can be located on either the top or bottom of the typical Avaya QSFP+ transceiver. The following figure shows an example label.

Avaya uses alternate labels, depending on the size of the device and space available for label information.

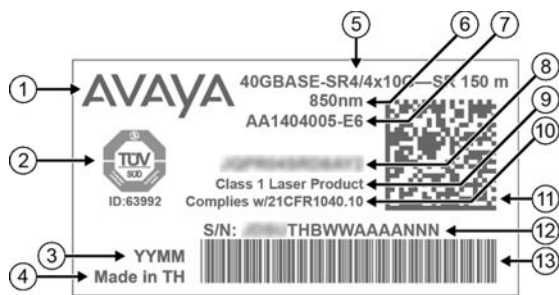

**Figure 4: 40GBASE-SR4 QSFP+ transceiver label example**

The following table identifies the numbered items in the preceding figure.

**Table 36: Figure notes for a 40GBASE-SR4 QSFP+ transceiver label**

1. Avaya logo
2. Optical safety certification logos
3. Year and month of manufacture
4. Country of origin
5. Name
6. Operating wavelength
7. Avaya PEC
8. Vendor part number
9. U.S. FDA CDRH laser classification
10. U.S. FDA CDRH laser classification compliance number

*Table continues...*



11. 2D serial number barcode
12. Serial number
13. 1D serial number barcode

## General QSFP+ transceiver specifications

The following table describes general QSFP+ transceiver specifications.

**Table 37: General QSFP+ specifications**

Parameter		Specification
Dimensions (H x W x D)		8.5 x 18.35 x 72.4 mm (0.33 x 0.72 x 2.85 in.), unless otherwise stated.   <b>Note:</b> The length of the pull tab latch varies depending on the vendor and the body, with a length of 125 to 132 mm (4.92 to 5.20 in.).
Connectors	40GBASE-SR4 QSFP+	MPO or MTP
	40GBASE-LR4 QSFP+	LC Duplex
Storage temperature		-40 °F (-4 °C) to 185 °F (85 °C)
Operating temperature		23 °F (-5 °C) to 158 °F (70 °C)

## Supported QSFP+ transceivers

The following section provides specifications for supported QSFP+ transceivers.

### 40GBASE-SR4 QSFP+ specifications

The 40GBASE-SR4 4x10GBASE-SR transceiver provides a high-speed link at an aggregate signaling rate.

#### Important:

Not all Avaya networking products support the 4x10GBASE-SR mode of operation.

The 40GBASE-SR4 transceiver supports the MPO connector and the duplex LC connector. Typically, the MPO connector has two alignment pins, which keeps the connector and the fibers aligned to the mating cable.

For more information about the 40GBASE-SR4 4x10GBASE-SR QSFP+ transceiver, including test and measurement information, see the IEEE 802.3-2012 standard.

The following table lists the specifications for the 40GBASE-SR4 4x10GBASE-SR QSFP+ transceiver. The part number of this QSFP+ transceiver is AA1404005-E6.

**Table 38: 40GBASE-SR4 4x10GBASE-SR QSFP+ transceiver specifications**

Parameter		Specification	
Line rate		10.3125 Gbps	
Center wavelength range		840 to 860 nanometers	
Distance		Up to: <ul style="list-style-type: none"> <li>• 328 feet (100 meters) – with OM3 fiber cable.</li> <li>• 492 feet (150 meters) – with OM4 fiber cable.</li> </ul>	
<b>Transmitter characteristics</b>			
Signaling rate, each lane		10.3125 Gbps	
RMS spectral width		0.65 nanometers maximum	
Average launch power, each lane	<b>Min</b>	<b>Max</b>	<b>Units</b>
	-8.0	-1.0	dBm
Optical modulation amplitude (OMA), each lane	<b>Min</b>	<b>Max</b>	<b>Units</b>
	-5.6	3	dBm
Maximum transmitter and dispersion penalty (TDP), each lane		3.9 dB	
Minimum launch power in OMA minus TDP, each lane		-7.8 dBm	
Minimum extinction ratio		3 dB	
Maximum optical return loss tolerance		12 dB	
<b>Receiver characteristics</b>			
Signaling rate, each lane		10.3125 Gbps	
Average receive power, each lane	<b>Min</b>	<b>Max</b>	<b>Units</b>
	-9.5	2.4	dBm
Receive power in OMA, each lane	<b>Min</b>	<b>Max</b>	<b>Units</b>
	-7.5	3	dBm
Receive input optical power (damage threshold)		3.4 dBm	

## 40GBASE-LR4 QSFP+ transceiver specifications

The 40GBASE-LR4 QSFP+ transceiver can attain link lengths of up to 10 kilometers on International Telecommunication Union (ITU) recommendation G.652 single-mode fiber (SMF) cable.

The following table lists the transmitter and receiver specifications for the 40GBASE-LR4 transceiver. The part number of this QSFP+ transceiver is AA1404001-E6.

For more information about the 40GBASE-LR4 transceiver, including test and measurement information, see the IEEE 802.3–2012 standard.

**Table 39: IEEE 802.3–2012 40GBASE-LR4 transceiver specifications**

Parameter	Specification
Distance	Up to 10 kilometers
<b>Transmitter characteristics</b>	
Line rate	10 Gbps
Signaling rate, each lane 10GBase	10.3125 Gbps
Data rate, total 40GBase	41.25 Gbps
Lane wavelength ranges	1264.5 nanometers to 1277.5 nanometers 1284.5 nanometers to 1297.5 nanometers 1304.5 nanometers to 1317.5 nanometers 1324.5 nanometers to 1337.5 nanometers
Total average optical power	8.3 dBm
Minimum average optical power, each lane at 10.3125 Gbps.	-7 dBm
Maximum average optical power, each lane at 10.3125 Gbps.	2.3 dBm
Difference in optical power between any two lanes	6.5 dB
Minimum side mode suppression ratio	30 dB
Minimum optical modulation amplitude	-4 dBm
Maximum optical modulation amplitude	3.5 dBm
Maximum average optical power of OFF transmitter, each lane	-30 dBm
Minimum extinction ratio at 10.3125 Gbps	3.5 dB
RIN <sub>20</sub> OMA (maximum)	-128 dB/Hz
Maximum optical return loss tolerance	20 dB
<b>Receiver characteristics</b>	
Line rate	10 Gbps
Signaling rate, each lane 10GBase	10.3125 Gbps
Data rate, total 40GBase	41.25 Gbps
Lane wavelength ranges	1264.5 nanometers to 1277.5 nanometers 1284.5 nanometers to 1297.5 nanometers 1304.5 nanometers to 1317.5 nanometers 1324.5 nanometers to 1337.5 nanometers
Average receive power, each lane at 10.3125 Gbps.	-13.7 to 2.3 dBm
Maximum receiver power, each lane in OMA.	3.5 dBm

*Table continues...*

Parameter	Specification
Maximum receiver sensitivity in OMA, each lane at 10.3125 Gbps.	-11.5 dBm
Maximum receiver reflectance	-26 dBm
Stressed receiver sensitivity, each lane at 10.3125 Gbps.	-9.6 dBm
Receive input optical power (damage threshold per lane)	3.3 dBm

## 40GBASE-LM4 QSFP+ specifications

This transceiver operates up to 80 meters on 50  $\mu$ m MMF cable plant and is compliant with channel insertion loss specified in IEEE standard 802.3-2012, Table 52-10, for 2000 (OM3) or 4700 MHz\*km (OM4) 50  $\mu$ m multimode fiber.

### \* Note:

Channel insertion loss includes connectors.

The 40GBASE-LM4 QSFP+ transceiver supports a link configuration of a backbone cable between patch panels with one jumper from the transceiver to the patch panel at each end. All ends support duplex LC connectors. Connector return loss requirement is 20 dB or greater (reflectance -20 dB or less).

Other 10GBASE-S transceivers and link parameters do not apply, as the LM4 operates in the 1310 nm region. The 40GBASE-LM4 QSFP+ transceiver contains four transmitters where the signal is internally multiplexed to the Tx port and contains four receivers where the signal is internally demultiplexed at the Rx port.

The 40GBASE-LM4 QSFP+ transceiver replaces a 40GBASE-SR4 QSFP+ transceiver for applications up to 80 meters. The transceiver uses one pair of MMF fibers and a duplex LC connector versus the eight fibers with MPO/MTP connectors that are used with the 40GBASE-SR4 QSFP+ transceiver. The transceiver is not interoperable with 40GBASE-SR4 or 10GBASE-SR transceivers.

The following table lists the transmitter, cable plant, and receiver specifications for the 40GBASE-LM4 QSFP+ transceiver. The part number is AA1404002-E6.

Parameter	Specification
Data rate (nominal)	4 X 10 Gbps
Nominal transmitter center wavelengths	1271, 1291, 1311, 1331
Link distance (OM3 and OM4)	Up to 80 m maximum
Operating temperature range	0 °C to +70 °C
<b>Transmitter characteristics</b>	
Maximum total average launch power	10.3 dBm
Maximum average launch power, each lane	4.3 dBm
Maximum average launch power of OFF transmitter	-30 dBm

*Table continues...*

Parameter	Specification
Maximum optical return loss tolerance	20 dB
<b>Applicable cable plant</b>	
Maximum insertion loss, including connectors	2.6 dB (OM3) or 2.9 dB (OM4)
Minimum optical return loss	20 dB
Maximum link distance	80 m
<b>Receiver characteristics</b>	
Maximum average receive power, each lane	4.3 dBm
Maximum input optical power	Tolerates direct Tx to Rx connection
Stressed receiver sensitivity	-5.0 dBm

### 40GBASE-ER4 QSFP+ specifications

The following table lists the transmitter and receiver specifications for the 40GBASE-ER4 QSFP+ transceiver with corresponding wavelengths. The reach for this QSFP+ transceiver is up to 40 kilometers. The part number is AA1404003-E6.

 **Warning:**

Do not use a short jumper or loopback cable. Ensure at least 1.8 dB insertion loss exists between the transmitter and receiver to avoid permanent receiver damage.

A minimum of 9 dB insertion loss must exist between the transmitter and receiver for correct operation. If the fiber cable does not have this much loss, use an attenuator to meet the 9 dB requirement. No attenuator is needed if insertion loss is at least 9 dB.

**Table 40: IEEE 802.3ae 40GBASE-ER4 QSFP+ specifications**

Parameter	Specification
Distance	Up to 40 kilometers
Loss budget	18.5 dB
<b>Transmitter characteristics</b>	
Line rate	10 Gbps
Signaling rate, each lane 10GBASE	10.3125 Gbps
Lane wavelength ranges	1264.5 nanometers to 1277.5 nanometers 1284.5 nanometers to 1297.5 nanometers 1304.5 nanometers to 1317.5 nanometers 1324.5 nanometers to 1337.5 nanometers
Total average optical power	10.5 dBm
Average optical power, each lane at 10.3125 Gbps	Min. -2.7 Max. 4.5 Units dBm

*Table continues...*

Difference in optical power between any two lanes			4.7 dB OMA
Minimum side mode suppression ratio			30 dBm
Optical modulation amplitude	Min. 0.3	Max. 5	Units dBm
Maximum average optical power of OFF transmitter, each lane			-30 dBm
Launch power in OMA minus TDP, each lane, (min.)			-0.5 dBm
Minimum extinction ratio at 10.3125 Gbps			5.5 dB
RIN <sub>20</sub> OMA (maximum)			-128 dB/Hz
Maximum optical return loss tolerance			20 dB
<b>Receiver characteristics</b>			
Line rate			10 Gbps
Signaling rate, each lane 10GBASE			10.3125 Gbps
Damage threshold per lane (min.)			3.8 dBm
Lane wavelength ranges			1264.5 nanometers to 1277.5 nanometers 1284.5 nanometers to 1297.5 nanometers 1304.5 nanometers to 1317.5 nanometers 1324.5 nanometers to 1337.5 nanometers
Average receive power, each lane at 10.3125 Gbps			-21.2 to -4.5 dBm
Maximum receiver power, each lane in OMA			-4 dBm
Receiver sensitivity (OMA), each lane			-19 dBm
Stressed receiver sensitivity (OMA), each lane (max.)			-16.8 dBm
Maximum receiver reflectance			-26 dBm

## Link Engineering for greater than 30 km operation

### Caution:

Operating ranges that are greater than 30 km for the same link power budget are considered engineered links. If your operating range is greater than 30 km, you require engineering skills to determine correct device and cable plant specifications, and installation practices. Avaya recommends that you consider the potential impact of operating with near zero assured margin.

The following list provides the requirements for achieving operation to 40 km:

- Ensure fiber insertion loss, in dB/km, is less than (18.5 – connector loss, dB)/length.
- Observe strict limits on number and insertion loss of connectors.
- Note that operation to 40 km can possibly eliminate power margin allocated to aging, additional connectors, or cable repairs. This increases risk of additional remediation effort in the event of cable or configuration changes. Cable cuts are the dominant cause of link failure and have been observed to occur on average 4.39 times per thousand sheath miles per year.

**Table 41: 40GBASE-ER4 operating ranges**

Required operating range
2 m to 30 km
2 m to 40 km

### Interoperation

40GBASE-ER4 and 40GBASE-LR4 QSFP+ transceivers can interoperate with a properly-engineered link. It requires the cabling (channel) characteristics for 40GBASE-LR4 to be met, with the exception of the maximum and minimum channel insertion loss values, as shown in the following table, for the two link directions separately.

Direction	Min. loss	Max. loss	Unit
40GBASE-LR4 transmitter to 40GBASE-ER4 receiver	7.5	14.2	dB
40GBASE-ER4 transmitter to 40GBASE-LR4 receiver	2.2	11	dB

## QSFP+ cable assembly specifications

This section provides cable assembly specifications for the supported 40-gigabit QSFP+ transceiver module.

### Important:

The VSP 8000 and VSP 7200 Series operate in forgiving mode for QSFP+ direct attach cables, which means that the switch will bring up the port operationally when using non-Avaya direct attach cables. Avaya does not provide support for operational issues related to these DACs, but they will operate and the port link will come up.

## QSFP+ breakout cable specifications

This section provides technical specifications for the supported breakout cables (BOC).

### QSFP+ to four SFP+ 10-gigabit BOC

The QSFP+ to four SFP+ 10-gigabit direct attach breakout cable assembly directly connects one QSFP+ port to four SFP+ ports.

The following table identifies the part numbers for specific cable assembly lengths.

Cable type	Cable length	Minimum software version			Part number
		VSP 7200	VSP 8200	VSP 8400	
Passive copper breakout cable	1 meter	4.2.1	4.2.0	4.2.0	AA1404033-E6
Passive copper breakout cable	3 meter	4.2.1	4.2.0	4.2.0	AA1404035-E6
Passive copper breakout cable	5 meter	4.2.1	4.2.0	4.2.0	AA1404036-E6
Active optical breakout cable	10 meter	4.2.1	4.2.1	4.2.1	AA1404041-E6

## QSFP+ to QSFP+ 40-gigabit direct attach cable specifications

The QSFP+ to QSFP+ 40-gigabit Direct Attach Cable (DAC) assembly directly connects two QSFP+ ports. For more information, see the IEEE 802.3ba 40GBASE-CR4 cable assembly specification standard.

The following table identifies the part numbers for specific cable assembly lengths.

Cable type	Cable length	Minimum software version			Part number
		7200	8200	8400	
Passive flexi-DAC (TAA)	0.5 meter	4.2.1	4.0.0	4.2.0	AA1404037-E6
Passive copper DAC	1 meter	4.2.1	4.0.0	4.2.0	AA1404029-E6
Passive copper DAC	3 meter	4.2.1	4.0.0	4.2.0	AA1404031-E6
Passive copper DAC	5 meter	4.2.1	4.0.0	4.2.0	AA1404032-E6
Active optical DAC	10 meter	4.2.1	4.2.1	4.2.1	AA1404028-E6

### Important:

Not all Avaya products support all cable lengths.



# Chapter 7: Translations of safety messages

---

## Class A electromagnetic interference warning statement

 **Warning:**

**Risk of electromagnetic interference**

This device is a Class A product. Operation of this equipment in a residential area is likely to cause harmful interference, in which case users are required to take appropriate measures necessary to correct the interference at their own expense.

 **Warning:**

**AVERTISSEMENT**

Le périphérique est un produit de Classe A. Le fonctionnement de cet équipement dans une zone résidentielle risque de causer des interférences nuisibles, auquel cas l'utilisateur devra y remédier à ses propres frais.

 **Warning:**

**WARNUNG**

Dies ist ein Gerät der Klasse A. Bei Einsatz des Geräts in Wohngebieten kann es Störungen des Radio- und Fernsehempfangs verursachen. In diesem Fall muss der Benutzer alle notwendigen Maßnahmen ergreifen, die möglicherweise nötig sind, um die Störungen auf eigene Rechnung zu beheben.

 **Warning:**

**ADVERTENCIA**

Este es un producto clase A. El uso de este equipo en áreas residenciales puede causar interferencias nocivas, en cuyo caso, se requerirá que los usuarios tomen cualquier medida necesaria para corregir la interferencia por cuenta propia.

 **Warning:**

**AVISO**

Este dispositivo é um produto Classe A. Operar este equipamento em uma área residencial provavelmente causará interferência prejudicial; neste caso, espera-se que os usuários tomem as medidas necessárias para corrigir a interferência por sua própria conta.

 **Warning:**

**AVVISO**

Questo dispositivo è un prodotto di Classe A. Il funzionamento di questo apparecchio in aree residenziali potrebbe causare interferenze dannose, nel cui caso agli utenti verrà richiesto di adottare tutte le misure necessarie per porre rimedio alle interferenze a proprie spese.

---

## Electrostatic discharge caution statement

 **Electrostatic alert:**

**ELECTROSTATIC ALERT**

ESD can damage electronic circuits. Do not touch electronic hardware unless you wear a grounding wrist strap or other static-dissipating device.

 **Electrostatic alert:**

**ELEKTROSTATIKWARNUNG**

Elektronische Schaltkreise können durch elektrostatische Entladung beschädigt werden. Berühren Sie elektronische Hardware nur, wenn Sie ein Erdungsarmband oder ein anderes Statik ableitendes Medium tragen.

 **Electrostatic alert:**

**ALERTA DE ELECTROESTÁTICA**

Una descarga electroestática puede dañar los circuitos electrónicos. No toque el hardware electrónico a no ser que utilicé una muñequera antiestática u otro dispositivo disipador de estática.

 **Electrostatic alert:**

**ALERTA CONCERNANT LES DÉCHARGES ÉLECTROSTATIQUES**

Une décharge électrostatique (DES) peut endommager les circuits électroniques. Ne touchez pas le matériel électronique, à moins de mettre à votre poignet une bande de mise à la masse ou autre dispositif dissipant l'électricité statique.

 **Electrostatic alert:**

**ALERTA DE ELETROSTÁTICA**

ESD pode danificar circuitos eletrônicos. Não toque em equipamentos eletrônicos a menos que esteja utilizando pulseira de aterramento ou outro dispositivo para dissipação de energia estática.

 **Electrostatic alert:****AVVISO ELETTROSTATICO**

Le scariche elettrostatiche (ESD) possono danneggiare i circuiti elettronici. Non toccare i componenti elettronici senza aver prima indossato un braccialetto antistatico o un altro dispositivo in grado di dissipare l'energia statica.

---

## Laser eye safety danger statement

 **Danger:****Risk of eye injury by laser**

Fiber optic equipment can emit laser or infrared light that can injure your eyes. Never look into an optical fiber or connector port. Always assume that fiber optic cables are connected to a light source.

 **Danger:****DANGER**

Risques de blessure oculaire par lumière laser

L'équipement de fibres optiques peut émettre une lumière laser ou infrarouge nuisible à vos yeux. Ne regardez jamais en direction de fibres optiques ou d'un port connecteur. Supposez toujours que les câbles de fibres optiques sont connectés à une source de lumière.

 **Danger:****GEFAHR**

Risiko einer Augenverletzung durch Laser

Risiko einer Augenverletzung durch Laser Glasfasergeräte können Laserstrahlen oder ultraviolettes Licht aussenden, das Ihre Augen verletzen kann. Schauen Sie nie direkt in einen Glasfaserleiter oder Verbindungsanschluss. Gehen Sie immer davon aus, dass Glasfaserkabel mit einer Lichtquelle verbunden sind.

 **Danger:****PELIGRO**

Riesgo de lesión en los ojos por láser

El equipo de fibra óptica puede emitir una luz láser o infrarroja que dañe sus ojos. Nunca mire un puerto de fibra óptica o conector. Siempre asuma que los cables de fibra óptica están conectados a una fuente de luz.

 **Danger:****PERIGO**

O laser pode causar ferimentos no olho

O equipamento de fibra ótica pode emitir laser ou luz infravermelha que pode causar danos a sua vista. Nunca olhe para dentro da fibra ótica ou da porta do conector. Tenha sempre em mente que os cabos de fibra ótica estão ligados a uma fonte de luz.

 **Danger:**

**PERICOLO**

Rischio di ustioni agli occhi dovute al laser

Le apparecchiature con fibre ottiche possono emettere raggi laser o infrarossi in grado di provocare ferite agli occhi. Non guardare mai all'interno di una porta di connessione o una fibra ottica. Tenere sempre presente che i cavi a fibra ottica sono collegati a una sorgente luminosa.

---

## Laser eye safety connector inspection danger statement

 **Danger:**

**Risk of eye injury**

When you inspect a connector, ensure that light sources are off. The light source used in fiber optic cables can damage your eyes.

 **Danger:**

**DANGER**

Risques de blessure oculaire

Assurez-vous que toutes les sources de lumière ont été désactivées avant de procéder au contrôle d'un connecteur. La source de lumière utilisée dans les câbles de fibres optiques risque de provoquer des lésions oculaires.

 **Danger:**

**GEFAHR**

Verletzungsrisiko der Augen

Achten Sie bei der Kontrolle der Anschlüsse darauf, dass die Lichtquellen abgeschaltet sind. Die für die Glasfaserkabel verwendeten Lichtquellen können Augenschäden hervorrufen.

 **Danger:**

**PELIGRO**

Riesgo de lesiones oculares

Cuando inspeccione un conector, controle que las fuentes de luz estén apagadas. La fuente de luz que utilizan los cables de fibra óptica puede ocasionar daños en la vista.

 **Danger:****PERIGO**

Risco de ferimento nos olhos

Ao inspecionar um conector, verifique se as fontes luminosas estão desligadas. A fonte luminosa usada nos cabos de fibra ótica pode causar danos a seus olhos.

 **Danger:****PERICOLO**

Rischio di lesioni agli occhi

Quando si esamina un connettore, assicurarsi che le sorgenti di luce siano spente. La sorgente di luce utilizzata nei cavi a fibre ottiche potrebbero danneggiare gli occhi.

---

## Connector cleaning safety danger statement

 **Danger:****Risk of eye injury**

When you inspect a connector, ensure that light sources are off. The light source used in fiber optic cables can damage your eyes. To avoid getting debris in your eyes, wear safety glasses when you work with the canned air duster. To avoid eye irritation on contact, wear safety glasses when you work with isopropyl alcohol.

 **Danger:****DANGER**

Risques de blessure oculaire

Assurez-vous que toutes les sources de lumière ont été désactivées avant de procéder au contrôle d'un connecteur. La source de lumière utilisée dans les câbles de fibres optiques risque de provoquer des lésions oculaires. Pour éviter tout risque de projection vers les yeux, portez des lunettes de protection lorsque vous utilisez la bombe dépolvoisierante à air comprimé. Pour éviter tout risque d'irritation oculaire, portez des lunettes de protection lorsque vous utilisez de l'alcool à 90°.

 **Danger:****GEFAHR**

Verletzungsrisiko der Augen

Achten Sie bei der Kontrolle der Anschlüsse darauf, dass die Lichtquellen abgeschaltet sind. Die für die Glasfaserkabel verwendeten Lichtquellen können Augenschäden hervorrufen. Zum Schutz vor Schmutzteilchen tragen Sie eine Schutzbrille, wenn Sie mit einem Pressluft-Spray

arbeiten. Zum Schutz vor Augenirritationen tragen Sie eine Schutzbrille, wenn Sie mit Isopropanol arbeiten.

 **Danger:**

**PELIGRO**

Riesgo de lesiones

Cuando inspeccione un conector, controle que las fuentes de luz estén apagadas. La fuente de luz que utilizan los cables de fibra óptica puede ocasionar daños en la vista. Cuando trabaje con el pulverizador de aire envasado, utilice gafas de seguridad para evitar el ingreso de residuos en los ojos. Utilice gafas de seguridad cuando trabaje con alcohol isopropilo para evitar irritación en los ojos.

 **Danger:**

**PERIGO**

Risco de ferimento nos olhos

Ao inspecionar um conector, verifique se as fontes luminosas estão desligadas. A fonte luminosa usada nos cabos de fibra ótica pode causar danos a seus olhos. Para evitar que seus olhos sejam atingidos por resíduos, use óculos de segurança ao trabalhar com lata de ar comprimido. Para evitar irritação dos olhos, use óculos de segurança ao trabalhar com álcool isopropílico.

 **Danger:**

**PERICOLO**

Rischio di lesioni agli occhi

Quando si esamina un connettore, assicurarsi che le sorgenti di luce siano spente. La sorgente di luce utilizzata nei cavi a fibre ottiche potrebbero danneggiare gli occhi. Per evitare l'accidentale introduzione di detriti negli occhi, indossare gli occhiali di sicurezza quando si lavora con un'impolveratrice ad aria compressa. Per evitare irritazioni oculari da contatto, indossare gli occhiali di sicurezza quando si lavora con alcool isopropilico.

---

## Optical fiber damage warning statement

 **Warning:**

**Risk of equipment damage**

Do not crush fiber optic cable. If fiber optic cable is in the same tray or duct with large, heavy electrical cables, the weight of the electrical cable can damage the fiber optic cable.

 **Warning:**

**AVERTISSEMENT**

Risques d'endommagement de l'équipement

N'exercez pas de pression sur les câbles de fibres optiques. Ne placez pas de câbles de fibres optiques dans la même caisse ou dans le même fourreau que des câbles électriques lourds car leur poids risquerait de les endommager.

 **Warning:**

**WARNUNG**

Risiko von Geräteschäden

Das Glasfaserkabel darf nicht zerdrückt werden. Wenn sich ein Glasfaserkabel zusammen mit großen und schweren Elektrokabeln im gleichen Kabelkanal oder in der gleichen Führung befindet, kann es durch das Gewicht der Elektrokabel beschädigt werden.

 **Warning:**

**ADVERTENCIA**

Riesgo de daños en los equipos

Evite aplastar los cables de fibra óptica. Si el cable de fibra óptica se encuentra en la misma bandeja o conducto que otros cables eléctricos grandes y pesados, puede dañarse.

 **Warning:**

**AVISO**

Risco de danos ao equipamento

Não amasse o cabo de fibra ótica. Se o cabo de fibra ótica estiver na mesma bandeja ou duto com cabos elétricos longos e pesados, ele pode ser danificado pelo peso do cabo elétrico.

 **Warning:**

**Avvertenza**

Rischio di danno all'apparecchio

Non schiacciare o piegare il cavo a fibre ottiche. Se il cavo a fibre ottiche è posizionato in un vassoio o condotto con cavi elettrici pesanti e di grosse dimensioni, esso potrebbe essere danneggiato dal peso dei cavi elettrici.

---

## Optical fiber connector damage warning statement

 **Warning:**

**Risk of equipment damage**

To prevent further contamination, clean fiber optic equipment only when you see evidence of contamination.

To prevent contamination, cover the optical ports of all active devices with a dust cap or optical connector.

To avoid the transfer of oil or other contaminants from your fingers to the end face of the ferrule, handle connectors with care.

 **Warning:**

**AVERTISSEMENT**

Risques d'endommagement de l'équipement

Pour éviter tout risque de nouvelle contamination, nettoyez uniquement le matériel en fibre optique lorsque les preuves de contamination sont avérées.

Pour éviter tout risque de contamination, assurez-vous que tous les ports optiques des périphériques sous tension sont protégés par un capuchon anti-poussière ou par un connecteur optique.

Manipulez les connecteurs avec précaution afin d'éviter toute application d'huile provenant de vos doigts ou d'autres contaminants sur l'extrémité de la ferrule.

 **Warning:**

**WARNUNG**

Risiko von Geräteschäden

Zur Vermeidung weiterer Verunreinigungen reinigen Sie die Glasfaser-Ausrüstung nur dann, wenn sie offensichtlich kontaminiert ist.

Zur Vermeidung von Verunreinigungen schützen Sie die optischen Ports aller aktiven Geräte mit einer Staubkappe oder einem optischen Steckverbinder.

Zur Vermeidung von Verunreinigungen des hinteren Muffenteils durch Öl von den Fingern oder durch andere Kontaminationsstoffe behandeln Sie die Anschlüsse vorsichtig.

 **Warning:**

**ADVERTENCIA**

Riesgo de daños en los equipos

Limpie los equipos de fibra óptica únicamente cuando existan rastros de contaminación para evitar diseminarla aun más.

Para evitar la contaminación, controle que los puertos ópticos de todos los dispositivos activos estén cubiertos con una tapa protectora o un conector óptico.

Maneje los conectores con cuidado para no contaminar la superficie de los casquillos con la grasa de los dedos ni otros contaminantes.



**⚠ Warning:****AVISO**

Risco de danos ao equipamento

Para evitar contaminação futura, limpe o equipamento ótico apenas quando houver evidência de contaminação.

Para evitar a contaminação, verifique se as portas óticas de todos os dispositivos ativos estão cobertas com uma proteção contra pó ou conector ótico.

Para evitar a transferência de óleo ou outro agente contaminador de seus dedos para a extremidade final da ponteira, manuseie os conectores com cuidado.

**⚠ Warning:****Avvertenza**

Rischio di danno all'apparecchio

Per evitare ulteriori contaminazioni, pulire l'apparecchio a fibre ottiche solo in presenza di evidente contaminazione.

Per evitare contaminazioni, assicurarsi che le porte ottiche di tutti i dispositivi attivi siano coperte da un tappo antipolvere o da un connettore ottico.

Per evitare il trasferimento di olio o di altri agenti contaminanti dalle dita alla parte finale della ghiera, maneggiare con cura i connettori.

---

## SFP damage warning statement

**⚠ Warning:****Risk of equipment damage**

SFPs are keyed to prevent incorrect insertion. If the SFP resists pressure, do not force it; turn it over, and reinsert it.

**⚠ Warning:****AVERTISSEMENT**

Risques d'endommagement de l'équipement

Afin d'éviter tout risque d'insertion incorrecte, les modules SFP sont verrouillés. Si vous ne parvenez pas à insérer un module SFP, ne forcez pas. Retournez-le et renouvelez l'opération.

**⚠ Warning:****WARNUNG**

Risiko von Geräteschäden

Die SFPs sind so konstruiert, dass ein falsches Einsetzen verhindert wird. Lässt sich ein SFP auch auf Druck hin nicht einsetzen, versuchen Sie nicht, es gewaltsam einzusetzen, sondern drehen Sie es um, und setzen Sie es erneut ein.

 **Warning:**

**ADVERTENCIA**

Riesgo de daños en los equipos

Los módulos SFP cuentan con cuñas que no permiten insertarlos de forma incorrecta. Si el módulo SFP opone resistencia a la presión, no lo fuerce; gírelo e insértelo nuevamente.

 **Warning:**

**AVISO**

Risco de danos ao equipamento

Os SFPs são chaveados para evitar inserção indevida. Se o SFP resistir à pressão, não o force; inverta e recolque-o.

 **Warning:**

**Avvertenza**

Rischio di danni all'apparecchio

Gli SFP dispongono di chiavi in modo da evitarne l'inserimento errato. Se l'SFP resiste alla pressione, non forzarlo ma capovolgerlo e reinserirlo.

# Glossary

<b>attenuation</b>	The decrease in signal strength in an optical fiber caused by absorption and scattering.
<b>Avaya command line interface (ACLI)</b>	A textual user interface. When you use ACLI, you respond to a prompt by typing a command. After you enter the command, you receive a system response.
<b>bit error rate (BER)</b>	The ratio of the number of bit errors to the total number of bits transmitted in a specific time interval.
<b>cable plant</b>	All the optical elements, such as fiber connectors and splices, between a transmitter and a receiver.
<b>coarse wavelength division multiplexing (CWDM)</b>	A technology that uses multiple optical signals with different wavelengths to simultaneously transmit in the same direction over one fiber, and then separates by wavelength at the distant end.
<b>demultiplexing</b>	The wavelength separation in a wavelength-division multiplexing system. The opposite of multiplexing.
<b>dense wavelength division multiplexing (DWDM)</b>	A technology that uses many optical signals (16 or more) with different wavelengths to simultaneously transmit in the same direction across one fiber, and then separate by wavelength at the distant end.
<b>dispersion</b>	The broadening of input pulses as they travel the length of an optical fiber. The following types of dispersion exist: <ul style="list-style-type: none"><li>• modal dispersion—caused by the many optical path lengths in a multimode fiber</li><li>• chromatic dispersion—caused by the differential delay at various wavelengths in an optical fiber</li><li>• waveguide dispersion—caused by light traveling through both the core and cladding materials in single-mode fibers</li></ul>
<b>gigabit Ethernet (GbE)</b>	Ethernet technology with speeds up to 10 Gbps.
<b>light emitting diode (LED)</b>	A semiconductor diode that emits light when a current passes through it.

<b>media</b>	A substance that transmits data between ports; usually fiber optic cables or category 5 unshielded twisted pair (UTP) copper wires.
<b>metropolitan area network (MAN)</b>	A broadband network that covers an area larger than a Local Area Network.
<b>multimode fiber (MMF)</b>	A fiber with a core diameter larger than the wavelength of light transmitted that you can use to propagate many modes of light. Commonly used with LED sources for low speed and short distance lengths. Typical core sizes (measured in microns) are 50/125, 62.5/125 and 100/140.
<b>multiplexing</b>	Carriage of multiple channels over a single transmission medium; a process where a dedicated circuit is shared by multiple users. Typically, data streams intersperse on a bit or byte basis (time division), or separate by different carrier frequencies (frequency division).
<b>nanometer (nm)</b>	One billionth of a meter ( $10^{-9}$ meter). A unit of measure commonly used to express the wavelengths of light.
<b>single-mode fiber (SMF)</b>	One of the various light waves transmitted in an optical fiber. Each optical signal generates many modes, but in single-mode fiber only one mode is transmitted. Transmission occurs through a small diameter core (approximately 10 micrometers), with a cladding that is 10 times the core diameter. These fibers have a potential bandwidth of 50 to 100 gigahertz (GHz) per kilometer.
<b>Small Form Factor Pluggable (SFP)</b>	A hot-swappable input and output enhancement component used with Avaya products to allow gigabit Ethernet ports to link with other gigabit Ethernet ports over various media types.
<b>unshielded twisted pair (UTP)</b>	A cable with one or more pairs of twisted insulated copper conductors bound in a single plastic sheath.