



# 8520 Series Installation Guide

## Setup and Configuration

9037126-00 Rev AE  
April 2026



Copyright © 2026 Extreme Networks, Inc. All rights reserved.

## Legal Notice

Extreme Networks, Inc. reserves the right to make changes in specifications and other information contained in this document and its website without prior notice. The reader should in all cases consult representatives of Extreme Networks to determine whether any such changes have been made.

The hardware, firmware, software or any specifications described or referred to in this document are subject to change without notice.

## Trademarks

Extreme Networks and the Extreme Networks logo are trademarks or registered trademarks of Extreme Networks, Inc. in the United States and/or other countries.

All other names (including any product names) mentioned in this document are the property of their respective owners and may be trademarks or registered trademarks of their respective companies/owners.

For additional information on Extreme Networks trademarks, see: <https://www.extremenetworks.com/about-extreme-networks/company/legal/trademarks>

## Open Source Declarations

Some software files have been licensed under certain open source or third-party licenses.

End-user license agreements and open source declarations can be found at: <https://www.extremenetworks.com/support/policies/open-source-declaration/>



# Table of Contents

---

|   |           |
|---|-----------|
| Introduction to the Extreme 8520 Installation Guide.....    | vii       |
| Text Conventions.....                                       | vii       |
| Help and Support.....                                       | ix        |
| Subscribe to Product Announcements.....                     | x         |
| Documentation and Training.....                             | x         |
| Open Source Declarations.....                               | x         |
| Training.....   | x         |
| Send Feedback.....  | x         |
| <b>New in this Guide.....</b>                               | <b>12</b> |
| April 2026.....   | 12        |
| <b>Extreme 8520 Overview.....</b>                           | <b>13</b> |
| Extreme OS ONE.....   | 13        |
| Management.....   | 13        |
| Cooling.....  | 14        |
| Power Supplies.....   | 14        |
| Operating Temperatures.....                                 | 15        |
| Feature Licensing.....                                      | 15        |
| 8520-48Y Switch Features.....                               | 15        |
| 8520-48XT Switch Features.....                              | 16        |
| <b>Manage Your Switch.....</b>                              | <b>18</b> |
| Connect to Your Switch.....                                 | 18        |
| Configure and Operate Your Switch.....                      | 18        |
| <b>Fan Modules for Use with Your Switch.....</b>            | <b>20</b> |
| Precautions Specific to Fan Modules.....                    | 20        |
| Fan Modules.....  | 21        |
| <b>Power Supplies for Use with Your Switch.....</b>         | <b>22</b> |
| Precautions Specific to Power Supply Modules.....           | 22        |
| 750 W AC Power Supply.....                                  | 23        |
| 750 W DC Power Supply.....                                  | 24        |
| <b>Site Preparation.....</b>                                | <b>25</b> |
| Plan Your Site.....   | 25        |
| Operating Environment Requirements.....                     | 26        |
| Meet Building and Electrical Codes.....                     | 26        |
| Set Up the Wiring Closet.....                               | 27        |
| Control the Temperature.....                                | 28        |
| Control the Humidity Level.....                             | 29        |
| Protect Your System from ESD (Electrostatic Discharge)..... | 29        |
| Rack Specifications and Recommendations.....                | 29        |
| Mechanical Recommendations for the Rack.....                | 30        |

|  |           |
|--|-----------|
| Ground the Rack.....                                 | 30        |
| Provide Adequate Space for the Rack.....             | 30        |
| Secure the Rack.....                                 | 31        |
| Evaluate and Meet Cable Requirements.....            | 31        |
| Label Cables and Keep Accurate Records.....          | 32        |
| Install Cable.....                                   | 32        |
| Use RJ45 Connector Jackets.....                      | 34        |
| Prevent Radio Frequency Interference (RFI).....      | 35        |
| Meet Power Requirements.....                         | 35        |
| Power Supply Requirements.....                       | 35        |
| Power Cord Requirements.....                         | 36        |
| UPS (Uninterruptible Power Supply) Requirements..... | 36        |
| Follow Applicable Industry Standards.....            | 37        |
| <b>Install Your Switch.....</b>                      | <b>38</b> |
| Safety Considerations for Installation.....          | 39        |
| What You Will Need for the Installation.....         | 39        |
| Attach the Switch to a Rack or Cabinet.....          | 40        |
| Four-Post Rack Mount .....                           | 40        |
| Two-Post Rack Mount.....                             | 44        |
| Install Optional Components.....                     | 46        |
| Pluggable Transceiver Modules.....                   | 46        |
| Optical Cables.....                                  | 46        |
| Breakout cables.....                                 | 46        |
| Install Internal Power Supplies.....                 | 47        |
| Connect Network Interface Cables.....                | 47        |
| Turn on the Switch.....                              | 47        |
| Connect AC Power.....                                | 48        |
| Connect DC Power.....                                | 48        |
| <b>Activate and Verify the Switch.....</b>           | <b>49</b> |
| Connect to a Management Console.....                 | 49        |
| Login for the First Time on Extreme OS ONE .....     | 50        |
| Login for the First Time on Extreme SLX-OS.....      | 50        |
| <b>Remove and Replace Components.....</b>            | <b>52</b> |
| Remove a Switch from a Rack.....                     | 52        |
| Remove a Switch from a Four-Post Rack.....           | 52        |
| Remove a Switch from a Two-Post Rack.....            | 55        |
| Replace Power Supplies.....                          | 55        |
| Power Supply Airflow Direction Requirements.....     | 55        |
| Replace a Power Supply.....                          | 56        |
| Replace Fan Modules.....                             | 62        |
| Fan Airflow Direction Requirements.....              | 62        |
| Replace a Fan Module.....                            | 63        |
| <b>Monitor the Switch.....</b>                       | <b>64</b> |
| System Status LEDs.....                              | 64        |
| 10/100/1000Base-T RJ-45 Management Port LEDs.....    | 65        |
| SFP+/SFP28 Port LEDs for the 8520-48Y.....           | 66        |
| 1G/10G RJ45 Port LEDs for the 8520-48XT.....         | 67        |
| QSFP28 Port LEDs.....                                | 67        |

---

|  |           |
|--|-----------|
| <b>Technical Specifications.....</b>                                       | <b>69</b> |
| Extreme 8520 Technical Specifications.....                                 | 69        |
| Acoustic Noise and Fan Speed.....  | 72        |
| Mean Time Between Failures.....  | 73        |
| Power Specifications.....  | 73        |
| Power Supply Specifications.....   | 73        |
| Power Consumption.....   | 74        |
| Power and Heat Dissipation.....  | 80        |
| 750 W Power Supplies Technical Specifications.....                         | 80        |
| Environmental.....   | 82        |
| Standards.....   | 83        |
| EMI/EMC Standards.....   | 83        |
| Power Cord Requirements for AC-Powered Switches and AC Power Supplies..... | 85        |
| Console Connector Pinouts.....   | 85        |
| <b>Safety Information.....</b>   | <b>88</b> |
| Considerations Before Installing.....                                      | 88        |
| General Safety Precautions.....  | 89        |
| Maintenance Safety.....  | 90        |
| Fiber Optic Ports and Optical Safety.....                                  | 90        |
| GBIC, SFP (Mini-GBIC), QSFP+, XENPAK, and XFP Regulatory Compliance.....   | 91        |
| Cable Routing for LAN Systems.....   | 91        |
| Install Power Supply Units and Connect Power.....                          | 92        |
| Select Power Supply Cords.....   | 93        |
| Battery Notice.....  | 93        |
| Battery Warning - Taiwan.....  | 94        |
| <b>Regulatory Information.....</b>   | <b>95</b> |
| CE statement.....  | 95        |
| EMC Warnings.....  | 96        |
| Taiwan BSMI Warning.....   | 96        |
| China CQC Warning.....   | 96        |
| China and Taiwan: Restriction of Hazardous Substances (ROHS).....          | 96        |
| Canadian requirements.....   | 96        |
| China CCC statement.....   | 97        |
| Australia (RCM).....   | 97        |
| Federal Communications Commission (FCC) Notice.....                        | 97        |
| Germany statement.....   | 98        |
| KCC statement (Republic of Korea).....                                     | 98        |
| Japan (VCCI Class A).....  | 98        |
| Japan power cord .....   | 99        |

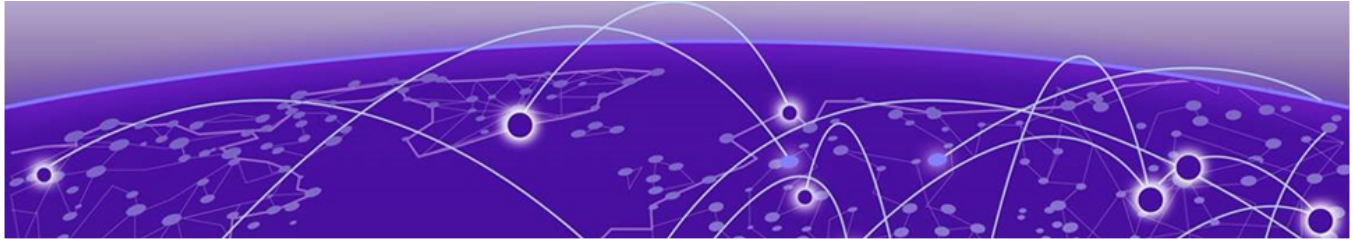

# Abstract

---

This installation guide for the Extreme® 8520 Series switches, revision AE (April 2026), provides intermediate-to-advanced technical guidance for planning, installing, configuring, and maintaining high-density data center switching hardware. It covers the Extreme 8520-48Y and 8520-48XT platforms, detailing system architecture, port capabilities up to 100 GbE, modular fan and power supply options, airflow requirements, and supported operating systems, including Extreme OS ONE and Extreme SLX-OS. The guide presents step-by-step procedures for site preparation, rack mounting, grounding, cabling, power connection (AC and DC), and initial system activation, including first-time login and credential hardening. Usage scenarios focus on large-scale enterprise and service provider data center deployments requiring high throughput, redundancy, and flexible management. The document describes management interfaces such as CLI, REST, NETCONF/YANG, SNMP, and lights-out management, and includes detailed troubleshooting aids such as LED status definitions, power and fan replacement procedures, and POST behavior. Comprehensive technical specifications, environmental limits, regulatory compliance, and safety considerations support accurate deployment planning, operational reliability, and ongoing hardware maintenance for qualified network administrators.

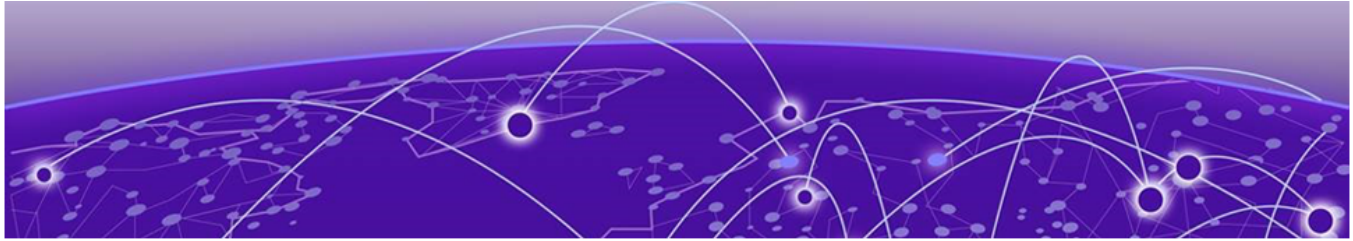

# Introduction to the Extreme 8520 Installation Guide

---

This guide is intended for use by network administrators responsible for installing and setting up network equipment. It assumes a basic working knowledge of:

- Local area networks (LANs)
- Ethernet concepts
- Ethernet switching and bridging concepts
- Routing concepts
- Simple Network Management Protocol (SNMP)
- Basic equipment installation procedures

See the *Extreme OS ONE SR Deployment Guide* and the *Extreme OS ONE Command Reference* for your version of the Extreme OS ONE operating system for information about configuring Extreme Networks switches if you are running Extreme OS ONE.

See the *Extreme SLX-OS User Guide* and the *Extreme SLX-OS Command Reference Guide* for your version of the Extreme SLX-OS operating system for information about configuring Extreme Networks switches if you are running Extreme SLX-OS.



## Note

If the information in an installation note or release note shipped with your Extreme Networks equipment differs from the information in this guide, follow the installation or release note.

Read the following topics to learn about:

- The meanings of text formats used in this document.
- Where you can find additional information and help.
- How to reach us with questions and comments.





## Text Conventions

---

Unless otherwise noted, information in this document applies to all supported environments for the products in question. Exceptions, like command keywords associated with a specific software version, are identified in the text.

When a feature, function, or operation pertains to a specific hardware product, the product name is used. When features, functions, and operations are the same across an entire product family, such as Extreme Networks switches, the product is referred to as *the switch*.

**Table 1: Notes and warnings**

| Icon  | Notice type | Alerts you to..   |
|---|-------------|---|
|  | Tip         | Helpful tips and notices for using the product          |
|  | Note        | Useful information or instructions                      |
|  | Important   | Important features or instructions                      |
|  | Caution     | Risk of personal injury, system damage, or loss of data |
|  | Warning     | Risk of severe personal injury                          |

**Table 2: Text**

| Convention                             | Description   |
|--|---|
| screen displays                        | This typeface indicates command syntax, or represents information as it is displayed on the screen.   |
| The words <i>enter</i> and <i>type</i> | When you see the word <i>enter</i> in this guide, you must type something, and then press the Return or Enter key. Do not press the Return or Enter key when an instruction simply says <i>type</i> .           |
| <b>Key names</b>                       | Key names are written in boldface, for example <b>Ctrl</b> or <b>Esc</b> . If you must press two or more keys simultaneously, the key names are linked with a plus sign (+). Example: Press <b>Ctrl+Alt+Del</b> |
| <i>Words in italicized type</i>        | Italics emphasize a point or denote new terms at the place where they are defined in the text. Italics are also used when referring to publication titles.  |
| <b>NEW!</b>                            | New information. In a PDF, this is searchable text.   |

**Table 3: Command syntax**

| Convention         | Description   |
|--------------------|---|
| <b>bold text</b>   | Bold text indicates command names, keywords, and command options. |
| <i>italic text</i> | Italic text indicates variable content.                           |

**Table 3: Command syntax (continued)**

| Convention                         | Description  |
|------------------------------------|--|
| [ ]                                | Syntax components displayed within square brackets are optional.<br>Default responses to system prompts are enclosed in square brackets.   |
| { <b>x</b>   <b>y</b>   <b>z</b> } | A choice of required parameters is enclosed in curly brackets separated by vertical bars. You must select one of the options.  |
| <b>x</b>   <b>y</b>                | A vertical bar separates mutually exclusive elements.  |
| < >                                | Nonprinting characters, such as passwords, are enclosed in angle brackets.   |
| ...                                | Repeat the previous element, for example, <i>member[member...]</i> .   |
| \                                  | In command examples, the backslash indicates a “soft” line break. When a backslash separates two lines of a command input, enter the entire command at the prompt without the backslash. |

## Help and Support

If you require assistance, contact Extreme Networks using one of the following methods:

### Extreme Portal

Search the GTAC (Global Technical Assistance Center) knowledge base; manage support cases and service contracts; download software; and obtain product licensing, training, and certifications.

### The Hub

A forum for Extreme Networks customers to connect with one another, answer questions, and share ideas and feedback. This community is monitored by Extreme Networks employees, but is not intended to replace specific guidance from GTAC.

### Call GTAC

For immediate support: (800) 998 2408 (toll-free in U.S. and Canada) or 1 (408) 579 2800. For the support phone number in your country, visit [www.extremenetworks.com/support/contact](http://www.extremenetworks.com/support/contact).

Before contacting Extreme Networks for technical support, have the following information ready:

- Your Extreme Networks service contract number, or serial numbers for all involved Extreme Networks products
- A description of the failure
- A description of any actions already taken to resolve the problem
- A description of your network environment (such as layout, cable type, other relevant environmental information)

- Network load at the time of trouble (if known)
- The device history (for example, if you have returned the device before, or if this is a recurring problem)
- Any related RMA (Return Material Authorization) numbers

## Subscribe to Product Announcements

You can subscribe to email notifications for product and software release announcements, Field Notices, and Vulnerability Notices.

1. Go to [The Hub](#).
2. In the list of categories, expand the **Product Announcements** list.
3. Select a product for which you would like to receive notifications.
4. Select **Subscribe**.
5. To select additional products, return to the **Product Announcements** list and repeat steps 3 and 4.

You can modify your product selections or unsubscribe at any time.

## Documentation and Training

---

Find Extreme Networks product information at the following locations:

[Current Product Documentation](#)

[Release Notes](#)

[Hardware and Software Compatibility](#) for Extreme Networks products

[Extreme Optics Compatibility](#)

[Other Resources](#) such as articles, white papers, and case studies

## Open Source Declarations

Some software files have been licensed under certain open source licenses. Information is available on the [Open Source Declaration](#) page.

## Training

Extreme Networks offers product training courses, both online and in person, as well as specialized certifications. For details, visit the [Extreme Networks Training](#) page.

## Send Feedback

---

The User Enablement team at Extreme Networks has made every effort to ensure that this document is accurate, complete, and easy to use. We strive to improve our documentation to help you in your work, so we want to hear from you. We welcome all feedback, but we especially want to know about:

- Content errors, or confusing or conflicting information.
- Improvements that would help you find relevant information.
- Broken links or usability issues.

To send feedback, email us at [Product-Documentation@extremenetworks.com](mailto:Product-Documentation@extremenetworks.com).

Provide as much detail as possible including the publication title, topic heading, and page number (if applicable), along with your comments and suggestions for improvement.

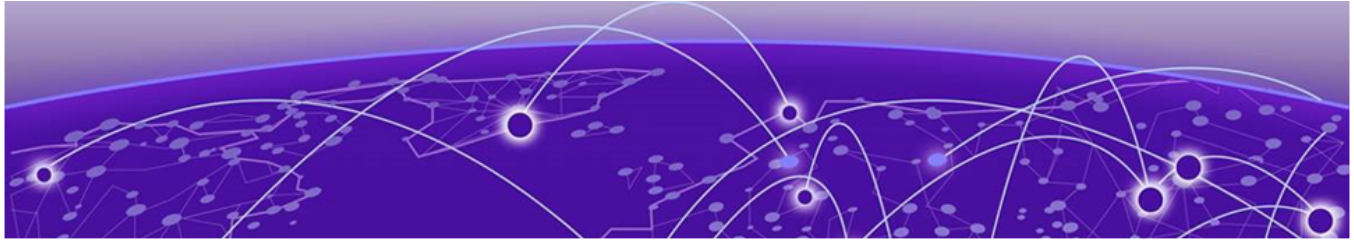

## New in this Guide

---

The following sections describe the recent documentation revisions for this guide. Use this information to locate the latest updates.

### April 2026

---

The following table lists the documentation updates for April, 2026.

| Description                             | Section   |
|---|---|
| Extreme OS ONE operating system support | <a href="#">Introduction to the Extreme 8520 Installation Guide</a> on page vii<br><a href="#">Extreme 8520 Overview</a> on page 13<br><a href="#">Manage Your Switch</a> on page 18<br><a href="#">Login for the First Time on Extreme OS ONE</a> on page 50 |

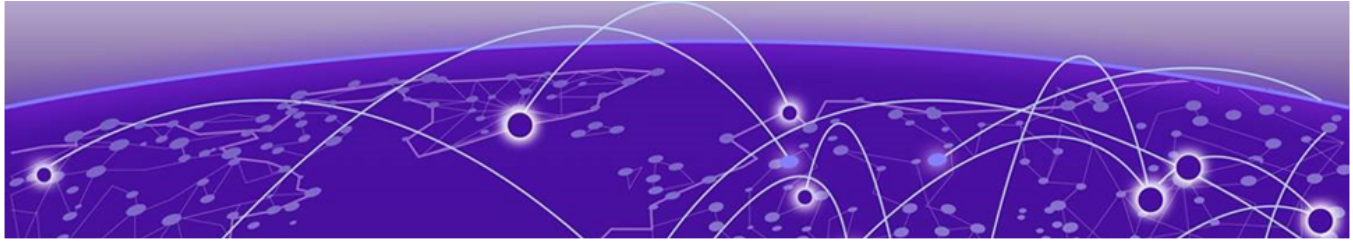

# Extreme 8520 Overview

---

[8520-48Y Switch Features](#) on page 15

[8520-48XT Switch Features](#) on page 16

The Extreme 8520 switches are purpose-built high density 1/10/25/40/100GbE fixed form factor switches designed for large scale data centers at service providers and large enterprise customers. They deliver scalable L2 and L3 resources with advanced features for network monitoring and network virtualization. The Extreme 8520 Series switch offers 48 1/10/25 GbE SFP28 ports and 8 100/40 GbE QSFP28 ports with 32 MB of packet buffer and an overall throughput of 2 Tbps in and out nonblocking switching capacity. SFP and QSFP ports offer a choice of speeds—including 100, 40, 25, 10, or 1 GbE—along with a wide choice of transceivers and cables. Ports can be mixed, offering flexible design options to cost-effectively support demanding data center and service provider environments.

The Extreme 8520 switches run Extreme Networks Extreme OS ONE operating system and the Extreme SLX-OS operating system.

## Extreme OS ONE

---

Extreme OS ONE™ is a cloud-native network operating system (OS) based on a microservices architecture featuring in-service maintainability and is fully API driven for management programmability. Extreme OS ONE is a high-performance network operating system designed for data center, service provider, and enterprise networking environments.

## Management

---

The switch supports connections using the RJ45 serial console port or the Ethernet management port to view and manage the switch configuration. For more information on switch connection methods, see [Manage Your Switch](#). For switch connection details, see [Connect to a Management Console](#) on page 49.

After connecting your switch, use the management functions built into the device to monitor the port status, physical status, and other information to help you analyze

device performance and to accelerate system debugging. The device automatically performs a power-on self-test (POST) each time it is turned on.

**Table 4: Management options for the device**

| Management tool              | Out-of-band support           | In-band support |  |
|------------------------------|-------------------------------|-----------------|--|
| Command line interface (CLI) | Ethernet or serial connection | N/A             | <i>Extreme SLX-OS Command Reference</i>  |
| REST or NETCONF/YANG APIs    | Ethernet connection           | Yes             | <i>Extreme SLX-OS REST API Guide</i><br><i>Extreme SLX-OS RESTCONF Guide</i><br><i>Extreme SLX-OS NETCONF Operations Guide</i><br><i>Extreme SLX-OS YANG Reference Guide</i> |
| Standard SNMP applications   | Ethernet or serial connection | N/A             |  |



**Note**

There is also a Type A USB 2.0 port labeled USB on the front panel that can interface with USB storage devices.

## Cooling

Each switch is cooled by hot-swappable field replaceable fan modules. The switch supports both front-to-back and back-to-front airflow for switch cooling. Switch fans are not responsible for cooling the power supplies; power supplies have integrated cooling fans that operate independently of the switch fan. Fans are ordered separately for base 8520-48Y-8C and 8520-48XT-6C switches. Fans are included with other switches.

For more information about the fan modules used in the switch, see [Fan Modules for Use with Your Switch](#) on page 20.

## Power Supplies

Each switch supports up to two hot-swappable modular AC or DC power supplies that provide enough power for the needs of the switch. Power supplies have integrated cooling fans that operate independently of the switch fans for power supply cooling and are not responsible for cooling the switch. Power supplies are ordered separately for base 8520-48Y-8C and 8520-48XT-6C switches. Power supplies are included with other switches.

For more information about the power supplies used in the switch, see [Power Supplies for Use with Your Switch](#) on page 22.

## Operating Temperatures

The operating temperatures and operating altitude for front-to-back airflow models are 0°C (32°F) to 50°C (122°F) at sea level; 0°C (32°F) to 40°C (104°F) up to 3000 m (10,000 ft).

The operating temperatures and operating altitude for back-to-front airflow models are 0°C (32°F) to 45°C (113°F) at sea level; 0°C (32°F) to 40°C (104°F) up to 3000 m (10,000 ft).

## Feature Licensing

For Extreme SLX-OS licensing for Extreme 8520 switches, refer to the *Extreme SLX-OS Software Licensing Guide*.

**Table 5: Switch License Option**

| Part number     | Description   |
|-----------------|---|
| 8000-PRMR-LIC-P | Extreme 8000 Premier Feature License (Includes Insight Architecture). |

For Extreme OS ONE licensing for Extreme 8520 switches, see the Licensing chapter in the *Extreme OS ONE User Guide* for your version of the Extreme OS ONE operating system.

## 8520-48Y Switch Features

The 8520-48Y Series includes the following models:

### 8520-48Y-8C

The 8520-48Y-8C base switch includes six unpopulated fan module slots and two unpopulated power supply module slots. Fan modules and power supply modules must be ordered separately.

### 8520-48Y-8C-AC-F

The 8520-48Y-8C-AC-F switch includes two AC power supply modules and six fan modules. Airflow for both the fan modules and the powers supply modules is frontto-back.

### 8520-48Y-8C-AC-R

The 8520-48Y-8C-AC-R switch includes two AC power supply modules and six fan modules. Airflow for both the fan modules and the powers supply modules is backto-front.

### 8520-48Y-8C-DC-F

The 8520-48Y-8C-DC-F switch includes two DC power supply modules and six fan modules. Airflow for both the fan modules and the powers supply modules is frontto-back.

### 8520-48Y-8C-DC-R

The 8520-48Y-8C-DC-R switch includes two DC power supply modules and six fan modules. Airflow for both the fan modules and the powers supply modules is backto-front.

The front panel of the switch includes:

- 1 = USB Type A port
- 2 = Serial console port RJ-45
- 3 = 48 x 10/100/1000BASE-T OOB management port
- 4 = System LEDs
- 5 = 1/10/25Gbe SFP28 ports
- 6 = 8 x 40/100Gbe QSFP28 ports

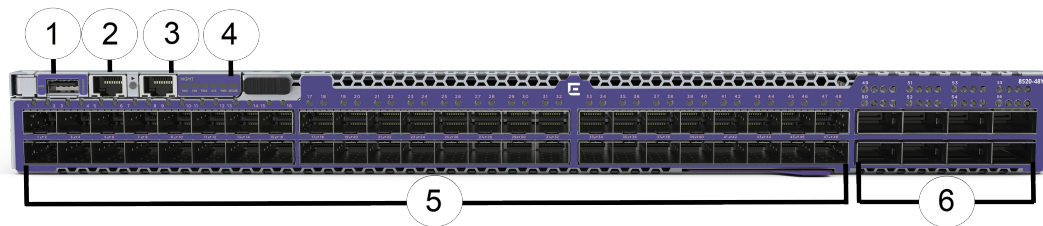

**Figure 1: 8520-48Y Switch Front Panel**

The rear panel of the switch includes:

- 1 = Grounding lug
- 2 = 2 x Power supply slots
- 3 = 6 x Fan modules

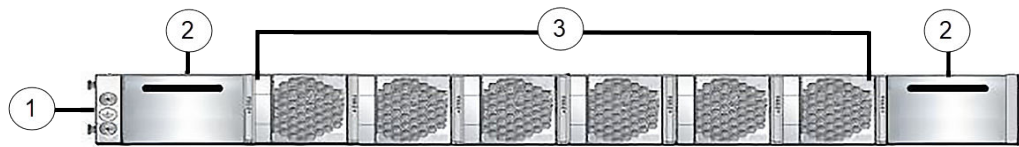

**Figure 2: 8520-48Y Switch Rear Panel**

## 8520-48XT Switch Features

The 8520-48XT Series includes the following models:

### 8520-48XT-6C

The 8520-48XT-6C base switch includes six unpopulated fan module slots and two unpopulated power supply module slots. Fan modules and power supply modules must be ordered separately.

### 8520-48XT-6C-AC-F

The 8520-48XT-6C-AC-F switch includes two AC power supply modules and six fan modules. Airflow for both the fan modules and the powers supply modules is frontto-back.

### 8520-48XT-6C-AC-R

The 8520-48XT-6C-AC-R switch includes two AC power supply modules and six fan modules. Airflow for both the fan modules and the powers supply modules is backto-front.

### 8520-48XT-6C-DC-F

The 8520-48XT-6C-DC-F switch includes two DC power supply modules and six fan modules. Airflow for both the fan modules and the powers supply modules is frontto-back.

### 8520-48XT-6C-DC-R

The 8520-48XT-6C-DC-R switch includes two DC power supply modules and six fan modules. Airflow for both the fan modules and the powers supply modules is back-to-front.

The front panel of the switch includes:

- 1 = 48 x 1/10GbE 10GBaseT RJ-45 ports
- 2 = 6 x 40/100Gbe QSFP28 ports
- 3 = 10/100/1000BASE-T OOB management port
- 4 = USB Type A port
- 5 = Serial console port RJ-45
- 6 = System LEDs

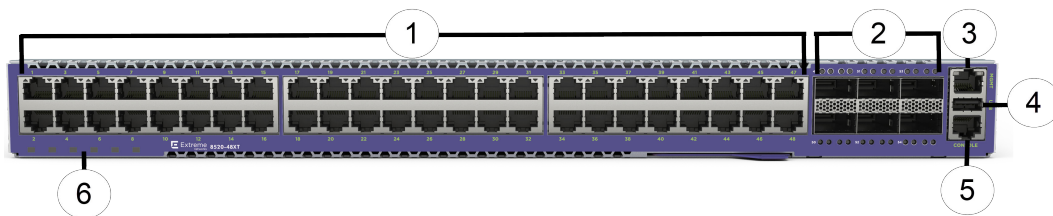

**Figure 3: 8520-48XT Switch Front Panel**

The rear panel of the switch includes:

- 1 = Grounding lug
- 2 = 2 x Power supply slots
- 3 = 6 x Fan modules

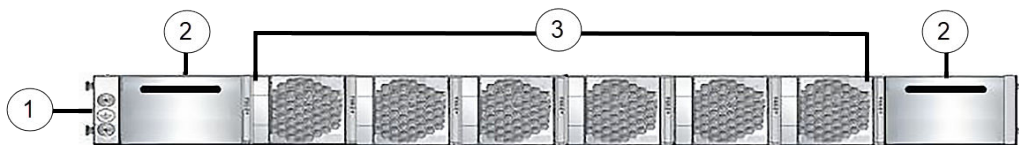

**Figure 4: 8520-48XT Switch Rear Panel**

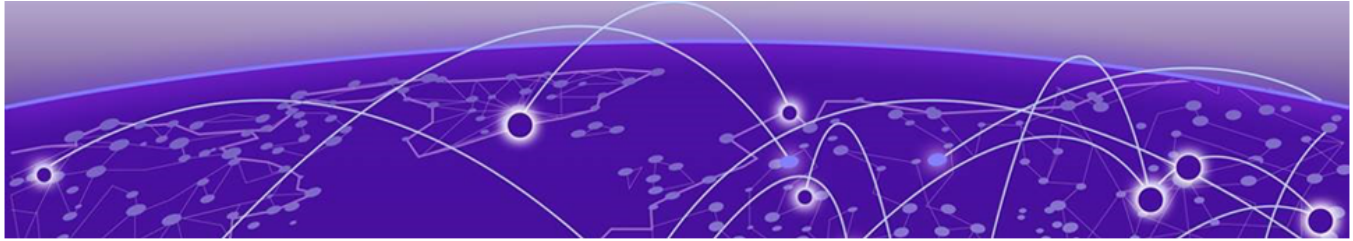

# Manage Your Switch

---

Each switch can be flexibly managed through the CLI for manual configuration, or through REST or NETCONF/YANG APIs, or standard SNMP applications.

## Connect to Your Switch

---

You can use the following methods to connect to the switch.

### **RJ45 serial console port**

Attach an RJ45 to DB9 adapter cable to the RJ45 serial console port on the switch to connect a terminal to manage the switch locally. The RJ45 serial console port is located on the front panel of the switch.

### **Ethernet management port**

Attach an Ethernet cable to the Ethernet management port to connect the system to an out-of-band management network to manage the switch. An Ethernet management port provides dedicated remote access to the switch using TCP/IP. The switch uses an Ethernet management port only for host operation, not for switching or routing.

Alternatively, attach an Ethernet cable directly to the Ethernet management port and a laptop to view and locally manage the switch configuration.

The Ethernet management port is located on the front panel of the switch. It supports 10/100/1000 Mbps speeds.

For switch connection details, see [Connect to a Management Console](#) on page 49.

## Configure and Operate Your Switch

---

The switch supports flexible configuration and operation through the following methods.

### **Web-based GUI or generic command-line interface (CLI)**

The command line interface (CLI) is a powerful tool for managing and configuring switches and network settings. The CLI interface can be accessed through the web-based GUI, or through Telnet, Secure Shell (SSH2), or SNMP using an SNMP manager. The web server must be enabled in the operating system on the switch in order to use the web-based GUI. For more information on Extreme OS ONE, see the *Extreme OS ONE Switching Management Configuration Guide* and the *Extreme OS ONE Switching Command Reference* for your version of the Extreme OS ONE operating system. For more information on Extreme SLX-OS, see the *Extreme SLX-OS Management Configuration Guide* for your version of the Extreme SLX-OS operating system.

## REST API

The REST API (Representational State Transfer Application Programming Interface) can be used for managing and configuring switches through a programmatic interface. It is HTTP-based and allows clients to interact with the server and operational data. It can be used for out-of-band and in-band management through an Ethernet connection. The REST API can be accessed through the RESTCONF interface after it has been enabled in the operating system. Refer to the REST API guide for the switch operating system for more information.

## NETCONF Interface

NETCONF (Network Configuration Protocol) is a protocol used for managing and configuring network devices. NETCONF APIs allow for programmatic access to the switch configuration and operational data. It can be used for in-band management through an Ethernet connection. NETCONF must be enabled in the operating system on the switch and can be accessed using a NETCONF client. Refer to the NETCONF API guide for the switch operating system for more information.

## Lights Out Management (LOM)

The switch contains a baseboard management controller (BMC) for lights-out management (LOM) for remote operations such as reboots, shutdowns, and out-of-band troubleshooting.

## Simple Network Management Protocol (SNMP)

SNMP provides facilities to manage and monitor network resources using agents, managers, the SNMP protocol, and Management Information Bases (MIBs). SNMP must be configured on the switch and accessed through an SNMP manager. For more information on Extreme OS ONE, see the *Extreme OS ONE Switching Management Configuration Guide* and the *Extreme OS ONE Switching Command Reference* for your version of the Extreme OS ONE operating system. For more information on Extreme SLX-OS, see the *Extreme SLX-OS Management Configuration Guide* for your version of the Extreme SLX-OS operating system.

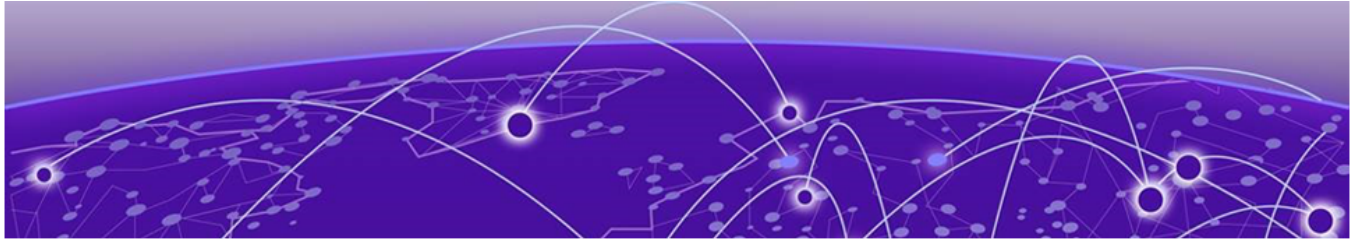

# Fan Modules for Use with Your Switch

---

[Fan Modules](#) on page 21

The Extreme 8520 switch is designed to operate with hot-swappable internal fan modules that provide the cooling needed for the switch to operate. The switch models can include up to six redundant, hot-swappable fan modules. The fan modules in the switch chassis can be removed and replaced without special tools. The switch can continue operating while a fan is being replaced (hot-swap).

Switch fans are not responsible for cooling the power supplies; power supplies have integrated cooling fans that operate independently of the switch fan. The switch supports both front-to-back and back-to-front airflow for switch cooling. Fan module slots are located on the rear panel of the switch.

## Precautions Specific to Fan Modules

---



### Warning

Be careful not to accidentally insert your fingers into the fan tray while removing it from the chassis. The fan may still be spinning at a high speed.



### Caution

Disassembling any part of the power supply and fan assembly voids the warranty and regulatory certifications. There are no user-serviceable parts inside the power supply and fan assembly.



### Caution

Ensure that the airflow direction of the power supply unit matches that of the installed fan tray. The power supplies and fan trays are clearly labeled with either a green arrow with an "E", or an orange arrow with an "I."



### Caution

If you do not install a fan module or a power supply in a slot, you must keep the slot filler panel in place. If you run the chassis with an uncovered slot, the system will overheat.

## Fan Modules

---

Two fan module options, with front-to-back or back-to-front airflow, are supported on the Extreme 8520 switch.

- Part number XN-FAN-001-F provides front-to-back airflow for switch cooling.
- Part number XN-FAN-001-R provides back-to-front airflow for switch cooling.

Fans are ordered separately for base 8520-48Y-8C and 8520-48XT-6C switches. Fans are included with other switches.

For information on installing or replacing a fan module, see [Replace Fan Modules](#) on page 62.

LEDs on the front panel of the switch provide information on the unit's operational status. See [Monitor the Switch](#) on page 64 for details.

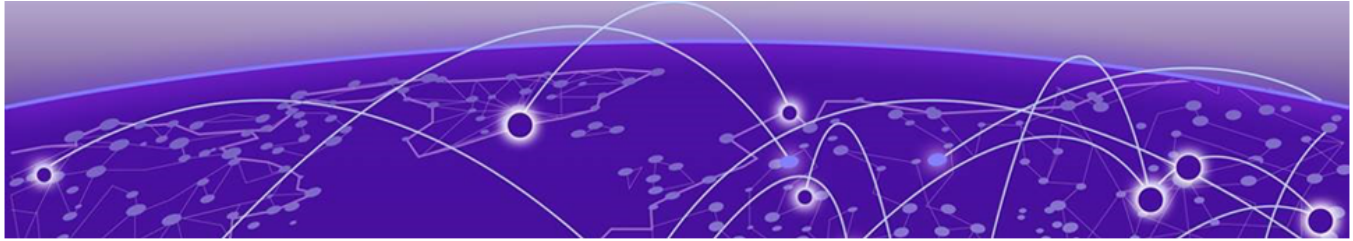

# Power Supplies for Use with Your Switch

---

[750 W AC Power Supply](#) on page 23

[750 W DC Power Supply](#) on page 24

The Extreme 8520 switch is designed to operate with hot-swappable internal AC or DC power supply modules that provide all of the power needed for the switch to operate. You can remove one power supply module without interrupting the switch's operation (hot-swap).



## **Important**

Installed power supplies can be AC or DC , but not a mix of both.

Power supplies have integrated cooling fans that operate independently of the switch fans for power supply cooling and are not responsible for cooling the switch. All installed power supplies must blow air in the same direction and must match the airflow direction of the installed fan modules. Power supply slots are located on the rear panel of the switch.

## Precautions Specific to Power Supply Modules

---



### **Warning**

Make sure you use a power cord displaying the mark of the safety agency that defines the regulations for power cords in your country. The mark is your assurance that the power cord can be used safely with the device.



### **Warning**

If the installation requires a different power cord than the one supplied with the device, make sure you use a power cord displaying the mark of the safety agency that defines the regulations for power cords in your country. The mark is your assurance that the power cord can be used safely with the device.



### **Caution**

Disassembling any part of the power supply and fan assembly voids the warranty and regulatory certifications. There are no user-serviceable parts inside the power supply and fan assembly.

**Caution**

Ensure that the airflow direction of the power supply unit matches that of the installed fan tray. The power supplies and fan trays are clearly labeled with either a green arrow with an "E", or an orange arrow with an "I."

**Caution**

If you do not install a fan module or a power supply in a slot, you must keep the slot filler panel in place. If you run the chassis with an uncovered slot, the system will overheat.

## 750 W AC Power Supply

Two 750 W DC power supply options, with front-to-back or back-to-front airflow, are supported on Extreme 8520.

- Part number XN-ACPWR-750W-F (750 W AC power supply) provides front-to-back airflow for power supply cooling.
- Part number XN-ACPWR-750W-R (750 W AC power supply) provides back-to-front airflow for power supply cooling.

Power supplies are ordered separately for base 8520-48Y-8C and 8520-48XT-6C switches. Power supplies are included with other switches.

The 750 W AC power supply has a (C14) power inlet that requires a (C13) power cord.

**Note**

AC power input cords are not provided with AC power supplies. You can order an appropriate cord from Extreme Networks or from your local supplier. The power cord must meet the requirements listed in [Power Cord Requirements for AC-Powered Switches and AC Power Supplies](#) on page 85.

For information on installing or replacing a power supply, see [Replace Power Supplies](#) on page 55.

The 750 W AC power supply has the status LEDs listed in [Table 6](#). The LEDs are located on the end of the power supply unit, arranged vertically to the left of the power cord receptacle.

**Table 6: 750 W AC Power Supply LED Status Indications**

| Label and Color | Description     | State           | Meaning        |
|-----------------|-----------------|-----------------|----------------|
| ! Amber         | Fault Indicator | On (Solid)      | PSU fault      |
|                 |                 | Off             | No PSU fault   |
| DC (Green)      | DC output Good  | On (solid)      | DC output OK   |
|                 |                 | Off or Blinking | DC output fail |
| AC (Green)      | AC input Good   | On              | AC input OK    |
|                 |                 | Off             | AC input fail  |

## 750 W DC Power Supply

Two 750 W DC power supply options, with front-to-back or back-to-front airflow, are supported on Extreme 8520 switches.

- Part number XN-DCPWR-750W-F (750 W DC power supply) provides front-to-back airflow for power supply cooling.
- Part number XN-DCPWR-750W-R (750 W DC power supply) provides back-to-front airflow for power supply cooling.



### Note

DC power input cords are not provided with DC power supplies. You can order an appropriate cord from Extreme Networks or from your local supplier.

For information on installing or replacing a power supply, see [Replace Power Supplies](#) on page 55.

The 750 W DC power supply has the status LEDs listed in [Table 7](#). The LEDs are located on the end of the power supply unit, arranged vertically to the left of the power cord receptacle.

**Table 7: 750 W DC Power Supply LED Status Indications**

| Label and Color   | Description           | State           | Meaning        |
|-------------------|-----------------------|-----------------|----------------|
| !<br>Amber        | Fault Indicator       | On (Solid)      | PSU fault      |
|                   |                       | Off             | No PSU fault   |
| Out OK<br>(Green) | DC output Good        | On (solid)      | DC output OK   |
|                   |                       | Off or Blinking | DC output fail |
| In OK<br>(Green)  | DC input Good "IN OK" | On              | DC input OK    |
|                   |                       | Off             | DC input fail  |

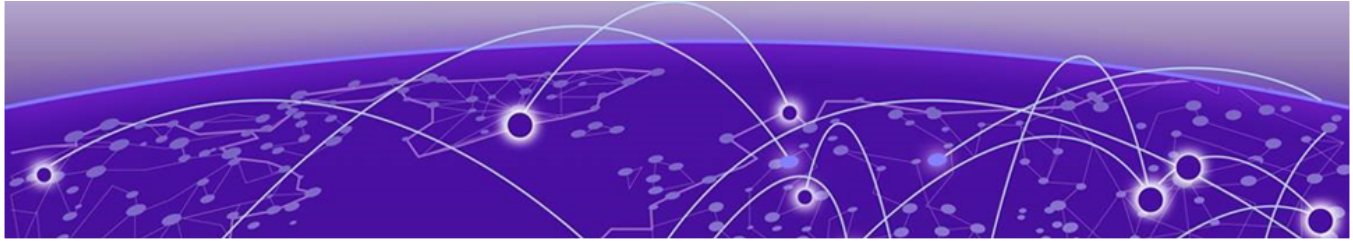

# Site Preparation

---

- [Plan Your Site](#) on page 25
- [Operating Environment Requirements](#) on page 26
- [Rack Specifications and Recommendations](#) on page 29
- [Evaluate and Meet Cable Requirements](#) on page 31
- [Meet Power Requirements](#) on page 35
- [Follow Applicable Industry Standards](#) on page 37

By carefully planning your site, you can maximize the performance of your existing network and ensure that it is ready to migrate to future networking technologies.

The information in this chapter is intended for the system administrator, network equipment technician, network manager, or facilities manager responsible for installing and managing the network hardware. The chapter assumes a working knowledge of local area network (LAN) operations, and a familiarity with communications protocols that are used on interconnected LANs.

Only qualified service personnel should install, maintain, or remove a switch, chassis, or its components. Qualified service personnel have had appropriate technical training and experience that is necessary to be aware of the hazards to which they are exposed when performing a task and of measures to minimize the danger to themselves or other people.



## Note

Before installing or removing any components of the system, and before carrying out any maintenance procedures, read the safety information in the [Technical Specifications](#) on page 69 topic.

## Plan Your Site

---

To install your equipment successfully, you should plan the site carefully. The site planning process has three major parts:

1. Meeting site requirements.

The physical installation site must meet the following requirements for a safe and successful installation:

- Building and electrical code requirements
- Environmental, safety, and thermal requirements for the equipment you plan to install

- Equipment rack requirements
2. Evaluating and meeting cable requirements.

After examining your physical site and verifying that all environment requirements are met, evaluate and compare your existing cable plant with the requirements of the Extreme Networks equipment to determine if you need to install new cables.

3. Meeting power requirements.

To run your equipment safely, you must meet the specific power requirements for each switch and external power supply unit installed in the system.

For power specifications of the switches, see the specific switch listings in [Technical Specifications](#) on page 69.

## Operating Environment Requirements

---

Verify that your site meets all environmental and safety requirements.

Virtually all areas of the United States are regulated by building codes and standards. During the early planning stages of installing or modifying your network, it is important that you develop a thorough understanding of the regulations that pertain to your location and industry.

### Meet Building and Electrical Codes

Building and electrical codes vary depending on your location. Comply with all code specifications when planning your site and installing cable. This section lists resources for obtaining additional information.

For information about major building codes, consult the following organization:

International Code Council (ICC)  
5203 Leesburg Pike  
Falls Church, VA 22041 USA  
[www.iccsafe.org](http://www.iccsafe.org)

The organizations listed in [Table 8](#) are authorities on electrical codes.

**Table 8: Authorities on Electrical Codes**

| Organization   | Address  | Web Site URL   |
|--|--|--|
| National Electrical Code (NEC) Classification (USA only)<br>Recognized authority on safe electrical wiring. Federal, state, and local governments use NEC standards to establish their own laws, ordinances, and codes on wiring specifications. The NEC classification is published by the National Fire Protection Association (NFPA). | NFPA<br>1 Batterymarch Park<br>Quincy, MA 02169<br>USA                 | <a href="http://www.nfpa.org/">www.nfpa.org/</a>     |
| Underwriters' Laboratory (UL)<br>Independent research and testing laboratory. UL evaluates the performance and capability of electrical wiring and equipment to determine whether they meet certain safety standards when properly used. Acceptance is usually indicated by the words "UL Approved" or "UL Listed."                      | UL<br>333 Pfingsten Road<br>Northbrook, IL 60062<br>USA                | <a href="http://www.ul.com">www.ul.com</a>           |
| National Electrical Manufacturing Association (NEMA) (USA only)<br>Organization of electrical product manufacturers. Members develop consensus standards for cables, wiring, and electrical components.  | NEMA<br>1300 N. 17th Street<br>Rosslyn, VA 22209<br>USA                | <a href="http://www.nema.org">www.nema.org</a>       |
| Electronic Components Industry Association (ECIA)<br>Trade association that develops technical standards, disseminates marketing data, and maintains contact with government agencies in matters relating to the electronics industry.   | ECIA<br>111 Alderman Drive<br>Suite 400<br>Alpharetta, GA 30005<br>USA | <a href="http://www.ecianow.org">www.ecianow.org</a> |
| Federal Communications Commission (FCC) (USA only)<br>Commission that regulates all interstate and foreign electrical communication systems that originate in the United States according to the Communications Act of 1934. The FCC regulates all U.S. telephone and cable systems.   | FCC<br>445 12th Street S.W.<br>Washington, DC 20554<br>USA             | <a href="http://www.fcc.gov">www.fcc.gov</a>         |

## Set Up the Wiring Closet

Be aware of the following recommendations for your wiring closet:

- Make sure that your system is easily accessible for installation and service. See [Rack Specifications and Recommendations](#) on page 29 for more information.
- Use appropriate AC or DC power, power distribution, and grounding for your specific installation.

- Use a vinyl floor covering in your wiring closet. (Concrete floors accumulate dust, and carpets can cause static electricity.)
- Prevent unauthorized access to wiring closets by providing door locks. Install the equipment in a secured, enclosed, and restricted access location, ensuring that only qualified service personnel have access to the equipment.
- Provide adequate overhead lighting for easy maintenance.
- Be sure that each wiring closet has a suitable ground. All equipment racks and equipment installed in the closet should be grounded.
- Be sure that all system environmental requirements are met, such as ambient temperature and humidity.

**Note**

Consult an electrical contractor for commercial building and wiring specifications.

## Control the Temperature

Extreme Networks equipment generates a significant amount of heat. It is essential that you provide a temperature-controlled environment for both performance and safety.

Install the equipment only in a temperature- and humidity-controlled indoor area that is free of airborne materials that can conduct electricity. Too much humidity can cause a fire. Too little humidity can produce electrical shock and fire.

Observe these additional thermal recommendations for the location where you plan to install your equipment:

- Ensure that the ventilation in the wiring closet is adequate to maintain a temperature below the maximum operating temperature for the equipment.
- Install a reliable air conditioning and ventilation system.
- Keep the ventilation in the wiring closet running during non-business hours; otherwise, the equipment can overheat.
- Maintain a storage temperature between  $-40^{\circ}\text{C}$  ( $-40^{\circ}\text{F}$ ) and  $70^{\circ}\text{C}$  ( $158^{\circ}\text{F}$ ).

[Table 9](#) summarizes the behavior of Extreme Networks switches when they experience high operating temperatures.

Safeguards are built into all Extreme Networks switches and power supply units to minimize the risk of fire.

**Table 9: Thermal Shutdown and Restart Behavior**

| Switch Model(s) | Behavior   |
|-----------------|--|
| All switches    | <p>When internal system temperatures exceed the thermal shutdown temperature limit (typically about 20°C higher than normal system operating temperatures), the system's power supplies are turned off and the switch shuts down. The system remains in the OFF state until the system has sufficient time to cool and the internal thermal sensor measures a temperature lower than the maximum specified ambient temperature, at which time the system restarts automatically.</p> <p>Alternately, you can restart the system by removing and then restoring all line power to the system. The internal sensor must still measure a system temperature that is lower than the maximum specified ambient temperature, so recovery might not be immediate.</p> |

## Control the Humidity Level

To maximize equipment life, keep operating humidity between 50% and 70% relative humidity (non-condensing) during typical operation.

The equipment can operate between 5% and 95% relative humidity (non-condensing) for short intervals.

## Protect Your System from ESD (Electrostatic Discharge)

Your system must be protected from static electricity or ESD. Take the following measures to ensure optimum system performance:

- Remove materials that can cause electrostatic generation (such as synthetic resins) from the wiring closet.
- Check the appropriateness of floor mats and flooring.
- Connect metal chassis, conduit, and other metals to ground using dedicated grounding lines.
- Use electrostatically safe equipment.

If you are working with pluggable interface modules, wear an ESD-preventive wrist strap and connect the metal end to a grounded equipment rack or other source of ground.

## Rack Specifications and Recommendations

Racks should conform to conventional standards.

In the United States, use EIA Standard RS-310C: Racks, Panels, and Associated Equipment. In countries other than the United States, use IEC Standard 297. In addition,

verify that your rack meets the basic mechanical, space, and earthquake requirements that are described in this section.

## Mechanical Recommendations for the Rack

Use equipment racks that meet the following mechanical recommendations:

- Use an open style, 19-inch rack to facilitate easy maintenance and to provide proper ventilation.
- Use a rack made of steel or aluminum.
- The rack should use the universal mounting rail hole pattern that is identified in IEC Standard 297.
- The rack should have designated earth grounding connections (typically on the base).
- The rack must meet earthquake safety requirements equal to that of the installed chassis.
- The mounting holes should be flush with the rails to accommodate the chassis.
- The rack should support approximately 270 kg (600 lb).

## Ground the Rack

The rack must be properly grounded.

Use a rack grounding kit and a ground conductor that is carried back to earth or to another suitable building ground.

At a minimum, follow these guidelines to ground equipment racks to the earth ground:

- CAD weld appropriate wire terminals to building I-beams or earth ground rods.
- For a DC-powered switch, use a minimum 6 AWG stranded copper wire for grounding.

AC-powered switches do not need separate chassis grounding.

- Position the earth ground as close to the equipment rack as possible to maintain the shortest wiring distance possible.
- Use a ground impedance tester or micro-ohm meter to test the quality of earth ground connection at the chassis. This will ensure good grounding between the chassis, rack, and earth ground.



### Note

Because building codes vary worldwide, consult an electrical contractor to ensure proper equipment grounding for your specific installation.

## Provide Adequate Space for the Rack

Provide enough space in front of and behind the switch so that you can service it easily.

Allow a minimum of 48 inches (122 cm) in front of the rack and 30 inches (76 cm) behind the rack. When using a relay (two-post) rack, provide a minimum of 24 inches (61 cm) of space behind the mounted equipment. Extra room on each side is optional.



### Warning

Extreme Networks switches do not have a switch for turning power to the unit on and off. For systems using an AC power supply, power to the switch is disconnected by removing the wall plug from the electrical outlet.

Be sure that cables and other equipment do not block the switch's air intake or outflow.

Depending on other conditions in the equipment room, it may be possible to install the switches closer to each other; consult your Extreme Networks Customer Support representative for guidance.

## Secure the Rack

The rack should be attached to the wiring closet floor with 9.5 mm (3/8 in) lag screws or equivalent hardware. The floor under the rack should be level within 5 mm (3/16 in). Use a floor-leveling cement compound if necessary or bolt the racks to the floor as shown.

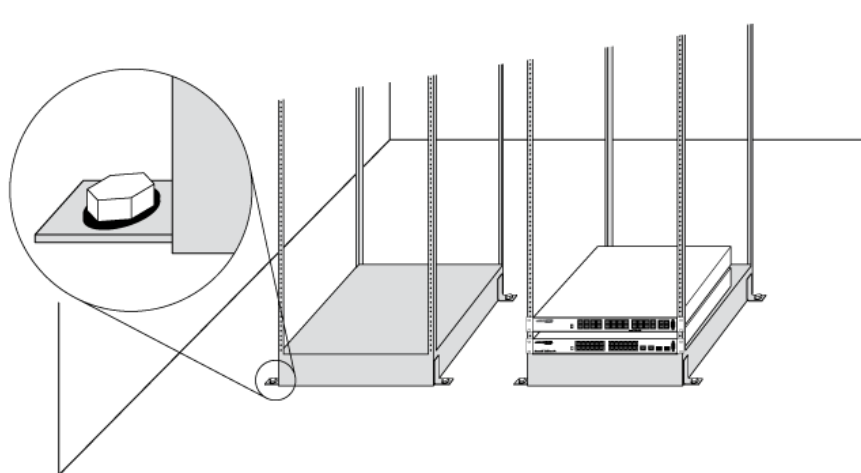

**Figure 5: Properly Secured Rack**

Brace open equipment racks if the channel thickness is less than 6.4 mm (1/4 in).

## Evaluate and Meet Cable Requirements

Use professional consultants for site planning and cabling.

The Building Industry Consulting Service International (BICSI) Registered Communications Distribution Designer (RCDD), which is globally recognized as a standard in site planning and cabling, can be used.

For information, visit [www.bicsi.org](http://www.bicsi.org).

## Label Cables and Keep Accurate Records

A reliable cable labeling system is essential when planning and installing a network.

Keeping accurate records helps you to:

- Relocate devices easily.
- Make changes quickly.
- Isolate faults in the distribution system.
- Locate the opposite end of any cable.
- Know the types of network devices that your cabling infrastructure can support.

Follow these guidelines when setting up a cable labeling system suitable for your installation:

- Identify cables by securely attaching labels to all cable ends.
- Assign a unique block of sequential numbers to the group of cables that run between each pair of wiring closets.
- Assign a unique identification number to each equipment rack.
- Identify all wiring closets by labeling the front panel of your Extreme Networks equipment and other hardware.
- Keep accurate and current cable identification records.
- Post records near each equipment rack. For each cable drop, include information about the cable source, destination, and jumper location.

## Install Cable

When you connect cable to your network equipment, keep the following things in mind.

- Examine cable for cuts, bends, and nicks.
- Support cable using a cable manager that is mounted above connectors to avoid unnecessary weight on the cable bundles.
- Use cable managers to route cable bundles to the left and right of the network equipment to maximize accessibility to the connectors.
- Provide enough slack, approximately 5 to 7.5 cm (2 to 3 in), to provide proper strain relief as shown in [Figure 6](#) on page 33.
- Bundle cable using hook-and-loop straps to avoid injuring cables.
- If you build your own cable, be sure that connectors are properly crimped.
- When installing a patch panel using twisted pair wiring, untwist no more than 2.5 cm (1 in) of the cable to avoid radio frequency (RF) interference.
- Discharge the RJ45 Ethernet cable before plugging it into a port on the switch.



### Caution

Unshielded twisted pair (UTP) cable can build up electrostatic charges when being pulled into a new installation. Before connecting any category 5 UTP cable to the switch, discharge ESD from the cable by plugging the RJ45 connector into a LAN static discharge device or use an equivalent method.

- Use plenum-rated cable when it is necessary for safety and fire rating requirements. Consult your local building codes to determine when it is appropriate to use plenum-rated cable, or refer to IEC standard 850.
- Keep all ports and connectors free of dust.

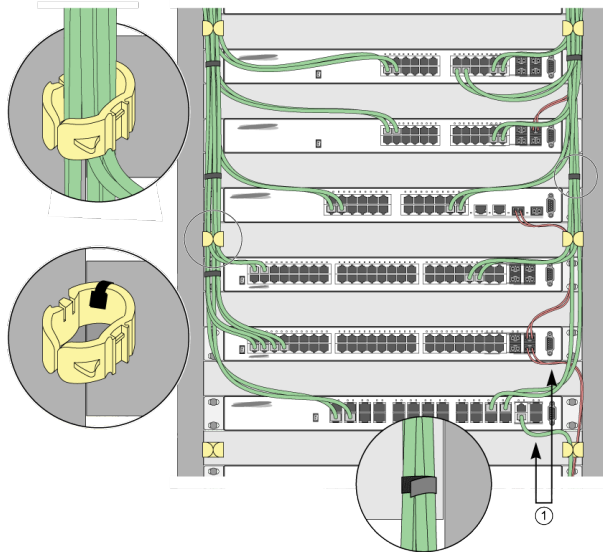

**Figure 6: Properly Installed and Bundled Cable**

1 = Ensure adequate slack and bend radius

#### *Handle Fiber Optic Cable*

Fiber optic cable must be handled carefully during installation.

Every cable has a minimum bend radius, and fibers will be damaged if the cables are bent too sharply. It is also important not to stretch the cable during installation. Ensure that the bend radius for fiber optic cables is equal to at least 5 cm (2 in) for each 90-degree turn as shown in [Figure 7](#).



#### **Note**

Kinks and sharp bends can destroy or impair the cable's ability to convey light pulses accurately from one end of the cable to the other. Use care in dressing the optical fiber cables: provide satisfactory strain relief to support the cable and maintain an adequate bend radius at all cable turns, particularly where the cable connects to the I/O module.

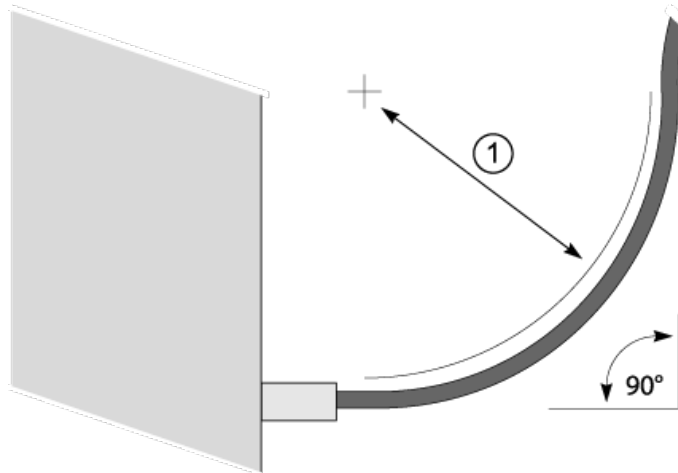

**Figure 7: Bend Radius for Fiber Optic Cable**

1 = Minimum 5 cm (2 in) radius in 90° bend

### Cable Distances and Types

Refer to the [Extreme Optics](#) website for descriptions of optics and cables, as well as a complete list of supported cable lengths, and a list of the cable types that are compatible with your equipment.

### Use RJ45 Connector Jackets

Use RJ45 cable with connector jackets that are flush with the connector or that have connectors with a no-snag feature.

Using cable with jackets that are wider than the connectors can cause:

- Connectors that are not properly aligned with the port.
- Crowded cable installation, which can cause connectors to pop out of the port.

[Figure 8](#) shows examples of recommended and non-recommended connector jacket types.

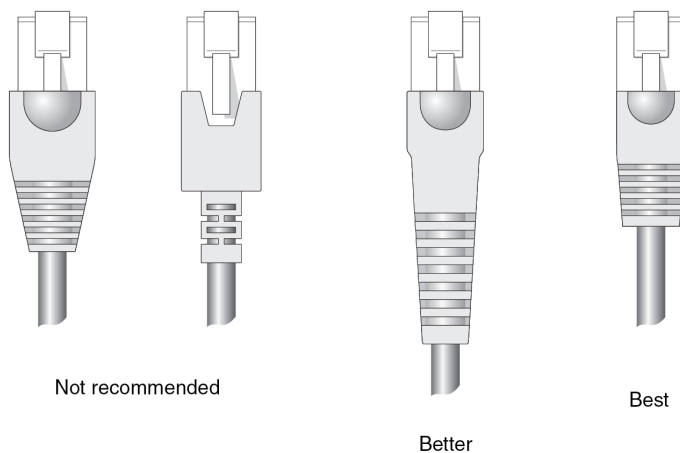

**Figure 8: RJ45 Connector Jacket Types**

SPQ\_001

## Prevent Radio Frequency Interference (RFI)

If you use UTP cabling in an installation, take precautions to avoid radio frequency (RF) interference.

RF interference can cause degradation of signal quality, and, in an Ethernet network environment, can cause excessive collisions, loss of link status, or other physical layer problems that can lead to poor performance or loss of communication.

To prevent RF interference, avoid the following situations:

- Attaching UTP cable to AC power cables
- Routing UTP cable near antennas, such as a ham radio antenna
- Routing UTP cable near equipment that could exhibit RF interference, such as ARC welding equipment
- Routing UTP cable near electrical motors that contain coils
- Routing UTP cable near air conditioner units
- Routing UTP cable near electrical transformers

In areas or applications where these situations cannot be avoided, use fiber optic cabling or shielded twisted pair cabling.

## Meet Power Requirements

---

Observe the following requirements and precautions for powering your hardware.

### Power Supply Requirements

Follow these recommendations when you plan power supply connections for your equipment:

- Place the equipment in an area that accommodates the power consumption and component heat dissipation specifications.
- Be sure that your power supply meets the site DC power or AC power requirements of the network equipment.
- When you connect power to installed equipment, do not make this connection through an extension cord or power strip.
- If your switch includes more than one power supply, connect each power supply to a different, independent power source.

If a power source fails, it will affect only the switch power supply to which it is connected. If all switch power supplies are connected to a single power source, the entire switch is vulnerable to a power source failure.

- In regions that are susceptible to electrical storms, the best practice is to plug your system into a surge suppressor.

For detailed power specifications for your equipment, see [Technical Specifications](#) on page 69.

## Power Cord Requirements

Most Extreme Networks switches do not ship with power cords. Visit [www.extremenetworks.com/product/powercords/](http://www.extremenetworks.com/product/powercords/) for information on selecting and purchasing the correct power cords for use with specific Extreme Networks equipment. The web page provides specifications for power cords in each country so that you can purchase cords locally.

## UPS (Uninterruptible Power Supply) Requirements

A UPS (uninterruptible power supply) is a device that sits between a power supply (such as a wall outlet) and a device (such as a switch) to prevent outages, sags, surges, and bad harmonics from adversely affecting the performance of the device.

A UPS traditionally can perform the following functions:

- Absorb relatively small power surges.
- Smooth out noisy power sources.
- Continue to provide power to equipment during line sags.
- Provide power for a period of time after a blackout has occurred.

In addition, some UPS devices or UPS-plus-software combinations provide the following functions:

- Automatically shut down equipment during long power outages.
- Monitor and log power supply status.
- Display the voltage (current draw) of the equipment.
- Restart equipment after a long power outage.
- Display the voltage currently on the line.
- Provide alarms on certain error conditions.
- Provide short-circuit protection.

### Select a UPS

To determine UPS requirements for your switch, answer these questions:

- What are the amperage requirements?
- What is the longest potential time period that the UPS would be required to supply backup power?
- Where will the UPS be installed?
- What is the maximum transition time that the installation will allow? (See [Provide a Suitable UPS Transition Time](#) on page 37.)



#### Note

Use a UPS that provides online protection.

### Calculate Volt-Amperage Requirements

To determine the size of UPS that you need:

1. Locate the voltage and amperage requirements for each piece of equipment.

These numbers are usually found on a sticker on the back or bottom of your equipment.

2. Multiply the numbers together to get Volt-Amperes (VA):

$VA = \text{Volts} \times \text{Amperes}$

3. Add the VA from all the pieces of equipment together to find the total VA requirement.

To determine the minimum volt-ampere requirements for your UPS, add 30% to the total.

#### *Provide a Suitable UPS Transition Time*

*UPS transition time* is the time required for the UPS to change from providing AC power derived from the utility (or mains) supply to providing AC power derived from the battery backup. UPS transition time is sometimes called *UPS transfer time*.

UPS transition times vary between UPS models and implementations, but shorter transition times are preferred. For Extreme Networks stacking products, a UPS transition time of 20 milliseconds or less ensures optimum performance and minimizes service interruptions.

For high-availability and fault-tolerant installations in which the switches use redundant power supply units (PSUs), ensure that each PSU in a switch is connected to a different UPS and that each UPS is powered by an independent AC supply. This will prevent service interruptions when a power source is lost, or when a UPS unit fails. (Note that a single, appropriately sized UPS can power PSUs in multiple switches. The recommendation is simply that for any given switch, the two PSUs should be connected to different UPS units.)

## Follow Applicable Industry Standards

---

Always follow applicable industry standards.

For more information, see the following ANSI/TIA/EIA standards:

- ANSI/TIA/EIA-568-A—the six subsystems of a structured cabling system
- ANSI/TIA/EIA-569-A—design considerations
- ANSI/TIA/EIA-606—cabling system administration
- ANSI/TIA/EIA-607—commercial building grounding and bonding requirements

You can access these standards at: [or](#) .

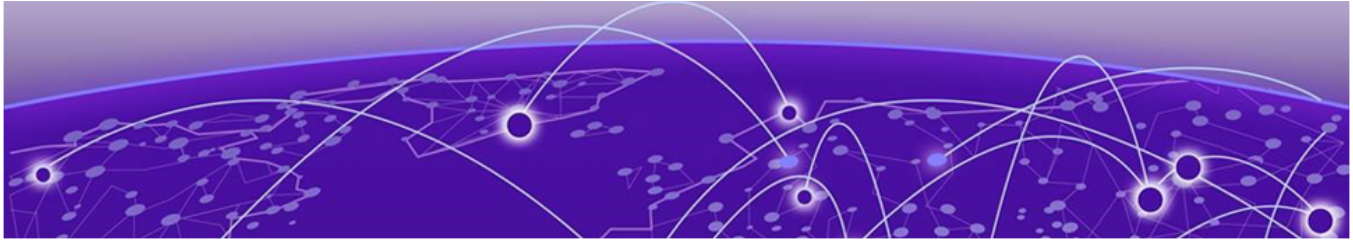

# Install Your Switch

---

- [Safety Considerations for Installation](#) on page 39
- [What You Will Need for the Installation](#) on page 39
- [Attach the Switch to a Rack or Cabinet](#) on page 40
- [Install Optional Components](#) on page 46
- [Install Internal Power Supplies](#) on page 47
- [Connect Network Interface Cables](#) on page 47
- [Turn on the Switch](#) on page 47

Before you attempt to install or remove an Extreme Networks switch, read the precautions in [Safety Considerations for Installation](#) on page 39.

Extreme Networks switches fit into standard 19-inch equipment racks.

A four-post rack-mounting kit is provided with the switch. A two-post kit can be ordered separately.

The installation process includes the following tasks:

**Table 10: Switch Installation Tasks**

| Step | Procedure  | Description   |
|------|--|---|
| 1    | <a href="#">What You Will Need for the Installation</a> on page 39 | Prepare to install the switch   |
| 2    | <a href="#">Attach the Switch to a Rack or Cabinet</a> on page 40  | Install the switch in the rack.   |
| 4    | <a href="#">Install Optional Components</a> on page 46             | Install optional components: optical transceivers and cables.   |
| 5    | <a href="#">Install Internal Power Supplies</a> on page 47         | Install one or two power supplies if your switch does not come with an installed internal power supply.<br><br><b>Note:</b> Be aware of whether the power supply you are installing is AC-powered or a DC-powered. The installation instructions are different depending upon what type of power is used. |
| 6    | <a href="#">Connect Network Interface Cables</a> on page 47        | Connect network interface cables.   |

**Table 10: Switch Installation Tasks (continued)**

| Step | Procedure   | Description   |
|------|---|---|
| 7    | <a href="#">Turn on the Switch</a> on page 47             | Power up the switch.                                  |
| 8    | <a href="#">Activate and Verify the Switch</a> on page 49 | Perform initial network connection and configuration. |

## Safety Considerations for Installation

Read the information in this chapter thoroughly before you attempt to install or remove an Extreme Networks switch.

Ensure that proper ESD (electrostatic discharge) controls are in use before switch maintenance is performed. This includes but is not limited to wrist straps that are grounded to the switch housing and earth grounds.



### Warning

Connect the chassis ground wire **before** you connect any power cables. Disconnect the ground wire **after** you disconnect all power cables.

Take care to load the equipment rack so that it is not top-heavy. Start installing equipment at the bottom of the rack and work up.

Do not cover vents that would restrict airflow.



### Note

See [Safety Information](#) on page 88 for additional safety information. See [Regulatory Information](#) on page 95 for additional information regarding regulatory compliance certifications.

## What You Will Need for the Installation

Ensure that you have followed the guidance in [Site Preparation](#) on page 25, and ensure that you have the appropriate people and tools on hand.

Installing Extreme Networks switches is easiest when there are two people to maneuver the switch and attach mounting hardware.

Provide enough space in front of and behind the switch so that you can service it easily. Ensure that a minimum of 122 cm (48 in) in front of the rack and 76 cm (30 in) behind the rack.

If your switch has internal power supplies, make sure they have the same airflow direction as the fans in the switch.

Check the *Quick Reference Guide* for your switch to see what hardware is provided in the switch packaging. MicoVSP switches do not come with rack-mounting brackets or screws.

You need the following additional tools and equipment. These are not provided with your switch:

- Screwdriver for securing the rack mounting screws.
- #2 Phillips magnetic screwdriver to attach bracket screws that are provided with the switch.
- ESD-preventive wrist strap for installing optional ports at the back of the switch.

## Attach the Switch to a Rack or Cabinet

---

The switch can be attached to a standard 19-inch equipment rack, in either of the following ways:

- Four-post rack, using the mounting kit provided. The kit contains an instruction sheet, along with the following components:
  - Two mounting brackets, known as *inner members* in the instruction sheet. These pieces attach directly to both sides of the switch housing.
  - Two slider assemblies, one for each side of the switch. Each slider assembly consists of an outer piece that is secured to the rack and a sliding rail to which you will attach the corresponding mounting bracket. These pieces are known on the instruction sheet as the *outer member* and *intermediate member*.
  - Mounting ears - Black rack ears with a thumb screw in the middle (2 count)
  - Black mounting ear screws (4 count)
- Two-post rack, using mounting brackets (not provided) to attach the front or the middle of the switch to the posts.

The part number for the four-post mounting kit provided with Extreme 8520 switches is XN-4P-RKMT298. The part number for the two-post mounting kit that is not provided, but can be ordered separately, is XN-2P-RKMT299.

To attach a switch to a four-post rack, a two-post rack, or a cabinet, follow these steps.



### Note

Take care to load the rack so that it is not top-heavy. Start installing equipment at the bottom and work up.

## Four-Post Rack Mount

To attach your switch to a four-post rack, follow these steps:

1. On one side of the switch, locate and remove the two black screws next to the data ports on the switch. Repeat as needed for the opposite side.
2. Using the provided mounting ear screws, attach each of the mounting ears using the holes exposed in the previous step. Ensure that the mounting ears are flush with the faceplate of the switch. See [Figure 9](#).
3. Extend the slider assembly to the fullest extent. Locate the small white release tab on the mounting bracket and push it toward the blue release tab, allowing the mounting bracket to slide the rest of the way off the slider assembly. Repeat this step for the other slider assembly.

4. Attach a mounting bracket to each side of the switch housing, using the screws provided. Ensure that the blue tab is close to the mounting ear and away from the switch. See [Figure 9](#).

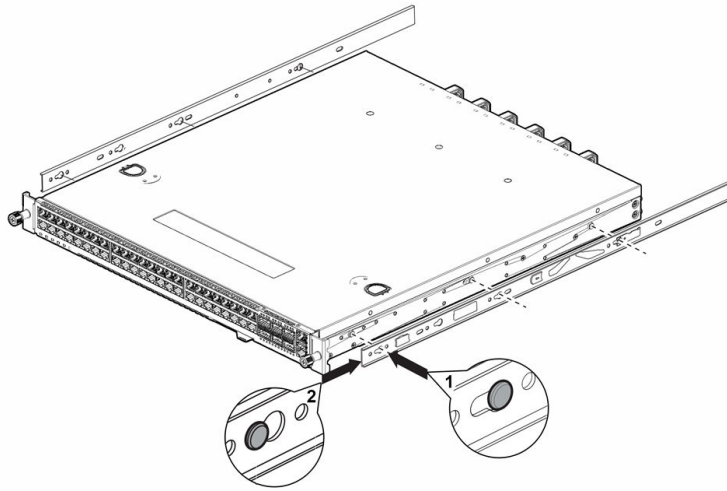

**Figure 9: Attaching a Mounting Bracket to One Side of the Switch Housing**

5. Repeat step 4 to attach the other mounting bracket to the other side of the housing.
6. Attach the slider assemblies to the front and rear rack posts, clicking into place at each end.
  - a. Push the pegs on the front of the slider assembly through the holes in the front rack post, until they snap into place. See [Figure 10](#).

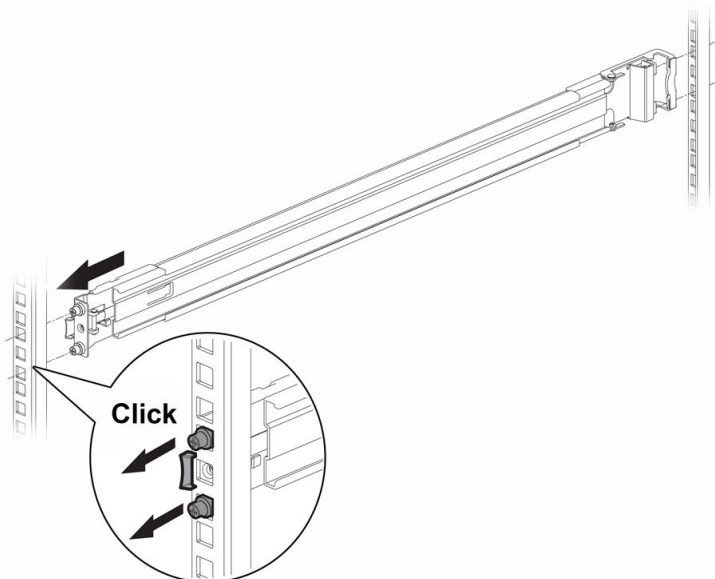

**Figure 10: Attaching the Slider Assembly to the Front Rack Post**

- b. Extend the slider assembly until its rear clamp fits around the rear rack post.

- c. Ensure that the slider assembly is level. If necessary, move it up or down at the rear of the rack.
- d. Snap the rear clamp into place. See [Figure 11](#).

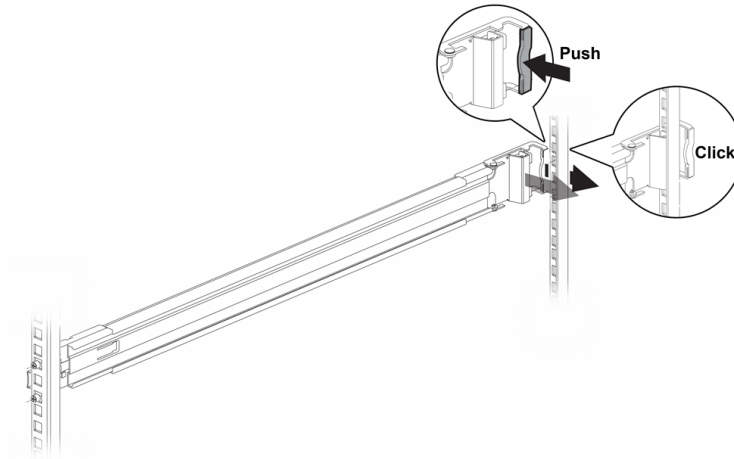

**Figure 11: Attaching the Slider Assembly to the Rear Rack Post**

7. Repeat step 6 to attach the other slider assembly to the front and rear rack posts on the other side.
8. Locate the intermediate rail inside each slider assembly and pull it out to its fullest extent. See [Figure 12](#).

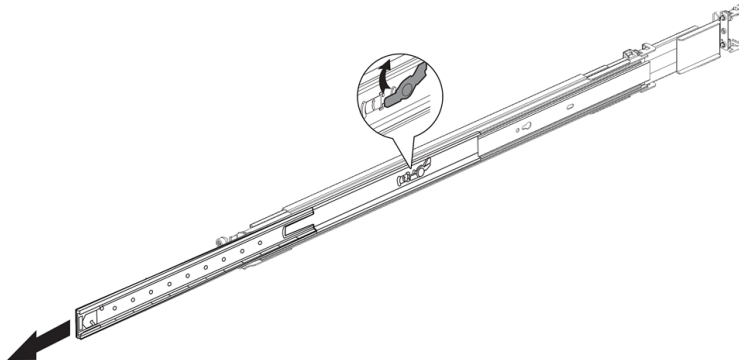

**Figure 12: Extending the Slider Assembly to Fit the Rack**

It remains attached to the slider assembly.

9. Screw the mounting ear thumbscrews into the rack rails to hand tightness
10. Lift the switch into position and insert the mounting brackets into the slider assemblies on both sides.
11. Push the switch in gently until both mounting brackets engage with the sliding rails. See [Figure 13](#).

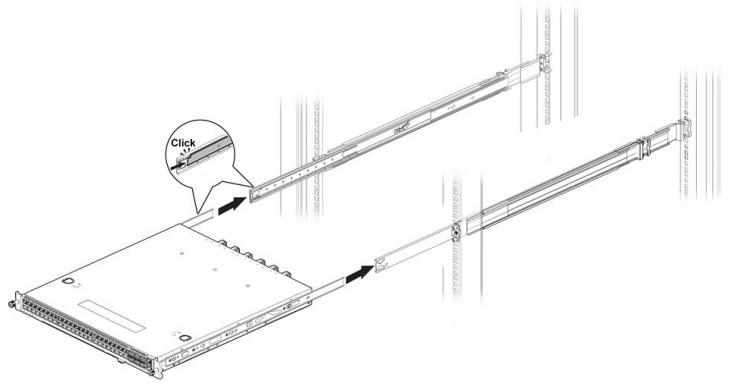

**Figure 13: Engaging the Mounting Brackets with the Rail Assemblies**

12. Release the tabs on both slider assemblies, and carefully push the switch back until it is firmly in place. See [Figure 14](#).

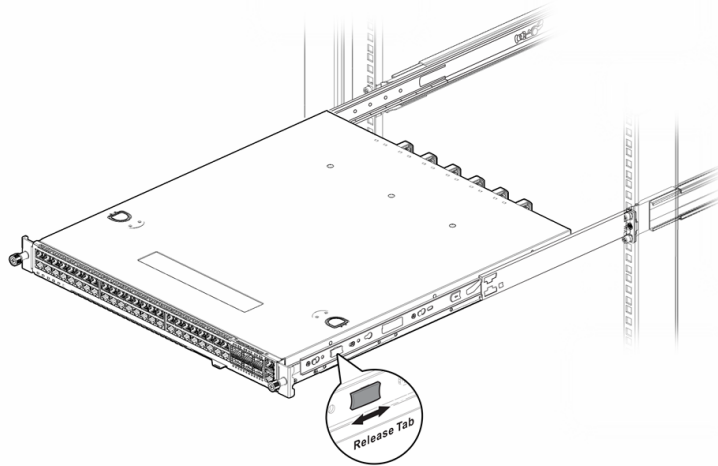

**Figure 14: Pushing the Mounting Brackets into the Rail Assemblies**

13. Screw the mounting ear thumbscrews into the rack rails to hand tightness. The completed assembly is shown in [Figure 15](#).

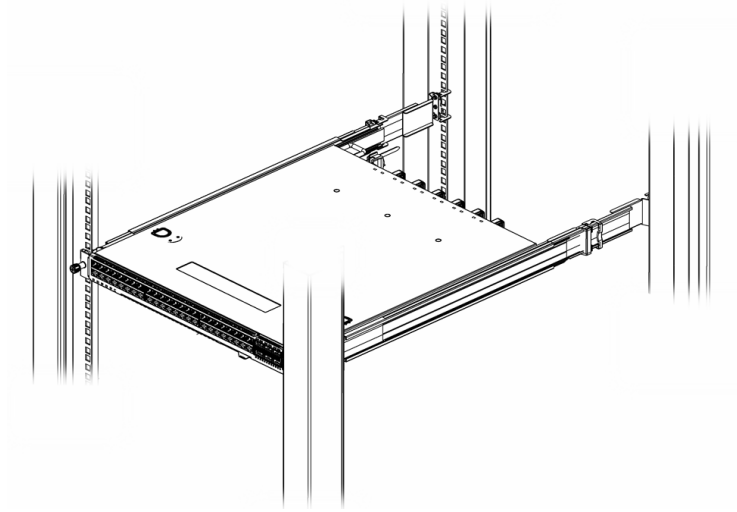

**Figure 15: Completed Installation: Switch in 4-Post Rack**

14. Verify that the switch is leveled and is firmly attached to the rack.

## Two-Post Rack Mount

You can attach the switch to a two-post rack in either of two configurations:

- Flush-mount
- Mid-mount

The side of the switch has different sets of holes for attaching mounting brackets in either configuration.

Mounting brackets for a two-post mount are not included in the box with the switch. However, they can be ordered separately using part number XN-2P-RKMT299.

Use the following instructions to install the switch in a two-post rack.

1. Set a mounting bracket against the switch housing on one side of the switch.

Set the flange (ear) flush with the front of the switch, facing the front, for a flush-mount.

Set the flange (ear) slightly more than halfway between the front and back of the switch, for a mid-mount.

The following figures illustrate how to attach the brackets for two common mounting options.

- [Figure 16](#) shows a flush-mount configuration using a short mounting bracket.
- [Figure 17](#) shows a mid-mount configuration using a short mounting bracket.

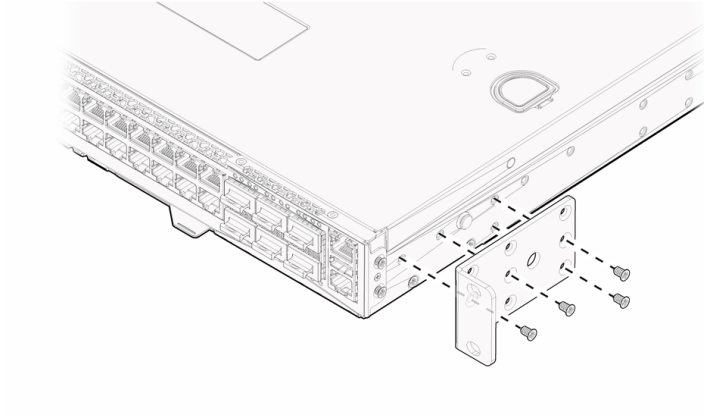

**Figure 16: Flush-Mount: Attaching Short Mounting Brackets**

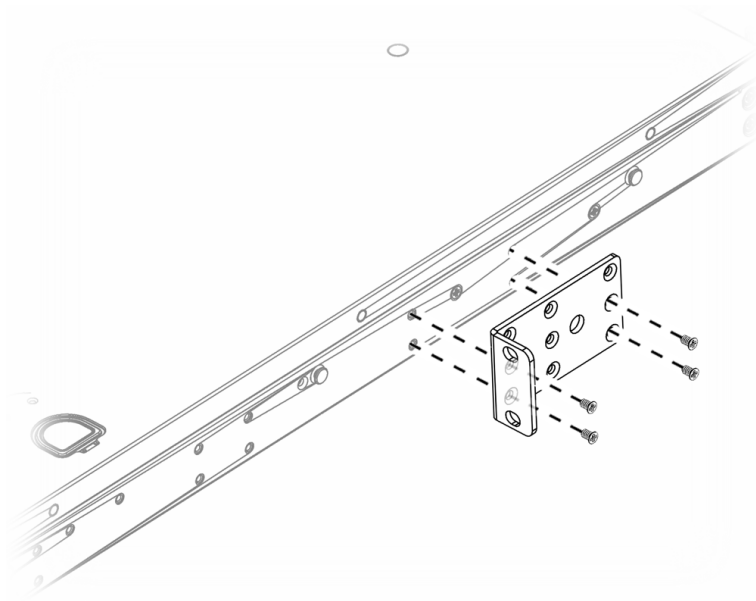

**Figure 17: Mid-Mount: Attaching Short Mounting Brackets**

2. Use the small bracket-mounting screws (provided) to secure the bracket to the switch housing.

If you are using screws other than the screws that are provided, ensure that the threaded length of the screws is within 4 to 5 cm.

3. Repeat step 1 and step 2 to attach the other bracket to the other side of the switch.
4. Secure the mounting bracket flanges to the rack, using screws that are appropriate for the rack. (Rack-mounting screws are not provided.)
5. Verify that the switch is level and is firmly attached to the rack.

After the switch is secured to the rack or cabinet, install optional components using the instructions in [Install Optional Components](#) on page 46.

If the switch comes with installed power supplies, continue to [Install Optional Components](#) on page 46.

If the switch does not have an installed power supply, install one or two power supplies using the instructions in [Install Internal Power Supplies](#) on page 47.

---

## Install Optional Components

---

Extreme Networks switches support the use of pluggable transceivers and cables in the SFP, SFP+, SFP28, QSFP-DD, QSFP+, and QSFP28 formats.

For a list of the optical components supported with Extreme Networks devices, see the [Extreme Optics](#) website.

### Pluggable Transceiver Modules

Extreme Networks offers several optical transceiver modules for transmitting and receiving data over optical fiber rather than through electrical wires.

### Optical Cables

Direct-attach copper and fiber cables provide connections between populated SFP, SFP+, SFP28, QSFP-DD, QSFP+, and QSFP28 ports.

### Breakout cables

The copper breakout cables are terminated with optical connectors and are available in 1m, 3m, 5m, or greater lengths. No additional connectors or cabling are required when using the copper breakout. When using the fiber breakout cables, additional 10Gb optics are required.

For the 8520-48Y switch, interfaces 0/49 and 0/56 support up to 8 10GbE or up to 8 25GbE ports in breakout mode when using the appropriate optics. See the [Extreme Optics](#) website to determine the appropriate optics.

For the 8520-48XT switch, interfaces 0/49 and 0/54 support up to 8 10GbE or up to 8 25GbE ports in breakout mode when using the appropriate optics. See the [Extreme Optics](#) website to determine the appropriate optics.

The first and last ports of the 8520 Series uplinks are capable of breakouts (they are color coded differently too).

- For 8520-48Y models, the 1st and last uplink ports are ports 49 and 56.
- For 8520-48XT models, the 1st and last uplink ports are ports 49 and 54 .

See the [Extreme Optics](#) website to determine the appropriate optics.

## Install Internal Power Supplies

If your switch does not come with an installed power supply, you can install one or two power supplies. All installed power supplies must blow air in the same direction and must match the airflow direction of the installed fan modules.



### Important

Installed power supplies can be AC or DC , but not a mix of both.

- Power supplies with a **red** tab provide front-to-back airflow.
- Power supplies with a **blue** tab provide back-to-front airflow.

For installation instructions, see [Replace Power Supplies](#) on page 55.

## Connect Network Interface Cables

Use the appropriate type of cable to connect the ports of your switch to another switch or router.

| Cable Type | Maximum Distance |
|------------|------------------|
| CAT5E      | 55 meters        |
| CAT6       | 55 meters        |
| CAT6A      | 100 meters       |

Working carefully, one port at a time, do the following:

1. Verify that you have identified the correct cable for the port.
2. Use an alcohol wipe or other appropriate cleaning agent to clean the cable connectors; make sure they are free of dust, oil, and other contaminants.
3. If you are using optical fiber cable, align the transmit (Tx) and receive (Rx) connectors with the correct corresponding connectors on the switch or the I/O module.
4. Press the cable connectors into their mating connectors on the switch or I/O module until the cable connector is firmly seated.
5. Repeat the preceding steps for the remaining cables on this or other switches or I/O modules.
6. Dress and secure the cable bundle to provide appropriate strain relief and protection against bends and kinks.

## Turn on the Switch

Use the following instructions to turn on the switch



### Note

The switch does not have a power button, so connecting the power cable at both ends turns the switch on.

## Connect AC Power

An AC power cord is not included with the AC power supply. You can purchase AC power cords for use in the US and Canada from Extreme Networks or from your local supplier. The cord must meet the requirements listed in [Power Cord Requirements for AC-Powered Switches and AC Power Supplies](#) on page 85.

To turn on the switch, connect one end of the power cord to the AC power input socket on the device and connect the other end to an AC power outlet.



### Note

The grounding connection in the power receptacle and in the power cord properly ground the power supply and extend that grounding to the switch.

If the power supply LEDs do not turn green, refer to [Table 6](#) on page 23 for troubleshooting information.

When the power supply LED has turned green, follow the instructions in [Activate and Verify the Switch](#) on page 49.

## Connect DC Power

Use the following instructions to connect the device to a DC power source.

1. Verify that the DC circuit is de-energized.
2. Verify that the ground wire is connected to the grounding lug on the rear of the switch.

The grounding lug is identified by the international symbol for earth ground:



3. Verify that the DC power input cables are properly connected to the DC power supplies at the rear of the switch.
4. Energize the circuit.

If the power supply LEDs do not turn green, refer to [Table 7](#) on page 24 for troubleshooting information.

If the power supply LEDs do not turn green, refer to [750 W DC Power Supply](#) on page 24 for troubleshooting information.

When the power supply LED has turned green, follow the instructions in [Activate and Verify the Switch](#) on page 49.

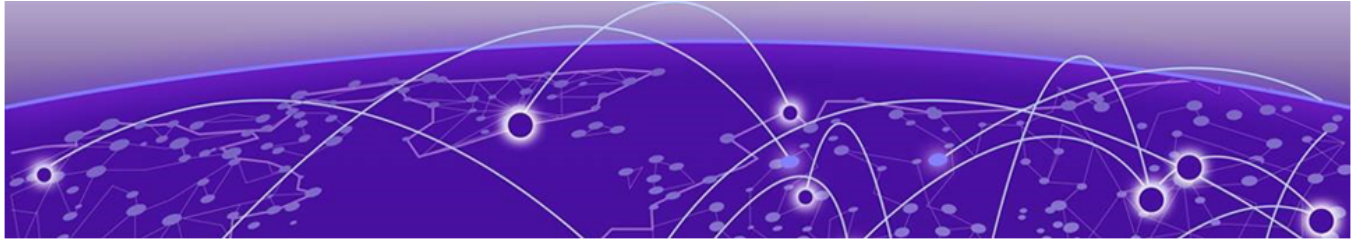

# Activate and Verify the Switch

---

[Connect to a Management Console](#) on page 49

[Login for the First Time on Extreme OS ONE](#) on page 50

[Login for the First Time on Extreme SLX-OS](#) on page 50

After you have installed your Extreme Networks switch in the rack, installed all required and optional components, connected network cables, and powered the switch on, use the instructions in the following topics to configure the software on the switch and prepare it for use.

## Connect to a Management Console

---

The *management console* is a PC or terminal terminal-emulation software that is connected to the serial console port on the switch (an RJ45 jack) by a serial or console cable. The management console is used to monitor and configure the switch locally, using terminal emulator software such as HyperTerminal on a PC, or TERM, Tip, or Kermit in a LINUX environment.

Use the following instructions to connect the switch to a management console.

1. Verify that the switch is powered on by verifying that all power LED indicators on the management and interface ports, power supply and fan modules display a steady green light.
2. Connect the RJ-45 serial cable to the management Ethernet port of the switch.
3. Disable any serial communication programs running on the workstation (such as synchronization programs).
4. Open the terminal emulator software and configure the application with the following default communication protocol settings for the serial console interface.
  - In a Windows environment:
    - Baud rate: 115200
    - Data bits: 8
    - Stop bit: 1
    - Parity: None
    - Flow control: None



### Note

Flow control is not supported on the serial consoles when attached to remote terminal servers and must be disabled to ensure proper operation.

- In a LINUX environment, enter the following string at the prompt:

```
tip /dev/ttyb -115200
```

If ttyb is already in use, use ttya instead and enter the following string at the prompt:

```
tip /dev/ttya -115200
```

## Login for the First Time on Extreme OS ONE

The Extreme 8520 can run Extreme Networks Extreme OS ONE operating system. Extreme OS ONE can be installed using ONIE (Open Network Install Environment), which acts as a bootloader and a lightweight Linux-based provisioning framework that allows vendors and users to install a network operating system over the network or from local media. ONIE, as a Linux-based provisioning framework, relies on Grub at login.

After connecting a management console to the switch, a login prompt displays. The default user ID is `admin` and the default password is `rocks`. You are required to change the default admin password and the Grub `root` user password at the same time. A best practice is to keep the password as `Rocks@123`, but you can choose your own password. To use the same password for the Extreme OS ONE admin user and the Grub `root` user, press **Enter**. For example:

```
Device: login: admin
Password:

*** Please change password for admin account and Grub bootloader now. ***
Use Control-C to exit or press 'Enter' key to proceed.

Changing default password for "admin" and Grub
Current admin password:
Enter new admin password:
Re-type new admin password:
Enter new password for Grub 'root' user login (Press Enter to use admin password for
Grub) : ONE OS 'admin' and Grub 'root' user passwords updated successfully
device#
```

Reboot the device by using the CLI or by powering off the device.

## Login for the First Time on Extreme SLX-OS

The Extreme 8520 switch can run the Extreme SLX-OS operating system. Use the following information to login to Extreme SLX-OS for the first and complete the initial configuration tasks from the management console.

1. Log in to the console using `admin` as the default login name and `password` as the default password.

As login to the device occurs, you are prompted to change the device passwords.

```
Please change passwords for switch default accounts now.  
Use Control-C to exit or press 'Enter' key to proceed.
```

2. Press **Enter** to step through a procedure to change the passwords as shown in the following example. To skip modifying the password, press **Ctrl+C**.

```
Warning: Access to the Root and Factory accounts may be  
required for proper support of the switch. Please ensure the Root  
and Factory passwords are documented in a secure location. Recovery of  
a lost Root or Factory password will result in fabric downtime.  
  
for user - admin  
Changing password for admin  
Enter old password:  
Enter new password:  
Re-type new password:  
passwd: all authentication tokens updated successfully
```

Passwords can be 8 through 40 characters long. They must begin with an alphabetic character. They can include numeric characters, the period (.), and the underscore (\_) only. Passwords are case-sensitive, and they are not displayed when you enter them on the command line. For more information on passwords, refer to *Extreme SLX-OS Security Configuration Guide* for the Extreme 8820 device.

The switch is ready for use.

To configure other switch features, see *Extreme SLX-OS Layer 2 Switching Configuration Guide*.

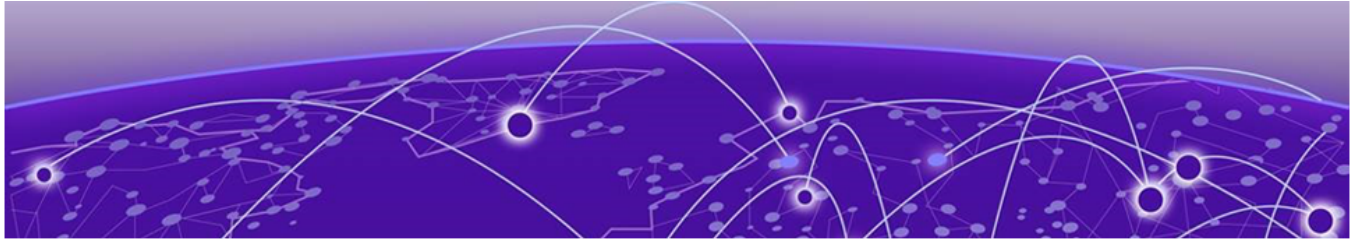

# Remove and Replace Components

---

[Remove a Switch from a Rack](#) on page 52

[Replace Power Supplies](#) on page 55

[Replace Fan Modules](#) on page 62

Use the information in the following topics to remove or replace components.

## Remove a Switch from a Rack

---

These procedures assume that you have attached the device to the rack as described in [Attach the Switch to a Rack or Cabinet](#) on page 40.

### Remove a Switch from a Four-Post Rack

1. Disconnect the device from its power source or sources
2. Remove all cables and transceivers.
3. To remove a device from a four-post rack, do the following:
  - a. Pull the device out of the rack until the slider rails are fully extended, while carefully supporting the weight of the device.
  - b. Push the disconnect latch to release the device after it is fully extended.

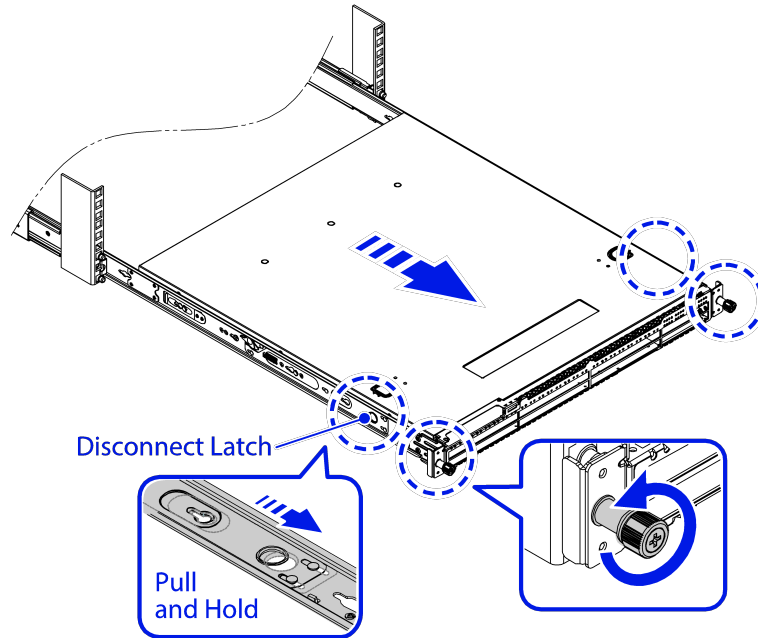
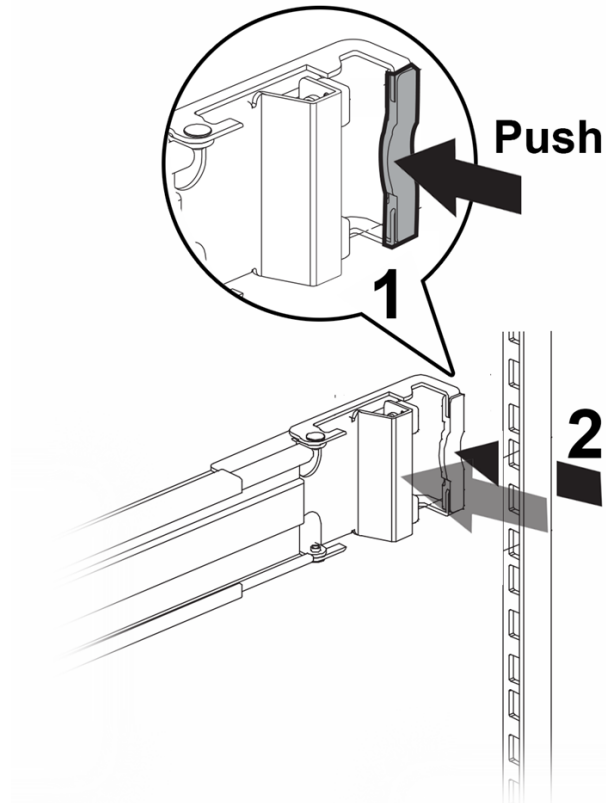

**Figure 18: Disconnect latch for removal**

- c. Disengage the retainers that are connecting the mounting brackets with the sliding rails on both sides.
- d. Carefully slide the device out of the slider assembly and place it on a flat surface.

You can leave the slider assemblies in place. If you want to remove them, continue with the next step.

- e. On one of the slider assemblies, push the rear clamp until it separates from the rear rack post.



**Figure 19: Removing the Slider Assembly: Rear Rack Post**

- f. Release the tab that holds the front of the slider assembly to the front rack post, and pull the pegs out.

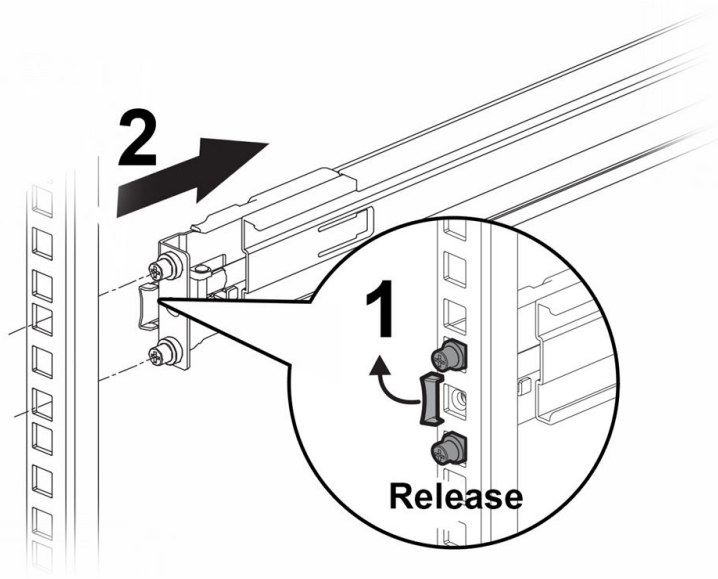

**Figure 20: Removing the Slider Assembly: Front Rack Post**

- g. Repeat step [3.e](#) on page 53 and step [3.f](#) to remove the second slider assembly

## Remove a Switch from a Two-Post Rack

Use the following instructions to remove a switch from a two-post rack.

1. Disconnect the device from its power source or sources, then disconnect the ground, if there is a ground.
2. Remove all cables and transceivers.
3. Unscrew the mounting brackets from the rack while carefully supporting the weight of the device.
4. Tilt the device so that the brackets are clear of the rack posts, and carefully lift it out of the rack.

If the device cannot be tilted (because other equipment is mounted directly above and below), remove one or two mounting brackets from the device and then slide the device out.

If you plan to use the device again later, store it with the mounting brackets attached.

## Replace Power Supplies

For switches with replaceable power supplies, refer to the following information to replace the power supplies. The switches have two power supply slots. Installed power supplies can be AC or DC , but not a mix of both. In a switch with a redundant power configuration, you can replace one power supply without powering down the switch ("hot swapping"). Power supply slots are located on the rear panel of the switch.

Images in this topic might show switches that are not identical to the ones you are using. However, the procedure for replacing a power supply is the same for all Extreme Networks switches.



### Note

Read all of the information in this chapter thoroughly before attempting to replace a power supply.

## Power Supply Airflow Direction Requirements

All installed power supplies must blow air in the same direction and must match the airflow direction of the installed fan modules.

- A power supply with a **red** tab provides front-to-back airflow for power supply cooling. The power supply is labeled **Air Out**.
- A power supply with a **blue** tab provides back-to-front airflow for power supply cooling. The power supply is labeled **Air In**.



### Warning

To prevent an electrical hazard, make sure that the AC power cord is not connected to the power supply before you install the power supply in the power supply slot.

**Warning**

Make sure that the AC power supply circuit is not overloaded. Use proper over-current protection, such as a circuit-breaker, to prevent over-current conditions.

## Replace a Power Supply

Extreme 8520 switches support the following power supplies:

- Part number XN-ACPWR-750W-F (750 W AC power supply) provides front-to- back airflow for power supply cooling.
- Part number XN-ACPWR-750W-R (750 W AC power supply) provides back-to- front airflow for power supply cooling.
- Part number XN-DCPWR-750W-F (750 W DC power supply) provides front-to- back airflow for power supply cooling.
- Part number XN-DCPWR-750W-R (750 W DC power supply) provides back-to- front airflow for power supply cooling.

Use the following instructions to remove and replace a power supply.

### *Remove a Power Supply*

**Caution**

Disconnect the AC power cord from the wall outlet and from the power supply before removing an AC power supply. Ensure that the DC circuit is de-energized before removing a DC power supply.

Use the following instructions to remove a power supply.

1. Attach an ESD-preventive wrist strap to your bare wrist and connect the metal end to an appropriate ground point on the rack.

**Caution**

Power supplies can become very hot during operation. Wear thermal protective gloves when you remove a power supply from an operating switch.

2. Note the orientation and the airflow direction of the installed power supply, and the location of the latching tab on the power supply.
3. Push the latching tab toward the power supply handle and pull outward on the handle to disengage the power supply internal connectors.

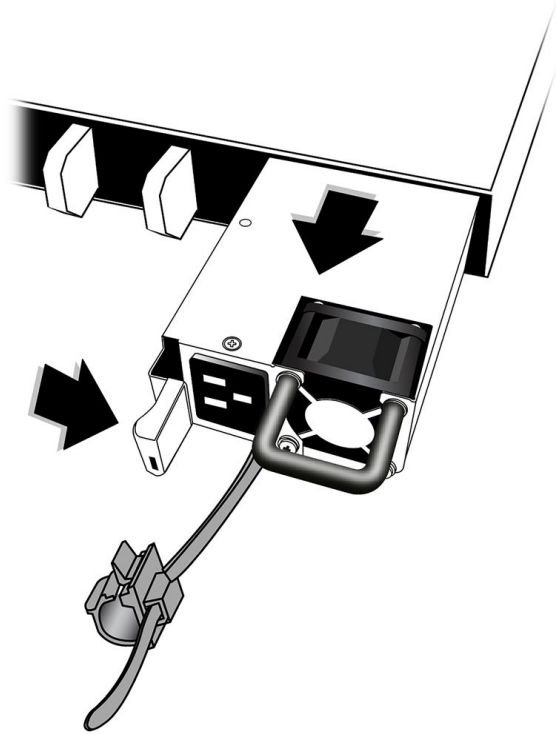

**Figure 21: Remove a Power Supply**



**Note**

If you are not installing a replacement power supply, install a cover over the unoccupied power supply bay. Unoccupied bays must always be covered to maintain proper system ventilation and EMI levels.

*Replace or Install a Power Supply*

Use the following instructions to replace or install a power supply.

1. Attach an ESD-preventive wrist strap to your bare wrist and connect the metal end to an appropriate ground point on the rack.
2. If necessary, remove a blank panel from the back of the switch.
3. Ensure that the orientation of the power supply is correct, and that the new power supply's airflow direction (front-to-back or back-to-front) is compatible with the installed fan modules and any other installed power supplies.
4. Carefully slide the power supply all the way into the power supply slot.

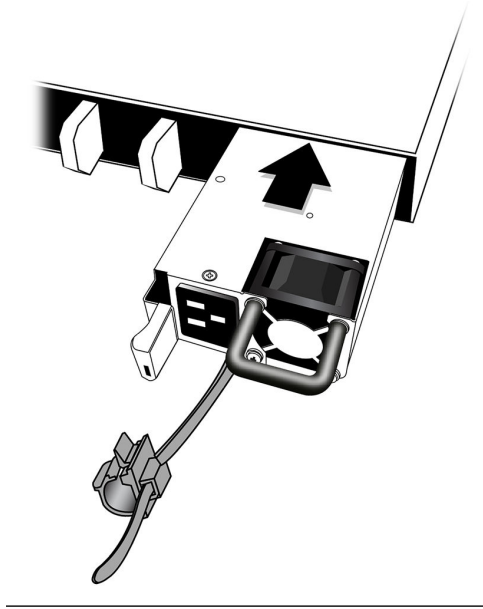

**Figure 22: Install a Power Supply**

5. Push the power supply in until the latch snaps into place.

Do not slam the power supply into the switch.



**Note**

Be sure to install a cover over any unoccupied power supply slots. Unoccupied power supply slots must always be covered to maintain proper system ventilation and EMI levels.

To install or replace a second power supply repeat this procedure.

- After installing an AC power supply, connect the power cord to the power supply and to a grounded AC power outlet.



**Warning**

Always make sure that the source outlet is properly grounded before plugging the AC power cord into the AC power supply.

If the power supply is equipped with a power cord retainer, use the retainer to secure the power cord to the power supply.

*Connect an AC Power Supply to an AC Power Outlet Using the Retainer*

1. Connect the AC power cord.
  - a. If necessary, slide the plastic cord retainer farther away from the back of the switch.
  - b. Connect the AC power cord to the input connector.
  - c. Open the clip and slip it over the barrel of the connector.

The diagram below - Power Supply with Power Cord and Retainer Attached shows the power supply with the power cord and retainer in place.

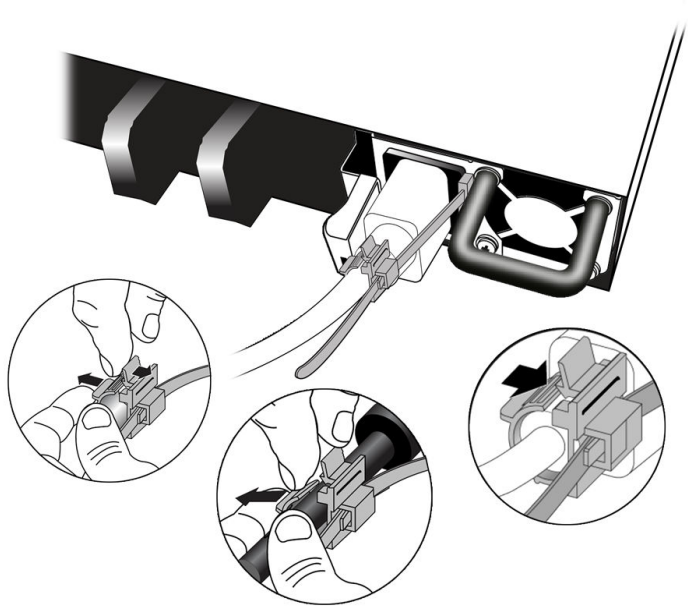

**Figure 23: Power Supply with Power Cord and Retainer Attached**

- d. Snap the clip firmly around the connector.
2. Connect the other end of the power cord to an AC power outlet.



**Note**

Always make sure that the source outlet is properly grounded before plugging the AC power cord into the AC power supply.

Leave the ESD strap permanently connected to the rack, so that the strap is always available when you need to handle ESD-sensitive components.

- After installing a DC power supply, ground the power supply and connect the power supply to the power source.



**Warning**

Connect the chassis ground wire before you connect any power cables.

*Connect a DC Power Supply to a DC Power Source*

After installing the DC power supply, connect it to the DC power source with either cable wires or a power supply cable.

### Required Tools and Materials for Installing a DC Power Supply

You need the following tools and materials to connect a DC power supply to the source voltage.

- #6 AWG copper cable for grounding the power supply and connecting the power supply to the DC power source. (red and black grounding cables are included with the power supply):
  - Red for the -48 V connection (-)
  - Black for the -48 V RTN connection (+)
  - Green or green with yellow stripe for the ground connection
- Connection hardware appropriate to the installation site:
  - Hardware for connecting the power wires to the DC source
  - Hardware for connecting the ground wire to the site grounding point
- Stripping tool
- #1 cross-head (Phillips) screwdriver
- ESD-preventive wrist strap
- Thermal protective gloves (for removal of a warm power supply)

### Prepare the Cables for a DC Power Supply

You need two cable wires for each installed DC power supply: one DC power input cable, which is provided, and a grounding cable. As a best practice, each cable has differently colored insulation, as described in [Required Tools and Materials for Installing a DC Power Supply](#).

To prepare the cable wires, follow these steps:

1. Strip 6 mm (0.25 inch) of insulation from one end of the cable wire, on each cable wire, if necessary.
2. Repeat step 1 for the other cable wire.

### Connect the Ground Wire to a DC Power Supply

Follow these steps to connect the ground wire to a DC power supply.



#### Warning

Be sure to connect the chassis ground wire before you connect any power cables.



#### Warning

Be sure to disconnect the ground wire after you disconnect all power cables.

1. Verify that the DC circuit is de-energized.
2. Attach an ESD-preventive wrist strap to your bare wrist and connect metal end to an appropriate ground point on the rack.
3. Connect the ground wire to the grounding point on the power supply, which is labeled GND.

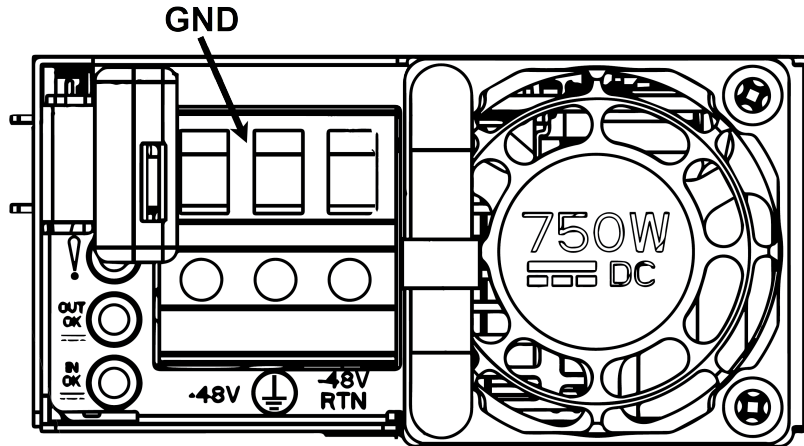

**Figure 24: Front view of the DC power supply**

Directly beneath the grounding point, you will see the international symbol for earth ground –  – on the body of the switch.

- a. Attach ring lug to the 6 AWG ground wire.
- b. Secure the ring lug with a 5mm hex socket and tighten.
- c. Gently tug the ground wire to make sure it is fastened securely.
4. Connect the other end of the wire to a known reliable earth ground point at your site.

#### Connect a DC Power Supply to the Source Voltage



#### Warning

Always make sure that the DC circuit is de-energized before connecting or disconnecting the DC power cables on the DC power supply.



#### Caution

Provide proper connection and strain relief on the DC power cables in accordance with all local and national electrical codes.

The DC power connection at your facility must be made by a qualified electrician.

Use these instructions to connect a power supply cable to the DC power supply:

1. Verify that the DC circuit is de-energized.
2. Attach an ESD-preventive wrist strap to your bare wrist and connect the metal end to an appropriate ground point on the rack.
3. Plug the connector that contains the negative (V+DC) and positive (V-DC) wires to the power supply.

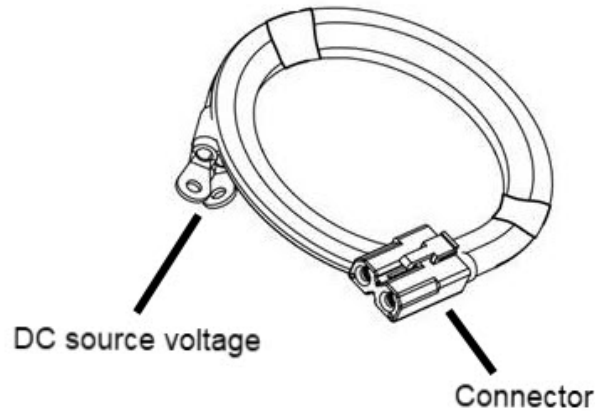

4. Connect the cables to the DC source voltage, using hardware appropriate to the installation site and following local and national electrical codes.

Power up to the switch. See [Turn on the Switch](#) on page 47 for more information.

Leave the ESD strap permanently connected to the rack, so that the strap is always available when you need to handle ESD-sensitive components.

## Replace Fan Modules

For switches with replaceable fan modules, refer to the following information to replace the fan modules. You can replace fan modules as needed while the switch is operating ("hot swapping"). Fan module slots are located on the rear panel of the switch.

Do not operate a chassis for more than a few minutes with a missing fan module. To ensure internal chassis air pressure is maintained and to avoid loss of traffic due to modules overheating and shutting down, leave a failed fan module installed until you have a replacement.

Images in this topic might show switches that are not identical to the ones you are using. However, the procedure for replacing a fan module is the same for all Extreme Networks switches.



### Note

Read all of the information in this chapter thoroughly before attempting to replace a fan module.

## Fan Airflow Direction Requirements

All installed fan modules must blow air in the same direction and must match the airflow direction of the installed power supplies. Before you begin, have the replacement fan module on hand so that you can complete the replacement promptly. The switch can overheat if left without adequate cooling for an extended time.

- Fan modules with a **red** tab provide front-to-back airflow and are labeled **Air Out**.

- Fan modules with a **blue** tab provide back-to-front airflow and are labeled **Air In**.

**Note**

The operating-system software cannot display the airflow direction.

## Replace a Fan Module

Extreme 8520 switches support the following fan modules:

- Part number XN-FAN-001-F provides front-to-back airflow for switch cooling.
- Part number XN-FAN-001-R provides back-to-front airflow for switch cooling.

Use the following instructions to remove and replace a fan module in the switch.

### *Remove a Fan Module*

Use the following instructions to remove a fan module.

1. Gently pull the tab (labeled **Air Out** or **Air In**) on the end of the fan module.

The fan module is held in place by spring clips. As you pull, the clips disengage and the fan stops.

2. Slide the fan module out of the switch and set it aside.

### *Install a Fan Module*

Use the following instructions to install a fan module.

1. Verify that the airflow direction on the replacement fan module matches that of the installed power supplies and any fan modules.

Fan modules with a **red** tab provide front-to-back airflow and are labeled **Air Out**.

Fan modules with a **blue** tab provide back-to-front airflow and are labeled **Air In**.

2. Carefully slide the replacement fan module into the switch.

**Note**

Do not force the installation. If the fan assembly does not slide in easily, ensure that it is correctly oriented before continuing.

Push until the fan module snaps into place. The fan automatically starts to operate.

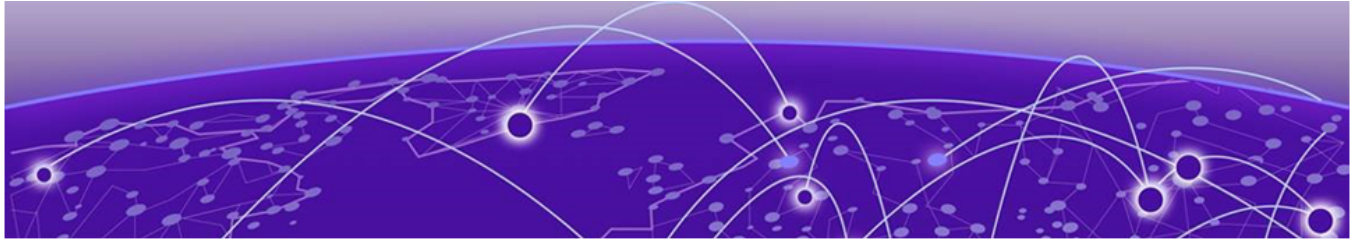

# Monitor the Switch

[System Status LEDs](#) on page 64

[10/100/1000Base-T RJ-45 Management Port LEDs](#) on page 65

[SFP+/SFP28 Port LEDs for the 8520-48Y](#) on page 66

[1G/10G RJ45 Port LEDs for the 8520-48XT](#) on page 67

[QSFP28 Port LEDs](#) on page 67

The following topics help you monitor the status of the switch as it is running.

## System Status LEDs

System status LEDs are located on the front of the switch. The following table describes the colors and the states for the LEDs.

**Table 11: System Status LEDs**

| LED        | Color/State    | Description  |
|------------|----------------|--|
| Power      | Off            | No power; some power rails are dropping below specification.                     |
|            | Green          | Valid power. All monitored voltages are nominal.                                 |
| System     | Off            | Boot failed.   |
|            | Green          | Operational.   |
|            | Blinking amber | Booting.   |
|            | Amber          | Fault.   |
| Fan Status | Off            | No power.  |
|            | Green          | Fan is operational.  |
|            | Amber          | Fan failure.   |
| PSU Status | Off            | No power.  |
|            | Green          | Power on. Main and Standby output enabled with no PSU warning or fault detected. |
|            | Blinking amber | Warning. Power supply warning detected.  |
|            | Amber          | Fault. Power supply fault.   |

**Table 11: System Status LEDs (continued)**

| LED    | Color/State                       | Description  |
|--------|-----------------------------------|--|
| Secure | Off                               | CeC1712 is booting up or fault. CeC1712 is performing the initial load (decrypt, validate, load) of its own code, prior to authenticating images. Or the CeC1712 was unable to decrypt, validate and load its own image. |
|        | Slow blinking blue (1 Hz)         | CeC1712 is authenticating or updating images. CeC1712 is currently authenticating or copying golden image to primary.  |
|        | Fast blinking blue (4 Hz)         | CeC1712 authentication failed. Neither primary nor golden image successfully validated.  |
|        | Very slow blinking blue (0.25 Hz) | Bypass authentication. Bypassing authentication for test or development only.  |
|        | Solid blue                        | CeC1712 authentication complete. CeC1712 successfully authenticated the BIOS Flash-0 and BMC Flash-0 images.   |

## 10/100/1000Base-T RJ-45 Management Port LEDs

The 10/100/1000Base-T RJ-45 Management port includes two LEDs that are both amber and green. The LEDs are located on each side of the RJ-45 port. The LED on the right side is labeled Speed and the LED on the left side is labeled Link/Activity. The following table describes the meaning of the colors and states for the LEDs.

**Table 12: 10/100/1000Base-T RJ-45 Management Port LEDs**

| LED   | Color/State | Description                        |
|-------|-------------|------------------------------------|
| Speed | Off         | The port is operating at 10 Mbps.  |
|       | Solid green | The port is operating at 1 Gbps.   |
|       | Solid amber | The port is operating at 100 Mbps. |

**Table 12: 10/100/1000Base-T RJ-45 Management Port LEDs (continued)**

| LED           | Color/State         | Description   |
|---------------|---------------------|---|
| Link/Activity | Solid green         | The port has link established. There is no data activity. |
|               | Blinking green      | The port has link established and there is data activity. |
|               | Slow blinking green | The port is disabled by the admin.                        |
|               | Solid amber         | Fault.  |

## SFP+/SFP28 Port LEDs for the 8520-48Y

Each port has one LED to indicate link or activity. The following table describes the states for the LED.

**Table 13: SFP+/SFP28 Port LEDs for the 8520-48Y**

| LED           | State               | Description   |
|---------------|---------------------|---|
| Link/Activity | Solid green         | The port has link established. There is no data activity. |
|               | Blinking green      | The port has link established and there is data activity. |
|               | Slow blinking green | The port is disabled by the admin.                        |
|               | Off                 | No link or fault.   |

## 1G/10G RJ45 Port LEDs for the 8520-48XT

Each port has one LED to indicate link or activity. The following table describes the states for the LED.

**Table 14: 1G/10G RJ45 Port LEDs for the 8520-48XT**

| LED           | State               | Description   |
|---------------|---------------------|---|
| Link/Activity | Solid green         | The port has link established. There is no data activity. |
|               | Blinking green      | The port has link established and there is data activity. |
|               | Slow blinking green | The port is disabled by the admin.                        |
|               | Off                 | No link or fault.   |

## QSFP28 Port LEDs

Each QSFP28 port has four green LEDs. The following table describes the states for the LEDs.

| Port Configuration | LEDs             | State   | Description                               |
|--------------------|------------------|---|---|
| 100 Gb or 40 Gb    | 1st LED          | Off   | No link.                                  |
|                    |                  | On  | Link is active, but there is no activity. |
|                    |                  | Blinking                                      | Link is active and there is activity.     |
|                    |                  | All LEDs blinking (on 1 second, off 1 second) | Switch is beaconing.                      |
| 50 Gb              | 1st and 3rd LEDs | Off   | No link.                                  |
|                    |                  | On  | Link is active, but there is no activity. |
|                    |                  | Blinking                                      | Link is active and there is activity.     |
|                    |                  | All LEDs blinking (on 1 second, off 1 second) | Switch is beaconing.                      |

| Port Configuration | LEDs     | State   | Description                               |
|--------------------|----------|---|---|
| 25 Gb or 10 Gb     | All LEDs | Off   | No link.                                  |
|                    |          | On  | Link is active, but there is no activity. |
|                    |          | Blinking                                      | Link is active and there is activity.     |
|                    |          | All LEDs blinking (on 1 second, off 1 second) | Switch is beaconing.                      |

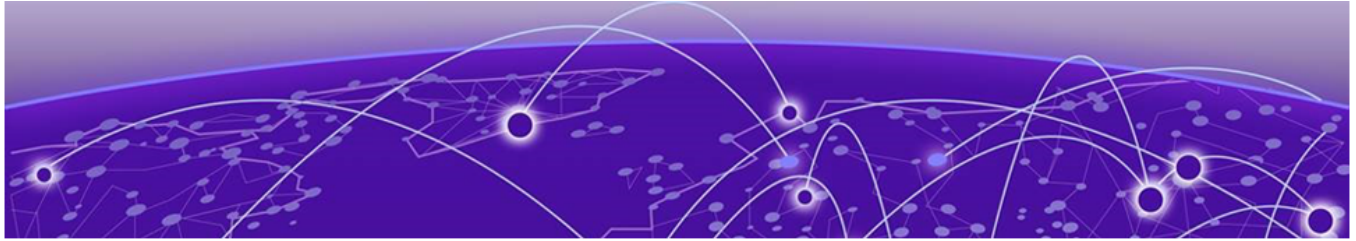

# Technical Specifications

---

[Extreme 8520 Technical Specifications](#) on page 69

[Acoustic Noise and Fan Speed](#) on page 72

[Mean Time Between Failures](#) on page 73

[Power Specifications](#) on page 73

[750 W Power Supplies Technical Specifications](#) on page 80

[Environmental](#) on page 82

[Standards](#) on page 83

[EMI/EMC Standards](#) on page 83

[Power Cord Requirements for AC-Powered Switches and AC Power Supplies](#) on page 85

[Console Connector Pinouts](#) on page 85

The following topics contain technical specifications for the hardware products described in this document.

## Extreme 8520 Technical Specifications

---

[Table 15](#) contains external interfaces and weights and dimensions information for Extreme 8520 switches.

**Table 15: External Interfaces**

|                | 8520-48Y   | 8520-48XT  |
|----------------|--|--|
| Ports          | <ul style="list-style-type: none"> <li>• 48 x 1/10/25GbE SFP28 ports</li> <li>• 8 x 40/100GbE QSFP28 ports</li> <li>• 1 x Serial console port RJ-45</li> <li>• 1 x 10/100/1000BASE-T out-of-band management port</li> <li>• USB Type A storage port</li> </ul> | <ul style="list-style-type: none"> <li>• 48 x 1/10GbE 10GBaseT ports</li> <li>• 6 x 40/100GbE QSFP28 ports</li> <li>• 1 x Serial console port RJ-45</li> <li>• 1 x 10/100/1000BASE-T out-of-band management port</li> <li>• USB Type A storage port</li> </ul> |
| Power Supplies | Modular 750W AC power supply (up to two PSUs) <ul style="list-style-type: none"> <li>• Modular 750W DC power supply (up to two PSUs)</li> <li>• Front to Back and Back to Front airflow options</li> </ul>   | Modular 750W AC power supply (up to two PSUs) <ul style="list-style-type: none"> <li>• Modular 750W DC power supply (up to two PSUs)</li> <li>• Front to Back and Back to Front airflow options</li> </ul>   |
| Fan Modules    | <ul style="list-style-type: none"> <li>• 6 fan modules</li> <li>• Front-Back and Back-Front airflow options</li> </ul>   | <ul style="list-style-type: none"> <li>• 6 fan modules</li> <li>• Front-Back and Back-Front airflow options</li> </ul>   |
| Dimensions     | 17.3 in W / 21.24 in D / 1.7 in H (44.0cm / 53.95cm / 4.3cm)   | 17.3in W / 20.9 in D / 1.7 in H (44.0cm / 53.2cm / 4.3cm)  |
| Weight         | 7.58 kg (16.71 lb) with no PSUs<br>10.0 kg (22.13 lb) with 2 AC PSUs<br>10.11 kg (22.29 lb) with 2 DC PSUs   | 7.41 kg (16.34 lb) with no PSUs<br>9.47 kg (20.88 lb) with 2 AC PSUs<br>9.54 kg (21.0 lb) with 2 DC PSUs   |
| Performance    | <ul style="list-style-type: none"> <li>• Line rate 4Tbps Switching Capacity (2Tbps ingress, 2Tbps egress)</li> <li>• Typical Latency: 800 ns</li> <li>• Forwarding rate: 1000 Mpps</li> </ul>  | <ul style="list-style-type: none"> <li>• Line rate 2.16 Tbps Switching Capacity (1.08Tbps ingress, 1.08Tbps egress)</li> <li>• Typical Latency: 2,400 ns</li> <li>• Forwarding rate: 1000 Mpps</li> </ul>  |
| CPU Memory     | <ul style="list-style-type: none"> <li>• 8-core Processor</li> <li>• 16GB DDR4 memory</li> <li>• 128GB SSD memory</li> </ul>   | <ul style="list-style-type: none"> <li>• 8-core Processor</li> <li>• 16GB DDR4 memory</li> <li>• 128GB SSD memory</li> </ul>   |

**Table 15: External Interfaces (continued)**

|                      | 8520-48Y   | 8520-48XT  |
|----------------------|--|--|
| Packet Buffers       | 32MB   | 32MB   |
| Operating Conditions | AC/DC, one fan failed, front-to-back:<br>0°C (32°F) to 50°C (122°F) at sea level;<br>0°C (32°F) to 40°C (104°F) up to 3000 m (10,000 ft) | AC/DC, one fan failed, back-to-front:<br>0°C (32°F) to 45°C (113°F) at sea level;<br>0°C (32°F) to 40°C (104°F) up to 3000 m (10,000 ft) |

**Table 16: Weights and Dimensions of Accessories**

| Accessory                                       | Weight            | Physical Dimensions  |
|---|-------------------|--|
| Fan unit, front-to-back or back-to-front        | 0.14 kg (0.31 lb) | Height: 4.0 cm (1.57 in)<br>Width: 4.0 cm (1.57 in)<br>Length: 13.4 cm (5.28 in)                       |
| Four-post rack mount kit (included with switch) | 2.63 kg (5.8 lb)  | Height: 2.1 cm (0.83 in)<br>Width: 4.4 cm (1.73 in)<br>Length: 63.0 cm - 90.0 cm (24.80 in - 35.43 in) |
| Two-post rack mount kit (separately orderable)  | 0.45 kg (0.99 lb) | Height: 5.0 cm (1.97 in)<br>Width: 7.0 cm (2.76 in)<br>Length: 72.0 cm (28.4 in)                       |

**Table 17: Console Cables**

|                          | Description                       |
|--------------------------|-----------------------------------|
| XN-RJ45-DB9-CONSOLE-CBL  | RJ45 to DB9 Console cable (6ft)   |
| XN-RJ45-USBA-CONSOLE-CBL | RJ45 to USBA Console cable (6ft)* |
| XN-RJ45-USBC-CONSOLE-CBL | RJ45 to USBC Console cable (6ft)* |

\* The cable might require an FTDI software driver on some operating systems.

## Acoustic Noise and Fan Speed

Table 18 includes acoustic specifications for Extreme 8520 switches under maximum operating conditions. Refer to the *Extreme 8520 Data Sheet* for up-to-date information

**Table 18: Acoustic Noise**

| Switch Model                      | Bystander Sound Pressure (at 25°C) | Declared Sound Power (at 25°C) |
|-----------------------------------|------------------------------------|--------------------------------|
| 8520-48Y (Front-to-Back Airflow)  | 52.2 dB(A)                         | 6.8 bels                       |
| 8520-48Y (Back-to-Front Airflow)  | 50.5 dB(A)                         | 6.7 bels                       |
| 8520-48XT (Front-to-Back Airflow) | 36.4 dB(A)                         | 5.5 bels                       |
| 8520-48XT (Back-to-Front Airflow) | 45.0 dB(A)                         | 6.3 bels                       |

Fan speeds are adjusted based on calculations of the temperatures on all sensors. Due to one fan being located behind the other, air pushed from one fan can cause the other fan in the module to run at a higher speed. One fan can run at medium speed while the other can spin at high speed if one is close to the temperature boundary.

**Table 19: Fan Tray and Speed Variation**

| Description  | Operation Status | Operation Speed | Airflow Direction |
|--------------|------------------|-----------------|-------------------|
| Tray 1 Fan 1 | up               | high speed      | Unknown*          |
| Tray 1 Fan 2 | up               | medium speed    | Unknown*          |
| Tray 2 Fan 1 | up               | high speed      | Unknown*          |
| Tray 2 Fan 2 | up               | medium speed    | Unknown*          |
| Tray 3 Fan 1 | up               | high speed      | Unknown*          |
| Tray 3 Fan 2 | up               | medium speed    | Unknown*          |
| Tray 4 Fan 1 | up               | high speed      | Unknown*          |
| Tray 4 Fan 2 | up               | medium speed    | Unknown*          |
| Tray 5 Fan 1 | up               | high speed      | Unknown*          |
| Tray 5 Fan 2 | up               | medium speed    | Unknown*          |
| Tray 6 Fan 1 | up               | high speed      | Unknown*          |
| Tray 6 Fan 2 | up               | medium speed    | Unknown*          |

\* - The color of the tab on the fan tray indicates the airflow direction:

- Red = Front-to-Back
- Blue = Back-to-Front

## Mean Time Between Failures

Table 20 includes mean time between failures (MTBF) information for Extreme 8520 switches.

**Table 20: Mean Time Between Failures**

| Switch Model      | Mean Time Between Failures               |
|-------------------|--|
| 8520-48Y-8C-AC-F  | 471,550 hrs @ 25°C<br>178,775 hrs @ 50°C |
| 8520-48Y-8C-AC-R  | 520,479 hrs @ 25°C<br>255,358 hrs @ 45°C |
| 8520-48Y-8C-DC-F  | 471,560 hrs @ 25°C<br>178,776 hrs @ 50°C |
| 8520-48Y-8C-DC-R  | 520,491 hrs @ 25°C<br>255,361 hrs @ 45°C |
| 8520-48XT-6C-AC-F | 439,148 hrs @ 25°C<br>187,306 hrs @ 50°C |
| 8520-48XT-6C-AC-R | 421,453 hrs @ 25°C<br>176,924 hrs @ 45°C |
| 8520-48XT-6C-DC-F | 421,453 hrs @ 25°C<br>187,308 hrs @ 50°C |
| 8520-48XT-6C-DC-R | 421,461 hrs @ 25°C<br>176,926 hrs @ 45°C |

## Power Specifications

This topic describes power supply specifications, power consumption, and heat dissipation. Refer to the *Extreme 8520 Data Sheet* for up-to-date information.

### Power Supply Specifications

Table 21 includes power supply specifications for Extreme 8520 switches.

**Table 21: Power Supply Specifications**

|                      | 750W AC PSU<br>XN-ACPWR-750W-F/ R                          | 750W DC PSU<br>XN-DCPWR-750W-F/ R                          |
|----------------------|--|--|
| Dimensions           | 3.15in W x 1.57in H x 8.11in D (8.0 cm x 4.0 cm x 20.6 cm) | 3.15in W x 1.57in H x 8.11in D (8.0 cm x 4.0 cm x 20.6 cm) |
| Weight               | 1.79lb(0.81kg)   | 1.85lb(0.85 kg)  |
| Voltage Input Range  | 100-140 VAC / 20 0 -240 VAC                                | -48 to -60 VDC   |
| Line Frequency Range | 50 – 60 HZ   | N/A  |
| PSU Input Socket     | IEC 320 C14  | Terminal Block   |

**Table 21: Power Supply Specifications (continued)**

|                      | 750W AC PSU<br>XN-ACPWR-750W-F/ R | 750W DC PSU<br>XN-DCPWR-750W-F/ R |
|----------------------|-----------------------------------|-----------------------------------|
| PSU Output Cord      | IEC 320 C13                       | N/A                               |
| Operating Conditions | 0° – 55° C operation              | 0° - 55° C operation              |

## Power Consumption

The following tables include power consumption information for the Extreme 8520 switches.

### 8520-48Y

The following tables provide AC and DC power consumption information for the 8520-48XT switches.

**Table 22: AC IN: 220V**

| Item | Test Mode    | Consumption (W) |      |              | Notes   |
|------|--------------|-----------------|------|--------------|---|
|      |              | Dual Power      |      | Single Power |   |
|      |              | PSU1            | PSU2 |              |   |
| 1    | Empty Model  | 109             | 104  | 207          | <ol style="list-style-type: none"> <li>No fiber transceivers inserted</li> <li>No port up link</li> <li>85% fan duty</li> </ol> |
| 2    | Standby Mode | 114             | 108  | 216          | <ol style="list-style-type: none"> <li>All ports up link</li> <li>85% fan duty</li> </ol>                                       |

**Table 22: AC IN: 220V (continued)**

| Item | Test Mode     | Consumption (W) |      |              | Notes  |
|------|---------------|-----------------|------|--------------|--|
|      |               | Dual Power      |      | Single Power |  |
|      |               | PSU1            | PSU2 |              |  |
| 3    | Typical Model | 121             | 116  | 232          | <ol style="list-style-type: none"> <li>Snake test with 70% traffic load (1518 byte packet length)</li> <li>85% fan duty</li> </ol> |
| 4    | Stress Model  | 154             | 148  | 299          | <ol style="list-style-type: none"> <li>Snake test with 100% traffic load (64 byte packet length)</li> <li>100% fan duty</li> </ol> |

**Table 23: AC IN: 110V**

| Item | Test Mode    | Consumption (W) |      |              | Notes   |
|------|--------------|-----------------|------|--------------|---|
|      |              | Dual Power      |      | Single Power |   |
|      |              | PSU1            | PSU2 |              |   |
| 1    | Empty Model  | 112             | 106  | 209          | <ol style="list-style-type: none"> <li>No fiber transceivers inserted</li> <li>No port up link</li> <li>85% fan duty</li> </ol> |
| 2    | Standby Mode | 118             | 111  | 223          | <ol style="list-style-type: none"> <li>All ports up link</li> <li>85% fan duty</li> </ol>                                       |

**Table 23: AC IN: 110V (continued)**

| Item | Test Mode     | Consumption (W) |       |              | Notes  |
|------|---------------|-----------------|-------|--------------|--|
|      |               | Dual Power      |       | Single Power |  |
|      |               | PSU1            | PSU12 |              |  |
| 3    | Typical Model | 126             | 119   | 239          | <ol style="list-style-type: none"> <li>Snake test with 70% traffic load (1518 byte packet length)</li> <li>85% fan duty</li> </ol> |
| 4    | Stress Model  | 158             | 152   | 302          | <ol style="list-style-type: none"> <li>Snake test with 100% traffic load (64 byte packet length)</li> <li>100% fan duty</li> </ol> |

**Table 24: DC IN: 48V**

| Item | Test Mode    | Consumption (W) |       |              | Notes   |
|------|--------------|-----------------|-------|--------------|---|
|      |              | Dual Power      |       | Single Power |   |
|      |              | PSU1            | PSU12 |              |   |
| 1    | Empty Model  | 130             | 100   | 226          | <ol style="list-style-type: none"> <li>No fiber transceivers inserted</li> <li>No port up link</li> <li>85% fan duty</li> </ol> |
| 2    | Standby Mode | 134             | 104   | 235          | <ol style="list-style-type: none"> <li>All ports up link</li> <li>85% fan duty</li> </ol>                                       |

**Table 24: DC IN: 48V (continued)**

| Item | Test Mode     | Consumption (W) |      |              | Notes  |
|------|---------------|-----------------|------|--------------|--|
|      |               | Dual Power      |      | Single Power |  |
|      |               | PSU1            | PSU2 |              |  |
| 3    | Typical Model | 141             | 111  | 251          | <ol style="list-style-type: none"> <li>Snake test with 70% traffic load (1518 byte packet length)</li> <li>85% fan duty</li> </ol> |
| 4    | Stress Model  | 178             | 145  | 325          | <ol style="list-style-type: none"> <li>Snake test with 100% traffic load (64 byte packet length)</li> <li>100% fan duty</li> </ol> |

**8520-48XT**

The following tables provide AC and DC power consumption information for the 8520-48XT switches.

**Table 25: AC IN: 220V**

| Item | Test Mode    | Consumption (W) |      |              | Notes   |
|------|--------------|-----------------|------|--------------|---|
|      |              | Dual Power      |      | Single Power |   |
|      |              | PSU1            | PSU2 |              |   |
| 1    | Empty Model  | 148.5           | 136  | 275.5        | <ol style="list-style-type: none"> <li>No fiber transceivers inserted</li> <li>No port up link</li> <li>85% fan duty</li> </ol> |
| 2    | Standby Mode | 155.8           | 143  | 289          | <ol style="list-style-type: none"> <li>All ports up link</li> <li>85% fan duty</li> </ol>                                       |

**Table 25: AC IN: 220V (continued)**

| Item | Test Mode     | Consumption (W) |       |              | Notes  |
|------|---------------|-----------------|-------|--------------|--|
|      |               | Dual Power      |       | Single Power |  |
|      |               | PSU1            | PSU12 |              |  |
| 3    | Typical Model | 162.2           | 148   | 302.5        | <ol style="list-style-type: none"> <li>Snake test with 70% traffic load (1518 byte packet length)</li> <li>85% fan duty</li> </ol> |
| 4    | Stress Model  | 204.8           | 189   | 389.5        | <ol style="list-style-type: none"> <li>Snake test with 100% traffic load (64 byte packet length)</li> <li>100% fan duty</li> </ol> |

**Table 26: AC IN: 110V**

| Item | Test Mode    | Consumption (W) |       |              | Notes   |
|------|--------------|-----------------|-------|--------------|---|
|      |              | Dual Power      |       | Single Power |   |
|      |              | PSU1            | PSU12 |              |   |
| 1    | Empty Model  | 149.8           | 138   | 250          | <ol style="list-style-type: none"> <li>No fiber transceivers inserted</li> <li>No port up link</li> <li>85% fan duty</li> </ol> |
| 2    | Standby Mode | 156.8           | 145   | 262          | <ol style="list-style-type: none"> <li>All ports up link</li> <li>85% fan duty</li> </ol>                                       |

**Table 26: AC IN: 110V (continued)**

| Item | Test Mode     | Consumption (W) |      |              | Notes  |
|------|---------------|-----------------|------|--------------|--|
|      |               | Dual Power      |      | Single Power |  |
|      |               | PSU1            | PSU2 |              |  |
| 3    | Typical Model | 164             | 151  | 275          | <ol style="list-style-type: none"> <li>Snake test with 70% traffic load (1518 byte packet length)</li> <li>85% fan duty</li> </ol> |
| 4    | Stress Model  | 205             | 191  | 354          | <ol style="list-style-type: none"> <li>Snake test with 100% traffic load (64 byte packet length)</li> <li>100% fan duty</li> </ol> |

**Table 27: DC IN: 48V**

| Item | Test Mode    | Consumption (W) |      |              | Notes   |
|------|--------------|-----------------|------|--------------|---|
|      |              | Dual Power      |      | Single Power |   |
|      |              | PSU1            | PSU2 |              |   |
| 1    | Empty Model  | 161             | 125  | 280          | <ol style="list-style-type: none"> <li>No fiber transceivers inserted</li> <li>No port up link</li> <li>85% fan duty</li> </ol> |
| 2    | Standby Mode | 168             | 132  | 295          | <ol style="list-style-type: none"> <li>All ports up link</li> <li>85% fan duty</li> </ol>                                       |

**Table 27: DC IN: 48V (continued)**

| Item | Test Mode     | Consumption (W) |      |              | Notes  |
|------|---------------|-----------------|------|--------------|--|
|      |               | Dual Power      |      | Single Power |  |
|      |               | PSU1            | PSU2 |              |  |
| 3    | Typical Model | 175             | 139  | 308          | <ol style="list-style-type: none"> <li>Snake test with 70% traffic load (1518 byte packet length)</li> <li>85% fan duty</li> </ol> |
| 4    | Stress Model  | 221             | 184  | 399          | <ol style="list-style-type: none"> <li>Snake test with 100% traffic load (64 byte packet length)</li> <li>100% fan duty</li> </ol> |

## Power and Heat Dissipation

Table 21 on page 73 includes power and heat dissipation information for Extreme 8520 switches.

**Table 28: Power and Heat Dissipation**

| Switch Model | Minimum Heat Dissipation (BTU/hr) (Idle, no ports linked) | Minimum Power Consumption (Watts) (Idle, no ports linked) | Maximum Heat Dissipation (BTU/hr) (Fans high, all ports 100% traffic) | Maximum Power Consumption (Watts) (Fans high, all ports 100% traffic) |
|--------------|---|---|---|---|
| 8520-48YAC   | 553BTU/ hr  | 167W  | 1600BTU/ hr   | 469W  |
| 8520-48YDC   | 553BTU/ hr  | 167W  | 1600BTU/ hr   | 469W  |
| 8520-48XTAC  | 642BTU/ hr  | 194W  | 1225BTU/ hr   | 359W  |
| 8520-48XTDC  | 642BTU/ hr  | 194W  | 1225BTU/ hr   | 359W  |

## 750 W Power Supplies Technical Specifications

Extreme 8520 switches support the following power supplies:

- Part number XN-ACPWR-750W-F (750 W AC power supply) provides front-to- back airflow for power supply cooling.
- Part number XN-ACPWR-750W-R (750 W AC power supply) provides back-to- front airflow for power supply cooling.

- Part number XN-DCPWR-750W-F (750 W DC power supply) provides front-to- back airflow for power supply cooling.
- Part number XN-DCPWR-750W-R (750 W DC power supply) provides back-to- front airflow for power supply cooling.

**Table 29: 750 W Power Supplies: Unpackaged Dimensions**

|  |  |
|--|--|
| 750 W power supply – AC front-to-back or back-to-front airflow | 10.83 in W/16.73 in D/17.52 in H (27.5 cm/42.5 cm/44.5 cm) |
| 750 W power supply – DC front-to-back or back-to-front airflow |  |

**Table 30: 750 W Power Supplies: Unpackaged Weight**

|  |                     |
|--|---------------------|
| 750 W power supply – AC front-to-back or back-to-front airflow | 10.22 kg (22.53 lb) |
| 750 W power supply – DC front-to-back or back-to-front airflow | 10.50 kg (23.15 lb) |

**Table 31: Power Specifications (AC Power Supplies)**

|                                     |   |
|-------------------------------------|---|
| Voltage input range                 | 85 to 264 V ~   |
| Nominal input ratings               | 100-140/200-240V ~, 10/5.36A max., 50/60Hz  |
| Nominal input current at full loads | 10 A at 90 V ~ (low-line)<br>3.7 A at 230 V ~ (high-line)   |
| Line frequency range                | 47 to 63 Hz   |
| Maximum inrush current              | 35 A  |
| Output                              | +12 V, 61.5 A<br>+12 Vsb, 3 A<br>Total output power not to exceed 750W                                    |
| Power supply input socket           | IEC 320 C14   |
| Power cord input plug               | IEC 320 C13   |
| Power cord wall plug                | Refer to <a href="#">Power Cord Requirements for AC-Powered Switches and AC Power Supplies</a> on page 85 |

**Table 31: Power Specifications (AC Power Supplies) (continued)**

|                         |  |
|-------------------------|--|
| Power supply cord gauge | 18 AWG (0.75 mm <sup>2</sup> ) up to 6 feet or 2 meters<br>or<br>16 AWG (1.0 mm <sup>2</sup> ) over 6 feet |
| Efficiency              | Low Line: 88% at 50% load and 86% at 100% load<br>High Line: 90% at 50% and 100% loads                     |

**Table 32: Power Specifications (DC Power Supplies)**

|                        |  |
|------------------------|--|
| Nominal input          | -48 to -60 VDC, 20.4 A                       |
| DC Voltage input range | -35 to -75 V                                 |
| Inrush Current         | 21 A peak                                    |
| Maximum wire size      | 14 AWG (1.5 mm <sup>2</sup> copper stranded) |
| DC Output              | +12.2VDC, 61.5A; +12Vaux, 2.5A               |
| Power (W)              | 750 W  |

**Table 33: Environmental Specifications (All Power Supply Units)**

|                       |  |
|-----------------------|--|
| Operating temperature | 0°C to 55°C (normal operation)               |
| Storage temperature   | -40°C to 70°C                                |
| Operating humidity    | 20% to 90% relative humidity, non-condensing |
| Operational shock     | 30 m/s <sup>2</sup> (3 G)                    |

## Environmental

### Environmental Specifications

EN/ETSI 300 019-2-1 v2.1.2 - Class 1.2 Storage

EN/ETSI 300 019-2-2 v2.1.2 - Class 2.3 Transportation

EN/ETSI 300 019-2-3 v2.1.2 - Class 3.1e Operational

EN/ETSI 300 753 (1997-10) - Acoustic Noise

ASTM D3580 Random Vibration Unpackaged 1.5 G

### Environmental Compliance

EU RoHS - 2011/65/EU

EU WEEE - 2012/19/EU

EU REACH – Regulation (EC) No 1907/2006 Reporting

China RoHS - SJ/T 11363-2006

Taiwan RoHS - CNS 15663(2013.7)

**Environmental Operating Conditions**

8520-48Y and 8520-48XT, AC/DC, one fan failed, front-to-back: 0°C (32°F) to 50°C (122°F) at sea level; 0°C (32°F) to 40°C (104°F) up to 3000 m (10,000 ft)

8520-48Y and 8520-48XT, AC/DC, one fan failed, back-to-front: 0°C (32°F) to 45°C (113°F) at sea level; 0°C (32°F) 40°C (104°F) to up to 3000 m (10,000 ft)

Humidity: 5% to 95% relative humidity, non-condensing

Altitude: 0 to 3,000 meters (9,850 feet)

Shock (half sine) 98m/s<sup>2</sup> (10G), 11 ms, 9 shocks

Random vibration: 3 to 500 Hz at 1.5 G rms

**Packaging and Storage Specifications**

Temp: -40°C to 70°C (-40°F to 158°F)

Humidity: 5% to 95% relative humidity, non-condensing

Packaged Shock (half sine): 180 m/s<sup>2</sup> (18 G), 6 ms, 600 shocks

Packaged Vibration: 5Hz to 62Hz at velocity 5 mm/s, 62Hz to 500Hz at 0.2 G

Packaged Random Vibration: 5Hz to 20Hz at 1.0 ASD w/-3 dB/oct. from 20Hz to 200Hz

Packaged Drop Height: 14 drops minimum on sides and corners at 42 inches (<15 kg box)

## Standards

---

**North American ITE**

UL 62368-1 2nd Ed., 2014-12-01, Listed Device (US)

UL 60950-1 2nd Ed., 2014-10-14, Listed Device (US)

CAN/CSA 22.2 #62368-1-14 2nd Ed., Canada

CAN/CSA 22.2 #60950-1-07 2nd Ed., Canada 2014-10

Complies with FCC 21 CFR Chapter 1, Sub-chapter J in accordance with FDA & CDRH requirements (US Laser Safety)

CDRH Letter of Approval (US FDA Approval)

**European ITE**

EN 62368-1:2014/A11:2017

2014/35/EU Low Voltage Directive

**International ITE**

CNS 14336-1

AS/NZX 60950-1 (Australia /New Zealand)

GB4943.1-2001

IEC/EN 60825-1:2007, IEC/EN 60825-2:2004+A1+A2 or later (Lasers Safety)

IEC 62368-1:2014 (2ndEd.)

IEC 60950-1:2005 (2nd Ed.) + Am 1:2009 + Am 2:2013 + National Difference

## EMI/EMC Standards

---

**North American EMC for ITE**

FCC 47 CFR part 15 subpart B Class A (USA)

IICES-003 (Canada)

### **European EMC Standards**

EN 300 386 V2.1.1(2016-07) Class A  
EN 55032:2015/AC:2016-07 Class A  
EN 55024:2010/A1:2015  
EN 55011:2009+A1:2010 (Group 1, Class A),  
EN 55035 EN 61000-6-2:2005+AC:2005  
EN 61000-6-4:2007+A1:2011  
EN 61000-3-2:2014 Class A  
EN 61000-3-3:2013  
EN 61000-4-2:2009  
EN 61000-4-3:2006+A1:2008+A2:2010  
EN 61000-4-4:2012  
EN 61000-4-5:2014  
EN 61000-4-6:2014/AC:2015  
EN 61000-4-8:2010  
EN 61000-4-11:2004/A1:2017

### **International EMC Certifications**

IEC 61000-6-2:2016 ED 3.0  
IEC 61000-6-4:2018 ED 3.0  
IEC 61000-4-2:2008 ED 2.0  
IEC 61000-4-3:2006+AMD1:2007+AMD2:2010 ED 3.2  
IEC 61000-4-4:2012 ED 3.0  
IEC 61000-4-5:2014+AMD1:2017+ ED 3.1  
IEC 61000-4-6:2013+ ED 4.0 IEC 61000-4-8:2009+ ED 2.0  
IEC 61000-4-11:2004+AMD1:2017+ ED 2.1  
CISPER 32:2015 ED 2.0 Class A, CISPER 35:2016 ED 1.0  
CISPER 24:2010+AMD1:2015 Class A  
CISPER 11:2009 ED 5.0 Group 1, Class A  
AS/NZS CISPER 32:2015 Class A  
GB/T9254-2008 Class A  
ANSI C63.4:2014

### **Country Specific**

RCM (Australia)  
VCCI Class A (Japan)  
MSIP KCC (Korea)  
BSMI (Taiwan)  
ANATEL (Brazil)  
CCC mark (China)  
NRCS (South Africa)  
CSA, FCC (North America)  
EAC mark (Custom Union)

**Telecom Standards**

- EN/ETSI 300 386:2008 (EMC Telecommunications)
- EN/ETSI 300 019 (Environmental for Telecommunications)
- MEF9 and MEF14 certified for EPL, EVPL, and ELAN

**IEEE 802.3 Media Access Standards**

- IEEE 802.3ab 1000BASE-T
- IEEE 802.3z 1000BASE-X
- IEEE 802.3ae 10GBASE-X
- IEEE 802.3ba 40GBASE-X

## Power Cord Requirements for AC-Powered Switches and AC Power Supplies

An AC power cord is not included with the AC power supply.

Power cords used with AC-powered switches or AC power supplies must meet the following requirements:

- The power cord must be agency-certified for the country of use.
- The power cord must have an appropriate AC connector for connection to the switch or power supply. See the power supply documentation for the appropriate power cord.
- The power cord must have an appropriately rated and approved wall plug applicable to the country of installation.

For details about obtaining AC power cords for use in your country, refer to <http://www.extremenetworks.com/product/powercords/>.

## Console Connector Pinouts

Table 34 describes the pinouts for a DB-9 console plug connector.

**Table 34: Pinouts for the DB-9 Console Connector**

| Function                  | Pin Number | Direction |
|---------------------------|------------|-----------|
| DCD (data carrier detect) | 1          | In        |
| RXD (receive data)        | 2          | In        |
| TXD (transmit data)       | 3          | Out       |
| DTR (data terminal ready) | 4          | Out       |
| GND (ground)              | 5          | -         |
| DSR (data set ready)      | 6          | In        |
| RTS (request to send)     | 7          | Out       |
| CTS (clear to send)       | 8          | In        |

Figure 25 shows the pinouts for a 9-pin to 25-pin (RS-232) null-modem cable.

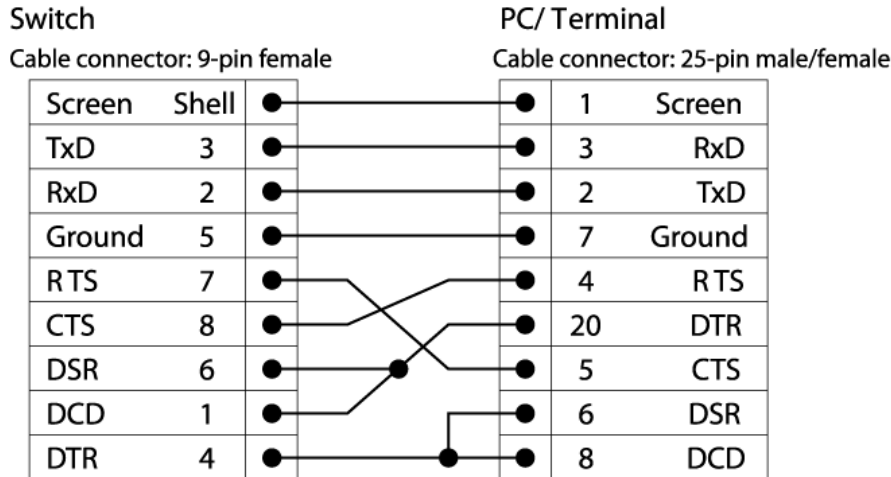

**Figure 25: Null-Modem Cable Pinouts**

Figure 26 shows the pinouts for a 9-pin to 9-pin (PC-AT) null-modem serial cable.

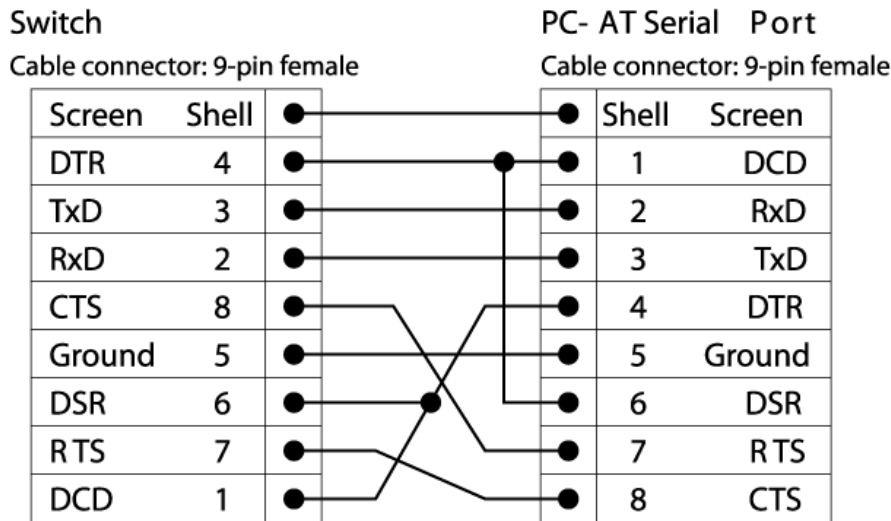

**Figure 26: PC-AT Serial Null-modem Cable Pinouts**

Table 35 shows the pinouts for the RJ45 console port on the ExtremeSwitching switches.

**Table 35: RJ45 Console Port on Switch**

| Function                  | Pin Number | Direction |
|---------------------------|------------|-----------|
| RTS (request to send)     | 1          | Out       |
| DTR (data carrier detect) | 2          | Out       |
| TXD (transmit data)       | 3          | Out       |
| GND (ground)              | 4          | —         |
| GND (ground)              | 5          | —         |
| RXD (receive data)        | 6          | In        |

**Table 35: RJ45 Console Port on Switch (continued)**

| Function             | Pin Number | Direction |
|----------------------|------------|-----------|
| DSR (data set ready) | 7          | In        |
| CTS (clear to send)  | 8          | In        |

Table 36 shows the pinouts for an RJ45-to-DB-9 adapter.

**Table 36: Pinouts for an RJ45 to DB-9 Adapter**

| Signal                    | RJ45 Pin | DB-9 Pin |
|---------------------------|----------|----------|
| CTS (clear to send)       | 1        | 8        |
| DTR (data carrier detect) | 2        | 6        |
| TXD (transmit data)       | 3        | 2        |
| GND (ground)              | 4        | 5        |
| GND (ground)              | 5        | 5        |
| RXD (receive data)        | 6        | 3        |
| DSR (data set ready)      | 7        | 4        |
| RTS (request to send)     | 8        | 7        |



# Safety Information

---

[Considerations Before Installing](#) on page 88

[General Safety Precautions](#) on page 89

[Maintenance Safety](#) on page 90

[Fiber Optic Ports and Optical Safety](#) on page 90

[Cable Routing for LAN Systems](#) on page 91

[Install Power Supply Units and Connect Power](#) on page 92

[Select Power Supply Cords](#) on page 93

[Battery Notice](#) on page 93

[Battery Warning - Taiwan](#) on page 94



## Note

Read the following safety information thoroughly before installing Extreme Networks products. Failure to follow this safety information can lead to personal injury or damage to the equipment.

Only trained and qualified service personnel (as defined in IEC 60950-1 and AS/NZS 3260) should install, replace, or perform service to Extreme Networks switches and their components. Qualified personnel have read all related installation manuals, have the technical training and experience necessary to be aware of the hazards to which they are exposed in performing a task, and are aware of measures to minimize the danger to themselves or other persons.

If you are located in the United States, install the system in accordance with the U.S. National Electrical Code (NEC).

## Considerations Before Installing

---

Consider the following items before you install equipment.

- For equipment designed to operate in a typical Telco environment that is environmentally controlled, choose a site that has the following characteristics:
  - Temperature-controlled and humidity-controlled, such that the maximum ambient room temperature shall not exceed 50°C (122°F).
  - Clean and free from airborne materials that can conduct electricity.
  - Well ventilated and away from sources of heat including direct sunlight.

- Away from sources of vibration or physical shock.
- Isolated from strong electromagnetic fields produced by electrical devices.
- For equipment designed to be installed in environments that are not environmentally controlled, such as outdoor enclosures, see the product data sheet or for environmental conditions, temperature, and humidity.
- Establish at least 3 inches clearance on all sides for effective ventilation. Do not obstruct the air intake vent on the front, side, or rear ventilation grills. Locate the system away from heat sources.
- Make sure that your equipment is placed in an area that accommodates the power consumption and component heat dissipation specifications.
- Make sure that your power supplies meet the site DC power or AC power requirements of all the network equipment.
- Racks for Extreme Networks equipment must be permanently attached to the floor. Failure to stabilize the rack can cause the rack to tip over when the equipment is removed for servicing.
- Do not operate the system unless all modules, faceplates, front covers, and rear covers are in place. Blank faceplates and cover panels are required for the following functions:
  - Preventing exposure to hazardous voltages and currents inside the equipment
  - Containing electromagnetic interference (EMI) that might disrupt other equipment
  - Directing the flow of cooling air through the equipment
- Ultimate disposal of this product should be handled according to all national laws and regulations.

## General Safety Precautions

---

Follow these guidelines:

- Do not try to lift objects that you think are too heavy for you.
- When you install equipment in a rack, load heavier devices in the lower half of the rack first to avoid making the rack top-heavy.
- Use only tools and equipment that are in perfect condition. Do not use equipment with visible damage.
- Route cables in a manner that prevents possible damage to the cables and avoids causing accidents, such as tripping.
- Do not place a monitor or other objects on top of the equipment. The chassis cover is not designed to support weight.
- To reduce the risk of fire, use only #26 AWG or larger telecommunications line cord. Use only copper conductors.
- Do not work on the system or connect or disconnect cables during periods of lightning activity.
- This equipment must be grounded. Never defeat the ground conductor or operate the equipment in the absence of a suitably installed ground conductor.

## Maintenance Safety

---

When you perform maintenance procedures on Extreme Networks equipment, follow these recommendations:

- Use only authorized accessories or components approved for use with this system. Failure to follow these instructions may damage the equipment or violate required safety and EMC regulations.
- This system contains no customer serviceable components. Do not attempt to repair a chassis, power supply, module, or other component. In the event of failure, return the defective unit to Extreme Networks for repair or replacement, unless otherwise instructed by an Extreme Networks representative.
- To remove power from the system, you must unplug all power cords from wall outlets. The power cord is the disconnect device to the main power source.
- Disconnect all power cords before working near power supplies, unless otherwise instructed by a product-specific maintenance procedure.
- Replace a power cord immediately if it shows any signs of damage.
- When you work with optical devices, power supplies, or other modular accessories, put on an ESD-preventive wrist strap to reduce the risk of electronic damage to the equipment. Connect the other end of the strap to an appropriate grounding point on the equipment rack or to an ESD jack on the chassis if one is provided. Leave the ESD-preventive wrist strap permanently attached to the equipment rack or chassis so that it is always available when you need to handle components that are sensitive to ESD.
- Install all cables in a manner that avoids strain. Use tie wraps or other strain relief devices.

## Fiber Optic Ports and Optical Safety

---

The following safety warnings apply to all optical devices used in Extreme Networks equipment that are removable or directly installed in an I/O module or chassis system.

Such devices include but are not limited to gigabit interface converters (GBICs), small form factor pluggable (SFP) modules (or mini-GBICs), QSFP+ modules, XENPAK transceivers, and XFP laser optic modules.



### Warning

Laser optic modules become very hot after prolonged use. Take care when removing a laser optic module from the module or option card. If the laser optic module is too hot to touch, disengage the laser optic module and allow it to cool before removing it completely.

When working with laser optic modules, always take the precautions listed below to avoid exposure to hazardous radiation.

- Never look at the transmit LED/laser through a magnifying device while the transmit LED is powered on.
- Never look directly at a fiber port on the switch or at the ends of a fiber cable when they are powered on.

- Invisible laser radiation can occur when the connectors are open. Avoid direct eye exposure to the beam when optical connections are unplugged.
- Never alter, modify, or change an optical device in any way other than suggested in this document.

## GBIC, SFP (Mini-GBIC), QSFP+, XENPAK, and XFP Regulatory Compliance

Extreme Networks pluggable optical modules and direct-attach cables meet the following regulatory requirements:

- Class 1 or Class 1M Laser Product
- EN60825-1:2007 2nd Ed. or later, European standard
- FCC 21 CFR Chapter 1, Subchapter J in accordance with FDA & CDRH requirements
- Application of CE Mark in accordance with 2014/30/EU EMC Directive and the 2014/35/EU Low Voltage Directives
- UL and/or CSA registered component for North America
- 47 CFR Part 15, Class A when installed into Extreme products

## Cable Routing for LAN Systems

Extreme Networks equipment meets the requirements for LAN system equipment.

LAN systems are designed for intra-building installations; that is, cable runs between devices must be in the same building as the connected units, except under the conditions listed in the next paragraph.

As allowed in the USA by the National Electrical Code (NEC), this equipment can be connected between buildings if any one of the following conditions is true:

- Cable runs between buildings are less than 140 feet long.
- Cable runs between buildings are directly buried.
- Cable runs between buildings are in an underground conduit, where a continuous metallic cable shield or a continuous metallic conduit containing the cable is bonded to each building grounding electrode system.



### Caution

Failure to follow these requirements for cable routing conditions may expose the user to electrical shock and expose the unit to damage that can cause errors.

**Warning**

The Ethernet ports of the equipment and its sub-assemblies are suitable only for intra-building connections (within the same building) or for connections to unexposed wiring or cabling. (See the conditions listed above.) The Ethernet ports of this equipment or its sub-assemblies must not be metalically connected to interfaces that connect to the outside plant (OSP) or its wiring. Ethernet interfaces are designed for use only as intra-building interfaces (described as Type 2 or Type 4 ports in GR-1089-CORE, Issue 6) and require isolation from the exposed OSP wiring. The addition of Primary Protectors is not sufficient protection to connect these interfaces metalically to OSP wiring.

## Install Power Supply Units and Connect Power

---

For the ratings and power input requirements of each power supply unit, see [Technical Specifications](#) on page 69 or the data sheet for the power supply at [www.extremenetworks.com](http://www.extremenetworks.com).

**Warning**

Be sure to satisfy the requirements listed in this section when you install Extreme Networks power supplies or connect power.

When you install any power supply:

- Do not use excessive force when you insert a power supply into the bay.
- Do not attempt to open the power supply enclosure for any reason; the power supply does not contain user-serviceable parts. In the event of failure, return the defective power supply to Extreme Networks for repair or replacement.
- Do not put your hand into an open power supply bay when a power supply is not present.
- Before you work on equipment that is connected to power lines, remove all jewelry, including watches. Metal objects heat up when they are connected to power and ground and can cause serious burns or weld the metal object to the terminals.
- An electrical arc can occur when you connect or disconnect the power with power applied. This could cause an explosion in hazardous area installations. Be sure that power is removed from the device.
- When you install or replace equipment, always make the ground connection first and disconnect the ground connection last.

When you install DC power supplies or connect DC power:

- Extreme Networks DC power supplies do not have switches for turning the unit on and off. Make sure that the DC circuit is de-energized before connecting or disconnecting the DC power cord at the DC input power socket.

- Connect the system or power supply only to a DC power source that complies with the safety extra-low voltage (SELV) requirements in IEC 60950-based safety standards.

**Note**

Because building codes vary worldwide, consult an electrical contractor to ensure proper equipment grounding and power distribution for your specific installation and country.

**Warning**

Extreme Networks power supplies do not have switches for turning the unit on and off. Disconnect all power cords to remove power from the device. Make sure that these connections are easily accessible.

Extreme Networks alimentations n'ont pas de contact pour mettre l'appareil sous et hors tension. Débranchez tous les cordons d'alimentation pour couper l'alimentation de l'appareil. Assurez-vous que ces connexions sont facilement accessibles.

## Select Power Supply Cords

---

You can purchase a power cord for your product and for your specific country from your local Extreme Networks Channel Account Manager or Sales Manager, or you can purchase a cord from your local supplier. Requirements for the power cord are listed in the Technical Specifications for your product.

To locate a Sales Manager or Partner in your region, visit [www.extremenetworks.com/partners/where-to-buy](http://www.extremenetworks.com/partners/where-to-buy).

**Note**

This equipment is not intended to be directly powered by power distribution systems where phase-phase voltages exceed 240 VAC (2P+PE), such as those used in Norway, France, and other countries. For these applications, use a transformer to step down the voltage to < 240 VAC from phase-phase, or make a connection to a (P+N+PE) power distribution where voltages do not exceed 240 VAC.

All installations should confirm that the product is reliably grounded according to the country's local electrical codes.

## Battery Notice

---



**Warning:** This product contains a battery used to maintain product information. If the battery should need replacement it must be replaced by Service Personnel. Please contact Technical Support for assistance.

Risk of explosion if battery is replaced by an incorrect type. Dispose of expended battery in accordance with local disposal regulations.



**Attention:** Ce produit renferme une pile servant à conserver les renseignements sur le produit. Le cas échéant, faites remplacer la pile par le personnel du service de réparation. Veuillez communiquer avec l'assistance technique pour du soutien.

Il y a risque d'explosion si la pile est remplacée par un type de pile incorrect. Éliminez les piles usées en conformité aux règlements locaux d'élimination des piles.

## Battery Warning - Taiwan

---

### 警告

如果更換不正確之電池型式會有爆炸的風險，  
請依製造商說明書處理用過之電池。



# Regulatory Information

---

- [CE statement](#) on page 95
- [EMC Warnings](#) on page 96
- [China and Taiwan: Restriction of Hazardous Substances \(ROHS\)](#) on page 96
- [Canadian requirements](#) on page 96
- [China CCC statement](#) on page 97
- [Australia \(RCM\)](#) on page 97
- [Federal Communications Commission \(FCC\) Notice](#) on page 97
- [Germany statement](#) on page 98
- [KCC statement \(Republic of Korea\)](#) on page 98
- [Japan \(VCCI Class A\)](#) on page 98
- [Japan power cord](#) on page 99

## CE statement

---



### Important

This is a Class A product. In a domestic environment, this product might cause radio interference, and the user might be required to take corrective measures.

The standards compliance label on this device contains the CE mark which indicates that this system conforms to the provisions of the following European Council directives, laws, and standards:

- Electromagnetic Compatibility (EMC) Directive 2014/30/EU
- Low Voltage Directive (LVD) 2014/35/EU
- EN 55032/EN 55024 (European Immunity Requirements)
  - EN61000-3-2/IEC61000-3-2 (European and Japanese Harmonics Spec)
  - EN61000-3-3

## EMC Warnings

---

### Taiwan BSMI Warning

**警告使用者:**

此為甲類資訊技術設備，於居住環境中使用時，可能會造成射頻擾動，在此種情況下，使用者會被要求採取某些適當的對策。

### China CQC Warning

**警告使用者:**

此为A级产品，在生活环境中，该产品可能会造成无线电干扰。

在这种情况下，可能需要用户对干扰采取切实可行的措施。

## China and Taiwan: Restriction of Hazardous Substances (ROHS)

---

For more information, see <https://www.extremenetworks.com/company/legal/restriction-of-hazardous-substances/>.

## Canadian requirements

---

This Class A digital apparatus meets all requirements of the Canadian Interference-Causing Equipment Regulations, ICES-003 Class A.

Cet appareil numérique de la classe A est conforme à la norme NMB-003 du Canada.



device must accept any interference received, including interference that may cause undesired operation.



#### Note

This equipment has been tested and found to comply with the limits for a class A digital device, pursuant to Part 15 of the FCC rules. These limits are designed to provide reasonable protection against harmful interference when the equipment is operated in a commercial environment. This equipment uses, generates, and can radiate radio frequency energy and if not installed in accordance with the operator's manual, may cause harmful interference to radio communications. Operation of this equipment in a residential area is likely to cause interference in which case the user will be required to correct the interference at his own expense.

**WARNING:** Changes or modifications made to this device which are not expressly approved by the party responsible for compliance could void the user's authority to operate the equipment.

## Germany statement

---

Machine noise information regulation - 3. GPSGV, the highest sound pressure level value is 70.0 dB(A) in accordance with EN ISO 7779.

Maschinenlärminformations-Verordnung - 3. GPSGV, der höchste Schalldruckpegel beträgt 70.0 dB(A) gemäss EN ISO 7779.

## KCC statement (Republic of Korea)

---

이 기기는 업무용 환경에서 사용할 목적으로 적합성평가를 받은 기기로서 가정용 환경에서 사용하는 경우 전파간섭의 우려가 있습니다.

Class A device (Broadcasting Communication Device for Office Use): This device obtained EMC registration for office use (Class A), and may be used in places other than home. Sellers and/or users need to take note of this.

## Japan (VCCI Class A)

---



#### Warning

This is a Class A product based on the standard of the VCCI Council. If this equipment is used in a domestic environment, radio interference may occur, in which case the user may be required to take corrective actions.

この装置は、クラスA機器です。この装置を住宅環境で使用すると電波妨害を引き起こすことがあります。この場合には使用者が適切な対策を講ずるよう要求されることがあります。 VCCI-A

## Japan power cord

---



**注意** – 添付の電源コードを他の装置や用途に使用しない

添付の電源コードは本装置に接続し、使用することを目的として設計され、その安全性が確認されているものです。決して他の装置や用途に使用しないでください。火災や感電の原因となる恐れがあります。

### *English translation of above statement*

ATTENTION: Never use the power cord packed with your equipment for other products.