



Extreme OS ONE Switching and Routing v22.2.2.0 Layer 3 Configuration Guide

Routing, BGP, EVPN, and VxLAN Implementation

9039561-00 Rev AA
April 2026



Copyright © 2026 Extreme Networks, Inc. All rights reserved.

Legal Notice

Extreme Networks, Inc. reserves the right to make changes in specifications and other information contained in this document and its website without prior notice. The reader should in all cases consult representatives of Extreme Networks to determine whether any such changes have been made.

The hardware, firmware, software or any specifications described or referred to in this document are subject to change without notice.

Trademarks

Extreme Networks® and the Extreme Networks logo are trademarks or registered trademarks of Extreme Networks, Inc. in the United States and/or other countries.

All other names (including any product names) mentioned in this document are the property of their respective owners and may be trademarks or registered trademarks of their respective companies/owners.

For additional information on Extreme Networks trademarks, see: <https://www.extremenetworks.com/about-extreme-networks/company/legal/trademarks>

Open Source Declarations

Some software files have been licensed under certain open source or third-party licenses.

End-user license agreements and open source declarations can be found at: <https://www.extremenetworks.com/support/policies/open-source-declaration/>



Table of Contents

Abstract.....	ix
Preface.....	x
Text Conventions.....	x
Documentation and Training.....	xi
Open Source Declarations.....	xii
Training.....	xii
Help and Support.....	xii
Subscribe to Product Announcements.....	xiii
Send Feedback.....	xiii
About This Document.....	14
What's New in This Document.....	15
Supported Platforms.....	17
IPv4 Addressing.....	18
IPv4 Addressing Overview.....	18
IP interfaces.....	19
ARP Cache.....	19
Virtual Routing and Forwarding (VRF).....	20
Sample VRF Configuration.....	20
IP Addressing.....	21
Static Routing.....	22
ECMP Maximum Paths.....	22
Resilient Hashing.....	22
Load Balancing (Hashing).....	22
Configure Ethernet Load Balancing.....	22
Configure Layer 3 Load Balancing.....	23
Configure Layer 4 Load Balancing.....	24
IP Parameters and Protocols.....	24
Address Resolution Protocol.....	24
ARP Overview.....	25
Configure ARP Reachable Time for Remote IPv4 Nodes.....	25
Configure a Static ARP Entry for an Interface.....	26
Assign an IPv4 Address to a Loopback Interface.....	28
Assign IPv4 addresses to Non-Loopback Interfaces.....	28
IPv4 Management.....	30
IPv4 Ping.....	31
IPv4 Traceroute.....	31
Delete an IP Address from an Interface.....	32
The Domain Name System.....	32
Configure a DNS Domain and Gateway Addresses.....	33
Configure the Source IP Address for Various Packet Types.....	34
IPv4 ICMP Rate Limiting on the Management Interface.....	35

IPv4 Addressing Show and Clear Commands.....	35
IPv6 Addressing.....	37
IPv6 Addressing Overview.....	37
IP interfaces.....	38
Assign an IPv6 Address to a Loopback Interface.....	38
Assign IPv6 Addresses to Non-Loopback Interfaces.....	39
IPv6 Management.....	41
IPv6 Ping.....	41
IPv6 Traceroute.....	42
IPv6 Neighbor Discovery	43
Router Advertisement and Solicitation Messages.....	43
Configure IPv6 Router Advertisement.....	44
Duplicate Address Detection.....	47
Configure a Static Neighbor Entry for an Interface.....	47
Configure Reachable Time for Remote IPv6 Nodes.....	48
IPv6 ICMP Rate Limiting on the Management Interface.....	50
Display Global IPv6 Information	50
Clear Global IPv6 Information.....	52
IPv4 Static Routing.....	53
IPv4 Static Routing.....	53
IPv4 Static Route Availability.....	54
Default VRF and User-Defined VRFs.....	55
BFD for Layer 3 Protocols.....	56
Configure a Basic IPv4 Static Route.....	57
Configure an IPv4 Static Route with an Interface Next Hop.....	57
Configure a BFD session for an IPv4 static route.....	58
Disable Recursive Lookup for an IPv4 Static Route.....	59
Add a Cost Metric or Administrative Distance to an IPv4 Static Route.....	60
Configure an IPv4 Static Route to Use with a Route Map.....	60
Configure an IPv4 Null Static Route.....	61
Configure a Default IPv4 Static Route.....	62
Configure IPv4 Static Routes for Load Sharing and Redundancy.....	62
Remove an IPv4 Static Route.....	64
Display IPv4 Static Route Information.....	65
IPv6 Static Routing.....	67
IPv6 Static Routing.....	67
IPv6 Static Route Availability.....	68
Default VRF and User-Defined VRFs.....	68
Configure a Basic IPv6 Static Route.....	70
Configure an IPv6 Static Route with an Interface Next Hop.....	70
Configure a BFD session for an IPv6 static route.....	71
Disable Recursive Lookup for an IPv6 Static Route.....	72
Add a Cost Metric or Administrative Distance to an IPv6 Static Route.....	72
Configure an IPv6 Static Route to Use with a Route Map.....	73
Configure an IPv6 Null Static Route.....	73
Configure a Default IPv6 Static Route.....	75
Configure IPv6 Static Routes for Load Sharing and Redundancy.....	75
Remove an IPv6 Static Route.....	77

Display IPv6 Static Route Information.....	78
Layer 3 Policy Based Routing.....	81
Routing Policy.....	81
How it works.....	81
Configuring Routing Policies.....	81
Creating Routing Policies.....	82
Attaching Routing Policies.....	83
Routing Policy Configuration Commands.....	86
BGP4.....	90
BGP4 Capabilities and Limitations.....	90
Limitation.....	91
Supported BGP Features.....	91
BGP Communities, Extended Communities, and Route Filtering.....	91
BGP4 Peering.....	92
BGP Static Peers.....	93
BGP Peering with Listen Range.....	93
BGP Peering with Next Hop Resolution.....	94
BGP4 Message Types.....	95
OPEN message.....	95
UPDATE message.....	96
NOTIFICATION message.....	97
KEEPALIVE message.....	97
REFRESH message.....	98
BGP Best Path Selection.....	98
How BGP Selects the Best Route.....	98
Key Points.....	98
BGP Route Origination through Redistribution.....	99
How BGP Redistribution Works.....	99
Key Points.....	99
Configuring BGP Redistribution.....	99
BGP Route Origination through the Network.....	101
How it Works.....	101
Key Differences and Benefits.....	102
Key Points.....	102
Configuring BGP Route Origination through Network	102
BGP Route Origination through Default Route.....	103
CLIs for BGP Default Route Origination at the Global Level.....	103
CLIs for BGP Route Default Route Origination at the Peer Group Level.....	104
BGP Additional Paths.....	106
Key Components.....	106
Implementation Considerations and Limitations.....	106
Configuring BGP Additional Paths.....	107
Support Additional Paths in BGP.....	108
Capability Negotiation for Add Path.....	108
NLRI Processing.....	109
Process Additional Paths.....	109
Event Log Messages for BGP Add-Path.....	111
BGP Allow-Own-AS.....	111

Why Allow-Own-AS?.....	111
Key Points.....	111
Configuring BGP Allow-Own-As.....	112
BGP Local-AS-Forced.....	112
Configuring BGP Local-AS-Forced.....	112
Configure BGP MD5 Authentication.....	113
BGP Multiprotocol	114
BGP Route Refresh.....	114
Key Points.....	114
Configure EBGP Multihop: Extending BGP Reachability.....	115
Key Benefits and Considerations.....	115
Comparison to Standard BGP.....	115
BGP Fast External Failover.....	116
Configuring BGP Fast External Failover.....	116
BGP IPv6.....	117
BGP IPv6 Prefix Advertisement over IPv4 BGP Peers.....	117
Overview of BGP IPv6 Prefix Advertisement over IPv4 BGP Peers.....	117
Key Components.....	118
Benefits.....	118
Limitations.....	118
Session Behavior.....	119
Resource Impact.....	119
Next-Hop Handling.....	119
Next-Hop Reachability Considerations.....	119
Prerequisites.....	120
Enable the BGP IPv6 Prefix Advertisement over IPv4 BGP Peers Feature.....	120
Verification and Monitoring.....	121
BGP Monitoring with Bidirectional Forwarding Detection (BFD).....	124
Configuration Considerations.....	124
Configuring BGP Monitoring with BFD	124
BGP Protocol Event Monitoring and Notification.....	125
Supported Functionalities.....	125
BGP Enterprise and Standard MIB Notifications.....	125
RASlogs.....	127
Configure BGP Address Families.....	128
BGP4 Peer Groups.....	128
How Peer Groups Work.....	129
Key Benefits.....	129
Configure a BGP4 Peer Group.....	129
BGP Four-Byte AS Number.....	130
AS Number Format.....	130
BGP Multi-VRF.....	131
BGP Router-ID.....	131
Configure BGP4 Route Reflection.....	132
Configure a Cluster ID for a BGP4 Route Reflector.....	132
Configure a BGP4 Route Reflector Client.....	133
Configure BGP Prefix Independent Convergence.....	133
Functional overview.....	133
Benefits.....	134

BGP PIC Functional Scenarios.....	134
BGP PIC Configuration Considerations.....	136
BGP and BFD Session Down Event.....	136
Configure BGP Prefix-Independent Convergence.....	136
BGP4 Graceful Restart.....	137
Configure BGP Graceful Restart.....	138
BGP Ethernet VPN for IP Fabrics.....	141
BGP EVPN for IP Fabrics Features and Benefits.....	141
Key Features.....	141
Key Benefits.....	142
Build Modern Data Centers with VxLAN and BGP.....	142
Data Center IP Fabric Architecture.....	143
Key Characteristics.....	143
Border Node Functionality	143
Benefits.....	143
Underlay Network.....	143
Overlay Networks.....	144
Layer 2 or Layer 3 Multitenancy with VxLAN.....	145
Basic Terminologies.....	146
IP Topology.....	146
MAC Synchronization (Type 2).....	150
Local MAC Learning.....	150
MAC Route Origination.....	151
Received MAC Routes.....	151
End-to-End Data Path.....	151
MLAG Considerations.....	151
MAC Route Selection.....	151
MAC Move.....	151
Layer 2 Extension.....	152
Layer 3 Extension.....	152
ARP or ND Synchronization and Routing.....	152
Local ARP or ND Learning.....	152
Propagation of ARP or ND Learn Events.....	152
Origination of ARP or ND Routes.....	152
Asymmetric and Symmetric Routing.....	152
MLAG and Route Selection.....	153
Centralized vs. Distributed Routing.....	153
EVPN Model Overview.....	153
Key Differences.....	153
Implications.....	153
Module Interactions for BGP EVPN.....	153
BGP EVPN Configuration Examples.....	155
BGP EVPN Neighbor Configuration Examples.....	155
BGP EVPN Instance Configuration Examples.....	157
Static VxLAN.....	159
Static VxLAN Overview.....	159
Traffic Behavior.....	159
Split Horizon.....	160

Head-End Replication.....	160
Sample Topology.....	160
Example Output.....	160
Static VxLAN Limitations.....	160
Event Log Messages.....	161
Configure Static VxLAN.....	161
Configuring Network Virtualization Overlay (NVO).....	161
Configuring Network Virtualization Endpoint (NVE).....	161
Configuring VNI Domain.....	162
Manual VNI Configuration for Bridge Domain.....	162
Default VNI Offset Configuration.....	162
VxLAN Tunnel Configuration.....	162
Resilient Hashing.....	163
Static Hashing versus Resilient Hashing in ECMP Routing.....	163
Static Hashing in ECMP Routing.....	163
Resilient Hashing in ECMP Routing.....	164
Key Benefits.....	164
Limitations.....	164
Best Practices.....	164
Impact of Configuration Changes.....	165
Scalability.....	165
Extreme 8520, Extreme 8720, and Extreme 8730 Platforms.....	165
Extreme 8820 Platform.....	165
Configure Resilient Hashing.....	166
Configure ECMP Maximum Paths.....	166
Enable Resilient Hashing on a VRF.....	167
Display ECMP Maximum Paths Route Information for VRFs.....	168
Logging.....	169

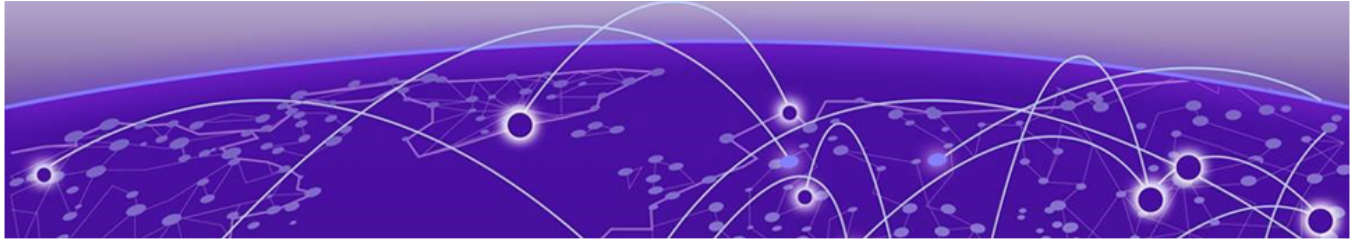

Abstract

The *Extreme OS ONE SR Layer 3 Configuration Guide* version 22.2.2.0 provides advanced technical instructions for deploying and managing Layer 3 routing. The guide details comprehensive procedures for IPv4 and IPv6 addressing, static and policy-based routing, ECMP load balancing with resilient hashing, and VRF-based traffic segmentation. The content is tailored for experienced network engineers and assumes an advanced technical background.

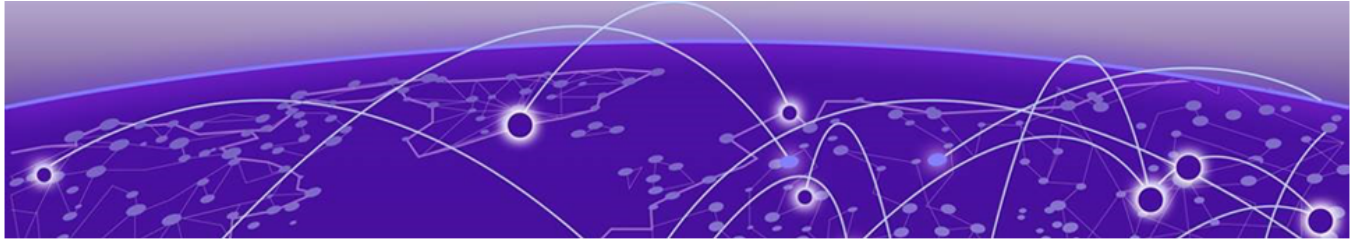

Preface

Read the following topics to learn about:

- The meanings of text formats used in this document.
- Where you can find additional information and help.
- How to reach us with questions and comments.

Text Conventions

Unless otherwise noted, information in this document applies to all supported environments for the products in question. Exceptions, like command keywords associated with a specific software version, are identified in the text.

When a feature, function, or operation pertains to a specific hardware product, the product name is used. When features, functions, and operations are the same across an entire product family, such as Extreme Networks switches, the product is referred to as *the switch*.

Table 1: Notes and warnings





Icon	Notice type	Alerts you to..
	Tip	Helpful tips and notices for using the product
	Note	Useful information or instructions
	Important	Important features or instructions
	Caution	Risk of personal injury, system damage, or loss of data
	Warning	Risk of severe personal injury

Table 2: Text

Convention	Description
screen displays	This typeface indicates command syntax, or represents information as it is displayed on the screen.
The words <i>enter</i> and <i>type</i>	When you see the word <i>enter</i> in this guide, you must type something, and then press the Return or Enter key. Do not press the Return or Enter key when an instruction simply says <i>type</i> .
Key names	Key names are written in boldface, for example Ctrl or Esc . If you must press two or more keys simultaneously, the key names are linked with a plus sign (+). Example: Press Ctrl+Alt+Del
<i>Words in italicized type</i>	Italics emphasize a point or denote new terms at the place where they are defined in the text. Italics are also used when referring to publication titles.
NEW!	New information. In a PDF, this is searchable text.

Table 3: Command syntax

Convention	Description
bold text	Bold text indicates command names, keywords, and command options.
<i>italic text</i>	Italic text indicates variable content.
[]	Syntax components displayed within square brackets are optional. Default responses to system prompts are enclosed in square brackets.
{ x y z }	A choice of required parameters is enclosed in curly brackets separated by vertical bars. You must select one of the options.
x y	A vertical bar separates mutually exclusive elements.
< >	Nonprinting characters, such as passwords, are enclosed in angle brackets.
...	Repeat the previous element, for example, <i>member [member...]</i> .
\	In command examples, the backslash indicates a “soft” line break. When a backslash separates two lines of a command input, enter the entire command at the prompt without the backslash.

Documentation and Training

Find Extreme Networks product information at the following locations:

[Current Product Documentation](#)

[Release Notes](#)

[Hardware and Software Compatibility](#) for Extreme Networks products

[Extreme Optics Compatibility](#)

[Other Resources](#) such as articles, white papers, and case studies

Open Source Declarations

Some software files have been licensed under certain open source licenses. Information is available on the [Open Source Declaration](#) page.

Training

Extreme Networks offers product training courses, both online and in person, as well as specialized certifications. For details, visit the [Extreme Networks Training](#) page.

Help and Support

If you require assistance, contact Extreme Networks using one of the following methods:

Extreme Portal

Search the GTAC (Global Technical Assistance Center) knowledge base; manage support cases and service contracts; download software; and obtain product licensing, training, and certifications.

The Hub

A forum for Extreme Networks customers to connect with one another, answer questions, and share ideas and feedback. This community is monitored by Extreme Networks employees, but is not intended to replace specific guidance from GTAC.

Call GTAC

For immediate support: (800) 998 2408 (toll-free in U.S. and Canada) or 1 (408) 579 2800. For the support phone number in your country, visit www.extremenetworks.com/support/contact.

Before contacting Extreme Networks for technical support, have the following information ready:

- Your Extreme Networks service contract number, or serial numbers for all involved Extreme Networks products
- A description of the failure
- A description of any actions already taken to resolve the problem
- A description of your network environment (such as layout, cable type, other relevant environmental information)
- Network load at the time of trouble (if known)
- The device history (for example, if you have returned the device before, or if this is a recurring problem)
- Any related RMA (Return Material Authorization) numbers

Subscribe to Product Announcements

You can subscribe to email notifications for product and software release announcements, Field Notices, and Vulnerability Notices.

1. Go to [The Hub](#).
2. In the list of categories, expand the **Product Announcements** list.
3. Select a product for which you would like to receive notifications.
4. Select **Subscribe**.
5. To select additional products, return to the **Product Announcements** list and repeat steps 3 and 4.

You can modify your product selections or unsubscribe at any time.

Send Feedback

The User Enablement team at Extreme Networks has made every effort to ensure that this document is accurate, complete, and easy to use. We strive to improve our documentation to help you in your work, so we want to hear from you. We welcome all feedback, but we especially want to know about:

- Content errors, or confusing or conflicting information.
- Improvements that would help you find relevant information.
- Broken links or usability issues.

To send feedback, email us at Product-Documentation@extremenetworks.com.

Provide as much detail as possible including the publication title, topic heading, and page number (if applicable), along with your comments and suggestions for improvement.

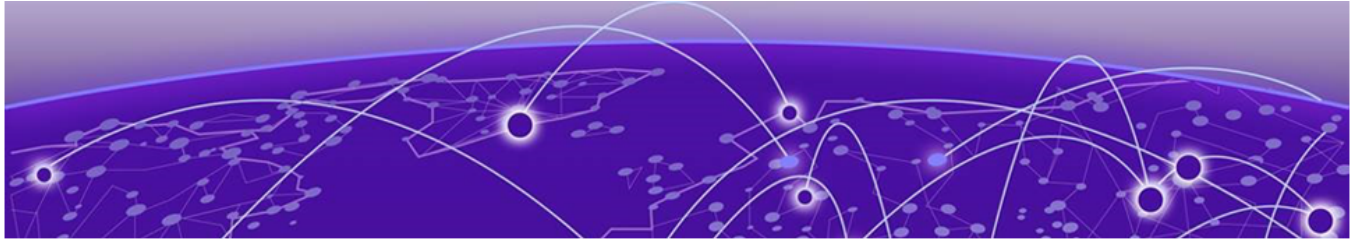

About This Document

[What's New in This Document](#) on page 15

[Supported Platforms](#) on page 17

What's New in This Document

The following table describes the information added to this guide for Extreme OS ONE Switching and Routing, release 22.2.2.0:

Feature	Description	Link
IPv4 ICMP Rate Limiting on the Management Interface	<p>Updated "IPv4 Addressing Show and Clear Commands" topic:</p> <ul style="list-style-type: none"> • Introduces the show counters icmp interface management command, which displays statistics for the management interface. These include the aggregated numbers of IPv4 ICMP packets that the system accepted or dropped because of ICMP rate limiting. • Introduces the clear counters interface management command, which clears statistics for the management interface. These include the aggregated numbers of IPv4 ICMP packets that the system accepted or dropped because of ICMP rate limiting. 	IPv4 Addressing Show and Clear Commands on page 35
	<p>New "IPv4 ICMP Rate Limiting on the Management Interface" topic provides an overview of how to control and monitor IPv4 ICMP echo-request (ping) traffic on the management interface to protect the device from ping flooding attacks and excessive IPv4 ICMP traffic that could impact device performance.</p>	IPv4 ICMP Rate Limiting on the Management Interface on page 35

Feature	Description	Link
IPv6 ICMP Rate Limiting on the Management Interface	Updated "Displaying Global IPv6 Information" topic introduces a step for using the show counters icmp interface management command, which displays IPv6 statistics for the management interface. These include the aggregated numbers of IPv6 ICMP packets that the system accepted or dropped because of ICMP rate limiting.	Display Global IPv6 Information on page 50
	New "IPv6 ICMP Rate Limiting on the Management Interface" topic provides an overview of how to control and monitor IPv6 ICMP echo-request (ping) traffic on the management interface to protect the device from ping flooding attacks and excessive IPv6 ICMP traffic that could impact device performance.	IPv6 ICMP Rate Limiting on the Management Interface on page 50
	Updated "Clearing Global IPv6 Information" topic introduces a step for using the clear counters interface management command, which clears IPv6 statistics for the management interface. These include the aggregated numbers of IPv6 ICMP packets that the system accepted or dropped because of ICMP rate limiting.	Clear Global IPv6 Information on page 52

For more information, see the *Extreme OS ONE SR Release Notes*.

Supported Platforms

Extreme OS ONE Switching and Routing 22.2.1.0 and later releases support Extreme 8520, Extreme 8720, Extreme 8730, and Extreme 8820 hardware platforms.

**Note**

Although many software and hardware configurations are tested and supported for this release, all possible configurations and scenarios are beyond this document's scope.

For information about other releases, see the documentation for those releases.

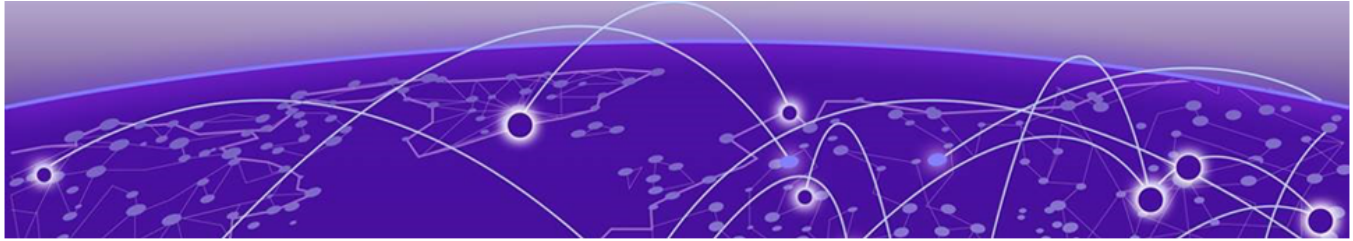

IPv4 Addressing

- [IPv4 Addressing Overview](#) on page 18
- [Virtual Routing and Forwarding \(VRF\)](#) on page 20
- [Load Balancing \(Hashing\)](#) on page 22
- [IP Parameters and Protocols](#) on page 24
- [Address Resolution Protocol](#) on page 24
- [Assign an IPv4 Address to a Loopback Interface](#) on page 28
- [Assign IPv4 addresses to Non-Loopback Interfaces](#) on page 28
- [IPv4 Management](#) on page 30
- [Delete an IP Address from an Interface](#) on page 32
- [The Domain Name System](#) on page 32
- [Configure the Source IP Address for Various Packet Types](#) on page 34
- [IPv4 ICMP Rate Limiting on the Management Interface](#) on page 35
- [IPv4 Addressing Show and Clear Commands](#) on page 35

The following topics describe how to configure IPv4 addressing.

IPv4 Addressing Overview

IPv4 uses a 32-bit addressing system designed for use in packet-switched networks. IPv4 routing is enabled by default on Extreme OS ONE devices that operate at Layer 3 and cannot be disabled.

IPv4 is an Internet protocol used to deliver packets of data from a source to a destination across an interconnected system of networks. IPv4 uses a fixed-length 32-bit addressing system and is represented in a 4-byte dotted decimal format: x.x.x.x.

IP uses four main mechanisms to provide service:

- **Type of Service (ToS)**—Quality of Service (QoS) required for a specific traffic type or network and configures a higher priority to be given to voice traffic, for example, that is more sensitive to dropped packets.
- **Time to Live (TTL)**—Time period for which a packet can exist before it reaches its final destination. If the TTL expires before the packet reaches its destination, the packet is destroyed. The period is set by the packet sender.
- **Options**—Control mechanisms such as timestamps, security, and other special routing functions that are optional.
- **Header Checksum**—Verification that the packet contents transmitted correctly. If the checksum algorithm fails, the packet is dropped immediately.

An IP address has two sections:

- **Network**—Network on which the device is configured.
- **Host**—Host device.

IPv4 does not provide a reliable communication function. No acknowledgments are sent, and the only error control is the header checksum. There are no flow control mechanisms or retransmissions. Internet Control Message Protocol (ICMP) can be used to report any errors.

IP interfaces

Extreme OS ONE devices that operate at Layer 3 allow IPv4 addresses to be configured on the following types of interfaces (and subinterfaces):

- Ethernet ports
- VE interfaces
- Port channel (LAG) interfaces
- Loopback interfaces

You can configure up to 128 IP addresses on each interface (or subinterface).



Note

After you configure a port as part of a bridge domain, you cannot configure Layer 3 interface parameters on that port. The parameters must be configured on the appropriate virtual routing interface.

ARP Cache

The ARP cache contains entries that map IP addresses to MAC addresses.

Entries to the Address Resolution Protocol (ARP) cache are added from:

- Devices that are directly attached to the Layer 3 device.
- An interface based static IP route that goes to a destination two or more router hops away. The MAC address is either of the destination device or the router interface answering an ARP request on behalf of the device, using proxy ARP.

The ARP cache can contain both dynamic (learned) entries and static (user-configured) entries. The software places an entry in the ARP cache:

- **Dynamic**—When the Layer 3 device learns a device MAC address from an ARP request or ARP reply from the device.
- **Static**—When the interface with a proper IP address comes up.

The ARP cache also contains the ARP entries learned from MLAG and EVPN.

For more information about ARP, see [ARP Overview](#) on page 25.

Virtual Routing and Forwarding (VRF)

You use VRFs to set up multiple independent routing tables within a single Layer 3 device. VRFs route traffic between VLANs assigned to the VRF, simulating multiple networks on one router. This provides enhanced security and separation.

VRF configuration requires the following items:

- Unicast: Provides IPv4 VPN instance on the VRF (required for other features)
- Multicast: Provides Layer 3 VSN IP Multicast over Fabric Connect for the VRF (required for other features)
- Direct Route: Sets up route redistribution for the VRF
- Default Gateway: Configures a default gateway for the VRF
- DvR Redistribution: Controls route redistribution over DvR

Sample VRF Configuration

The following example shows a typical configuration for a VRF (in this case, the default VRF). In this example, the **member** (VRF configuration) command attaches 12 interfaces to the VRF. All IPv4 and IPv6 addressing becomes active only when interfaces are attached to a VRF:

```
device# show running-config vrf default-vrf

vrf default-vrf
 member ethernet 0/15
 member ethernet 0/15 vlan 4094
 member ethernet 0/21
 member ethernet 0/29 vlan 4094
 member port-channel 1
 member port-channel 16
 member port-channel 16 vlan 1,4094
 member port-channel 26
 member port-channel 26 vlan 4094
 member port-channel 46
 member ve 600,800,7000
 member loopback 1-2,1024
 ecmp-max-path 32
 resilient-hash
 table-connections
   src-protocol connected dst-protocol bgp address-family ipv4
 !
 evpn-instance tenant_1
   nve nvel
   ignore-as
   bridge-domain 11,1001,2000,4000,4500,4901,5000,6000,7000,8192
 static-route 192.0.2.163/32 192.0.2.1
 !
 router bgp
   local-as 65001
   router-id 198.51.100.254
   graceful-restart
   use-multiple-paths ebgp maximum-paths 10
   address-family ipv4 unicast
     graceful-restart
     network 192.0.2.0/24
     network 198.51.100.0/24
```

```

network 203.0.113.6/32
activate
!
address-family ipv6 unicast
network 2001:db8:1::/64
network 2001:db8:2::/64
network 2001:db8:3::1/128
activate
!
address-family l2vpn evpn
graceful-restart
activate
!
peer-group group1
remote-as 65124
enable-bfd
address-family ipv6 unicast
activate
!
!
peer-group group2
remote-as 65001
nvo ispl_nvo
enable-bfd
address-family ipv4 unicast
activate
!
address-family l2vpn evpn
activate
!
!
peer-group group3
remote-as 65124
nvo ispl_nvo
enable-bfd
address-family ipv4 unicast
activate
!
address-family l2vpn evpn
nexthop-unchanged
activate
!
!
!
device#

```

IP Addressing

IP addressing is scoped within each VRF as follows:

- Each VRF has its own IP address space and Layer 3 interfaces.
- IP addresses are assigned per VRF, allowing reuse of the same IP in different VRFs without conflict.
- IP interfaces are bound to a specific VRF (for example, `interface vlan 100 vrf Customer-A`).

Static Routing

Static routes are created and maintained separately per VRF. Each VRF has its own routing table, and routes are not visible across VRFs unless leaked.

ECMP Maximum Paths

You use ECMP to set up multiple paths to forward traffic to the same destination. ECMP support in VRF provides load balancing and redundancy within a VRF and distributes traffic across multiple paths to the same destination.

The following example shows the **ecmp-max-path** command, which configures the ECMP feature to set the number of paths:

```
device(config)# vrf default-vrf
device(config-vrf-default-vrf)# ecmp-max-path
(2-128) Specify the maximum ECMP paths (range: 2-128, power of 2, default: 8)
device(config-vrf-default-vrf)#
```

Resilient Hashing

Resilient hashing ensures consistent traffic distribution across ECMP paths, even when paths change. With VRF and ECMP, it ensures consistent traffic distribution across ECMP paths and minimizes traffic disruption and maintains predictable traffic redistribution.

Combining VRF, ECMP, and Resilient Hashing creates a scalable and resilient network infrastructure to support complex routing requirements.

Load Balancing (Hashing)

Load balancing (hashing) is a method of distributing traffic between interfaces that are tied to the same group to use all the links efficiently. The goal is to provide both redundancy and increased throughput while ensuring that packets within the same "flow" are not reordered.

Configure Ethernet Load Balancing

Ethernet load balancing is done via the Ethernet header fields such as SRC MAC, DST MAC, Ether Type, and VLAN. The Ethernet load balancing configuration is applied globally (device-wide).

All Ethernet load balancing options are enabled for Ethernet by default. To disable one or more options, use the **no** form of the **load-balance ethernet** command.

For details about the commands in this section, see the *Extreme OS ONE SR Command Reference Guide*.

1. From privileged EXEC mode, access global configuration mode.

```
device# configure terminal
```

2. Configure Ethernet load balancing parameters on the device. You can specify one or more of the following parameters in any combination and in any order: { [**dst-mac**] [**etype**] [**src-mac**] [**vlan**] }

```
device(config)# load-balance ethernet dst-mac etype src-mac vlan
```

3. Verify the configuration.

```
device(config)# do show running-config load-balance

load-balance ethernet dst-mac src-mac vlan etype
load-balance ipv4 dst-ip dst-l4-port protocol src-ip src-l4-port
load-balance ipv6 dst-ip dst-l4-port nxt-hdr src-ip src-l4-port
!
device#
```

Configure Layer 3 Load Balancing

Layer 3 IPv4 load balancing is done via the Layer 3 IPv4 header fields such as SRC IP, DST IP, and Protocol. Layer 3 IPv6 load balancing is performed using the Layer 3 IPv6 header fields such as SRC IPV6, DST IPV6 and Nxt-hdr. The Layer 3 load balancing configuration is applied globally (device-wide).

All load balancing options are enabled for Layer 3 (IPv4 and IPv6) by default. To disable one or more options, use the **no** form of the **load-balance ipv4** command or the **load-balance ipv6** command respectively.

For details about the commands in this section, see the *Extreme OS ONE SR Command Reference Guide*.

1. From privileged EXEC mode, access global configuration mode.

```
device# configure terminal
```

2. Configure IPv4 load balancing parameters on the device. You can specify one or more of the following parameters in any combination and in any order: { [**dst-ip**] [**protocol**] [**src-ip**] }

```
device(config)# load-balance ipv4 dst-ip protocol src-ip
```

3. Configure IPv6 load balancing parameters on the device. You can specify one or more of the following parameters in any combination and in any order: { [**dst-ip**] [**next-hdr**] [**src-ip**] }

```
device(config)# load-balance ipv6 dst-ip nxt-hdr src-ip
```

4. Verify the configuration.

```
device(config)# do show running-config load-balance

load-balance ethernet dst-mac src-mac vlan etype
load-balance ipv4 dst-ip dst-l4-port protocol src-ip src-l4-port
load-balance ipv6 dst-ip dst-l4-port nxt-hdr src-ip src-l4-port
!
device#
```

Configure Layer 4 Load Balancing

All load balancing options are enabled for Layer 4 (IPv4 and IPv6) by default. To disable one or more options, use the **no** form of the **load-balance ipv4** command or the **load-balance ipv6** command respectively.

For details about the commands in this section, see the *Extreme OS ONE SR Command Reference Guide*.

1. From privileged EXEC mode, access global configuration mode.

```
device# configure terminal
```

2. Configure IPv4 load balancing parameters on the device. You can specify one or more of the following parameters in any combination and in any order: { [**dist-l4-port**] [**protocol**] [**src-l4-port**] }

```
device(config)# load-balance ipv4 dist-l4-port protocol src-l4-port
```

3. Configure IPv6 load balancing parameters on the device. You can specify one or more of the following parameters in any combination and in any order: { [**dist-l4-port**] [**next-hdr**] [**src-l4-port**] }

```
device(config)# load-balance ipv6 dist-l4-port nxt-hdr src-l4-port
```

4. Verify the configuration.

```
device(config)# do show running-config load-balance

load-balance ethernet dst-mac src-mac vlan etype
load-balance ipv4 dst-ip dst-l4-port protocol src-ip src-l4-port
load-balance ipv6 dst-ip dst-l4-port nxt-hdr src-ip src-l4-port
!
device#
```

IP Parameters and Protocols

Most IP parameters are dynamic. They take effect as soon as you run the CLI command. You can verify that a dynamic change has taken effect by displaying the running configuration. To do so, use the **show running-config** command.

To change the memory allocation, reload the software after you save the changes to the startup configuration file.

The system disables the BGP4 route exchange protocol and multicast protocols (IGMP) by default.

Address Resolution Protocol

The following topics describe how to configure Address Resolution Protocol (ARP). These topics include instructions for setting how long a device considers another device to be reachable after successfully contacting it as well as instructions for creating static ARP entries to ensure reliable, secure, and controlled IP-to-MAC mapping (useful for security, troubleshooting, legacy support, or network enforcement).

ARP Overview

The Address Resolution Protocol (ARP) maps IPv4 network addresses to MAC hardware addresses.

When forwarding traffic, a device needs to know the destination MAC address because each IP packet is encapsulated in an Ethernet frame. The MAC address is needed for the packet's final destination and for a next hop toward the destination.

A device first searches its ARP cache, and a match for the IP address supplies the corresponding MAC address. Otherwise, the device broadcasts an ARP request. Network devices receive the requests, and the host with a matching IP address sends an ARP reply that includes its MAC address.

After the device receives a matching ARP reply, the packet is sent toward its destination, and the IP address/MAC address pair is added to the ARP cache as a dynamic ARP entry.

Configure ARP Reachable Time for Remote IPv4 Nodes

You can configure the duration (in seconds) that a router considers a remote IPv4 node to be reachable. You can configure ARP reachable time for Ethernet, port channel (LAG), and Virtual Ethernet (VE) interfaces as well as Ethernet and port channel subinterfaces.

To do so, you use the **ipv4 neighbor reachable-time** command to configure the ARP IPv4 neighbor reachable-time configuration on an interface. ARP establishes correspondences between pairs of network-layer (Layer 3) addresses and LAN hardware addresses (Layer 2 MAC addresses).

Router advertisement messages include a *reachable time* value. All nodes on a link use the same value.

Reachable time is how long a device considers another device to be reachable after successfully contacting it without re-verifying its presence. When a device sends traffic to a neighbor and receives a response, it marks that neighbor as reachable.

The reachable time is a timer that specifies how long the entry stays in the reachable state before the device must probe or refresh the neighbor information. If no additional communication happens during the reachable time, the device transitions the neighbor entry to a stale state and eventually needs to verify it again using an ARP request.

Extreme Networks recommends that you configure a long duration, because a short duration causes IPv4 network devices to process the information at a greater frequency.

1. Access global configuration mode.

```
device# configure terminal
```

2. Access the interface on which you are changing the reachable time.

```
device(config)# interface ethernet 0/1
```

3. Specify the new reachable time value.

```
device(config-if-eth-0/1)# ipv4 neighbor reachable-time 300
```

Valid values range from 30 through 3600 seconds. The default is 1200 seconds.

The following examples show how to configure ARP reachable time for Ethernet, port channel (LAG), and Virtual Ethernet (VE) interfaces as well as Ethernet and port channel subinterfaces respectively:

```
device# configure terminal
device(config)# interface ethernet 0/1
device(config-if-eth-0/1)# ipv4 neighbor reachable-time 300
device(config-if-eth-0/1)#

device# configure terminal
device(config)# interface port-channel 10
device(config-if-po-10)# ipv4 neighbor reachable-time 600
device(config-if-po-10)#

device# configure terminal
device(config)# interface ve 100
device(config-if-ve-100)# ipv4 neighbor reachable-time 1500
device(config-if-ve-100)#

device# configure terminal
device(config)# interface ethernet 0/1
device(config-if-eth-0/1)# subinterface vlan 100
device(config-subif-eth-0/1.100)# ipv4 neighbor reachable-time 2500
device(config-subif-eth-0/1.100)#

device# configure terminal
device(config)# interface port-channel 10
device(config-if-po-10)# subinterface vlan 200
device(config-subif-po-10.200)# ipv4 neighbor reachable-time 3600
device(config-subif-po-10.200)#
```

The following example displays the configuration of Ethernet interface 0/1 that is running currently on the device. In this example, the reachable time is set to 300 seconds on the interface:

```
device# show running-config interface ethernet 0/1

interface ethernet 0/1
  mtu 1600
  ipv4 neighbor reachable-time 300
  no shutdown
  !
device#
```

Configure a Static ARP Entry for an Interface

A static entry in the IPv4 Address Resolution Protocol (ARP) cache ensures that an IPv4 neighbor is always reachable. You can create a static ARP entry for a device that is not yet connected to the network or to prevent an entry from aging out. You can configure static ARP entries for Ethernet, port channel (LAG), and Virtual Ethernet (VE) interfaces as well as Ethernet and port channel subinterfaces.

1. Access global configuration mode.

```
device# configure terminal
```

2. Specify the interface to contain the static ARP entry.

```
device(config)# interface ethernet 0/1
```

3. Create the static ARP entry for the neighbor.

```
device(config-int-eth-0/1)# ipv4 neighbor 192.0.2.0 3c:fd:fe:e4:xx:a8
```

This example creates a static ARP entry for a neighbor with IPv4 address 1.1.1.10 and associates it with MAC address 3c:fd:fe:e4:37:a8, reachable through physical port Ethernet 0/1.

The following example displays the configuration of Ethernet interface 0/1 that is running currently on the device. In this example, the ARP IPv4 address and MAC address on the interface are set to 1.1.1.10 and 3c:fd:fe:e4:37:a8 respectively:

```
device# show running-config interface ethernet 0/1

interface ethernet 0/1
  ipv4 address 192.0.2.0/24
  ipv4 neighbor 192.0.2.1 3c:fd:fe:e4:yy:xx
  no shutdown
!
device#
```

The following examples show how to configure static ARP entries for Ethernet, port channel (LAG), and Virtual Ethernet (VE) interfaces as well as Ethernet and port channel subinterfaces respectively:

```
device# configure terminal
device(config)# interface ethernet 0/1
device(config-if-eth-0/1)# ipv4 neighbor 192.0.2.0 3c:fd:fe:ex:xx:a5
device(config-if-eth-0/1)#

device# configure terminal
device(config)# interface port-channel 10
device(config-if-po-10)# ipv4 neighbor 192.0.2.1 3c:fd:fe:cv:xx:a6
device(config-if-po-10)#

device# configure terminal
device(config)# interface ve 100
device(config-if-ve-100)# ipv4 neighbor 192.0.2.2 3c:fd:fe:e4:xx:ax
device(config-if-ve-100)#

device# configure terminal
device(config)# interface ethernet 0/1
device(config-if-eth-0/1)# subinterface vlan 100
device(config-subif-eth-0/1.100)# ipv4 neighbor 192.0.2.3 3c:fd:fe:ex:xx:a8
device(config-subif-eth-0/1.100)#

device# configure terminal
device(config)# interface port-channel 10
device(config-if-po-10)# subinterface vlan 200
device(config-subif-po-10.200)# ipv4 neighbor 192.0.2.4 3c:fd:ff:ee:xx:aa
device(config-subif-po-10.200)#
```

Assign an IPv4 Address to a Loopback Interface

IPv4 addresses can be assigned to a loopback interface via Classless Interdomain Routing (CIDR) network masks. Loopback interfaces add stability to a network, because they do not incur route flap problems due to unstable links between devices.

IPv4 routing is enabled by default on Extreme OS ONE devices that operate at Layer 3 and cannot be disabled. IP addresses must be assigned to interfaces on the devices to allow IPv4 based protocols to operate across the network.

1. From privileged EXEC mode, access global configuration mode.

```
device# configure terminal
```

2. Access the interface to which you are assigning the IP addresses.

```
device(config)# interface loopback 1
```

3. Assign an IP address to the interface.



Note

You can define only one IP address per loopback. The only valid mask value is /32.

```
device(config-if-lo-1)# ipv4 address 192.0.2.0/32
```

4. Activate the interface.

```
device(config-if-lo-1)# no shutdown
```

5. Add the interface to a VRF.

```
device(config-if-lo-1)# exit
device(config)# vrf default-vrf
device(config-vrf-default-vrf)# member loopback 1
```

6. Verify that the IP address is assigned to the interface.

```
device(config-vrf-default-vrf)# do show ipv4 interface loopback 1

Interface: Lo 1 Admin-status:UP Oper-status:UP
IP MTU: 1500
Vrf:default-vrf
Address      Status
=====
192.0.2.0/32 PREFERRED
device(config-vrf-default-vrf)#
```

Assign IPv4 addresses to Non-Loopback Interfaces

IPv4 addresses (primary or secondary) can be assigned to interfaces or subinterfaces, using Classless Interdomain Routing (CIDR) network masks. You can assign IPv4 addresses to Ethernet, port channel (LAG), and Virtual Ethernet (VE) interfaces as well as Ethernet and port channel subinterfaces.

1. Access global configuration mode.

```
device# configure terminal
```

2. Access the interface to which you are assigning the IP addresses.

```
device(config)# interface ethernet 0/1
```

- Assign one or more IP addresses with a CIDR network mask.

```
device(config-if-eth-0/1)# ipv4 address 192.0.2.0/24
device(config-if-eth-0/1)# ipv4 address 192.0.2.1/24
```

This example assigns IPv4 address 192.0.2.0 and CIDR network mask /24 to interface Ethernet 0/1 and also assigns IPv4 address 192.0.2.1 and CIDR network mask /24 to the same interface.

- To assign a secondary IPv4 address with a CIDR network mask, include the **secondary** keyword.



Note

You can configure a secondary IPv4 address only if the primary IPv4 address is already configured in the same subnet.

```
device(config-if-eth-0/1)# ipv4 address 192.0.2.2/24 secondary
```

- Activate the interface.

```
device(config-if-eth-0/1)# no shutdown
```

- Add the interface to a VRF.

```
device(config-if-eth-0/1)# exit
device(config)# vrf red
device(config-vrf-red)# member loopback 1
```

- Verify that the IPv4 addresses are assigned to the interface.

```
device(config-vrf-red)# do show ipv4 interface ethernet 0/1

Interface: Eth 0/1 Admin-status:UP Oper-status:UP
IP MTU: 1500
Vrf: red
Address                Status
=====
192.0.2.0/24           PREFERRED
192.0.2.1/24           PREFERRED
192.0.2.2/24 (secondary) PREFERRED
device#
```

The following example displays the configuration of Ethernet interface 0/1 that is running currently on the device. In this example, IPv4 address 1.1.1.1 and CIDR network mask /24 are assigned to interface Ethernet 0/1:

```
device# show running-config interface ethernet 0/1

interface ethernet 0/1
  ipv4 address 192.0.2.0/24
  ipv4 neighbor 192.0.2.1 3c:fd:fe:e4:xx:a8
  no shutdown
!
device#
```

The following examples show how to configure IPv4 addresses with CIDR network masks to Ethernet, port channel (LAG), and Virtual Ethernet (VE) interfaces as well as Ethernet and port channel subinterfaces respectively:

```
device# configure terminal
device(config)# interface ethernet 0/1
device(config-if-eth-0/1)# ipv4 address 192.0.2.0/24
device(config-if-eth-0/1)#

device# configure terminal
device(config)# interface port-channel 10
```

```
device(config-if-po-10)# ipv4 address 192.0.2.1/24
device(config-if-po-10)#

device# configure terminal
device(config)# interface ve 100
device(config-if-ve-100)# ipv4 address 192.0.2.2/24
device(config-if-ve-100)#

device# configure terminal
device(config)# interface ethernet 0/1
device(config-if-eth-0/1)# subinterface vlan 100
device(config-subif-eth-0/1.100)# ipv4 address 192.0.2.3/24
device(config-subif-eth-0/1.100)#

device# configure terminal
device(config)# interface port-channel 10
device(config-if-po-10)# subinterface vlan 200
device(config-subif-po-10.200)# ipv4 address 192.0.2.4/24
device(config-subif-po-10.200)#
```

The following examples show how to use the secondary keyword to configure secondary IPv4 addresses with CIDR network masks to Ethernet, port channel (LAG), and Virtual Ethernet (VE) interfaces as well as Ethernet and port channel subinterfaces respectively:

```
device# configure terminal
device(config)# interface ethernet 1/1
device(config-if-eth-1/1)# ipv4 address 192.0.2.5/24 secondary
device(config-if-eth-1/1)#

device# configure terminal
device(config)# interface port-channel 5
device(config-if-po-5)# ipv4 address 192.0.2.6/24 secondary
device(config-if-po-5)#

device# configure terminal
device(config)# interface ve 50
device(config-if-ve-50)# ipv4 address 192.0.2.7/24 secondary
device(config-if-ve-50)#

device# configure terminal
device(config)# interface ethernet 0/2
device(config-if-eth-0/2)# subinterface vlan 50
device(config-subif-eth-0/2.50)# ipv4 address 192.0.2.8/24 secondary
device(config-subif-eth-0/2.50)#

device# configure terminal
device(config)# interface port-channel 4
device(config-if-po-4)# subinterface vlan 75
device(config-subif-po-4.75)# ipv4 address 192.0.2.9/24 secondary
device(config-subif-po-4.75)#
```

IPv4 Management

This section describes the Ping and Traceroute tools. These are both network diagnostic tools, but they serve different purposes and provide different insights into network connectivity. You use Ping to check if a host is up, quickly test latency, or verify DNS name resolution. You use Traceroute to troubleshoot slow or dropped connections, determine if a specific hop or route is causing issues, or map the path from source to destination.

IPv4 Ping

The **ping** command verifies connectivity from an Extreme OS ONE device to an IPv4 destination on a TCP/IP network. This command is a diagnostic tool used to test connectivity between your device and another network host. It tells you whether the target is reachable and how long it takes to respond.

This command sends a specified number of pings with configured parameters to the specified IPv4 destination device. Optional parameters include the datagram size, interface name, source address, time (in seconds) to wait for a response, and VRF instance name.

A ping displays information for the device as soon as the information is received. This includes the number of packets transmitted and received, percentage of packets lost, and elapsed time.

You can specify that the device display up to 1000 transmissions (pings). The range is 1 through 1000.

For more information about the command, including examples, see the *Extreme OS ONE SR Command Reference Guide*.

The following example pings an IPv4 destination address:

```
device# ping 192.0.2.0 vrf mgmt-vrf

PING 192.0.2.0 (192.0.2.0) 56(84) bytes of data.
64 bytes from 192.0.2.0 icmp_seq=1 ttl=54 time=304 ms
64 bytes from 192.0.2.0 icmp_seq=2 ttl=54 time=304 ms
64 bytes from 192.0.2.0 icmp_seq=3 ttl=54 time=303 ms
device#
```

The following example pings an IPv4 destination address in quiet mode:

```
device# ping 192.0.2.0 vrf mgmt-vrf quiet

PING 192.0.2.0 (192.0.2.0) from 192.0.2.1 default-vrf: 56(84) bytes of data.

--- 192.0.2.0 ping statistics ---
5 packets transmitted, 5 received, 0% packet loss, time 4089ms
device#
```

IPv4 Traceroute

The **traceroute** command displays the path of network packets from a Extreme OS ONE device to an IPv4 host. Traceroute is a network diagnostic tool used to track the path that packets take from your device to a destination IP address or hostname. It shows each hop (router or gateway) that the packet goes through to help identify where delays or failures occur in the network.

A traceroute displays information for each hop as soon as the information is received. Optional parameters include an interface name, minimum and maximum Time to Live (TTL) values in a number of hops, source address, time (in seconds) to wait for a response, and VRF instance name.

The **traceroute** command lets you configure a minimum TTL setting between 1 and 255 hops (the default is 1 hop). It also lets you configure a maximum TTL setting between 1 and 255 hops (the default is 30 hops).

The device displays up to three responses when there are multiple equal-cost routes to the destination.

The following example executes an IPv4 traceroute:

```
device# traceroute 192.0.2.0

traceroute to 192.0.2.0 (192.0.2.0), 30 hops max, 60 byte packets
 1 192.0.2.0 (192.0.2.0) 0.075 ms 0.019 ms 0.017 ms
device#
```

The following example executes an IPv4 traceroute for a VRF named vrf1. The output shows two hops:

```
device# traceroute 192.0.2.0 vrf vrf1

traceroute to 192.0.2.0 (192.0.2.0), 30 hops max, 60 byte packets
 1 192.0.2.1 (192.0.2.1) 1.033 ms 0.950 ms 0.889 ms
 2 192.0.2.0 (192.0.2.0) 0.851 ms 0.809 ms 0.766 ms
device#
```

Delete an IP Address from an Interface

You can delete a specified IP address, or all IP addresses, from an interface or subinterface.

1. From privileged EXEC mode, access global configuration mode.

```
device# configure terminal
```

2. Access the interface from which you are deleting the IP address.

```
device(config)# interface ethernet 0/2
```

3. To delete a specific IP address from the interface, run the **no ipv4 address** command with the IP address and the mask.

```
device(config-if-eth-0/2)# no ipv4 address 192.0.2.0/24
```

4. To delete all IP addresses from the interface, run the **no ipv4 address** command.

```
device(config-if-eth-0/2)# no ipv4 address
```

The Domain Name System

The Domain Name System (DNS) is a hierarchical naming system that assigns a name (such as a company name) to an Internet entity to represent the real IP address of the entity. An entity can be a gateway router and is referred to as a domain.

A domain name (for example, extreme.router.com) can be used in place of an IP address for certain operations such as IP pings, traceroutes, and Telnet management connections to the router. A domain name is easier to remember than all of the numbers in an IP address. DNS has several components:

- DNS server: A DNS server stores the information about a DNS domain. DNS servers are a key element of DNS because they respond to queries against its database.

When a DNS domain is defined on this device to recognize all hosts in that domain, this device automatically appends the appropriate domain to the host address and forwards it to the DNS server.

- **DNS resolver:** In a Layer 2 or Layer 3 device, the DNS resolver sends and receives queries to and from the DNS server on behalf of a client. You can create a list of domain names that can be used to resolve host names. This list can have more than one domain name. When a client performs a DNS query, all hosts in the domains in the list can be recognized and queries can be sent to any domain on the list. After you define a domain name, the device automatically appends the appropriate domain to a host and forwards it to the DNS servers for resolution.
- **DNS gateway addresses:** Gateway IP addresses that are assigned to the device enable clients that are attached to the device to reach DNS.

Configure a DNS Domain and Gateway Addresses

You can configure a DNS domain and DNS gateway addresses to resolve host names to IP addresses.

1. Access global configuration mode.

```
device# configure terminal
```

2. Access system configuration mode.

```
device(config)# system
```

3. Access DNS configuration mode.

```
device(config-system)# dns
```

4. Configure one or more domain names.

```
device(config-system-dns)# domain-name mydevice1.com
device(config-system-dns)# domain-name mydevice2.com
```

5. Configure one or more DNS gateway addresses for DNS servers.

```
device(config-system-dns)# name-server 192.0.2.0
device(config-system-dns)# name-server 192.0.2.0
```

The first DNS server IP address added to the domain name configuration will be considered the primary DNS server. You can add up to five additional DNS servers for the domain name. Any combination of IPv4 or IPv6 DNS name servers can be configured. For example, you could add two IPv6 name servers alongside four IPv4 name servers. However, you cannot add more than six name servers for the domain.

If you add more than six name servers for the domain, the following error message appears:

```
too many 'ip dns name-server', 7 configured, at most 6 must be configured
```

6. Return to privileged EXEC mode.

```
device(config-system-dns)# end
```

7. (Optional) Verify the DNS configuration.

```
device# traceroute mydevice1.com

Sending DNS Query to 192.0.2.0
Tracing Route to IP node 192.0.2.1
To ABORT Trace Route, Please use stop-traceroute command.
```

```
Traced route to target IP node 192.0.2.0:
IP Address      Round Trip Time1    Round Trip Time2
192.0.2.1      93 msec             121 msec
```

The output shows that 192.0.2.0 is the IP address of the DNS server (default DNS gateway address), and 192.0.2.1 represents the IP address of the mydevice1.com host.

The following example configures six DNS name servers for the domain *www.mydevice1.com*. Of these six domain names, two are IPv6 DNS resolvers:

```
device# configure terminal
device(config)# system
device(config-system)# dns
device(config-system-dns)# domain-name www.mydevice1.com
device(config-system-dns)# name-server 192.0.2.0
device(config-system-dns)# name-server 192.0.2.1
device(config-system-dns)# name-server 192.0.2.2
device(config-system-dns)# name-server 2001:db8:0:53::1
device(config-system-dns)# name-server 2001:db8:0:53::2
device(config-system-dns)# name-server 192.0.2.3
device(config-system-dns)#
```

Configure the Source IP Address for Various Packet Types

When a device originates a packet of one of the following types, the default source address of the packet is the lowest-numbered IP address on the interface that sends the packet:

- Telnet
- TACACS or TACACS+
- TFTP
- RADIUS
- Syslog
- SMTP

You can configure the device to always use the lowest-numbered IP address on a specific Ethernet, loopback, or Virtual Ethernet (VE) interface as the source addresses for these packets. When configured, the device uses the same IP address as the source for all packets of the specified type regardless of the ports that actually sends the packets.

Designating a source IP address provides the following benefits:

- If your server is configured to accept packets only from specific IP addresses, you can configure the device to always send the packets from the same link or source address.
- If you specify a loopback interface as the single source for specified packets, servers can receive the packets regardless of the states of individual links. Thus, if a link to the server becomes unavailable but can be reached through another link, the client or server still receives the packets, and the packets still have the source IP address of the loopback interface.

IPv4 ICMP Rate Limiting on the Management Interface

IPv4 Internet Control Message Protocol (ICMP) rate limiting lets you control and monitor IPv4 ICMP echo-request (ping) traffic on the management interface. This protects the device from ping flooding attacks and excessive IPv4 ICMP traffic that could impact device performance.

This feature ensures device manageability by allowing necessary diagnostics while dropping excessive traffic. It specifically throttles IPv4 ICMP traffic to allow safe troubleshooting without affecting management traffic such as SSH or HTTPS.

ICMP rate limiting on the management interface in IPv4 functions the same as it does in IPv6. For details about configuring and monitoring IPv4 ICMP rate limiting on the management interface, see the *Extreme OS ONE SR Security Configuration Guide*.

IPv4 Addressing Show and Clear Commands

You can display and delete information related to IPv4 interfaces and routes.

[Table 4](#) shows a list of **show** and **clear** commands that you can use to display or delete information about IPv4 interfaces and routes.

Table 4: IPv4 addressing show and clear commands

Command	Description
show ipv4 interface [ethernet <i>interface-name</i> loopback <i>port-number</i> port-channel <i>port-channel-number</i> tunnel <i>interface-name</i> ve <i>interface-name</i> internal <i>interface-name</i>] [brief]	Displays the IPv4 address, status, and configuration for a specified Ethernet, loopback, or Virtual Ethernet (VE) interface. You can also display a brief summary of this information for all interfaces.
show ipv4 neighbor vrf { all <i>vrf-name</i> } [<i>ipv4-address</i>]	Displays the address resolution protocol (ARP) entries in the neighbor caches for Virtual Routing and Forwarding (VRF) instances.
show ipv4 route vrf <i>vrf-name</i> [<i>ipv4-address / prefix-length</i>] [connected static arp bgp brief]	Displays IPv4 route information.
show counters icmp interface management <i>interface-name</i>	Displays the aggregated numbers of IPv4 ICMP packets that the system accepted or dropped because of ICMP rate limiting on the management interface. The only supported value for <i>interface-name</i> is 0 in this release. For details about configuring and monitoring IPv4 ICMP rate limiting on the management interface, see the <i>Extreme OS ONE SR Security Configuration Guide</i> .

Table 4: IPv4 addressing show and clear commands (continued)

Command	Description
<code>clear ipv4 route vrf vrf-name [ipv4-address / prefix-length]</code>	Clears a specified IPv4 route or all IPv4 routes in the IP routing tables.
<code>clear counters interface management interface-name</code>	Clears statistics for the management interface. These include the aggregated numbers of IPv4 ICMP packets that the system accepted or dropped because of ICMP rate limiting. The only supported value for <i>interface-name</i> is 0 in this release. For details about configuring and monitoring IPv4 ICMP rate limiting on the management interface, see the <i>Extreme OS ONE SR Security Configuration Guide</i> .

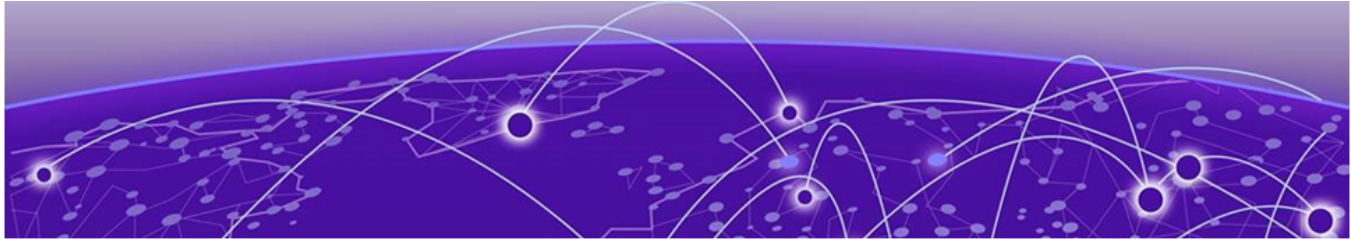

IPv6 Addressing

- [IPv6 Addressing Overview](#) on page 37
- [Assign an IPv6 Address to a Loopback Interface](#) on page 38
- [Assign IPv6 Addresses to Non-Loopback Interfaces](#) on page 39
- [IPv6 Management](#) on page 41
- [IPv6 Neighbor Discovery](#) on page 43
- [IPv6 ICMP Rate Limiting on the Management Interface](#) on page 50
- [Display Global IPv6 Information](#) on page 50
- [Clear Global IPv6 Information](#) on page 52

The following topics describe how to configure IPv6 addressing.

IPv6 Addressing Overview

IPv6 increases the number of network address bits from 32 (IPv4) to 128 bits, which provides more unique IP addresses to support more network devices.

An IPv6 address consists of 8 fields of 16-bit hexadecimal values separated by colons (:). [Figure 1](#) shows the format for IPv6 addresses.

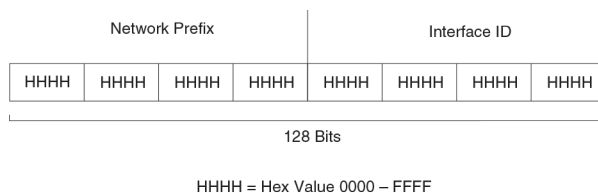

Figure 1: IPv6 address format

As shown in [Figure 1](#), HHHH is a 16-bit hexadecimal value. H is a 4-bit hexadecimal value. An example of an IPv6 address is 2001:db8:0:200:2d:d0ff:fe48:4672.

An IPv6 address can include hexadecimal fields of zeros. To make the address manageable, you can:

- Omit the leading zeros. For example, 2001:db8:0:200:2d:d0ff:fe48:4672.
- Compress the successive groups of zeros at the beginning, middle, or end of an IPv6 address to two colons (::) once per address. For example, 2001:db8::200:2d:d0ff:fe48:4672.

When specifying an IPv6 address in a command syntax, consider the following rules:

- You can use the two colons (::) only once in the address to represent the longest successive hexadecimal fields of zeros.

- The hexadecimal letters in IPv6 addresses are not case sensitive.

As shown in [Figure 1](#) on page 37, the IPv6 network prefix consists of the leftmost bits of the address. As with an IPv4 address, you can specify the IPv6 prefix using the prefix/prefix-length format, for which the following rules apply:

- You specify the prefix parameter as 16-bit hexadecimal values separated by a colon.
- You specify the prefix-length parameter as a decimal value that indicates the network portion of the IPv6 address.

An example of an IPv6 prefix is 2001:db8:49ea:d088::/64.

IP interfaces

Extreme OS ONE devices that operate at Layer 3 can use IPv6 addresses that you configure on the following types of interfaces (and subinterfaces):

- Ethernet
- VE
- Port channel (LAG)
- Loopback

You can configure up to 128 IP addresses on each interface (or subinterface).



Note

After you configure a port as part of a bridge-domain, you cannot configure Layer 3 interface parameters on that port. The parameters must be configured on the appropriate virtual routing interface.

Assign an IPv6 Address to a Loopback Interface

IPv6 addresses can be assigned to a loopback interface via Classless Interdomain Routing (CIDR) network masks. Loopback interfaces add stability to a network, because they do not incur route flap problems due to unstable links between devices.

IPv6 routing is enabled by default on Extreme OS ONE devices that operate at Layer 3 and cannot be disabled. IP addresses must be assigned to interfaces on the devices to allow IPv6 based protocols to operate across the network.

1. From privileged EXEC mode, access global configuration mode.

```
device# configure terminal
```

2. Access the interface to which you are assigning the IP addresses.

```
device(config)# interface loopback 1
```

3. Assign an IP address to the interface.



Note

You can define only one IP address per loopback. The only valid mask value is /128.

```
device(config-if-lo-1)# ipv6 2001:db8::100/128
```

4. Activate the interface.

```
device(config-if-lo-1)# no shutdown
```

5. Add the interface to a VRF.

```
device(config-if-lo-1)# exit
device(config)# vrf default-vrf
device(config-vrf-default-vrf)# member loopback 1
```

6. Verify that the IP address is assigned to the interface.

```
device(config-vrf-default-vrf)# do show ipv6 interface loopback 1

Interface: Lo 1 Admin-status:UP Oper-status:UP
IP MTU: 1500
Vrf:default-vrf
Address                Status
=====
ipv6 2001:db8::100/128  PREFERRED
device#
```

Assign IPv6 Addresses to Non-Loopback Interfaces

IPv6 addresses (primary or secondary) can be assigned to interfaces or subinterfaces, using Classless Interdomain Routing (CIDR) network masks. You can assign interfaces for Ethernet, port channel (LAG), and Virtual Ethernet (VE) interfaces as well as Ethernet and port channel subinterfaces.

Configuration of IPv6 addresses on an interface (or subinterface) has the following conditions:

- You can have multiple primary IPv6 addresses from different subnets, but not from the same subnet.
- Secondary IPv6 addresses must have the same subnet as the primary addresses.
- You cannot delete primary IPv6 addresses when you have configured a secondary address.
- You cannot add secondary IPv6 addresses when you have configured a primary address.

Perform the following steps to assign IPv6 addresses. The following example is for an Ethernet interface.

1. Enter global configuration mode.

```
device# configure terminal
```

2. Access the interface to which you are assigning the IP addresses.

```
device(config)# interface ethernet 0/2
```

3. Assign one or more primary IP addresses, including the CIDR network mask.

```
device(config-if-eth-0/2)# ipv6 address 2001:db8:102:102::1/64
device(config-if-eth-0/2)# ipv6 address 2001:db8:202:102::1/64
```

4. Assign one or more secondary IP addresses, including the CIDR network mask and the secondary keyword.

```
device(config-if-eth-0/2)# ipv6 address 2001:db8:102:102::2/64 secondary
device(config-if-eth-0/2)# ipv6 address 2001:db8:202:102::2/64 secondary
```

5. Activate the interface.

```
device(config-if-eth-0/2)# no shutdown
```

6. Add the interface to a VRF.

```
device(config-if-eth-0/2)# exit
device(config)# vrf red
device(config-vrf-red)# member loopback 1
```

7. Verify that the IP addresses are assigned to the interface.

```
device(config-vrf-red)# do show ipv6 interface ethernet 0/2

Interface: Eth 0/2 Admin-status:UP Oper-status:UP
IP MTU: 1500
Vrf: red
Address Status
=====
2001:db8:102:102::1/64 PREFERRED
2001:db8:202:102::1/64 PREFERRED
2001:db8:102:102::2/64 (secondary) PREFERRED
2001:db8:202:102::2/64 (secondary) PREFERRED
device#
```

The following example displays the configuration of Ethernet interface 0/1 that is running currently on the device. In this example, IPv6 address 2001:db8:102:102::1/64 and CIDR network mask /64 are assigned to interface Ethernet 0/1:

```
device# show running-config interface ethernet 0/1

interface ethernet 0/1
  ipv6 address 2001:db8:102:102::1/64
  ipv6 neighbor 2001:db8:102:102::9 3c:fd:fe:e4:37:a0
  no shutdown
!
device#
```

The following examples show how to configure IPv6 addresses with CIDR network masks to Ethernet, port channel (LAG), and Virtual Ethernet (VE) interfaces as well as Ethernet and port channel subinterfaces respectively:

```
device# configure terminal
device(config)# interface ethernet 0/1
device(config-if-eth-0/1)# ipv6 address 2001:db8:102:0::1/64
device(config-if-eth-0/1)#

device# configure terminal
device(config)# interface port-channel 10
device(config-if-po-10)# ipv6 address 2001:db8:102:1::1/64
device(config-if-po-10)#

device# configure terminal
device(config)# interface ve 100
device(config-if-ve-100)# ipv6 address 2001:db8:102:2::1/64
device(config-if-ve-100)#

device# configure terminal
device(config)# interface ethernet 0/1
device(config-if-eth-0/1)# subinterface vlan 100
device(config-subif-eth-0/1.100)# ipv6 address 2001:db8:102:3::1/64
device(config-subif-eth-0/1.100)#

device# configure terminal
device(config)# interface port-channel 10
device(config-if-po-10)# subinterface vlan 200
device(config-subif-po-10.200)# ipv6 address 2001:db8:102:4::1/64
device(config-subif-po-10.200)#
```

The following examples show how to use the secondary keyword to configure secondary IPv6 addresses with CIDR network masks to Ethernet, port channel (LAG), and Virtual Ethernet (VE) interfaces as well as Ethernet and port channel subinterfaces respectively:

```
device# configure terminal
device(config)# interface ethernet 0/2
device(config-if-eth-0/2)# ipv6 address 2001:db8:102:10::1/64 secondary
device(config-if-eth-0/2)#

device# configure terminal
device(config)# interface port-channel 5
device(config-if-po-5)# ipv6 address 2001:db8:102:11::1/64 secondary
device(config-if-po-5)#

device# configure terminal
device(config)# interface ve 50
device(config-if-ve-50)# ipv6 address 2001:db8:102:12::1/64 secondary
device(config-if-ve-50)#

device# configure terminal
device(config)# interface ethernet 0/2
device(config-if-eth-0/2)# subinterface vlan 50
device(config-subif-eth-0/2.50)# ipv6 address 2001:db8:102:13::1/64 secondary
device(config-subif-eth-0/2.50)#

device# configure terminal
device(config)# interface port-channel 4
device(config-if-po-4)# subinterface vlan 75
device(config-subif-po-4.75)# ipv6 address 2001:db8:102:14::1/64 secondary
device(config-subif-po-4.75)#
```

IPv6 Management

Ping and Traceroute are both network diagnostic tools, but they serve different purposes and provide different insights into network connectivity. You use Ping to check if a host is up, quickly test latency, or verify DNS name resolution. You use Traceroute to troubleshoot slow or dropped connections, determine if a specific hop or route is causing issues, or map the path from source to destination.



Note

On the management interface of an Extreme OS ONE device, the IPv6 routing functionality is not enabled.

IPv6 Ping

The **ping ipv6** command verifies connectivity from an Extreme OS ONE device to an IPv6 destination on a TCP/IP network. This command is a diagnostic tool used to test connectivity between your device and another network host. It tells you whether the target is reachable and how long it takes to respond.

This command sends a specified number of pings with configured parameters to the specified IPv6 destination device. Optional parameters include the datagram size, interface name, source address, time (in seconds) to wait for a response, and VRF instance name.

A ping displays information for the device as soon as the information is received. This includes the number of packets transmitted and received, percentage of packets lost, and elapsed time.

You can specify that the device display up to 1000 transmissions (pings). The range is 1 through 1000.

For more information about the command, including examples, see the *Extreme OS ONE SR Command Reference Guide*.

The following example pings an IPv6 destination address:

```
device# ping ipv6 2001:db8:60:69bc:92:218:8bff:fe40:1470 vrf mgmt-vrf

ping 2001:db8:60:69bc:92:218:8bff:fe40:1470
PING 2001:db8:60:69bc:92:218:8bff:fe40:1470 (2001:db8:60:69bc:92:218:8bff:fe40:1470) from
2001:db8:60:69bc:92:218:8bff:fe40:1470 default-vrf: 54(82) bytes of data.

--- 2001:db8:60:69bc:92:218:8bff:fe40:1470 ping statistics ---
3 packets transmitted, 3 received, 0% packet loss, time 4192ms
device#
```

IPv6 Traceroute

The **traceroute ipv6** command displays the path of network packets from a Extreme OS ONE device to an IPv6 host. Traceroute is a network diagnostic tool used to track the path that packets take from your device to a destination IP address or hostname. It shows each hop (router or gateway) that the packet goes through to help identify where delays or failures occur in the network.

A traceroute displays information for each hop as soon as the information is received. Optional parameters include the interface name, minimum and maximum Time to Live (TTL) values in a number of hops, source address, time (in seconds) to wait for a response, and VRF instance name.

The device displays up to three responses when there are multiple equal-cost routes to the destination.

For more information about the command, including examples, see the *Extreme OS ONE SR Command Reference Guide*.

The following example executes an IPv6 traceroute with minimum and maximum TTL values, a source IPv6 address, and a timeout value:

```
device# traceroute ipv6 2001:db8:60:69bc:92:218:8bff:fe40:1470
maxttl 128 minttl 30 source 2001:db8:60:69bc:92:205:33ff:fe9e:3f20 timeout 3

traceroute to 2001:db8:60:69bc:92:218:8bff:fe40:1470
(2001:db8:60:69bc:92:218:8bff:fe40:1470),
128 hops max, 80 byte packets
30 2001:db8:60:69bc:92:218:8bff:fe40:1470
(2001:db8:60:69bc:92:218:8bff:fe40:1470) 2.145 ms 2.118 ms 2.085 ms
device#
```

The following example executes an IPv6 traceroute for a VRF named vrf1. The output shows two hops:

```
device# traceroute ipv6 2001:db8::1 vrf vrf1

traceroute to 2001:db8::1 (2001:db8::1), 30 hops max, 80 byte packets
 1 2001:db8:10:1:3::2 (2001:db8:10:1:3::2)  1.117 ms  1.082 ms  1.056 ms
 2 2001:db8::1 (2001:db8::1)  2.103 ms  2.108 ms  2.102 ms
device#
```

IPv6 Neighbor Discovery

The Neighbor Discovery feature for IPv6 uses IPv6 ICMP messages to perform the following tasks:

- Determines the link-layer address of a neighbor on the same link
- Verifies that a neighbor is reachable
- Tracks neighbor routers

An IPv6 host must listen for and recognize the following addresses that identify itself:

- Link local address
- Assigned unicast address
- Loopback address
- All-nodes multicast address
- Solicited node multicast address
- Multicast address to all other groups to which it belongs

IPv6 Neighbor Discovery features that you can adjust include the following:

- Neighbor solicitation messages for duplicate address detection
- Router advertisement messages, which include the following configuration:
 - Interval between router advertisement messages
 - Value that indicates a router is advertised as a default router (for use by all nodes on a link)
 - Prefixes advertised in router advertisement messages
 - Flags for host stateful autoconfiguration



Note

For all solicitation and advertisement messages, Extreme OS ONE uses seconds as the unit of measure instead of milliseconds.



Note

Neighbor Discovery is not supported on tunnel interfaces.

Router Advertisement and Solicitation Messages

Router advertisement and solicitation messages enable a node on a link to discover the routers on the same link.

Each configured router interface on a link sends out a router advertisement message (which has a value of 134 in the Type field of the ICMP packet header) periodically to the all-nodes link local multicast address (FF02::1).

A configured router interface can also send a router advertisement message in response to a router solicitation message from a node on the same link. This message is sent to the unicast IPv6 address of the node that sent the router solicitation message.

At system startup, a host on a link sends a router solicitation message to the all-routers multicast address (FF01). Sending a router solicitation message (which has a value of 133 in the Type field of the ICMP packet header) lets the host automatically configure its IPv6 address immediately instead of awaiting the next periodic router advertisement message.

Because a host at system startup typically does not have a unicast IPv6 address, the source address in the router solicitation message is usually the unspecified IPv6 address (0:0:0:0:0:0:0:0). If the host has a unicast IPv6 address, the source address is the unicast IPv6 address of the host interface sending the router solicitation message.

Configure IPv6 Router Advertisement

You can configure the interval for sending router advertisements, the router advertisement lifetime, the hop limit, and several other settings. As a best practice, ensure that the interval between router advertisement transmission is less than or equal to the router lifetime value if the router is advertised as a default route.

IPv6 router advertisement has the following limitations or unsupported features:

- [RFC 6104 Rogue IPv6 Router Advertisement Problem Statement](#)
- [RFC 6105 IPv6 Router Advertisement Guard](#)
- [RFC 6106 IPv6 Router Advertisement Options for DNS Configuration](#)
- Origination of router solicitation
- IPV4 router advertisement

1. Access global configuration mode.

```
device# configure terminal
```

2. Access interface configuration mode.

```
device# interface ethernet 0/1
```

3. Access IPv6 router advertisement configuration mode.

```
device(config-if-eth-0/1)# ipv6-router-advertisement
```

4. (Optional) Configure the allowed maximum number of hops for the IPv6 router advertisement.

```
device(config-if-eth-0/1-ipv6-router-advertisement)# hop-limit 133
```

The default hop limit is 64 hops.

5. (Optional) Configure the lifetime for the IPv6 router advertisement.

```
device(config-if-eth-0/1-ipv6-router-advertisement)# lifetime 200
```

The default lifetime is 1800 seconds. If you set the lifetime to 0, the router is not advertised as a default router.

6. (Optional) Enable the managed address configuration flag for IPv6 router advertisement.

```
device(config-if-eth-0/1-ipv6-router-advertisement)# managed-config-flag
```

The managed address configuration flag is disabled by default. When this feature is enabled, the managed address configuration (M) flag is set in the router advertisement. This flag indicates that there are addresses available via DHCPv6.

7. (Optional) Disable the transmission of unsolicited messages for IPv6 router advertisement.

```
device(config-if-eth-0/1-ipv6-router-advertisement)# mode disable-unsolicited-ra
```

Transmission of unsolicited router advertisement messages is enabled by default.

8. (Optional) Enable the other configuration (O) flag for IPv6 router advertisement.

```
device(config-if-eth-0/1-ipv6-router-advertisement)# other-config
```

The O flag is disabled by default. When this feature is enabled, the O flag is set in the advertised router advertisement. The O flag indicates that there is other configuration available via DHCPv6 (such as DNS servers).

9. (Optional) Configure the maximum and minimum intervals for IPv6 router advertisement.

```
device(config-if-eth-0/1-ipv6-router-advertisement)# interval 100 min 50
```

These are the intervals during which router advertisement messages are sent randomly.

The maximum interval is 600 seconds by default. The minimum interval is .33 x the maximum interval, if the maximum interval is nine seconds or more, by default (otherwise, the default equals the maximum interval).

10. Enable IPv6 router advertisement on the interface.

```
device(config-if-eth-0/1-ipv6-router-advertisement)# enable
```

11. Configure a prefix for IPv6 router advertisement.

```
device(config-if-eth-0/1-ipv6-router-advertisement)# prefix 2001:db8:100::1/64
device(config-if-ipv6-router-advertisement-prefix-2001:db8:100::1/64)# advertisement
device(config-if-ipv6-router-advertisement-prefix-2001:db8:100::1/64)#
autoconfiguration
device(config-if-ipv6-router-advertisement-prefix-2001:db8:100::1/64)# onlink
device(config-if-ipv6-router-advertisement-prefix-2001:db8:100::1/64)# preferred-
lifetime 5000
device(config-if-ipv6-router-advertisement-prefix-2001:db8:100::1/64)# valid-lifetime
1000
```

Advertisement is enabled by default. This makes the prefix get advertised.

Autoconfiguration is optional and is enabled by default. When autoconfiguration is disabled, the prefix will not be used for stateless address configuration. This is achieved by setting the autonomous address configuration bit for the prefix.

Onlink is optional and is enabled by default. When onlink is enabled, the prefix is marked as being "on link" via the L flag bit for the prefix within a router advertisement. This flag tells hosts that the prefix is reachable directly on the local link. This means that packets to destinations within that prefix will be sent directly (without going through a router).

The default values for preferred lifetime and valid lifetime are 604,800 seconds and 2,592,000 seconds respectively. The preferred lifetime value must not exceed the valid lifetime value. The preferred lifetime is the length of time that the address within the prefix remains in the preferred state, which means that unrestricted use is allowed by upper-layer protocols. The valid lifetime is the length of time that the prefix is valid relative to the time the packet was sent.

The following example displays the configuration of Ethernet interface 0/1 that is running currently on the device. In this example, IPv6 router advertisement is configured on the interface:

```
device# show running-config interface ethernet 0/1

!
interface ethernet 0/1
  ipv6 address 2001:db8:1111::10/64
  ipv6 neighbor 2001:db8:1111::1 00:04:96:eb:c4:51
  ipv6-router-advertisement
    hop-limit 133
    lifetime 200
    managed-config-flag
    mode disable-unsolicited-ra
    other-config
    enable
    interval 100 min 50
    prefix 2001:db8:100::1/63
    prefix 2001:db8:100::1/64
      advertisement
      autoconfiguration
      onlink
      preferred-lifetime 5000
      valid-lifetime 10000
  !
  no shutdown
!
device#
```

The following example displays details about IPv6 router advertisement on Ethernet interface 0/1:

```
device# show ipv6 router-advertisement interface ethernet 0/1

If Name: ethernet 0/1.0
ICMPv6 active timers:
  Last Router-Advertisement sent :0s
  Next Router-Advertisement sent in : 2s
Router-Advertisement parameters:
  Ra Enable flag : true
  Router lifetime field : 1800
```

```
Periodic interval : 20 to 10 seconds
Managed Address Configuration flag : true
Other config flag : true
RA Mode : disable_unsolicited_ra
Current Hop Limit field : 0
MTU option value : 1500
Reachable Time field : 1200
device#
```

Duplicate Address Detection

Although the stateless auto configuration feature assigns the 64-bit interface ID portion of an IPv6 address using the MAC address of the host's NIC, duplicate MAC addresses can occur. Therefore, the duplicate address detection feature verifies that a unicast IPv6 address is unique before it is assigned to a host interface by the stateless auto configuration feature. Duplicate address detection (DAD) verifies that a unicast IPv6 address is unique.

If duplicate address detection identifies a duplicate unicast IPv6 address, the address is not used. If the duplicate address is the link local address of the host interface, the interface stops processing IPv6 packets.

In the DAD NS message, the source address field in the IPv6 header is set to the unspecified address (::). The address being queried for duplication cannot be used until it is determined that there are no duplicates. In the neighbor advertisement (NA) reply to a DAD NS message, the destination address in the IPv6 header is set to the link local all-nodes multicast address (FF02::1). The Solicited flag in the NA message is set to 0. Because the sender of the DAD NS message is not using the desired IP address, it cannot receive unicast NA messages. Therefore, the NA message is multicast.

Upon receipt of the multicast NA message with the target address field set to the IP address for which duplication is being detected, the node disables the use of the duplicate IP address on the interface. If the node does not receive an NA message that defends the use of the address, it initializes the address on the interface.

Configure a Static Neighbor Entry for an Interface

A static entry in the IPv6 Neighbor Discovery (ND) cache ensures that an IPv6 neighbor is always reachable. You can create a static ND entry for a device that is not yet connected to the network or to prevent an entry from aging out. You can configure static ND entries for Ethernet, port channel (LAG), and Virtual Ethernet (VE) interfaces as well as Ethernet and port channel subinterfaces.

1. Access global configuration mode.

```
device# configuration terminal
```

2. Specify the interface to contain the static ND entry.

```
device(config)# interface ethernet 0/1
```

3. Create the static ND entry for the neighbor.

```
device(config-if-eth-0/1)# ipv6 neighbor 2001:db8:2678::2 0000.002b.8641
```

This example adds a static ND entry for a neighbor with IPv6 address 2001:db8:2678::2 and MAC address aa:aa:aa:aa:aa:aa, reachable through physical port ethernet 0/1.

The following example displays the configuration of Ethernet interface 0/1 that is running currently on the device. In this example, the ND IPv6 address and MAC address on the interface are set to 2001:db8:2678::2 and aa:aa:aa:aa:aa:aa respectively:

```
device# show running-config interface ethernet 0/1

interface ethernet 0/1
  ipv6 address 2001:DB8:1::1
  ipv6 neighbor 2001:db8:2678::2 aa:aa:aa:aa:aa:aa
  no shutdown
!
device#
```

The following examples show how to configure static ND entries for Ethernet, port channel (LAG), and Virtual Ethernet (VE) interfaces as well as Ethernet and port channel subinterfaces respectively:

```
device# configure terminal
device(config)# interface ethernet 0/1
device(config-if-eth-0/1)# ipv6 neighbor 2001:db8:2678::2 aa:aa:aa:aa:aa:aa
device(config-if-eth-0/1)#

device# configure terminal
device(config)# interface port-channel 10
device(config-if-po-10)# ipv6 neighbor 2001:db8:2678::3 aa:aa:aa:aa:aa:ab
device(config-if-po-10)#

device# configure terminal
device(config)# interface ve 100
device(config-if-ve-100)# ipv6 neighbor 2001:db8:2678::4 aa:aa:aa:aa:aa:ac
device(config-if-ve-100)#

device# configure terminal
device(config)# interface ethernet 0/1
device(config-if-eth-0/1)# subinterface vlan 100
device(config-subif-eth-0/1.100)# ipv6 neighbor 2001:db8:2678::5 aa:aa:aa:aa:aa:ad
device(config-subif-eth-0/1.100)#

device# configure terminal
device(config)# interface port-channel 10
device(config-if-po-10)# subinterface vlan 200
device(config-subif-po-10.200)# ipv6 neighbor 2001:db8:2678::6 aa:aa:aa:aa:aa:ae
device(config-subif-po-10.200)#
```

Configure Reachable Time for Remote IPv6 Nodes

You can configure the duration (in seconds) that a router considers a remote IPv6 node to be reachable. You can configure neighbor discovery (ND) reachable time for Ethernet, port channel (LAG), and Virtual Ethernet (VE) interfaces as well as Ethernet and port channel subinterfaces.

To do so, you use the **ipv6 neighbor reachable-time** command to configure the ND IPv6 neighbor reachable-time configuration on an interface. ND establishes

correspondences between pairs of network-layer (Layer 3) addresses and LAN hardware addresses (Layer 2 MAC addresses).

Router advertisement messages include a *reachable time* value. All nodes on a link use the same value.

Reachable time is how long a device considers another device to be reachable after successfully contacting it without re-verifying its presence. When a device sends traffic to a neighbor and receives a response, it marks that neighbor as reachable.

The reachable time is a timer that specifies how long the entry stays in the reachable state before the device must probe or refresh the neighbor information. If no additional communication happens during the reachable time, the device transitions the neighbor entry to a stale state and eventually needs to verify it again using an ND request.

You should configure a long duration, because a short duration causes IPv6 network devices to process the information at a greater frequency.

1. Access global configuration mode.

```
device# configuration terminal
```

2. Access interface configuration mode.

```
device(config)# interface ethernet 0/1
```

3. Configure the reachable time.



Note

The actual reachable time ranges from 0.5 to 1.5 times the configured or default value.

```
device(config-int-eth-0/1)# ipv6 neighbor reachable-time 300
```

The range is 30 to 3600 seconds. The default is 1200 seconds.

The following examples show how to configure IPv6 neighbor reachable time on Ethernet, port channel (LAG), and Virtual Ethernet (VE) interfaces as well as on Ethernet and port channel subinterfaces respectively:

```
device# configure terminal
device(config)# interface ethernet 0/1
device(config-if-eth-0/1)# ipv6 neighbor reachable-time 300
device(config-if-eth-0/1)#

device# configure terminal
device(config)# interface port-channel 10
device(config-if-po-10)# ipv6 neighbor reachable-time 600
device(config-if-po-10)#

device# configure terminal
device(config)# interface ve 100
device(config-if-ve-100)# ipv6 neighbor reachable-time 1500
device(config-if-ve-100)#

device# configure terminal
device(config)# interface ethernet 0/1
device(config-if-eth-0/1)# subinterface vlan 100
device(config-subif-eth-0/1.100)# ipv6 neighbor reachable-time 2500
device(config-subif-eth-0/1.100)#

device# configure terminal
device(config)# interface port-channel 10
```

```

device(config-if-po-10)# subinterface vlan 200
device(config-subif-po-10.200)# ipv6 neighbor reachable-time 3600
device(config-subif-po-10.200)#

```

The following example displays the configuration of Ethernet interface 0/1 that is running currently on the device. In this example, the IPv6 neighbor reachable time is set to 300 seconds on the interface:

```

device# show running-config interface ethernet 0/1

interface ethernet 0/1
  mtu 1600
  ipv6 neighbor reachable-time 300
  no shutdown
!
device#

```

IPv6 ICMP Rate Limiting on the Management Interface

IPv6 Internet Control Message Protocol (ICMP) rate limiting lets you control and monitor IPv6 ICMP echo-request (ping) traffic on the management interface. This protects the interface from ping flooding attacks and excessive IPv6 ICMP traffic that could impact device performance.

This feature ensures device manageability by allowing necessary diagnostics while dropping excessive traffic. It specifically throttles IPv6 ICMP traffic to allow safe troubleshooting without affecting management traffic such as SSH or HTTPS.

ICMP rate limiting on the management interface in IPv6 functions the same as it does in IPv4. For details about configuring and monitoring IPv6 ICMP rate limiting on the management interface, see the *Extreme OS ONE SR Security Configuration Guide*.

Display Global IPv6 Information

You can use **show** commands to display information about IPv6 interfaces, neighbors, and route tables.

1. Display IPv6 interface information.

```

device# show ipv6 interface brief

```

L3 Interface status	IPv6-Address	Vrf	Admin status	Oper status	Address
Eth 0/9:3.1332	2001:db8:535::2	default-vrf	UP	UP	PREFERRED
Eth 0/9:3.2399	2001:db8:960::2	default-vrf	UP	UP	PREFERRED
Eth 0/9:3.3054	2001:db8:bef::2	default-vrf	UP	UP	PREFERRED
Eth 0/9:3.3254	2001:db8:cb7::2	default-vrf	UP	UP	PREFERRED
Eth 0/9:3.523	2001:db8:20c::2	default-vrf	UP	UP	PREFERRED
Eth 0/9:3.2044	2001:db8:7fd::2	default-vrf	UP	UP	PREFERRED
Eth 0/9:3.2563	2001:db8:a04::2	default-vrf	UP	UP	PREFERRED
Eth 0/9:3.520	2001:db8:209::2	default-vrf	UP	UP	PREFERRED
Eth 0/9:3.2109	2001:db8:83e::2	default-vrf	UP	UP	PREFERRED
Eth 0/9:3.3328	2001:db8:d01::2	default-vrf	UP	UP	PREFERRED
Eth 0/9:3.3798	2001:db8:ed7::2	default-vrf	UP	UP	PREFERRED
Eth 0/9:3.2148	2001:db8:865::2	default-vrf	UP	UP	PREFERRED
Eth 0/9:3.312	2001:db8:139::2	default-vrf	UP	UP	PREFERRED

```

Eth 0/9:3.695      2001:db8:2b8::2    default-vrf    UP            UP            PREFERRED
Eth 0/9:3.720      2001:db8:2d1::2    default-vrf    UP            UP            PREFERRED
Eth 0/9:3.760      2001:db8:2f9::2    default-vrf    UP            UP            PREFERRED
Eth 0/9:3.1166     2001:db8:48f::2    default-vrf    UP            UP            PREFERRED
Eth 0/9:3.1641     2001:db8:66a::2    default-vrf    UP            UP            PREFERRED
Eth 0/9:3.2086     2001:db8:827::2    default-vrf    UP            UP            PREFERRED
device#

```

2. Display IPv6 neighbor information for an interface.

```

device# show ipv6 neighbor interface ve 822

-----
Interface Name:  _bridge_domain 822

IP Address          MAC Address          Type          Interface  L2
Interface          Age
=====
=====

2001:db8:337::1    00:04:96:eb:c4:51   Local        ve 822     -
2h17m3s

2001:db8:337::10  00:10:94:00:07:1d   Dynamic      ve 822     port-channel 1.822
15m19s

2001:db8:337::40  00:10:94:00:46:b3   MLAG         ve 822     port-channel 1.822
2h7m1s

2001:db8:337::60  00:10:94:00:56:b1   MLAG         ve 822     port-channel 1.822
2h6m45s

2001:db8:337::90  00:10:94:00:66:af   MLAG         ve 822     port-channel 1.822
1h22m9s

fe80::204:96ff:feeb:c451  00:04:96:eb:c4:51   Local        ve 822     -
2h17m3s
device#

```

3. Display the IPv6 neighbor discovery protocol (NDP) entries in the neighbor caches.

```

device# show ipv6 neighbor vrf default-vrf

vrf :default-vrf
-----
Total number of neighbor entries: 4

Ipv6 address      Mac-address          Type          Interface      L2 Interface
Age
=====
=====

2001:db8:1111::1  aa:aa:aa:aa:aa:aa   Dynamic      ethernet 0/1:1  ethernet 0/1:1
17m35s

2001:db8:1112::2  bb:bb:bb:bb:bb:bb   Static       ethernet 0/1:1  ethernet 0/1:1
17m37s

2001:db8:1113::3  cc:cc:cc:cc:cc:cc   Dynamic      ethernet 0/1:3  ethernet 0/1:3
17m40s

2001:db8:1114::4  dd:dd:dd:dd:dd:dd   Static       ve 100          ethernet 0/1:4
17m42s
device#

```

4. Display the IPv6 route table.

```

device# show ipv6 route vrf default-vrf

Resilient Hash: Disabled

```

```

Ecmp Max Path: 128
Total number of IPv6 routes: 26, Max Routes: Not Set
'[x/y]' denotes [preference/metric]
2001:db8:1001::/64, attached, [0/0], tag 0, 1m12s
  via direct, ethernet 0/1:1
2001:db8:1001::1/128, local, [0/0], tag 0, 1m12s
  via direct, ethernet 0/1:1
2001:db8:2001::/64, attached, [0/0], tag 0, 1m4s
  via direct, ethernet 0/1:2.200
2001:db8:2001::1/128, local, [0/0], tag 0, 1m4s
  via direct, ethernet 0/1:2.200
2001:db8:3001::/64, attached, [0/0], tag 0, 17s
  via direct, ve 100
2001:db8:3001::1/128, local, [0/0], tag 0, 17s
device#

```

5. Display the aggregated numbers of IPv6 ICMP packets that were filtered because of ICMP rate limiting on the management interface.

```

device# show counters icmp interface management 0

ICMP Packet Summary:
  ICMPv4 Accepted Packets: 8
  ICMPv4 Dropped Packets: 11
  ICMPv6 Accepted Packets: 0
  ICMPv6 Dropped Packets: 0
device#

```

In this release, the only supported management interface name is 0. For details about configuring and monitoring IPv6 ICMP rate limiting on the management interface, see the *Extreme OS ONE SR Security Configuration Guide*.

Clear Global IPv6 Information

You can use **clear** commands to remove IPv6 neighbor discovery information and IPv6 routes.

1. Clear the IPv6 neighbor discovery cache on an interface.

```
device# clear ipv6 neighbor interface ethernet 0/1
```

2. Clear the IPv6 neighbor discovery cache on a VRF.

```
device# clear ipv6 neighbor vrf default-vrf
```

3. Clear the IPv6 routing tables on a VRF.

```
device# clear ipv6 route vrf default-vrf
```

4. Clear statistics for the management interface. This includes the aggregated numbers of IPv6 ICMP packets that the system accepted or dropped because of ICMP rate limiting.

```
device# clear counters interface management 0
device#
```

In this release, the only supported management interface name is 0. For details about configuring and monitoring IPv6 ICMP rate limiting on the management interface, see the *Extreme OS ONE SR Security Configuration Guide*.

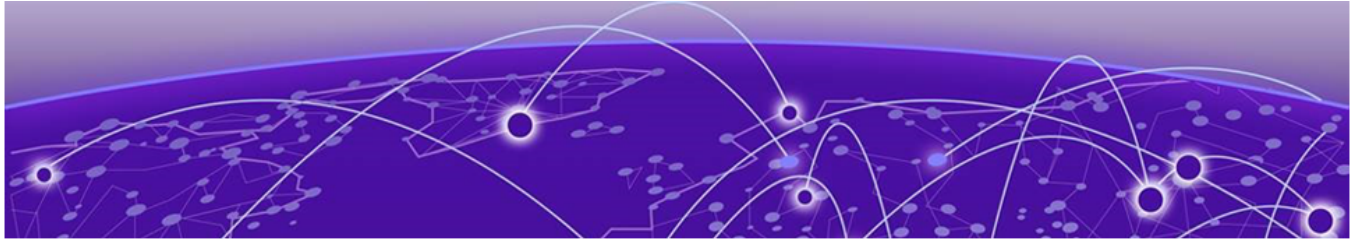

IPv4 Static Routing

- [IPv4 Static Routing](#) on page 53
- [IPv4 Static Route Availability](#) on page 54
- [Default VRF and User-Defined VRFs](#) on page 55
- [BFD for Layer 3 Protocols](#) on page 56
- [Configure a Basic IPv4 Static Route](#) on page 57
- [Configure an IPv4 Static Route with an Interface Next Hop](#) on page 57
- [Configure a BFD session for an IPv4 static route](#) on page 58
- [Disable Recursive Lookup for an IPv4 Static Route](#) on page 59
- [Add a Cost Metric or Administrative Distance to an IPv4 Static Route](#) on page 60
- [Configure an IPv4 Static Route to Use with a Route Map](#) on page 60
- [Configure an IPv4 Null Static Route](#) on page 61
- [Configure a Default IPv4 Static Route](#) on page 62
- [Configure IPv4 Static Routes for Load Sharing and Redundancy](#) on page 62
- [Remove an IPv4 Static Route](#) on page 64
- [Display IPv4 Static Route Information](#) on page 65

The following topics describe how to configure IPv4 static routing.

IPv4 Static Routing

Static routes can be used to specify desired routes, backup routes, or routes of last resort. Static routing can help provide load balancing .

The IPv4 route table can receive routes from several sources, such as static routes, directly connected networks, and BGP4.

Static routes are manually configured entries in the IPv4 routing table. Next hop functionality supports IP addresses and interfaces such as Ethernet, Port Channel (PO), or Virtual Ethernet (VE) interfaces.

You can influence the preference that a route is given by configuring it as follows:

- Configuring a route metric higher than the default metric.
- Giving the route an administrative distance.
- Specifying a route tag for use with a route map.

Static routes can be configured to serve as any of the following route types:

- Default routes
- Primary routes
- Backup routes
- Null routes (for dropping traffic intentionally when the desired connection fails)
- Alternate routes to the same destination (to help load balance traffic)

IPv4 Static Route Availability

IPv4 static routes remain in the IP route table only as long as the port or virtual interface used by the route is available and the next hop IP address is valid.

If the interface is not available and the next hop IP address is invalid, the software removes the static route from the route table. When the port or VE interface becomes available and the next hop is valid, the software adds the route to the route table.

You use this feature to configure the router to adjust to changes in network topology. The router does not continue trying to use routes on unavailable paths. Instead, it uses routes only when their paths are available.

Figure 2 shows an example of a static route that is configured on Switch A:

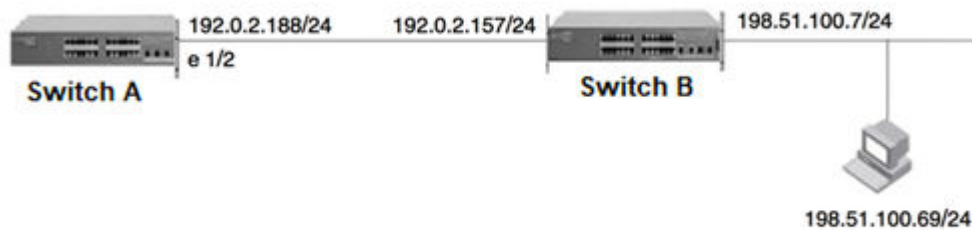

Figure 2: Example of an IPv4 static route

In Figure 2, the static route to the 192.0.2.188 destination is configured as follows. 192.0.2.157 is used as the next hop gateway:

```
device(config-vrf-default-vrf)# static-route 192.0.2.188/24 192.0.2.157
device(config-vrf-default-vrf)#
```

When you configure a static IP route, you specify the destination address for the route and the next hop gateway or Layer 3 interface through which the Layer 3 device can reach the route. The device adds the route to the IP route table. In this case, Switch A knows that 192.0.2.157 is reachable through port 1/2 and also assumes that local interfaces in that subnet are on the same port. Switch A deduces that IP interface 198.51.100.69 is also on port 1/2.

Default VRF and User-Defined VRFs

You can use two types of VRF: the default VRF and user-defined VRFs.

Default VRF: The default VRF (always named `default-vrf` in the system) is used for general routing and is the primary VRF for most network traffic. It exists automatically on the device without any specific configuration. It acts as the device's global routing table. Interfaces are not assigned to the default VRF and must be explicitly moved to a user-defined VRF. Routes and interfaces in the default VRF are separate from those in user-defined VRFs, which prevents route leakage unless explicitly configured otherwise.

User-Defined VRFs: You create user-defined VRFs to isolate specific network traffic or services. Each VRF has an independent routing table and forwarding rules and is used to segregate and manage traffic for different departments, customers, or services in the same physical network infrastructure. They offer granular control over routing policies, interfaces, and security. They also offer flexibility and isolation for specialized network configurations when you use them for the following purposes:

- Creating virtual networks to separate tenants or virtual networks on the same physical infrastructure.
- Isolating services or applications (for example, web servers and database servers) onto their VRFs.
- Providing a sandboxed environment for testing and development.

The VRF handles general network operations, while user-defined VRFs provide customized isolation and routing for specific needs.

Following is an example of the default VRF after configuration:

```
device# show running-config vrf default-vrf

member loopback 1-2
static-route 203.0.113.0/24 192.0.2.1 enable-bfd profile default
static-route 203.0.113.0/24 192.0.2.1 enable-bfd profile default
static-route 203.0.113.0/24 192.0.2.1 enable-bfd profile default
static-route 203.0.113.0/24 192.0.2.1 enable-bfd profile default
static-route 198.51.100.0/24 192.0.2.1 enable-bfd profile default
static-route 198.51.100.0/24 192.0.2.1 enable-bfd profile default
static-route 198.51.100.0/24 192.0.2.1 enable-bfd profile default
static-route 192.0.2.0/24 192.0.2.1 enable-bfd profile default
device#
```

Following is an example of a user-defined VRF named `uservrf1` after configuration:

```
device# show running-config vrf uservrf1

member ethernet 0/1:1
member ethernet 0/1:2
member ethernet 0/1:3
member ethernet 0/1:4
member port-channel 1 vlan 1-60
member port-channel 2 vlan 61-120
member port-channel 3 vlan 121-180
member port-channel 4 vlan 181-240
static-route 203.0.113.0/24 192.0.2.1 enable-bfd profile default
static-route 203.0.113.0/24 192.0.2.1 enable-bfd profile default
static-route 203.0.113.0/24 192.0.2.1 enable-bfd profile default
```

```

static-route 203.0.113.0/24 192.0.2.1 enable-bfd profile default
static-route 203.0.113.0/24 198.51.100.1 enable-bfd profile default
static-route 203.0.113.0/24 198.51.100.1 enable-bfd profile default
static-route 198.51.100.0/24 192.0.2.1 enable-bfd profile default
static-route 198.51.100.0/24 192.0.2.1 enable-bfd profile default
static-route 192.0.2.0/24 192.0.2.1 enable-bfd profile default
static-route 203.0.113.0/24 192.0.2.1 enable-bfd profile default
static-route 2001:db8:2003:1::/64 2001:db8:1004:1::1 enable-bfd profile default
static-route 2001:db8:2003:13:1::/64 2001:db8:1004:13:1::1 enable-bfd profile default
static-route 2001:db8:2000::/64 2001:db8:1001:23:1::1 enable-bfd profile default
static-route 2001:db8:2002::/64 2001:db8:1003:21:1::1 enable-bfd profile default
static-route 2001:db8:2001::/64 2001:db8:1002:26:1::1 enable-bfd profile default
static-route 2001:db8:2002::/64 2001:db8:1003:2d:1::1 enable-bfd profile default
static-route 2001:db8:2003:1f:1::/64 2001:db8:1004:1f:1::1 enable-bfd profile default
static-route 2001:db8:2002::/64 2001:db8:1003:12:1::1 enable-bfd profile default
static-route 2001:db8:2002::/64 2001:db8:1003:39:1::1 enable-bfd profile default
static-route 2001:db8:2003:33:1::/64 2001:db8:1004:33:1::1 enable-bfd profile default
static-route 2001:db8:2003:38:1::/64 2001:db8:1004:38:1::1 enable-bfd profile default
static-route 2001:db8:2003:32:0/64 2001:db8:1004:33:1::1 enable-bfd profile default
static-route 2001:db8:2000:a:1::/64 2001:db8:1001:a:1::1 enable-bfd profile default
static-route 2001:db8:2000:b:1::/64 2001:db8:1001:b:1::1 enable-bfd profile default
static-route 2001:db8:2003:a:1::/64 2001:db8:1004:a:1::1 enable-bfd profile default
static-route 198.51.100.0/24 192.0.2.1 enable-bfd profile default
static-route 203.0.113.0/24 192.0.2.1 enable-bfd profile default
static-route 198.51.100.0/24 192.0.2.1 enable-bfd profile default
static-route 198.51.100.0/24 192.0.2.1 enable-bfd profile default
static-route 203.0.113.0/24 192.0.2.1 enable-bfd profile default
static-route 198.51.100.0/24 192.0.2.1 enable-bfd profile default
device#

```

BFD for Layer 3 Protocols

Layer 3 protocols can use Bidirectional Forwarding Detection (BFD) for rapid failure detection in the forwarding path between two adjacent routers, including the interfaces, data links, and forwarding planes.

BFD can be configured for use with the following protocols:

- BGP4
- BGP4+
- Static Route

BFD must be enabled at the interface and routing protocol levels. BFD asynchronous mode depends on the sending of BFD control packets between two systems to activate and maintain BFD neighbor sessions between routers. Therefore, BFD must be configured on both BFD peers.

A BFD session is created after BFD is enabled on the interfaces and at the router level for the appropriate routing protocols. BFD timers are then negotiated, and the BFD peers begin to send BFD control packets to each other at the negotiated interval.

BFD provides one point of forwarding path monitoring when more than one Layer 3 application wants to monitor a host. BFD runs a session for that host and provides the status to multiple applications, instead of multiple applications running individual sessions to the host.

By sending rapid failure detection notices to the routing protocols in the local device to initiate the routing table recalculation process, BFD contributes to greatly reducing overall network convergence time.

Configure a Basic IPv4 Static Route

To configure a basic IPv4 static route, you specify the IPv4 destination address, the address mask, and the IPv4 address of the next hop.

1. Access global configuration mode.

```
device# configure terminal
```

2. Specify a VRF name and enter VRF configuration mode.

```
device(config)# vrf default-vrf
```

3. Enter the IP address and prefix length for the route destination network and the IP address for the next hop.



Note

Prefix lengths must be used as part of the address. Network masks cannot be used. The prefix length of /8 is equivalent to a network mask of 255.0.0.0. The prefix length of /24 (equivalent to the mask 255.255.255.0) matches all hosts in the Class C subnet address in the destination IP address.

```
device(config-vrf-default-vrf)# static-route 192.0.2.0/24 192.0.2.1
```

Configure an IPv4 Static Route with an Interface Next Hop

To configure an IPv4 static route that uses an interface as a next hop, you specify the IPv4 destination address, the address mask, and the interface of the next hop.

1. Access global configuration mode.

```
device# configure terminal
```

2. Specify a VRF name and enter VRF configuration mode.

```
device(config)# vrf default-vrf
```

3. Enter the IP address and prefix length for the route destination network and the interface for the next hop.



Note

Prefix lengths must be used as part of the address. Network masks cannot be used. The prefix length of /8 is equivalent to a network mask of 255.0.0.0. The prefix length of /24 (equivalent to the mask 255.255.255.0) matches all hosts in the Class C subnet address in the destination IP address.

```
device(config-vrf-default-vrf)# static-route 192.0.2.0/24 interface ethernet 0/1
device(config-vrf-default-vrf)# static-route 192.0.2.1/24 interface port-channel 25
device(config-vrf-default-vrf)# static-route 192.0.2.2/24 interface ve 1
```

Configure a BFD session for an IPv4 static route

An IPv4 static route is associated with a static Bidirectional Forwarding Detection (BFD) session when the next hop for the static route matches the neighbor address of the static BFD neighbor, and BFD monitoring is enabled for the static route.

When static BFD is configured, the static route manager checks the routing table for a route to the BFD neighbor. If a route exists and the next hop is directly connected, a single-hop session is created. If the next hop is not directly connected, a multihop BFD session is created.

When the BFD session is up, a corresponding static route is added to the routing table. When the BFD session that monitors the static route goes down because the BFD neighbor is not reachable, static routes are removed from the routing table. The device replaces these removed routes in the routing table when the BFD neighbor is reachable.

To use BFD for an IPv4 static route, you configure the static route and the corresponding static BFD separately.

1. Access global configuration mode.

```
device# configure terminal
```

2. Access BFD configuration mode.

```
device(config)# bfd
```

3. Create a BFD profile.

A BFD profile contains the BFD settings that are applied (or requested to be applied) to a routing protocol that is configured (registered) as a BGP client (meaning that it uses BFD for link failure detection instead of its own mechanism).



Note

If no BFD profile is configured for a static route, the profile configured for the BFD member interface is used. If BFD profiles are configured for both the static route and the member interface, the one with the shorter detection time takes precedence.

```
device(config-bfd)# profile profile1

device(config-bfd)# member
  ethernet      Ethernet
  loopback      Interface Loopback Port
  port-channel  Port-channel
  ve            Ve
device(config-bfd)# member ethernet 0/1
  profile      Add default profile for sessions under this interface
  shutdown     Administratively shutdown the BFD session
device(config-bfd)#
```

4. Configure the interval (the desired rate at which to send BFD control packets to the neighboring system).

This includes the desired minimum transmit interval, minimum receive interval for BFD control packets at the local end point, and a multiplier value that helps to calculate the detection timeout of BFD sessions.

```
device(config-bfd-profile-profile1)# interval 5000 min-rx 10000 multiplier 4
```

- Return to global configuration mode.

```
device(config-bfd-profile-profile1)# exit
device(config-bfd)# exit
```

- Specify a VRF name and enter VRF configuration mode.

```
device(config)# vrf default-vrf
```

- Enter the IP address, prefix length for the route destination network, the IP address for the next hop, and the BFD profile.



Note

Prefix lengths must be used as part of the address. Network masks cannot be used. The prefix length of /8 is equivalent to a network mask of 255.0.0.0. The prefix length of /24 (equivalent to the mask 255.255.255.0) matches all hosts in the Class C subnet address in the destination IP address.

```
device(config-vrf-default-vrf)# static-route 192.0.2.0/24 192.0.2.1 enable-bfd profile
profile1
```

The following is a configuration example for the **bfd-source-interface** option, which is used for multihop BFD:

```
device(config-vrf-default-vrf)# static-route 198.51.100.0/24 192.0.2.1 enable-bfd bfd-
source-interface loopback 1 profile default
device(config-vrf-default-vrf)#
```

Disable Recursive Lookup for an IPv4 Static Route

A device uses recursive lookup to search for another route if the original next hop is not reachable. This feature is enabled by default.

If the next hop for a basic static route is directly reachable, it is added to the routing table. If that next hop is not reachable, the device can perform a lookup for another route (a recursive route). You can disable the recursive lookup feature in the default VRF or in a non-default VRF.



Note

An original next hop is not considered resolved if it is reachable through a default route such as 0.0.0.0/0.

- Access global configuration mode.

```
device# configure terminal
```

- Specify a VRF name and enter VRF configuration mode.

```
device(config)# vrf red
```

- To disable recursive lookup, enter the following command.

```
device(config-vrf-red)# static-route 192.0.2.0/24 192.0.2.1 no-recurse
```

This example disables recursive lookup in a VRF named red.

Add a Cost Metric or Administrative Distance to an IPv4 Static Route

You can influence route preference by adding a cost metric or an administrative distance to a static route.

The device replaces a static route if it receives a route to the same destination with a lower administrative distance.

1. Access global configuration mode.

```
device# configure terminal
```

2. Specify a VRF name and enter VRF configuration mode.

```
device(config)# vrf default-vrf
```

3. Designate the route destination, the next hop, and the route priority.

Option	Description
Cost metric	The value is compared to the metric for other static routes in the IPv4 route table to the same destination. Two or more routes to the same destination with the same metric load will share traffic to the destination. The value can be from 1 through 16. The default is 1. A route with a cost of 16 is considered unreachable.
Administrative distance	This value is compared to the administrative distance of all routes to the same destination. By default, static routes take precedence over learned protocol routes. However, to give a static route a lower priority than a dynamic route, give the static route the higher administrative distance. The value is preceded by the keyword <code>distance</code> and can be from 1 to 254. The default is 1. A value of 255 is considered unreachable.

The following example configures a static route with an administrative distance of 10:

```
device(config-vrf-default-vrf)# static-route 198.51.100.0/24 198.51.100.1 admin-  
distance 10  
device(config-vrf-default-vrf)#
```

The following example configures a static route with an administrative distance of 3:

```
device(config-vrf-default-vrf)# static-route 192.0.2.0/24 192.0.2.1 admin-distance 3  
device(config-vrf-default-vrf)#
```

The following example configures a static route with a cost metric of 2:

```
device(config-vrf-default-vrf)# static-route 192.0.2.0/24 192.0.2.1 metric 2  
device(config-vrf-default-vrf)#
```

Configure an IPv4 Static Route to Use with a Route Map

You can configure a static route with a tag that can be referenced in a route map.

1. Access global configuration mode.

```
device# configure terminal
```

2. Specify a VRF name and enter VRF configuration mode.

```
device(config)# vrf default-vrf
```

3. Enter the destination network IP address and prefix length, the `set-tag` keyword, a tag number, and the next hop IP address.

```
device(config-vrf-default-vrf)# static-route 198.51.100.0/24 set-tag 9999 192.0.2.1
```

The tag "9999" in this example can be used in a route map.

Configure an IPv4 Null Static Route

You can configure a null static route to drop packets to a certain destination. This is useful when the traffic should not be forwarded if the preferred route is unavailable.



Note

You cannot add a null or interface based static route to a network if a static route of any type exists with the same metric you specify for the null or interface based route.

Figure 3 depicts how a null static route works with a standard route to the same destination.

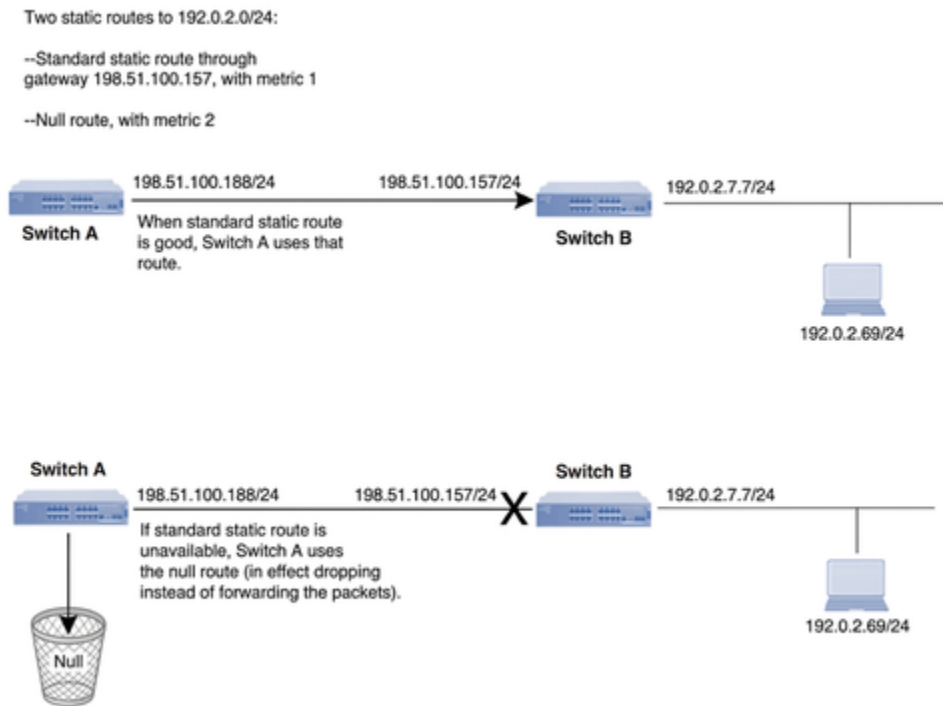

Figure 3: Null route and standard route to same destination

To configure a null static route, complete the following steps.

1. Access global configuration mode.

```
device# configure terminal
```

2. Specify a VRF name and enter VRF configuration mode.

```
device(config)# vrf default-vrf
```

3. Configure the preferred route to a destination.

```
device(config-vrf-default-vrf)# static-route 192.0.2.0/24 192.0.2.1
```

This example creates a static route to destination network addresses that have an IP address beginning with 192.168.7.0. These destinations are routed through the next-hop gateway 192.168.6.157. The route carries the default metric of 1.

4. Configure the null route to the same destination, followed by the keyword null, a space, and a zero. Also specify a metric value of 2 (which is higher than the default metric of 1 as described previously).

```
device(config-vrf-default-vrf)# static-route 192.0.2.0/24 null 0 metric 2
```

This example creates a null static route to the same destination. The metric is set higher so that the preferred route is used if it is available. When the preferred route becomes unavailable, the null route is used, and traffic to the destination is dropped.

The following example summarizes the commands in this procedure:

```
device# configure terminal
device(config)# vrf default-vrf
device(config-vrf-default-vrf)# static-route 192.0.2.0/24 192.0.2.1
device(config-vrf-default-vrf)# static-route 192.0.2.0/24 null 0 metric 2
device(config-vrf-default-vrf)#
```

Configure a Default IPv4 Static Route

A router uses a default static route when there are no other default routes to a destination.

You cannot create a default route to a Virtual Ethernet (VE) or physical interface.

1. Access global configuration mode.

```
device# configure terminal
```

2. Specify a VRF name and enter VRF configuration mode.

```
device(config)# vrf default-vrf
```

3. Enter the destination route and prefix length (0.0.0.0/0) followed by a valid next hop IP address.

```
device(config-vrf-default-vrf)# static-route 0.0.0.0/0 192.0.2.1
```

The following example configures a default route that is a null route:

```
device# configure terminal
device(config)# vrf default-vrf
device(config-vrf-default-vrf)# static-route 0.0.0.0/0 null 0
device(config-vrf-default-vrf)#
```

Configure IPv4 Static Routes for Load Sharing and Redundancy

You can configure multiple static routes to the same destination as load sharing or backup routes.

If you configure more than one static route to the same destination with different next hop gateways but the same metrics, the device load balances among the routes by using a basic round robin method.

If you configure multiple static IP routes to the same destination with different next hop gateways and different metrics, the device uses the route with the lowest metric. If this route becomes unavailable, the device fails over to the static route with the next lowest metric.

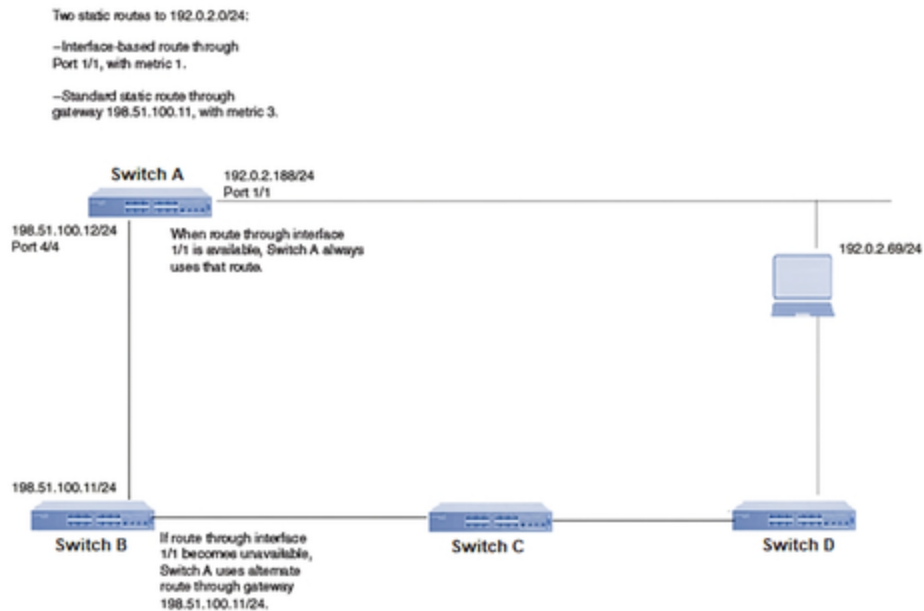

Figure 4: Two static routes to the same destination



Note

You can also use administrative distance to set route priority. Assign the static route a lower administrative distance than other types of routes, unless you want the other route types to be preferred over the static route.

1. Access global configuration mode.

```
device# configure terminal
```

2. Specify a VRF name and enter VRF configuration mode.

```
device(config)# vrf default-vrf
```

3. Enter multiple routes to the same destination using different next hops.

```
device(config-vrf-default-vrf)# static-route 198.51.100.0/24 192.0.2.1
device(config-vrf-default-vrf)# static-route 198.51.100.0/24 192.0.2.2
device(config-vrf-default-vrf)# static-route 198.51.100.0/24 192.0.2.3
```

This example creates three next hop gateways to the destination. Traffic alternates among the three paths through next-hop 192.0.2.1, next hop 192.0.2.2, and next hop 192.0.2.3.

4. To prioritize the routes, use different metrics for each possible next hop.

```
device(config-vrf-default-vrf)# static-route 198.51.100.0/24 192.0.2.1
device(config-vrf-default-vrf)# static-route 198.51.100.0/24 192.0.2.2 metric 2
device(config-vrf-default-vrf)# static-route 198.51.100.0/24 192.0.2.3 metric 3
```

This example creates three alternate routes to the destination. The primary next hop is 192.0.2.1, which has the default metric of 1 (the default metric is not entered in the CLI). If this path is not available, traffic is directed to 192.0.2.2, which has the next lowest metric of 2. If the second path fails, traffic is directed to 192.0.2.3, which has a metric of 3.

Remove an IPv4 Static Route

Use the `no` form of the **static-route** command to remove an IPv4 static route.

1. (Optional) View configured routes and confirm parameters.

```
device# show ipv4 route vrf default-vrf

Resilient Hash: Enabled
Ecmp Max Path: 128
Total number of IPv4 routes: 13, Max Routes: Not Set
'[x/y]' denotes [preference/metric]
192.0.2.0/24, attached, [0/0], tag 0, 5m58s
  via direct, ethernet 0/11:1
192.0.2.1/32, , [0/0], tag 0, 5m58s
  via direct, ethernet 0/11:1
192.0.2.2/32, ARP, [3/0], tag 0, 5m58s
  via , ethernet 0/11:1, [00:16:3e:58:fb:20, ethernet 0/11:1.0]
198.51.100.0/24, attached, [0/0], tag 0, 5m58s
  via direct, ethernet 0/11:2
198.51.100.1/32, , [0/0], tag 0, 5m58s
  via direct, ethernet 0/11:2
198.51.100.2/32, static, [1/1], tag 0, 2m34s
  via 192.0.2.254, ethernet 0/13, [e4:db:ae:5c:24:16, ethernet 0/13]
203.0.113.0/24, attached, [0/0], tag 0, 5m58s
  via direct, ethernet 0/11:3
203.0.113.1/32, , [0/0], tag 0, 5m58s
  via direct, ethernet 0/11:3
203.0.113.3/32, static, [1/1], tag 0, 2m34s
  via 192.0.2.254, ethernet 0/13, [e4:db:ae:5c:24:16, ethernet 0/13]
203.0.113.10/32, ebgp, [20/0], tag 0, 5m32s
  via 192.0.2.2, ethernet 0/11:1, [00:16:3e:58:fb:20, ethernet 0/11:1]
  via 198.51.100.2, ethernet 0/11:2, [00:16:3e:58:fb:21, ethernet 0/11:2]
  via 203.0.113.2, ethernet 0/11:3, [00:16:3e:58:fb:22, ethernet 0/11:3]
198.51.100.20/24, attached, [0/0], tag 0, 5m57s
  via direct, ethernet 0/32:1
198.51.100.20/32, , [0/0], tag 0, 5m57s
  via direct, ethernet 0/32:1
203.0.113.30/24, , [1/1], tag 0, 5m58s
  via 192.0.2.2, ethernet 0/11:1, [00:16:3e:58:fb:20, ethernet 0/11:1]
  via 198.51.100.2, ethernet 0/11:2, [00:16:3e:58:fb:21, ethernet 0/11:2]
  via 203.0.113.2, ethernet 0/11:3, [00:16:3e:58:fb:22, ethernet 0/11:3]
device#
```

2. (Optional) Narrow the output to static routes only.

```
device# show ipv4 route vrf default-vrf static

Resilient Hash: Enabled
Ecmp Max Path: 128
Total number of IPv4 routes: 8, Max Routes: Not Set
'[x/y]' denotes [preference/metric]
198.51.100.2/32, static, [1/1], tag 0, 2m34s
  via 192.0.2.254, ethernet 0/13, [e4:db:ae:5c:24:16, ethernet 0/13]
203.0.113.3/32, static, [1/1], tag 0, 2m34s
  via 192.0.2.254, ethernet 0/13, [e4:db:ae:5c:24:16, ethernet 0/13]
device#
```

3. Access global configuration mode.

```
device# configure terminal
```

4. Specify a VRF name and enter VRF configuration mode.

```
device(config)# vrf default-vrf
```

- Remove the static route, including the destination and next hop.

```
device(config-vrf-default-vrf)# no static-route 198.51.100.1/32 192.0.2.1
```

You do not need to include cost metric, distance, or tag parameters.

Display IPv4 Static Route Information

You can use show commands to display information about configured IPv4 routes, static routes, directly connected routes, routes configured for different protocols, the cost associated with each route, and the time the route has been available.

- Display the configured static routes.

```
device# show running-config vrf

vrf default-vrf
  static-route 192.0.2.0/24 192.0.2.2
  static-route 2001:db8:94::/64 set-tag 9999 interface ethernet 0/1 description this
is a connected static route
  static-route 2001:db8:101::/64 set-tag 9999 2001:db8::55 admin-distance 5 metric 10
no-recuse description all parameters
  static-route 2001:db8:187::/64 2001:db8::55
  static-route 198.51.100.0/24 set-tag 9999 192.0.2.5 admin-distance 5 metric 10 no-
recuse description all parameters
  static-route 2001:db8:1::/64 set-tag 100 null 0 description this is a drop route
  static-route 192.0.2.0/24 set-tag 9999 interface ethernet 0/1 description this is a
connected static route
  static-route 192.0.2.0/24 set-tag 100 null 0 description this is drop route
  static-route 2001:db8:d7::/64 set-tag 9999 2001:db8::29 interface port-channel 25
admin-distance 5 metric 10 description link-local nexthop
device#
```

- Display a list of active static routes and their connection times.

```
device# show ipv4 route vrf default-vrf static

Resilient Hash: Enabled
Ecmp Max Path: 128
Total number of IPv4 routes: 8, Max Routes: Not Set
'[x/y]' denotes [preference/metric]
198.51.100.2/32, static, [1/1], tag 0, 2m34s
  via 192.0.2.1, ethernet 0/13, [e4:db:ae:5c:24:16, ethernet 0/13]
203.0.113.3/32, static, [1/1], tag 0, 2m34s
  via 192.0.2.1, ethernet 0/13, [e4:db:ae:5c:24:16, ethernet 0/13]
device#
```

- Display all active IP routes and their connection times.

```
device# show ipv4 route vrf default-vrf

Resilient Hash: Enabled
Ecmp Max Path: 128
Total number of IPv4 routes: 13, Max Routes: Not Set
'[x/y]' denotes [preference/metric]
192.0.2.0/24, attached, [0/0], tag 0, 5m58s
  via direct, ethernet 0/11:1
192.0.2.1/32, , [0/0], tag 0, 5m58s
  via direct, ethernet 0/11:1
192.0.2.2/32, ARP, [3/0], tag 0, 5m58s
  via , ethernet 0/11:1, [00:16:3e:58:fb:20, ethernet 0/11:1.0]
198.51.100.0/24, attached, [0/0], tag 0, 5m58s
  via direct, ethernet 0/11:2
198.51.100.1/32, , [0/0], tag 0, 5m58s
  via direct, ethernet 0/11:2
198.51.100.2/32, ARP, [3/0], tag 0, 5m57s
```

```

    via , ethernet 0/11:2, [00:16:3e:58:fb:21, ethernet 0/11:2.0]
203.0.113.0/24, attached, [0/0], tag 0, 5m58s
    via direct, ethernet 0/11:3
203.0.113.1/32, , [0/0], tag 0, 5m58s
    via direct, ethernet 0/11:3
203.0.113.2/32, ARP, [3/0], tag 0, 5m58s
    via , ethernet 0/11:3, [00:16:3e:58:fb:22, ethernet 0/11:3.0]
192.0.2.10/32, ebgp, [20/0], tag 0, 5m32s
    via 192.0.2.2, ethernet 0/11:1
    via 198.51.100.2, ethernet 0/11:2
    via 203.0.113.2, ethernet 0/11:3
198.51.100.20/24, attached, [0/0], tag 0, 5m57s
    via direct, ethernet 0/32:1
198.51.100.20/32, , [0/0], tag 0, 5m57s
    via direct, ethernet 0/32:1
203.0.113.30/24, , [1/1], tag 0, 5m58s
    via 192.0.2.2, ethernet 0/11:1
    via 198.51.100.2, ethernet 0/11:2
    via 203.0.113.2, ethernet 0/11:3
device#

```

4. Display abbreviated information in the IPv4 routing table for all entries for the VRF instance.

```

device# show ipv4 route vrf default-vrf brief

Total number of IPv4 routes: 5, Max Routes: Not Set
Type Codes - B:BGP L:Local D:Direct/Connected S:Static A: Arp
BGP Codes - i:iBGP e:eBGP E:evpn
Hardware Status Codes - #:Failed

IP Prefix          Next Hop          Interface          Pref/Metric      Type
-----
198.51.100.0/24    DIRECT           tunnel testtunnel    0 0/0            D
198.51.100.0/24    DIRECT           tunnel testtunnel    1 0/0            D
192.0.2.0/24       DIRECT           ethernet 0/1         0/0              D
192.0.2.1/32       DIRECT           ethernet 0/1         0/0              L
192.0.2.0/24       198.51.100.1    tunnel testtunnel    0 20/0           Be
device#

```

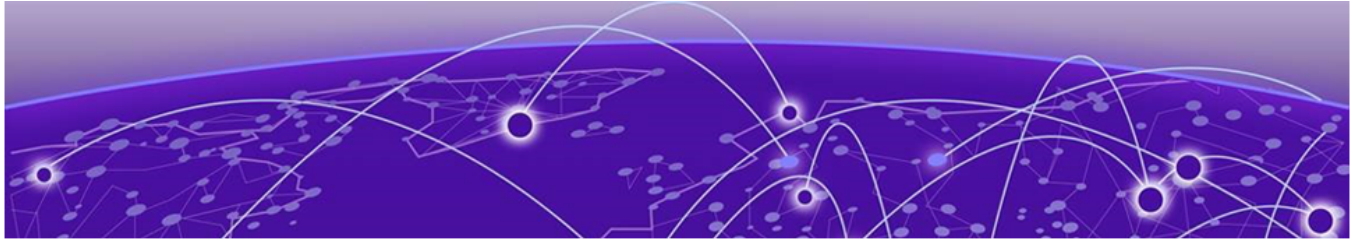

IPv6 Static Routing

- [IPv6 Static Routing](#) on page 67
- [IPv6 Static Route Availability](#) on page 68
- [Default VRF and User-Defined VRFs](#) on page 68
- [Configure a Basic IPv6 Static Route](#) on page 70
- [Configure an IPv6 Static Route with an Interface Next Hop](#) on page 70
- [Configure a BFD session for an IPv6 static route](#) on page 71
- [Disable Recursive Lookup for an IPv6 Static Route](#) on page 72
- [Add a Cost Metric or Administrative Distance to an IPv6 Static Route](#) on page 72
- [Configure an IPv6 Static Route to Use with a Route Map](#) on page 73
- [Configure an IPv6 Null Static Route](#) on page 73
- [Configure a Default IPv6 Static Route](#) on page 75
- [Configure IPv6 Static Routes for Load Sharing and Redundancy](#) on page 75
- [Remove an IPv6 Static Route](#) on page 77
- [Display IPv6 Static Route Information](#) on page 78

The following topics describe how to configure IPv6 static routing.

IPv6 Static Routing

Static routes can be used to specify desired routes, backup routes, or routes of last resort. Static routing can help provide load balancing.

Static routes are manually configured entries in the IPv6 routing table. Next hop functionality only supports IP addresses, not interfaces such as Ethernet, Port Channel (PO), or Virtual Ethernet (Ve) interfaces.

You can influence the preference a route is given by configuring a route metric higher than the default metric or giving the route an administrative distance.

Static routes can be configured to serve as any of the following types of route:

- Default routes
- Primary routes
- Backup routes
- Null routes for intentionally dropping traffic when the desired connection fails
- Alternate routes to the same destination (to help load balance traffic)

IPv6 Static Route Availability

IPv6 static routes remain in the IP route table only as long as the port or virtual interface used by the route is available and the next hop IP address is valid.

If the interface is not available and the next hop IP address is invalid, the software removes the static route from the route table. When the port or VE interface becomes available and the next hop is valid, the software adds the route to the route table.

You configure this feature so that the device adjusts to changes in network topology. The device does not continue trying to use routes on unavailable paths. Instead, it uses routes only when their paths are available.

Figure 5 shows an example of a static route that is configured on Switch A.

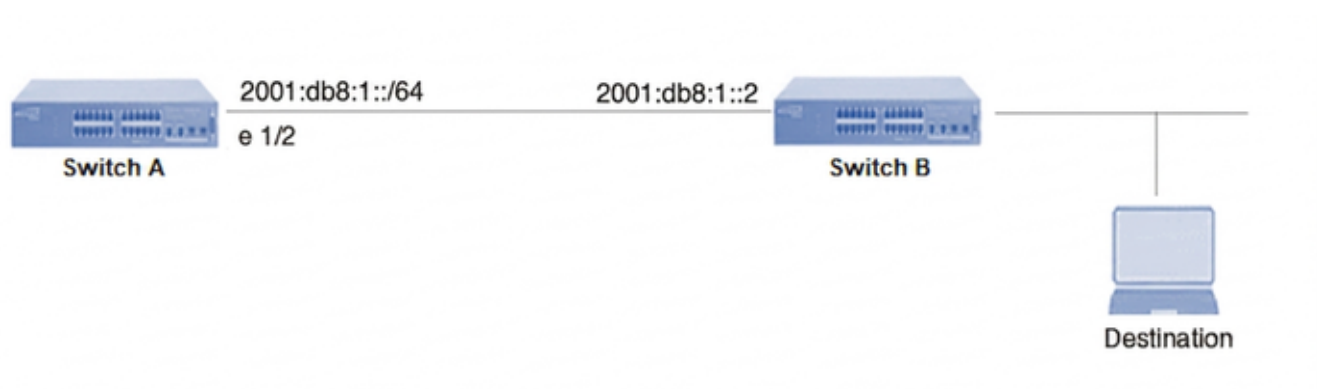

Figure 5: Example of an IPv6 static route

In Figure 5, the static route to 2001:db8:1::/64 was configured as follows, using 2001:db8:1::2 as the next hop gateway.

```
device(config-vrf-default-vrf)# static-route 2001:db8:1::/64 2001:db8:1::2
device(config-vrf-default-vrf)#
```

When you configure a static IP route, you specify the destination address for the route and the next hop gateway or Layer 3 interface through which the Layer 3 device can reach the route. The device adds the route to the IP route table. In this case, Switch A knows that 2001:db8:1::2 is reachable through port 1/2 and also assumes that local interfaces in that subnet are on the same port. Switch A deduces that IP interface 2001:db8:1::/64 is also on port 1/2.

Default VRF and User-Defined VRFs

You can use two types of VRF: the default VRF and user-defined VRFs.

Default VRF: The default VRF (always named default-vrf in the system) is used for general routing and is the primary VRF for most network traffic. It exists automatically on the device without any specific configuration. It acts as the device's global routing table. Interfaces are not assigned to the default VRF and must be explicitly moved to a user-defined VRF. Routes and interfaces in the default VRF are separate from those in user-defined VRFs, which prevents route leakage unless explicitly configured otherwise.

User-Defined VRFs: You create user-defined VRFs to isolate specific network traffic or services. Each VRF has an independent routing table and forwarding rules and is used to segregate and manage traffic for different departments, customers, or services in the same physical network infrastructure. They offer granular control over routing policies, interfaces, and security. They also offer flexibility and isolation for specialized network configurations when you use them for the following purposes:

- Creating virtual networks to separate tenants or virtual networks on the same physical infrastructure.
- Isolating services or applications (for example, web servers and database servers) onto their VRFs.
- Providing a sandboxed environment for testing and development.

The VRF handles general network operations, while user-defined VRFs provide customized isolation and routing for specific needs.

Following is an example of the default VRF after configuration:

```
device# show running-config vrf default-vrf

member loopback 1-2
static-route 203.0.113.0/24 192.0.2.1 enable-bfd profile default
static-route 203.0.113.0/24 192.0.2.1 enable-bfd profile default
static-route 203.0.113.0/24 192.0.2.1 enable-bfd profile default
static-route 203.0.113.0/24 192.0.2.1 enable-bfd profile default
static-route 198.51.100.0/24 192.0.2.1 enable-bfd profile default
static-route 198.51.100.0/24 192.0.2.1 enable-bfd profile default
static-route 198.51.100.0/24 192.0.2.1 enable-bfd profile default
static-route 192.0.2.0/24 192.0.2.1 enable-bfd profile default
device#
```

Following is an example of a user-defined VRF named `uservrf1` after configuration:

```
device# show running-config vrf uservrf1

member ethernet 0/1:1
member ethernet 0/1:2
member ethernet 0/1:3
member ethernet 0/1:4
member port-channel 1 vlan 1-60
member port-channel 2 vlan 61-120
member port-channel 3 vlan 121-180
member port-channel 4 vlan 181-240
static-route 203.0.113.0/24 192.0.2.1 enable-bfd profile default
static-route 203.0.113.0/24 192.0.2.1 enable-bfd profile default
static-route 203.0.113.0/24 192.0.2.1 enable-bfd profile default
static-route 203.0.113.0/24 192.0.2.1 enable-bfd profile default
static-route 203.0.113.0/24 198.51.100.1 enable-bfd profile default
static-route 203.0.113.0/24 198.51.100.1 enable-bfd profile default
static-route 198.51.100.0/24 192.0.2.1 enable-bfd profile default
static-route 198.51.100.0/24 192.0.2.1 enable-bfd profile default
static-route 192.0.2.0/24 192.0.2.1 enable-bfd profile default
static-route 203.0.113.0/24 192.0.2.1 enable-bfd profile default
static-route 2001:db8:2003:1::/64 2001:db8:1004:1::1 enable-bfd profile default
static-route 2001:db8:2003:13:1::/64 2001:db8:1004:13:1::1 enable-bfd profile default
static-route 2001:db8:2000::/64 2001:db8:1001:23:1::1 enable-bfd profile default
static-route 2001:db8:2002::/64 2001:db8:1003:21:1::1 enable-bfd profile default
static-route 2001:db8:2001::/64 2001:db8:1002:26:1::1 enable-bfd profile default
static-route 2001:db8:2002::/64 2001:db8:1003:2d:1::1 enable-bfd profile default
static-route 2001:db8:2003:1f:1::/64 2001:db8:1004:1f:1::1 enable-bfd profile default
```

```

static-route 2001:db8:2002::/64 2001:db8:1003:12:1::1 enable-bfd profile default
static-route 2001:db8:2002::/64 2001:db8:1003:39:1::1 enable-bfd profile default
static-route 2001:db8:2003:33:1::/64 2001:db8:1004:33:1::1 enable-bfd profile default
static-route 2001:db8:2003:38:1::/64 2001:db8:1004:38:1::1 enable-bfd profile default
static-route 2001:db8:2003:32:0/64 2001:db8:1004:33:1::1 enable-bfd profile default
static-route 2001:db8:2000:a:1::/64 2001:db8:1001:a:1::1 enable-bfd profile default
static-route 2001:db8:2000:b:1::/64 2001:db8:1001:b:1::1 enable-bfd profile default
static-route 2001:db8:2003:a:1::/64 2001:db8:1004:a:1::1 enable-bfd profile default
static-route 198.51.100.0/24 192.0.2.1 enable-bfd profile default
static-route 203.0.113.0/24 192.0.2.1 enable-bfd profile default
static-route 198.51.100.0/24 192.0.2.1 enable-bfd profile default
static-route 198.51.100.0/24 192.0.2.1 enable-bfd profile default
static-route 203.0.113.0/24 192.0.2.1 enable-bfd profile default
static-route 198.51.100.0/24 192.0.2.1 enable-bfd profile default
device#

```

Configure a Basic IPv6 Static Route

Specify the IPv6 destination address, the address mask, and the IPv6 address of the next hop.

Before you configure a basic IPv6 static route, you must enable IPv6 on at least one interface by configuring an IPv6 address or explicitly enabling IPv6 on that interface.

1. Access global configuration mode.

```
device# configure terminal
```

2. Specify a VRF name and enter VRF configuration mode.

```
device(config)# vrf default-vrf
```

3. Enter the route destination IPv6 address in hexadecimal with 16-bit values between colons, the address prefix length preceded by a slash, and the IPv6 address of the next hop gateway.



Note

The IPv6 address architecture is defined in [RFC 2373](#).

```
device(config-vrf-default-vrf)# static-route 2001:db8::/32 2001:db8:0:ee44::1
```

Configure an IPv6 Static Route with an Interface Next Hop

To configure an IPv6 static route that uses an interface as a next hop, you specify the IPv6 destination address, the address mask, and the interface of the next hop.

Before you configure an IPv6 static route that uses an interface as a next hop, you must enable IPv6 on at least one interface by configuring an IPv6 address or explicitly enabling IPv6 on that interface.

1. Access global configuration mode.

```
device# configure terminal
```

2. Specify a VRF name and enter VRF configuration mode.

```
device(config)# vrf default-vrf
```

3. Enter the route destination IPv6 address in hexadecimal with 16-bit values between colons, the address prefix length preceded by a slash, and the interface of the next hop.



Note

The IPv6 address architecture is defined in [RFC 2373](#).

```
device(config-vrf-default-vrf)# static-route 2001:db8:94::/64 interface ethernet 0/1
device(config-vrf-default-vrf)# static-route 2001:db8:95::/64 interface port-channel 25
device(config-vrf-default-vrf)# static-route 2001:db8:96::/64 interface ve 1
```

Configure a BFD session for an IPv6 static route

An IPv6 static route is associated with a static Bidirectional Forwarding Detection (BFD) session when the next hop for the static route matches the neighbor address of the static BFD neighbor, and BFD monitoring is enabled for the static route.

When static BFD is configured, the static route manager checks the routing table for a route to the BFD neighbor. If a route exists and the next hop is directly connected, a single-hop session is created. If the next hop is not directly connected, a multihop BFD session is created.

When the BFD session is up, a corresponding static route is added to the routing table. When the BFD session that monitors the static route goes down because the BFD neighbor is not reachable, static routes are removed from the routing table. These removed routes are replaced in the routing table when the BFD neighbor is reachable.

To use BFD for an IPv6 static route, you configure the static route and the corresponding static BFD separately.

1. Access global configuration mode.

```
device# configure terminal
```

2. Access BFD configuration mode.

```
device(config)# bfd
```

3. Create a BFD profile.

A BFD profile contains the BFD settings that are applied (or requested to be applied) to a routing protocol that is configured (registered) as a BGP client (meaning that it uses BFD for link failure detection instead of its own mechanism).

```
device(config-bfd)# profile profile1
```

4. Configure the interval (the desired rate at which to send BFD control packets to the neighboring system).

This includes the desired minimum transmit interval, minimum receive interval for BFD control packets at the local end point, and a multiplier value that helps to calculate the detection timeout of BFD sessions.

```
device(config-bfd-profile-profile1)# interval 5000 min-rx 10000 multiplier 4
```

5. Return to global configuration mode.

```
device(config-bfd-profile-profile1)# exit
device(config-bfd)# exit
```

- Specify a VRF name and enter VRF configuration mode.

```
device(config)# vrf default-vrf
```

- Enter the IP address, prefix length for the route destination network, the IP address for the next hop, and the BFD profile.



Note

Prefix lengths must be used as part of the address. For example, /64 is the prefix length in the 10:1::/64 address used in this step.

```
device(config-vrf-default-vrf)# static-route 2001:db8:1::/64 set-tag 100 null 0
description This is a drop route
```

Disable Recursive Lookup for an IPv6 Static Route

A device use the recursive lookup feature to search for another route if the original next-hop is not reachable. This feature is enabled by default.

If the next hop for a basic static route is directly reachable, it is added to the routing table. If that next hop is not reachable, the device can perform a lookup for another route (a recursive route). You can enable the recursive lookup feature in the default VRF or in a non-default VRF.



Note

An original next-hop is not considered resolved if it is reachable through a default route, such as ::/0.

- Access global configuration mode.

```
device# configure terminal
```

- Specify a VRF name and enter VRF configuration mode.

```
device(config)# vrf red
```

- To disable recursive lookup, enter the following command.

```
device(config-vrf-red)# static-route 2001:db8:101::/64 2001:db8:55::55 no-recurse
```

Add a Cost Metric or Administrative Distance to an IPv6 Static Route

You can influence route preference by adding a cost metric or an administrative distance to a static route.

Before you add a cost metric or an administrative distance to a static route, you must enable IPv6 on at least one interface by configuring an IPv6 address or explicitly enabling IPv6 on that interface.

- Access global configuration mode.

```
device# configure terminal
```

- Designate the route destination, the next hop, and the route priority.

Option	Description
Cost metric	The value is compared to the metric for other static routes in the IPv6 route table to the same destination. Two or more routes to the same destination with the same metric load share traffic to the destination. The

Option	Description
	value can be from 1 through 16. The default is 1. A route with a cost of 16 is considered unreachable.
Administrative distance	This value is compared to the administrative distance of all routes to the same destination. By default, static routes take precedence over learned protocol routes. However, to give a static route a lower priority than a dynamic route, give the static route the higher administrative distance. The value is preceded by the keyword <code>admin-distance</code> and can be from 1 to 254. The default is 1. A value of 255 is considered unreachable.

This example configures a static route with an administrative distance of 3:

```
device(config-vrf-default-vrf)# static-route 2001:db8::/64 2001:db8:0:ee44::1 admin-
distance 3
device(config-vrf-default-vrf)#
```

This example configures a static route with an administrative distance of 254:

```
device(config-vrf-default-vrf)# static-route 2001:db8::/64 2001:db8:0:ee44::1 admin-
distance 254
device(config-vrf-default-vrf)#
```

This example configures a static route with a cost metric of 2:

```
device(config-vrf-default-vrf)# static-route 2001:db8::/64 2001:db8:0:ee44::1 metric 2
device(config-vrf-default-vrf)#
```

Configure an IPv6 Static Route to Use with a Route Map

You can configure a static route with a tag that can be referenced in a route map.

Before you configure a static route with a tag that can be referenced in a route map, you must enable IPv6 on at least one interface by configuring an IPv6 address or explicitly enabling IPv6 on that interface.

1. Access global configuration mode.

```
device# configure terminal
```

2. Specify a VRF name and enter VRF configuration mode.

```
device(config)# vrf default-vrf
```

3. Enter the destination IP address and prefix length, the `set-tag` keyword, a tag number, and the next hop address.

```
device(config-vrf-default-vrf)# static-route 2001:db8:d7::/64 set-tag 9999 fe80::29
```

The tag "9999" in this example can be used in a route map.

Configure an IPv6 Null Static Route

You can configure a null static route to drop packets to a certain destination. This is useful when the traffic should not be forwarded if the preferred route is unavailable.



Note

You cannot add a null or interface based static route to a network if a static route of any type exists with the same metric you specify for the null or interface based route.

Figure 6 shows how an IPv6 null static route works with a standard route to the same destination.

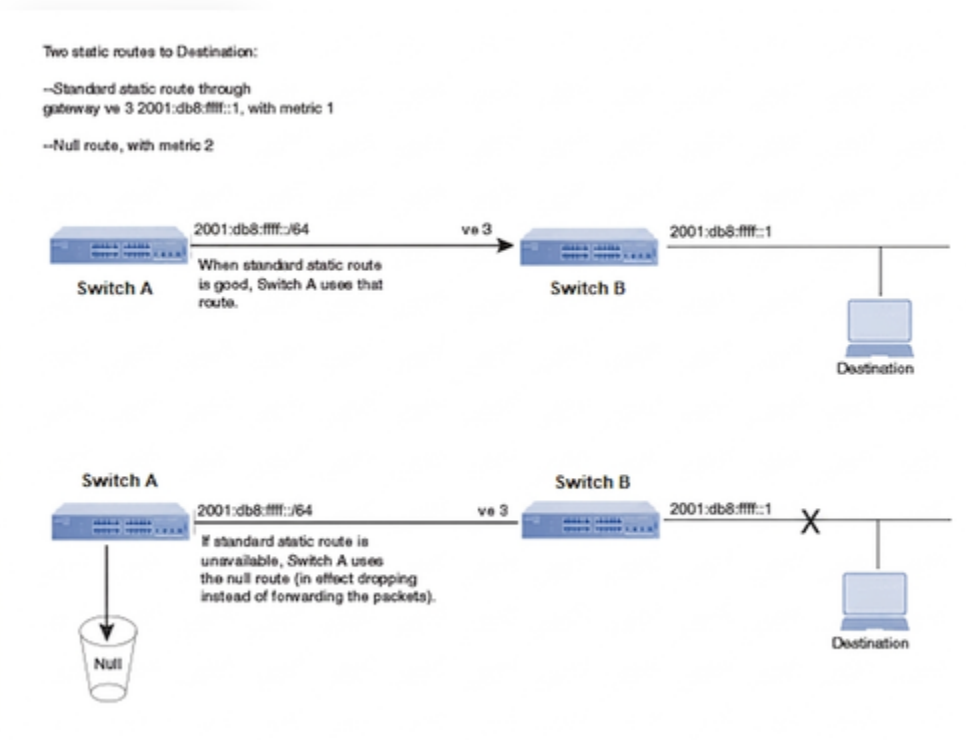

Figure 6: IPv6 null route and standard route to same destination

The following procedure creates a preferred route and a null route to the same destination. The null route drops packets when the preferred route is not available.

1. Enter global configuration mode.

```
device# configure terminal
```

2. Specify a VRF name and enter VRF configuration mode.

```
device(config)# vrf default-vrf
```

3. Configure the preferred route to a destination.

```
device(config-vrf-default-vrf)# static-route 2001:db8::/64 fe80::1 interface ve 3
```

This example creates a static route to IPv6 2001:DB8::0/64 destination addresses. These destinations are routed through link-local address fe80::1 and the next hop gateway Virtual Ethernet interface 3 (ve 3). The route uses the default cost metric of 1.

4. Configure the null route to the same destination, followed by the keyword null, a space, and a zero. Also specify a metric value of 2 (which is higher than the default metric of 1 as described previously).

```
device(config-vrf-default-vrf)# static-route 2001:db8::/64 null 0 metric 2
```

This example creates a null static route to the same destination. The metric is set higher so that the preferred route is used if it is available. When the preferred route becomes unavailable, the null route is used, and traffic to the destination is dropped.

The following example summarizes the commands in this procedure:

```
device# configure terminal
device(config)# vrf default-vrf
device(config-vrf-default-vrf)# static-route 2001:db8::/64 fe80::1 interface ve 3
device(config-vrf-default-vrf)# static-route 2001:db8::/64 null 0 metric 2
device(config-vrf-default-vrf)#
```

Configure a Default IPv6 Static Route

A router uses a default static route when there are no other default routes to a destination.

You cannot create a default route to a Virtual Ethernet (VE) or physical interface.

1. Access global configuration mode.

```
device# configure terminal
```

2. Specify a VRF name and enter VRF configuration mode.

```
device(config)# vrf default-vrf
```

3. Enter the destination route and network mask (::/0) followed by a valid next hop IP address.

```
device(config-vrf-default-vrf)# static-route ::/0 2001:db8:0:ee44::1
```

The following example summarizes the commands in this procedure:

```
device# configure terminal
device(config)# vrf default-vrf
device(config-vrf-default-vrf)# static-route ::/0 2001:db8:0:ee44::1
device(config-vrf-default-vrf)#
```

Configure IPv6 Static Routes for Load Sharing and Redundancy

You can configure multiple static routes to the same destination as load sharing or backup routes.

If you configure more than one static route to the same destination with different next hop gateways but the same metrics, the device load balances among the routes using a basic round robin method.

If you configure multiple static IP routes to the same destination with different next hop gateways and different metrics, the device always uses the route with the lowest metric. If this route becomes unavailable, the device fails over to the static route with the next lowest metric.

[Figure 7](#) shows two static routes to the same destination.

Two static routes to Destination:

–Standard static route through gateway ve 3 2001:db8:ffff:1, with metric 1

–Null route, with metric 2

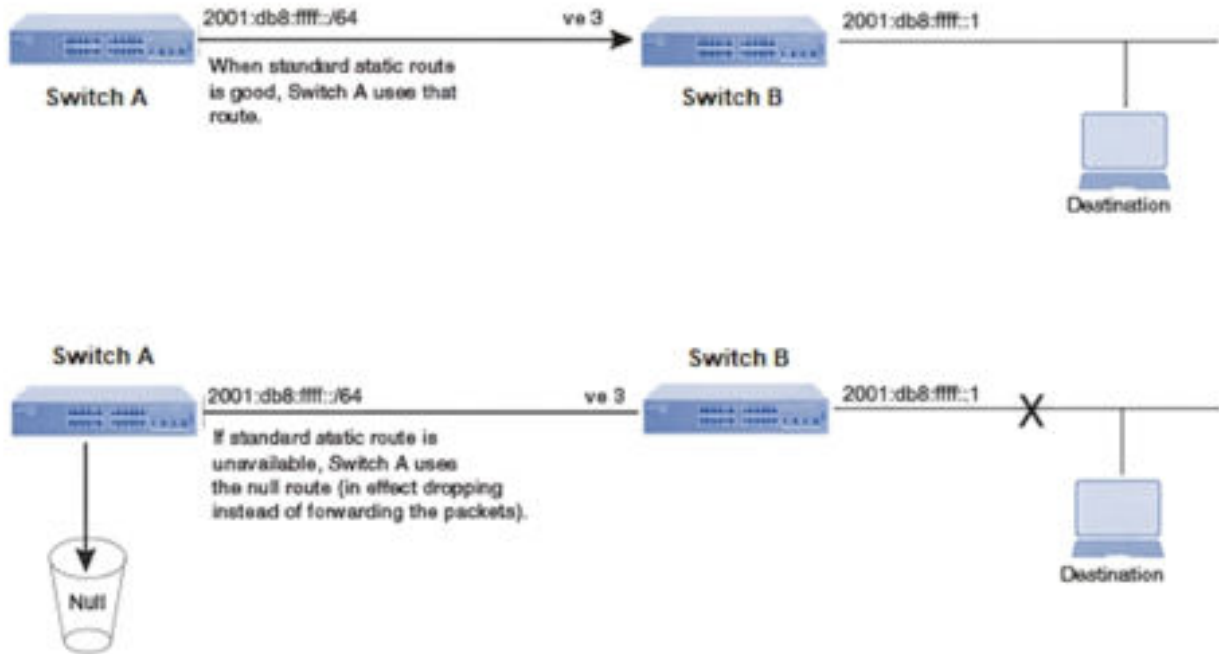

Figure 7: Two static routes to same destination



Note

You can also use administrative distance to set route priority. Assign the static route a lower administrative distance than other types of routes, unless you want the other route types to be preferred over the static route.

1. Access global configuration mode.

```
device# configure terminal
```

2. Specify a VRF name and enter VRF configuration mode.

```
device(config)# vrf default-vrf
```

3. Enter multiple routes to the same destination using different next hops.

```
device(config-vrf-default-vrf)# static-route 2001:db8::/64 2001:db8:2343:0:ee44::1
device(config-vrf-default-vrf)# static-route 2001:db8::/64 2001:db8:2344:0:ee44::2
```

This example creates two next-hop gateways for all 2001:DB8::0/64 destinations. Traffic alternates between the two paths.

- To prioritize multiple routes, use different metrics for each possible next hop.

```
device(config-vrf-default-vrf)# static-route 2001:db8::/64 2001:db8:2343:0:ee44::1
device(config-vrf-default-vrf)# static-route 2001:db8::/64 2001:db8:2344:0:ee44::2 2
```

This example creates an alternate route to all 2001:db8::0/64 destinations. The primary route uses 2001:db8:2343:0:ee44::1 as the next hop. The route has the default metric of 1 (the default metric is not entered in the CLI). If this path is not available, traffic is directed through 2001:db8:2344:0:ee44::2, which has the next lowest metric of 2.

Remove an IPv6 Static Route

Use the no form of the **static-route** command to remove an IPv6 static route.

- (Optional) View configured routes and confirm parameters.

```
device# show ipv6 route vrf default-vrf

Total number of IPv6 routes: 110, Max Routes: Not Set
'[x/y]' denotes [preference/metric]
2001:db8:152:1::2/128, static, [21/1], tag 0, 2m0s
  via 2001:db8:211:11:2::2, ethernet 0/5:2
  via 2001:db8:211:2:1::2, ethernet 0/5:1
2001:db8:152:2::1/128, attached, [0/0], tag 0, 3m11s
  via direct, loopback 522
2001:db8:152:2::2/128, static, [1/1], tag 0, 2m0s
  via 2001:db8:211:2:2::2, ethernet 0/5:2.2
2001:db8:152:3::1/128, attached, [0/0], tag 0, 3m11s
  via direct, loopback 523
2001:db8:211:2:4::2/128, ARP-local, [3/0], tag 0, 2m0s
  via , port-channel 122.3
2001:db8:211:11:2::1/128, local, [0/0], tag 0, 2m0s
  via direct, ethernet 0/5:2
2001:db8:211:11:2::2/128, local, [254/0], tag 0, 2m0s
  via 2001:db8:211:11:2::2, ethernet 0/5:2
```

- (Optional) Narrow the output to static routes only.

```
device# show ipv6 route vrf default-vrf static

Total number of IPv6 routes: 110, Max Routes: Not Set
'[x/y]' denotes [preference/metric]

2001:db8:152:1::2/128, static, [21/1], tag 0, 2m0s
  via 2001:db8:211:11:2::2, ethernet 0/5:2
  via 2001:db8:211:2:1::2, ethernet 0/5:1
2001:db8:152:2::2/128, static, [1/1], tag 0, 2m0s
  via 2001:db8:211:2:2::2, ethernet 0/5:2.2
```

- Access global configuration mode.

```
device# configure terminal
```

- Specify a VRF name and enter VRF configuration mode.

```
device(config)# vrf default-vrf
```

- Remove the static route, including the destination and next hop.

```
device(config-vrf-default-vrf)# no static-route 2001:db8:152:1::2/128
2001:db8:211:11:2::2
```

You do not need to include cost metric, distance, or tag parameters.

Display IPv6 Static Route Information

You can use show commands to display information about connected, static, and protocol routes.

1. Display the configured static routes.

```
vrf default-vrf
  static-route 192.0.2.0/24 198.51.100.2
  static-route 2001:db8:10:94::/64 set-tag 9999 interface ethernet 0/1 description
this is a connected static route
  static-route 2001:db8:10:101::/64 set-tag 9999 2001:db8:55::55 admin-distance 5
metric 10 no-recurse description all parameters
  static-route 2001:db8:10:200::/64 2001:db8:55::55
  static-route 198.51.100.0/24 set-tag 9999 203.0.113.5 admin-distance 5 metric 10 no-
recurse description all parameters
  static-route 2001:db8:10:1::/64 set-tag 100 null 0 description this is a drop route
  static-route 192.0.2.0/24 set-tag 9999 interface ethernet 0/1 description this is a
connected static route
  static-route 192.0.2.0/24 set-tag 100 null 0 description this is drop route
  static-route 2001:db8:10:d7::/64 set-tag 9999 fe80::29 interface port-channel 25
admin-distance 5 metric 10 description link-local nexthop
```

2. Display a list of active static routes and their connection times.

```
device# show ipv6 route vrf default-vrf static

Resilient Hash: Enabled
Ecmp Max Path: 128
Total number of IPv6 routes: 6, Max Routes: Not Set
'[x/y]' denotes [preference/metric]
2001:db8:2222::2/128, static, [1/1], tag 0, 2m36s
  via 2001:db8:1003::3, ethernet 0/13
2001:db8:3333::3/128, static, [1/1], tag 0, 2m36s
  via 2001:db8:1003::3, ethernet 0/13
device#
```

3. Display all active IP routes and their connection times.

```
device# show ipv6 route vrf default-vrf

Resilient Hash: Disabled
Ecmp Max Path: 128
Total number of IPv6 routes: 26, Max Routes: Not Set
'[x/y]' denotes [preference/metric]
2001:db8:1001::/64, attached, [0/0], tag 0, 1m12s
  via direct, ethernet 0/1:1
2001:db8:1001::1/128, local, [0/0], tag 0, 1m12s
  via direct, ethernet 0/1:1
2001:db8:2001::/64, attached, [0/0], tag 0, 1m4s
  via direct, ethernet 0/1:2.200
2001:db8:2001::1/128, local, [0/0], tag 0, 1m4s
  via direct, ethernet 0/1:2.200
2001:db8:3001::/64, attached, [0/0], tag 0, 17s
  via direct, ve 100
2001:db8:3001::1/128, local, [0/0], tag 0, 17s
device#
```

4. Display abbreviated information in the IPv6 routing table for all entries for the VRF instance.

```
device# show ipv6 route vrf default-vrf brief

Total number of IPv6 routes: 40, Max Routes: Not Set

IP Prefix                Next Hop                Interface                Pref/
```

```

Metric  Type
-----
-----
2001:db8:1521::/64    DIRECT          ve 1521
0/0                  D
2001:db8:1522::/64    DIRECT          ve 1522
0/0                  D
2001:db8:1523::/64    DIRECT          ve 1523
0/0                  D
2001:db8:1524::/64    DIRECT          ve 1524
0/0                  D
2001:db8:1621::/64    DIRECT          ve 1621
0/0                  D
2001:db8:5:3:1::/64   DIRECT          ethernet 0/1:3
0/0                  D
2001:db8:6:3:1::/64   DIRECT          ethernet 0/1:4.6
0/0                  D
2001:db8:152:1::1/128 DIRECT          loopback 521
0/0                  D
2001:db8:152:1::2/128 2001:db8:211:2:3:: port-channel 121
1/1                  S
                    2001:db8:211:2:2::
                    2001:db8:211:2:1::
2001:db8:152:2::1/128 DIRECT          loopback 522
0/0                  D
2001:db8:152:2::2/128 2001:db8:11:2:2::   ethernet 0/5:2.2
21/1                 S
2001:db8:152:3::1/128 DIRECT          loopback 523
0/0                  D
2001:db8:152:3::2/128 2001:db8:211:2:3::   port-channel 121
21/1                 S
2001:db8:152:4::1/128 DIRECT          loopback 524
0/0                  D
2001:db8:152:4::2/128 2001:db8:5:3:1::2   ethernet 0/1:3
21/1                 S
2001:db8:2:1:4::1/128 2001:db8:6:3:1::2   ethernet 0/1:4.6
21/1                 S
2001:db8:2:3:2::2/128 2001:db8:211:2:2::   ethernet 0/5:2.2
21/1                 S
2001:db8:2:3:3::2/128 2001:db8:211:2:3::   port-channel 121
21/1                 S
2001:db8:2:3:4::2/128                254/0           L
                    2001:db8:211:2:4::
                    port-channel 122.3
2001:db8:5:3:1::1/128 DIRECT          ethernet 0/1:3
0/0                  L
2001:db8:5:3:1::2/128 MAC: 00:05:03:01:00:02 ethernet 0/1:3
3/0                  A
2001:db8:6:3:1::1/128 DIRECT          ethernet 0/1:4.6
0/0                  L
2001:db8:6:3:1::2/128 MAC: 00:06:03:01:00:02 ethernet 0/1:4.6
3/0                  A
2001:db8:211:2:3::/127 DIRECT          port-channel 121
0/0                  D
2001:db8:211:2:4::/127 DIRECT          port-channel 122.3
0/0                  D
2001:db8:211:2:1::/128 MAC: f0:64:26:f7:91:32 ethernet 0/5:1
3/0                  A
2001:db8:211:2:2::/128 MAC: f0:64:26:f7:91:33 ethernet 0/5:2.2
3/0                  A
2001:db8:211:2:3::/128 MAC: f0:64:26:f7:91:04 port-channel 121
3/0                  A
2001:db8:211:2:4::/128 MAC: f0:64:26:f7:91:05 port-channel 122.3
3/0                  A
2001:db8:100:1:3::1/128 DIRECT          loopback 2

```

```
0/0          D
2001:db8:100:1:3::2/128 2001:db8:5:3:1::2    ethernet 0/1:3
21/1         S
2001:db8:160:1:3::1/128 DIRECT          loopback 601
0/0          D
2001:db8:160:1:3::2/128 2001:db8:6:3:1::2    ethernet 0/1:4.6
21/1         S
2001:db8:211:2:1::1/128 DIRECT          ethernet 0/5:1
0/0          L
2001:db8:211:2:2::1/128 DIRECT          ethernet 0/5:2.2
0/0          L
2001:db8:211:2:3::1/128 DIRECT          port-channel 121
0/0          L
2001:db8:211:2:4::1/128 DIRECT          port-channel 122.3
0/0          L
```

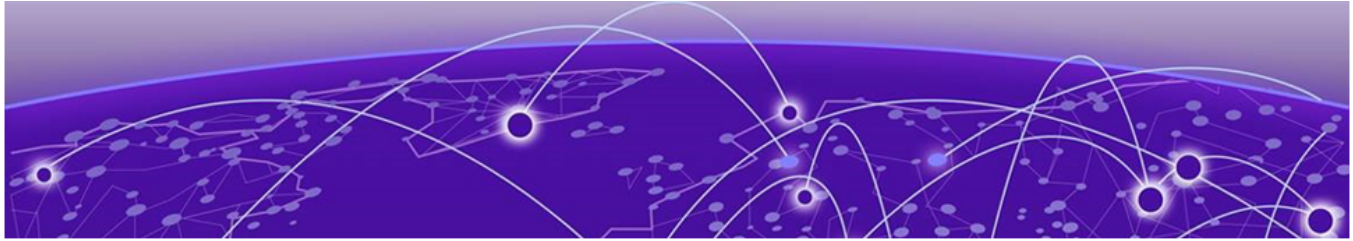

Layer 3 Policy Based Routing

[Routing Policy](#) on page 81

[Configuring Routing Policies](#) on page 81

Use this topic to learn about the Layer 3 policy-based routing (routing policy). This topic defines the route filtering object and container for applying routing policies to dynamic routing protocols.

Routing Policy

The Routing Policy feature provides control over routing information flow. You can configure policies to determine which routes are accepted or advertised by dynamic routing protocols.

You use the routing policy for the following purposes:

- Filtering routes imported into the routing table
- Controlling route exports
- Manipulating attributes such as the preference value, AS path, and community

How it works

Routing policies offer two control points: Before routing information is added to the BGP routing table and before routing information is advertised to the BGP peers.

Configuration commands are handled by the respective protocol microservice. Routes are evaluated against routing policies using the library's infrastructure.

Configuring Routing Policies

The Routing Policy configuration commands provide detailed information about routing policy configuration.

You can find all Routing Policy feature CLI commands in the *Extreme OS ONE SR Command Reference Guide*.

Creating Routing Policies

The following output shows how to configure match conditions, policy results, and policy actions.

```

route-policy
  prefix-set p1
    prefix 192.0.2.0/24 mask-range exact
    prefix 192.0.2.0/24 mask-range 24..32
  !

  prefix-set p2
    prefix 192.0.2.1/32 mask-range exact
  !

  bgp-defined-sets
    community-set c1
      member 1:1 100:56
      match-set-options any
    !

    community-set c2
      member 10:56 no-advertise no-export NO_EXPORT_SUBCONFED
    !

    ext-community-set ec1
      member 1:1
      match-set-options all
    !

    as-path-set as1
      member 10 11 65000 1.1 1[0-9][1-2] 1[1-5][4-7] 65001
    !

    as-path-set test
  !

  policy p1
    statement 1
      conditions
        match-prefix-set p1 any
        bgp-conditions
          local-pref-eq 10
          match-as-path-set as1 any
          match-community-set c1
        !
      !
      actions
        policy-result permit
        bgp-actions
          set-local-pref 100
          set-med 200
          set-route-origin egp
          set-next-hop 198.51.100.1
          set-community add c1
          set-ext-community add ec1
          set-as-path-prepend 65537 4
        !
      !
    !

    statement 3
      conditions
        match-prefix-set p1 any

```

The following output shows how to import and export policies at the peer group level:

```
vrf default-vrf
 member ethernet 0/2 vlan 1-8,33-36
 member ethernet 0/3 vlan 100
 member ve 37-44,69-72
 member loopback 1

router bgp
 local-as 1
 router-id 192.0.2.1

 address-family ipv4 unicast
 activate
 !

 address-family ipv6 unicast
 activate
 !

 peer-group PG_IPV4_1
 remote-as 1
 address-family ipv4 unicast
 export-policy p1
 activate
 !
 neighbor 198.51.100.0
 !

 peer-group PG_IPV4_3
 remote-as 65
 address-family ipv4 unicast
 activate
 !
 neighbor 198.51.100.1
 !
 !
 !
```

The following output shows how to display the routing policy configuration that is running currently on the device:

```
route-policy
 prefix-set prefix1
 prefix 192.0.2.0/24 mask-range exact
 prefix 198.51.100.0/24 mask-range exact
 prefix 203.0.113.0/24 mask-range 24..32
 !

 prefix-set prefix2
 prefix 2002:121:1::/64 mask-range exact
 prefix 2002:141:1::/64 mask-range exact
 !

 bgp-defined-sets
 as-path-set as1
 member 10, 10
 !
 !

 policy policy6
 statement 1
 actions
 policy-result permit
```

Timers	Interval(Sec)	Method	Remaining(Sec)
=====	=====	=====	=====
Connect Retry	31	Default	-
Hold Timer	0	Negotiated	-
Keepalive Timer	60	Default	-
Start Timer	5	System	-
Update Interval	0	Default	-

```
device#
```

Routing Policy Configuration Commands

You use the following commands to configure a routing policy.

- **prefix-set:** configures the prefix list.

```
device# configure terminal
device(config)# route-policy
device(config-route-policy)# prefix-set p1
device(config-route-policy-prefix-set-p1)# prefix 192.0.2.0/24
device(config-route-policy-prefix-set-p1)# prefix 198.51.100.0/24 mask-range exact
```

- **as-path-set:** configures the as path set.

```
device# configure terminal
device(config)# route-policy
device(config-route-policy)# bgp-defined-sets
device(config-route-policy-bgp-set)# as-path-set aspath1
device(config-route-policy-bgp-set-as-path-set-aspath1)# member 65535 65400
device(config-route-policy-bgp-set-as-path-set-aspath1)# exit
device(config-route-policy-bgp-set)# as-path-set aspath2
device(config-route-policy-bgp-set-as-path-set-aspath2)# member 45556423 45556420
device(config-route-policy-bgp-set-as-path-set-aspath2)# exit
device(config-route-policy-bgp-set)#
```

- **community-set:** configures the community set.

```
device# configure terminal
device(config)# route-policy
device(config-route-policy)# bgp-defined-sets
device(config-route-policy-bgp-set)# community-set comm1
device(config-route-policy-bgp-set-community-comm1)# match-set-options all
device(config-route-policy-bgp-set-community-comm1)# member 65535
device(config-route-policy-bgp-set-community-comm1)# exit
device(config-route-policy-bgp-set)#
device(config-route-policy-bgp-set)# community-set comm2
device(config-route-policy-bgp-set-community-comm2)# match-set-options invert
device(config-route-policy-bgp-set-community-comm2)# member no-advertise no-export
device(config-route-policy-bgp-set-community-comm2)# exit
```

- **ext-community-set:** configures the ext-community set.

```
device # configure terminal
device(config)# route-policy
device(config-route-policy)# bgp-defined-sets
device(config-route-policy-bgp-set)# ext-community-set ex-comm1
device(config-route-policy-bgp-set-ext-community-ex-comm1)# match-set-options any
device(config-route-policy-bgp-set-ext-community-ex-comm1)# member route-
target:65535:100 65535:200
device(config-route-policy-bgp-set-ext-community-ex-comm1)# exit
device(config-route-policy-bgp-set)# ex-comm2
device(config-route-policy-bgp-set-ext-community-ex-comm2)# match-set-options all
device(config-route-policy-bgp-set-ext-community-ex-comm2)# member route-
target:65510:100 route-target:65520:200
device(config-route-policy-bgp-set-ext-community-ex-comm2)# exit
```

- **route-policy:** configures route policy definition.

```
device# configure terminal
device(config)# route-policy
device(config-route-policy)# policy map1
device(config-route-policy-policy-map1)# statement 10
device(config-route-policy-policy-map1-stmt-10)# exit
```

- **match conditions:** indicates the container for all match conditions. All match directives for this statement block will be under conditions.

```
device# configure terminal
device(config)# route-policy
device(config-route-policy)# policy map1
device(config-route-policy-policy-map1)# statement 10
device(config-route-policy-policy-map1-stmt-10)# conditions
device(config-route-policy-policy-map1-stmt-10-conditions)#
```

- **prefix-set-name:** references a defined prefix set.

```
device# configure terminal
device(config)# route-policy
device(config-route-policy)# policy map1
device(config-route-policy-policy-map1)# statement 10
device(config-route-policy-policy-map1-stmt-10)# conditions
device(config-route-policy-policy-map1-stmt-10-conditions)# match-prefix-set pl any
```

- **BGP specific match statements (conditions):** indicates the container for all BGP specific match conditions. All match directives for this statement block will be under **bgp-conditions**.

```
device# configure terminal
device(config)# route-policy
device(config-route-policy)# policy map1
device(config-route-policy-policy-map1)# statement 10
device(config-route-policy-policy-map1-stmt-10)# conditions
device(config-route-policy-policy-map1-stmt-10-conditions)# bgp-conditions
device(config-route-policy-policy-map1-stmt-10-conditions-bgp-conditions)#
```

- **Match based on MED (match med, med-value):** multiple exit discriminator (MED) value to be matched against.

```
device# configure terminal
device(config)# route-policy
device(config-route-policy)# policy map1
device(config-route-policy-policy-map1)# statement 10
device(config-route-policy-policy-map1-stmt-10)# conditions
device(config-route-policy-policy-map1-stmt-10-conditions)# bgp-conditions
device(config-route-policy-policy-map1-stmt-10-conditions-bgp-conditions)# med-eq 20
```

- **Match based on ORIGIN:** indicates match based on route origin and type of origin.

```
device# configure terminal
device(config)# route-policy
device(config-route-policy)# policy map1
device(config-route-policy-policy-map1)# statement 10
device(config-route-policy-policy-map1-stmt-10)# conditions
device(config-route-policy-policy-map1-stmt-10-conditions)# bgp-conditions
device(config-route-policy-policy-map1-stmt-10-conditions-bgp-conditions)# origin-eq
igp
```

- **Match based on NEXTHOP:** matches the next hop IP address, and the IP address of the next hop interface.

```
device# configure terminal
device(config)# route-policy
device(config-route-policy)# policy map1
device(config-route-policy-policy-map1)# statement 10
device(config-route-policy-policy-map1-stmt-10)# conditions
```

```
device(config-route-policy-policy-map1-stmt-10-conditions)# bgp-conditions
device(config-route-policy-policy-map1-stmt-10-conditions-bgp-conditions)# next-hop-in
192.0.2.1
```

- Match based on AFI or SAFI: delete the configuration, matches AFI or SAFI parameters, represents AFI or SAFI types as defined in oc-bgp-types.

```
device# configure terminal
device(config)# route-policy
device(config-route-policy)# policy map1
device(config-route-policy-policy-map1)# statement 10
device(config-route-policy-policy-map1-stmt-10)# conditions
device(config-route-policy-policy-map1-stmt-10-conditions)# bgp-conditions
device(config-route-policy-policy-map1-stmt-10-conditions-bgp-conditions)# afi-safi-in
IPV4_UNICAST
```

- Match based on local-preference: Used to delete the configuration, matches local preference parameter, local preference value to be matched against.

```
device# configure terminal
device(config)# route-policy
device(config-route-policy)# policy map1
device(config-route-policy-policy-map1)# statement 10
device(config-route-policy-policy-map1-stmt-10)# conditions
device(config-route-policy-policy-map1-stmt-10-conditions)# bgp-conditions
device(config-route-policy-policy-map1-stmt-10-conditions-bgp-conditions)# local-pref-
eq 100
```

- Match based on route-type: Used to delete the configuration, match based on route type, represents type of route internal/external.

```
device# configure terminal
device(config)# route-policy
device(config-route-policy)# policy map1
device(config-route-policy-policy-map1)# statement 10
device(config-route-policy-policy-map1-stmt-10)# conditions
device(config-route-policy-policy-map1-stmt-10-conditions)# bgp-conditions
device(config-route-policy-policy-map1-stmt-10-conditions-bgp-conditions)# route-type
internal
```

- Match based on community-set: defines community-set match condition, name of the community-set that is being referenced.

```
device# configure terminal
device(config)# route-policy
device(config-route-policy)# policy map1
device(config-route-policy-policy-map1)# statement 10
device(config-route-policy-policy-map1-stmt-10)# conditions
device(config-route-policy-policy-map1-stmt-10-conditions)# bgp-conditions
device(config-route-policy-policy-map1-stmt-10-conditions-bgp-conditions)# match-
community-set comm1
```

- Match based on extended community-set: defines extended community-set match condition, name of the defined community set that is being reference.

```
device# configure terminal
device(config)# route-policy
device(config-route-policy)# policy map1
device(config-route-policy-policy-map1)# statement 10
device(config-route-policy-policy-map1-stmt-10)# conditions
device(config-route-policy-policy-map1-stmt-10-conditions)# bgp-conditions
device(config-route-policy-policy-map1-stmt-10-conditions-bgp-conditions)# match-ext-
community-set ex-comm1
```

- Match based on as-path-set: match as-path-set condition.

```
device# configure terminal
device(config)# route-policy
device(config-route-policy)# policy map1
```

```
device(config-route-policy-policy-map1)# statement 10
device(config-route-policy-policy-map1-stmt-10)# conditions
device(config-route-policy-policy-map1-stmt-10-conditions)# bgp-conditions
device(config-route-policy-policy-map1-stmt-10-conditions-bgp-conditions)# match-as-path-set aspath1 any
```

- **Actions:** all actions for this statement block will be under this one.

```
device# configure terminal
device(config)# route-policy
device(config-route-policy)# policy map1
device(config-route-policy-policy-map1)# statement 10
device(config-route-policy-policy-map1-stmt-10)# actions
device(config-route-policy-policy-map1-stmt-10-actions)#
```

- **BGP actions:** all BGP actions for this statement block will be under this one.

```
device# configure terminal
device(config)# route-policy
device(config-route-policy)# policy map1
device(config-route-policy-policy-map1)# statement 10
device(config-route-policy-policy-map1-stmt-10)# actions
device(config-route-policy-policy-map1-stmt-10-actions)# bgp-actions
device(config-route-policy-policy-map1-stmt-10-actions-bgp-actions)# set-as-path-prepend 110 5
device(config-route-policy-policy-map1-stmt-10-actions-bgp-actions)# set-community add comm1
device(config-route-policy-policy-map1-stmt-10-actions-bgp-actions)# set-ext-community add extcomm2
device(config-route-policy-policy-map1-stmt-10-actions-bgp-actions)# set-local-pref 50
device(config-route-policy-policy-map1-stmt-10-actions-bgp-actions)# set-med 20
device(config-route-policy-policy-map1-stmt-10-actions-bgp-actions)# set-next-hop 192.0.2.1
device(config-route-policy-policy-map1-stmt-10-actions-bgp-actions)# set-route-origin igp
device(config-route-policy-policy-map1-stmt-10-actions-bgp-actions)#
```

- **Policy match result:** select the final disposition for the route, either permit or deny. If a statement has match or action criteria and policy-result is not configured, then policy library will use the default value of DENY as result.

```
device# configure terminal
device(config)# route-policy
device(config-route-policy)# policy map1
device(config-route-policy-policy-map1)# statement 10
device(config-route-policy-policy-map1-stmt-10)# actions
device(config-route-policy-policy-map1-stmt-10-actions)# policy-result permit
device(config-route-policy-policy-map1-stmt-10-actions)#
```

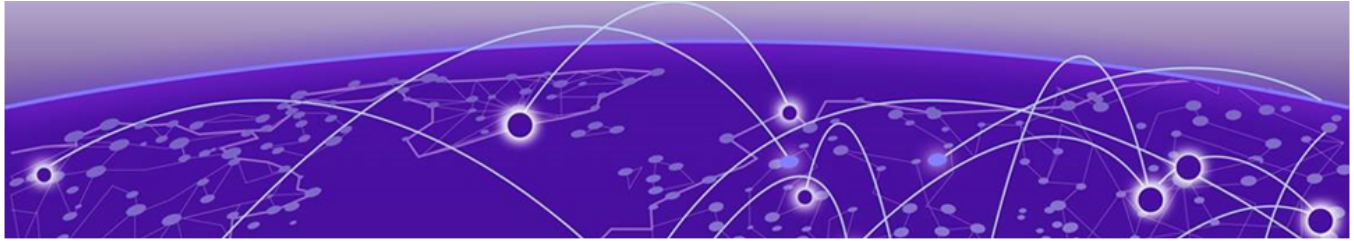

BGP4

- [BGP4 Capabilities and Limitations](#) on page 90
- [BGP4 Peering](#) on page 92
- [BGP4 Message Types](#) on page 95
- [BGP Best Path Selection](#) on page 98
- [BGP Route Origination through Redistribution](#) on page 99
- [BGP Route Origination through the Network](#) on page 101
- [BGP Route Origination through Default Route](#) on page 103
- [BGP Additional Paths](#) on page 106
- [BGP Allow-Own-AS](#) on page 111
- [BGP Local-AS-Forced](#) on page 112
- [Configure BGP MD5 Authentication](#) on page 113
- [BGP Multiprotocol](#) on page 114
- [BGP Route Refresh](#) on page 114
- [Configure EBGP Multihop: Extending BGP Reachability](#) on page 115
- [BGP Fast External Failover](#) on page 116
- [BGP IPv6](#) on page 117
- [BGP IPv6 Prefix Advertisement over IPv4 BGP Peers](#) on page 117
- [BGP Monitoring with Bidirectional Forwarding Detection \(BFD\)](#) on page 124
- [BGP Protocol Event Monitoring and Notification](#) on page 125
- [Configure BGP Address Families](#) on page 128
- [BGP4 Peer Groups](#) on page 128
- [BGP Four-Byte AS Number](#) on page 130
- [BGP Multi-VRF](#) on page 131
- [BGP Router-ID](#) on page 131
- [Configure BGP4 Route Reflection](#) on page 132
- [Configure BGP Prefix Independent Convergence](#) on page 133
- [BGP4 Graceful Restart](#) on page 137

The following topics describe how to configure Border Gateway Protocol version 4 (BGP4).

BGP4 Capabilities and Limitations

BGP4 is the standard protocol used on the Internet to route traffic between different autonomous systems (AS) while preventing routing loops. An AS is a group of

networks with shared routing and administrative characteristics, such as a company's internal network. These networks can use different internal routing protocols, but to communicate with other ASs, they need to use an exterior gateway protocol like BGP4. This protocol provides the exchange of routing information between devices in different ASs.

Limitation

The following features are not supported:

- BGP aggregation
- BGP confederation
- BGP route dampening

Supported BGP Features

BGP in Extreme OS ONE supports the following features:

- Four Octet AS Number
- Address Family
- Peer Group
- Static Neighbors
- Listen Range
- Authentication
- EBGp Multihop
- Fast External Failover
- Overriding Local-AS
- Timers
- Route Origination Redistribution
- Route Origination Network
- Route Origination Default-Information
- Route Selection and Download
- Route Advertisement
- Policy Enforcement
- Load Balancing or ECMP
- Add Path
- Route Reflection
- BFD
- Multi-Instance Support
- Route Refresh

BGP Communities, Extended Communities, and Route Filtering

BGP Communities

BGP Communities is a variable-length attribute that groups routes with common characteristics. Each community is represented by a 32-bit value, divided into an Autonomous System Number (ASN) and a locally defined value.

Types of Communities

Following are the community types:

- Standard Communities: 4-octet values for grouping routes
- Extended Communities: 8-octet values for larger grouping or categorization

Community Lists and Filtering

Following are the types of community lists and filtering:

- Community Lists: Define a list of communities for filtering or setting path attributes
- Extended Community Lists: Similar to community lists but for extended communities
- AS Path Lists: Filter routes based on AS numbers or regular expressions
- IP Prefix Lists: Match routes based on prefixes

Route Policy

A route policy defines the following attributes:

- Route Policy: This is a set of match conditions and parameter settings that control routes and change attributes.
- Linking Lists: Route policies reference filter lists, which are then applied to peer groups.
- Direction: You define the direction of route policy application (incoming or outgoing).

Key Points

You should use the following guidelines for community lists:

- The system has no default lists (configuration is required).
- The system links lists through route policies, not directly to peer groups.
- The system carries communities set by policy in BGP path attributes.
- The CLI has no specific command for triggering community sending (varies by vendor).
- The system does not support large communities.

For details on syntax and parameters for configuring Routing Policy, see the *Extreme OS ONE SR Release Notes*.

BGP4 Peering

BGP4 does not have neighbor detection capability. BGP4 neighbors (or peers) must be configured manually.

Neighbor address or listen-range must be configured.

BGP Static Peers

A BGP peer is a network device that participates in the Border Gateway Protocol (BGP) routing process, exchanging routing information with other peers. These peers can be from different Autonomous Systems (ASs) in External BGP (eBGP) or within the same AS in Internal BGP (iBGP).

Key Configuration Points

You should use the following guidelines when configuring BGP static peers:

- **Peer Identification:** Each BGP peer is identified by its IP address and AS number (for eBGP).
- **Peer Grouping:** Peers are grouped under a peer group, and group specific configurations are applied. This simplifies configuration and reduces administrative overhead.
- **No Default Peers:** No default peers exist in the system. Each peer must be manually configured.
- **Peer Configuration:** Peer specific configurations, such as IP address and AS number, are defined under a peer group. Configurations associated with a peer group can be overridden per peer.
- **Address Family:** A peer group can only include peers of the same address family (IPv4 or IPv6).
- **Link-Local Addresses:** Link local addresses can be used as BGP IPv6 peers, but must be associated with a specific interface due to their non-uniqueness.

Best Practices

When configuring BGP static peers, you should create a peer group for multiple peers with shared attributes and configure peer group specific attributes rather than individual peer configurations.

BGP Peering with Listen Range

Unlike Interior Gateway Protocol (IGP) neighbors, which are typically discovered automatically and are one hop away, Border Gateway Protocol (BGP) neighbors often require manual configuration and can be multiple hops away. As the number of BGP neighbors grows, so does the administrative burden.

You use the **listen-range** command to specify a range of trusted IPv4 or IPv6 addresses to be added dynamically as neighbors to a BGP peer group within a Virtual Routing and Forwarding (VRF) instance. You can also specify the number of BGP neighbors to be accepted for this listen range.

You can use the **listen-limit** *limit* keyword of the **listen-limit** command to specify the number of BGP neighbors (from 1 to 2400) accepted for the specified listen range.

The following example configures two BGP peer groups (group1 and group2) under a VRF instance named violet. In this example, group1 is assigned 200 as its remote autonomous system (AS) number and the IPv4 address range 192.0.2.0/24 as a listen

range. Also, group2 is assigned 300 as its remote AS number and the IPv6 address range 2001:db8:1::/64 as a listen range:

```
device# configure terminal
device(config)# vrf violet
device(config-vrf-violet)# router bgp
device(config-vrf-bgp)# peer-group group1
device(config-vrf-bgp-pg)# remote-as 200
device(config-vrf-bgp-pg)# listen-range 192.0.2.0/24
device(config-vrf-bgp-pg)# exit
device(config-vrf-bgp)# peer-group group2
device(config-vrf-bgp-pg)# remote-as 300
device(config-vrf-bgp-pg)# listen-range 2001:db8:1::/64
device(config-vrf-bgp-pg)#
```

Key Benefits

BGP Peering with Listen Range has the following benefits:

- Reduced administrative overhead: No need for static peer configurations
- Dynamic peer creation: New peers inherit attributes from the associated peer group
- Support for both IPv4 and IPv6 peers
- Bidirectional Forwarding Detection (BFD) support for dynamic neighbors
- MD5 authentication support for dynamic neighbors



Note

- No default listen range exists. It must be manually configured.
- Each IP address can only belong to one listen range.
- Static neighbors take precedence over dynamic neighbors.
- Link-local IPv6 neighbors are not supported.
- Peer group configurations are inherited by dynamic neighbors.

How Listen Range Works

The BGP Listen Range feature streamlines the process by allowing you to define a range of IP addresses that can establish dynamic peering relationships. When a device detects an incoming TCP session from an IP address within the specified range, it automatically creates a new BGP peer.

Limitations

Link-local addresses as BGP IPv6 peers are not supported.

BGP Peering with Next Hop Resolution

You can enable BGP next-hop address resolution via the default route in a specific address family forwarding table within a VRF instance. You can also do this through BGP routes. These two features are disabled by default.

Enable BGP Next-Hop Address Resolution via the Default Route

The following example configures a VRF instance named default-vrf. In this example, the VRF provides BGP next-hop address resolution via the default route within the IPv4 address family and unicast subaddress family:

```
device# configure terminal
device(config)# vrf default-vrf
device(config-vrf-default-vrf)# router bgp
device(config-vrf-bgp)# address-family ipv4 unicast
device(config-vrf-bgp-ipv4u)# next-hop-enable-default
device(config-vrf-bgp-ipv4u)#
```

Enable BGP Next-Hop Address Resolution through BGP Routes

The following example configures a VRF instance named default-vrf. In this example, the VRF provides BGP next-hop address resolution through BGP routes within the IPv6 address family and unicast subaddress family:

```
device# configure terminal
device(config)# vrf default-vrf
device(config-vrf-default-vrf)# router bgp
device(config-vrf-bgp)# address-family ipv6 unicast
device(config-vrf-bgp-ipv6u)# next-hop-recursion
device(config-vrf-bgp-ipv6u)#
```

BGP4 Message Types

BGP4 messages can be of the following types: OPEN, UPDATE, NOTIFICATION, KEEPALIVE, or ROUTE-REFRESH.

All BGP4 messages use a common packet header with the following byte lengths:

Marker	Length	Type	Data
16	2	1	variable



Note

All values in the following tables are in bytes.

OPEN message

After establishing TCP connection, BGP peers exchange OPEN message to identify each other.

Version	Autonomous system	Hold-time	BGP identifier	Optional parameter len	Optional parameters
1	2 or 4	2	4	1	4

Version

Only BGPv4 is supported.

Autonomous System

Both 2-byte and 4-byte autonomous system numbers are supported.

BGP Timers and Keepalives

BGP timers play a crucial role in maintaining session stability and ensuring fast convergence. By customizing these timers, you can optimize the network's performance. However, finding the right balance is key, as overly short timers can cause unnecessary session flaps, while longer timers can delay failure detection.

By understanding and customizing BGP timers, you can optimize the network's performance and ensure high availability. The following three primary timers can be customized:

1. **Keepalive Timer:** Sends periodic messages to ensure the connection between BGP peers remains active. Default interval is 60 seconds
2. **Hold Timer:** Defines the maximum time a BGP router waits without receiving messages from a neighbor before considering the session down. Default hold time is 180 seconds (3 minutes)
3. **Connect Retry Timer:** Manages the interval between attempts to re-establish a connection to a BGP peer after a session has been torn down

You can modify the Keepalive, Hold, and Connect timers at the peer group level. The timers and keepalives use the following default values:

- Keepalive: 60 seconds
- Hold: 180 seconds
- Connect: 30 seconds

BGP Identifier

The BGP Identifier indicates the router (or device) ID of the sender. In Extreme OS ONE, you must manually configure the BGP Identifier or router-id. If not configured, the system will not use a default value.

Parameter List

You can configure an optional list of additional parameters used in peer negotiation.

UPDATE message

The UPDATE message advertises new routes, withdraws previously advertised routes, or both. The UPDATE message passes BGP4 attributes to describe the characteristics of a BGP path by the advertising device.

Withdrawn routes length	Withdrawn routes	Total path attributes len	Path attributes	NLRI
2	variable	2	variable	variable

Withdrawn Routes Length

The Withdrawn Routes Length indicates the length of the next (withdrawn routes) field. It can be 0.

Withdrawn Routes

Withdrawn Routes contains a list of routes (or IP-prefix or Length) to indicate routes being withdrawn.

Total Path Attribute Len

The Total Path Attribute Len indicates the length of the next (path attributes) field. It can be 0.

Path Attributes

Path Attributes indicates characteristics of the advertised path. Possible attributes: Origin, AS Path, Next Hop, MED (Multi-Exit Discriminator), Local Preference, Atomic Aggregate, Aggregator, Community, extended-Communities. All well-known attributes, as described in [RFC 4271](#), are supported.

NLRI

Network Layer Reachability Information (NLRI) is the set of destinations whose addresses are represented by one prefix. This field contains a list of IP address prefixes for the advertised routes.

NOTIFICATION message

If an error causes the TCP connection to close, the closing peer sends a notification message to indicate the type of error.

Error code	Error subcode	Error data
1	1	variable

Error Code

The Error Code indicates the type of error:

- Message header
- Open message
- Update message
- Hold timer expired
- Finite state-machine
- Cease (voluntarily)

Error Subcode

The Error Subcode provides specific information about the reported error.

Error Data

Error Data provides data based on the error code and the subcode.

KEEPALIVE message

Because BGP does not exchanges route updates regularly to maintain a session, KEEPALIVE messages are sent to keep the session alive. The KEEPALIVE time specifies how frequently the device sends KEEPALIVE messages to its BGP4 neighbors.

A KEEPALIVE message contains the BGP header without a data field. The default KEEPALIVE time is 60 seconds and is configurable.

REFRESH message

A REFRESH message is sent to a neighbor requesting that the neighbor resend the route updates. This message is useful when the inbound policy has been changed.

BGP Best Path Selection

When multiple paths are available, Border Gateway Protocol (BGP) uses a step-by-step process to select the most preferred route to a destination. This process is critical in large-scale networks like the internet, where redundant paths between Autonomous Systems (ASs) or networks often exist.

How BGP Selects the Best Route

BGP evaluates a series of attributes in a specific order to determine the best route. The attributes are checked one by one, and the first matching criterion determines the best route.

Following is the typical sequence for route selection:

1. Highest Local Preference: BGP prefers routes with the highest LOCAL_PREF value, which indicates the preferred exit point within an AS.
2. Shortest AS Path: A shorter AS Path is preferred, as it indicates fewer hops and a more direct route.
3. Lowest Origin Type: BGP prefers routes with the lowest origin type: IGP (Interior Gateway Protocol) over EGP (Exterior Gateway Protocol) over INCOMPLETE.
4. Lowest MED (Multi-Exit Discriminator): A lower MED value is preferred to influence path selection between ASs.
5. EBGP over IBGP: Routes learned from External BGP (EBGP) neighbors are preferred over those from Internal BGP (IBGP) neighbors.
6. Lowest IGP Metric to Next-Hop: BGP prefers routes with the lowest IGP metric to the next-hop router.
7. Shortest Cluster Length: If all else is equal, BGP prefers routes with the shortest cluster length.
8. Older Route: If all attributes are equal, BGP might prefer the older route.
9. Lowest Router ID: Finally, BGP uses the lowest router ID to break ties.

Key Points

These steps apply to IPv4 and IPv6 unicast routes. You cannot modify them. BGP EVPN routes have additional route calculation steps.

BGP Route Origination through Redistribution

BGP establishes sessions with peers to exchange routes, which can be either received from other peers or locally originated. One way to originate routes within BGP is through route redistribution, which involves importing routes from one routing protocol into BGP or vice versa. Networks running different routing protocols can exchange routing information, providing greater flexibility in managing multiple routing domains.

How BGP Redistribution Works

When routes are redistributed into BGP, they undergo the regular route selection process. If selected, they go through the regular route advertisement process.

The imported routes inherit default path attribute values, including the following values:

- Local Preference: 100
- Origin: Incomplete
- AS PATH: Empty
- Communities: None
- Ext-Communities: None

Key Points

BGP redistribution operates in the following ways:

- Redistribution is disabled by default and requires the **table-connections** command to be configured.
- Route policy association with redistribution is not currently supported.
- Redistributed routes take on default path attribute values.
- BGP considers protocol routes from the best source as the routes to be redistributed.
- BGP cannot redistribute its own routes to prevent routing loops, although it can pick routes from other VRFs (not currently supported).
- Redistributed routes undergo regular route selection and advertisement within BGP.

Configuring BGP Redistribution

To enable BGP redistribution, you use the **table-connections** command to enter VRF table connections configuration (conf-vrf-*name*-table-connections) mode. This is the mode for configuring table connection settings for the source and destination protocols for route redistribution for a specified address family. For details about this command, see the *Extreme OS ONE SR Command Reference Guide*.

While in this mode, you use the **src-protocol** command to add table connections configurations for route redistribution to a specific VRF instance. This command configures the routing of redistribution between pairs of protocols for specified address

families within a VRF instance. You use this command to add pairs of protocols and the address family (IPv4 or IPv6) that applies to each pair. For details about this command, see the *Extreme OS ONE SR Command Reference Guide*.

The following example enables table connections configurations for a VRF instance named red and configures a connections table with four pairs of protocols and the address family (either IPv4 or IPv6) that applies to each pair:

```
device# configure terminal
device(config)# vrf red
device(config-vrf-red)# table-connections
device(config-vrf-red-table-connections)# src-protocol connected dst-protocol bgp address-family ipv6
device(config-vrf-red-table-connections)# src-protocol connected dst-protocol bgp address-family ipv4
device(config-vrf-red-table-connections)# src-protocol static dst-protocol bgp address-family ipv4
device(config-vrf-red-table-connections)# src-protocol static dst-protocol bgp address-family ipv6
device(config-vrf-red-table-connections)#
```

The following example displays the configuration of a VRF instance named red that is running currently on the device. In this example, the instance is configured with a connections table containing several pairs of protocols and the corresponding address family for each pair:

```
device# show running-config vrf

vrf red
table-connections
src-protocol connected dst-protocol bgp address-family ipv6
src-protocol connected dst-protocol bgp address-family ipv4
src-protocol static dst-protocol bgp address-family ipv4
src-protocol static dst-protocol bgp address-family ipv6
device#
```

If you have enabled the redistribution of routes from one protocol to another for the specified address family, BGP checks for the default route in the redistribution slot and does not add it to the BGP routing table. But if this default route from redistribution must be used, you enter the **send-default-route** command for the specified address family to ensure its redistribution to the BGP routing table (thereby advertising it to neighbors). For details about this command, see the *Extreme OS ONE SR Command Reference Guide*.

The following example configures a routing process under a VRF instance named violet. This example creates an IPv4 unicast address family in the routing process and overrides the exclusion of the default route from the BGP routing table when redistribution of routes between protocols is enabled:

```
device# configure terminal
device(config)# vrf violet
device(config-vrf-violet)# router bgp
device(config-vrf-default-bgp)# address-family ipv4 unicast
device(config-vrf-bgp-l2vpn-evpn)# send-default-route
device(config-vrf-bgp-l2vpn-evpn)#
```

The following example displays the configuration of a VRF instance named violet that is running currently on the device. This example overrides the exclusion of the default

route from the BGP routing table when redistribution of routes between protocols is enabled for the IPv4 unicast address family and the IPv6 unicast address family:

```
device# show running-config vrf violet

vrf violet
  table-connections
    src-protocol static dst-protocol bgp address-family ipv4
    src-protocol static dst-protocol bgp address-family ipv6
  !
  static-route 192.0.2.1/32 192.0.2.101 enable-bfd profile default
  static-route 2001:db8:20:1:1::/64 2001:db8:30:1:1::65 enable-bfd profile computes
  static-route 192.0.2.8/32 192.0.2.201 enable-bfd profile default
  static-route 2001:db8:20:1:5::/64 2001:db8:30:1:5::65 enable-bfd profile computes
  static-route 198.51.100.0/24 198.51.100.10
  static-route 2001:db8:26:1:1:100::/64 2001:db8:25:1:1::100
  router bgp
    local-as 10001
    router-id 203.0.113.2
    graceful-restart
    use-multiple-paths ebgp maximum-paths 8
    address-family ipv4 unicast
      graceful-restart
      send-default-route
      activate
    !
    address-family ipv6 unicast
      graceful-restart
      send-default-route
      activate
    !
  !
!
device#
```

BGP Route Origination through the Network

When establishing BGP sessions with peers, networks exchange routes – either learned from other peers or locally originated. One way to originate routes in BGP is through the **network** command, which lets you selectively inject local IGP routes into the BGP routing table.

How it Works

When a route is added via the **network** command, it undergoes the standard route selection process. If selected, it is then advertised to peers through the regular route advertisement process. The route must be available in the specified address family (such as IPv4 or IPv6 unicast).

Key Differences and Benefits

Unlike route redistribution, the **network** command provides granular control over which routes are imported into the BGP routing table. Imported routes inherit default path attribute values such as the following values:

- Local Preference: 100
- Origin: IGP
- AS PATH: Empty
- Communities: None
- Ext-Communities: None

Key Points

BGP route origination through a network has the following limitations:

- No default network routes exist. Explicit configuration of these routes is required.
- Route policy association with the **network** command is not supported.
- Network routes assume default path attribute values.
- The best source for network routes cannot be BGP itself.
- Imported routes follow standard route selection and advertisement processes within BGP.

Configuring BGP Route Origination through Network

The following example configures a routing process under a VRF instance named violet. This example creates two address families and advertises a network in each one:

```
device# configure terminal
device(config)# vrf violet
device(config-vrf-violet)# router bgp
device(config-vrf-bgp)# address-family ipv4 unicast
device(config-vrf-bgp-ipv4u)# network 192.0.2.1/32
device(config-vrf-bgp-ipv4u)# exit
device(config-vrf-bgp)# address-family ipv6 unicast
device(config-vrf-bgp-ipv6u)# network 2001:db8:1:1::2/32
device(config-vrf-bgp-ipv6u)#
```

The following example displays the configuration of a VRF instance named violet that is running currently on the device. In this example, the instance contains a routing process with two address families and an advertised network in each one:

```
device# show running-config vrf violet

vrf violet
  router bgp
    address-family ipv4 unicast
      network 192.0.2.1/32
    !
    address-family ipv6 unicast
      network 2001:db8:1:1::2/32
      activate
    !
  !
```

```
!  
device#
```

BGP Route Origination through Default Route

In BGP, routers advertise routes to neighbors with next-hop information. The receiving device validates and installs these routes in its routing table, pointing to the next hop. When incoming traffic is received, the device performs a routing table lookup, making a routing decision based on the longest match. If no match is found, the packet is typically dropped.

However, in certain scenarios, a device may want to attract traffic when there's no matching route. To achieve this, it can advertise a default route (0.0.0.0/0 for IPv4 or ::/0 for IPv6) to its neighbors. This special route always matches, and the receiving neighbors install it in their hardware, pointing to the advertised next hop. This feature overrides exclusion of the default route from the BGP routing table when redistribution of routes between protocols is enabled for the specified address family.

A BGP speaker can advertise default routes to its neighbors to attract traffic or act as a default gateway. There are multiple methods to advertise default routes in BGP, including the following commands:

1. **network**
2. **redistribute**
3. **default-route-originate** under a specific BGP peer group
4. **send-default-route** under a specific BGP IPv4 or IPv6 address family

These methods allow BGP speakers to advertise default routes, enabling flexible routing decisions and traffic management.

CLIs for BGP Default Route Origination at the Global Level

Follow this procedure to configure BGP route origination through a default route globally:

1. Access global configuration mode.

```
device# configure terminal
```

2. Specify the VRF name and enter VRF configuration mode. You can specify the default VRF (named default-vrf) or a user-created VRF.

```
device(config)# vrf violet
```

3. Configure a BGP routing process within the VRF instance and enter BGP configuration mode.

```
device(config-vrf-violet)# router bgp
```

4. Configure an address family routing table for the BGP routing process within the VRF instance and enter BGP address family configuration mode. You can specify **ipv4** or **ipv6** for the address family. You can specify **unicast**, **multicast**, or **evpn** for the address prefixes.

```
device(config-vrf-bgp)# address-family ipv4 unicast
```

5. Enable BGP route origination through the default route for the specified address family.

```
device(config-vrf-bgp-ipv4u)# send-default-route
```

6. (Optional) Enable BGP route origination through the default route for the specified address family by advertising a network to its routing table. The following command identifies which networks to advertise from your local networks, and if BGP finds a network in the local routing table that matches the network statement (and the mask), then BGP advertises it.

```
device(config-vrf-bgp-ipv4u)# network 0.0.0.0/0
```

7. Activate the routing table.

```
device(config-vrf-bgp-ipv4u)# activate
```

8. (Optional) Verify the configuration.

```
device(config-vrf-bgp-ipv4u)# do show running-configuration vrf violet

vrf violet

  table-connections
    src-protocol static dst-protocol bgp address-family ipv4
    src-protocol static dst-protocol bgp address-family ipv6
  !
  static-route 192.0.2.1/32 192.0.2.101 enable-bfd profile default
  static-route 2001:db8:20:1:1::/64 2001:db8:30:1:1::65 enable-bfd profile computes
  static-route 192.0.2.8/32 192.0.2.201 enable-bfd profile default
  static-route 2001:db8:20:1:5::/64 2001:db8:30:1:5::65 enable-bfd profile computes
  static-route 198.51.100.0/24 198.51.100.10
  static-route 2001:db8:26:1:1:100::/64 2001:db8:25:1:1::100
  router bgp
    local-as 10001
    router-id 203.0.113.2
    graceful-restart
    use-multiple-paths ebgp maximum-paths 8
    address-family ipv4 unicast
      graceful-restart
      send-default-route
      network 0.0.0.0/0
      activate
    !
    address-family ipv6 unicast
      graceful-restart
      send-default-route
      network 2001:db8:10:1:1::2/32
      activate
    !
  !
!
device#
```

CLIs for BGP Route Default Route Origination at the Peer Group Level

Using network and redistribution, a default route is added into the BGP routing table and is advertised to all peers and peer groups that have negotiated a given AFI or SAFI. This is not always desirable where you must advertise to limited or few peer groups. To do so, use the **default-route-originate** command under a peer group to which the default route must be originated.

Follow this procedure to configure BGP route origination through a default route for a specific BGP peer group:

1. Access global configuration mode.

```
device# configure terminal
```

2. Specify the VRF name and enter VRF configuration mode. You can specify the default VRF (named default-vrf) or a user-created VRF.

```
device(config)# vrf violet
```

3. Configure a BGP routing process within the VRF instance and enter BGP configuration mode.

```
device(config-vrf-violet)# router bgp
```

4. Specify a BGP peer group.

```
device# (config-vrf-bgp)# peer-group towards_leaf
```

5. Configure an address family routing table for the BGP routing process within the VRF instance and enter BGP peer group address family configuration mode. You can specify **ipv4** or **ipv6** for the address family. You can specify **unicast**, **multicast**, or **evpn** for the address prefixes.

```
device(config-vrf-bgp-pg)# address-family ipv4 unicast
```

6. Enable BGP route origination through the default route for the specified address family.

```
device(config-vrf-bgp-pg-ipv4u)# default-route-originate
```

7. (Optional) Verify the configuration.

```
device(config-vrf-bgp-pg-ipv4u)# do show running-configuration vrf violet

vrf violet
  table-connections
    src-protocol static dst-protocol bgp address-family ipv4
    src-protocol static dst-protocol bgp address-family ipv6
  !
  static-route 192.0.2.1/32 192.0.2.101 enable-bfd profile default
  static-route 2001:db8:20:1:1::/64 2001:db8:30:1:1::65 enable-bfd profile computes
  static-route 192.0.2.8/32 192.0.2.201 enable-bfd profile default
  static-route 2001:db8:20:1:5::/64 2001:db8:30:1:5::65 enable-bfd profile computes
  static-route 198.51.100.0/24 198.51.100.10
  static-route 2001:db8:26:1:1:100::/64 2001:db8:25:1:1::100
  router bgp
    local-as 10001
    router-id 203.0.113.2
    graceful-restart
    use-multiple-paths ebgp maximum-paths 8
    peer-group towards_leaf
      address-family ipv4 unicast
        default-route-originate
      !
      address-family ipv4 unicast
        graceful-restart
        send-default-route
        activate
      !
      address-family ipv6 unicast
        graceful-restart
        send-default-route
        activate
      !
```

```
!  
!  
device#
```

BGP Additional Paths

The BGP Additional Paths feature advertises and receives multiple paths for a given prefix, promoting path diversity. This is achieved by introducing a path identifier (ID) that extends the existing NLRI encoding. This feature enhances path diversity and reduces path hiding. Key aspects of this feature include the following functionality:

- Negotiation: Must be negotiated before exchanging additional paths.
- Path ID: A four-octet value that uniquely identifies each path within the NLRI.
- RIB-IN table: Prefix and path ID together serve as the key, enabling multiple route sources from a given peer for the same route.
- Path diversity: Multiple paths can be received and maintained, thereby improving network resilience.
- Faster recovery: The network can recover more quickly from next-hop failures.

By default, BGP routers only advertise their best path to neighbors, replacing the current path when a better one is found. This leads to "path hiding," where many possible paths are unknown to some routers.

The BGP Additional Paths feature addresses this limitation by advertising multiple paths for the same prefix, enabling path diversity. This feature adds a unique path identifier to each path, allowing for more efficient routing.

Key Components

By implementing the following key components, the BGP Additional Paths feature enhances path diversity and improves network resilience in the following ways:

- Configures receive-mode functionality: The system sets up the feature at the global AFI or SAFI level or peer-group AFI SAFI level to allow the router to receive additional paths.
- Negotiates ADD-PATH capability: The system negotiates the ADD-PATH capability with its peers in "receive" mode only.
- Modifies NLRI processing: The system updates the NLRI processing behavior to decode extended NLRI and extract the path ID for each path.

Implementation Considerations and Limitations

Without the Additional Paths feature, a BGP device advertises only its best path to neighboring devices. When a device receives multiple paths for the same prefix from the same peer, it replaces the previous path. With the Additional Paths feature, BGP devices can negotiate the ability to accept multiple paths from the same peer. Each path is assigned a unique path identifier.

The Additional Paths feature has the following implementation considerations and limitations:

- The feature is not enabled by default and requires explicit configuration.
- The feature supports IPv4 and IPv6 unicast address families but not BGP EVPN.
- Local changes to the capability take effect only after a session reset.
- The feature supports receiving additional paths. It does not support ending additional paths or advertising additional paths to peers.
- The system can receive multiple paths for a given prefix from the same peer.
- The device can negotiate the Additional Paths capability with its peers.

CLI commands are available to enable the feature at the global AFI-SAFI and peer-group AFI-SAFI levels.

Various **show** commands are available to display Additional Paths information. The **show neighbor** command displays the Add-Path mode status of the local device and the peer device as well.

Configuring BGP Additional Paths

The following example configures a routing process under a VRF instance named violet. This example creates and activates two address families. In this example, additional paths receive functionality is enabled for each address family:

```
device# configure terminal
device(config)# vrf violet
device(config-vrf-violet)# router bgp
device(config-vrf-bgp)# address-family ipv4 unicast
device(config-vrf-bgp-ipv4u)# add-paths receive
device(config-vrf-bgp-ipv4u)# activate
device(config-vrf-bgp-ipv4u)# exit
device(config-vrf-bgp)# address-family ipv6 unicast
device(config-vrf-bgp-ipv6u)# add-paths receive
device(config-vrf-bgp-ipv6u)# activate
device(config-vrf-bgp-ipv6u)#
```

The following example displays the configuration of a VRF instance named violet that is running currently on the device. In this example, the instance contains a routing process with two activated address families. Each address family uses the additional paths receive functionality:

```
device# show running-config vrf violet

vrf violet
  router bgp
    address-family ipv4 unicast
      add-paths receive
      activate
    !
    address-family ipv6 unicast
      add-paths receive
      activate
    !
  !
device#
```

Support Additional Paths in BGP

By default, when a new path or update is received for the same prefix, Extreme OS ONE BGP handles it according to implicit withdraw behavior. However, with the additional paths feature, Extreme OS ONE BGP can be configured to accept and process multiple paths for the same prefix. The number of additional paths that can be supported depends on the RIB-IN soft limit of the BGP peer. This limit determines the maximum number of routes that can be stored in the BGP routing table, which in turn affects the number of additional paths that can be accepted and processed.



Note

Enabling the Additional Paths feature will reset the BGP session to renegotiate the capability and process updated NLRI preceded by path-id.

Enabling Additional Paths

You can enable this feature at the global AFI or SAFI level (to apply to all peers) or at the peer-group AFI or SAFI level (to apply to a specific peer group).

Configuring Additional Paths in BGP

To enable additional paths in receive mode, use the following command:

```
dutb(config-vrf-bgp-ipv4u)# add-paths receive
```

This command enables the receive mode for additional IPv4 unicast paths, allowing Extreme OS ONE BGP to accept and process multiple paths for the same IPv4 prefix.

Verification

After enabling the feature, you can verify the configuration using the **show running-config** command:

```
dutb(config-vrf-bgp-ipv4u)# do show running-config
```

This command displays the current configuration, including the **add-paths receive** command.

Capability Negotiation for Add Path

The Add Path capability is identified by capability code 69, with a variable length. The Value field contains the following information:

1. AFI (Address Family Identifier): Specifies the address family (IPv4 or IPv6)
2. SAFI (Subsequent Address Family Identifier): Specifies the subsequent address family
3. Send/Receive: Indicates the ability of the sender to receive or send multiple paths:
 - Send multiple paths to its peer (value 2)
 - Receive multiple paths from its peer (value 1)
 - Both (value 3)

Since Extreme OS ONE BGP only supports receive mode. The Send/Receive field value will always be 1 when sending capability information to neighbors.

NLRI Processing

After negotiating the Additional Paths capability, BGP uses update message NLRI to receive multiple paths. The NLRI format is updated to include a new field, Path Identifier (Path-ID), which is 4 octets in length and precedes the path itself. The Path-ID uniquely identifies each path for a prefix within a peering session.

The following is the updated NLRI format:

```
+-----+
| Path Identifier (4 octets) |
+-----+
| Length (1 octet)         |
+-----+
| Prefix (variable)        |
+-----+
```

Path-Id uniquely identifies each path for a prefix within a peering session.

BGP receives multiple paths but installs only the best paths to the Unified Forwarding Table Manager (UFTM) based on ECMP configuration and limits set by the **use-multiple-paths** command. You use this command to configure the maximum number of paths to install for ECMP. If all received paths qualify as best paths, multiple paths will be installed to UFTM, up to the configured limit.

Process Additional Paths

When a neighboring router sends an update message with additional paths, the paths are decoded and extracted. Each path is identified by a unique Path-ID, which is used to track future updates for that path. The paths undergo regular path selection criteria, and only the best route is chosen and installed to Unified Forwarding Table Manager (UFTM). The key benefits include path diversity (accepting additional paths provides efficient use of multiple paths and hitless planned maintenance) and Improved network utilization (multiple paths can be used to optimize network resource utilization).

The following examples show a prefix (192.0.2.13/24) being received from a remote BGP device with three different path IDs (1, 2, and 555):

- Routes shown in the **received-route** option of the peer:

```
device# show bgp vrf default-vrf neighbor 192.0.2.2 received-routes ipv4-unicast
detail

VRF Name: default-vrf
Total number of routes: 3

Prefix: 192.0.2.13/24, Nexthop: 192.0.2.2, Path ID: 1, AS Path:
Age: 6s, Status: VALID Best-Path: Yes
Origin: IGP, Local Preference: 100, MED: -, Weight: -, Admin Distance:
Communities: -
```

```

Extended-Communities:

Prefix: 192.0.2.13/24, Nexthop: 192.0.2.2, Path ID: 2, AS Path:
Age: 6s, Status: VALID Best-Path: No
Origin: IGP, Local Preference: 100, MED: -, Weight: -, Admin Distance:
Communities:
Extended-Communities:

Prefix: 192.0.2.13/24, Nexthop: 192.0.2.2, Path ID: 555, AS Path:
Age: 65, Status: VALID Best-Path: No
Origin: IGP, Local Preference: 100, Weight: -, Admin Distance:
Communities:
Extended-Communities:
device#

```

- Routes shown in the **routes-summary** option:

```

device# show bgp vrf default-vrf routes ipv4-unicast 192.0.2.13/24

Prefix: 192.0.2.13/24, Nexthop: 192.0.2.2, Peer: 192.0.2.2, Path ID: 1, Age: 5m20s,
Status: VALID Best-Path: Yes
AS Path:
Origin: IGP, Local Preference: 100, MED: -, Weight: -, Admin Distance:
Communities:
Extended-Communities: -

Prefix: 192.0.2.13/24, Nexthop: 192.0.2.2, Peer: 192.0.2.2, Path ID: 2, AS Path: Age:
5m20s, Status: VALID Best-Path: No
Origin: IGP, Local Preference: 100, MED: -, Weight: -, Admin Distance:
Communities:
Extended-Communities:

Prefix: 192.0.2.13/24, Nexthop: 192.0.2.2, Peer: 192.0.2.2, Path ID: 555, AS Path:
Age: 5m20s, Status: VALID Best-Path: No
Origin: IGP, Local Preference: 100, MED: -, Weight: -, Admin Distance:
Communities:
Extended-Communities:
device#

```

YANG and Configuration Commands

The feature is supported through YANG models. You can enable Add-Path at the global, peer group, and peer levels.

You can display information about Add-Path via **show** commands including **show bgp vrf <vrf-name> summary <afi-safi>** and **show bgp vrf <vrf-name> neighbor <nbr-ip>**.

Add-Path provides path diversity by accepting multiple paths for the same prefix. The Path-ID uniquely identifies each path by enabling efficient tracking and management of multiple paths. Regular path selection criteria apply to choose only the best route and installed to UFTM.

For details on syntax and parameters, see the *Extreme OS ONE SR Command Reference Guide*. For details on YANG modules, see the *Extreme OS ONE SR YANG Reference Guide*.

Event Log Messages for BGP Add-Path

These log messages provide valuable information for troubleshooting and monitoring BGP Add-Path functionality. The system generates event log messages for various BGP Add-Path events, including:

1. **Receiving and decoding ADD-PATH capability:** Logs show when BGP receives and successfully decodes the ADD-PATH capability from a peer:
 - decodeCapability: Received Capability VrfName[default-vrf] Peer[13.1.1.2] CapCode[69] CapLen[4] CapValue[]
 - decodeAddPathCap: Decoded ADD-PATH capability Peer[13.1.1.2] CapLen[4] Afi[1] Safi[1] Mode[3]
2. **Receiving new path with path-id:** Logs indicate when BGP receives a new path with a valid path-id for a given prefix:
 - decodePathIDFromNlri: Path-ID extracted from BGP-Peer Peer[13.1.1.2] NlriLen[4] Path-id[1]
 - decodeIPNlri: Path-ID received for prefix VrfName[default-vrf] Peer[13.1.1.2] Prefix[? 0d0d0d] NlriLen[3] Path-id[1]

BGP Allow-Own-AS

The BGP Allow-Own-AS feature helps to manage route advertisements and prevent routing loops in complex BGP setups. Normally, BGP rejects routes containing its own Autonomous System (AS) number in the AS path to avoid loops. However, in certain scenarios, this check might need to be bypassed.

Why Allow-Own-AS?

In multi-homed networks (connected to multiple upstream ASs), a router might need to advertise routes back to a peer or accept routes with its own AS number in the path. Allowing this can prevent route discard due to standard anti-loop checks. By carefully managing Allow-Own-AS, you can optimize route advertisements and maintain network stability.

Key Points

This feature is disabled by default, which means that routers reject routes with their own AS number. When enabled, BGP accepts routes with its own AS number in the AS path.

This feature is disabled by default, which means that routers reject routes with their own AS number. When enabled, BGP accepts routes with its own AS number in the AS path.

You enable this feature at the peer group level. Enabling it triggers a route refresh message to all peers in the group. Disabling it scans the Routing Information Base In (RIBIN) and removes routes with the device AS number.

Configuring BGP Allow-Own-As

Use the **allow-own-as** command to set how many times the router's own AS number (local AS) can appear in the AS path of a BGP update from peers of this peer group before being rejected or marked as invalid.

The following example configures a BGP peer group named `group1` under a Virtual Routing and Forwarding (VRF) instance named `violet`. A BGP session within the peer group is reset when the local AS number appears in that session for the 11th time:

```
device# configure terminal
device(config)# vrf violet
device(config-vrf-violet)# router bgp
device(config-vrf-bgp)# peer-group group1
device(config-vrf-bgp-pg)# allow-own-as 10
device(config-vrf-bgp-pg)#
```

The following example displays the configuration of a VRF instance named `violet` that is running currently on the device. In this example, any BGP session in the peer group can encounter the local AS number up to 10 times before being reset

```
device# show running-config vrf violet

vrf violet
!
  router bgp
    peer-group group1
      allow-own-as 10
!
device#
```

:

BGP Local-AS-Forced

You can override the router local AS number of BGP peers to establish sessions with old BGP peers supporting only 2-byte AS numbers. By default, the local AS number override feature is disabled for the specified BGP peer group.

Configuring BGP Local-AS-Forced

Use the **local-as-forced** command to override the router's local autonomous system (AS) number with a forced 2-byte AS number to establish sessions with peers of the BGP peer group for which this command is configured.

The following example configures a BGP peer group named `group1` under a VRF instance named `violet`. This example uses the **local-as-forced** command to override the configured local ASs of the router for members of `group1` and forces them to use 100 as the AS number instead:

```
device# configure terminal
device(config)# vrf violet
device(config-vrf-violet)# router bgp
device(config-vrf-bgp)# peer-group group1
device(config-vrf-bgp-pg)# local-as-forced 100
device(config-vrf-bgp-pg)#
```

The following example displays the configuration of a VRF instance named violet that is running currently on the device. In this example, members of the group1 peer group are forced to use 100 as the AS number instead of their routers' configured local AS numbers:

```
device# show running-config vrf violet

vrf violet
!
  router bgp
    peer-group group1
      local-as-forced 100
!
device#
```

Configure BGP MD5 Authentication

MD5 authentication provides a robust security mechanism for BGP sessions, ensuring the integrity and authenticity of exchanged messages.

MD5 authentication is a crucial security feature in Border Gateway Protocol (BGP) that ensures the authenticity and integrity of BGP sessions between routers. It prevents unauthorized session initiation, protects against malicious attacks, and verifies the legitimacy of BGP peers.

Use the **auth-password** command to specify a password for MD5 authentication to be used by all members of the specified BGP peer group within a Virtual Routing and Forwarding (VRF) instance.

```
device# configure terminal
device(config)# vrf violet
device(config-vrf-violet)# router bgp
device(config-vrf-bgp)# peer-group group1
device(config-vrf-bgp-pg)# auth-password MyPassword1
device(config-vrf-bgp-pg)#
```

When two routers establish a BGP session, they exchange messages with a cryptographic hash generated using the MD5 algorithm and a shared secret key. The receiving router recalculates the hash and compares it to the received hash. If they match, the session is authenticated. Otherwise, it is rejected.

No default password is set. Manual configuration of a password is required. Session expiration or immediate termination depends on password configuration.

This feature is limited to 75 peer groups with ListenRange for dynamic groups because of kernel memory limitations.

This feature has the following key benefits and features:

- Protects against unauthorized access and tampering
- Supports both IPv4 and IPv6 peers
- Supports dynamic neighbors

- Ensures integrity and authentication, but does not encrypt BGP messages
- Performs MD5 hashing and processing in the kernel for minimal computational overhead

BGP Multiprotocol

Multiprotocol BGP feature enhances the flexibility and scalability of BGP routing.

Multiprotocol BGP (MP-BGP) extends standard BGP4 to support the following address families:

- IPv4 and IPv6 addresses
- Unicast variants as follows: address-family IPv4 unicast, address-family IPv6 unicast, and address-family L2VPN EVPN

You use MP-BGP to configure BGP routers to communicate the types of routes to exchange with peers by specifying an Address Family Identifier (AFI) and a Subsequent Address Family Identifier (SAFI).

Each AFI or SAFI can be activated or deactivated individually, allowing for flexible route exchange. MP-BGP is enabled by default and cannot be disabled. BGP routers negotiate with peers only for activated AFI or SAFI pairs.

BGP Route Refresh

You use BGP Route Refresh to configure BGP routers to request and exchange updated routing information without resetting BGP sessions. This is useful when routing policies change or peers are added/removed, allowing routers to obtain fresh routing information.

When a route policy is applied to a Routing Information Base (RIB), BGP only accepts routes that pass the filter and discards others. If the policy changes, BGP may not know which routes were previously filtered out. To resolve this, BGP sends a route refresh message to request a fresh copy of the peer's RIB. This feature streamlines routing information updates, reducing the need for manual intervention and improving network efficiency.

Key Points

This feature has the following key benefits and features:

- Route Refresh is enabled by default, with no CLI option to disable.
- The capability is negotiated per Address Family Identifier (AFI) and Subsequent Address Family Identifier (SAFI).
- Route refresh can be manually triggered using the **clear bgp vrf <vrf-name> <afi-safi> neighbor <all>** command.
- The current implementation supports only the basic Route Refresh Capability, not the advanced Route Refresh Capability that is defined in RFC-7313.

Configure EBGP Multihop: Extending BGP Reachability

EBGP Multihop offers flexibility and scalability, making it essential for large, complex networks that span multiple locations or organizations.

External Border Gateway Protocol (EBGP) sessions are established between directly connected routers. With EBGP Multihop, BGP sessions can traverse multiple routers, providing greater flexibility and scalability for large networks.

This feature does not apply to IPv6 link-local peers (which are single-hop by nature).

Use the **ebgp-multihop** command to enable external BGP multihop and optionally set the time-to-live (TTL) value of the IP header (hop count) for a specific external BGP neighbor or all external neighbors in the specified BGP peer group within a VRF instance.

```
device# configure terminal
device(config)# vrf violet
device(config-vrf-violet)# router bgp
device(config-vrf-bgp)# peer-group group1
device(config-vrf-bgp-pg)# ebgp-multihop 10
device(config-vrf-bgp-pg)# exit
device(config-vrf-bgp)# peer-group group2
device(config-vrf-bgp-pg)# ebgp-multihop
device(config-vrf-bgp-pg)#
```

Key Benefits and Considerations

This feature has the following key benefits:

- Supports BGP sessions over intermediate routers
- Improves network management and policy control
- Supports scalable and fault-tolerant network designs
- Provides alternate data paths in case of link failures

This feature has the following key considerations:

- The default TTL is 1 for eBGP peers and 64 for iBGP peers.
- EBGP Multihop overrides TTL hop count for eBGP peers.
- This feature does not apply to IPv6 link-local peers (which are single-hop by nature).

Comparison to Standard BGP

Standard BGP requires direct router connections. EBGP Multihop provides peering over multiple hops, making it ideal for expansive networks.

BGP Fast External Failover

BGP Fast External Failover accelerates BGP convergence when an external link or peer fails. This feature is particularly beneficial in environments requiring rapid routing path recovery, such as ISP networks or critical infrastructure relying on BGP.

In traditional BGP, failure detection, route withdrawal, and routing table re-computation can be time-consuming, leading to significant disruptions in data traffic. But, the BGP Fast External Failover feature provides continuous monitoring of BGP peers over a given link. Upon detecting a link failure, BGP takes immediate corrective action without waiting for traditional timeout mechanisms. This is achieved through direct detection of link failures and rapid notification and response. By using BGP Fast External Failover, networks can minimize downtime and ensure faster recovery from external link or peer failures. Multihop scenarios rely on BFD for failure detection.

This feature is only applicable to eBGP peers and is suitable for directly connected eBGP peers.

This feature is not enabled by default. Explicit configuration required.

Configuring BGP Fast External Failover

Use the **fast-external-failover** command to quickly terminate the EBGP session when a directly-connected link to the EBGP peer goes down, without waiting for the hold-down timer to expire.

The following example configures a BGP peer group named `group1` under a Virtual Routing and Forwarding (VRF) instance named `violet`. In this example, the BGP session is reset if the link to an EBGP peer goes down:

```
device# configure terminal
device(config)# vrf violet
device(config-vrf-violet)# router bgp
device(config-vrf-bgp)# peer-group group1
device(config-vrf-bgp-pg)# fast-external-failover
device(config-vrf-bgp-pg)#
```

The following example displays the configuration of a VRF instance named `violet` that is running currently on the device. In this example, the BGP session is reset if the link to an EBGP peer in a peer group named `group1` is lost:

```
device# show running-config vrf violet
vrf violet
!
  router bgp
    peer-group group1
      allow-own-as 10
      fast-external-failover
!
device#
```

BGP IPv6

The Border Gateway Protocol (BGP) IPv6 feature adds IPv6 support to BGP routing, enabling the exchange of routing information for IPv6 networks alongside traditional IPv4 networks. This feature includes:

- IPv6 Unicast Support: BGP can exchange IPv6 unicast routes, forwarding IPv6 packets across networks.
- IPv6 Address Family Configuration: Commands specific to IPv6 are configured independently of IPv4, providing flexibility in managing routing for different traffic types.
- Route Propagation and Filtering: IPv6 routes can be propagated across Autonomous Systems (ASs) with configurable policies for filtering or modifying route advertisements.
- Address Family Independent BGP Peering: IPv6 peering can be configured separately from IPv4, allowing organizations to maintain distinct peering for each address family.

IPv4 peers cannot carry IPv6 routes, and IPv6 peers cannot carry IPv4 routes. IPv6 Unicast operates independently of IPv4 Unicast.

An IPv6 address family must be explicitly activated.

For details on command syntax and parameters for configuring address family, see the *Extreme OS ONE SR Command Reference Guide*.

BGP IPv6 Prefix Advertisement over IPv4 BGP Peers

This document describes how to configure and manage IPv6 prefix advertisement over existing IPv4 BGP sessions using Extreme OS ONE. This feature exchanges IPv6 routing information through your current IPv4 BGP infrastructure without establishing separate IPv6 BGP sessions.

This feature provides a powerful tool for IPv6 deployment while maintaining your existing IPv4 BGP infrastructure. Use the following configuration procedures and best practices to ensure successful implementation in your network environment.

Overview of BGP IPv6 Prefix Advertisement over IPv4 BGP Peers

You can advertise IPv6 prefixes over your existing IPv4 BGP peering sessions. This capability uses Multiprotocol Extensions for BGP (MP-BGP) to carry IPv6 routing information within IPv4 TCP connections.

The system encapsulates IPv6 routing information within MP-BGP update messages and transmits them over established IPv4 BGP sessions. Both routers must support and negotiate the IPv6 capability during the BGP session establishment process.

Key Components

The BGP IPv6 Prefix Advertisement over IPv4 BGP Peers uses existing IPv4 BGP sessions as transport and maintains complete IPv6 routing attributes (next-hop, AS_PATH, communities, and Multi-Exit Discriminator (MED)). The feature implements RFC 2858 (Multiprotocol Extensions for BGP4) and supports RFC 2545 for IPv6 routing information.

Benefits

The BGP IPv6 Prefix Advertisement over IPv4 BGP Peers feature has the following primary benefits.

Simplified Network Management

- Reduces the number of BGP sessions to maintain
- Eliminates duplicate session management overhead
- Uses a single IPv4 session for both IPv4 and IPv6 routing

Streamlined IPv6 Migration

The BGP IPv6 Prefix Advertisement over IPv4 BGP Peers feature streamlines IPv6 migration in the following ways:

- Transitions to IPv6 gradually while maintaining existing IPv4 infrastructure
- Avoids complex dual-stack BGP configurations
- Reduces resource consumption on network devices

Operational Efficiency

The BGP IPv6 Prefix Advertisement over IPv4 BGP Peers feature increases operational efficiency in the following ways:

- Lowers configuration complexity
- Has fewer sessions to monitor and troubleshoot
- Provides consolidated routing policy management

Limitations

The BGP IPv6 Prefix Advertisement over IPv4 BGP Peers feature does not support configuring IPv4-mapped IPv6 addresses on Layer 3 interfaces. Also, you must use route policies to ensure next-hop reachability for native IPv6 addresses.

Session Behavior

IPv4 BGP sessions are established when both IPv4 and IPv6 address families are activated at the router BGP level and at the peer group level. Both IPv4 as well as IPv6 prefixes could be advertised over a single IPv4 BGP session.

Resource Impact

Memory usage increases proportionally with the IPv6 routing table size. Standard BGP scaling limits apply to combined IPv4 and IPv6 operations. No additional performance or scalability challenges are expected.

Next-Hop Handling

Following is the order of priority in which the IPv6 next hop is picked up for IPv6 routes advertised to IPv4 BGP peers:

1. Route policy with **set-next-hop** applied for peer-group: This requires a route policy to be configured with **set-next-hop** set to any IPv6 address that is configured on the BGP peering interface and applying this route policy as an outbound/export policy for an IPv4 peer.

This configuration overrides the default behavior, which picks the lowest IPv6 address of the IPv4 BGP session's source interface as the next hop of the IPv6 routes advertised to IPv4 BGP peers.

2. Lowest IPv6 address of the IPv4 BGP session's source interface is picked up as the next hop of the IPv6 routes advertised to IPv4 BGP peers if **route-policy** (with **set-next-hop**) is not applied for the IPv4 peer.
3. IPv4-mapped IPv6 address: If no IPv6 address is configured on the IPv4 BGP session's source interface, the IPv6 routes are advertised to IPv4 peers with the next hop in IPv4-mapped-IPv6 format `::ffff:a.b.c.d`, where `a.b.c.d` is the IPv4 address of the BGP source interface.

Next-Hop Reachability Considerations

You must consider the following issues for Next-Hop Reachability of IPv4-mapped IPv6 addresses:

- Next-hop reachability depends on your IPv4 routing table.
- Standard IPv4 forwarding handles packet delivery.

You must consider the following issues for Next-Hop Reachability of native IPv6 addresses:

- Configure IPv6 interfaces with matching addresses.
- Ensure that the IPv6 routing table contains reachable paths.
- Use route policies to set appropriate next-hop values.

Prerequisites

The BGP IPv6 Prefix Advertisement over IPv4 BGP Peers feature has the following prerequisites.

Network Prerequisites

Make sure that you have prepared your network in the following ways:

- Establish existing IPv4 BGP peering relationships
- Ensure that both BGP peers support multiprotocol extensions for BGP
- Ensure that IPv6 connectivity is available for next-hop reachability (when using native IPv6 next-hops)

BGP Peer Prerequisites

Remote BGP speakers must support MP-BGP IPv6 capability. Capability negotiation must succeed during BGP session establishment.

Enable the BGP IPv6 Prefix Advertisement over IPv4 BGP Peers Feature

You enable the BGP IPv6 Prefix Advertisement over IPv4 BGP Peers feature at the per peer-group level. Configuring this feature via the CLI consists of the following basic procedures:

- Configuring the IPv6 address family
- Configuring the peer group
- Applying the configuration

The following example shows how to enable the BGP IPv6 Prefix Advertisement over IPv4 BGP Peers feature:

```
device(config-vrf-bgp-pg-ipv6u)# do show running-config vrf vrl

vrf vrl
  router-id 192.0.2.1
  member ve 2-9
  router bgp
    local-as 100
    router-id 192.0.2.1

    address-family ipv4 unicast
      activate
    !
    address-family ipv6 unicast
      activate
    !

  peer-group pgV6OverV4
    remote-as 200
    address-family ipv4 unicast
      activate
    !
    address-family ipv6 unicast
      export-policy mpbgpSetNH
      activate
```

```

!
 neighbor 192.0.2.2
!
!
!
device(config-vrf-bgp-pg-ipv6u)#

```

Verification and Monitoring

For the BGP IPv6 Prefix Advertisement over IPv4 BGP Peers feature, the following sections describe the following tasks:

- Check that both peers have negotiated IPv6 capability
- Display IPv6 routes learned through the IPv4 BGP session
- Confirm that the BGP session carries both address families

Verify BGP Capability Negotiation

To check that both peers have negotiated IPv6 capability, enter the following command:

```
show bgp vrf vrf-name neighbor all
```

For example:

```

device# show bgp vrf vr1 neighbor all

Peer: 192.0.2.3, Remote Port: 179, Peer-AS: 200
Localhost: 192.0.2.4, Local Port: 49882, Local-AS: 100, Local-AS-Forced: -
Peer Router ID: 192.0.2.2, Local Router ID: 192.0.2.1, VRF: vr1
Route Reflector Client: No, Cluster-ID: -
Fast External Failover: false
State: Established, Uptime: 5m17s, Dynamic Peer: false, Peer Group: pgV6OverV4

Last Notification Time :
Last Connection Reset Reason:
Send Community: No, Send Extended Community: No

Capabilities      Negotiated   Advertised   Received
=====
Route-Refresh     true         true         true
AS-4Byte          true         true         true
Cisco-RR          true         true         true
MPBGP             true         true         true

MPBGP:
=====
Advertised: IPv4Ucast,IPv6Ucast
Received : IPv4Ucast,IPv6Ucast
Negotiated: IPv4Ucast,IPv6Ucast

Timers            Interval(Sec)  Method        Remaining(Sec)
=====
Connect Retry     31             Default       -
Hold Time         180           Negotiated    163
Keepalive Timer   60            Default       43
Start Timer       5             System        -

```

```

Update Interval      0          Default      -
device#

```

In the command output, verify that the MP-BGP section shows the following data:

- Advertised: IPv4Ucast,IPv6Ucast
- Received: IPv4Ucast,IPv6Ucast
- Negotiated: IPv4Ucast,IPv6Ucast

Monitor IPv6 Routes

To display the IPv6 routes learned through your IPv4 BGP session for the BGP IPv6 Prefix Advertisement over IPv4 BGP Peers feature, enter the following command:

```
show bgp vrf vrf-name routes ipv6-unicast
```

For example:

```

device# show bgp vrf default-vrf routes ipv6-unicast

BGP routing table information for VRF default-vrf
Status: *-valid, >-best, S-stale
Path type: i-internal, e-external, l-local, r-redist, m-multipath, a-additional,
           p-primary, s-secondary
Origin codes: I - IGP, E - EGP, ? - incomplete

IPv6 Routes
-----
Total number of routes: 1

Flags      Prefix                               Nexthop                               Peer
=====
2001:db8:0:2::34/128  ::ffff:192.0.2.2                      192.0.2.2
2001:db8:0:2::34/128  ::ffff:192.0.2.10                     192.0.2.10
2001:db8:0:2::34/128  ::ffff:192.0.2.4                      192.0.2.4
2001:db8:0:2::34/128  ::ffff:192.0.2.6                      192.0.2.6
2001:db8:0:2::34/128  ::ffff:192.0.2.8                      192.0.2.8
2001:db8:0:2::34/128  ::ffff:192.0.2.0                      192.0.2.0
device#

```

This output shows the following details:

- IPv6 prefixes (such as 2001:db8:0:2::34/128)
- Next-hop addresses (such as ::ffff:192.0.2.2)
- Peer information (such as 192.0.2.2)

Verify Session Status

To confirm that your BGP session carries both address families for the BGP IPv6 Prefix Advertisement over IPv4 BGP Peers feature, enter the following command:

```
show bgp vrf vrf-name summary ipv6-unicast
```

For example:

```
device# show bgp vrf vr1 summary ipv6-unicast
```

```

VRF Name : vr1
Local AS: 6500, Router ID: 2001:db8:25:25:25:25
Confederation Identifier: not configured
Confederation Peers: not configured
Graceful Restart: Disabled

IPv6 Unicast Summary Information
-----
Graceful Restart: Disabled
Prefix Independent Convergence: Disabled
Nexthop address resolution - Recursion: Disabled, Default-Route: Disabled
Number of Routes :0 (Paths: 0)
Number of Peer(s) Configured : 125, Up : 125

D: Dynamically created based on a listen range command, Dynamically created neighbors: 0
C: Route Reflector Client

Peer IP      Peer AS  Local IP          State      Health  UpTime      RIB-IN  RIB-OUT
Flags Peer Group
=====
=====
192.0.2.2 6501    2001:db8:1:1:84::1  Established -    1h19m12s  0        0
- pg_ipv6_1
192.0.2.3 6501    2001:db8:1:1:99::1  Established -    1h19m12s  0        0
- pg_ipv6_1
192.0.2.4 6501    2001:db8:1:1:ad::1  Established -    1h19m11s  0        0
- pg_ipv6_1
192.0.2.5 6501    2001:db8:1:1:d9::1  Established -    1h19m10s  0        0
- pg_ipv6_1
192.0.2.6 6501    2001:db8:1:1:df::1  Established -    1h19m10s  0        0
- pg_ipv6_1
192.0.2.7 6501    2001:db8:1:1:b7::1  Established -    1h19m11s  0        0
- pg_ipv6_1
192.0.2.8 6501    2001:db8:1:1:ed::1  Established -    1h19m10s  0        0
- pg_ipv6_1
192.0.2.9 6501    2001:db8:1:1:97::1  Established -    1h19m12s  0        0
- pg_ipv6_1
192.0.2.10 6501    2001:db8:1:1:dc::1  Established -    1h19m10s  0        0
- pg_ipv6_1
192.0.2.11 6501    2001:db8:1:1:eb::1  Established -    1h19m10s  0        0
- pg_ipv6_1
192.0.2.12 6501    2001:db8:1:1:7f::1  Established -    1h19m13s  0        0
- pg_ipv6_1
192.0.2.13 6501    2001:db8:1:1:a9::1  Established -    1h19m11s  0        0
- pg_ipv6_1
192.0.2.14 6501    2001:db8:1:1:ac::1  Established -    1h19m11s  0        0
- pg_ipv6_1
192.0.2.15 6501    2001:db8:1:1:d7::1  Established -    1h19m10s  0        0
- pg_ipv6_1
192.0.2.16 6501    2001:db8:1:1:c8::1  Established -    1h19m11s  0        0
- pg_ipv6_1
192.0.2.17 6501    2001:db8:1:1:d6::1  Established -    1h19m10s  0        0
- pg_ipv6_1
192.0.2.18 6501    2001:db8:1:1:a5::1  Established -    1h19m12s  0        0
- pg_ipv6_1
device#

```

This command shows the following details:

- Session state information
- Number of IPv6 prefixes received (RIB-IN) and advertised (RIB-OUT)
- Session uptime and statistics

BGP Monitoring with Bidirectional Forwarding Detection (BFD)

BFD support for BGP provides fast detection of link failures between BGP peers. By default, BFD for BGP is disabled. When enabled, BFD notifies BGP of any faults, allowing for quicker convergence. You use the **enable-bfd** command to enable BFD for a specified BGP neighbor or all neighbors in the specified BGP peer group within a VRF instance.

This feature has the following key functionalities:

- Supports single-hop and multihop iBGP and eBGP sessions with IPv4 or IPv6 neighbors
- Works across default and non-default VRF instances
- Uses behavior consistent for iBGP and eBGP, regardless of session type or neighbor IP version

Configuration Considerations

- Registration is global across all VRFs (BFD sessions require configuration on both neighbors).
- Each neighbor can have custom settings for transmit interval, receive interval, and detection multiplier.
- Peer group or global settings are inherited if not configured.
- Enabling BFD is controlled at the peer group level. All session parameters are inherited from the peer group level.
- BFD is not enabled by default and requires explicit configuration.
- The default timers are 300ms (Rx and Tx) with a multiplier of 3.
- BGP monitoring with BFD is supported for IPv4 and IPv6 peers, including dynamic peers.

Configuring BGP Monitoring with BFD

The following example configures a BGP peer group named `group1` under a VRF instance named `violet`. The **enable-bfd** command is used in BGP peer group configuration mode and therefore enables BFD for all neighbors in the peer group:

```
device# configure terminal
device(config)# vrf violet
device(config-vrf-violet)# router bgp
device(config-vrf-bgp)# peer-group group1
device(config-vrf-bgp-pg)# enable-bfd profile profile1
device(config-vrf-bgp-pg)#
```

The following example displays the configuration of a VRF instance named `violet` that is running currently on the device. This example configures a BGP peer group named `group1` and enables BFD for all neighbors in the peer group:

```
device # show running-config vrf violet

vrf violet
!
```

```
router bgp
  peer-group group1
    enable-bfd profile profile1
!
device#
```

The following example configures a BGP peer group named `group1` under a VRF instance named `violet`. The **enable-bfd** command enables BFD only for the 192.0.2.0 neighbor within the peer group:

```
device# configure terminal
device(config)# vrf violet
device(config-vrf-violet)# router bgp
device(config-vrf-bgp)# peer-group group1
device(config-vrf-bgp-pg)# neighbor 192.0.2.0
device(config-vrf-bgp-pg-neighbor)# enable-bfd profile profile1
device(config-vrf-bgp-pg-neighbor)#
```

BGP Protocol Event Monitoring and Notification

The BGP Protocol Event Monitoring and Notification feature automates alerts about issues such as policy misconfigurations and route flaps rather than requiring manual CLI checks, improving efficiency and network stability. Key events monitored include BGP IPv4 and IPv6 connection state transitions (one of the pre-Established to Established state) and Established to one of the pre-Established state).

Supported Functionalities

You can configure BGP Protocol Event Monitoring and Notification to send the following types of data:

- gNMI notifications as part of BGP Finite State Machine (FSM) events and BGP session UP/DOWN events
- RAS trace logs as part of BGP UP/DOWN events
- SNMP traps as part of BGP FSM events for Enterprise MIB and Standard MIB

BGP Enterprise and Standard MIB Notifications

BGP reports significant events to the message bus when a BGP session changes state to Established or experiences backward transitions. These BGP traps contain session information within their payload/Varbind. The BGP Enterprise and Standard MIB define specific trap OID and Varbind lists for this purpose.

BGP standard MIB notifications are sent for the peers of IPv4 types. [Table 5](#) lists the BGP standard MIB notifications and varbinds.

Table 5: BGP standard MIB notifications

Trap name and OID	Varbinds	Description
bgpEstablishedNotification 1.3.6.1.2.1.15.0.1	bgpPeerRemoteAddr bgpPeerLastError bgpPeerState	The bgpEstablishedNotification event is generated when the BGP FSM enters the established state.
bgpBackwardTransNotification 1.3.6.1.2.1.15.0.2	bgpPeerRemoteAddr, bgpPeerLastError, bgpPeerState	The bgpBackwardTransNotification event is generated when the BGP FSM moves from a higher numbered state to a lower numbered state.

The BGP enterprise MIB notifications are sent for the peers of IPv6 types. [Table 6](#) lists the BGP enterprise MIB notifications and varbinds.

Table 6: BGP enterprise MIB notifications

Trap name and OID	Varbinds	Description
extremeBGP4V2EstablishedNotification 1.3.6.1.4.1.1916.1.51.0.1	extremeBgp4V2PeerState extremeBgp4V2PeerLocalPort extremeBgp4V2PeerRemotePort extremeBgp4V2PeerRemoteAddr	The extremeBGP4V2EstablishedNotification event is generated when the BGP FSM enters the established state.
extremeBGP4V2BackwardTransitionNotification 1.3.6.1.4.1.1916.1.51.0.2	extremeBgp4V2PeerState extremeBgp4V2PeerLocalPort extremeBgp4V2PeerRemotePort extremeBgp4V2PeerLastErrorCodeReceived, extremeBgp4V2PeerLastErrorSubCodeReceived, extremeBgp4V2PeerLastErrorReceivedText extremeBgp4V2PeerRemoteAddr	The extremeBGP4V2BackwardTransitionNotification event is generated when the BGP FSM moves from a higher numbered state to a lower numbered state.

Following is an example of a BGP SNMP trap message:

```
2025-02-17 09:49:36 <UNKNOWN> [UDP: [10.32.100.182]:53908->[10.37.32.26]:200]:
iso.3.6.1.2.1.1.3.0 = Timeticks: (25057400) 2 days, 21:36:14.00 iso.3.6.1.6.3.1.1.4.1.0 =
OID: iso.3.6.1.4.1.1916.1.51.0.2 iso.3.6.1.4.1.1916.1.51.1.2.1.13 = STRING: "Idle"
iso.3.6.1.4.1.1916.1.51.1.2.1.5 = STRING: "1000::1" iso.3.6.1.4.1.1916.1.51.1.3.1.1
= Counter32: 6 iso.3.6.1.4.1.1916.1.51.1.3.1.2 = Counter32: 6
iso.3.6.1.4.1.1916.1.51.1.2.1.6 = Counter32: 179 iso.3.6.1.4.1.1916.1.51.1.2.1.9
```

```
= Counter32: 38292      iso.3.6.1.4.1.1916.1.51.1.3.1.4 = STRING: "CEASE
OTHER_CONFIG_CHANGE"
```

gNMI Notifications

BGP neighbor configuration or state changes are published to the gNMI path `network-instances/network-instance[name=]/protocols/protocol[identifier=BGP][name=bgp]/bgp/neighbors/neighbor[neighbor-address=]/`

```
+--rw network-instances
  +--rw network-instance* [name]
    . . .
    +--rw protocols
      | +--rw protocol* [identifier name]
      | +--rw bgp
      . . .
      | +--rw neighbors
      | | +--rw neighbor* [neighbor-address]
      | | +({)rw neighbor-address(-) > ../config/neighbor-address
      . . .
      | | +--ro state                                         oc-inet:as-number
      | | | +--ro session-state?
      enumeration
      | | | +--ro last-established?                             oc-
      types:timeticks64
      | | | +--ro established-transitions?                       oc-
      yang:counter64
      | | | +--ro supported-capabilities*
      identityref
      | | | +--ro messages
      | | | | +--ro sent
      | | | | | +--ro UPDATE?                                   uint64
      | | | | | +--ro NOTIFICATION?                           uint64
      | | | | | +--ro last-notification-time?                   oc-
      types:timeticks64
      | | | | | +--ro last-notification-error-code?             identityref
      | | | | | +--ro last-notification-error-subcode?          identityref
      | | | | +--ro received
      | | | | | +--ro UPDATE?                                   uint64
      | | | | | +--ro NOTIFICATION?                             uint64
      | | | | | +--ro last-notification-time?                   oc-
      types:timeticks64
      | | | | | +--ro last-notification-error-code?             identityref
      | | | | | +--ro last-notification-error-subcode?          identityref
```

RASlogs

The following are Session UP/Down RASlogs:

```
2025-01-16 11:04:36.7728 bgp[15]: {"Level":"info","LogID":9008,"Topic":2,"VRF":"default-vrf","Neighbor":"192.x.x.x","Reason":"ADMIN-DOWN","Msg":"Session DOWN"}
2025-01-16 11:04:36.7729 bgp[15]: {"Level":"info","LogID":9008,"Topic":2,"VRF":"default-vrf","Neighbor":"10.x.x.x","Reason":"ADMIN-DOWN","Msg":"Session DOWN"}
2025-01-16 11:06:29.1857 bgp[15]: {"Level":"info","LogID":9008,"Topic":2,"VRF":"default-vrf","Neighbor":"10.x.x.x","Msg":"Session UP"}
2025-01-16 11:06:31.8469 bgp[15]: {"Level":"info","LogID":9008,"Topic":2,"VRF":"default-vrf","Neighbor":"10.x.x.x","Msg":"Session UP"}
```

Configure BGP Address Families

BGP supports multiple address families to cater to diverse network types and applications. Each address family specifies the type of IP address or data structure BGP will handle. The currently supported address families are:

1. IPv4 Unicast: BGP routes IPv4 addresses (the traditional and most commonly used address family)
2. IPv6 Unicast: BGP exchanges routes for IPv6 addresses
3. EVPN (Ethernet VPN): Extends BGP to carry Ethernet frames and IP routes as a modern service for multi-tenant Layer 2 and Layer 3 Ethernet services

Each BGP instance can support one or more address families (except EVPN, which is available only in the default instance). Address families operate independently within an instance with no correlation between instances.

Each address family must be activated individually before it becomes operational. Features can be enabled under specific address families.

Memory allocation occurs only when an address family is activated, optimizing memory utilization.

You can access the address-family IPv4 or IPv6 unicast configuration level from global configuration mode.

```
device# configure terminal
device(config)# vrf violet
device(config-vrf-violet)# router bgp
device(config-vrf-bgp)# address-family ipv4 unicast
device(config-vrf-bgp-ipv4u)# activate
device(config-vrf-bgp-ipv4u)# exit
device(config-vrf-bgp)# address-family ipv6 unicast
device(config-vrf-bgp-ipv6u)# activate
device(config-vrf-bgp-ipv6u)#
```

BGP4 Peer Groups

Peer groups simplify BGP configuration by grouping multiple peers with shared settings. Instead of configuring each peer individually, you define common settings once and apply them to multiple peers.

You can use the **peer-group** command to configure a BGP peer group within a Virtual Routing and Forwarding (VRF) instance and enter BGP peer group configuration mode. No default peer group exists. Each peer group must be manually configured.

You can configure BGP peers only as peer group members (not as standalone or independent peers). Each peer group requires the same capability negotiation and address family for all peers.

You can associate BGP neighbors with a BGP4 peer group. For details on syntax and parameters, see the *Extreme OS ONE SR Command Reference Guide*.

Creating multiple peer groups increases the number of RIBOUTs, which impacts memory consumption.

How Peer Groups Work

You configure a peer group by following two main procedures:

1. Define a peer group with common parameters. For example, remote-as, authentication password
2. Assign individual BGP peers to the group, eliminating the need for separate configurations

Key Benefits

Using BGP4 peer groups has the following main benefits:

- **Simplified Maintenance:** When you edit the peer group, changes are reflected across all associated peers.
- **Optimization of Updates:** Peers in a group share the same update, reducing the load by sending a single update to all members.
- **Shared Configuration:** Parameters such as timers, policies, and authentication can be shared across multiple neighbors.

Configure a BGP4 Peer Group

A BGP4 peer group is a collection of BGP neighbors that have the same attributes, parameters and address families.

The following sample output shows the configuration of a VRF named red that contains two peer groups:

```
device(config-vrf-bgp-pg-ipv4u)# do show running-config vrf red

vrf red
 member   ve 2,8192
 table-connections
  src-protocol connected dst-protocol bgp address-family ipv4
  src-protocol connected dst-protocol bgp address-family ipv6
 !
 router bgp
  local-as 4200000001
  router-id 192.0.2.171
  route-distinguisher 192.0.2.171:1
  as-notation as-plain

  address-family ipv4 unicast
   use-multiple-paths ibgp maximum-paths 8
   use-multiple-paths ebgp maximum-paths 8
  !

  address-family ipv6 unicast
   use-multiple-paths ibgp maximum-paths 8
   use-multiple-paths ebgp maximum-paths 8
  !

 instance-type evpn
  nve fs
  l3vni 8192
  address-family ipv4 unicast
   route-target export 101:101
   route-target import 101:101
```

```
!
  address-family ipv6 unicast
    route-target export 101:101
    route-target import 101:101
  !
!
!
peer-group pg1
  remote-as 651000
  neighbor 192.0.2.1
  enable-bfd profile profile_100_100_3
  update-source 192.0.2.10
  address-family ipv4 unicast
    nexthop-self
    activate
  !
!
peer-group pg2
  remote-as 651000
  neighbor 192.0.2.2
  enable-bfd profile profile_100_100_3
  update-source 2001:db8::ff
  address-family ipv4 unicast
    activate
  !
!
!
device#
```

BGP Four-Byte AS Number

BGP supports RFC 4893, which extends AS numbers to four bytes, allowing a much larger range of 0 to 4,294,967,295. This feature is enabled by default and cannot be disabled. Local-AS configurations support four-byte AS numbers, including two-byte AS numbers. Remote AS numbers always support four-byte ranges, although two-byte AS numbers can be configured.

AS Number Format

Four-byte AS numbers are represented in a two-part format:

- High-order 2 bytes (0 to 65,535)
- Low-order 2 bytes (0 to 65,535)

You can control the AS number format using the **as-notation** option at the instance level, with the following three available formats:

- as-dot (default): Displays 4-byte AS numbers in dot notation and 2-byte AS numbers in decimal
- as-dot-plus: Displays all AS numbers in dot notation
- as-plain: Displays all AS numbers in decimal

BGP supports interaction with both four-byte AS capable and two-byte AS only capable routers. If a route policy sets an AS number that exceeds the capability of the router, it will be ignored.

BGP Multi-VRF

You use BGP Multi-VRF to set up the Border Gateway Protocol (BGP) to operate with multiple Virtual Routing and Forwarding (VRF) instances on a single router. This means that BGP can maintain separate routing tables for different network environments to enable each VRF to exchange routing information independently. This adds flexible and scalable network design, but also requires careful management to avoid potential issues.

The BGP multi-VRF feature has the following key functionalities:

- **Multi-Instance Capability:** BGP can advertise routes into multiple VRFs, ensuring isolated routing information exchange.
- **Implementation:** A single BGP process internally manages multiple VRF instances, with bifurcation within the process.
- **Enabled by Default:** This feature is always enabled and cannot be disabled.
- **Single Process:** One process serves all VRF instances.
- **Per-VRF Instance:** Each VRF has its own BGP instance, configurable using the **router bgp** command.
- **Instance-Specific Configuration:** Each VRF instance has its own routing configuration, including router ID, AS number, peers, and routing tables.
- **Shared Routing Policies:** Routing policies are not VRF-aware and are shared across all VRFs.
- **Resource Sharing:** A single memory space and CPU processing are shared among all instances, which can lead to the following issues:
 - **Resource contention:** One instance can consume significant resources, impacting others.
 - **Single point of failure:** A single instance failure can affect the entire BGP setup.

BGP Router-ID

The BGP router-ID is a unique 4-octet unsigned non-zero integer that identifies the sender of BGP messages within an Autonomous System (AS). It's typically set to an IP address assigned to the BGP speaker and remains the same across all local interfaces and BGP peers.

Use the **router-id <ipv4-address>** command to set the router ID for BGP. This AS number is called the BGP router ID, and it is one per router BGP instance. For details on syntax and parameters, see the *Extreme OS ONE SR Command Reference Guide*.

- **Dual Router-IDs:** Two router-IDs exist in the configuration: One at the VRF level and another at the BGP-global level.

- **Default Behavior:** If the BGP-global level router-ID isn't configured, it inherits the VRF-level router-ID.
- **Configuration Changes:** When the BGP-global level router-ID is deleted, it falls back to the VRF-level router-ID (if configured). If no VRF-level router-ID exists, the router-ID path is removed from the SDB.

A BGP router-id is set only if explicitly configured and if not configured, the BGP router-id remains unset. Configuration of the VRF-level router-ID is not supported.

Configure BGP4 Route Reflection

BGP Route Reflection (RR) provides efficient routing information exchange within an Autonomous System (AS) without requiring direct peer-to-peer relationships between all routers. This enhances scalability in large networks.

In traditional IBGP networks, every router must establish a direct session with every other router, leading to complexity and management issues in large environments. But, a Route Reflector acts as a central point for routing information, simplifying IBGP design. Routers establish BGP sessions with one or more route reflectors, which propagate routes to the rest of the network.

When a route reflector receives a route from a client, it reflects the route to other clients, eliminating the need for a full mesh. The route reflector won't send the route back to the client that originated it.

The following are the key components of BGP route reflection:

- **Route Reflector (RR):** Redistributes BGP routes to other IBGP peers
- **Client Routers:** Form IBGP sessions with a route reflector
- **Non-Client Routers:** Participate in BGP without being part of a route reflector client group

The default Cluster ID is the Router ID, which can be overridden. The originator ID is always the router ID of the peer and cannot be overridden.

Feature and peer configuration require manual setup.

BGP4 Route Reflection does not support Optimal Route Reflection (RFC 9107).

Configure a Cluster ID for a BGP4 Route Reflector

When you have multiple route reflectors, you change the cluster ID so that all route reflectors belong to the same cluster.

1. Access global configuration mode.

```
device# configure terminal
```

2. Access VRF BGP peer group configuration mode (config-vrf-bgp-pg) and configure BGP peer group (group1) under a VRF instance named violet. The group1 group is assigned a cluster ID (10) in integer format.

```
device# configure terminal
device(config)# vrf violet
device(config-vrf-violet)# router bgp
```

```
device(config-vrf-bgp)# peer-group group1
device(config-vrf-bgp-pg)# cluster-id 10
device(config-vrf-bgp-pg)# exit
```

Configure a BGP4 Route Reflector Client

You configure a BGP peer as a route-reflector client from the device that is the route reflector.

1. Access global configuration mode.

```
device# configure terminal
```

2. Access BGP configuration mode.

```
device(config)# router bgp
```

3. Access the VRF BGP peer group configuration (config-vrf-bgp-pg) mode. Specify the peer group to be the route-reflector client.

```
ddevice# configure terminal
device(config)# vrf violet
device(config-vrf-violet)# router bgp
device(config-vrf-bgp)# peer-group group1
device(config-vrf-bgp-pg)# route-reflector-client
device(config-vrf-bgp-pg)#
```

Configure BGP Prefix Independent Convergence

In large-scale networks with thousands of BGP peers exchanging millions of routes, many routes are reachable via multiple next hops. When network topology changes, BGP recalculates the best routes for affected prefixes, which can take significant time and cause data traffic to be black-holed. To achieve faster data plane convergence and reduce the impact of network topology changes on traffic forwarding, BGP Prefix Independent Convergence (PIC) is used.

BGP PIC is supported on the Extreme 8730 platform.

BGP PIC is disabled by default.

Functional overview

BGP PIC is a feature designed to reduce data plane convergence time in large-scale networks. When enabled, BGP installs both the best path and a secondary path to a destination, allowing for fast failover in case of a failure. You can enable or disable PIC at the VRF level for IPv4 or IPv6 unicast.

BGP PIC supports IPv4 and IPv6 address families. You enable BGP PIC at the global AFI-SAFI level.

BGP PIC is supported for all VRFs. It is not supported for Layer 3 VPN, EVPN, or IP over MPLS (IPoMPLS).

Benefits

BGP PIC has the following key benefits:

- **Faster convergence time:** BGP PIC provides faster data plane convergence in case of link or node failures in the core network or edge network, reducing the time it takes to restore traffic after a failure.
- **Prefix-independent convergence:** Convergence time is no longer proportional to the number of prefixes, ensuring faster recovery.
- **Secondary path installation:** With BGP PIC enabled, BGP also installs a secondary path to the destination to improve network resilience.
- **Fast failover:** When a failure is detected, BGP switches to the secondary path, reducing traffic loss.
- **Best path selection:** BGP selects the best path to a destination and downloads it to Unified Forwarding Table Manager (UFTM).
- **Less traffic loss:** By using a backup path, traffic loss is minimized until BGP updates the next hop.
- **OptiScale:** BGP PIC is compatible with OptiScale profiles.

BGP PIC Functional Scenarios

BGP PIC functionality varies based on the location and type of network failure.

BGP PIC provides fast convergence in case of network failures. It uses two main scenarios.

BGP PIC Core Network Failure

Figure 8 illustrates a BGP PIC core network failure.

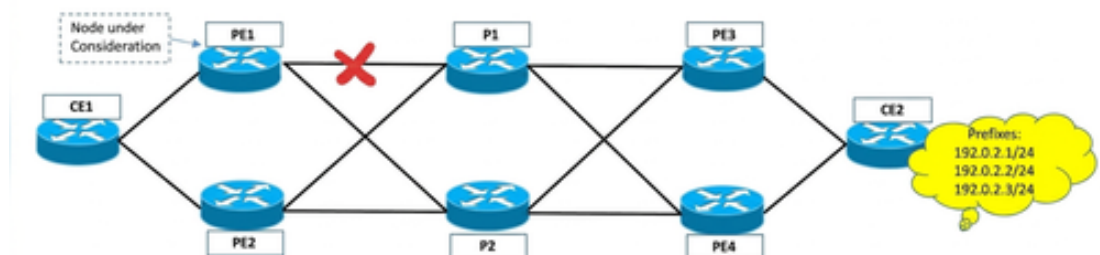

Figure 8: BGP PIC core node failure

In the scenario in Figure 8, PE1 has two paths to CE2 prefixes: one via PE3 and another via PE4. With BGP PIC enabled, PE1 selects a primary path (via PE3) and a secondary path (via PE4). The primary next hop PE3 is reachable via two paths: PE1-P1-PE3 and PE1-P2-PE3. When the link between PE1 and P1 goes down, you must use static routes or recursive or alternative BGP routes. Because the BGP next hop did not change, recovery time is based on IGP convergence.

BGP PIC Edge Network Failure

Figure 9 illustrates a BGP PIC edge network failure.

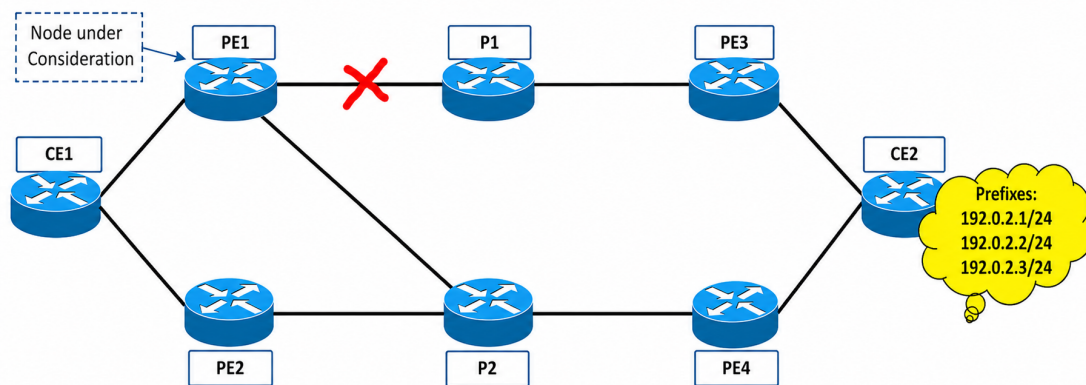

Figure 9: BGP PIC edge network failure

In the scenario in [Figure 9](#), PE1 has two paths to CE2 prefixes: one via PE3 and another via PE4. With BGP PIC enabled, PE1 selects a primary path (via PE3) and a secondary path (via PE4). When the link between PE1 and P1 goes down, UFTM detects the IGP path failure and fails over to the secondary next hop PE4 reachable via IGP path P2. The prefix routes from CE2 will be updated to point to P2, and recovery time will be based on IGP convergence.

BGP PIC Edge Node Failure

[Figure 10](#) illustrates a BGP PIC edge node failure and the behavior of the route tables.

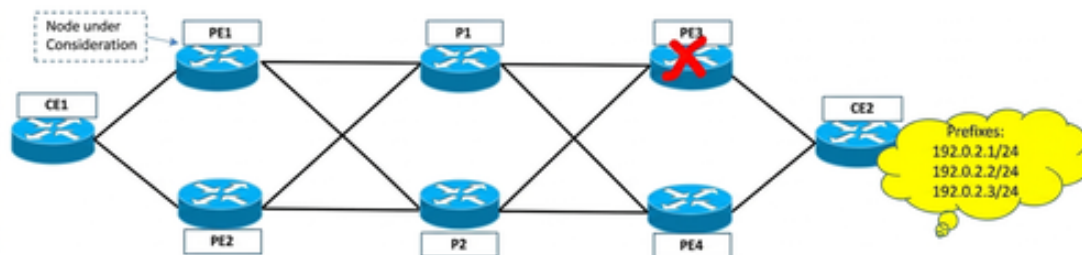

Figure 10: BGP PIC edge node failure

In the scenario in [Figure 10](#), when PE3 fails or the BGP session between PE1 and PE3 fails, BGP notifies UFTM with a NextHopDown event. UFTM resolves the secondary BGP next hop PE4 to IGP next hop and updates the next hop ID to point to PE4. Traffic will failover to the PE4 next hop, ensuring fast convergence.

Key Benefits

BGP PIC provides fast convergence in case of network failures. Recovery time is based on IGP convergence, reducing the time it takes to restore traffic.

BGP PIC Configuration Considerations

BGP graceful restart must be configured for PIC high availability (HA) to work. As a best practice, use the **profile route maximum-paths** configuration command to reduce the default ECMP value from 64 to either 8 or 16.

BGP and BFD Session Down Event

BGP/BFD session down events will signal link failures, which cause BGP to withdraw routes rapidly for faster convergence.

BGP Session Down Event

When a BGP session goes down, the peer IP might not be unreachable. Therefore, BGP sends only a NextHopDown event to the Unified Forwarding Table Manager (UFTM) for a next hop advertised by the peer if it is not advertised by another peer. Upon receiving the NextHopDown event, UFTM fails over to the secondary BGP next hop. Following are the BGP session down processing events:

1. BGP session down detection: BGP detects the session down event and checks if the peer IP is used as a next hop by any routes.
2. NextHopDown event: If the peer IP is used as a next hop and not advertised by any other peer, BGP sends a NextHopDown event to UFTM.
3. Failover to secondary next hop: UFTM fails over to the secondary BGP next hop.
4. Route selection algorithm: BGP reruns the route selection algorithm and downloads the new primary and secondary paths to UFTM.

BFD Session Down Event

When a BFD session goes down, it's confirmed that the peer is unreachable. BGP checks if the peer IP is used as a nexthop by any routes and sends a NextHopDown event to UFTM if necessary. The following are the BFD session down processing event:

1. BFD session down detection: BFD detects the session down event and notifies BGP.
2. NextHopDown event: BGP checks if the peer IP is used as a nexthop and sends a NextHopDown event to UFTM if necessary.
3. Failover to secondary nexthop: UFTM fails over to the secondary BGP nexthop.
4. Route selection algorithm: BGP reruns the route selection algorithm and downloads the new primary and secondary paths to UFTM.

Configure BGP Prefix-Independent Convergence

You can enable BGP Prefix-Independent Convergence to accelerate data path convergence under failover conditions.

- **Enabling BGP PIC**

BGP PIC is disabled by default. To enable it, you can configure it for an address family under a VRF. When enabled, BGP will select primary and secondary paths and download them to Unified Forwarding Table Manager (UFTM).

- **Disabling BGP PIC**

When BGP PIC is disabled, BGP will run the route selection algorithm and select the best path. No secondary path will be selected, and only the best path will be downloaded to the hardware.

For details on syntax and parameters, see the *Extreme OS ONE SR Command Reference Guide*.

1. Enter global configuration mode.

```
device# configure terminal
```

2. Add VRF instance.

```
device# configure terminal
device(config)# vrf violet
```

3. Run the **router bgp** command.

```
device# configure terminal
device(config)# vrf violet
device(config-vrf-violet)# router bgp
device(config-vrf-bgp)#
```

4. Run the **address-family** command with IP4 or IPv6 unicast.

```
device# configure terminal
device(config)# vrf violet
device(config-vrf-violet)# router bgp
device(config-vrf-bgp)# address-family ipv4 unicast
device(config-vrf-bgp-ipv4u)#
```

5. Run the **prefix-independent-convergence** command and activate it.

```
device# configure terminal
device(config)# vrf violet
device(config-vrf-violet)# router bgp
device(config-vrf-bgp)# address-family ipv4 unicast
device(config-vrf-bgp-ipv4u)# prefix-independent-convergence
device(config-vrf-bgp-ipv4u)# activate
device(config-vrf-bgp-ipv4u)# exit
device(config-vrf-bgp)# address-family ipv6 unicast
device(config-vrf-bgp-ipv6u)# prefix-independent-convergence
device(config-vrf-bgp-ipv6u)# activate device(config-vrf-bgp-ipv6u)# exit
device(config-vrf-bgp)# address-family l2vpn evpn
device(config-vrf-bgp-l2vpn-evpn)# prefix-independent-convergence
device(config-vrf-bgp-l2vpn-evpn)# activate
device(config-vrf-bgp-l2vpn-evpn)#
```

BGP4 Graceful Restart

BGP Graceful Restart (GR) is a mechanism that provides the smooth restart of BGP sessions, minimizing disruptions to network routing and forwarding. During a restart, both BGP peers collaborate to maintain network stability, ensuring no route or topology changes occur. It minimizes network disruptions during BGP restarts or device reboots and ensures network stability and continuity. It comes with the following key functionalities:

- **Negotiation:** The GR capability is negotiated through BGP OPEN messages, and both peers must support GR for the feature to be activated.

- Restart Process: When a BGP session is lost, the GR helper router marks routes as "stale" but continues to forward packets using these routes for a predefined duration.
- Non-Stop Forwarding (NSF): Forwarding continues while the control plane converges, minimizing network disruptions.

When configuring restart timers with regular BGP timers, you should consider scale. Proper configuration of restart timers is crucial to ensure GR functionality.

Helper-Only mode is supported, where the router acts as a GR Helper by default if GR is not enabled under any AFI or SAFI.

Configure BGP Graceful Restart

Graceful Restart is not configured by default and must be explicitly configured at the instance level. It can be enabled or disabled at the AFI or SAFI level. Follow this procedure to configure BGP graceful restart.



Note

High availability (HA) requires Graceful Restart to be enabled.

1. Enter the **configure terminal** command to access global configuration mode.

```
device# configure terminal
```

2. Enter the config-vrf-bgp mode.

```
device# configure terminal
device(config)# vrf violet
device(config-vrf-violet)# router bgp
device(config-vrf-bgp) #
```

3. Configure graceful restart at the router BGP level.

```
device(config-vrf-bgp) # graceful-restart
device(config-vrf-bgp-gr) # restart-time 100
device(config-vrf-bgp-gr) # stale-route-time 500
device(config-vrf-bgp-gr) # helper-only
device(config-vrf-bgp-gr) #
```

4. Exit the config-vrf-bgp-gr mode.

```
device(config-vrf-bgp-gr) # exit
device(config-vrf-bgp) #
```

5. (Optional) Enter BGP peer group configuration mode.

```
device(config-vrf-bgp) # peer-group group1
device(config-vrf-bgp-pg) #
```

6. (Optional) Configure graceful restart at the router BGP peer group level.

```
device(config-vrf-bgp-pg) # graceful-restart
device(config-vrf-bgp-pg-gr) # restart-time 100
device(config-vrf-bgp-pg-gr) # stale-route-time 500
device(config-vrf-bgp-pg-gr) #
```

7. (Optional) Exit BGP peer group configuration mode.

```
device(config-vrf-bgp-pg-gr) # exit
device(config-vrf-bgp-pg) #
```

8. Enter the **address-family ipv4 unicast** command to enter IPv4 address-family configuration mode.

```
device(config-vrf-bgp)# address-family ipv4 unicast
device(config-vrf-bgp-ipv4u)#
```

9. Enter the **graceful-restart** command to enable the graceful restart feature.

```
device# configure terminal
device(config)# vrf violet
device(config-vrf-violet)# router bgp
device(config-vrf-bgp)# address-family ipv4 unicast
device(config-vrf-bgp-ipv4u)# graceful-restart
device(config-vrf-bgp-ipv4u)#
```

The following example enables the graceful restart mode for the IPv4 unicast address family:

```
device# configure terminal
device(config)# vrf violet
device(config-vrf-violet)# router bgp
device(config-vrf-bgp)# address-family ipv4 unicast
device(config-vrf-bgp-ipv4u)# graceful-restart
device(config-vrf-bgp-ipv4u)#
```

The following example displays the configuration of a VRF instance named violet that is running currently on the device. In this example, the routing process is configured to enable graceful restart (with a restart timer and a stale route time of 100 seconds and 500 seconds respectively) on its neighbors:

```
device# show running-config vrf violet

vrf violet
  router bgp
    address-family ipv4 unicast
      graceful-restart    !
    !
  !
device#
```

The following example shows CLI output where BGP routes are marked as stale:

```
device# show bgp vrf default-vrf routes ipv4-unicast

BGP routing table information for VRF default-vrf
Status: *-valid, >-best, S-stale
Path type: i-internal, e-external, l-local, r-redist, m-multipath, a-additional,
           p-primary, s-secondary
Origin codes: I - IGP, E - EGP, ? - incomplete
IPv4 Routes
-----
Total number of routes: 5
Flags      Prefix                Nexthop              Peer
=====
*>Ie      203.0.113.3/32        198.51.100.1         198.51.100.1
*>?Si     198.51.100.0/24      198.51.100.1         198.51.100.1
*>?Si     192.0.2.0/24         198.51.100.1         198.51.100.1
*>ISi     192.0.2.1/32         198.51.100.1         198.51.100.1
*>Ie     203.0.113.0/24       198.51.100.1         198.51.100.1

device# show bgp vrf default-vrf routes ipv4-unicast 198.51.100.0/24
```

```
Prefix: 198.51.100.0/24, Nexthop: 198.51.100.1, Peer: 198.51.100.1, AS Path:  
Age: 42s, Status:VALID Path-Type: Best, Stale, Internal,  
Origin: INCOMPLETE  
device#
```

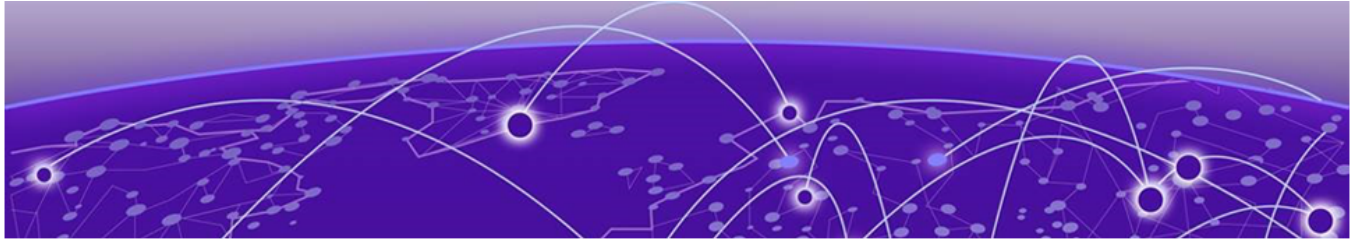

BGP Ethernet VPN for IP Fabrics

[BGP EVPN for IP Fabrics Features and Benefits](#) on page 141

[Data Center IP Fabric Architecture](#) on page 143

[MAC Synchronization \(Type 2\)](#) on page 150

[Layer 2 Extension](#) on page 152

[Layer 3 Extension](#) on page 152

[EVPN Model Overview](#) on page 153

[BGP EVPN Configuration Examples](#) on page 155

The following topics describe how to configure BGP Ethernet VPN for IP fabrics.

BGP EVPN for IP Fabrics Features and Benefits

Ethernet VPN (EVPN) provides a standards-based solution for data center overlay and data center interconnect (DCI).

BGP EVPN (Ethernet VPN) is a control plane solution for Ethernet Layer 2 and Layer 3 VPN services, ideal for data centers and large-scale networks. It uses BGP to provide a scalable and flexible network virtualization solution, extending Ethernet services across geographically dispersed sites.

[RFC 7432](#) (BGP MPLS-Based Ethernet VPN) specifies multiprotocol extensions to BGP to exchange Layer 2 routes in an MPLS Ethernet VPN network. These extensions are useful in DCI scenarios.

A BGP EVPN-based IP Fabric consists of BGP EVPN for VxLAN overlay networks and a broad set of Layer 2, Layer 3, and infrastructure features to provide seamless deployment, on-demand usage of forwarding entries in hardware, and minimization of flooding in the network.

Key Features

BGP EVPN for IP Fabrics has the following key functionalities:

- BGP EVPN route propagation occurs only at the spine level for the control plane in Leaf and Spine architecture.
- Dynamic VTEP discovery and VxLAN tunnel formation simplifies network setup and management.

- Route exchange supports Layer 2 MAC, MAC-IP (ARP or ND), and Layer 3 prefix routes, including Multi-VRF and symmetric or asymmetric routing.
- BGP EVPN for IP Fabrics supports logical VTEP support, static anycast gateway, ARP suppression, but no multi-homing support.

Key Benefits

BGP EVPN for IP Fabrics has the following key benefits:

- Multi-tenancy support: Each tenant's traffic is isolated, crucial for cloud data centers and service provider networks.
- Integrated control plane: BGP EVPN combines Layer 2 and Layer 3 forwarding to provide efficient forwarding and unified management.
- Efficient BUM traffic handling: The control plane disseminates information to reduce flooding typically required in traditional Ethernet networks.

Build Modern Data Centers with VxLAN and BGP

The rapid growth of applications and storage in data centers has led to new challenges in providing scalable and efficient connectivity between virtual machines (VMs). Traditional solutions such as VPLS (Virtual Private LAN Service) have limitations in terms of redundancy, multicast optimization, and provisioning simplicity.

Limitations of Traditional Solutions

Current VPLS solutions lack support for flexible multihoming with all-active redundancy mode and have complex provisioning requirements. Also, traditional data center designs, such as port channel-based designs, have limitations in terms of bandwidth utilization, scalability, and network resilience.

Evolution of Data Center Networks

Data center networks have evolved significantly over the past decade, with new technologies and designs emerging to address the limitations of traditional solutions. The use of VxLAN and BGP in data center networks offers a promising solution for building massive, scalable, and efficient data centers.

VxLAN and BGP: A New Approach

VxLAN (Virtual Extensible LAN) and BGP (Border Gateway Protocol) can be used to build modern data centers that are scalable, efficient, and resilient. By using these technologies, you can create a network that supports flexible multihoming, efficient traffic management, and simplified provisioning.

Use the following sections to learn how VxLAN and BGP can be used to build a large data center.

Data Center IP Fabric Architecture

A typical data center deployment consists of three types of devices:

1. Leaf devices: Connected to physical servers or hypervisors hosting virtual machines (VMs)
2. Spine devices: Interconnected with leaf devices in a Clos fabric topology, providing multiple paths for efficient traffic load-balancing and redundancy
3. Border nodes: Devices that connect the data center to external networks, handling north-south traffic

Key Characteristics

1. Clos fabric topology: A matrix of interconnections between network devices, enabling horizontal scalability and efficient traffic management.
2. IP-based connectivity: The fabric is built on IP connectivity, allowing for flexible and scalable network design.
3. Point of Delivery (PoD): A group of leaf and spine devices that can be interconnected using super spines to form a larger data center.

Border Node Functionality

The border node, whether a border leaf or border spine, sits at the edge of the data center and provides connectivity to external networks. This provides access to services, applications, or servers from the internet.

Benefits

1. Scalability: The IP fabric architecture provides horizontal scalability, making it easy to add new devices and increase capacity.
2. Redundancy and resiliency: Multiple paths between leaf devices ensure efficient traffic load-balancing and redundancy.
3. Efficient traffic management: The Clos fabric topology provides efficient traffic management, reducing the risk of network congestion and downtime.

Underlay Network

The underlay network provides IP connectivity between devices in a data center fabric. A routing protocol is needed to provide IP reachability and Layer 3 capabilities like ECMP and load balancing.

BGP as Underlay Protocol

BGP (Border Gateway Protocol) is commonly used as the underlay protocol in data center fabrics. There are two options for building the underlay using BGP:

- iBGP (Internal BGP): Leaf devices establish iBGP sessions with spine devices, and spine devices act as route reflectors. Each leaf and border node has a dedicated loopback address that serves as a VTEP endpoint.
- eBGP (External BGP): Each leaf device is configured in a different AS, while all spine devices are in a single AS, and all border nodes are in a single AS. eBGP multipath is enabled for load balancing IP traffic.

Key Features

Underlay networks provide the following key features:

- IP reachability: BGP provides IP reachability between devices in the fabric.
- ECMP and load balancing: BGP provides ECMP and load balancing features, ensuring efficient traffic management.
- L2VPN EVPN: BGP negotiates L2VPN EVPN address family to synchronize overlay network addresses (MAC, ARP, or prefix routes).

Benefits

Underlay networks provide the following overall benefits:

- Scalability: BGP-based underlay architecture provides scalable and efficient network design.
- Flexibility: Both iBGP and eBGP options provide flexibility in designing the underlay network.
- Efficient traffic management: BGP provides efficient traffic management, reducing the risk of network congestion and downtime.
- Recommendation: Physical interface or Port-channel used as underlay (L3 interface) for VxLAN tunnel should not be part of any Bridge-domain or sub-interface configuration.

Overlay Networks

With the underlay network in place, each device in the fabric has reachability to interface and loopback addresses. This is a prerequisite for setting up overlay networks.

Overlay networks are logical or virtual tunnels that enable communication between Virtual Machines (VMs) or resources placed on physical servers. These networks can support Layer 2 or Layer 3 transport between VMs, applications, or services, while hiding the underlying network infrastructure.

By using overlay networks like VXLAN, you can create a scalable and flexible network architecture that supports multiple applications and services.

Key Components

Overlay networks have the following key components:

- **Tunnel Encapsulation:** Each tunnel consists of a tenant ID that acts as a demultiplexer to distinguish between different traffic streams.
- **Control Plane:** The control plane exchanges VM or tenant application topology information (MAC addresses and IP routes) between tunnel endpoints.
- **Data Plane Encapsulation:** The data plane encapsulates and forwards traffic between overlay tunnel endpoints across the virtual tunnel.

VXLAN and VXLAN Tunnel Endpoints (VTEPs)

VXLAN is a tunneling encapsulation that can be used to transport data packets over an underlying IP network. It uses a MAC-in-UDP encapsulation to extend Layer 2 segments, providing a Layer 2 overlay over a Layer 3 network.

Each Leaf and Border Node has a loopback interface configured as a VTEP. VXLAN tunnels can be statically provisioned or dynamically created using protocols like BGP.

Benefits

Overlay networks, such as VXLAN, have the following benefits:

- Layer 2 and Layer 3 connectivity between VMs, applications, or services
- Network virtualization, which hides the underlying network infrastructure
- Scalability to support multiple tenants and services

Layer 2 or Layer 3 Multitenancy with VxLAN

In a multitenant environment, Virtual Machines (VMs) deployed on servers behind Leaf nodes may require Layer 2 or Layer 3 connectivity between them. To achieve this, data packets are encapsulated in VxLAN packets at the ingress Leaf and routed across the fabric to the egress Leaf, where they are tunnel-terminated and forwarded to the destination VM.

By using VxLAN VNIs, you can provide scalable and flexible Layer 2 and Layer 3 multitenancy in your network.

VLAN and VNI Mapping

Each tenant's traffic is segregated using VLANs, which are mapped to a tenant ID or VNI (VxLAN Network Identifier). A VNI represents a broadcast domain, similar to a VLAN, but in the Layer 3 world. There are two types of VNIs:

- L2VNI represents a Layer 2 broadcast domain, used for bridging traffic.
- L3VNI represents a Layer 3 domain or VRF, used for routing traffic.

Key Concepts

A VNI is carried in the VxLAN header to map traffic to the correct broadcast domain or VRF.

A bridge domain (BD) represents a VLAN or broadcast domain in Extreme OS ONE. Each bridge domain uses a unique L2VNI, while each routed domain uses a unique L3VNI to identify the VRF. Incoming VLANs are mapped to L2VNIs for bridging or L3VNIs for routing.

While VLANs and VRFs have local significance, VNIs are globally significant. VxLAN VNIs provide Layer 2 or Layer 3 isolation across the fabric, enabling multitenancy.

Basic Terminologies

The following key terms are used in these topics:

1. **Bridge Domain:** A single broadcast domain, which can be mapped to a single VLAN domain or group of VLAN domains. Each bridge domain has a MAC table for Layer 2 bridging.
2. **EVPN Instance:** A logical binding of bridge domains that participate in a single broadcast domain across multiple devices. EVPN instances can represent a single broadcast domain or a group of broadcast domains.
3. **MAC-VRF:** A representation of Layer 2 forwarding instance, mapped to a single EVPN instance.
4. **L3 Interface:** A logical Layer 3 interface (VE) associated with a single VRF instance, linked to a bridge domain and EVPN instance.
5. **VRF Instance:** A virtual routing and forwarding Layer 3 instance, representing a specific customer Layer 3 constructs.
6. **NVE (Network Virtualization Edge):** A device capable of handling VxLAN tunneled packets, originating and terminating VxLAN tunnels based on VTEP IPs.
7. **NVO (Network Virtualization Overlay):** A group of devices with the same VNI-domain mapping, extending Layer 2 or Layer 3 domains.

Key Concepts

Devices in the same NVO must have the same VNI-domain mapping to extend Layer 2 or Layer 3 domains.

VLAN-based Service interface represents a single broadcast domain, while VLAN-bundle service interface represents a group of broadcast domains.

IP Topology

Use this topic to view the topology diagram of 3-Stage Clos and 5-Stage Clos.

3-Stage Clos with Border Leaves

[Figure 11](#) shows an example of 3-Stage Clos with border leaves.

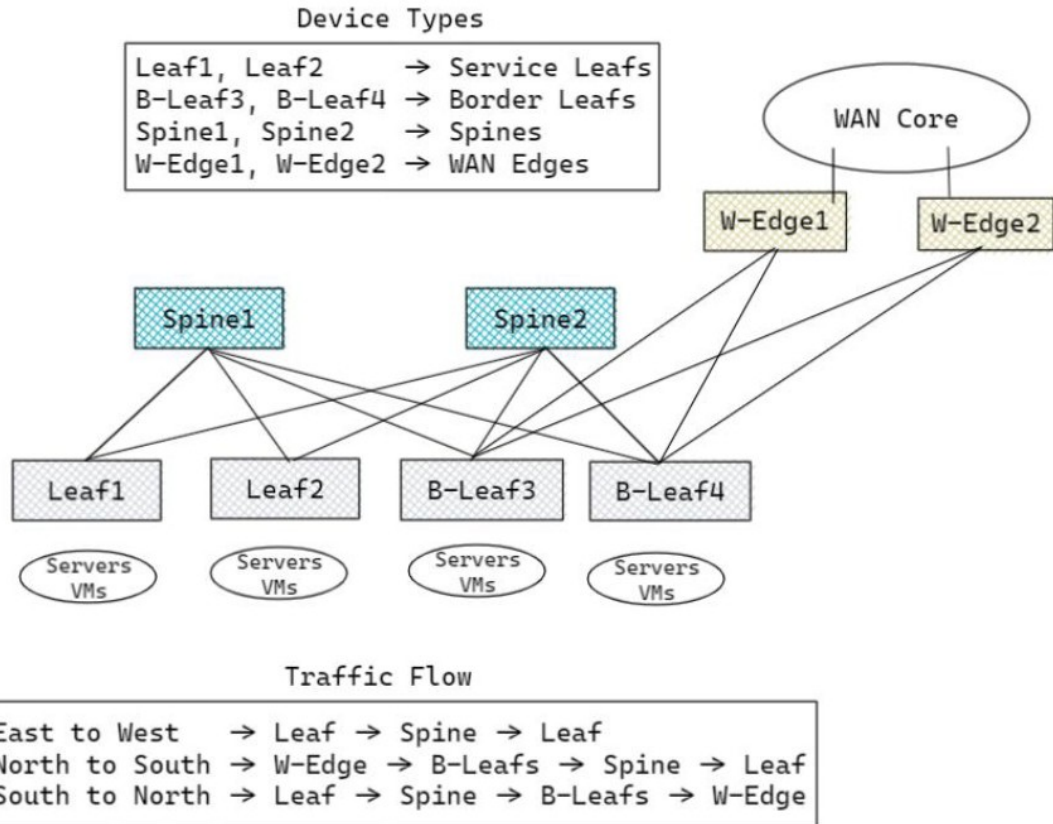

Figure 11: 3-Stage Clos with border leaves

3-Stage Clos with Collapsed Spines

Figure 12 shows an example of 3-Stage Clos with collapsed spines.

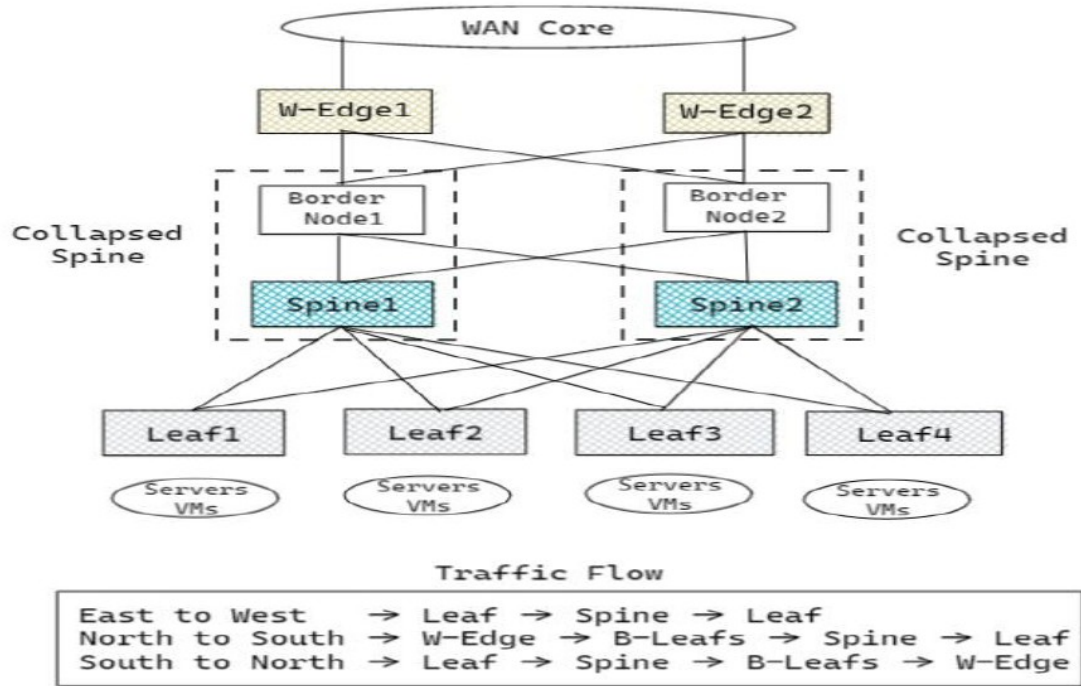

Figure 12: 3-Stage Clos with collapsed spines

5-Stage Clos

Figure 13 shows an example of 5-Stage Clos.

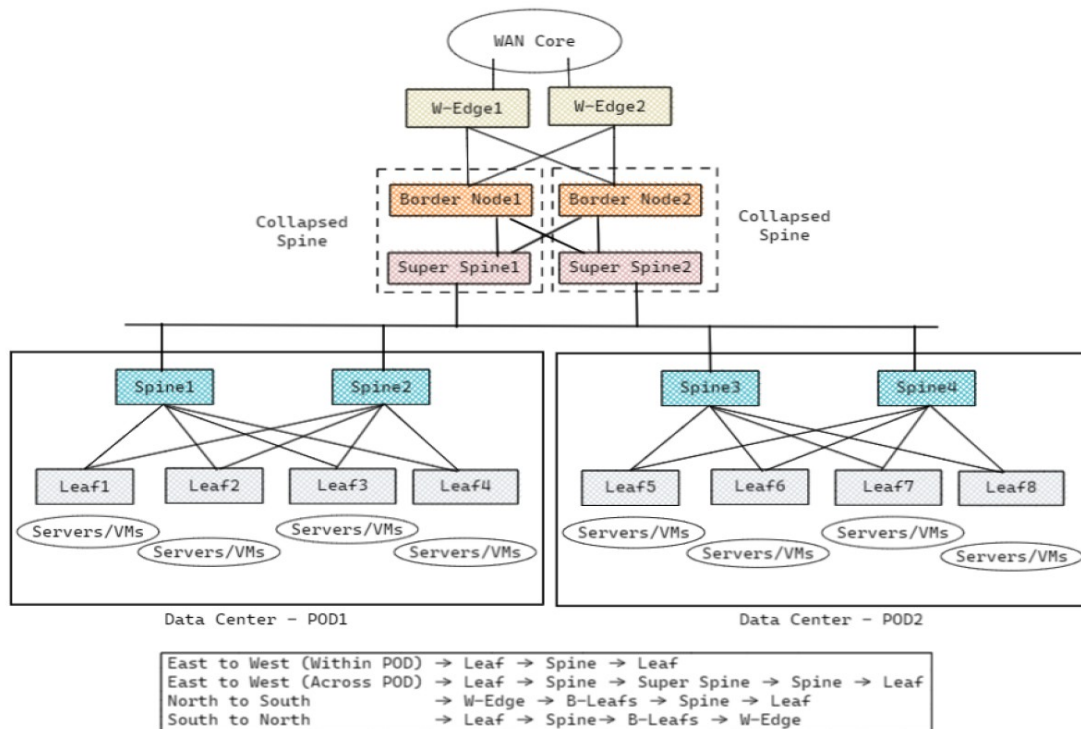

Figure 13: 5-Stage Clos

Sample Topologies

Figure 14 shows a sample topology with EVPN multihoming.

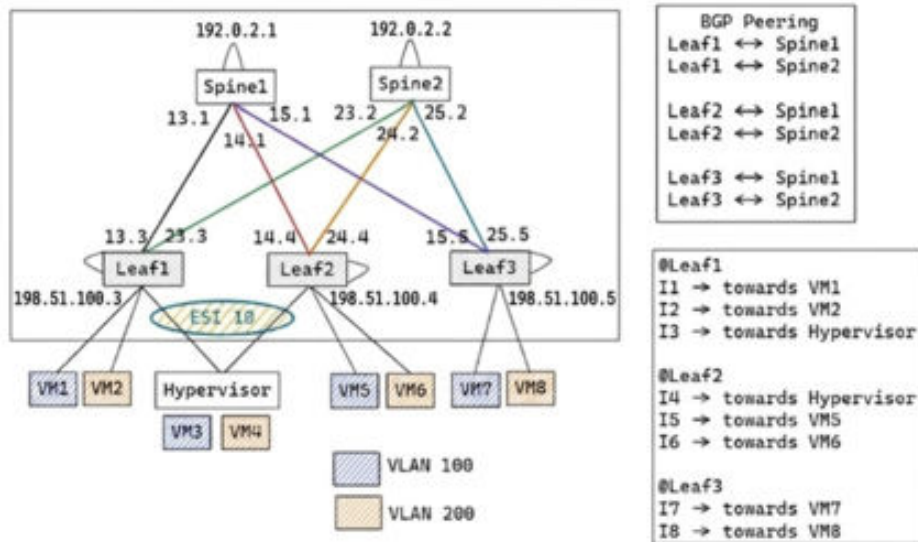

Figure 17: Sample Topology with Physical connections

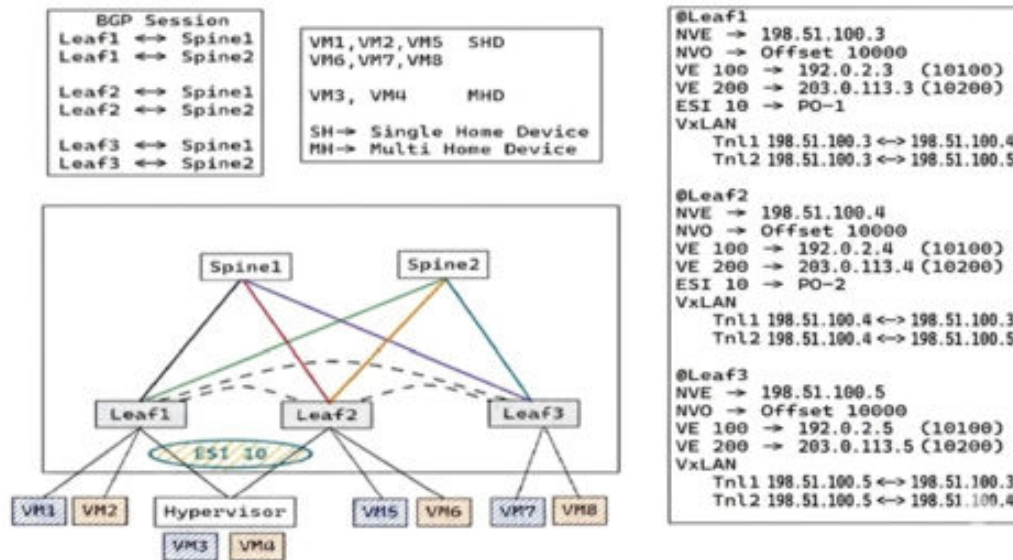

Figure 14: Sample topology with EVPN multihoming

Figure 15 shows a sample topology with MLAG and EVPN.

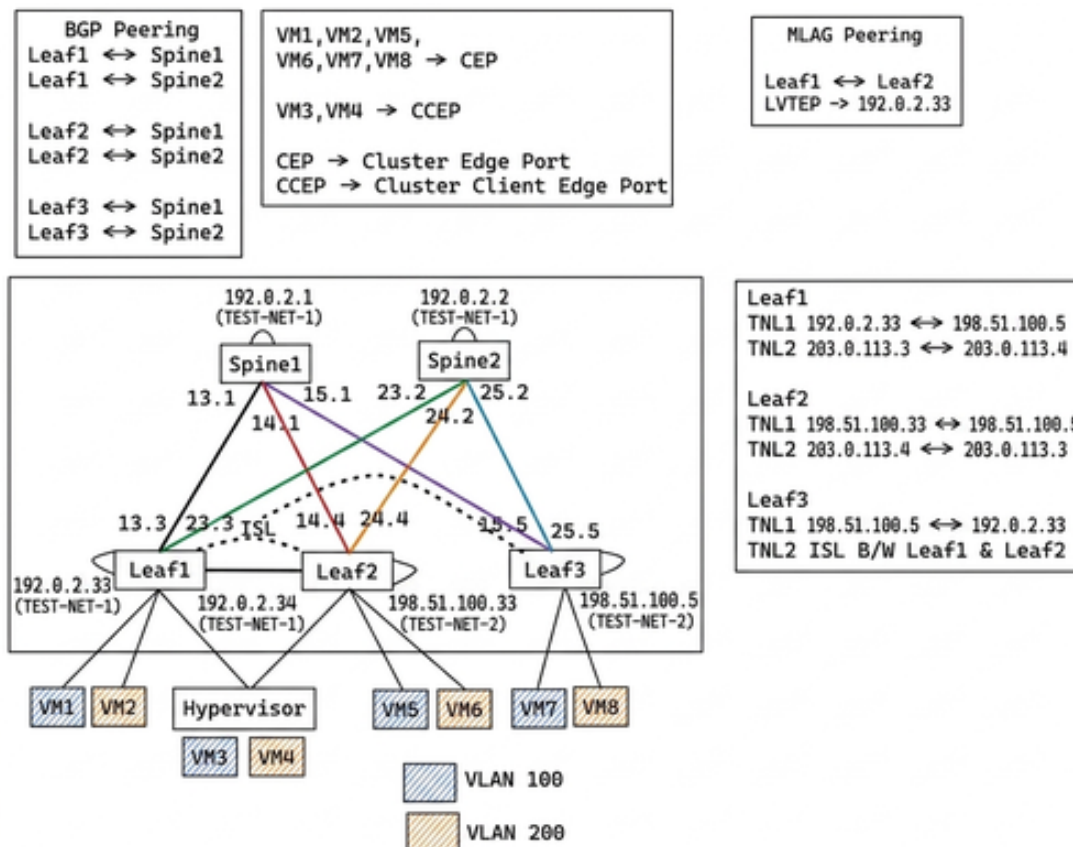

Figure 15: Sample topology with MLAG and EVPN

MAC Synchronization (Type 2)

In an EVPN network, MAC synchronization is crucial for efficient traffic forwarding. When a device learns a new MAC address, it propagates this information to other devices in the network.

Local MAC Learning

The following is step-by-step overview of how MAC learning works:

1. A device receives a packet with an unknown destination MAC address and floods it across all member ports in the VLAN.
2. The packet is also sent over a tunnel to other devices in the network, which terminate the tunnel and perform local flooding.
3. The device that learns the new MAC address updates its hardware cache and propagates the MAC learned event to BGP.
4. BGP originates a Type 2 MAC route, which carries the MAC address, BD ID, and source interface information.
5. The MAC route is advertised to other devices in the network, which import it if it matches their configured RT.

MAC Route Origination

When a device originates a MAC route, it includes the following information:

- MAC address
- Bridge domain ID
- Source interface (IFINDEX)
- Sequence number (to ensure correct MAC/IP advertisement route retention)
- Sticky bit (for static MAC routes)

Received MAC Routes

When a device receives a MAC Type 2 route, it goes through regular EVPN route processing. If the route is imported, the device updates its MAC table with the received information.

End-to-End Data Path

The following steps provide an overview of how L2 traffic is forwarded across the fabric:

1. A packet is received at a device, which performs a MAC lookup to determine the exit path.
2. The packet is encapsulated in a VxLAN header and routed towards the destination VTEP.
3. The packet is forwarded across the fabric, potentially being load-balanced across multiple spines.
4. The destination device terminates the tunnel, performs MAC lookup, and forwards the original L2 frame to the destination port.

MLAG Considerations

When MLAG is involved, MAC learning and route origination work slightly differently:

1. A device learns a new MAC address and synchronizes it with its MLAG peer.
2. The device originates a MAC route, which is advertised to BGP peers.
3. The MLAG peer also installs the remote MAC pointing to the ISL.

MAC Route Selection

The device selects the best MAC route source based on distance. The selected source is then propagated to other microservices, such as Fwd-HAL, BGP, and MLAG.

MAC Move

When a MAC address moves within a device or between devices, the device updates its MAC table and propagates the new information to other devices in the network.

Layer 2 Extension

IMR routes enable Layer 2 extension over a fabric by indicating device interest in extending specific Layer 2 domains. Tunnel creation is triggered by BGP when an IMR route is received from a peer. MLAG setups use a shared VTEP IP, which provides multiple devices access to the same tunnel.

Layer 3 Extension

ARP or ND Synchronization and Routing

This section explains how ARP or ND synchronization works in a network, including local ARP or ND learning, propagation of ARP or ND learn events, and origination of ARP or ND routes.

Local ARP or ND Learning

When a device receives an ARP packet, it updates its ARP cache and routing table with the source MAC-IP binding. The device then originates a Type 2 MACIP route, which carries the MAC address, IP address, BD, and VRF information.

Propagation of ARP or ND Learn Events

The ARP or ND learn event is propagated to other devices in the network through BGP. Each device imports the MACIP route into its EVPN instance and VRF instance, updating its ARP cache and routing table accordingly.

Origination of ARP or ND Routes

The origination of ARP or ND routes involves several key components:

- **Sequence Number:** A sequence number is used to ensure that devices retain the correct MAC or IP advertisement route when multiple updates occur for the same MAC address.
- **Static ARP:** You can configure static ARP entries, which are then propagated to other devices in the network.
- **Route Selection:** The system performs route selection based on the source of the route, with different distances associated with each source (such as local, BGP, MLAG, or static).

Asymmetric and Symmetric Routing

The system supports both asymmetric and symmetric routing:

1. **Asymmetric Routing:** In asymmetric routing, the packet is forwarded based on the ARP cache, and the DMAC is set to the destination VMs MAC address.

2. Symmetric Routing: In symmetric routing, the packet is forwarded based on the IP VRF routing table, and the DMAC is set to the egress leaf's MAC address.

MLAG and Route Selection

The system also supports Multichassis Link Aggregation Group (MLAG) and performs route selection based on the source of the route.

Centralized vs. Distributed Routing

The system can operate in either centralized or distributed routing modes, each with its own advantages and disadvantages.

EVPN Model Overview

The EVPN standard (RFC 7432) defines two Layer 2 VLAN services applicable to VxLAN-based implementations:

- VLAN-Based Service Interface: A single bridge domain is mapped to a single EVPN instance, providing a 1:1 mapping between EVPN instance, MAC-VRF, and bridge domain. This approach provides granular route import or export at the bridge domain level but requires one EVPN instance per bridge domain.
- VLAN-Aware Bundle Service Interface: Multiple bridge domains can be mapped to a single EVPN instance, sharing the same RD and RT set. This approach reduces EVPN instance configuration requirements but lacks granularity in importing or exporting routes on a per bridge domain basis.

Key Differences

The differences between a VLAN-Based Service Interface and a VLAN-Aware Bundle Service Interface are as follows:

1. VLAN-Based: 1:1 mapping between EVPN instance and bridge domain, granular route control, but more configuration required.
2. VLAN-Aware Bundle: Multiple bridge domains per EVPN instance, reduced configuration, but less granular route control.

Implications

The choice between VLAN-Based and VLAN-Aware Bundle service interfaces depends on the specific network requirements and the trade-off between configuration complexity and route control granularity.

Module Interactions for BGP EVPN

The following sections outline the interactions between BGP and other subsystems to support EVPN functionality.

GP and Management Service Interaction

The Management Service needs to be enhanced to support EVPN, including the following configurations:

1. EVPN instance: Installing EVPN instance configuration commands.
2. VRF instance: Installing VRF instance configuration commands.
3. ESI: Installing ESI configuration commands.
4. BGP-specific: Installing BGP-specific configuration commands for EVPN.

BGP and Interface Manager Interaction

The Interface Manager supports EVPN functionality, including the following features:

- Handling of tunnel creation and deletion requests from BGP
- L2VNI and L3VNI membership (adding or deleting BGP-triggered tunnels between L2VNI and L3VNI)
- Bridge domain commands to map EVPN instances
- Enhanced overlay configuration to have a single VNI-domain per NVO

BGP and UFTM Interaction

The Unified Forwarding Table Manager (UFTM) supports EVPN functionality, including the following features:

1. Remote MAC route installation: Installing, deleting, or updating remote MAC routes pointing to VxLAN tunnels
2. Remote ARP route installation: Installing, deleting, or updating remote ARP routes pointing to VxLAN tunnels
3. Next hop resolution: Resolving next hops for VTEPs (BGP next hops)

BGP and Forward HAL Interaction

Fwd-HAL supports EVPN functionality, including blocking rules to prevent traffic for non-designated forwarders and port channels.

BGP and Kernel Interaction

BGP packets are sent and received through the kernel with no requirements for BGP EVPN.

BGP and ARP/ND Interaction

The ARP or ND module supports EVPN functionality, including remote ARP route installation. This includes installing, deleting, or updating remote ARP routes pointing to VxLAN tunnels and handling MAC sync requests for L2VNIs.

BGP EVPN Configuration Examples

BGP EVPN Neighbor Configuration Examples

This section presents configuration examples of basic BGP EVPN neighbor configurations.

Configuring a BGP EVPN Peer Group

The following example shows how to use the **peer-group** command to configure a BGP peer group within a VRF instance:

```
device# configure terminal
device(config)# vrf default-vrf
device(config-vrf-default-vrf)# router bgp
device(config-vrf-bgp)# local-as 3
device(config-vrf-bgp)# peer-group BGPEVPN2
device(config-vrf-bgp-pg)# remote-as 1
device(config-vrf-bgp-pg)# nvo nvo1
device(config-vrf-bgp-pg)# timers
device(config-vrf-bgp-pg-timers)# hold-time 30
device(config-vrf-bgp-pg-timers)# exit
device(config-vrf-bgp-pg)# address-family ipv4 unicast
device(config-vrf-bgp-pg-ipv4u)# activate
device(config-vrf-bgp-pg-ipv4u)# exit
device(config-vrf-bgp-pg)# exit
device(config-vrf-bgp-pg)# address-family l2vpn evpn
device(config-vrf-bgp-pg-l2vpn-evpn)# activate
device(config-vrf-bgp-pg-l2vpn-evpn)# exit
device(config-vrf-bgp-pg)# neighbor 192.0.2.0
device(config-vrf-bgp-pg-neighbor)# exit
device(config-vrf-bgp-pg)# neighbor 192.0.2.1
device(config-vrf-bgp-pg-neighbor)#
```

As with any VPN technology, EVPN neighbors must always be in the default VRF. The preceding example shows an EVPN address family being activated for IPv4 BGP neighbors.

Retaining EVPN Routes without Importing Them

For spine or specific border leaf cases, routes are not imported into MAC-VRF or IP-VRF tables, but instead are reflected or re-advertised to iBGP or eBGP peers. The following configuration is required to retain all of the routes in the VPN table:

```
device# configure terminal
device(config)# vrf default-vrf
device(config-vrf-default-vrf)# router bgp
device(config-vrf-default-bgp)# address-family l2vpn evpn
device(config-vrf-bgp-l2vpn-evpn)# retain-route-target-all
device(config-vrf-bgp-l2vpn-evpn)#
```

Keeping Next-Hop Unchanged for eBGP Neighbors

When BGP advertises received routes to an eBGP peer, the next-hop value in the route is modified to carry the local peering IP address. In the case of a BGP EVPN VxLAN IP Fabric, the next-hop value in the route is the VTEP IP address of the advertising router. A BGP EVPN spine distributing the routes to other leaf nodes should not modify the

next-hop value. Each eBGP peer activated under an EVPN address family should be configured so that it does not modify the next-hop value, as in the following example:

```
device# configure terminal
device(config)# vrf default-vrf
device(config-vrf-default-vrf)# router bgp
device(config-vrf-bgp)# peer-group BGPEVPN2
device(config-vrf-bgp-pg)# address-family l2vpn evpn
device(config-vrf-bgp-pg-l2vpn-evpn)# nexthop-unchanged
device(config-vrf-bgp-pg-l2vpn-evpn)#
```

Configuring iBGP EVPN Neighbors

In a full iBGP mesh of EVPN nodes, a leaf node needs to peer only with all other leaf nodes. It does not need a session with any spine node. The configuration of a route-reflector client on the spine nodes is not required.

In a non-full iBGP mesh configuration, to reflect routes from one iBGP neighbor to another iBGP neighbor, the iBGP neighbors should be configured as route-reflector clients, as in the following example:

```
device# configure terminal
device(config)# vrf default-vrf
device(config-vrf-default-vrf)# router bgp
device(config-vrf-bgp)# address-family l2vpn evpn
device(config-vrf-bgp-l2vpn-evpn)# peer-group BGPEVPN2
device(config-vrf-bgp-pg)# route-reflector-client
```

The "client-to-client-reflection" feature is by default enabled under the EVPN address family.

The route-reflector configuration does not force routes that are not imported to be retained in BGP. The **retain route-target-all** command as described previously is required in all cases.

Negotiating only EVPN Address Family

For better resiliency, separate BGP neighbors for overlay and underlay may be desired. This separation lets you manipulate, debug, and maintain EVPN neighbors without affecting underlay connectivity. This separation can be achieved by deactivating the underlay address family for EVPN neighbors.

IPv4 neighbors are automatically activated under the IPv4 unicast address family, and they must be deactivated as in the following example:

```
device# configure terminal
device(config)# vrf default-vrf
device(config-vrf-default-vrf)# router bgp
device(config-vrf-bgp)# peer-group BGPEVPN2
8730-32d(config-vrf-bgp-pg-ipv4u)# address-family ipv4 unicast
8730-32d(config-vrf-bgp-pg-ipv4u)# no activate
8730-32d(config-vrf-bgp-pg-ipv4u)# exit
8730-32d(config-vrf-bgp-pg)# address-family l2vpn evpn
8730-32d(config-vrf-bgp-pg-l2vpn-evpn)# exit
8730-32d(config-vrf-bgp-pg)# exit
8730-32d(config-vrf-bgp)# peer-group BGPEVPN2
8730-32d(config-vrf-bgp-pg)# address-family l2vpn evpn
```

```
8730-32d(config-vrf-bgp-pg-l2vpn-evpn)# activate
8730-32d(config-vrf-bgp-pg-l2vpn-evpn)#
```

Displaying the BGP EVPN Neighbor Configuration

The following example displays the configuration of the default VRF instance that is running currently on the device.

```
device# show running-config vrf default-vrf

vrf default-vrf
  evpn-instance evpn1
    nve nve2
    ignore-as
    bridge-domain 21,44,100,200,222,300
  !
  router bgp
    local-as 3
    address-family ipv4 unicast
    address-family l2vpn evpn
      retain-route-target-all
    !
    peer-group BGPEVPN2
      remote-as 1
      nvo nvo1
      timers
        hold-time 30
      !
      route-reflector-client
      address-family ipv4 unicast
      address-family l2vpn evpn
        activate
      !
      neighbor 192.0.2.0
      neighbor 192.0.2.1
    !
  !
!
```

BGP EVPN Instance Configuration Examples

With a VLAN-based service model, each VLAN or BD corresponds to a unique EVPN instance, or MAC-VRF. Each route in EVPN belonging to a MAC-VRF has a unique route distinguisher (RD) that differentiates routes from other MAC-VRFs.

In addition, sets of route targets (export RTs) are associated with each MAC-VRF. These RTs are applied to the routes while advertising. RTs in the route are matched against the configured import RTs. If any of the RTs match, the route is imported. Otherwise, it is discarded.



Note

Auto RD is mandatory for EVI extension with manual RD and RT/auto RT.

The following example associates an EVPN instance named `evpn1` with the default VRF and configures the instance:

```
device# configure terminal
device(config)# vrf default-vrf
```

```

device(config-vrf-default-vrf)# evpn-instance evpn1
device(config-evpn-evpn1)# nve nve2
device(config-evpn-evpn1)# ignore-as
device(config-evpn-evpn1)# bridge-domain 21,44,100,200,222,300
device(config-evpn-evpn1)#

```



Note

Configuration of an EVPN instance is supported only for the default VRF (not for any other user-configured VRF instance).

In this example, the instance uses the **ignore-as** command to ignore the local AS in the AS path of a received EVPN route. Such routes are accepted as valid routes and might qualify for best path selection.

The following example displays the configuration of the default VRF that is running currently on the device. In this example, an EVPN instance named `evpn1` is configured:

```

device# show running-config vrf default-vrf

vrf default-vrf
  evpn-instance evpn1
    nve nve2
    ignore-as
    bridge-domain 21,44,100,200,222,300
  !
router bgp
  local-as 3
  address-family ipv4 unicast
  address-family l2vpn evpn
    retain-route-target-all
  !
  peer-group BGPEVPN2
    remote-as 1
    nvo nvo1
    timers
      hold-time 30
  !
  route-reflector-client
  address-family ipv4 unicast
  address-family l2vpn evpn
    activate
  !
  neighbor 192.0.2.0
  neighbor 192.0.2.1
  !
!
!
!

```

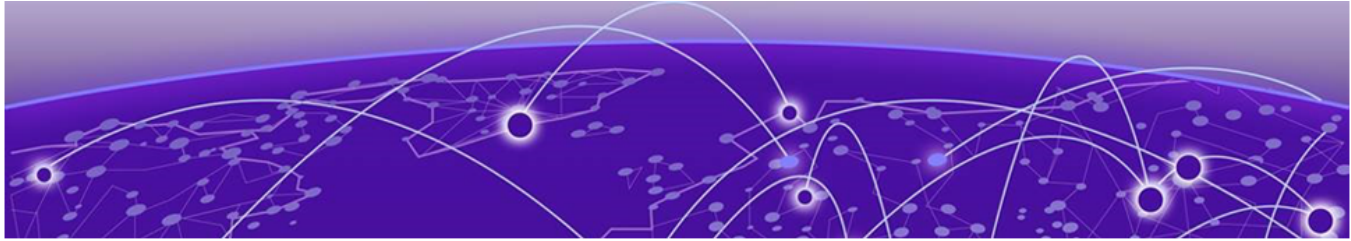

Static VxLAN

- [Static VxLAN Overview](#) on page 159
- [Static VxLAN Limitations](#) on page 160
- [Event Log Messages](#) on page 161
- [Configure Static VxLAN](#) on page 161

Use this topic to learn about the configuration and behavior of static VxLAN tunnels for Layer 2 or Layer 3 traffic.

Static VxLAN Overview

The configuration setup involves VxLAN L2 gateways (Leaf 1, 2, and 3) that extend bridge domains through VxLAN tunnels.

Traffic Behavior

The following list describes Static VxLAN traffic behavior:

- **BUM Traffic:** When traffic arrives on AC ports without a MAC table entry, it is flooded to VxLAN tunnels that are members of the bridge domain using head-end replication.
- **MAC Learning:** MAC addresses are learned over VxLAN tunnels, and the source MAC address of the inner payload is used for learning.

The **show mac-address-table** command displays MAC address entries for a bridge domain, including static and dynamic entries learned over VxLAN tunnels.

```
device# show mac-address-table bridge-domain 500

Total number of Mac Entries: 2
Hardware Status Codes - #:Failed
Mac-Address                Type                Interface
-----
00:10:20:30:40:50          Static              ethernet 0/33.90133
00:10:20:30:AA:AA          Dynamic             tunnel 2001:db8::1
device#
```

- **VxLAN Tagging:** VLAN tags are stripped before sending traffic over VxLAN tunnels in VLAN mode and default mode bridge domains.

Split Horizon

Each NVO is configured with a split horizon group, and BUM traffic received on a VxLAN tunnel is not flooded to another tunnel in the same group. BUM traffic received on a VxLAN tunnel in one split horizon group can be flooded to VxLAN tunnels in other groups.

Head-End Replication

When traffic arrives on the access ports but does not find a MAC table entry, it is flooded to the VxLAN tunnels that are members of the bridge domain. In this case, head end replication sends a copy of the same packet over multiple VxLAN tunnels.

Sample Topology

A sample configuration involves VxLAN Layer 2 gateways (Leafs 1, 2, and 3) that extend bridge domains through VxLAN tunnels. Key components of this topology are as follows:

- VxLAN Tunnels: Leaf 1 and Leaf 3 are connected through two VxLAN tunnels (Tunnel 1 and Tunnel 2) that extend bridge domains 500 and 600, respectively.
- Bridge Domains: Bridge domain 500 is extended to Leaf 3 through VxLAN Tunnel 1, and bridge domain 600 is extended to Leaf 3 through VxLAN Tunnel 2.
- Host Mapping: Host H1 on bridge domain 500 is mapped to VNI 500, and traffic from H1 is flooded to VNI 500 on remote leaf nodes through VxLAN Tunnel 1.

Example Output

The **show mac-address-table** command displays MAC address entries for a bridge domain, including static and dynamic entries learned over VxLAN tunnels.

Static VxLAN Limitations

The Extreme 8730 platform has the following limitations:

- VxLAN Traffic Termination: VxLAN traffic will be terminated with the correct VTEP IP and VNI even if the tunnel is not extended in the bridge domain.
- Tunnel Underlay: Tunnel underlay is only supported in the default VRF.
- Single VNI Domain: Only a single VNI domain is supported.
- Single VxLAN Next hop: A single VxLAN next hop (underlay) is supported per physical port or port-channel. This results in the following restrictions:
 - Multiple IPv4 tunnels can share the same underlay, but more than one IPv4 VxLAN next hop is not supported on the same port.
 - More than one IPv6 VxLAN next hop is not supported on the same port.
 - IPv4 and IPv6 tunnels cannot share a next hop.
 - IPv6 tunnels with different source VTEP IPs cannot share a next hop.
- MAC Learning: MAC learning continues to happen on the static VxLAN tunnel/BD even when the tunnel is not added as a member of the bridge domain. This can

cause issues when the VxLAN tunnel is added to the BD on one side but not on the other side.

- VE as Static VxLAN Underlay: VE (Virtual Ethernet) is not supported as a static VxLAN underlay.
- Recommendation: Physical interface or Port-channel used as underlay for VxLAN tunnel should not be part of any Bridge-domain or sub-interface configuration.

Event Log Messages

The system generates log messages for tunnel operational status changes. The log messages indicate when a tunnel becomes operationally down or up, providing valuable information for monitoring and troubleshooting the tunnel status:

- Tunnel Down: interface-mgr[7]: Level:info LogID:25014 Msg:Interface tunnel ISL_10.7.8.7 Operationally DOWN
- Tunnel Up: interface-mgr[7]: Level:info LogID:25013 Msg:Interface tunnel ISL_10.7.8.7 Operationally UP

Configure Static VxLAN

NVE should be configured with a valid IPv4 or IPv6 address and associated with a VRF.

NVO should be configured with NVE, VNI domain, and split horizon group. Tunnels will not come up if any of these configurations are missing.

Configuring Network Virtualization Overlay (NVO)

NVO defines a logical group of VxLAN tunnels that belong to the same IP fabric domain. To configure NVO, follow these steps:

1. Create NVO

```
DUT1(config-overlay)# nvo base
```

2. Associate NVE

```
DUT1(config-nvo-base)# member nve base
```

3. Associate VNI Domain

```
DUT1(config-nvo-base)# member vni-domain base
```

4. Configure Split Horizon Group

```
DUT1(config-nvo-base)# split-horizon group1
```

Configuring Network Virtualization Endpoint (NVE)

NVE defines the VxLAN tunnel endpoints. To configure NVE, follow these steps:

1. Create NVE

```
DUT1(config-overlay)# nve base
```

2. Specify Loopback Interface

```
DUT1(config-nve-base)# source-interface loopback 1
```

Configuring VNI Domain

VNI domain defines the mapping of bridge domains to VNIs. To configure VNI domain, follow these steps:

1. Create VNI Domain

```
DUT1(config-overlay)# vni-domain base
```

2. Configure Auto-Offset

```
DUT1(config-nve-base)# auto-offset 60000
```

Manual VNI Configuration for Bridge Domain

To override the auto-offset for a specific bridge domain, use the following configuration:

1. Configure Bridge Domain.

```
DUT1(config)# bridge-domain 200
```

2. Configure VNI Mapping.

```
DUT1(config-bd-200)# vni-domain base vni 2000
```

Default VNI Offset Configuration

To configure the default VNI auto-offset, use the following command:

```
DUT1(config-overlay)# default-vni-offset 100000
```

VxLAN Tunnel Configuration

To configure IPv4 or IPv6 VxLAN tunnels, follow these steps:

1. Create Tunnel Interface.

```
DUT1(config)# interface tunnel ipv4_tunnel  
Or  
DUT1(config)# interface tunnel ipv4_tunnel
```

2. Specify VxLAN Type.

```
DUT1(config-tun-ip_v4_tunnel)# type vxlan
```

3. Associate NVE.

```
DUT1(config-tun-ip_v6_tunnel)# source nve base
```

4. Specify IPv4 destination IP.

```
DUT1(config-tun-ip_v4_tunnel)# destination 200.200.200.1
```

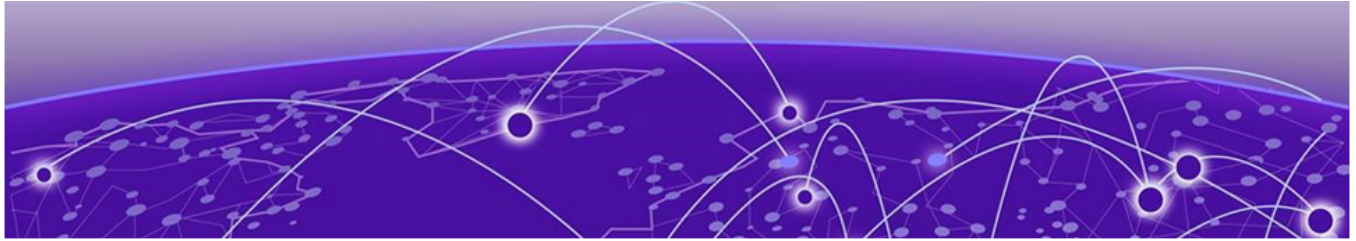

Resilient Hashing

[Static Hashing versus Resilient Hashing in ECMP Routing](#) on page 163

[Key Benefits](#) on page 164

[Limitations](#) on page 164

[Best Practices](#) on page 164

[Impact of Configuration Changes](#) on page 165

[Scalability](#) on page 165

[Configure Resilient Hashing](#) on page 166

[Display ECMP Maximum Paths Route Information for VRFs](#) on page 168

[Logging](#) on page 169

The resilient hashing feature enhances network resilience by intelligently managing traffic flows during topology changes. This reduces service disruption while maintaining optimal path utilization.

Static Hashing versus Resilient Hashing in ECMP Routing

Resilient hashing is a feature that minimizes traffic disruption in equal cost multipath (ECMP) routing when ECMP links fail. Traditional static hashing redistributes all traffic flows when ECMP group membership changes, which might interrupt service. Whereas resilient hashing preserves existing flow mappings to active links when member links fail by permitting traffic redistribution only on failed links.

Static Hashing in ECMP Routing

In traditional ECMP routing, static hashing is used to distribute traffic across multiple paths. This method uses a hash based on packet headers and a subsequent modulo operation based on the number of paths N ($\text{hash} \% N$, where $N = \text{number of paths}$) in the ECMP group.

If a member is added or removed in the ECMP group, because of a modulo number change, the static hashing algorithm might choose a new path for existing flows. When paths change, the modulo value changes to potentially remap all existing flows to different paths. The change in the mapping of the flow might cause traffic disruption.

Resilient Hashing in ECMP Routing

Resilient hashing uses a concept called a *flowset* table of much larger size F . The ECMP path is picked by $(\text{hash} \% F)$, where all existing paths are distributed multiple times to fill the table. When a path fails, only those flows specifically mapped to that path require redistribution, while flows on remaining active paths stay intact.

This approach ensures that existing flows are not remapped when links change. The resilient hashing flowset table maintains flow consistency, even when links are added or removed.

Key Benefits

Resilient hashing provides several key advantages:

- Minimizes traffic disruption: Preserves existing flow mappings when ECMP members change
- Reduces convergence time: Limits redistribution to only affected flows
- Maintains service quality: Prevents unnecessary flow remapping that could impact latency-sensitive applications
- Improves network stability: Reduces the impact of link failures by using a flowset table to maintain flow consistency and ensures that existing flows are preserved even when links are added or removed

Limitations

The resilient feature has the following limitations:

- Protocol next hop changes: Resilient hashing does not protect against explicit ECMP path changes directed by routing protocols. When protocols modify the next-hop set directly, complete path reprogramming occurs.
- Resource sharing: The Extreme 8520, Extreme 8720, and Extreme 8730 platforms share ECMP physical tables between normal and resilient hashing modes, which potentially limits scale.

Best Practices

The following list describes the configuration and operational best practices for the resilient hashing feature:

- Configure appropriately: Enable resilient hashing only on VRFs requiring flow stability during convergence events.
- Monitor resources: On the Extreme 8520, Extreme 8720, and Extreme 8730 platforms, monitor ECMP table usage to ensure sufficient resources for both normal and resilient hashing mode operations.
- Plan capacity: On the Extreme 8520, Extreme 8720, and Extreme 8730 platforms, consider the 50 percent resource limitation when designing network topology.

Impact of Configuration Changes

Changing your resilient hashing configuration affects the system in the following ways:

- Enabling or disabling resilient hashing: Triggers complete next-hop group reprogramming for all affected routes
- Changes to the **ecmp-max-path** setting: Causes route and next-hop group re-installation
- Path sorting: The system sorts protocol next-hops in increasing IP address order when trimming paths beyond the **ecmp-max-path** setting

Scalability

The scalability of resilient hashing differs among the platforms supported by Extreme OS ONE Switching and Routing.

Extreme 8520, Extreme 8720, and Extreme 8730 Platforms

These platforms share an ECMP resource physical table between normal mode ECMP groups and resilient-hashing ECMP groups. Therefore, Extreme OS ONE Switching and Routing restricts physical table capacity to 50 percent, beyond which resilient hashing is treated as normal mode ECMP creation. Normal mode ECMP operations have no cap.

Unlike the Extreme 8520 and Extreme 8720 platforms, the Extreme 8730 platform does not have native hardware support for resilient hashing. Instead, resilient hashing is implemented in software on this platform.

[Table 7](#) shows the ECMP member and group scalability for the Extreme 8520, Extreme 8720, and Extreme 8730 platforms.

Table 7: ECMP member and group scalability for the Extreme 8520, Extreme 8720, and Extreme 8730 platforms

Platform	Max ECMP groups (normal mode)	Max ECMP groups (RH mode)	Max ECMP members (normal mode)	Max ECMP members (RH mode)
Extreme 8520	2,000	256	16,000	16,000
Extreme 8720	2,000	256	16,000	16,000
Extreme 8730	4,000	256	32,000	16,000

Extreme 8820 Platform

This platform uses a dedicated hash-mapping table for resilient hashing. In other words, it does not share an ECMP resource physical table between normal mode ECMP groups and resilient-hashing ECMP groups. Therefore, Extreme OS ONE Switching and Routing does not restrict physical table capacity on this platform.

On this platform, resilient hashing is implemented in hardware.

[Table 8](#) shows the ECMP member and group scalability for the Extreme 8820 platform.

Table 8: ECMP member and group scalability for the Extreme 8820 platform

Max ECMP group size	Max ECMP group number	Max ECMP table size
16 (small)	256 (small)	256 (small)
64 (medium)	64 (medium)	64 (medium)
256 (large)	32 (large)	32 (large)

Configure Resilient Hashing

The system provides various CLI commands to configure and display the ECMP and resilient hashing settings. You configure the maximum number of ECMP paths globally (applies to all VRFs unless overridden) or per VRF.

Configure ECMP Maximum Paths

The maximum number of ECMP paths are configured globally or per VRF. For details on command syntax and parameters, see the *Extreme OS ONE SR Command Reference Guide*.

The system applies the resilient hashing maximum paths setting in the following priority order:

1. VRF-specific **ecmp-max-path** setting (highest priority)
2. Global **ecmp-max-path** setting
3. System default setting (eight paths)

Configuring ECMP Maximum Paths Globally

To configure system-level ECMP maximum paths to a nondefault value:

1. Access global configuration mode.

```
device# configure terminal
```

2. Enter system configuration mode.

```
device(config)# system
```

3. Enter global system configuration mode.

```
device(config-system)# global
```

4. Set the maximum ECMP paths. Use an integer from 2 to 128 (power of 2).

```
device(config-system-global)# ecmp-max-path 64
```

5. (Optional) Verify the configuration.

```
device(config-system-global)# do show running-config system global
```

```
system
  global
    ecmp-max-path 64
  !
```

```
!  
device(config-system-global)#
```

Configuring ECMP Maximum Paths on a VRF

The default for a VRF is eight paths. Changing the default configuration takes effect immediately for all routes in the VRF.

To configure VRF-level ECMP maximum paths to another value:

1. Access global configuration mode.

```
device# configure terminal
```

2. Specify the VRF name and enter VRF configuration mode.

```
device(config)# vrf vrf1
```

3. Set the maximum ECMP paths on the VRF. Use an integer from 2 to 128 (power of 2).

```
device(config-vrf-vrf1)# ecmp-max-path 32
```

4. (Optional) Verify the configuration.

```
device(config-vrf-vrf1)# do show running-configuration vrf vrf1  
  
vrf vrf1  
    ecmp-max-path 32  
!  
device#
```

Enable Resilient Hashing on a VRF

You enable or disable resilient hashing on a per-VRF basis. Resilient hashing is available for the default VRF as well as user-created VRFs.

Follow this procedure to configure resilient hashing on a VRF:

1. Access global configuration mode.

```
device# configure terminal
```

2. Specify the VRF name and enter VRF configuration mode.

```
device(config)# vrf vrf1
```

You can specify the default VRF (named default-vrf) or a user-created VRF.

3. Enable resilient hashing on the VRF.

```
device(config-vrf-vrf1)# resilient-hash
```

4. (Optional) Verify the configuration.

```
device(config-vrf-vrf1)# do show running-configuration vrf vrf1  
  
vrf vrf1  
    ecmp-max-path 32  
    resilient-hash  
!  
device#
```

Display ECMP Maximum Paths Route Information for VRFs

The **show ipv4 route vrf all** and **show ipv6 route vrf all** commands display route information for all VRFs, including resilient hashing status and maximum ECMP paths settings. For details on command syntax and parameters, see the *Extreme OS ONE SR Command Reference Guide*.

The following example displays IPv4 routing table information for a VRF instance named vrf1:

```
device# show ipv4 route vrf vrf1

VRF:vrf1
-----
Resilient Hash: Enabled
Ecmp Max Path: 32
device#
```

The following example displays IPv4 routing table information for all VRF instances:

```
device# show ipv4 route vrf all

VRF:mgmt-vrf
-----
Total number of IPv4 routes: 3, Max Routes: Not Set
'[x/y]' denotes [preference/metric]
0.0.0.0/0, static, [1/1], tag 0, 4hlm47s
192.0.2.0/24, attached, [0/0], tag 0, 4hlm47s
192.0.2.20/32, local, [0/0], tag 0, 4hlm47s

VRF:vrf1
-----
Resilient Hash: Enabled
Ecmp Max Path: 32

VRF:default-vrf
-----
Resilient Hash: Disabled
Ecmp Max Path: 8
device#
```

The following example displays IPv6 routing table information for a VRF instance named vrf1:

```
device# show ipv6 route vrf vrf1

VRF:vrf1
-----
Resilient Hash: Enabled
Ecmp Max Path: 32
device#
```

The following example displays IPv6 routing table information for all VRF instances:

```
device# show ipv6 route vrf all

VRF:mgmt-vrf
-----
Total number of IPv6 routes: 1, Max Routes: Not Set
'[x/y]' denotes [preference/metric]
::/0, dhcp, [0/1024], tag 0, 3h58m23s
```

```
VRF:vrf1
-----
Resilient Hash: Enabled
Ecmp Max Path: 32

VRF:default-vrf
-----
Resilient Hash: Disabled
Ecmp Max Path: 8
device#
```

The following example displays IPv4 routing table information for the management VRF instance:

```
device# show ipv4 route vrf mgmt-vrf

VRF:mgmt-vrf
-----
Total number of IPv4 routes: 3, Max Routes: Not Set
'[x/y]' denotes [preference/metric]
0.0.0.0/0, static, [1/1], tag 0, 4h1m47s
192.0.2.0/24, attached, [0/0], tag 0, 4h1m47s
192.0.2.20/32, local, [0/0], tag 0, 4h1m47s
device#
```

The following example displays IPv4 routing table information for the default VRF instance:

```
device# show ipv4 route vrf default-vrf

VRF:default-vrf
-----
Resilient Hash: Disabled
Ecmp Max Path: 8
device#
```

Logging

The system generates logs for various events related to resilient hashing and ECMP configuration. These logs can be used to troubleshoot issues and monitor system behavior.

Following are several examples of logging:

- ECMP max path configuration: Logs show when the maximum ECMP path configuration is processed, including additions and deletions.
- Resilient hash configuration: Logs indicate when resilient hashing is enabled or disabled on a VRF.
- Dropping ECMP paths: Logs show when ECMP paths are dropped when the maximum path limit is exceeded.
- Encoding maximum ECMP path and resilient hashing: Logs indicate when the maximum ECMP path and resilient hashing information is encoded for HAL.