



AP-7622 Access Point

Installation Guide

Copyright © 2017 Extreme Networks, Inc. All Rights Reserved.

Legal Notices

Extreme Networks, Inc. reserves the right to make changes in specifications and other information contained in this document and its website without prior notice. The reader should in all cases consult representatives of Extreme Networks to determine whether any such changes have been made.

The hardware, firmware, software or any specifications described or referred to in this document are subject to change without notice.

Trademarks

Extreme Networks and the Extreme Networks logo are trademarks or registered trademarks of Extreme Networks, Inc. in the United States and/or other countries.

All other names (including any product names) mentioned in this document are the property of their respective owners and may be trademarks or registered trademarks of their respective companies/owners.

For additional information about Extreme Networks trademarks, go to:

www.extremenetworks.com/company/legal/trademarks/

Support

For product support, phone the Global Technical Assistance Center (GTAC) at 1-800-998-2408 (toll-free in U.S. and Canada) or +1-408-579-2826. For the support phone number in other countries, visit: www.extremenetworks.com/support/contact/

For product documentation online, visit: www.extremenetworks.com/documentation/

Contents

- Introduction 3**
 - Warnings 3
 - Site Preparation 3
 - AP-7622 Package Contents 3
 - Features 3
 - AP-7622 Antennas 4

- Hardware Installation 5**
 - Installation Instructions 5
 - Precautions 5
 - Access Point Placement 6
 - Power Injector System 6
 - Mounting Instructions 8
 - Wall Mount Procedure 8
 - Ceiling Mount Instructions 10
 - AP-7622 Beam Clip 11
 - LED Indicators 12

- Basic Configuration..... 15**

- AP-7622 Access Point Specifications 19**
 - Electrical Characteristics 19
 - Physical Characteristics 19
 - Radio Characteristics 19

- Regulatory Information 21**
 - Regulatory Information 21
 - Bluetooth® Wireless Technology 21
 - Wireless Device Country Approvals 21
 - Declaration of Conformity in Languages of the European Community 22
 - Country Selection 22
 - Country Roaming 22
 - Ad-Hoc Operation (2.4 GHz band) 22
 - Frequency of Operation - FCC and IC 22
 - 5 GHz Only 22
 - 2.4 GHz Only 22
 - Health and Safety Recommendations 23
 - Pacemakers 23
 - Persons with Pacemakers 23
 - Other Medical Devices 24
 - RF Exposure Guidelines 24
 - Safety Information 24
 - Reducing RF Exposure - Use Properly 24
 - Access Points 24

Power Supply	24
Radio Frequency Interference Requirements—FCC	25
Radio Transmitters (Part 15)	25
Radio Frequency Interference Requirements - Canada	25
CE Marking and European Economic Area (EEA)	26
Statement of Compliance	27
Japan (VCCI) - Voluntary Control Council for Interference Class B ITE	27
Korea Warning Statement for Class B ITE	27
Other Countries	27
Australia	28
Brazil (UNWANTED EMISSIONS - ALL PRODUCTS)	28
Chile	28
China	29
Eurasian Customs Union	29
Hong Kong	29
Mexico	29
South Korea	30
Turkey	30
Thailand	30
Taiwan	31
European Waste Electrical and Electronic Equipment (WEEE) Notice	31
Turkish WEEE Statement of Compliance	32
AP-7622 RoHS Compliance	32

1 Introduction

The Access Point's unique WiNG 5 software enables the Access Point to function as either a Standalone Access Point, an Adaptive Access Point or a Virtual Controller.

If new to Access Point technology, refer to the WiNG Access Point System Reference Guide to familiarize yourself with the feature set supported by the WiNG operating system.

This document is written for the qualified network device installer.

Warnings

- Read all installation instructions and site survey reports, and verify correct equipment installation before connecting the Wireless Wallplate.
- Remove jewelry and watches before installing this equipment.
- Verify any device connected to this unit is properly wired and grounded.
- Verify there is adequate ventilation around the device, and that ambient temperatures meet equipment operation specifications.

Site Preparation

- Consult your site survey and network analysis reports to determine specific equipment placement, power drops, and so on.
- Assign installation responsibility to the appropriate personnel.
- Identify and document where all installed components are located.
- Ensure adequate, dust-free ventilation to all installed equipment.
- Identify and prepare Ethernet connections.
- Verify cable lengths are within the maximum allowable distances for optimal signal transmission.

AP-7622 Package Contents

An AP-7622 Access Point is available in internal antenna (AP-7622) configurations. An AP-7622 ships with the following:

- AP-7622 Access Point
- AP-7622 Quick Install Guide

Features

An AP-7622 Access Point supports the following feature set:

- One RJ-45 connector (GE1)
- One RJ-45 console port (Console)
- Three LED indicators (2.4GHz, 5GHZ and BLE)

- One 2.4 GHz 802.11n radio and one 5 GHz 802.11ac radio

The GE1/POE accepts 802.3at or 802.3af compliant power from an external source.

**NOTE**

When operating in a Gigabit Ethernet environment, CAT-5e or CAT-6 cable is recommended for Gigabit operation.

AP-7622 Antennas

An AP-7622 internal antenna Access Point supports the following:

2.4 GHz Gain (dBi)	5 GHz Gain (dBi)
3.64dBi	5.77dBi

2 Hardware Installation

Installation Instructions

An AP-7622 Access Point mounts either on a wall or on a suspended ceiling T-Bar. To prepare for the installation:

To prepare for the installation:

- 1 Match the part number on the purchase order with the part numbers in the packing list and on the case of the Access Point.
- 2 Verify the contents of the box include the intended AP-7622 Access Point, and the included hardware matches the package contents.

Part Number	Description
AP-7622-68B30-US	802.11ac dual band radio 1x1; or single band radio 2x2, internal antenna, BLE, 1xGE (US only)
AP-7622-68B30-1-WR	802.11ac dual band radio 1x1; or single band radio 2x2, internal antenna, BLE, 1xGE (WR)

- 3 Review site survey and network analysis reports to determine the location and mounting position for the AP-7622 Access Point.
- 4 Connect a CAT-5 or better Ethernet cable to a compatible 802.3at or 802.3af power source and run the cable to the installation site. Ensure there is sufficient slack on the cable to perform the installation steps.



NOTE

When operating in a Gigabit Ethernet environment, CAT-5e or CAT-6 cable is recommended for Gigabit operation.

Precautions

Before installing an AP-7622 Access Point, verify the following:

- You are using the correctly rated power solution for the AP-7622 (either the power injector or the external power supply)

AP-PSBIAS-2P3-ATR	PWR INJECTOR: SINGLE PORT HI-PWR 802.3AT
PWR SPLY:100-240 VAC, 12VDC, 1.0A min, 2.5mm barrel, center positive, maximum operating temperature at least 40°C	AC/DC Power Supply

- Do not to install the AP-7622 in wet or dusty areas.
- Verify the environment has a continuous temperature range between 32° F to 104° (0-40°C).
- This product is intended for indoor use only.

Access Point Placement

For optimal performance, install the Access Point away from transformers, heavy-duty motors, fluorescent lights, microwave ovens, refrigerators and other industrial equipment. Signal loss can occur when metal, concrete, walls or floors block transmission. Install the Access Point in an open area or add Access Points as needed to improve coverage.

Antenna coverage is analogous to lighting. Users might find an area lit from far away to be not bright enough. An area lit sharply might minimize coverage and create dark areas. Uniform antenna placement in an area (like even placement of a light bulb) provides even, efficient coverage.

Install the Access Point at an ideal height of 10 feet from the ground.

To maximize the Access Point's radio coverage area, recommends conducting a site survey to define and document radio interference obstacles before installing the Access Point.

Power Injector System

An AP-7622 Access Point can receive power via an Ethernet cable connected to the GE1/POE (LAN) port.

When users purchase a WLAN solution, they often need to place Access Points in obscure locations. In the past, a dedicated power source was required for each Access Point in addition to the Ethernet infrastructure. This often required an electrical contractor to install power drops at each Access Point location. The Power Injector merges power and Ethernet into one cable, reducing the burden of installation and allowing optimal Access Point placement in respect to the intended coverage area.

**CAUTION**

Using a non-compliant injector, or an injector supporting legacy modes will not allow the AP-7622 to function at optimum performance levels.

**CAUTION**

Do not plug the AP-PSBIAS-2P3-ATR Power Injector into the Access Point's Console port. Connecting the Power Injector into the console port can damage the port and void the AP-7622's product warranty.

The AP-PSBIAS-2P3-ATR Power Injector is a high power POE Injector delivering up to 30 watts. The Access Point can only use a Power Injector when connecting the unit to the Access Point's GE1/POE port. The Power Injector is separately ordered and not shipped with an existing AP SKU.

The Access Point's Power Supply is not included with the Access Point and is orderable separately as an accessory. Disconnecting the AC power from the PWRS-14000-148R causes the Access Point to re-boot before sourcing power from the POE power injector. If

the AP is operating using injector supplied power, the AP will not automatically reboot if an AC adapter is connected. The Access Point continues to operate with power supplied from the AC adapter without change to the Access Point operating configuration. If using AC adapter supplied power and a change to the AP's operating configuration is warranted, the Access Point needs to be manually rebooted by the customer.



CAUTION

The Access Point supports any standards-based compliant power source. However, using the wrong solution (including a POE system used on a legacy Access Point) could either limit functionality or severely damage the Access Point and void the product warranty.

A separate Power Injector is required for each AP-7622 Access Point comprising the network.

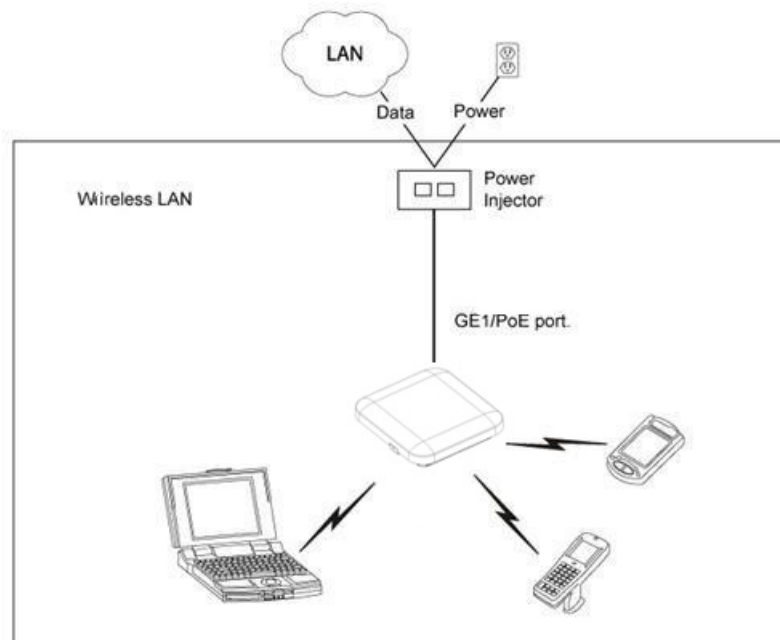

The Power Injector can be installed free standing, on an even horizontal surface or wall mounted using the power injector's wall mounting key holes. The following guidelines should be adhered to before cabling the Power Injector to an Ethernet source and an Access Point:

- Do not block or cover airflow to the Power Injector.
- Keep the Power Injector away from excessive heat, humidity, vibration and dust.

- The Power Injector isn't a repeater, and does not amplify the Ethernet signal. For optimal performance, ensure the Power Injector is placed as close as possible to the data port.

**CAUTION**

To avoid problematic performance and restarts, disable POE from a wired switch port connected to an Access Point if mid-span power sourcing equipment (PSE) is used between the two, regardless of the manufacturer of the switch.

**CAUTION**

Ensure AC power is supplied to the Power Injector using an AC cable with an appropriate ground connection approved for the country of operation.

To install the Power Injector to an Ethernet data source and an Access Point:

- 1 Connect the Power Injector to an AC outlet (100VAC to 240VAC).
- 2 Connect an RJ-45 Ethernet cable between the Power Injector **Data & Power Out** connector and the Access Point's GE1/POE port.
- 3 Connect an RJ-45 Ethernet cable between the network data supply (host) and the Power Injector **Data In** connector.

Ensure the cable length from the Ethernet source (host) to the Power Injector and Access Point does not exceed 100 meters (333 ft).

The Power Injector has no On/Off power switch. The Injector receives power and is ready for device connection and operation as soon as AC power is applied. Refer to the Installation Guide shipped with the Power Injector for a description of its LEDs.

Mounting Instructions

An AP-7622 can be mounted to a flat wall surface or on a T-Bar of a suspended ceiling.

**NOTE**

Before wall mounting the AP-7622, obtain the unit's default IP address from the backside of the unit. This default IP address is needed when connecting to the Access Point.

Wall Mount Procedure

To wall mount an AP-7622 model Access Point:

- 1 Measure and mark two holes 89mm (3.5") apart at the intended deployment orientation of the unit.

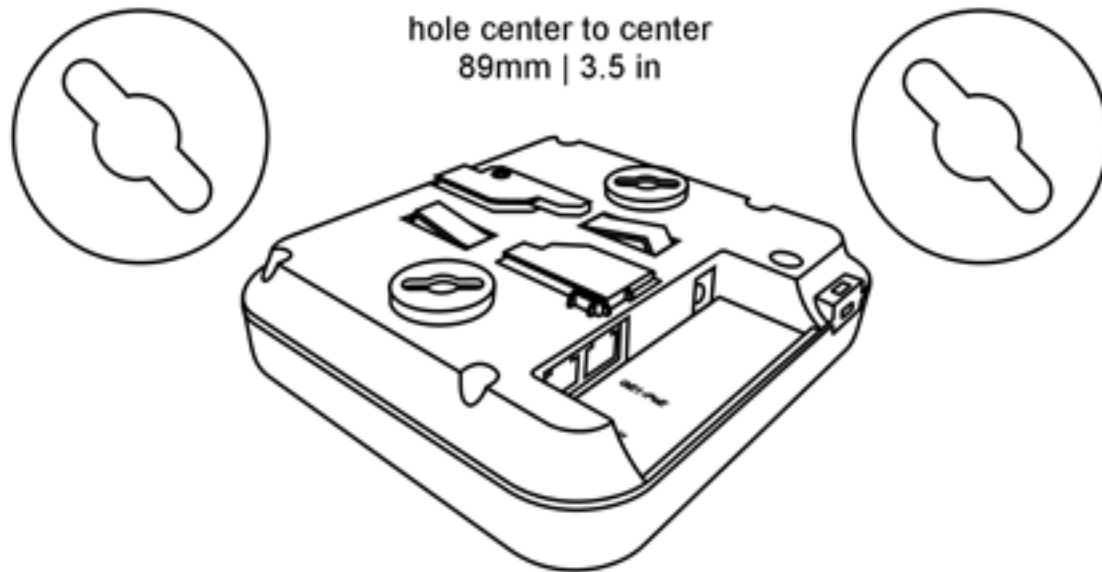
**NOTE**

When pre-drilling a hole the recommended hole size is 4mm (0.16in.).

- 2 Drill pilot holes at the locations marked on the wall.
- 3 Cable the Access Point using the Power Injector solution, approved AP-7622 power supply or a POE enabled switch.

For Power Injector installations:

 - a Connect a RJ-45 CAT5e (or CAT6) Ethernet cable between the Power Injector Data & Power Out connector and the Access Point's GE1/POE port.
 - b Connect a RJ-45 CAT5e (or CAT6) Ethernet cable between the network data supply (host) and the Power Injector Data In connector.
 - c Ensure the cable length from the Ethernet source (host) to the Power Injector and Access Point does not exceed 100 meters (333 ft). The Power Injector has no On/Off power switch. The Power Injector receives power as soon as AC power is applied.

For standard power adapter (non Power Injector) and line cord installations:

 - a Connect a RJ-45 Ethernet cable between the network data supply (host) and the Access Point's GE1/POE port.
 - b Connect the power supply line cords to the power adapter.
 - c Attach the power adapter cable into the power connector on the Access Point.
 - d Attach the power supply line cord to a power supply.

**NOTE**

Extreme Networks recommends wrapping the auxiliary power adapter cable around the Access Point's cable hook to avoid accidental disconnection.

- 4 Verify the Access Point is receiving power by observing the LEDs are lit or flashing.
- 5 Secure the AP-7622 to the wall using oval head screws.
- 6 The Access Point is ready to configure.

Ceiling Mount Instructions

A ceiling mount requires holding the AP-7622 up against a T-Bar of a suspended ceiling grid and twisting the unit on to the T-Bar. If deploying the AP-7622 on a sculpted ceiling T-Bar, the Access Point mounting kit (Part No. KT-135628-01) can be used as well. A beam clip is also available to attach the Access Point to a ceiling beam. A metal clip (Ordering Part No. 37210) is also available to attach the access point to a solid surface.



NOTE

Before mounting the AP-7622 on a ceiling, obtain the unit's default IP address from the backside of the unit. This default IP address is needed when connecting to the Access Point.

- 1 Align (but do not permanently secure) the Access Point's integrated mounting bracket on the T-Bar.
- 2 Cable the Access Point using the Power Injector solution, approved AP-7622 power supply or a POE enabled switch.

For Power Injector installations:

 - a Connect a RJ-45 CAT5e (or CAT6) Ethernet cable between the network data supply (host) and the Power Injector **Data In** connector.
 - b Connect a RJ-45 CAT5e (or CAT6) Ethernet cable between the Power Injector **Data & Power Out** connector and the Access Point's GE1/POE port.
 - c Ensure the cable length from the Ethernet source (host) to the Power Injector and Access Point does not exceed 100 meters (333 ft). The Power Injector has no On/Off power switch. The Power Injector receives power as soon as AC power is applied.

For standard power adapter (non Power Injector) and line cord installations:

 - a Connect a RJ-45 Ethernet cable between the network data supply (host) and the Access Point's GE1/POE port.
 - b Connect the power supply line cords to the power adapter.
 - c Attach the power adapter cable into the power connector on the Access Point.
 - d Attach the power supply line cord to a power supply.



NOTE

Extreme Networks recommends wrapping the auxiliary power adapter cable around the Access Point's cable hook to avoid accidental disconnection.

- 3 Verify the unit has power by observing the LEDs.
- 4 Orient the Access Point chassis by its length and the length of the ceiling T-Bar.
- 5 Rotate the Access Point chassis 45 degrees clockwise.
- 6 Push the back of the Access Point chassis on to the bottom of the ceiling T-Bar.

- 7 Rotate the Access Point 45 degrees counter-clockwise. The clips click as they fasten to the T-Bar.

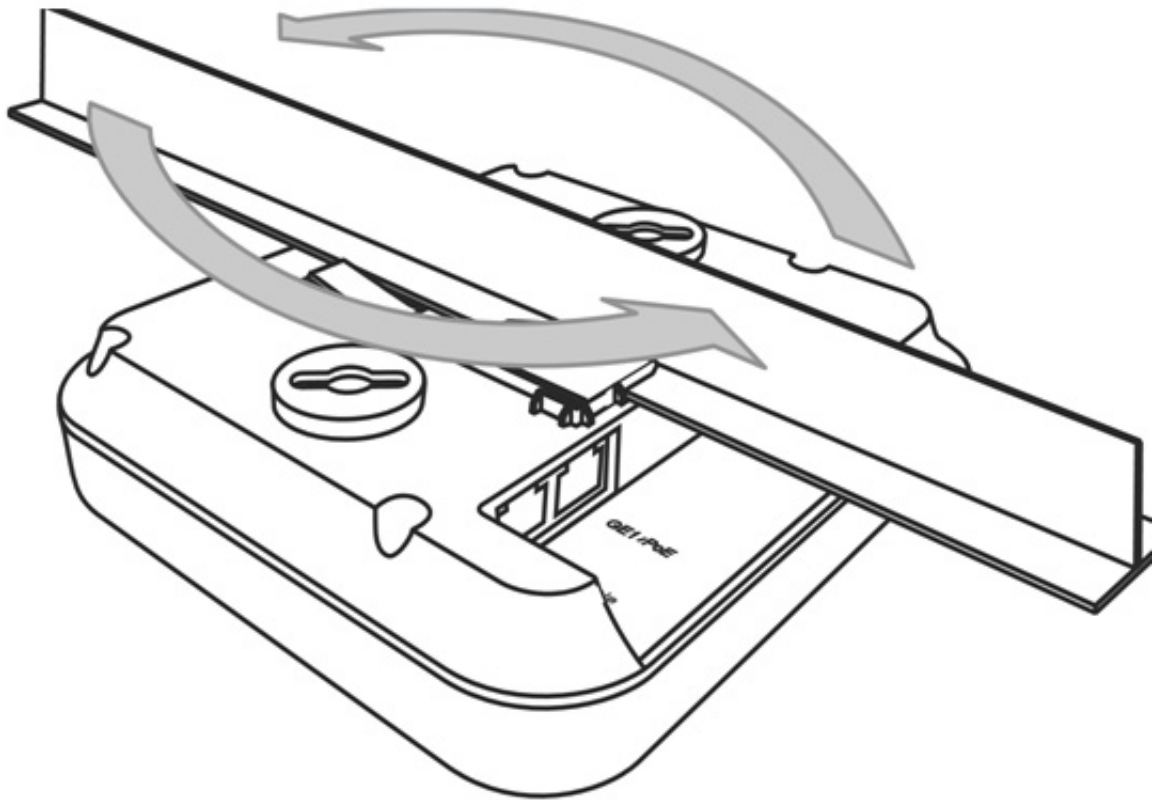

- 8 The Access Point is ready to configure.

AP-7622 Beam Clip

When needed, an AP-7622 can also be ceiling mounted using a beam clip.



If utilizing a beam clip, attach the beam clip to the AP-7622's integrated mounting bracket. Then connect the Access Point to the ceiling beam.

LED Indicators

The AP-7622's three LED activity indicators are located on the front of the housing and are visible through the enclosure.

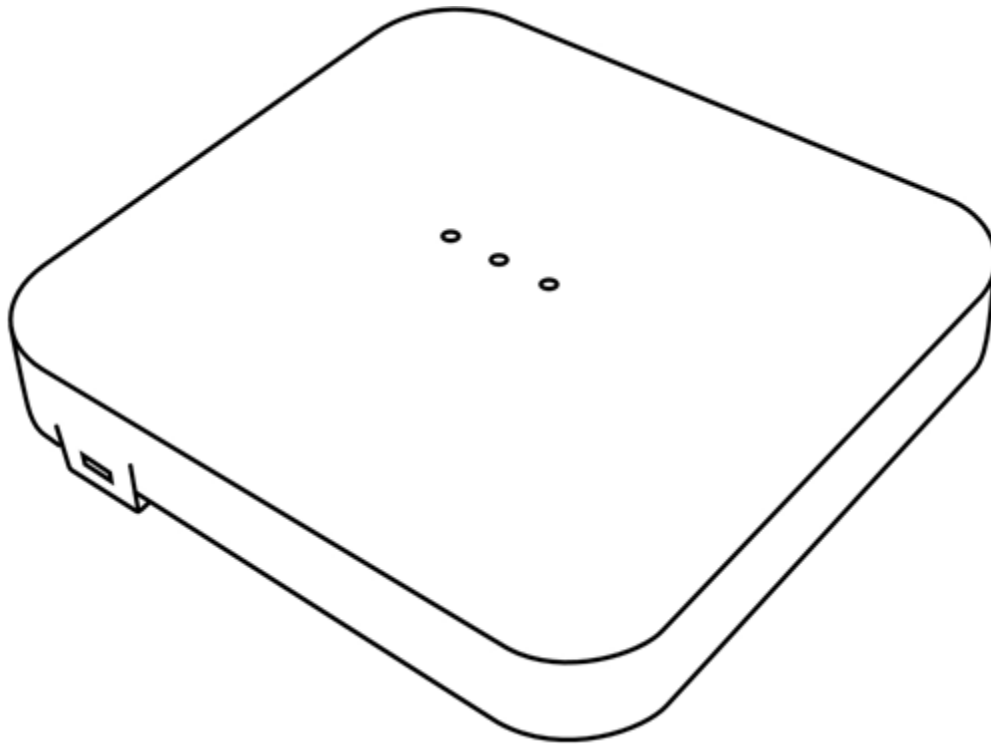

The LEDs provide a status display indicating error conditions, transmission, and network activity for the 5 GHz 802.11ac (amber) radio, 2.4 GHz 802.11n (green) radio and Bluetooth activity (blue) radio.



NOTE

LED behavior for the AP-7622 are identical in both WLAN and client bridge modes.

Task	Green	Amber	Blue
Firmware Update	Off	On	Off
Radio Disabled	Off	Off	N/A
Radio Enabled Not Configured	Solid Green	Solid Amber	N/A
Radio Enabled and Configured	Blink 500ms Out of sync with Amber LED	Blink 500ms Out of sync with Green LED	N/A

Task	Green	Amber	Blue
Sensor with Server Connected	On 1 second, Off 1 second Synced with Amber LED	On 1 second, Off 1 second Synced with Green LED	N/A
Sensor with Server Not Connected	On 1 second, Off 5 seconds Synced with Amber LED	On 1 second, Off 5 seconds Synced with Green LED	N/A
Locate AP Mode	Irregular Blink Rate, Green/Amber/Blue	Irregular Blink Rate, Green/Amber/Blue	Irregular Blink Rate, Green/Amber/Blue
Bluetooth Radio Enabled	N/A	N/A	Solid Blue
Bluetooth Radio Disabled	N/A	N/A	Off



3 Basic Configuration

Once the Access Point is installed and powered on, complete the following WiNG Assist configuration steps to get the Access Point up and running with minimal administrative intervention.

Startup Assist updates existing settings. To delete or revise existing Startup Assist settings, either rerun Startup Assist or navigate to where those parameters appear in the user interface and update them accordingly. Refer to the Access Point's more advanced configuration documentation available on the Extreme Networks support site for updating the management interface beyond the scope of the WiNG Assist configuration described in this guide.

- 1 Power the AP-7622 using an appropriate power adapter, PoE injector, or PoE switch.
- 2 Connect to the AP-7622. The default IP address is located on the backside of the AP-7622.

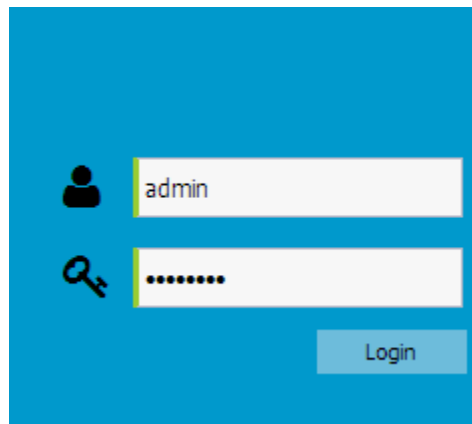

- 3 Enter the default username `admin` in the **Username** field.
- 4 Enter the default password `admin123` in the **Password** field.
- 5 Select the **Login** button to load the management interface.

If logging in using a factory default configuration, Startup Assist automatically displays.

If Startup Assist does not automatically display, it can be invoked at any time from the upper-left of the **Basic Configuration** screen.



NOTE

Startup Assist automatically sets the radio transmit power and enables Auto Channel selection. The Access Point's name is automatically assigned based on the Access Point type and the last three octets of the device's hard coded MAC address. WLAN 1 and WLAN 2 both use VLAN ID 2200 by default. To adjust any of these parameters, edit the appropriate configuration screen directly. Refer to the Access Point reference material available on Extreme Networks support site for configuring the Access Point beyond the scope of the minimal WiNG Assist configuration described in this guide.

- 6 Set the following Startup Assist parameters:
 - **Virtual Controller** - Sets this Access Point as a Virtual Controller capable of managing and provisioning up to 24 Access Points of the same model. Access Points managed by this Virtual Controller list this Access Point's AP Name as its own. Only one Virtual Controller can be designated.
 - **Country Name** - Set the country specific to this AP-7622's deployment location. Selecting the correct country is central to legal operation. Each country has its own

regulatory restrictions concerning electromagnetic emissions and the maximum RF signal strength that can be transmitted.

**NOTE**

Country Name can not be changed when deployed in the United States or Canada.

- **Timezone** - Use the drop-down menu to specify the geographic timezone where the AP-7622 is deployed. Different geographic time zones have daylight savings clock adjustments, so specifying the timezone correctly is important to account for geographic time changes.
 - **Date & Time** -Set the date, hour and minute for the AP-7622's current system time. Specify whether the current time is in the AM or PM.
 - **WLAN 1 Name** - Provide a unique name for this WLAN as its network identifier. This is a required setting. The name is used for the SSID and is assigned to both of the AP-7622's radios.
 - **Authentication** - Select PSK to apply a 64 character maximum passphrase. Provide the passphrase in either ASCII or Hex format. The authenticating device must use the same PSK algorithm during authentication. Selecting **Show** displays the key in exposed plain text (not recommended).
 - Selecting **Open** is not a recommended authentication scheme, as it would provide the Access Point's WLAN no security via credential exchange and would only make sense in a network where no sensitive data is either transmitted or received.
- 7 Select **Apply** to save and commit the Startup Assist changes to the AP-7622's configuration. Select **Discard** to revert to the last saved configuration.

The **Virtual Controller**, **Country Name**, **Timezone** and **Date & Time** portions of the Basic Settings screen update with the settings applied and saved in the Startup Assist screen. WLAN updates made in Startup Assist are displayed in Wireless screen, not the Basic Configuration screen.

4 AP-7622 Access Point Specifications

Electrical Characteristics

An AP-7622 has the following electrical characteristics:

Operating Current & Voltage	12VDC, 1A, 2.5mm barrel connector, center positive
Power over Ethernet	48VDC, .25A, PoE

Physical Characteristics

An AP-7622 Access Point has the following physical characteristics:

Dimensions	7.1 in. L x 6.5 in. W x 1.6 in. H 180 mm L x 165 mm W x 41 mm H
Weight	0.85 lbs/0.385 kg
Operating Temperature	32° F to 104° F/0° C to 40° C
Storage Temperature	-40° F to 158° F/-40° C to 70° C
Operating Humidity	85% RH non-condensing
Operating Altitude (maximum)	8,000 ft @ 28C
Storage Altitude (maximum)	30,000 ft
Electrostatic Discharge	15KV air, 8KV contact

Radio Characteristics

An AP-7622 Access Point has the following radio characteristics:

Data Rates Supported	802.11b/g: 1,2,5.5,11,6,9,12,18,24,36,48 and 54 Mbps 802.11a: 6,9,12,18,24,36,48, and 54 Mbps 802.11n: MCS 0-15 up to 300 Mbps 802.11ac: MCS 0-9 up to 866.7 Mbps
Wireless Medium	Direct Sequence Spread Spectrum (DSSS) Orthogonal Frequency Division Multiplexing (OFDM)
Network Standards	IEEE 802.11a/b/g/n/ac 802.11d and 802.11i WPA2 WMM and WMM-UAPSD
Transmit Power Adjustment	1dB increments

5 Regulatory Information

Regulatory Information

This guide applies to the following Model Number AP-7622.

Extreme Networks devices are designed to be compliant with rules and regulations in locations they are sold and will be labeled as required.

Local language translations are available at the following Website:
www.extremenetworks.com/support

Any changes or modifications to Extreme Networks equipment, not expressly approved by Extreme Networks could void the user's authority to operate the equipment.

Extreme Networks devices are professionally installed, the Radio Frequency Output Power will not exceed the maximum allowable limit for the country of operation.

Antennas: Use only the supplied or an approved replacement antenna. Unauthorized antennas, modifications, or attachments could cause damage and may violate regulations.

Bluetooth® Wireless Technology

This is an approved Bluetooth® product. For more information or to view the End Product Listing, please visit <https://www.bluetooth.org/tpg/listings.cfm>.

Wireless Device Country Approvals

Regulatory markings subject to certification are applied to the device signifying the radio(s) is/are approved for use in the following countries and continents: United States, Canada, Japan, China, South Korea, Australia, and Europe.



NOTE

Europe includes, Austria, Belgium, Bulgaria, Czech Republic, Cyprus, Denmark, Estonia, Finland, France, Germany, Greece, Hungary, Iceland, Ireland, Italy, Latvia, Liechtenstein, Lithuania, Luxembourg, Malta, Netherlands, Norway, Poland, Portugal, Romania, Slovak Republic, Slovenia, Spain, Sweden, Switzerland and the United Kingdom.



WARNING

Operation of the device without regulatory approval is illegal.

Declaration of Conformity in Languages of the European Community

Hereby, Extreme Networks, Inc. declares that the radio equipment type Wireless LAN Access Point is in compliance with Directive 1999/5/EC. The full text of the EU declaration of conformity is available at the following Internet address:
<http://www.extremenetworks.com/>

Country Selection

Select only the country in which the device will be used. Any other selection will make the operation of this device illegal.

Country Roaming

This device incorporates the International Roaming feature (IEEE802.11d) which will ensure the product operates on the correct channels for the particular country of use.

Ad-Hoc Operation (2.4 GHz band)

Ad-Hoc operation is limited to Channels 1-11 (2412-2462 MHz).

Frequency of Operation – FCC and IC

5 GHz Only

Industry Canada Statement:

Caution: The device for the band 5150-5250 MHz is only for indoor usage to reduce potential for harmful interference to co-Channel mobile satellite systems. High power radars are allocated as primary users (meaning they have priority) over other frequencies and these could cause interference and/or damage to LE-LAN devices.

Attention: Le dispositif pour la bande 5150-5250 MHz est uniquement destiné à une utilisation en intérieur afin de réduire les brouillages préjudiciables aux systèmes de satellites mobiles co-canaux. Les radars haute puissance sont Alloués en tant qu'utilisateurs principaux (c'est-à-dire qu'ils ont la priorité) par rapport aux autres fréquences et qui pourraient causer des interférences et / ou endommager les dispositifs LE-LAN.

2.4 GHz Only

Available channels for 802.11bg operation in the US are 1 to 11. The range of channels is limited by firmware.

Health and Safety Recommendations



Ergonomic Recommendations



CAUTION

In order to avoid or minimize the potential risk of ergonomic injury follow the recommendations below. Consult with your local Health & Safety Manager to ensure that you are adhering to your company's safety programs to prevent employee injury.

- Reduce or eliminate repetitive motion
- Maintain a natural position
- Reduce or eliminate excessive force
- Keep objects that are used frequently within easy reach
- Perform tasks at correct heights
- Reduce or eliminate vibration
- Reduce or eliminate direct pressure
- Provide adjustable workstations
- Provide adequate clearance
- Provide a suitable working environment
- Improve work procedures

Wireless devices transmit radio frequency energy and may affect medical electrical equipment. When installed adjacent to other equipment, verify that the adjacent equipment is not adversely affected.

Pacemakers

Pacemaker manufacturers recommended that a minimum of 15cm (6 inches) be maintained between a handheld wireless device and a pacemaker to avoid potential interference with the pacemaker. These recommendations are consistent with independent research and recommendations by Wireless Technology Research.

Persons with Pacemakers

- Should ALWAYS keep the device more than 15cm (6 inches) from their pacemaker when turned ON.
- Should not carry the device in a breast pocket.
- Should use the ear furthest from the pacemaker to minimise the potential for interference.

- If you have any reason to suspect that interference is taking place, turn OFF your device.

Other Medical Devices

Please consult your physician or the manufacturer of the medical device to determine if the operation of your wireless product may interfere with the medical device.

RF Exposure Guidelines

Safety Information

Reducing RF Exposure - Use Properly

Only operate the device in accordance with the instructions supplied.

International

The device complies with internationally recognized standards covering human exposure to electromagnetic fields from radio devices.

Access Points

Access Points must conform to U.S. Federal Communications Commission's (FCC) limitations. FCC has now stipulated a 21dBm EIRP limit for power directed 30 degrees above the horizon.

For supplied antennas, compatible with 5.0 GHz on the access points, refer to the Antenna Guide for "Elevation Gain" information. If using a third-party antenna, it is required that you obtain the antenna-elevation gain information from the antenna manufacturer.

Panel antennas and polarized antennas for point to point only are excluded from this requirement.

The elevation gain must be configured if the access point:

- Is used with dipole antenna. and
- Is transmitting in the 5.15 - 5.25 GHz Unlicensed National Information Infrastructure-1 (UNII1) band

Power Supply

Use ONLY an approved UL LISTED ITE (IEC/EN 60950-1, LPS/SELV) power supply with electrical ratings: Output 12Vdc, min 1A, with a maximum ambient temperature of at least 50 degrees C. Use of alternative power supply will invalidate any approvals given to this unit and may be dangerous.

Alternately this device may be powered from a 802.3af compliant power source which has been certified by the appropriate agencies, or by an approved UL LISTED ITE (IEC/EN 60950-1, LPS/SELV) power supply with electrical ratings: Output 48Vdc, min 0.25A, with a

recommended ambient temperature greater than 50 degrees C. Use of alternative power supply will invalidate any approvals given to this unit and may be dangerous.

The product is to be connected to PoE networks without routing to the outside plant.

Radio Frequency Interference Requirements—FCC

This equipment has been tested and found to comply with the limits for a Class B digital device, pursuant to Part 15 of the FCC rules. These limits are designed to provide reasonable protection against harmful interference in a residential installation. This equipment generates, uses and can radiate radio frequency energy and, if not installed and used in accordance with the instructions, may cause harmful interference to radio communications. However there is no guarantee that interference will not occur in a particular installation. If this equipment does cause harmful interference to radio or television reception, which can be determined by turning the equipment off and on, the user is encouraged to try to correct the interference by one or more of the following measures:

- Reorient or relocate the receiving antenna
- Increase the separation between the equipment and receiver
- Connect the equipment into an outlet on a circuit different from that to which the receiver is connected
- Consult the dealer or an experienced radio/TV technician for help.

Radio Transmitters (Part 15)

This device complies with Part 15 of the FCC Rules. Operation is subject to the following two conditions: (1) this device may not cause harmful interference, and (2) this device must accept any interference received, including interference that may cause undesired operation.

The equipment shall be subject to professional engineering personnel to install and configure, it just can be used, and may not be sold directly to the general consumer.

Based on 20cm separation distance to assess the amount of electromagnetic exposure(MPE).

MPE limit $1\text{mW}/\text{cm}^2$; Test result is $0.39207\text{ mW}/\text{cm}^2$

When using this device, it is recommended to have a separation distance of 20 cm.

This transmitter must not be co-located or operating in conjunction with any other antenna or transmitter.

Radio Frequency Interference Requirements - Canada

CAN ICES-3 (B)/NMB-3(B)

Radio Transmitters

This device complies with Industry Canada's licence-exempt RSSs. Operation is subject to the following two conditions: (1) This device may not cause interference; and (2) This device must accept any interference, including interference that may cause undesired operation of the device.

Le présent appareil est conforme aux CNR d'Industrie Canada applicables aux appareils radio exempts de licence. L'exploitation est autorisée aux deux conditions suivantes: (1) l'appareil ne doit pas produire de brouillage, et (2) l'utilisateur de l'appareil doit accepter tout brouillage radio électrique subi même si le brouillage est susceptible d'en compromettre le fonctionnement.

Label Marking: The Term 'IC:' before the radio certification only signifies that Industry Canada technical specifications were met.

Etiquette de marquage: Le terme "IC" avant la certification radio signifie que le produit est compatible avec le spécification Industrie Canada

The equipment shall be subject to professional engineering personnel to install and configure, it just can be used, and may not be sold directly to the general consumer.

Based on 20cm separation distance to assess the amount of electromagnetic exposure

2.4GHz Band: MPE limit 5.4039 W/m²; Test result is 1.5215 W/m²

5GHz Band: MPE limit 9.7564 W/m²; Test result is 2.2977 W/m²

When using this device, it is recommended to have a separation distance of 20 cm.

L'équipement doit être assujetti au personnel d'ingénierie. Configurer, il peut seulement être utilisé, et ne peut pas être vendu directement au consommateur général.

Basé sur une distance de séparation de 20 cm pour évaluer la quantité d'exposition électromagnétique (MPE).

2.4GHz Band: MPE limite 5.4039 W / m²; Le résultat du test est de 1.5215 W / m²

5GHz Band: MPE limite 9.7564 W / m²; Le résultat du test est de 2.2977 W / m²

Lors de l'utilisation de cet appareil, il est recommandé d'avoir une distance de séparation de 20 cm.

This transmitter must not be co-located or operating in conjunction with any other antenna or transmitter.

Cet émetteur ne doit pas être co-implanté ou fonctionner en conjonction avec une autre antenne ou émetteur.

CE Marking and European Economic Area (EEA)

The use of 2.4GHz RLAN's, for use through the EEA, have the following restrictions:

Maximum radiated transmit power of 100 mW EIRP in the frequency range 2.400 -2.4835 GHz.

Bluetooth® Wireless Technology for use throughout the EEA has the following restrictions:

- Maximum radiated transmit power of 100 mW EIRP in the frequency range 2.400 - 2.4835 GHz.

Statement of Compliance

Extreme Networks hereby declares that this radio equipment is in compliance with Directive 2011/65/EU and 1999/5/EC or 2014/53/EU (2014/53/EU supersedes 1999/5/EC from 13th June 2017).

Japan (VCCI) - Voluntary Control Council for Interference Class B ITE

この装置は、クラスB情報技術装置です。この装置は、家庭環境で使用することを目的としていますが、この装置がラジオやテレビジョン受信機に近接して使用されると、受信障害を引き起こすことがあります。

取扱説明書に従って正しい取り扱いをしてください。
VCCI-B

This is a Class B product based on the standard of the Voluntary Control Council for Interference from Information Technology Equipment (VCCI). If this is used near a radio or television receiver in a domestic environment, it may cause radio interference. Install and use the equipment according to the manual.

Korea Warning Statement for Class B ITE

기종별	사용자 안내문
B급 기기 (가정용 방송통신기자재)	이 기기는 가정용(B급) 전자파적합기기로서 주로 가정에서 사용하는 것을 목적으로 하며, 모든 지역에서 사용할 수 있습니다.
Class	User's Guide
Class B (Broadcasting Communication Device for Home Use)	This device obtained EMC registration mainly for home use (Class B) and may be used in all areas.

Other Countries

All 2.4GHz and 5GHz Wireless Devices:

Australia

Use of 5GHz RLAN's in Australia is restricted in the following band 5.50 – 5.65GHz.

Brazil

Este equipamento não tem direito à proteção contra interferência prejudicial e não pode causar interferência em Sistemas devidamente autorizados.

Chile

Este equipo cumple con la Resolución No 403 de 2008, de la Subsecretaria de telecomunicaciones, relativa a radiaciones electromagnéticas.

This device complies with the Resolution Not 403 of 2008, of the Undersecretary of telecommunications, relating to electromagnetic radiation.

Chile: (Devices with a WLAN Radio)

The device will comply with Chile's Resolution 755, part j.1) which states that the device is set to operate in the following bands for indoor use only with maximum radiated power not greater than 150mW:

- 2.400 hasta 2.483,5 MHz
- 5.150 hasta 5.250MHz
- 5.250 hasta 5.350MHz
- 5.725 hasta 5.850MHz

as well as that band 5150-5250MHz will be restricted to the indoor use and the maximum radiated power density does not exceed 7.5mW / MHz in any 1 MHz band and 0.1875mW / 25kHz in any 25kHz band.

Conforme a Resolución 755 parte j.1), se ajustará el dispositivo a operar en interiores en las siguientes bandas con una potencia máxima radiada no superior a 150mW:

- 2.400 hasta 2.483,5 MHz
- 5.150 hasta 5.250MHz
- 5.250 hasta 5.350MHz
- 5.725 hasta 5.850MHz

Además, de acuerdo con Resolución 755, para la banda 5150-5250MHz la operación del equipo estará restringida al interior de inmuebles y la densidad de potencia radiada máxima no supera 7,5mW/MHz en cualquier banda de 1MHz y 0.1875mW/25kHz en cualquier banda de 25kHz.

China

通过访问以下网址可下载当地语言支持的产品说明书 www.extremenetworks.com/support.



Eurasian Customs Union

Евразийский Таможенный Союз

Данный продукт соответствует требованиям знака ЕАС.



Hong Kong

In accordance with HKTA1039, the band 5.15GHz - 5.35GHz is for indoor operation only.

Mexico

La operación de este equipo está sujeta a las siguientes dos condiciones: (1) es posible que este equipo o dispositivo no cause interferencia perjudicial y (2) este equipo o dispositivo debe aceptar cualquier interferencia, incluyendo la que pueda causar su operación no deseada.

South Korea

For a radio equipment using 2400-2483.5MHz or 5725-5825MHz, the following two expressions should be displayed:

무선 설비는 운용 중 전파혼신 가능성이 있음

당해 무선설비는 전파혼신 가능성이 있으므로 인명안전과 관련된 서비스는 할 수 없습니다.

Turkey

For terminals that support Turkish characters in SMS Release 8 services, the following statement should be printed on the packages and manual of the device:

Bu cihaz Türkçe karakterlerin tamamını ihtiva eden ETSI TS 123.038 V8.0.0 (veya sonraki sürümün kodu) ve ETSI TS 123.040 V8.1.0 (veya sonraki sürümün kodu) teknik özelliklerine uygundur.

This device conforms to technical specification in ETSI TS 123.038 V8.0.0 (or the code of any subsequent release) and ETSI TS 123.040 V8.1.0 (or the code of any subsequent release) which contain all Turkish characters.

Thailand

เครื่องโทรคมนาคมและอุปกรณ์นี้ มีความสอดคล้องตามข้อกำหนดของ กทช.

Taiwan

台灣

低功率電波輻射性電機管理辦法

第十二條

經型式認證合格之低功率射頻電機，非經許可，公司、商號或使用者均不得擅自變更頻率、加大功率或變更原設計之特性及功能。

第十四條

低功率射頻電機之使用不得影響飛航安全及干擾合法通信；經發現有干擾現象時，應立即停用，並改善至無干擾時方得繼續使用。

前項合法通信，指依電信規定作業之無線電通信。

低功率射頻電機需忍受合法通信或工業、科學及醫療用電波輻射性電機設備之干擾。

使用此產品時應避免影響附近雷達系統之操作。

無線基地台（專業安裝）

- “本公司於說明書中提供所有必要資訊以指導使用者/安裝者正確的安裝及操作”警語。並於該中文使用說明書及器材上標示。
- “本器材須經專業工程人員安裝及設定，始得設置使用，且不得直接販售給一般消費者”警語。

電磁波曝露量MPE標準值 $1\text{mW}/\text{cm}^2$ ；送測產品實測值為： $0.35473\text{ mW}/\text{cm}^2$

本產品使用時建議應距離人體 20cm

European Waste Electrical and Electronic Equipment (WEEE) Notice



In accordance with Directive 2012/19/EU of the European Parliament on waste electrical and electronic equipment (WEEE):

The symbol above indicates that separate collection of electrical and electronic equipment is required.

When this product has reached the end of its serviceable life, it cannot be disposed of as unsorted municipal waste. It must be collected and treated separately.

It has been determined by the European Parliament that there are potential negative effects on the environment and human health as a result of the presence of hazardous substances in electrical and electronic equipment.

It is the users' responsibility to utilize the available collection system to ensure WEEE is properly treated.

For information about the available collection system, please contact Extreme Customer Support at +353 61 705500 (Ireland).

Turkish WEEE Statement of Compliance

EEE Yönetmeliğine Uygundur

AP-7622 RoHS Compliance

部件名称 (Parts)	有害物质 					
	铅 (Pb)	汞 (Hg)	镉 (Cd)	六价铬 (Cr(VI))	多溴联苯 (PBB)	多溴二苯醚 (PBDE)
金属部件 (Metal Parts)	0	0	0	0	0	0
电路模块 (Circuit Modules)	X	0	0	0	0	0
电缆及电缆组件 (Cables and Cable Assemblies)	0	0	0	0	0	0
塑料和聚合物部件 (Plastic and Polymeric Parts)	0	0	0	0	0	0
光学和光学组件 (Optics and Optical Components)	0	0	0	0	0	0
电池 (Batteries)	0	0	0	0	0	0

本表格依据 SJ/T 11364 的规定编制。

0: 表示该有害物质在该部件所有均质材料中的含量均在 GB/T 26572 规定的限量要求以下。

X: 表示该有害物质至少在该部件的某一均质材料中的含量超出GB/T 26572 规定的限量要求。
(企业可在此处, 根据实际情况对上表中打“×”的技术原因进行进一步说明。)

This table was created to comply with China RoHS requirements for AP-7622 Access Points.