



Enterprise Wireless LAN Antenna Specification Guide

Copyright © 2017 Extreme Networks, Inc. All rights reserved.

Legal Notice

Extreme Networks, Inc. reserves the right to make changes in specifications and other information contained in this document and its website without prior notice. The reader should in all cases consult representatives of Extreme Networks to determine whether any such changes have been made.

The hardware, firmware, software or any specifications described or referred to in this document are subject to change without notice.

Trademarks

Extreme Networks and the Extreme Networks logo are trademarks or registered trademarks of Extreme Networks, Inc. in the United States and/or other countries.

All other names (including any product names) mentioned in this document are the property of their respective owners and may be trademarks or registered trademarks of their respective companies/owners.

For additional information on Extreme Networks trademarks, please see:

www.extremenetworks.com/company/legal/trademarks

Software Licensing

Some software files have been licensed under certain open source or third-party licenses. End-user license agreements and open source declarations can be found at:

www.extremenetworks.com/support/policies/software-licensing

Support

For product support, phone the Global Technical Assistance Center (GTAC) at 1-800-998-2408 (toll-free in U.S. and Canada) or +1-408-579-2826. For the support phone number in other countries, visit: <http://www.extremenetworks.com/support/contact/>

For product documentation online, visit: <https://www.extremenetworks.com/documentation/>

Table of Contents

Preface	8
Text Conventions.....	8
Platform-Dependent Conventions.....	8
Providing Feedback to Us.....	9
Getting Help.....	9
Extreme Networks Documentation.....	10
Chapter 1: Antenna Selection and Description	11
Antenna Selection.....	11
Antenna Selection Criteria.....	15
Antenna Accessories for Enterprise WLANs.....	17
Chapter 2: Product Compatibility	19
FCC Compliance.....	19
FCC Approval Statement.....	20
FCC USA Compatibility Matrix.....	24
Chapter 3: 2.4 GHz Single Band Antenna Suite	35
ML-2499-HPA3-02R Dipole Omni Antenna: RP-SMA Male.....	35
ML-2499-FHPA5-01R Omni-Directional "Pipe" Antenna: N Male Connector.....	37
ML-2499-HPA4-01 Outdoor Dipole Omni Antenna: N Male Connector.....	40
ML-2499-HPA8-01 Outdoor Dipole Omni Antenna: N Male Connector.....	42
RAN405A-01R 802.11BGN, Dipole Omni, DT, 7dBi, LP, N-Type-M.....	43
Chapter 4: 5.2 GHz Single Band Antenna Suite	46
Supported 802.11a/n Antenna Suite.....	46
Chapter 5: 2.4 GHz - 5.2 GHz Dual Band Antenna Suite	56
ML-2452-APA2-01 Indoor Dual Band Elbow Jointed Dipole: RP-SMA Male (Black)	
ML-2452-APA2-02 Indoor Dual Band Elbow Jointed Dipole: RP-SMA Male (White).....	57
ML-2452-PNA5-01R Dual Band Directional Panel: Connector Type N-Male.....	60
ML-2452-PNA7-01R Dual Band Panel: Connector Type N-Male.....	63
ML-2452-PTA2M3X3-1 AP-7131 MIMO Facade: 1 IN, RPSMA.....	65
ML-2452-PTA3M3-036 Ceiling Mount, Dual Band, MIMO Patch: RPSMA.....	68
ML-2452-HPA5-036 Dipole, RP-SMA-Male.....	73
ML-2452-PNL9M3-036 MIMO Dual Band Polarized Panel, RP-SMA Male.....	76
ML-2452-APAG2A1-01 Dipole, RP-SMA Male (Black) ML-2452-APAG2A1-02 Dipole, RP-SMA Male (White).....	80
ML-2452-HPAG4A6-01 Outdoor Dipole Omni N-Male.....	82
ML-2452-HPAG5A8-01 Outdoor Dipole Omni N-Male.....	85
ML-2452-PTA6X6-036 Indoor dual-band MIMO Omni Array, RP-SMA Male.....	88
ML-2452-HPA6X6-036 802.11ABG 6-Port Omni Dipole Array, Type N Male x6.....	90
ML-2452-PTA2M2-036 802.11ABG 2-Port Patch Array, RP-SMA Male.....	95
ML-2452-PTA6M6-036 Six-Port Omnidirectional Panel, RP-SMA Male.....	97
ML-2452-PTA6M6-1 Six-Port Facade Antenna, RP-SMA Male.....	104
ML-2452-HPA6M6-072 11ABGN, 6P DB Omni, 2.0/4.8 dBi, LP, CBL 72, RP -SMA-M.....	111
ML-2452-VMM3M3-036 11ABGN, 3-Port Omni Array, RP-SMA Male x 3.....	118
AP6562 Internal 802.11ABGN, Multi-Element x 2.....	122
AP8222 Internal 802.11ABGN, 6 x PIFA, -1.8 dBi, LP, U.FI.....	126

AP-7522 and AP-7532 Dual-Band Monopole (2.4/5 GHz).....	137
ML-2452-PNL3M3-1 11ABGN, 3-Port Polarized Panel, 9.7/9.2 dBi, DP, Fixed N-Type Female....	140
ML-2452-HPA6-01, 11ABGN, Dipole, N-Type Male.....	144
AP7502 Internal 802.11ABGNac, Dipole Omni x4.....	146
ML-2452-PNL6M3-N36 , 11ABGN, 120° Sector, 3-Port, 6/6 dBi, LP, CBL 36, N-Type-M.....	152
ML-2452-SEC6M3-N36 , 11ABGN, 3-Port, Multi-Pol, Dir Panel, 6.5/5.0 dBi, LP, CBL 36, N-Type-M.....	158
ML-2452-VMM5M3-N72, 11ABGN, 3-Port Dual-Band, Vertical Polarization Omni Array.....	164
ML-2452-PNL9M3-N36, 11ABGN, 3-Port Dual-Band, Dual Polarization Dir Panel2 V-Pol and 1 H-Pol ports.....	171
AP7562 Facade Antenna.....	176
AP8432 Dual-Band Internal Antenna (2.4/5 GHz).....	179
AP8533i Dual-Band Internal Antenna (2.4/5 GHz).....	183
AP7602 Dual-Band Internal Antenna (2.4/5 GHz).....	189
AP7612 Dual-Band Internal Antenna (2.4/5 GHz).....	191
AP-7632i Dual-Band Internal Antenna (2.4/5 GHz).....	194
AP7662i Dual-Band Internal Antenna (2.4/4.9/5 GHz).....	197
AP7622 Dual-Band Internal Antenna (2.4/5 GHz).....	199
ML-2452-PTA4M4-036, 4-Port, Dual-Band, Ceiling Mount, Circular Omni Array (4 V-Pol ports).....	201
ML-2452-SEC6M4-036, Dual Polarized, Dual Band Wide Beam Directional Antenna, 32 Inch Cable, RPSMA-Male Connector.....	207
ML-2452-HPA6M4-S36, Dual Band, Four Input Omni, 36 Inch Cable, RPSMA Connectors.....	209
ML-2452-PNL6M4-N36 Dual Polarized, Dual Band Narrow Beam Directional Antenna, with 36 Inch Cable and N-Male Connector.....	211
ML-2452-SEC6M4-N30 Dual Band Sector Antenna, with 30 Inch Cable and N Male Connectors.....	213
ML-2452-SEC6M4-N36 Dual Polarized Dual Band Wide Beam Directional Antenna, with 32 Inch Cable and N-Male Connector.....	215
Chapter 6: Antenna Cables.....	217
ML-1499-10JK-01R 10 ft. Low-Loss Coaxial Cable Jumper: N Male to N Male.....	217
ML-1499-25JK-01R 25 ft. Low-Loss Coaxial Cable Jumper: N Male to N Male with 2 Connector Seal Kits.....	217
Chapter 7: Supported Antenna Adapters.....	219
25-85391-01R 3.5 in. Jumper Cable, RP-SMA (Male) to Type N (Male) Adapter.....	219
25-85392-01R 3.5 in. Jumper Cable, RP-SMA (Male) to Type N (Female) Adapter.....	219
25-72178-01 Jumper, RP-SMA(M) to RP-BNC(F).....	220
25-90262-01R RP-SMA (Female) to Type N (Female) Adapter.....	220
25-90263-01R Type N (Male) to RP-SMA (Female) Bulkhead Adapter.....	221
25-99175-01R Type N, Female to Female Adapter.....	221
Chapter 8: Supported Lightning Arrestors.....	222
ML-1499-LAK1-01R 1 ft. N Male to RP BNC Male Lightning Arrestor with Connector Seal Kit...222	222
ML-2452-LAK1-01R Lightning Arrestor (N Female to N Female) with N Male to RP-SMA Male Adapter.....	223
ML-2452-LAK1-02R Type N, Male-Female.....	224
Chapter 9: Mounting Kits.....	225
ML-1499-SD3MK-01R Articulating I-Beam Mount Kit for ML-2499-SD3-01 Omni Antenna.....	225

Chapter 10: AP7131 Regulatory Domains.....	226
AP7131 Supported Antennas by Band, Model, Rate and Transmit Power.....	226
AP7131 Japan Regulatory Domain 2.4 GHz Band.....	237
AP7131 Japan Regulatory Domain 5.2 GHz Band.....	241
Chapter 11: AP650 Regulatory Domains.....	247
AP650 US Regulatory Domain 2.4 GHz Band.....	247
AP650 US Regulatory Domain 5 GHz Band.....	250
AP650 Japan Regulatory Domain 2.4 GHz Band.....	257
AP650 Japan Regulatory Domain 5 GHz Band.....	261
AP650 EU Regulatory Domain 2.4 GHz Band.....	269
AP650 EU Regulatory Domain 5 GHz Band.....	272
Chapter 12: RFS4011 Regulatory Domains.....	280
RFS4011 US Regulatory Domain 2.4 GHz Band.....	280
RFS4011 US Regulatory Domain 5 GHz Band.....	283
RFS4011 Canada Regulatory Domain 2.4 GHz Band.....	288
RFS4011 Canada Regulatory Domain 5 GHz Band.....	291
RFS4011 EU Regulatory Domain 2.4 GHz Band.....	297
RFS4011 EU Regulatory Domain 5 GHz Band.....	300
RFS4011 Japan Regulatory Domain 2.4 GHz Band.....	306
RFS4011 Japan Regulatory Domain 5 GHz Band.....	309
Chapter 13: AP-6511 Regulatory Domains.....	316
AP-6511 US Regulatory Domain 2.4 GHz Band.....	316
AP-6511 US Regulatory Domain 5 GHz Band.....	317
AP-6511 EU Regulatory Domain 2.4 GHz Band.....	318
AP-6511 EU Regulatory Domain 5 GHz Band.....	318
AP-6511 Japan Regulatory Domain 2.4 GHz Band.....	320
AP-6511 Japan Regulatory Domain 5 GHz Band.....	320
Chapter 14: AP-621 and AP-6521 Regulatory Domains.....	322
AP-621 (Standard Power) US Regulatory Domain 2.4GHz Band.....	322
AP-621 (Standard Power) US Regulatory Domain 5GHz Band.....	325
AP-6521 (High Power) US Regulatory Domain 2.4GHz Band.....	330
AP-6521 (High Power) US Regulatory Domain 5GHz Band.....	332
AP-621 (Standard Power) EU Regulatory Domain 2.4GHz Band.....	338
AP-621 (Standard Power) EU Regulatory Domain 5GHz Band.....	340
AP-6521 (High Power) EU Regulatory Domain 2.4GHz Band.....	346
AP-6521 (High Power) EU Regulatory Domain 5GHz Band.....	348
AP-621 (Standard Power) Japan Regulatory Domain 2.4GHz Band.....	354
AP-621 (Standard Power) Japan Regulatory Domain 5GHz Band.....	357
AP-6521 (High Power) Japan Regulatory Domain 2.4GHz Band.....	362
AP-6521 (High Power) Japan Regulatory Domain 5GHz Band.....	365
Chapter 15: AP622, AP6522 and AP6562 Regulatory Domains.....	371
AP622, AP6522, AP6562 US Regulatory Domain 2.4 GHz Band.....	371
AP622, AP6522, AP6562 US Regulatory Domain 5 GHz Band.....	374
AP622, AP6522, AP6562 EU Regulatory Domain 2.4 GHz Band.....	380
AP622, AP6522, AP6562 EU Regulatory Domain 5 GHz Band.....	383
AP622, AP6522, AP6562 Japan Regulatory Domain 2.4 GHz Band.....	390
AP622, AP6522, AP6562 Japan Regulatory Domain 5 GHz Band.....	393

Chapter 16: AP7161 Regulatory Domains.....	400
AP7161 US Regulatory Domain 2.4 GHz Band.....	400
AP7161 US Regulatory Domain 4.9 GHz Band.....	400
AP7161 US Regulatory Domain 5 GHz Band.....	401
AP7161 EU Regulatory Domain 2.4 GHz Band.....	402
AP7161 EU Regulatory Domain 5 GHz Band.....	403
AP7161 Japan Regulatory Domain 2.4 GHz Band.....	404
AP7161 Japan Regulatory Domain 5 GHz Band.....	405
Chapter 17: AP8132 Regulatory Domains.....	407
AP8132 US Regulatory Domain 2.4 GHz Band.....	407
AP8132 US Regulatory Domain 5 GHz Band.....	410
AP8132 EU Regulatory Domain 2.4 GHz Band.....	416
AP8132 EU Regulatory Domain 5 GHz Band.....	419
AP8132 Japan Regulatory Domain 2.4 GHz Band.....	425
AP8132 Japan Regulatory Domain 5 GHz Band.....	428
Chapter 18: AP8122 Regulatory Domains.....	436
AP8122 US Regulatory Domain 2.4 GHz Band.....	436
AP8122 US Regulatory Domain 5 GHz Band.....	436
AP8122 EU Regulatory Domain 2.4 GHz Band.....	438
AP8122 EU Regulatory Domain 5 GHz Band.....	438
Chapter 19: AP8163 Regulatory Domains.....	441
AP8163 US Regulatory Domain 2.4 GHz Band.....	441
AP8163 US Regulatory Domain 5 GHz Band.....	443
AP8163 EU Regulatory Domain 2.4 GHz Band.....	448
AP8163 EU Regulatory Domain 5 GHz Band.....	451
Chapter 20: AP8232 Regulatory Domains.....	457
AP8232 US Regulatory Domain 2.4 GHz Band.....	457
AP8232 US Regulatory Domain 5 GHz Band.....	460
AP8232 EU Regulatory Domain 2.4 GHz Band.....	468
AP8232 EU Regulatory Domain 5 GHz Band.....	471
AP8232 Japan Regulatory Domain 2.4 GHz Band.....	479
AP8232 Japan Regulatory Domain 5 GHz Band.....	482
Chapter 21: AP8222 Regulatory Domains.....	492
AP8222 US Regulatory Domain 2.4 GHz Band.....	492
AP8222 US Regulatory Domain 5 GHz Band.....	492
AP8222 EU Regulatory Domain 2.4 GHz Band.....	494
AP8222 EU Regulatory Domain 5 GHz Band.....	495
AP8222 Japan Regulatory Domain 2.4 GHz Band.....	497
AP8222 Japan Regulatory Domain 5 GHz Band.....	497
Chapter 22: AP7532 Regulatory Domains.....	500
AP7532 US Regulatory Domain 2.4 GHz Band.....	500
AP7532 US Regulatory Domain 5 GHz Band.....	503
AP7532 EU Regulatory Domain 2.4 GHz Band.....	511
AP7532 EU Regulatory Domain 5 GHz Band.....	513
AP7532 Japan Regulatory Domain 2.4 GHz Band.....	520
AP7532 Japan Regulatory Domain 5 GHz Band.....	522

AP7532 NCC Domain.....	526
Chapter 23: AP7522 Regulatory Domains.....	528
AP7522 US Regulatory Domain 2.4 GHz Band.....	528
AP7522 US Regulatory Domain 5 GHz Band.....	531
AP7522 EU Regulatory Domain 2.4 GHz Band.....	539
AP7522 EU Regulatory Domain 5 GHz Band.....	542
AP7522 Japan Regulatory Domain 2.4 GHz Band.....	548
AP7522 Japan Regulatory Domain 5 GHz Band.....	550
AP7522 NCC Domain.....	554
Chapter 24: AP7502 Regulatory Domains.....	556
AP7502 US Regulatory Domain 2.4 GHz Band.....	556
AP7502 US Regulatory Domain 5 GHz Band.....	556
AP 7502 EU Regulatory Domain 2.4 GHz Band.....	558
AP7502 EU Regulatory Domain 5 GHz Band.....	559
AP 7502 Japan Regulatory Domain 2.4 GHz Band.....	560
AP7502 Japan Regulatory Domain 5 GHz Band.....	561
AP7502 NCC Regulatory Domain 2.4 GHz Band.....	563
AP7502 NCC Regulatory Domain 5 GHz Band.....	563
Chapter 25: AP7562 Regulatory Domains.....	566
AP7562 US Regulatory Domain 2.4 GHz Band.....	566
AP7562 US Regulatory Domain 5 GHz Band.....	568
AP7562 EU Regulatory Domain 2.4 GHz Band.....	575
AP7562 EU Regulatory Domain 5 GHz Band.....	576
AP7562 Japan Regulatory Domain 2.4 GHz Band.....	580
AP7562 Japan Regulatory Domain 5 GHz Band.....	582
AP7562 NCC Domain.....	586
Chapter 26: AP8432 Regulatory Domains.....	588
AP8432 US Regulatory Domain 2.4 GHz Band.....	588
AP8432 US Regulatory Domain 5 GHz Band.....	588
AP8432 EU Regulatory Domain 2.4 GHz Band.....	590
AP8432 EU Regulatory Domain 5 GHz Band.....	591
Chapter 27: AP8533 Regulatory Domains.....	593
AP8533 US Regulatory Domain 2.4 GHz Band.....	593
AP8533 US Regulatory Domain 5 GHz Band.....	595
EU Regulatory Domain 2.4 GHz Band.....	602
AP8533 EU Regulatory Domain 5 GHz Band.....	605
Index.....	615
Glossary.....	611

Preface

Text Conventions

The following tables list text conventions that are used throughout this guide.

Table 1: Notice Icons





Icon	Notice Type	Alerts you to...
	General Notice	Helpful tips and notices for using the product.
	Note	Important features or instructions.
	Caution	Risk of personal injury, system damage, or loss of data.
	Warning	Risk of severe personal injury.
	New	This command or section is new for this release.

Table 2: Text Conventions

Convention	Description
Screen displays	This typeface indicates command syntax, or represents information as it appears on the screen.
The words enter and type	When you see the word “enter” in this guide, you must type something, and then press the Return or Enter key. Do not press the Return or Enter key when an instruction simply says “type.”
[Key] names	Key names are written with brackets, such as [Return] or [Esc] . If you must press two or more keys simultaneously, the key names are linked with a plus sign (+). Example: Press [Ctrl]+[Alt]+[Del]
<i>Words in italicized type</i>	Italics emphasize a point or denote new terms at the place where they are defined in the text. Italics are also used when referring to publication titles.

Platform-Dependent Conventions

Unless otherwise noted, all information applies to all platforms supported by ExtremeXOS® software, which are the following:

- ExtremeSwitching® switches
- Summit® switches
- SummitStack™

When a feature or feature implementation applies to specific platforms, the specific platform is noted in the heading for the section describing that implementation in the ExtremeXOS command documentation (see the Extreme Documentation page at <http://documentation.extremenetworks.com>). In many cases, although the command is available on all platforms, each platform uses specific keywords. These keywords specific to each platform are shown in the Syntax Description and discussed in the Usage Guidelines sections.

Providing Feedback to Us

We are always striving to improve our documentation and help you work better, so we want to hear from you! We welcome all feedback but especially want to know about:

- Content errors or confusing or conflicting information.
- Ideas for improvements to our documentation so you can find the information you need faster.
- Broken links or usability issues.

If you would like to provide feedback to the Extreme Networks Information Development team about this document, please contact us using our short [online feedback form](#). You can also email us directly at internalinfodev@extremenetworks.com.

Getting Help

If you require assistance, contact Extreme Networks using one of the following methods:

- **GTAC (Global Technical Assistance Center) for Immediate Support**
 - **Phone:** 1-800-998-2408 (toll-free in U.S. and Canada) or +1 408-579-2826. For the support phone number in your country, visit: www.extremenetworks.com/support/contact
 - **Email:** support@extremenetworks.com. To expedite your message, enter the product name or model number in the subject line.
- **GTAC Knowledge** — Get on-demand and tested resolutions from the GTAC Knowledgebase, or create a help case if you need more guidance.
- **The Hub** — A forum for Extreme customers to connect with one another, get questions answered, share ideas and feedback, and get problems solved. This community is monitored by Extreme Networks employees, but is not intended to replace specific guidance from GTAC.
- **Support Portal** — Manage cases, downloads, service contracts, product licensing, and training and certifications.

Before contacting Extreme Networks for technical support, have the following information ready:

- Your Extreme Networks service contract number and/or serial numbers for all involved Extreme Networks products
- A description of the failure
- A description of any action(s) already taken to resolve the problem
- A description of your network environment (such as layout, cable type, other relevant environmental information)
- Network load at the time of trouble (if known)
- The device history (for example, if you have returned the device before, or if this is a recurring problem)
- Any related RMA (Return Material Authorization) numbers

Extreme Networks Documentation

To find Extreme Networks product guides, visit our documentation pages at:

Current Product Documentation	www.extremenetworks.com/documentation/
Archived Documentation (for earlier versions and legacy products)	www.extremenetworks.com/support/documentation-archives/
Release Notes	www.extremenetworks.com/support/release-notes

Open Source Declarations

Some software files have been licensed under certain open source licenses. More information is available at: www.extremenetworks.com/support/policies/software-licensing.

1 Antenna Selection and Description

Antenna Selection

Antenna Selection Criteria

Antenna Accessories for Enterprise WLANs

Antenna Selection

While several antennas may work in a given environment, some will provide better coverage than others. Using the right antenna in the right location will maximize both the performance and coverage of your network. Understanding the key characteristics that describe how an antenna sends and receives radio frequency signals is critical to finding the ideal antenna for your deployment.

Enterprise Wireless LAN products operate in the 2.4 GHz and 5 GHz ISM bands allocated for unlicensed use. Access point and access port products available today support either the 802.11b/g/n or the 802.11a/n standard, or both. Wireless devices conforming to the 802.11b/g standard operate in the 2.4 GHz ISM band, while 802.11a devices operate in the 5 GHz band. The antennas in this guide are grouped according to the frequency band they support. Some antennas are designed to operate within either band. These antennas (described as “dual-band”) may be connected to radios operating in either the 2.4 or 5 GHz bands, although a single antenna may not be connected to two radios at the same time.

Connector Types and Definitions

There are combinations of antenna types and cables required to provide a satisfactory connection to the AP. One confusing factor is “reverse polarity”. Reverse polarity is the FCC’s requirement for each WLAN manufacturer to have unique access point connectors.

- 2.4 GHz is Reverse polarity BNC female (RP-BNC-F)
- 5 GHz is reverse polarity SMA female (RP-SMA-F)

Note



Reverse polarity presents confusion because of a lack of a standardized definition from connector manufactures. Reverse polarity provides a center element, which should not be confused with a male connector. A male connector is defined by the outer jacket of the connector rather than the center element.

The following are the connectors used within this guide:



Figure 1: RP-BNC-F



Figure 2: RP-BNC-M



Figure 3: RP-SMA-F



Figure 4: RP-SMA-M

Additionally, antennas deployed outdoors and industry standard accessories (like lightning arrestors) use Type-N connectors (as displayed below). Therefore, with the combinations devices required (access points/ports, antennas, cable extensions, and lightning arrestors), various adapter cables are required to connect an antenna to an access point/port.



Figure 5: Type N-F



Figure 6: Type N-M

Indoor and Outdoor Antennas

One important aspect of an antenna is whether it is weather sealed to protect it from the environment. Because of this extra protection, outdoor antennas are typically more expensive than those rated for indoor use. Outdoor antennas can be used for indoor applications, such as freezers and cooler where moisture is common. Outdoor antennas can be used for indoor applications, but indoor applications should not be used in outdoor applications.

One common distinction of outdoor antennas is the connector. Since lightning protection is always advised for outdoor antennas, these antennas typically have Type N Male to directly attach the lightning arrestor. This is true of 2.4 GHz, 5 GHz, and dual-band outdoor antennas.

Spectrum and Part Number Designations

The antennas listed in this document are ultimately referenced by part number. A numerical sequence is used within each antenna's part number to identify the spectrum supported by the antennas.

- The antenna part numbers with a 2499 indicates a 2.4 GHz antenna. For more information on the 2.4 GHz antenna suite, see [2.4 GHz Single Band Antenna Suite](#) on page 35.
- The antenna part numbers with a 5299 indicates a 5 GHz antenna. For more information on the 2.4 GHz antenna suite, see [5.2 GHz Single Band Antenna Suite](#) on page 46.
- The antenna part numbers with a 2452 indicates a dual band antenna (2.4GHz and 5 GHz). For more information on the 2.4 GHz antenna suite, see [2.4 GHz - 5.2 GHz Dual Band Antenna Suite](#) on page 56.

Extended AP to Antenna Cable Lengths

Most indoor antennas are intended to be mounted directly to the AP's connectors. Some mounting arrangements call for positioning the AP a significant distance away from the antenna due to serviceability or other reason. In these situations, various adapters and cable extensions are required.

In these situations be mindful of:

- The connector on the AP
- The connector on the antenna
- The spectrum being implemented
- Signal loss due to multiple connectors and long cable lengths

Combinations of these attributes present different parts required to complete the connection. The Product Compatibility matrix addresses the parts required to make a proper connection. For more information, see .

Antenna Selection Criteria

In addition to antenna frequency, there is other criteria to consider when selecting an antenna.

Antenna Pattern

Omnidirectional

Signal radiates from the antenna in all directions on the horizontal plane.

Directional

Signal radiates in a specific direction, typically described as a beam of given width, expressed in degrees in the horizontal and vertical plane. For more information, see and .

Antenna Type

Panel

A panel antenna is a flat antenna mounted to a wall or other vertical surface and radiates RF energy (radio waves) directionally away from the wall. They usually have gain greater than 5 dBi and are not suitable for omni-directional situations. Ideally suited for long hallways.

Patch

A patch antenna is a flat antenna mounted on the ceiling but whose pattern is omni-directional. Most of the energy goes out horizontally to the sides of the antenna and equal in all directions.

Dipole

A dipole antenna is a tubular antenna that can be either a pipe shape, a straight flexible rod or a paddle. This antenna has an omni-directional pattern when placed in a vertical position. It usually has 2 dBi of gain.

Dipole Array

Essentially a dipole, a dipole array is two or more dipoles that are placed one on top of the other, requiring a longer tube to hold them. The advantage of a dipole array is that it has higher gain.

Parabolic Grid

A parabolic grid antenna is a very directional, dish-like antenna. Its parabolic reflector focuses the RF energy like a flashlight. Most of the time the radiating element is a dipole, but when combined with the dish, it becomes very directional with gain up to 24 dBi. Usually used in long point-to-point systems.

Yagi

A yagi antenna is a antenna that has an internal structure resembling that of typical antennas used for TV reception (a series of rods perpendicular to a main rod, making a triangular shape). This is a directional antenna with less gain than the PGA, typically around 13 dBi. It may be used in either point-to-point situations, or to cover a very long, narrow area in point-to-multi-point situations.

Polarized Panel

A polarized panel antenna is a multi-port panel antenna with different linear polarization alignments on the different ports. Common polarization alignment orientations are Vertical/Horizontal and Vertical/45°-Slant. Polarized panel antennas are useful on outdoor Line-of-Sight links, and are also used in indoor deployments for improved coverage uniformity at the expense of slightly reduced range.

Antenna Performance Characteristics

Frequency

The frequency band within which the antenna performs at the stated specifications

Gain (dBi)

The relative amplification of the antenna with respect to an equivalent isotropic antenna, expressed on the decibel logarithmic scale.

Cable loss (dB)

The signal strength loss introduced by the cable connected to the antenna expressed on the decibel logarithmic scale.

Net gain (dBi)

The resulting amplification of the antenna paired with its cable.

Polarization

The orientation of the electrical field which the antenna is optimized to receive. If the transmitting and receiving antennas are both linear polarized, then turning one 90° so that they are cross polarized will reduce the range significantly.

VSWR

Voltage Standing Wave Ratio (VSWR) is the ratio of maximum voltage to minimum voltage along the line. Expresses the degree of match between the transmission line and the terminating element (antenna). When VSWR is 1:1 the match is perfect, a VSWR of 1.5:1 corresponds to 96% power efficiency.

Azimuth 3dB Beamwidth

Width of the antenna beam on the horizontal plane expressed in degrees.

Elevation 3dB Beamwidth

Height of the antenna beam on the vertical plane expressed in degrees.

Antenna Accessories for Enterprise WLANs

A complete selection of antennas and accessories is available to ensure optimal coverage and performance for wireless LANs. Regardless of the size or layout of your environment, from a small office or storefront to campus-wide, multiple-site, indoor and outdoor deployments, antennas, cables and accessories are available to fit your needs.

By combining this portfolio with a broad line of wireless switches, access ports, access points, client connectivity cards, ruggedized mobile voice/data devices and network management software, as well as wireless mobility planning and deployment services. For more information visit <https://portal.motorolasolutions.com/Support/US-EN/Wireless+Networks>.

Choosing the Right Antenna and accessories for your WLAN

It is important to consider a number of factors when choosing an antenna and accessories for your Enterprise WLAN. To choose the right components, you'll need to know:

- Where is the antenna to be installed, and what type of coverage is required. Knowing the intended radio band is central. Determine if the intended radio coverage area supports dual 2.4/5.2 band traffic. Has the attenuation of the coverage been discerned in respect to known barriers.
- The band (802.11b/g/n or 802.11a/n) your network supports
- Which AP to use
- Whether you will be deploying the network indoors or outdoors
- The distance between AP and antenna, to determine extender cable length, if any
- The serviceability requirement for each AP and antenna deployment

Review the chart to determine which antennas suit your needs. Using the part numbers provided, determine which of the antennas will work with your hardware in your environment.



2 Product Compatibility

FCC Compliance
FCC Approval Statement
FCC USA Compatibility Matrix

To find the right antenna and accessories for your deployment:

- Find your access point or access port model at the top of the chart (refer to the chart on the following page). Follow that column down to find the antennas, cables and lightning arrestors compatible with that model access port or access point. Write those part numbers down.
- Follow the row antenna across the table to the columns for the lightning arrestors and cables you wrote down to confirm that they compatible with the antenna you've chosen and determine if an adapter is required to connect the two selected parts.

FCC Compliance

Enterprise Access Points are approved by the FCC with the understanding that these devices are Professionally Installed. Under FCC regulations, this allows the Professional Installers the flexibility to configure the Access Points for each specific customers needs and insure a compliant installation. The antennas offered in our portfolio have different coverage patterns and antenna gains to meet the needs of different installation requirements and require careful planning. The Access Point transmitter power must be adjusted by the professional installer based on the specific antenna and other installation components used in the installation to ensure compliant operation.

A professional installer must:

- Have a good understanding of RF theory
- Be able to calculate a link budget for a given transmitter configuration. For example, Conducted Output Power + Cabling Losses + Mechanical Connection Losses + Antenna Gain = Output Power (This output power should be equal or lower than the Maximum Power as listed on the FCC Grant for a transmitter)
- Be familiar with both the mechanical and software tools required to configure and adjust the transmitter being installed
- Understand basic FCC regulations for the site specific location and installation requirements of the various radio products being installed
- Understand basic antenna operational theory and standard industry antenna installation practices
- Be certified by local authorities to install electrical devices.



Warning

OPERATING A TRANSMITTER THAT IS CONFIGURED FOR INDOOR USE IN AN OUTDOOR ENVIRONMENT IS AGAINST FCC REGULATIONS AND SUBJECT TO FCC ENFORCEMENT ACTIONS AGAINST BOTH THE INSTALLER AND THE OPERATOR.

Outdoor Access Point Installations

The FCC regulations for the indoor and outdoor installation are different; the professional installer must configure the Access Point transmitters accordingly. Products that are specifically intended to be placed outdoors are configured at the factory for compliant outdoor operation. Professional installers should review the following to assess the legality of outdoor deployments:

- If a transmitter is placed indoors but the antenna is placed outdoors, the FCC interprets this as an outdoor installation
- If a transmitter is placed indoors and the antenna is oriented to intentionally radiate outdoors, the FCC interprets this as an outdoor installation
- If the transmitter is placed on a loading dock or inside a covered stadium with a retractable cover, the FCC views this as an outdoor installation

The Federal Communications Commission (FCC), the National Telecommunications and Information Administration (NTIA) and the Federal Aviation Administration (FAA) have an ongoing investigation of interference caused to Terminal Doppler Weather Radar (TDWR) systems operating in the 5600-5650 MHz band. TDWRs are used to detect wind shear and other weather conditions near airports.

The interference at most locations was attributed to fixed wireless transmitters operating outdoors in the vicinity of airports at high elevations that are line-of-sight to the TDWR installations (5 GHz network equipment).

In some instances, the interference was caused by equipment that was not properly certified or configured. In other instances, equipment was FCC certified nonetheless caused interference. The FCC has taken appropriate enforcement action in each of these cases.

If everything is determined to be compliant - the FCC orders the interfering transmitter turned off or adjustments be made such that there is no more interference; any non-compliance determined is resolved with an enforcement action.

On 14 OCTOBER2010 the FCC published the following notice that requests that devices operating in the 5.4 GHz band located near the appended list of airports register these devices. A voluntary WISPA sponsored database has been developed that allows operators and installers to register the location information of the UNII devices operating outdoors in the 5470 - 5725 MHz band within 35 am of any TDWR location.



Note

The voluntary registration of all outdoor installations is strongly encouraged at <http://www.spectrumbridge.com/udia/home.aspx>.

FCC Approval Statement

Federal Communications Commission Office of Engineering and Technology Laboratory Division

Interim Plans to Approve UNII Devices Operating in the 5470 - 5725 MHz Band with Radar Detection and DFS Capabilities

The FCC, NTIA, FAA and industry are working to resolve interference to Terminal Doppler Weather Radar (TDWR) systems used near airports that has occurred from some outdoor wireless systems operating in the 5470 MHz - 5725 MHz band. These wireless devices are subject to Section 15.407 of our

rules and when operating as a master device they are required to implement radar detection and DFS functions. We are continuing our work to develop long-term equipment authorization test procedures that will ensure that the devices comply with our rules that include protecting the TDWR operations. In the interim, the Commission will now allow certification of wireless master devices with radar detection function and with DFS capability, if they meet the following conditions:

- Devices will not transmit on channels which overlap the 5600 – 5650 MHz band.¹
 - Devices intended for outdoor use will be further restricted, as follows:
 - Devices must be professionally installed when operating in the 5470 – 5725 MHz band.²
 - Grantees must provide owners, operators and all such installers with specific instructions in their user's manual on requirements to avoid interference to TDWRs and information that meets the following instructions:
 - Any installation of either a master or a client device within 35 km of a TDWR location shall be separated by at least 30 MHz (center-to-center) from the TDWR operating frequency (as shown in the attached table) 3, 4, and 5.
- 1 The devices subject to the requirements in this KDB can select the initial channel for operation to avoid TDWRs and apply the Uniform Channel Spreading requirements (see FCC 06-96 in ET Docket 03-122 released June 30, 2006) on the remaining available frequency band of operation. All the other test procedures including the test radar patterns remain the same at the present time. A revision to the measurement procedure with modification to the Uniform Channel Spreading requirement and other changes will be released in the future. The Commission will also address the issue of any field upgrade option at that time.
 - 2 The grantee must identify the specific expertise and the training required by the installers for installing these types of devices.
 - 3 In some instances it is possible that a device may be within 35 km of multiple TDWRs. In this case the device must ensure that it avoids operation within 30 MHz for each of the TDWRs. This requirement applies even if the master is outside the 35 km radius but communicates with outdoor clients which may be within the 35 km radius of the TDWRs.
 - 4 The requirement for ensuring 30 MHz frequency separation is based on the best information available to date. If interference is not eliminated, a distance limitation based on line-of-sight from TDWR will need to be used. In addition, devices with bandwidths greater than 20 MHz may require greater frequency separation.
- Procedures for the installers and the operators on how to register the devices in the industry-sponsored database with the appropriate information regarding the location and operation of the device and installer information is included.⁶
 - Devices must meet all of the other requirements specified in Section 15.407, and it is prohibited to include configuration controls (e.g. country code settings or other options to modify DFS functions) to change the frequency of operations to any frequency other than those specified on the grant of certification for US operation.⁷
 - All applications for equipment authorization must clearly show compliance with all of the technical requirements under worst case parameters, under user or operator control, based on frame rates, listen/talk ratios and user data transfer conditions.

All the devices subject to the DFS requirements must be submitted to the Commission's Laboratory Division for pre-grant testing and equipment authorization.⁸ The applicant must ensure that all equipment authorization applications subject to this interim procedure include appropriate attestations that the device has no option to change the DFS parameters and that transmissions are

disabled at least in the 5600 – 5650 MHz band. The application must include the user’s manual with the appropriate installation and operations requirements for the installers and operators.

We are continuing to evaluate additional measures that may need to be taken to further ensure against interference caused by 5 GHz outdoor wireless systems located near airports. While manufacturers have an obligation to ensure that their equipment complies with FCC rules, and must take steps to ensure their devices are unlikely to cause harmful interference, Section 15.5 of the Commission’s rules also places an obligation on users of devices to avoid causing interference and to correct any interference that may occur. We encourage the manufacturers to include information for the users, including the operators and installers, to ensure that they understand that it is incumbent on them to cooperate with manufacturers to implement any changes necessary to facilitate compliance.

5 Devices may be optionally designed not to transmit on channels which overlap 5570 – 5680 MHz instead of requiring installers to perform site-by-site adjustments. In that case it is still required that the devices should be installed professionally and the procedures for registering the device in the industry database should be included in the Users Manual.

6 A voluntary WISPA sponsored database has been developed that allows operators and installers to register the location information of the UNII devices operating outdoors in the 5470 – 5725 MHz band within 35 km of any TDWR location (see <http://www.spectrumbridge.com/udia/home.aspx>). This database may be used by government agencies in order to expedite resolution of any interference to TDWRs.

7 For example, device software must not have any country code options or software configuration settings which allow an end user to modify the DFS operation or impact the performance of DFS. See KDB 594280.

8 The TCBs are not permitted to approve transmitters with radar detection capabilities. See KDB 628591.

9 The manufacturers may consider taking steps providing clear instructions to operators and installers of devices as to the need to comply with rules for use of the band, guidance on registration of devices and any other processes that are designed to avoid interference. They may use methods that include, but are not limited to, instructions in manuals, notification on product web pages and service bulletins issued for products in the field.

Table 1: TDWR Location Information*

STATE	CITY	LONGITUDE	LATITUDE	FREQUENCY	TERRAIN ELEVATION (MSL) [ft]	ANTENNA HEIGHT ABOVE TERRAIN [ft]
AZ	PHOENIX	W 112 09 46	N 33 25 14	5610 MHz	1024	64
CO	DENVER	W 104 31 35	N 39 43 39	5615 MHz	5643	64
FL	FT LAUDERDALE	W 08020 39	N 26 08 36	5645 MHz	7	113
FL	MIAMI	W 080 29 28	N 25 45 27	5605 MHz	10	113
FL	ORLANDO	W 081 19 33	N 2820 37	5640 MHz	72	97
FL	TAMPA	W 082 31 04	N 27 51 35	5620 MHz	14	80

STATE	CITY	LONGITUDE	LATITUDE	FREQUENCY	TERRAIN ELEVATION (MSL) [ft]	ANTENNA HEIGHT ABOVE TERRAIN [ft]
FL	WEST PALM BEACH	W 080 16 23	N 26 41 17	5615 MHz	20	113
GS	ATLANTA	W 084 15 44	N 33 38 48	5615 MHz	962	113
IL	MCCOOK	W 087 51 31	N 41 47 50	5615 MHz	646	97
IL	CRESTWOOD	W 087 43 47	N 41 39 05	5645 MHz	663	113
IN	INDIANAPOLIS	W 086 26 08	N 39 38 14	5605 MHz	751	97
KS	WICHITA	W 097 26 13	N 37 30 26	5603 MHz	1270	80
KY	COVINGTON CINNCINNATI	W 084 34 48	N 38 53 53	5610 MHz	942	97
KY	LOUISVILLE	W 085 36 38	N 38 02 45	5646 MHz	617	113
LA	NEW ORLEANS	W 090 24 11	N 30 01 18	5645 MHz	2	97
MA	BOSTON	W 070 56 01	N 42 09 30	5610 MHz	151	113
MD	BRANYWINE	W 076 50 42	N 38 41 43	5635 MHz	233	113
MD	BENFIELD	W 076 37 48	N 39 05 23	5645 MHz	184	113
MD	CLINTON	W 076 57 43	N 38 45 32	5615 MHz	249	97
MI	DETROIT	W 083 30 54	N 42 0640	5615 MHz	656	113
MN	MINNEAPOLIS	W 092 55 58	N 44 52 17	5610 MHz	1040	80
MO	KANSAS CITY	W 094 44 31	N 39 29 55	5605 MHz	1040	64
MO	SAINT LOUIS	W 090 29 21	N 38 4820	5610 MHz	551	97
MS	DESOTO COUNTY	W 089 59 33	N 34 53 45	5610 MHz	371	113
NC	CHARLOTTE	W 080 53 06	N 3520 14	5608 MHz	757	113
NC	RALEIGH DURHAM	W 078 41 50	N 36 00 07	5647 MHz	400	113
NJ	WOODBRIIDGE	W 074 16 13	N40 35 37	5620 MHz	19	113
NJ	PENNSAUKEN	W 075 04 12	N 39 56 57	5610 MHz	39	113
NV	LAS VEGAS	W 115 00 26	N 36 08 37	5645 MHz	1995	64
NY	FLOYD BENNETT FIELD	W 073 52 49	N40 3520	5647 MHz	8	97
OH	DAYTON	W 084 07 23	N40 0119	5640 MHz	922	97
OH	CLEVELAND	W 082 00 28	N 41 17 23	5645 MHz	817	113
OH	COLUMBUS	W 082 42 55	N40 0020	5605 MHz	1037	113
OK	AERO. CTR TDWR #1	W 097 37 31	N 35 24 19	5610 MHz	1285	80
OK	AERO. CTR TDWR #2	W 097 37 43	N 35 23 34	5620 MHz	1293	97
OK	TULSA	W 095 49 34	N 36 04 14	5605 MHz	712	113

STATE	CITY	LONGITUDE	LATITUDE	FREQUENCY	TERRAIN ELEVATION (MSL) [ft]	ANTENNA HEIGHT ABOVE TERRAIN [ft]
OK	OKLAHOMA CITY	W 097 30 36	N 35 16 34	5603 MHz	1195	64
PA	HANOVER	W 080 29 10	N40 30 05	5615 MHz	1266	113
PR	SAN JUAN	W 066 10 46	N 18 28 26	5610 MHz	59	113
TN	NASHVILLE	W 086 39 42	N 35 58 47	5605 MHz	722	97
TX	HOUSTON INTERCONTL	W 095 34 01	N 30 03 54	5605 MHz	154	97
TX	PEARLAND	W 095 14 30	N 29 30 59	5645 MHz	36	80
TX	DALLAS LOVE FIELD	W 096 58 06	N 32 55 33	5608 MHz	541	80
TX	LEWISVILLE DFW	W 096 55 05	N 33 03 53	5640 MHz	554	31
UT	SALT LAKE CITY	W 111 55 47	N40 58 02	5610 MHz	4219	80
VA	LEESBURG	W 077 31 46	N 39 05 02	5605 MHz	361	113
WI	MILWAUKEE	W 088 02 47	N 42 49 10	5603 MHz	820	113

FCC USA Compatibility Matrix

The following (on the next page) displays FCC approved AP radio, antenna, cable and accessory combinations for use in the United States for both current and legacy access points. The remaining pages in this section show matrices by product and region.

FCC USA Compatibility Matrix

		AP Radios								Cables				LAs						
		AP-7131 ABGN (U57AP7131)	AP-7131N ABGN (U27AP7131N)	AP-650/6532 (U27MIB82)	AP-621/6521 (U27/AP6)	AP-7161 (QIEAP716101)	AP-622/6522 (U27AP622)	AP-6562 (U27AP6522)	AP-8132 (U27KHAP800)	AP-8163 (U27KHAP800)	AP-8232 (U27RAAP800)	AP-7562 (H9PAP7562)	ML-1499-100JK-01R	ML-1499-10JK-01R	ML-1499-25JK-01R	ML-1499-50JK-01R	ML-1499-72PJ-01R	ML-1499-LAK1-01R	ML-1499-LAK2-01R	ML-2452-LAK1-01R
2.4 GHz	ML-2499-FHPA5-01R	7	7	7	X	7	7	7	7	7	7	A	A	A	A	X	5	5	5	
	ML-2499-HPA3-02R	X	X	*	*	5	5	5	5	X		4	4	4	4	X	5	5	5	
	ML-2499-HPA4-01	X	7	7	7	7	7	7	7	7		A	A	A	A	X	*	*	*	
	ML-2499-HPA8-01	X	X	7	X	7	7	7	7	7	X	A	A	A	A	X	*	*	*	
5 GHz	ML-2499-PNAHD-02R	*	*	*	X	X	5	5	5	X		4	4	4	4	X	5	5	5	
	ML-5299-FHPA6-01R	7	7	7	X	7	7	7	7	7	X	A	A	A	A	X	*	*	*	
	ML-5299-HPA1-01R	*	*	*	5	5	5	5	5	X		4	4	4	4	X	5	5	5	
	ML-5299-HPA5-01	X	7	7	7	7	7	7	7	7		A	A	A	A	X	*	*	*	
Dual-Band	ML-5299-HPA10-01	X	X	7	X	X	X	7	7	7	X	A	A	A	A	X	*	*	*	
	ML-2452-APA2-01	*	*	*	X	X	X	X	X	X	X	X	X	X	X	X	X	X	X	X
	ML-2452-APA2-02	*	*	*	X	X	X	X	X	X	X	X	X	X	X	X	X	X	X	X
	ML-2452-APAG2A1-01	X	X	X	X	X	X	X	X	X	X									
	ML-2452-APAG2A1-02	X	X	X	X	X	X	X	X	X	X									
	ML-2452-HPA5-036	*	*	*	5	5	5	5	5	X										
	ML-2452-HPA6-01	X	X	X	X	7	7	7	7	7										
	ML-2452-HPA6M6-072	X	X	X	X	5	X	X	5	5										
	ML-2452-HPA6X6-036	X	7	7	7	7	7	7	7	7		A	A	A	A	X	*	*	*	
	ML-2452-HPAG4A6-01	X	X	*	*	*	*	7	7	7		A	A	A	A	X	*	*	*	
	ML-2452-HPAG5A8-01	X	X	X	X	*	*	7	7	X		A	A	A	A	X	*	*	*	
	ML-2452-PNA5-01R	7	7	7	7	7	X	7	7	7		A	A	A	A	X	*	*	*	
	ML-2452-PNA7-01R	7	7	X	X	X	7	7	7	7	X	A	A	A	A	X	*	*	*	
	ML-2452-PNL9M3-036	*	*	X	X	X	5	5	5	5										
	ML-2452-PTA2M2-036	X	*	*	X	X	X	X	X	X	X		4	4	4	4	X	5	5	5
	ML-2452-PTA2M3X3-1	*	*	X	X	X	X	X	X	X	X									
	ML-2452-PTA3M3-036	X	*	*	X	X	X	X	X	X	X									
	ML-2452-PTA6M6-1	X	X	X	X	X	X	X	X	X	X									
	ML-2452-PTA6M6-036	X	X	X	X	X	X	X	X	X	X									
	ML-2452-PTA6X6-036	*	*	*	X	X	X	X	X	X	X		4	4	4	4	X	5	5	5
ML-2452-PNL3M3-1	X	X	X	X	X	X	X	X	X	X										
ML-2452-PNL6M3-N36	X	X	X	X	X	X	X	X	X	X										
ML-2452-PNL9M3-N36	7	7	X	X	X	X	7	7	7											
ML-2452-SEC6M3-N36	X	X	X	X	X	X	X	X	X	X										
ML-2452-VMM3M3-036	X	X	X	X	5	X	X	5	X	5		4	4	4	4	X	5	5	5	
ML-2452-VMM5M3-N72	X	X	X	X	X	X	X	X	X	X										

Key	Adapter P/N	Adapter Description
1	ML-1499-RBNCA1-01R	RP-BNC-F to N-F
2	ML-1499-RBNCA2-01R	RP-BNC-F to N-M
3	25-72178-01	RP-SMA-M to RP-BNC-F
4	25-90262-01R	RP-SMA-F to N-F
5	25-90263-01R	RP-SMA-F to N-M
6	25-85391-01R	RP-SMA-M to N-M
7	25-85392-01R	RP-SMA-M to N-F
8	must use ML-1499-LAK1-01R	
9	25-97261-01R	N-M to RP-BNC-M
A	25-99175-01R	N-F to N-F

Key	Description
*	Compatible
X	Not compatible
	Not required
	Outdoor rated

AP-8533 North America

Antenna Type	Antenna Part Number	Antenna connector (ports)	Antenna adapter (Note 1,3)	Max Gain (dBi)			Elevation Gain (dBi)	Azimuth beamwidth (approx)	Elevation beamwidth (approx)	Antenna connector (ports)	
				2.4GHz	4.9GHz	5GHz					
Dipole	ML-2499-FHPA5-01R	N male		5			n/a	360	25	US, Canada	
	ML-2499-HPA3-02R	RP SMA male		5			n/a	360	32		
	ML-2499-HPA8-01	N male		8			n/a	360	14		
	ML-5299-APA1-01R	RP SMA male				4	n/a	360	60		
	ML-5299-FHPA6-01R	N male			8.25	8.25	-6.05	360	16		
	ML-5299-HPA5-01	N male				5.6	-2.5	360	22		
	ML-5299-HPA10-01	N male			10.5		-10.5	360	8		
	ML-2452-APA2-01	RP SMA male	*	3.17		4.9	n/a	360	45	Y	
	ML-2452-APA2-02	RP SMA male	*	3.17		4.9	n/a	360	45	Y	
	ML-2452-APAG2A1-01	RP SMA male	*	2.7	2	2	n/a	360	60	Y	
	ML-2452-APAG2A1-02	RP SMA male	*	2.7	2	2	n/a	360	60	Y	
	ML-2452-HPA5-036	RP SMA male	*	3		5	-2.6	360	50	Y	
	ML-2452-HPA6-01	N male		7	5.3	4.6	6.1	4.09	360	30	Y
	ML-2452-HPA6M6-072	RP SMA male	*	2.8		6.5	-0.56	360	66	Y	
	ML-2452-HPA6X6-036	N male (6)		7	4	6	6	-3.9	360	45	Y
	ML-2452-HPAG4A6-01	N male		7	4		7.3	5.7	360	18	Y
	ML-2452-HPAG5A8-01	N male		7	7.5		8	-9.7	360	28	
	ML-2452-VMM3M3-036	RP SMA male (3)	*		4.5	5.4	5.4	1.3	360	40	Y
	ML-2452-VMM5M3-N72	N male (3)		7	4.5	5.4	5.4	2.9	360	40	Y
	ML-2452-HPA6M4-S36 (Note 1)	RP SMA male (4)	*		6	6	6	2	360	50	Y
ML-2452-PNA5-01R	N male		7	5.5	6	6	5.2	120	60	Y	
Panel	ML-2452-PNA7-01R	N male		8	12	12	7.5	68	66		
	ML-2452-PTA6M6-036	RP SMA male (6)	*	5	6	6	na	360	55	Y	
	ML-2452-PNL6M4-N36	RPSMA (4)	*	5.6	6.7	5.5	5.48	90	110	Y	
	ML-2452-SEC6M4-036 (Note 2)	RPSMA (4)	*	6.92	-	6.07	3.98	100	90	Y	
	ML-2452-SEC6M4-N30	N male (4)		7	5.5	-	6	2	60	60	Y
	ML-2452-SEC6M4-N36 (Note 2)	N male (4)		7	6.92	-	7.23	3.98	100	90	Y
Patch	ML-2452-PTA4M4-036	RP SMA male (4)	*	5.5	6	5	n/a	360	70	Y	
	ML-2452-PTA2M2-036	RP SMA male (2)	*	4	5	n/a	n/a	360	60	Y	
	ML-2452-PTA3M3-036	RP SMA male (3)	*	5	4	4	n/a	360	60	Y	
	ML-2452-PTA6X6-036	RP SMA male (6)	*	3		5	n/a	360	75	Y	
Polarized Panel	ML-2452-SEC6M4-036	RP SMA male (4)	*	6.92	7.23	3.95	-1.2	100	90	Y	
	ML-2452-PNL3M3-1	N male (4)		9.7	9.2	9.2	9.2	90	45		
	ML-2452-PNL6M3-N36	N male (3)	7	6	6	6	1.2	110	75	Y	
	ML-2452-PNL9M3-036	RP SMA male (3)		11	10.7	10.7	7.5	75	70		
	ML-2452-PNL9M3-N36	N male (3)		11	10.7	10.7	7.3	75	55		
ML-2452-SEC6M3-N36	N male (3)		7	6.5	5	5	3.4	90	80	Y	

N/A or No

Outdoor rated

Note 1: Requires external 1 dB attenuator for each antenna port (or 1ft cable)

Note 2: Requires external 2 dB attenuator for each antenna port (or 1ft cable)

Note 3:	AP to antenna adapter	Description	Adapter part number
	5	RP SMA to N-male	25-90263-01R
	7	RP SMA to N-female	25-85392-01R
	*	Compatible, no adapter needed	n/a

AP-8533 EMEA

Antenna Type	Antenna Part Number	Antenna connector (ports)	Antenna adapter (Note 1,3)	Max Gain (dBi)			Azimuth beamwidth (approx)	Elevation beamwidth (approx)	Countries
				2.4GHz	4.9GHz	5GHz			
Dipole	ML-2499-FHPA5-01R	N male		5			360	25	EU
	ML-2499-HPA3-02R	RP SMA male		5			360	32	
	ML-2499-HPA8-01	N male		8			360	14	
	ML-5299-APA1-01R	RP SMA male				4	360	60	
	ML-5299-FHPA6-01R	N male			8.25	8.25	360	16	
	ML-5299-HPA5-01	N male				5.6	360	22	
	ML-5299-HPA10-01	N male			10.5	10.5	360	8	
	ML-2452-APA2-01	RP SMA male	*	3.17		4.9	360	45	Y
	ML-2452-APA2-02	RP SMA male	*	3.17		4.9	360	45	Y
	ML-2452-APAG2A1-01	RP SMA male	*	2.7	2	2	360	60	Y
	ML-2452-APAG2A1-02	RP SMA male	*	2.7	2	2	360	60	Y
	ML-2452-HPA5-036	RP SMA male	*	3		5	360	50	Y
	ML-2452-HPA6-01	N male	7	5.3	4.6	6.1	360	30	Y
	ML-2452-HPA6M6-072	RP SMA male	*	2.8		6.5	360	66	Y
	ML-2452-HPA6X6-036	N male (6)	7	4	6	6	360	45	Y
	ML-2452-HPAG4A6-01	N male	7	4		7.3	360	18	Y
	ML-2452-HPAG5A9-01	N male	7	7.5		8	360	28	Y
	ML-2452-VMM3M3-036	RP SMA male (3)	*	4.5	5.4	5.4	360	40	Y
	ML-2452-VMM5M3-N72	N male (3)	7	4.5	5.4	5.4	360	40	Y
	ML-2452-HPA6M4-S36	RP SMA male (4)	*	6	6	6	360	50	
Panel	ML-2452-PNA5-01R	N male	7	5.5	6	6	120	60	Y
	ML-2452-PNA7-01R (Note 1)	N male		8	12	12	68	66	Y
	ML-2452-PTA6M6-036	RP SMA male (6)	*	5	6	6	360	55	Y
	ML-2452-PNL6M4-N36	RPSMA (4)	*	5.6	6.7	5.5	90	110	Y
	ML-2452-SEC6M4-036 (Note 2)	RPSMA (4)	*	6.92	-	6.07	100	90	
	ML-2452-SEC6M4-N30	N male (4)	7	5.5	-	6	60	60	Y
Patch	ML-2452-SEC6M4-N36 (Note 2)	N male (4)	7	6.92	-	7.23	100	90	
	ML-2452-PTA4M4-036	RP SMA male (4)	*	5.5	6	5	360	70	Y
	ML-2452-PTA2M2-036	RP SMA male (2)	*	4	5	n/a	360	60	Y
	ML-2452-PTA3M3-036	RP SMA male (3)	*	5	4	4	360	60	Y
Polarized Panel	ML-2452-PTA6X6-036	RP SMA male (6)	*	3		5	360	75	Y
	ML-2452-SEC6M4-036	RP SMA male (4)	*	6.92	7.23	3.95	100	90	Y
	ML-2452-PNL3M3-1	N male (4)		9.7	9.2	9.2	90	45	
	ML-2452-PNL6M3-N36	N male (3)	7	6	6	6	110	75	Y
	ML-2452-PNL9M3-036	RP SMA male (3)		11	10.7	10.7	55	55	
ML-2452-PNL9M3-N36	N male (3)		11		10.7	55	55		
ML-2452-SEC6M3-N36	N male (3)	7	6.5	5	5	90	80	Y	

 N/A or No
 Outdoor rated

Note 1: Requires external 2dB attenuator for each antenna port
 Note 2: Requires external 1dB attenuator for each antenna port
 Note 3:

AP to antenna adapter	Description	number
5	RP SMA to N-male	25-90263-01R
7	RP SMA to N-female	25-85392-01R
*	adapter needed	n/a

AP-7522 North America

Antenna Type	Antenna Part Number	Antenna connector (Number of ports)	AP to Antenna adaptor (Note 1,2)	Max Gain (dBi)			Elevation Gain (dBi)	Azimuth beamwidth (approx)	Elevation beamwidth (approx)	Country
				2.4GHz	4.9GHz	5GHz				
										US, Canada
Dipole	ML-2499-FHPA5-01R	N male		5			n/a	360	25	
	ML-2499-HPA3-02R	RP SMA male		5			n/a	360	32	
	ML-2499-HPA8-01	N male		8			n/a	360	14	
	ML-5299-APA1-01R	RP SMA male				4		360	60	
	ML-5299-FHPA6-01R	N male			8.25	8.25	-6.05	360	16	
	ML-5299-HPA5-01	N male				5.6	-2.5	360	22	
	ML-5299-HPA10-01	N male			10.5	10.5	-10.5	360	8	
	ML-2452-APA2-01	RP SMA male	*	3.17		4.9	n/a	360	45	Y
	ML-2452-APA2-02	RP SMA male	*	3.17		4.9	n/a	360	45	Y
	ML-2452-APAG2A1-01	RP SMA male	*	2.7	2	2	n/a	360	60	Y
	ML-2452-APAG2A1-02	RP SMA male	*	2.7	2	2	n/a	360	60	Y
	ML-2452-HPA5-036	RP SMA male	*	3		5	-2.6	360	50	Y
	ML-2452-HPA6-01	N male	7	5.3	4.6	6.1	4.09	360	30	Y
	ML-2452-HPA6M6-072	RP SMA male	7	2.8		6.5	-0.56	360	66	Y
	ML-2452-HPA6X6-036	N male (6)	7	4	6	6	-3.9	360	45	Y
	ML-2452-HPA6X6-01	N male	7	4		7.3	5.7	360	18	Y
	ML-2452-HPA6X6-01	N male	7	7.5		8	-9.7	360	28	Y
	ML-2452-VMM3M3-036	RP SMA male (3)	7	4.5	5.4	5.4	TBD	360	40	Y
	ML-2452-VMM5M3-N72	N male (3)	7	4.5	5.4	5.4	2.9	360	40	Y
	Panel	ML-2452-PNA5-01R	N male	7	5.5	6	6	5.2	120	60
ML-2452-PNA7-01R		N male		8	12	12	TBD	68	66	
ML-2452-PTA6M6-036		RP SMA male (6)	*	5	6	6	na	360	55	Y
Patch	ML-2452-PTA4M4-036	RP SMA male (4)		5.5	6	5	n/a	360	70	
	ML-2452-PTA2M2-036	RP SMA male (2)	*	4	5	n/a	n/a	360	60	Y
	ML-2452-PTA3M3-036	RP SMA male (3)		5	4	4	n/a	360	60	
	ML-2452-PTA6X6-036	RP SMA male (6)		3		5	n/a	360	75	
Polarized Panel	ML-2452-SEC6M4-036	RP SMA male (4)	*	6.92	7.23	3.95	TBD	100	90	Y
	ML-2452-PNL3M3-1	N male (3)	7	9.7	9.2	9.2	TBD	90	45	Y
	ML-2452-PNL6M3-N36	N male (3)	7	6	6	6	12	110	75	Y
	ML-2452-PNL9M3-036	RP SMA male (3)	5	11	10.7	10.7	7.5	55	55	Y
	ML-2452-PNL9M3-N36	N male (3)	7	11	10.7	10.7	7.3	55	55	Y
ML-2452-SEC6M3-N36	N male (3)	7	6.5	5	5	3.4	90	80	Y	
Note 1:										
	N/A or No									
	Outdoor rated antenna									
Note 2:										
AP to antenna adaptor	Description	Adaptor part number								
5	RP SMA to N-male	25-90263-01R								
7	RP SMA to N-female	25-85392-01R								
*	Compatible, no adaptor needed	n/a								

AP-7522 EMEA

Antenna Type	Antenna Part Number	Antenna connector (Number of ports)	AP to Antenna adaptor (Note 1,2)	Max Gain (dBi)			Azimuth beamwidth (approx)	Elevation beamwidth (approx)	Country		
				2.4GHz	4.9GHz	5GHz					
									EU		
Dipole	ML-2499-FHPA5-01R	N male		5				360	25		
	ML-2499-HPA3-02R	RP SMA male		5				360	32		
	ML-2499-HPA8-01	N male		8				360	14		
	ML-5299-APA1-01R	RP SMA male				4		360	60		
	ML-5299-FHPA6-01R	N male			8.25	8.25		360	16		
	ML-5299-HPA5-01	N male				5.6		360	22		
	ML-5299-HPA10-01	N male			10.5	10.5		360	8		
	ML-2452-APA2-01	RP SMA male	*		3.17	4.9		360	45	Y	
	ML-2452-APA2-02	RP SMA male	*		3.17	4.9		360	45	Y	
	ML-2452-APAG2A1-01	RP SMA male	*		2.7	2	2	360	60	Y	
	ML-2452-APAG2A1-02	RP SMA male	*		2.7	2	2	360	60	Y	
	ML-2452-HPA5-036	RP SMA male	*		3		5	360	50	Y	
	ML-2452-HPA6-01	N male	7		5.3	4.6	6.1	360	30	Y	
	ML-2452-HPA6M6-072	RP SMA male	7		2.8		6.5	360	66	Y	
	ML-2452-HPA6X6-036	N male (6)	7		4	6	6	360	45	Y	
	ML-2452-HPA6X6-01	N male	7		4		7.3	360	18	Y	
	ML-2452-VMM3M3-036	RP SMA male (3)	7		4.5	5.4	5.4	360	40	Y	
	ML-2452-VMM5M3-N72	N male (3)	7		4.5	5.4	5.4	360	40	Y	
	Panel	ML-2452-PNA5-01R	N male	7		5.5	6	6	120	60	Y
		ML-2452-PNA7-01R	N male			8	12	12	68	66	
ML-2452-PTA6M6-036		RP SMA male (6)	*		5	6	6	360	55	Y	
Patch	ML-2452-PTA4M4-036	RP SMA male (4)			5.5	6	5	360	70		
	ML-2452-PTA2M2-036	RP SMA male (2)	*		4	5	n/a	360	60	Y	
	ML-2452-PTA3M3-036	RP SMA male (3)			5	4	4	360	60	Y	
	ML-2452-PTA6X6-036	RP SMA male (6)			3		5	360	75		
Polarized Panel	ML-2452-SEC6M4-036	RP SMA male (4)	*		6.92	7.23	3.95	100	90	Y	
	ML-2452-PNL3M3-1	N male (3)	7		9.7	9.2	9.2	90	45	Y	
	ML-2452-HPA5A8-01	N male	7		7.5		8	360	28	Y	
	ML-2452-PNL6M3-N36	N male (3)	7		6	6	6	110	75	Y	
	ML-2452-PNL9M3-036	RP SMA male (3)	5		11	10.7	10.7	55	55	Y	
ML-2452-PNL9M3-N36	N male (3)	7		11	10.7	10.7	55	55	Y		
ML-2452-SEC6M3-N36	N male (3)	7		6.5	5	5	90	80	Y		
	N/A or No										
	Outdoor rated antenna										

AP-7522 Japan

Antenna Type	Antenna Part Number	Antenna connector (Number of ports)	AP to Antenna adapter (Note 1,2)	Max Gain (dBi)			Azimuth beamwidth (approx)	Elevation beamwidth (approx)	Country
				2.4GHz	4.9GHz	5GHz			
									Japan
Dipole	ML-2499-FHPA5-01R	N male		5			360	25	
	ML-2499-HPA3-02R	RP SMA male		5			360	32	
	ML-2499-HPA8-01	N male		8			360	14	
	ML-5299-APA1-01R	RP SMA male				4	360	60	
	ML-5299-FHPA6-01R	N male			8.25	8.25	360	16	
	ML-5299-HPA5-01	N male				5.6	360	22	
	ML-5299-HPA10-01	N male			10.5	10.5	360	8	
	ML-2452-APA2-01	RP SMA male	*	3.17		4.9	360	45	Y
	ML-2452-APA2-02	RP SMA male	*	3.17		4.9	360	45	Y
	ML-2452-APAG2A1-01	RP SMA male	*	2.7	2	2	360	60	Y
	ML-2452-APAG2A1-02	RP SMA male	*	2.7	2	2	360	60	Y
	ML-2452-HPA5-036	RP SMA male	*	3		5	360	50	Y
	ML-2452-HPA6-01	N male		5.3	4.6	6.1	360	30	
	ML-2452-HPAGM6-072	RP SMA male		2.8		6.5	360	66	
	ML-2452-HPAGX6-036	N male (6)	7	4	6	6	360	45	Y
	ML-2452-HPAG4A6-01	N male		4		7.3	360	18	
	ML-2452-HPAG5A8-01	N male		7.5		8	360	28	
	ML-2452-VMM3M3-036	RP SMA male (3)		4.5	5.4	5.4	360	40	
	ML-2452-VMM3M3-N72	N male (3)		4.5	5.4	5.4	360	40	
	Panel	ML-2452-PNA5-01R	N male	7	5.5	6	6	120	60
ML-2452-PNA7-01R		N male		8	12	12	68	66	
ML-2452-PTAGM6-036		RP SMA male (6)	*	5	6	6	360	55	Y
Patch	ML-2452-PTA4M4-036	RP SMA male (4)		5.5	6	5	360	70	
	ML-2452-PTA2M2-036	RP SMA male (2)		4	5	n/a	360	60	
	ML-2452-PTA3M3-036	RP SMA male (3)		5	4	4	360	60	
	ML-2452-PTAGX6-036	RP SMA male (6)		3		5	360	75	
Polarized Panel	ML-2452-SEC6M4-036	RP SMA male (4)		6.92	7.23	3.95	100	90	
	ML-2452-PNL3M3-1	N male (3)		9.7	9.2	9.2	90	45	
	ML-2452-PNL6M3-N36	N male (3)		6	6	6	55	55	
	ML-2452-PNL9M3-036	RP SMA male (3)		11	10.7	10.7	55	55	
	ML-2452-PNL9M3-N36	N male (3)		11	10.7	10.7	55	55	
ML-2452-SEC6M3-N36	N male (3)		6.5	5	5	90	80		
	N/A or No								
	Outdoor rated antenna								

AP-7532 North America

Antenna Type	Antenna Part Number	Antenna connector (Number of ports)	AP to Antenna adapter (Note 1,2)	Max Gain (dBi)			Elevation Gain (dBi)	Azimuth beamwidth (approx)	Elevation beamwidth (approx)	Country
				2.4GHz	4.9GHz	5GHz				
										US, Canada
Dipole	ML-2499-FHPA5-01R	N male		5			n/a	360	25	
	ML-2499-HPA3-02R	RP SMA male		5			n/a	360	32	
	ML-2499-HPA8-01	N male		8			n/a	360	14	
	ML-5299-APA1-01R	RP SMA male				4	n/a	360	60	
	ML-5299-FHPA6-01R	N male			8.25	8.25	-6.05	360	16	
	ML-5299-HPA5-01	N male				5.6	-2.5	360	22	
	ML-5299-HPA10-01	N male			10.5	10.5	na	360	8	
	ML-2452-APA2-01	RP SMA male	*	3.17		4.9	n/a	360	45	Y
	ML-2452-APA2-02	RP SMA male	*	3.17		4.9	n/a	360	45	Y
	ML-2452-APAG2A1-01	RP SMA male	*	2.7	2	2	n/a	360	60	Y
	ML-2452-APAG2A1-02	RP SMA male	*	2.7	2	2	n/a	360	60	Y
	ML-2452-HPA5-036	RP SMA male	*	3		5	-2.6	360	50	Y
	ML-2452-HPA6-01	N male		5.3	4.6	6.1	4.09	360	30	
	ML-2452-HPAGM6-072	RP SMA male		2.8		6.5	-0.56	360	66	
	ML-2452-HPAGX6-036	N male (6)	7	4	6	6	-3.9	360	45	Y
	ML-2452-HPAG4A6-01	N male		4		7.3	5.7	360	18	
	ML-2452-HPAG5A8-01	N male		7.5		8	-9.7	360	28	
	ML-2452-VMM3M3-036	RP SMA male (3)		4.5	5.4	5.4	1.3	360	40	
	ML-2452-VMM3M3-N72	N male (3)		4.5	5.4	5.4	2.9	360	40	
	Panel	ML-2452-PNA5-01R	N male	7	5.5	6	6	5.2	120	60
ML-2452-PNA7-01R		N male		8	12	12	7.5	68	66	
ML-2452-PTAGM6-036		RP SMA male (6)	*	5	6	6	na	360	55	Y
Patch	ML-2452-PTA4M4-036	RP SMA male (4)		5.5	6	5	n/a	360	70	
	ML-2452-PTA2M2-036	RP SMA male (2)		4	5	n/a	n/a	360	60	
	ML-2452-PTA3M3-036	RP SMA male (3)	*	5	4	4	n/a	360	60	Y
	ML-2452-PTAGX6-036	RP SMA male (6)		3		5	n/a	360	75	
Polarized Panel	ML-2452-SEC6M4-036	RP SMA male (4)		6.92	7.23	3.95	3.95	100	90	
	ML-2452-PNL3M3-1	N male (3)	7	9.7	9.2	9.2	9.2	90	45	Y
	ML-2452-PNL6M3-N36	N male (3)	7	6	6	6	1.2	110	75	Y
	ML-2452-PNL9M3-036	RP SMA male (3)	*	11	10.7	10.7	7.5	55	55	Y
	ML-2452-PNL9M3-N36	N male (3)	7	11	10.7	10.7	7.3	55	55	Y
ML-2452-SEC6M3-N36	N male (3)	7	6.5	5	5	3.4	90	80	Y	
Note 1										
	N/A or No									
	Outdoor rated antenna									
Note 2										
AP to antenna adapter	Description	Adapter part number								
5	RP SMA to N-male	25-90263-01R								
7	RP SMA to N-female	25-85392-01R								
*	Compatible, no adapter needed	n/a								

AP-7532 EMEA

Antenna Type	Antenna Part Number	Antenna connector (Number of ports)	AP to Antenna adapter (Note 1,2)	Max Gain (dBi)			Azimuth beamwidth (approx)	Elevation beamwidth (approx)	Country
				2.4GHz	4.9GHz	5GHz			
									EU
Dipole	ML-2499-FHPA5-01R	N male		5			360	25	
	ML-2499-HPA3-02R	RP SMA male		5			360	32	
	ML-2499-HPA8-01	N male		8			360	14	
	ML-5299-APA1-01R	RP SMA male				4	360	60	
	ML-5299-FHPA6-01R	N male			8.25		360	16	
	ML-5299-HPA5-01	N male				5.6	360	22	
	ML-5299-HPA10-01	N male			10.5		360	8	
	ML-2452-APA2-01	RP SMA male	*	3.17		4.9	360	45	Y
	ML-2452-APA2-02	RP SMA male	*	3.17		4.9	360	45	Y
	ML-2452-APAG2A1-01	RP SMA male	*	2.7	2	2	360	60	Y
	ML-2452-APAG2A1-02	RP SMA male	*	2.7	2	2	360	60	Y
	ML-2452-HPA5-036	RP SMA male	*	3		5	360	50	Y
	ML-2452-HPA6-01	N male	7	5.3	4.6		360	30	Y
	ML-2452-HPA6M6-072	RP SMA male	7	2.8		6.5	360	66	Y
	ML-2452-HPA6X6-036	N male (6)	7	4	6		360	45	Y
	ML-2452-HPAG4A6-01	N male	7	4		7.3	360	18	Y
	ML-2452-HPAG5A8-01	N male	7	7.5		8	360	28	Y
	ML-2452-VMM3M3-036	RP SMA male (3)	*	4.5	5.4	5.4	360	40	Y
	ML-2452-VMM5M3-N72	N male (3)	7	4.5	5.4	5.4	360	40	Y
	Panel	ML-2452-PNA5-01R	N male	7	5.5	6	6	120	60
ML-2452-PNA7-01R		N male		8	12	12	68	66	
ML-2452-PTA6M6-036		RP SMA male (6)	*	5	6	6	360	55	Y
Patch	ML-2452-PTA4M4-036	RP SMA male (4)		5.5	6	5	360	70	
	ML-2452-PTA2M2-036	RP SMA male (2)		4	5	n/a	360	60	
	ML-2452-PTA3M3-036	RP SMA male (3)	*	5	4	4	360	60	Y
	ML-2452-PTA6X6-036	RP SMA male (6)		3		5	360	75	
Polarized Panel	ML-2452-SEC6M4-036	RP SMA male (4)		6.92	7.23	3.95	100	90	
	ML-2452-PNL3M3-1	N male (4)		9.7	9.2	9.2	90	45	
	ML-2452-PNL6M3-N36	N male (3)	7	6	6	6	110	75	Y
	ML-2452-PNL9M3-036	RP SMA male (3)		11	10.7	10.7	55	55	
	ML-2452-PNL9M3-N36	N male (3)		11		10.7	55	55	
	ML-2452-SEC6M3-N36	N male (3)		6.5	5	5	90	80	
Note 1:									
	N/A or No								
	Outdoor rated antenna								
Note 2:									
AP to antenna adapter	Description	Adapter part number							
5	RP SMA to N-male	25-90263-01R							
7	RP SMA to N-female	25-85392-01R							
*	Compatible, no adapter needed	n/a							

AP-7532 Japan

Antenna Type	Antenna Part Number	Antenna connector (Number of ports)	AP to Antenna adapter (Note 1,2)	Max Gain (dBi)			Azimuth beamwidth (approx)	Elevation beamwidth (approx)	Country
				2.4GHz	4.9GHz	5GHz			
									Japan
Dipole	ML-2499-FHPA5-01R	N male		5			360	25	
	ML-2499-HPA3-02R	RP SMA male		5			360	32	
	ML-2499-HPA8-01	N male		8			360	14	
	ML-5299-APAI-01R	RP SMA male				4	360	60	
	ML-5299-FHPA6-01R	N male			8.25	8.25	360	16	
	ML-5299-HPA5-01	N male				5.6	360	22	
	ML-5299-HPAI0-01	N male			10.5	10.5	360	8	
	ML-2452-APA2-01	RP SMA male	*	3.17		4.9	360	45	Y
	ML-2452-APA2-02	RP SMA male	*	3.17		4.9	360	45	Y
	ML-2452-APAG2AI-01	RP SMA male	*	2.7	2	2	360	60	Y
	ML-2452-APAG2AI-02	RP SMA male	*	2.7	2	2	360	60	Y
	ML-2452-HPA5-036	RP SMA male	*	3		5	360	50	Y
	ML-2452-HPA6-01	N male		5.3	4.6	6.1	360	30	
	ML-2452-HPA6M6-072	RP SMA male		2.8		6.5	360	66	
	ML-2452-HPA6X6-036	N male (6)		7	4	6	360	45	Y
	ML-2452-HPAG4A6-01	N male		4		7.3	360	18	
	ML-2452-HPAG5A8-01	N male		7.5		8	360	28	
	ML-2452-VMM3M3-036	RP SMA male (3)		4.5	5.4	5.4	360	40	
	ML-2452-VMM5M3-N72	N male (3)		4.5	5.4	5.4	360	40	
	Panel	ML-2452-PNA5-01R	N male	7	5.5	6	6	120	60
ML-2452-PNA7-01R		N male		8	12	12	68	66	
ML-2452-PTA6M6-036		RP SMA male (6)	*	5	6	6	360	55	Y
Patch	ML-2452-PTA4M4-036	RP SMA male (4)		5.5	6	5	360	70	
	ML-2452-PTA2M2-036	RP SMA male (2)		4	5	n/a	360	60	
	ML-2452-PTA3M3-036	RP SMA male (3)		5	4	4	360	60	
	ML-2452-PTA6X6-036	RP SMA male (6)		3		5	360	75	
Polarized Panel	ML-2452-SECGM4-036	RP SMA male (4)		6.92	7.23	3.95	100	90	
	ML-2452-PNL3M3-1	N male (4)		9.7	9.2	9.2	90	45	
	ML-2452-PNL6M3-N36	N male (3)		6	6	6	110	75	
	ML-2452-PTA6M6-036	RP SMA male (6)		5	6	6	360	55	
	ML-2452-PNL9M3-036	RP SMA male (3)		11	10.7	10.7	55	55	
	ML-2452-PNL9M3-N36	N male (3)		11		10.7	55	55	
	ML-2452-SECGM3-N36	N male (3)		6.5	5	5	90	80	
Note 1:									
	N/A or No								
	Outdoor rated antenna								
Note 2:									
AP to antenna adapter	Description	Adapter part number							
5	RP SMA to N-male	25-90263-01R							
7	RP SMA to N-female	25-85392-01R							
*	Compatible, no adapter needed	n/a							

AP-7562 North America

Antenna Type	Antenna Part Number	Antenna connector (Number of ports)	AP to Antenna adapter (Note 1,2)	Max Gain (dBi)			Elevation Gain (dBi)	Azimuth beamwidth (approx)	Elevation beamwidth (approx)	Country	
				2.4GHz	4.9GHz	5GHz	5GHz				
										US, Canada	
Dipole	ML-2499-FHPA5-01R	N male	*	5			n/a	360	25	Y	
	ML-2499-HPA3-02R	RP SMA male	5	5			n/a	360	32	Y	
	ML-2499-HPA8-01	N male		8			n/a	360	14		
	ML-5299-APAI-01R	RP SMA male	5		4		n/a	360	60	Y	
	ML-5299-FHPA6-01R	N male			8.25	8.25	-6.05	360	16		
	ML-5299-HPA5-01	N male					5.6	360	22		
	ML-5299-HPAI0-01	N male			10.5	10.5	-10.5	360	8		
	ML-2452-APA2-01	RP SMA male			3.17		4.9	n/a	360	45	
	ML-2452-APA2-02	RP SMA male			3.17		4.9	n/a	360	45	
	ML-2452-APAG2A1-01	RP SMA male			2.7	2	2	n/a	360	60	
	ML-2452-APAG2A1-02	RP SMA male		5	2.7	2	2	n/a	360	60	
	ML-2452-HPA5-036	RP SMA male		5	3		5	-2.6	360	50	
	ML-2452-HPA6-01	N male	*		5.3	4.6	6.1	4.09	360	30	
	ML-2452-HPA6M6-072	RP SMA male		5	2.8		6.5	-0.56	360	66	
	ML-2452-HPA6X6-036	N male (6)		7	4		6	-3.9	360	45	
	ML-2452-HPA64A6-01	N male	*		4		7.3	5.7	360	18	
	ML-2452-HPA65A8-01	N male	*		5		8	-9.7	360	28	
	ML-2452-VMM3M3-036	RP SMA male (3)		5	4.5	5.4	5.4	1.3	360	40	
	ML-2452-VMM5M3-N72	N male (3)	*		4.5	5.4	5.4	2.9	360	40	
	Panel	ML-2452-PNA5-01R	N male	*	5.5	6	6	5.2	120	60	Y
		ML-2452-PNA7-01R	N male		8	12	12	7.5	68	66	
		ML-2452-PTA6M6-036	RP SMA male (6)	5	5	6	6	na	360	55	Y
	Patch	ML-2452-PTA4M4-036	RP SMA male (4)		5.5	6	5	n/a	360	70	
ML-2452-PTA2M2-036		RP SMA male (2)		4	5	n/a	n/a	360	60		
ML-2452-PTA3M3-036		RP SMA male (3)		5	4	4	n/a	360	60		
ML-2452-PTA6X6-036		RP SMA male (6)		3		5	n/a	360	75		
Polarized Panel	ML-2452-SEC6M4-036	RP SMA male (4)		6.92	7.23	3.95	3.95	100	90		
	ML-2452-PNL3M3-1	N male (3)	*	9.7	9.2	9.2	9.2	90	45	Y	
	ML-2452-PNL6M3-N36	N male (3)	*	6	6	6	1.2	110	75	Y	
	ML-2452-PNL9M3-036	RP SMA male (3)	5	11	10.7	10.7	7.5	55	55	Y	
	ML-2452-PNL9M3-N36	N male (3)	*	11	10.7	10.7	7.3	55	55	Y	
	ML-2452-SEC6M3-N36	N male (3)	*	6.5	5	5	3.4	90	80	Y	
Note 1:											
	N/A or No										
	Outdoor rated antenna										
Note 2:											
	AP to antenna adapter	Description	Adapter part number								
	5	RP SMA to N-male	25-90263-01R								
	7	RP SMA to N-female	25-85392-01R								
	*	Compatible, no adapter needed	n/a								

AP-7562 EMEA

Antenna Type	Antenna Part Number	Antenna connector (Number of ports)	AP to Antenna adapter (Note 1,2)	Max Gain (dBi)			Azimuth beamwidth (approx)	Elevation beamwidth (approx)	Country	
				2.4GHz	4.9GHz	5GHz				
									EU	
Dipole	ML-2499-FHPA5-01R	N male	*	5			360	25	Y	
	ML-2499-HPA3-02R	RP SMA male	5	5			360	32	Y	
	ML-2499-HPA8-01	N male	*	8			360	14	Y	
	ML-5299-APA1-01R	RP SMA male	5			4	360	60	Y	
	ML-5299-FHPA6-01R	N male	*		8.25	8.25	360	16	Y	
	ML-5299-HPA5-01	N male	*				5.6	360	22	Y
	ML-5299-HPA10-01	N male	*		10.5	10.5	360	8	Y	
	ML-2452-APA2-01	RP SMA male			3.17			4.9	360	45
	ML-2452-APA2-02	RP SMA male			3.17			4.9	360	45
	ML-2452-APAG2A1-01	RP SMA male			2.7	2	2	360	60	
	ML-2452-APAG2A1-02	RP SMA male			2.7	2	2	360	60	
	ML-2452-HPA5-036	RP SMA male	5	3			5	360	50	Y
	ML-2452-HPA6-01	N male	*		5.3	4.6	6.1	360	30	Y
	ML-2452-HPA6M6-072	RP SMA male	5	2.8			6.5	360	66	Y
	ML-2452-HPA6X6-036	N male (6)	7	4	4	6	6	360	45	Y
	ML-2452-HPAG4A6-01	N male	*		4		7.3	360	18	Y
	ML-2452-HPAG5A8-01	N male	*		5		8	360	28	Y
	ML-2452-VMM3M3-036	RP SMA male (3)	5	4.5	5.4	5.4	360	40	Y	
	ML-2452-VMM5M3-N72	N male (3)	*	4.5	5.4	5.4	360	40	Y	
	Panel	ML-2452-PNA7-01R	N male	*	5.5	6	6	120	60	Y
ML-2452-PNA7-01R		N male	*	8	12	12	68	66	Y	
Patch	ML-2452-PTA6M6-036	RP SMA male (6)		5	6	6	360	55		
	ML-2452-PTA4M4-036	RP SMA male (4)		5.5	6	5	360	70		
	ML-2452-PTA2M2-036	RP SMA male (2)		4	5	n/a	360	60		
	ML-2452-PTA3M3-036	RP SMA male (3)		5	4	4	360	60		
Polarized Panel	ML-2452-PTA6X6-036	RP SMA male (6)		3		5	360	75		
	ML-2452-SEC6M4-036	RP SMA male (4)	5	6.92	7.23	3.95	100	90	Y	
	ML-2452-PNL3M3-1	N male (3)	*	9.7	9.2	9.2	90	45	Y	
	ML-2452-PNL6M3-N36	N male (3)	*	6	6	6	110	75	Y	
	ML-2452-PNL9M3-036	RP SMA male (3)		11	10.7	10.7	55	55		
ML-2452-PNL9M3-N36	N male (3)		11		10.7	55	55			
ML-2452-SEC6M3-N36	N male (3)	*	6.5	5	5	90	80	Y		
Note 1:										
	N/A or No									
	Outdoor rated antenna									
Note 2:										
AP to antenna adapter	Description	Adapter part number								
5	RP SMA to N-male	25-90263-01R								
7	RP SMA to N-female	25-85392-01R								
*	Compatible, no adapter needed	n/a								

AP-7562 Japan

Antenna Type	Antenna Part Number	Antenna connector (Number of ports)	AP to Antenna adapter (Note 1,2)	Max Gain (dBi)			Azimuth beamwidth (approx)	Elevation beamwidth (approx)	Country	
				2.4GHz	4.9GHz	5GHz				
									Japan	
Dipole	ML-2499-FHPA5-01R	N male	*	5			360	25	Y	
	ML-2499-HPA3-02R	RP SMA male	5	5			360	32	Y	
	ML-2499-HPA8-01	N male	*	8			360	14	Y	
	ML-5299-APA1-01R	RP SMA male	5			4	360	60	Y	
	ML-5299-FHPA6-01R	N male	*			8.25	8.25	360	16	Y
	ML-5299-HPA5-01	N male	*				5.6	360	22	Y
	ML-5299-HPA10-01	N male	*			10.5	10.5	360	8	Y
	ML-2452-APA2-01	RP SMA male			3.17		4.9	360	45	
	ML-2452-APA2-02	RP SMA male			3.17		4.9	360	45	
	ML-2452-APAG2A1-01	RP SMA male			2.7	2	2	360	60	
	ML-2452-APAG2A1-02	RP SMA male			2.7	2	2	360	60	
	ML-2452-HPA5-036	RP SMA male	5	3	3		5	360	50	Y
	ML-2452-HPA6-01	N male	*		5.3	4.6	6.1	360	30	Y
	ML-2452-HPA6M6-072	RP SMA male	5	2.8			6.5	360	66	Y
	ML-2452-HPA6X6-036	N male (6)	7	4	4	6	6	360	45	Y
	ML-2452-HPAG4A6-01	N male	*		4		7.3	360	18	Y
	ML-2452-HPAG5A8-01	N male	*		5		8	360	28	Y
	ML-2452-VMM3M3-036	RP SMA male (3)	5	4.5	5.4	5.4	5.4	360	40	Y
ML-2452-VMM5M3-N72	N male (3)	*		4.5	5.4	5.4	360	40	Y	
Panel	ML-2452-PNA5-01R	N male	*		5.5	6	6	120	60	Y
	ML-2452-PNA7-01R	N male	*		8	12	12	68	66	Y
Patch	ML-2452-PTA6M6-036	RP SMA male (6)			5	6	6	360	55	
	ML-2452-PTA4M4-036	RP SMA male (4)			5.5	6	5	360	70	
	ML-2452-PTA2M2-036	RP SMA male (2)			4	5	n/a	360	60	
	ML-2452-PTA3M3-036	RP SMA male (3)			5	4	4	360	60	
Polarized Panel	ML-2452-PTA6X6-036	RP SMA male (6)			3		5	360	75	
	ML-2452-SEC6M4-036	RP SMA male (4)	5	6.92	7.23	3.95	100	90	Y	
	ML-2452-PNL3M3-1	N male (3)	*		9.7	9.2	9.2	90	45	Y
	ML-2452-PNL6M3-N36	N male (3)	*		6	6	6	110	75	Y
	ML-2452-PNL9M3-036	RP SMA male (3)			11	10.7	10.7	55	55	
	ML-2452-PNL9M3-N36	N male (3)			11		10.7	55	55	
	ML-2452-SEC6M3-N36	N male (3)	*		6.5	5	5	90	80	Y
Note 1:										
	N/A or No									
	Outdoor rated antenna									
Note 2:										
AP to antenna adapter	Description	Adapter part number								
5	RP SMA to N-male	25-90263-01R								
7	RP SMA to N-female	25-85392-01R								
*	Compatible, no adapter needed	n/a								

3 2.4 GHz Single Band Antenna Suite

ML-2499-HPA3-02R Dipole Omni Antenna: RP-SMA Male
ML-2499-FHPA5-01R Omni-Directional "Pipe" Antenna: N Male Connector
ML-2499-HPA4-01 Outdoor Dipole Omni Antenna: N Male Connector
ML-2499-HPA8-01 Outdoor Dipole Omni Antenna: N Male Connector
RAN405A-01R 802.11BGN, Dipole Omni, DT, 7dBi, LP, N-Type-M

Numerous single-band 2.4 GHz 802.11b/g/n antennas are supported to suit the requirements of your unique access point or access port deployment. Check the Support site periodically, as newly supported 802.11b/g/n antennas will be added to this document as they are released.

ML-2499-HPA3-02R Dipole Omni Antenna: RP-SMA Male

Type	Dipole Omni
Frequency	2400-2500 MHz
Max/Typical Gain (dBi)	5.0/3.0
Polarization	Linear, Vertical
Azimuth	3dB Beamwidth: 360°
Elevation	3dB Beamwidth: 32°
Cable Length (in.)	48
Cable Type	RG-58 Ultralink
Connector Type	RP-SMA Male
Weight	0.3 lbs
Plenum Antenna	No
Plenum Cable	Yes
Outdoor Rated	Yes (in a cable down orientation)
Storage Temp Range (C)	-30 / +70
Operation Temp Range (C)	-30 / +70

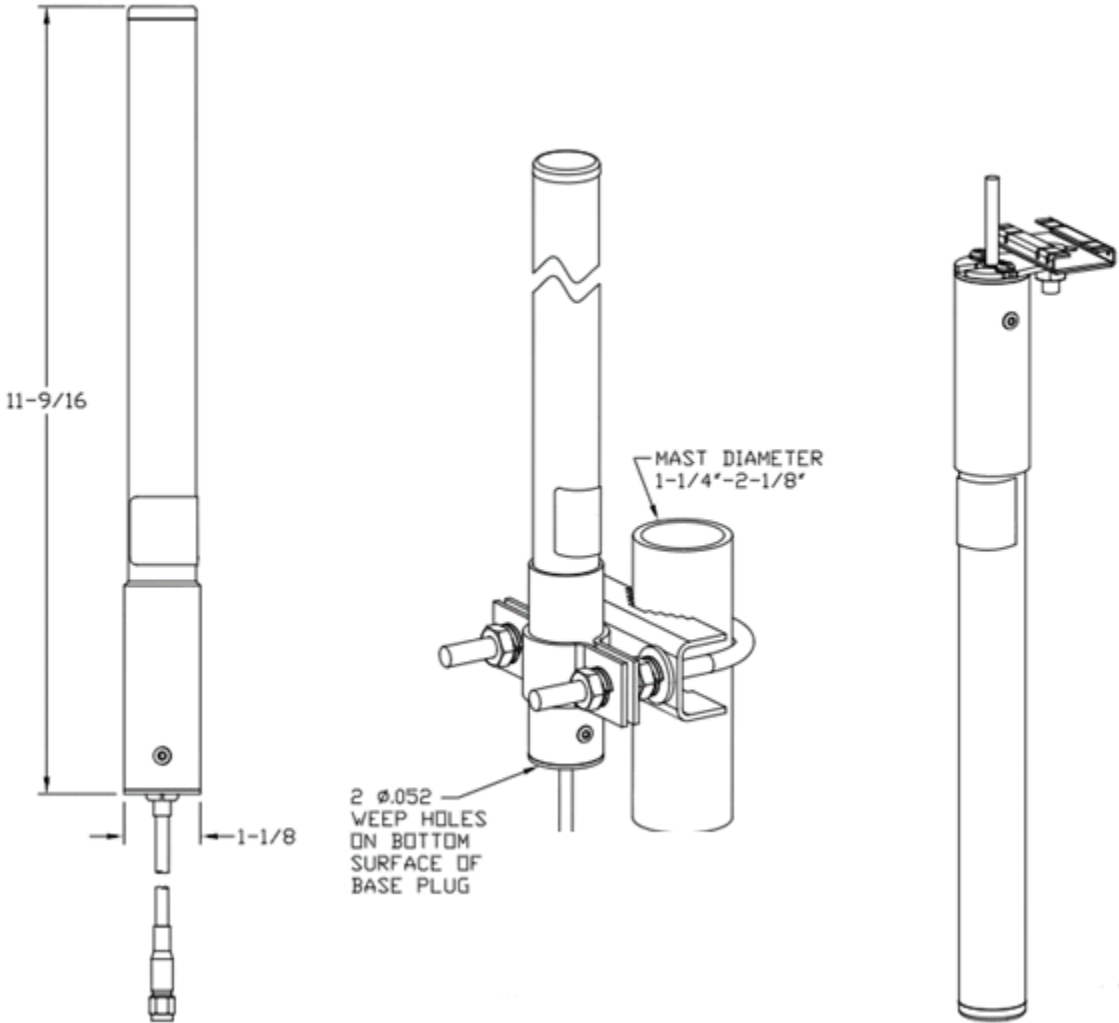

Model: Cut: Pol:

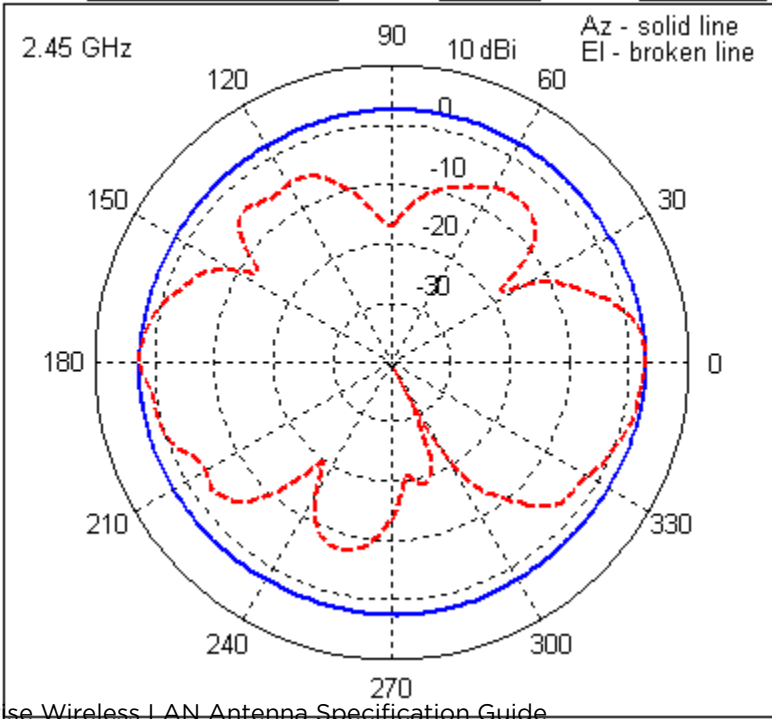

ML-2499-FHPA5-01R Omni-Directional "Pipe" Antenna: N Male Connector

Type	Dipole Omni
Frequency	2400-2500 MHz
Gain (dBi)	5
Polarization	Linear, Vertical
Azimuth	3dB Beamwidth: 360°
Elevation	3dB Beamwidth: 25°
Cable Length (in.)	N/A
Cable Type	N/A
Connector Type	Type N Male
Weight	0.7 lbs
Plenum Antenna	No
Plenum Cable	N/A
Outdoor Rated	Yes
Storage Temp Range (C)	-40 / +85
Operation Temp Range (C)	-30 / +70

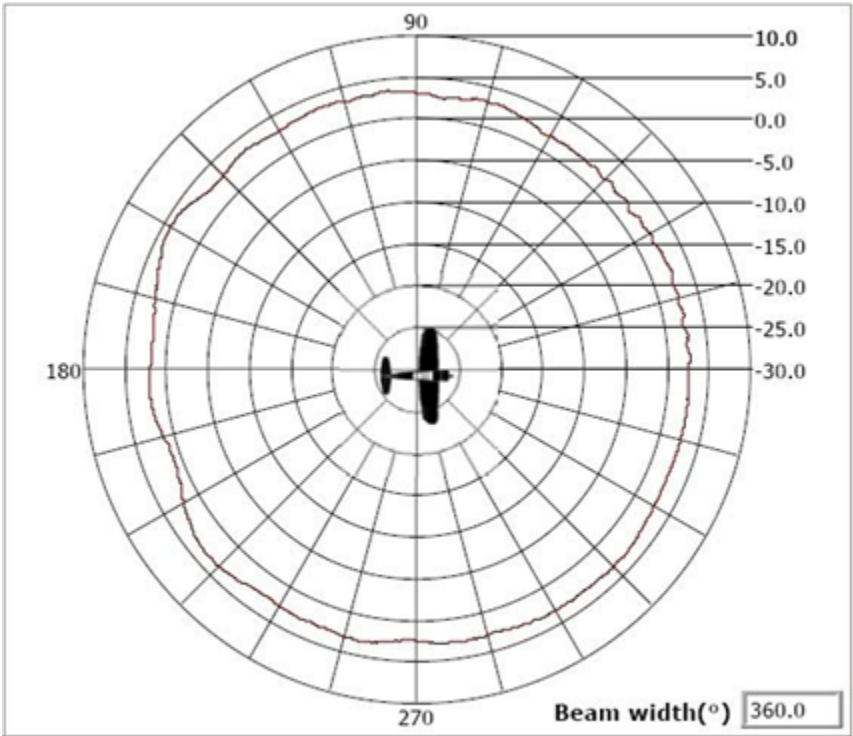
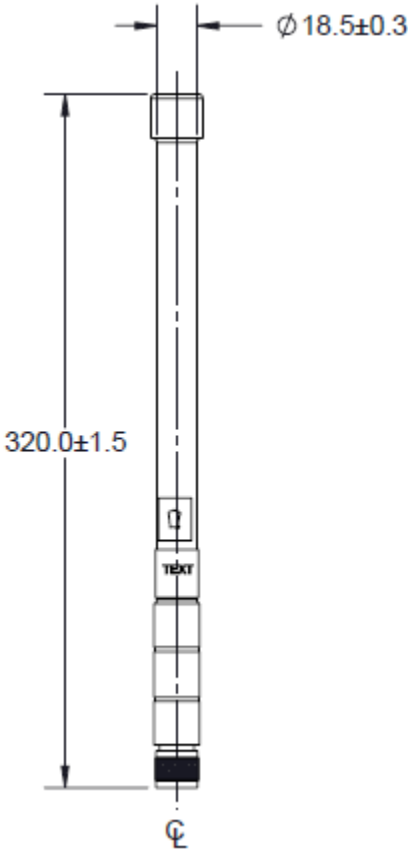

Azimuth Pattern 2450 MHz



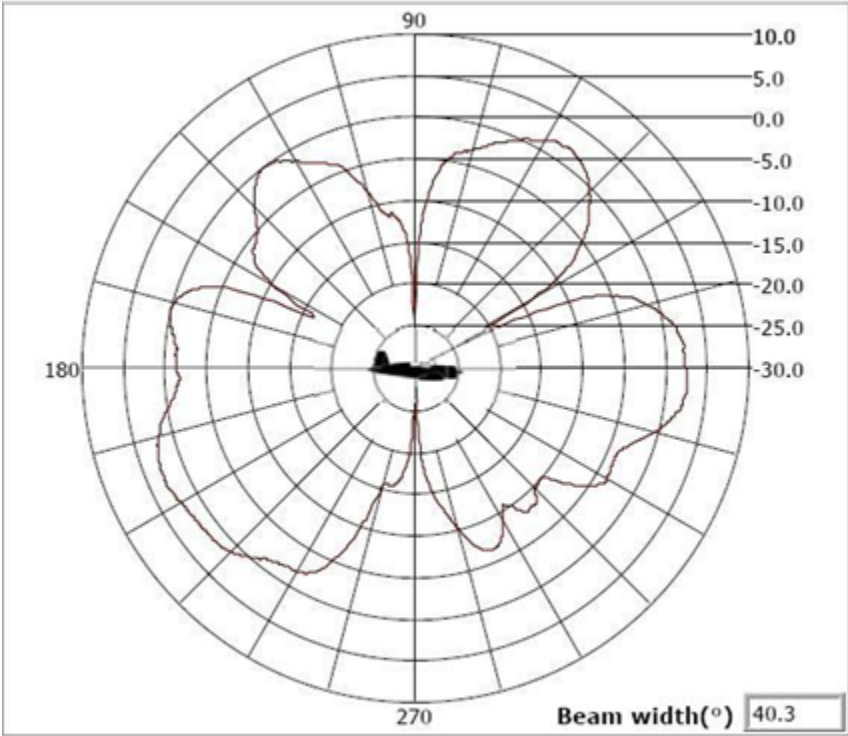

Elevation Pattern 2450 MHz



ML-2499-HPA4-01 Outdoor Dipole Omni Antenna: N Male Connector

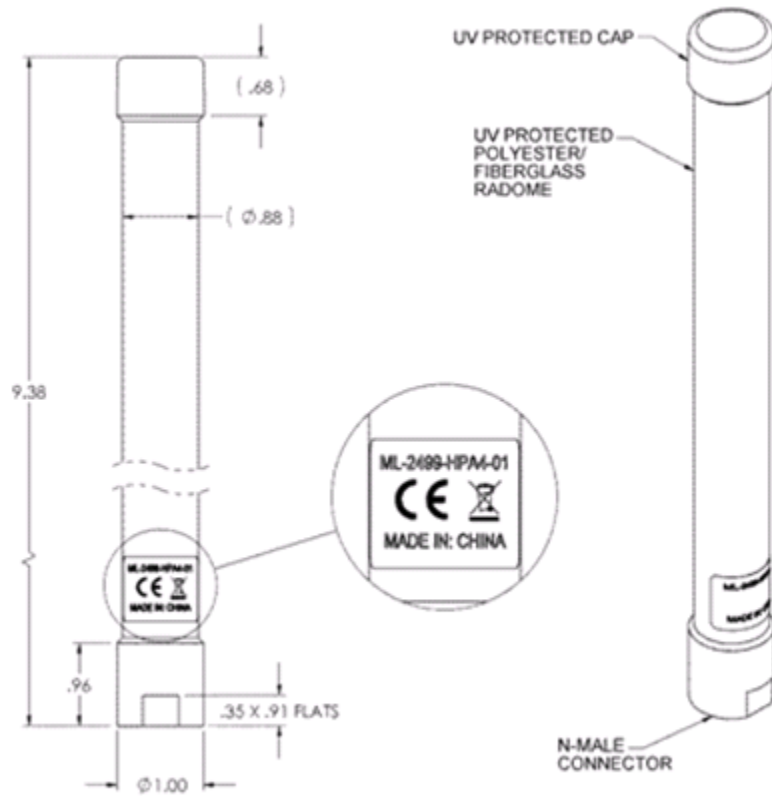

Type	Dipole, Omni
Frequency	2400-2500 MHz
Max/Typical Gain (dBi)	4.5/3.5
Polarization	Linear, Vertical
Azimuth	3dB Beamwidth: 360°
Elevation	3dB Beamwidth: 42°
Cable Length (in.)	n/a
Cable Type	n/a
Connector Type	N-Type Male
Weight	0.26 lbs
Plenum Antenna	No
Plenum Cable	n/a
Outdoor Rated	Yes

Storage Temperature Range (°C)	-40 / +85
Operation Temperature Range (°C)	-40 / +85

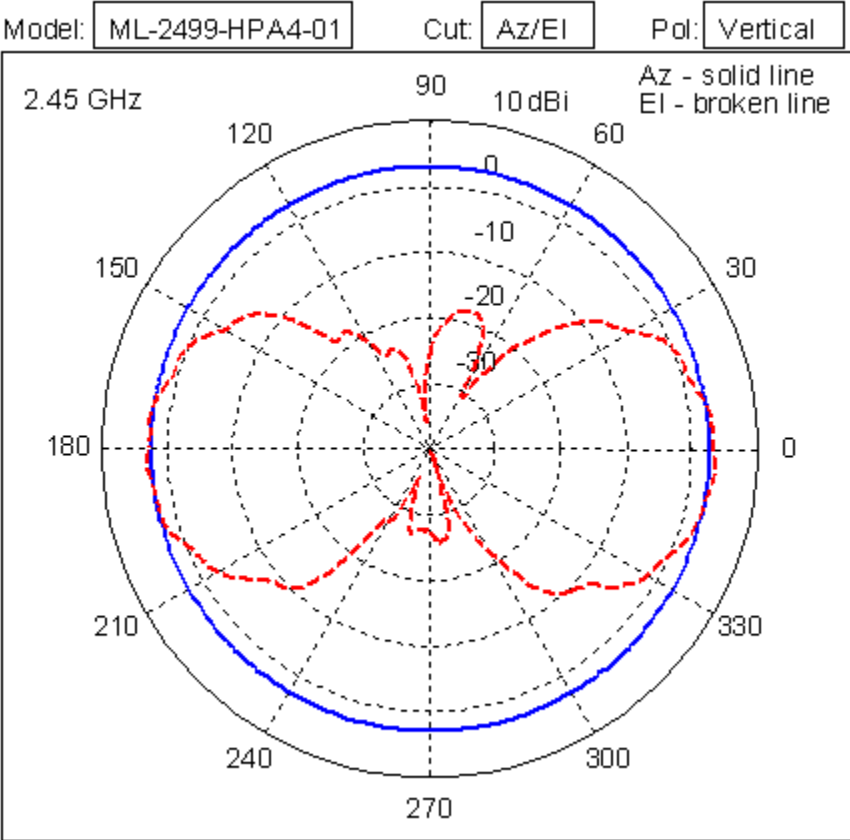

ML-2499-HPA8-01 Outdoor Dipole Omni Antenna: N Male Connector

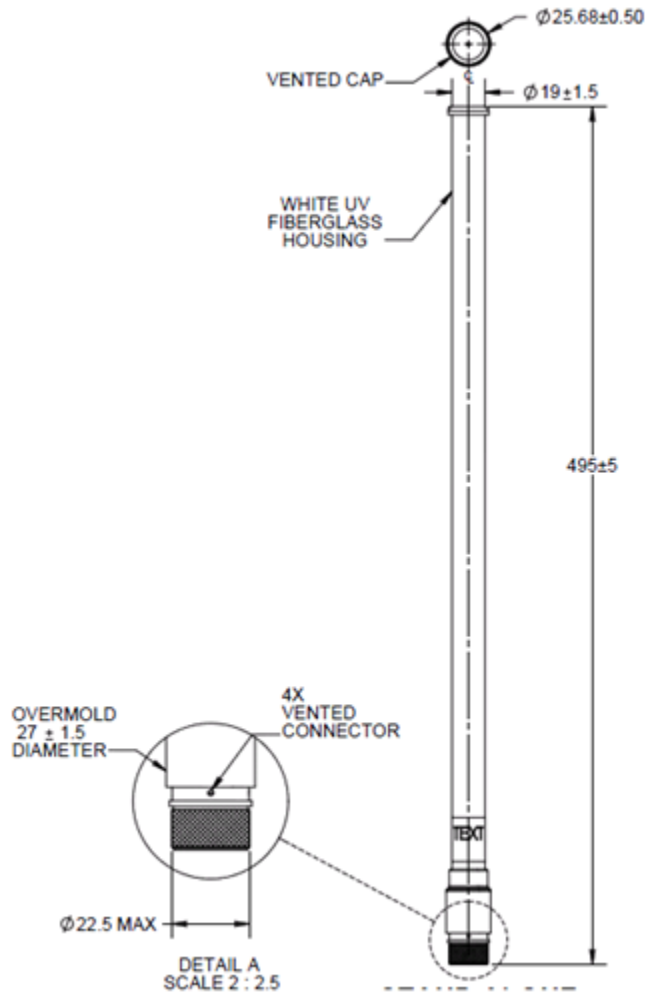

Type	Dipole, Omni
Frequency	2400-2500 MHz
Max/Typical Gain (dBi)	8.0/7.0
Polarization	Linear, Vertical
Azimuth	3dB Beamwidth: 360°
Elevation	3dB Beamwidth: 14°
Cable Length (in.)	n/a
Cable Type	n/a
Connector Type	N-Type Male
Weight	0.45 lbs
Plenum Antenna	No
Plenum Cable	n/a

Outdoor Rated	Yes
Storage Temperature Range (C)	-40 / +85
Operation Temperature Range (C)	-30 / +70

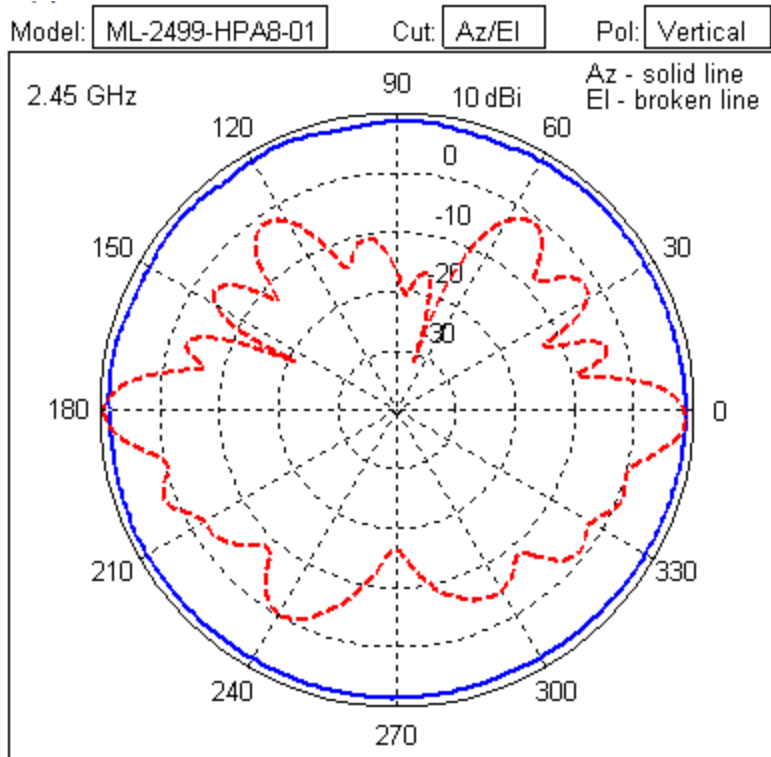

RAN405A-01R 802.11BGN, Dipole Omni, DT, 7dBi, LP, N-Type-M

Type	Dipole, Omni
Frequency	2400-2500 MHz
Max/Typical Gain (dBi)	7.15/ 7.0
Polarization	Vertical
Azimuth	3dB Beamwidth: 360°
Elevation	3dB Beamwidth: 14°
Cable Length (in.)	n/a
Cable Type	n/a
Connector Type	N-Type Male, Fixed
Weight	0.5 lbs
Plenum Antenna	No
Plenum Cable	No
Outdoor Rated	Yes

Storage Temperature Range (C)	-45/ +70
Operation Temperature Range (C)	-40 / +70

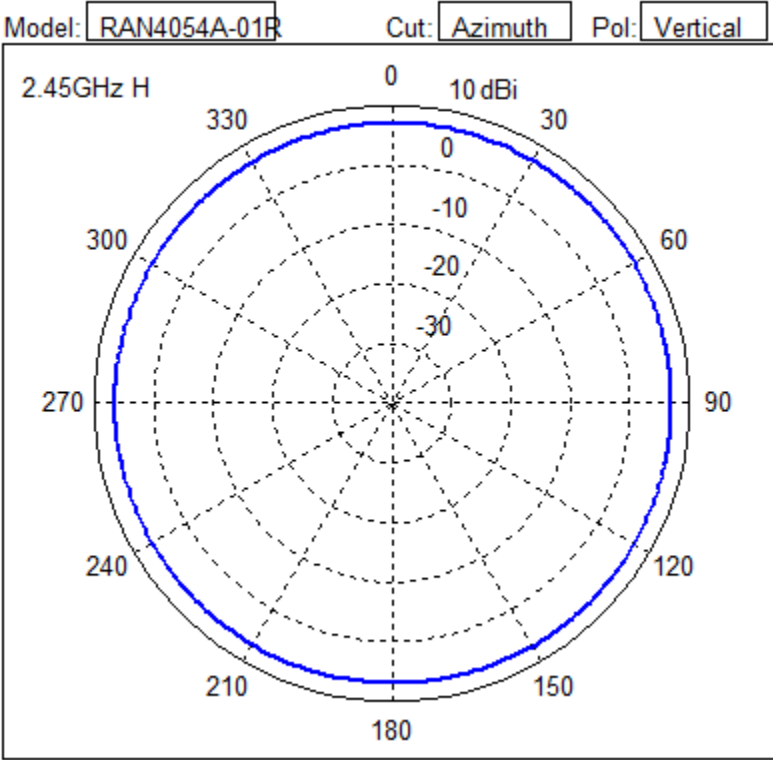
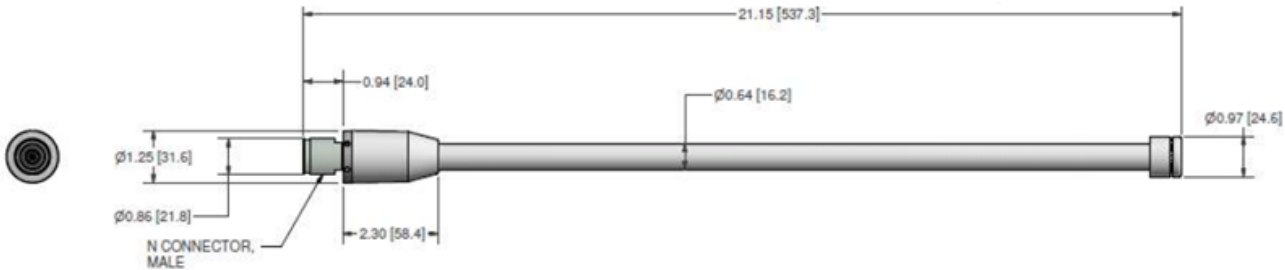

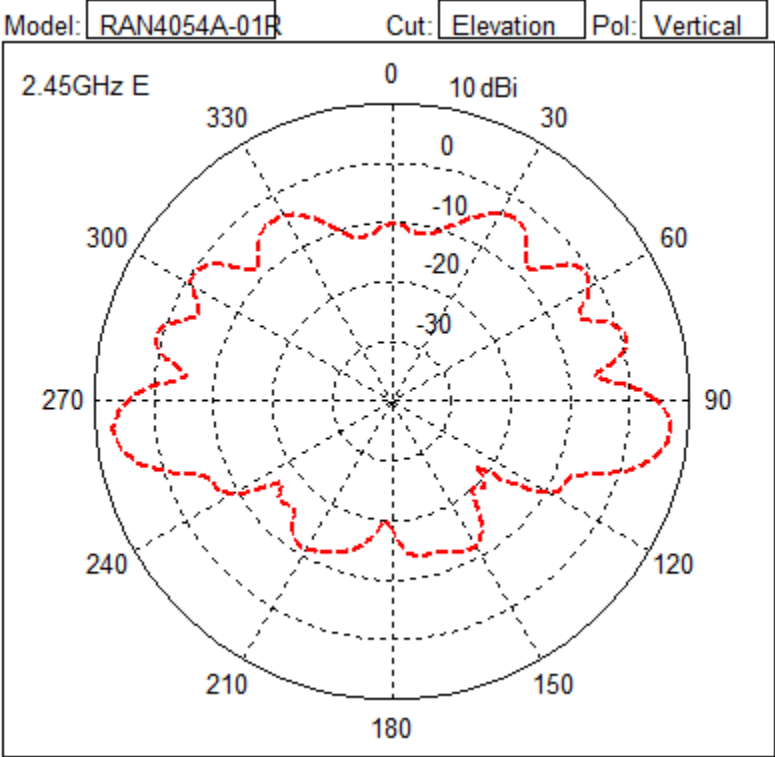

4 5.2 GHz Single Band Antenna Suite

Supported 802.11a/n Antenna Suite

Supported 802.11a/n Antenna Suite

Numerous 802.11a/n antennas are supported to suit the requirements of your unique access point deployment. Check the Support site periodically, as newly supported 802.11a/n antennas will be added to this document as they are released.

ML-5299-APA1-01R Indoor Rubber Flex Jointed Dipole: RP-SMA Male Connector

Type	Dipole
Frequency	5150-5350, 5725-5875
Max/Typical Gain (dBi)	4.0/3.0
Polarization	Linear, Vertical
Azimuth	3dB Beamwidth: 360°
Elevation	3dB Beamwidth: 60°
Cable Length (in.)	N/A
Cable Type	N/A
Connector Type	RP-SMA Male
Weight	0.3 lb
Plenum Antenna	No
Plenum Cable	N/A
Outdoor Rated	No
Storage Temp Range (C)	-30 / +85
Operation Temp Range (C)	-20 / +75

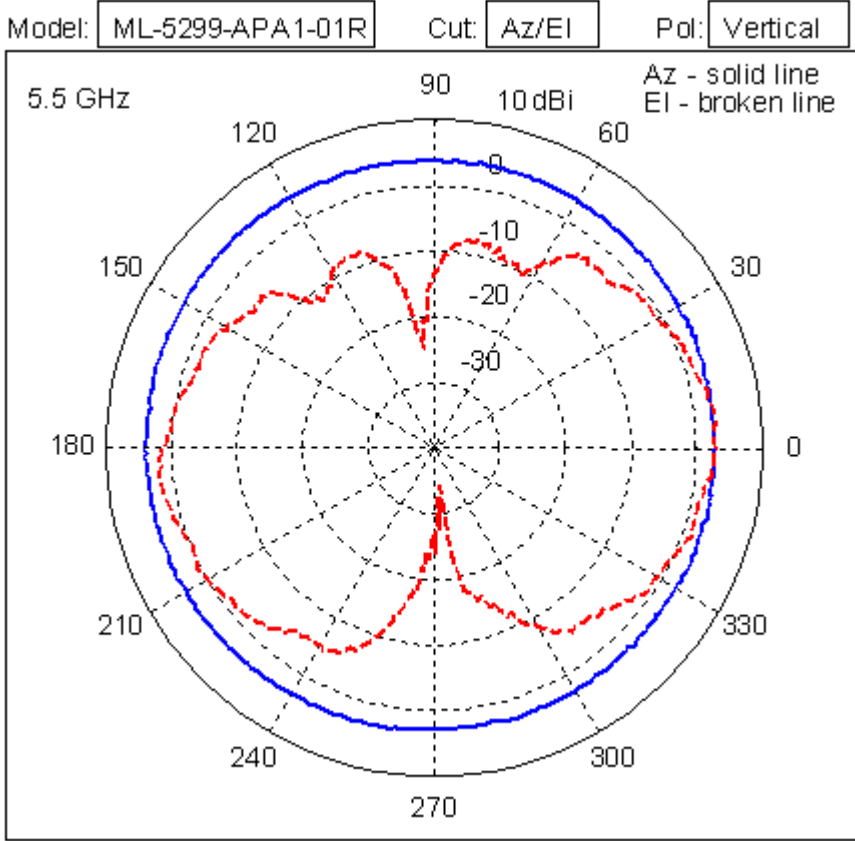
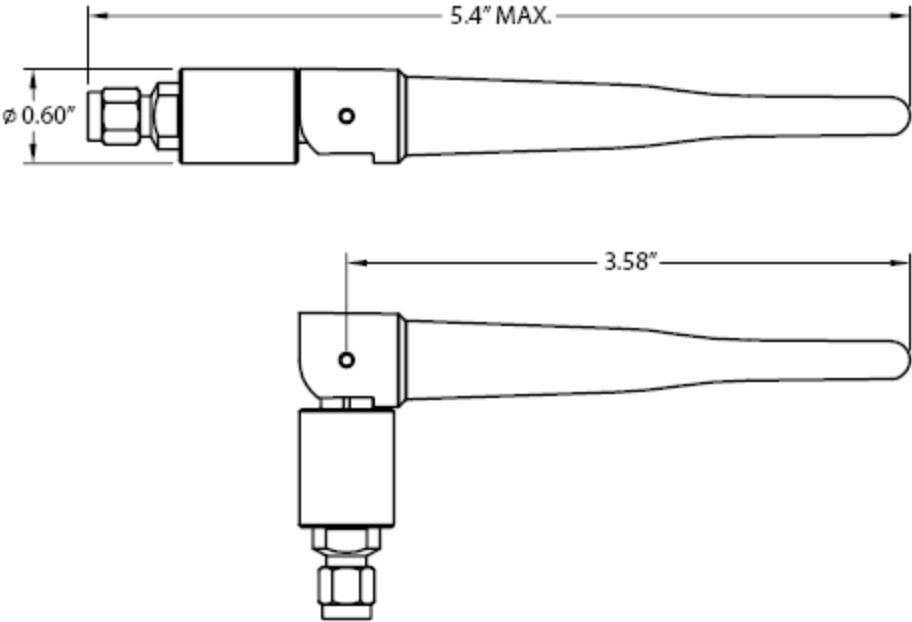

ML-5299-HPA1-01R High Performance Omni-Directional Dipole Antenna: RP-SMA Male Connector

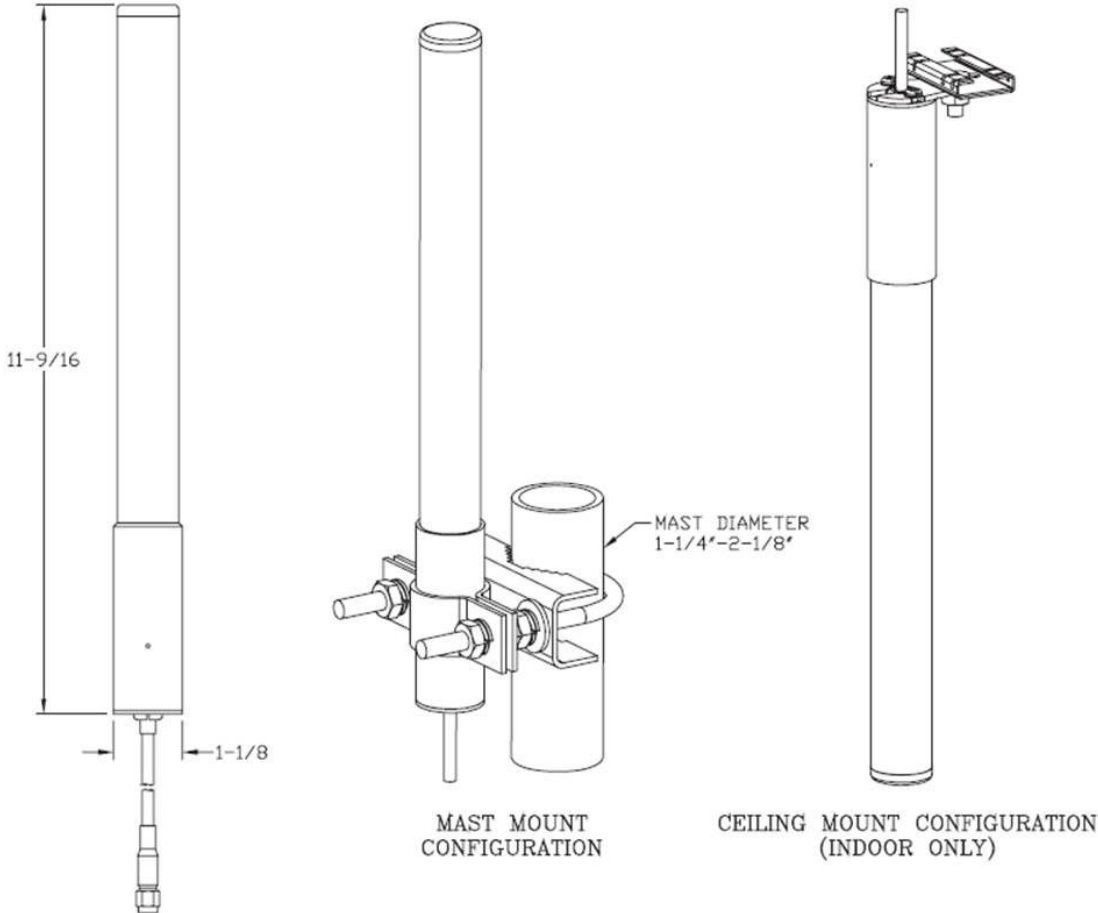

Type	Dipole
Frequency	4900-5875
Max/Typical Gain (dBi)	6.0
Polarization	Linear, Vertical
Max UNII-1 Band Elevation Gain (dBi)	-15
Azimuth	3dB Beamwidth: 360°
Elevation	3dB Beamwidth: 17°
Cable Length (in.)	36
Cable Type	LMR195
Antenna Plenum Rated	No
Outdoor Rated	Yes (cable down orientation only)
Weight	0.3



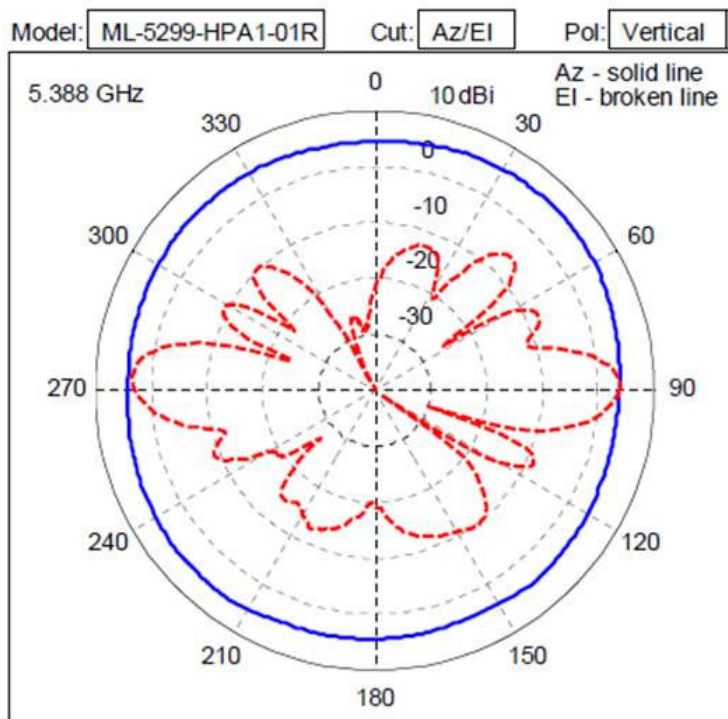

ML-5299-FHPA6-01R Omni-Directional “Pipe” Antenna: N-Male Connector

Type	Dipole Array
Frequency	4900-5875
Max/Typical Gain (dBi)	8.25/7.5
Polarization	Linear, Vertical
Azimuth	3dB Beamwidth: 360°
Elevation	3dB Beamwidth: 16°
Max UNII-1 Elevation Gain (dBi)	-6.05
Cable Length (in.)	N/A
Cable Type	N/A
Connector Type	Type N Male
Weight	0.37 lb
Plenum Antenna	No
Plenum Cable	N/A
Outdoor Rated	Yes
Storage Temp Range (C)	-40 / +85
Operation Temp Range (C)	-30 / +70

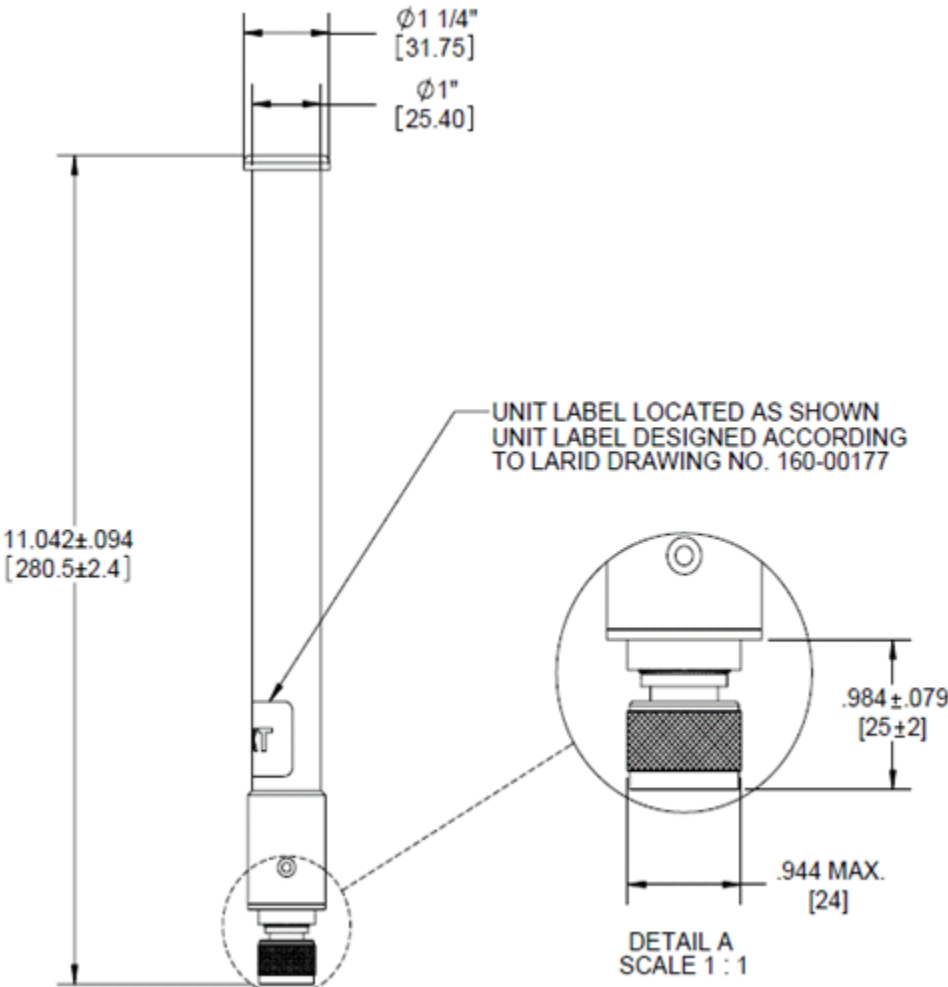

Model: Cut: Pol:

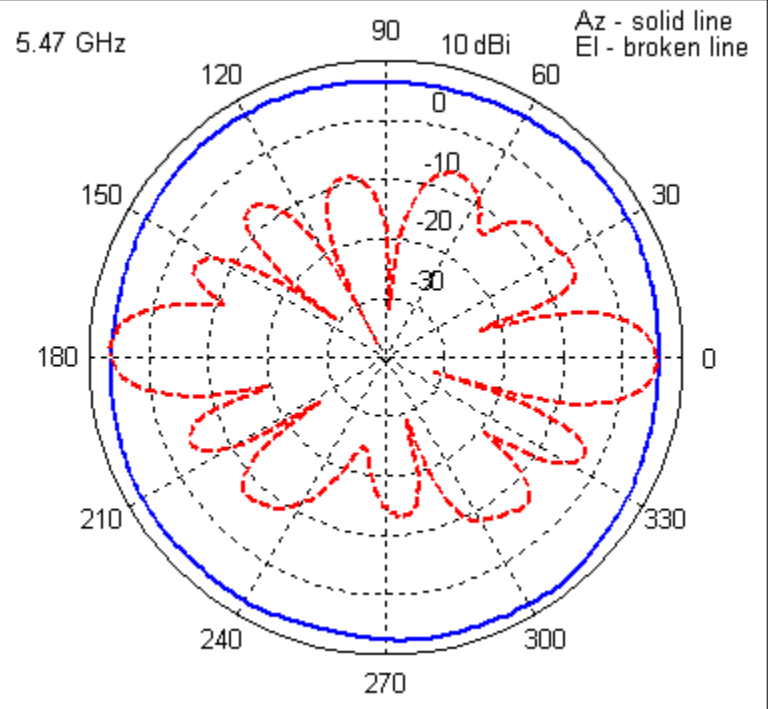

ML-5299-HPA5-01 Outdoor Dipole Omni N-Male

Type	Dipole Omni
Frequency	5150-5850
Max/Typical Gain (dBi)	5.6/4.4
Elevation Gain (dBi)	-2.5
Polarization	Linear, Vertical
Azimuth	3dB Beamwidth: 360°
Elevation	3dB Beamwidth: 22°
Max UNII-1 Elevation Gain (dBi)	-2.5
Cable Length (in.)	n/a
Cable Type	n/a
Connector Type	N-Type Male
Weight	73.8 grams
Plenum Antenna	No
Plenum Cable	n/a
Outdoor Rated	Yes
Storage Temp Range (C)	-40 / +85
Operation Temp Range (C)	-40 / +85

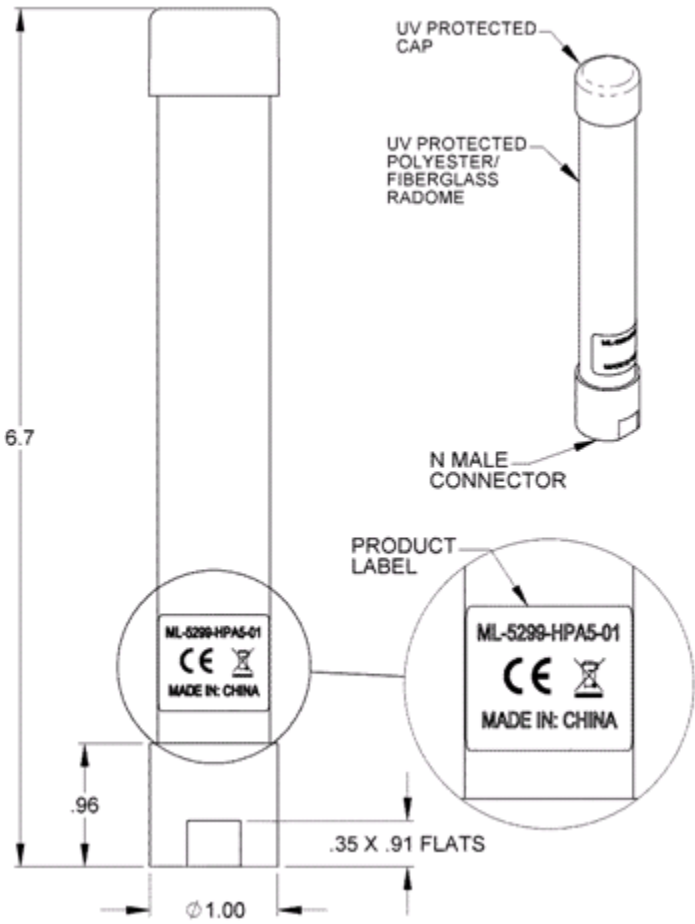

Model: **ML-5299-HPA5-01** Cut: **Az/EI** Pol: **Vertical**

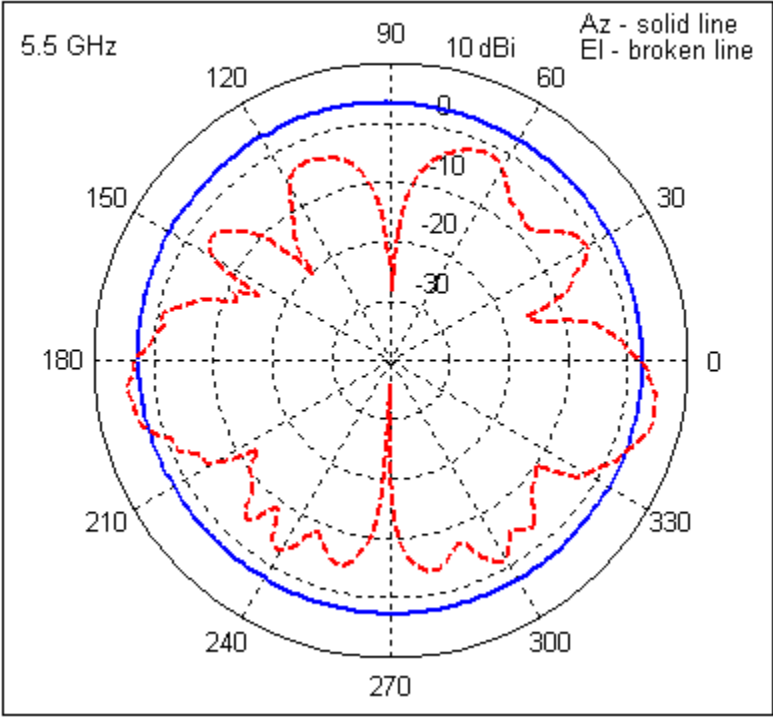

ML-5299-HPA10-01 Outdoor Dipole Omni N-Male

Type	Dipole Omni
Frequency	4900-5875
Gain (dBi)	10.5
Polarization	Linear, Vertical
Azimuth	3dB Beamwidth: 360°
Elevation	3dB Beamwidth: 8°
Cable Length (in.)	n/a
Cable Type	n/a
Connector Type	N-Type Male
Weight	0.4 lbs
Plenum Antenna	No
Plenum Cable	n/a
Outdoor Rated	Yes
Storage Temp Range (C)	-40 / +85
Operation Temp Range (C)	-30 / +70



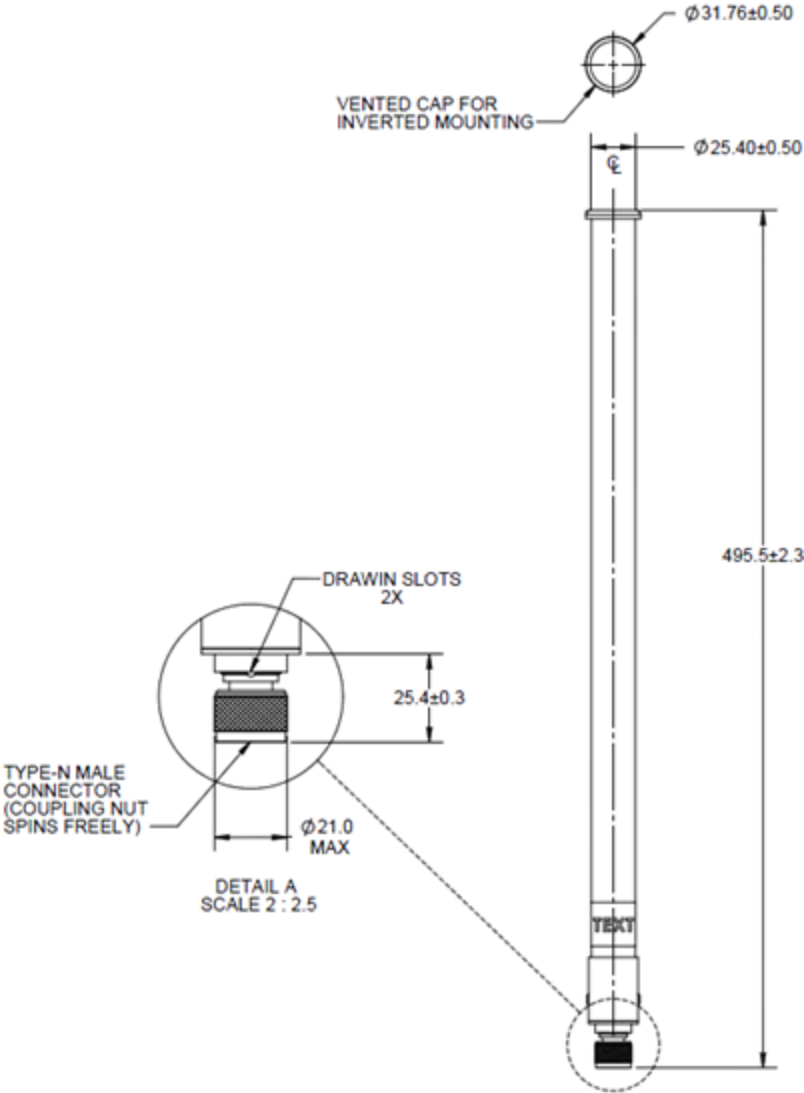

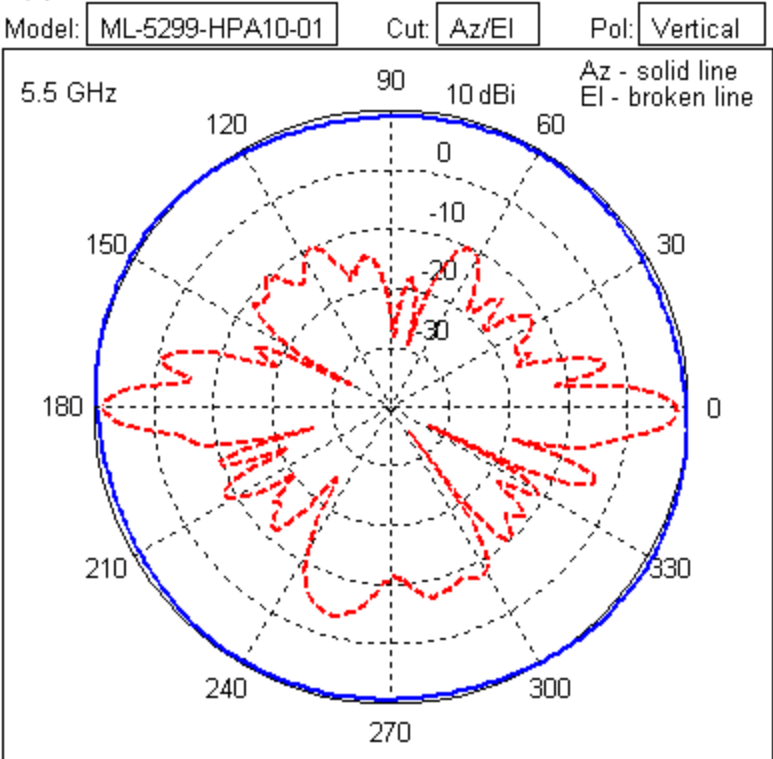

5 2.4 GHz - 5.2 GHz Dual Band Antenna Suite

ML-2452-APA2-01 Indoor Dual Band Elbow Jointed Dipole: RP-SMA Male (Black)
ML-2452-APA2-02 Indoor Dual Band Elbow Jointed Dipole: RP-SMA Male (White)
ML-2452-PNA5-01R Dual Band Directional Panel: Connector Type N-Male
ML-2452-PNA7-01R Dual Band Panel: Connector Type N-Male
ML-2452-PTA2M3X3-1 AP-7131 MIMO Facade: 1 IN, RPSMA
ML-2452-PTA3M3-036 Ceiling Mount, Dual Band, MIMO Patch: RPSMA
ML-2452-HPA5-036 Dipole, RP-SMA-Male
ML-2452-PNL9M3-036 MIMO Dual Band Polarized Panel, RP-SMA Male
ML-2452-APAG2A1-01 Dipole, RP-SMA Male (Black) ML-2452-APAG2A1-02 Dipole, RP-SMA Male (White)
ML-2452-HPAG4A6-01 Outdoor Dipole Omni N-Male
ML-2452-HPAG5A8-01 Outdoor Dipole Omni N-Male
ML-2452-PTA6X6-036 Indoor dual-band MIMO Omni Array, RP-SMA Male
ML-2452-HPA6X6-036 802.11ABG 6-Port Omni Dipole Array, Type N Male x6
ML-2452-PTA2M2-036 802.11ABG 2-Port Patch Array, RP-SMA Male
ML-2452-PTA6M6-036 Six-Port Omnidirectional Panel, RP-SMA Male
ML-2452-PTA6M6-1 Six-Port Facade Antenna, RP-SMA Male
ML-2452-HPA6M6-072 11ABGN, 6P DB Omni, 2.0/4.8 dBi, LP, CBL 72, RP -SMA-M
ML-2452-VMM3M3-036 11ABGN, 3-Port Omni Array, RP-SMA Male x 3
AP6562 Internal 802.11ABGN, Multi-Element x 2
AP8222 Internal 802.11ABGN, 6 x PIFA, -1.8 dBi, LP, U.FI
AP-7522 and AP-7532 Dual-Band Monopole (2.4/5 Ghz)
ML-2452-PNL3M3-1 11ABGN, 3-Port Polarized Panel, 9.7/9.2 dBi, DP, Fixed N-Type Female
ML-2452-HPA6-01, 11ABGN, Dipole, N-Type Male
AP7502 Internal 802.11ABGNac, Dipole Omni x4
ML-2452-PNL6M3-N36 , 11ABGN, 120° Sector, 3-Port, 6/6 dBi, LP, CBL 36, N-Type-M
ML-2452-SEC6M3-N36 , 11ABGN, 3-Port, Multi-Pol, Dir Panel, 6.5/5.0 dBi, LP, CBL 36, N-Type-M
ML-2452-VMM5M3-N72, 11ABGN, 3-Port Dual-Band, Vertical Polarization Omni Array
ML-2452-PNL9M3-N36, 11ABGN, 3-Port Dual-Band, Dual Polarization Dir Panel2 V-Pol and 1 H-Pol ports
AP7562 Facade Antenna
AP8432 Dual-Band Internal Antenna (2.4/5 GHz)
AP8533i Dual-Band Internal Antenna (2.4/5 GHz)
AP7602 Dual-Band Internal Antenna (2.4/5 GHz)

AP7612 Dual-Band Internal Antenna (2.4/5 GHz)
AP-7632i Dual-Band Internal Antenna (2.4/5 GHz)
AP7662i Dual-Band Internal Antenna (2.4/4.9/5 GHz)
AP7622 Dual-Band Internal Antenna (2.4/5 GHz)
ML-2452-PTA4M4-036, 4-Port, Dual-Band, Ceiling Mount, Circular Omni Array (4 V-Pol ports)
ML-2452-SEC6M4-036, Dual Polarized, Dual Band Wide Beam Directional Antenna, 32 Inch Cable, RPSMA-Male Connector
ML-2452-HPA6M4-S36, Dual Band, Four Input Omni, 36 Inch Cable, RPSMA Connectors
ML-2452-PNL6M4-N36 Dual Polarized, Dual Band Narrow Beam Directional Antenna, with 36 Inch Cable and N-Male Connector
ML-2452-SEC6M4-N30 Dual Band Sector Antenna, with 30 Inch Cable and N Male Connectors
ML-2452-SEC6M4-N36 Dual Polarized Dual Band Wide Beam Directional Antenna, with 32 Inch Cable and N-Male Connector

Several 2.4GHz - 5.2GHz Dual Band antennas are supported to suit your unique deployment. Check the Support site periodically, as newly supported 2.4GHz - 5.2GHz Dual Band antennas are added to this document as they are released.

ML-2452-APA2-01 Indoor Dual Band Elbow Jointed Dipole: RP-SMA Male (Black) ML-2452-APA2-02 Indoor Dual Band Elbow Jointed Dipole: RP-SMA Male (White)

Type	Dipole
Frequency	2400-2500/5150-5850 MHz
Max Gain (dBi)	3.2 / 4.9
Polarization	Linear, Vertical
Azimuth	3dB Beamwidth: 360°/360°
Elevation	3dB Beamwidth: 45°/30°
Cable Length (in.)	N/A
Cable Type	N/A
Connector Type	RP-SMA Male
Weight	0.7 oz
Plenum Antenna	No
Plenum Cable	N/A
Outdoor Rated	No
Storage Temp Range (C)	-10 / +70
Operation Temp Range (C)	-10 / +60

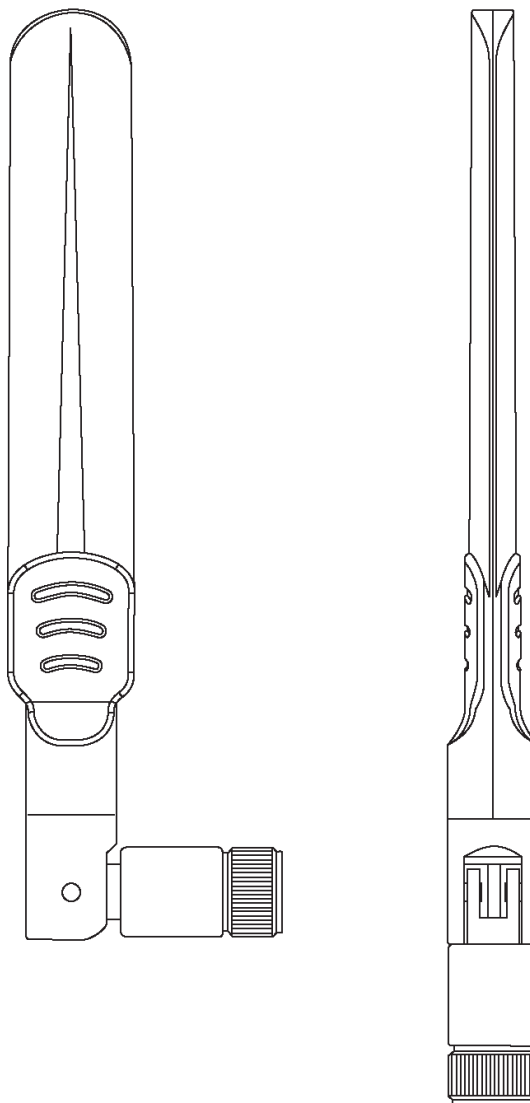

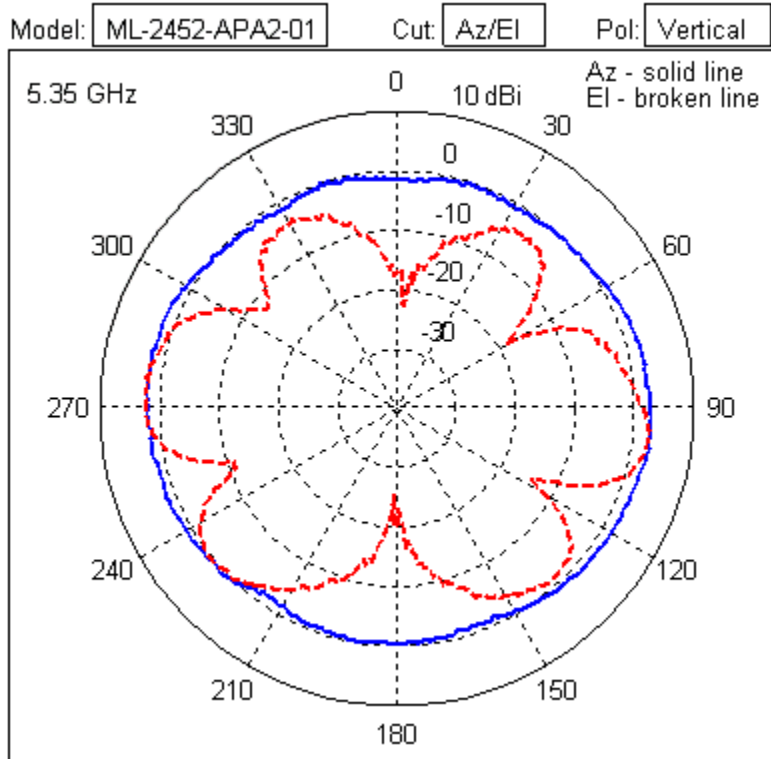
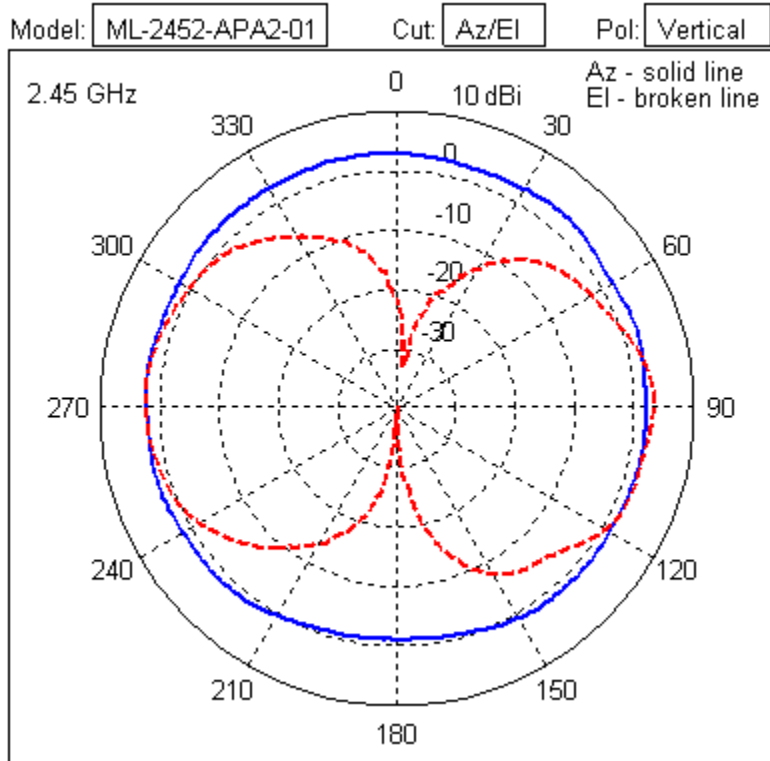

ML-2452-PNA5-01R Dual Band Directional Panel: Connector Type N-Male

Type	Panel
Frequency	2400-2500/4900-5900 MHz
Max Gain (dBi)	5.5/6.0
Polarization	Linear, Vertical
Azimuth	3dB Beamwidth: 120°/ 120°
Elevation	3dB Beamwidth: 60°/ 60°
Max UNII-1 Elevation Gain (dBi)	5.2
Cable Length (in.)	12
Cable Type	RG-58 Ultralink
Connector Type	Type N Male
Weight	0.2 lb
Plenum Antenna	No
Plenum Cable	Yes
Outdoor Rated	Yes
Storage Temp Range (C)	-30 / +70
Operation Temp Range (C)	-30 / +70

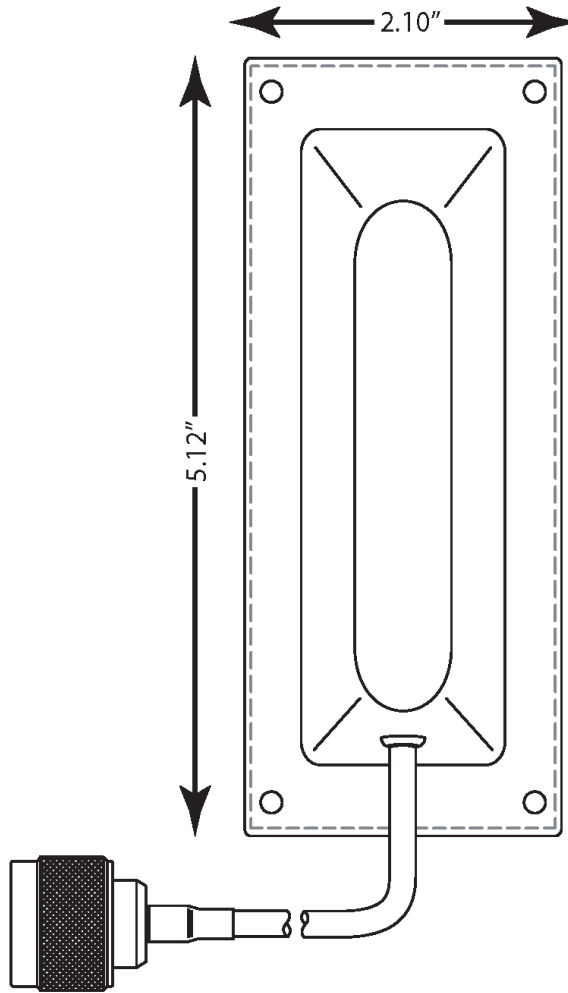

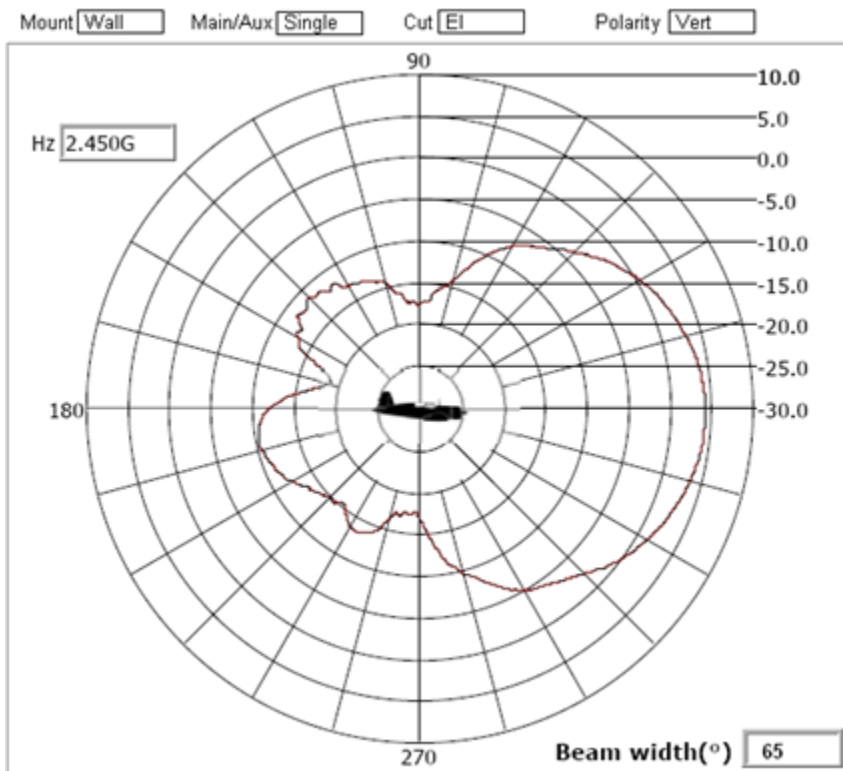

Elevation Pattern

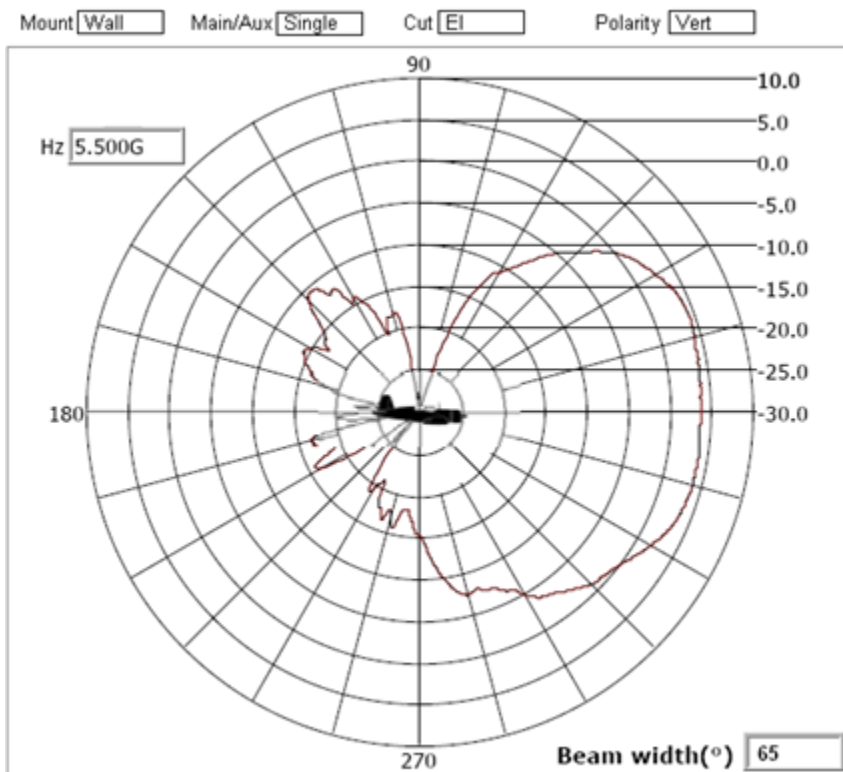

Elevation Pattern

ML-2452-PNA7-01R Dual Band Panel: Connector Type N-Male

Type	Panel
Frequency	2400-2500/4900-5900 MHz
Max Gain (dBi)	8.0/12.0
Polarization	Linear, Vertical
Azimuth	3dB Beamwidth: 68°/ 52°
Elevation	3dB Beamwidth: 66°/ 60°
Cable Length (in.)	12
Cable Type	RG-58 Ultralink
Connector Type	Type N Male
Weight	0.5 lb
Plenum Antenna	No
Plenum Cable	Yes
Outdoor Rated	Yes
Storage Temp Range (C)	-40 / +85
Operation Temp Range (C)	-30 / +70

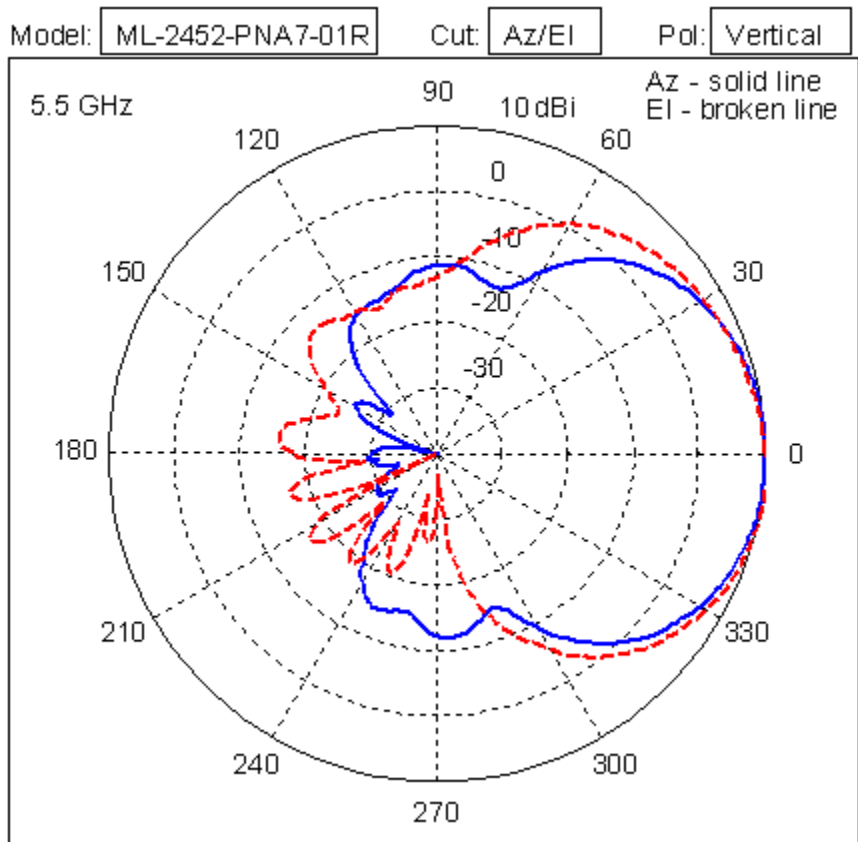
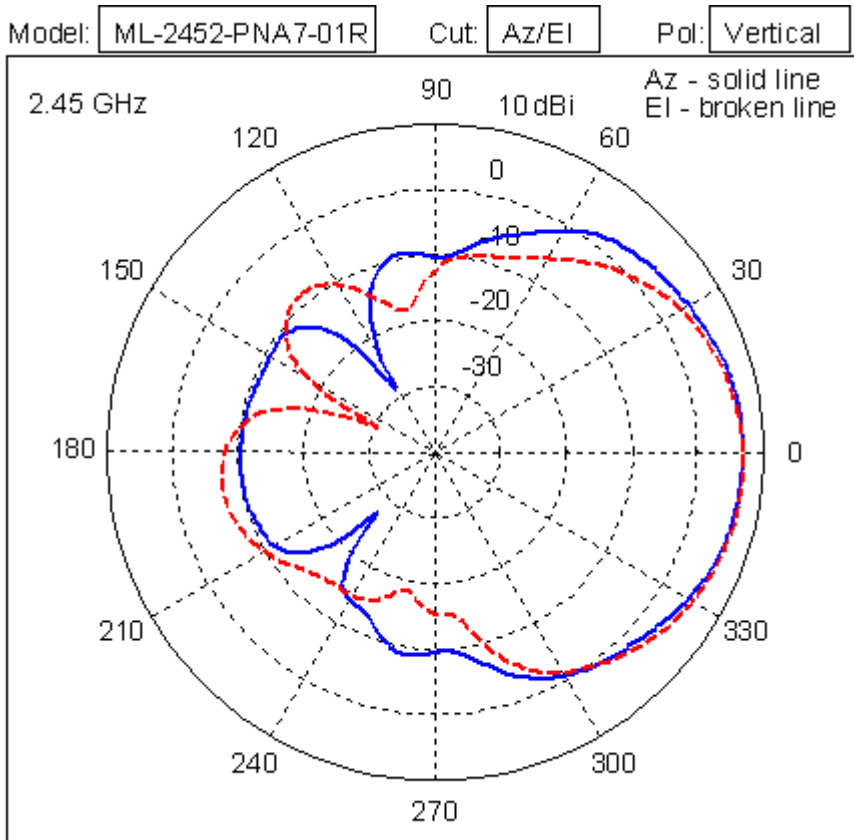

ML-2452-PTA2M3X3-1 AP-7131 MIMO Facade: 1 IN, RPSMA

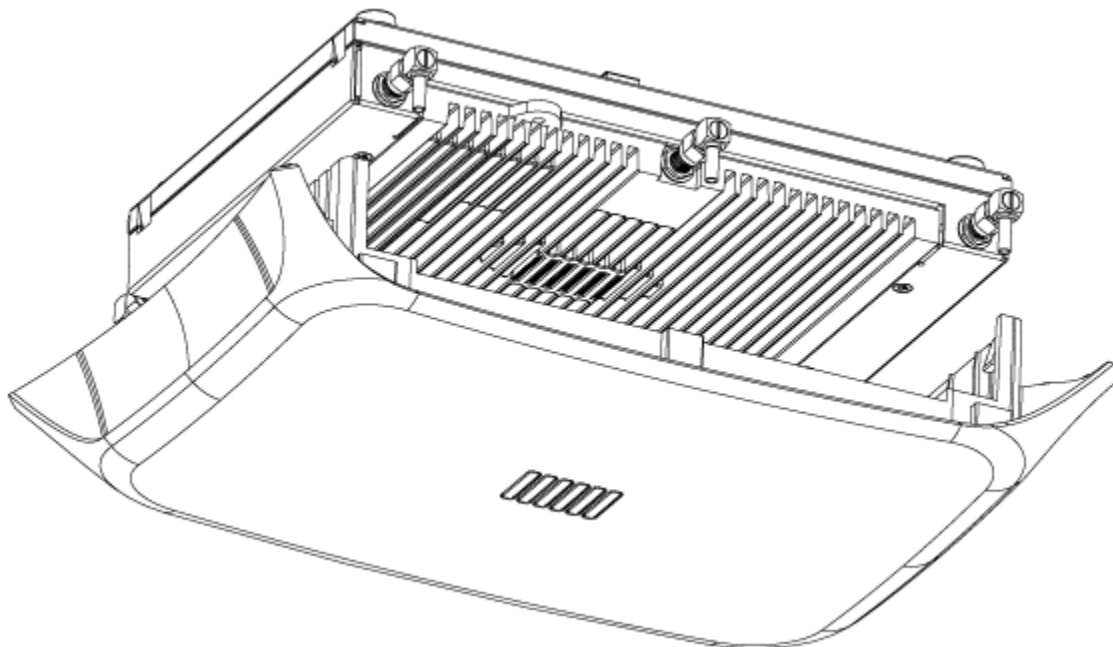

Type	Patch x 6 in snap-on facade
Frequency	2400-2500/4900-5990 MHz
MAx Gain (dBi)	3.0/5.0
Polarization	Linear, Vertical
Azimuth	3dB Beamwidth: 360°
Elevation	3dB Beamwidth: 90° (southern hemisphere pattern)
Cable Length (in.)	Integrated into snap-on facade
Cable Type	1.20 mm coax
Connector Type	RP-SMA Male
Antenna Plenum Rated	No
Cable Plenum Rated	No
Outdoor Rated	No
Weight	0.79 lb



Note

ML-2452-PTA2M3x3-1 was formally released as part number ML-2452-APA2-FAC.

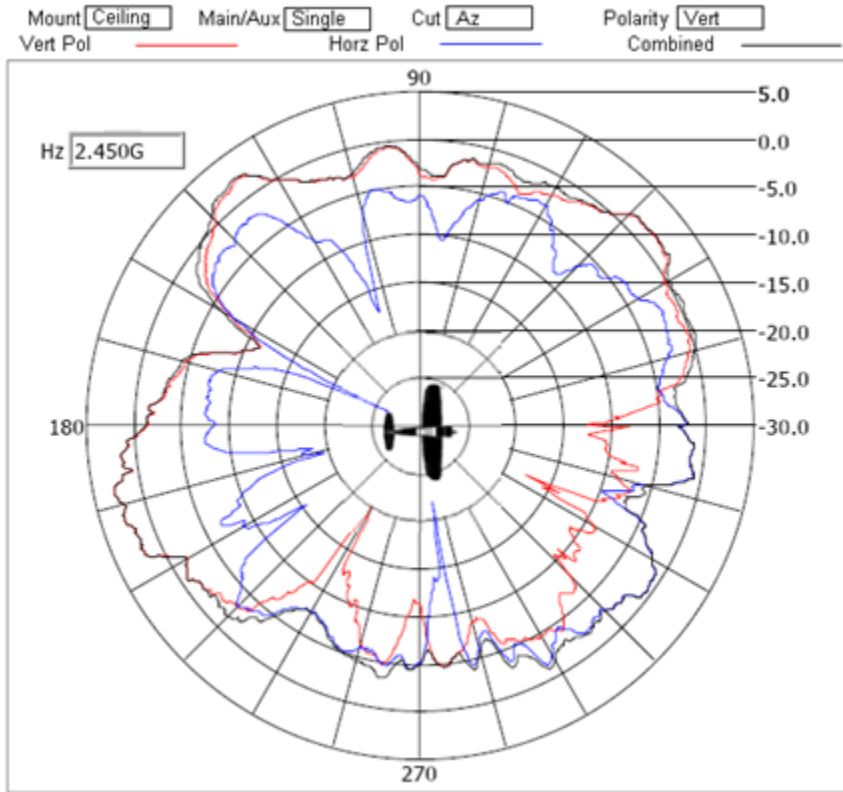

Azimuth Pattern

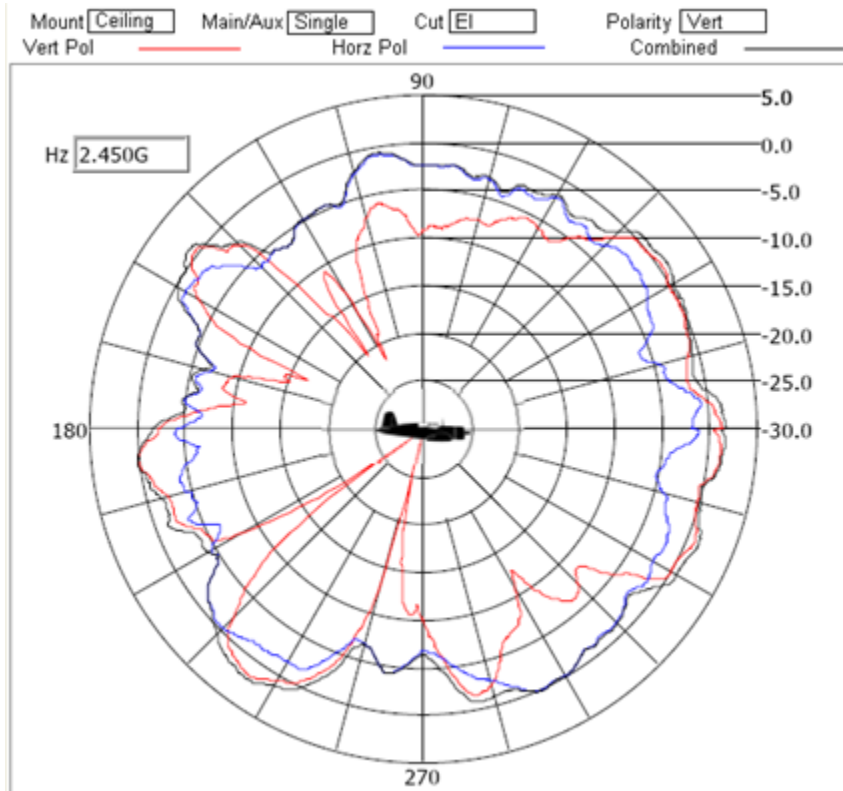

Elevation Pattern

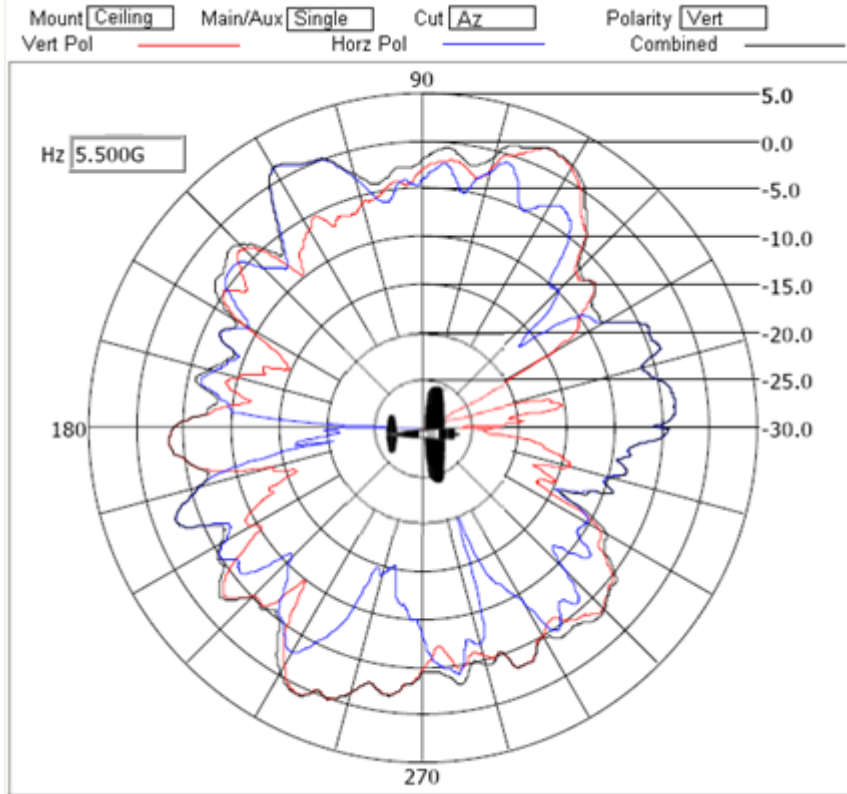

Azimuth Pattern

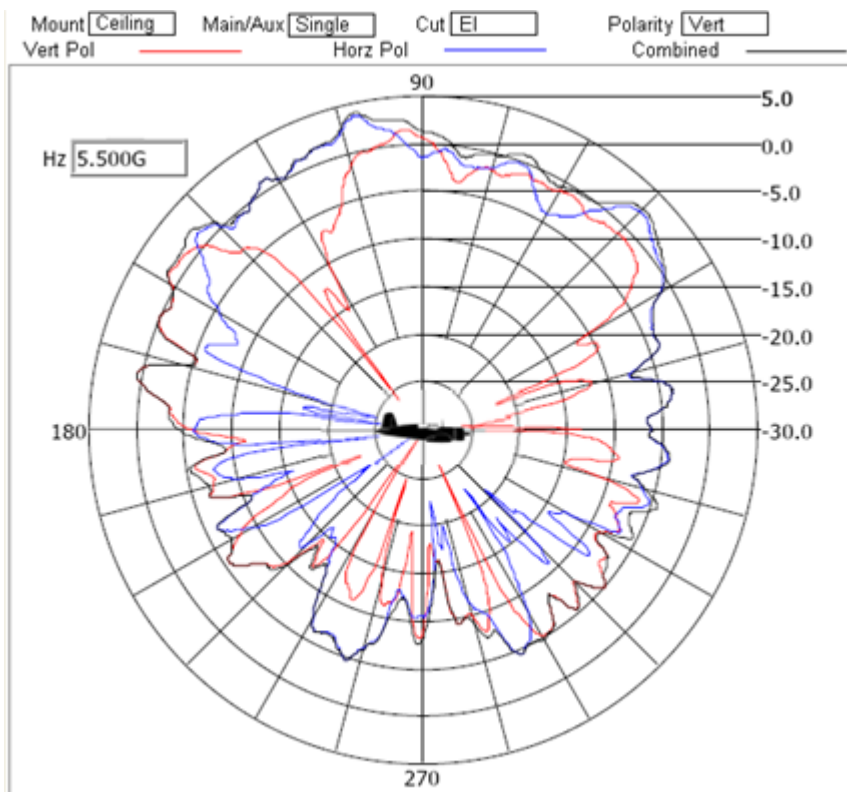

Elevation Pattern

ML-2452-PTA3M3-036 Ceiling Mount, Dual Band, MIMO Patch: RPSMA

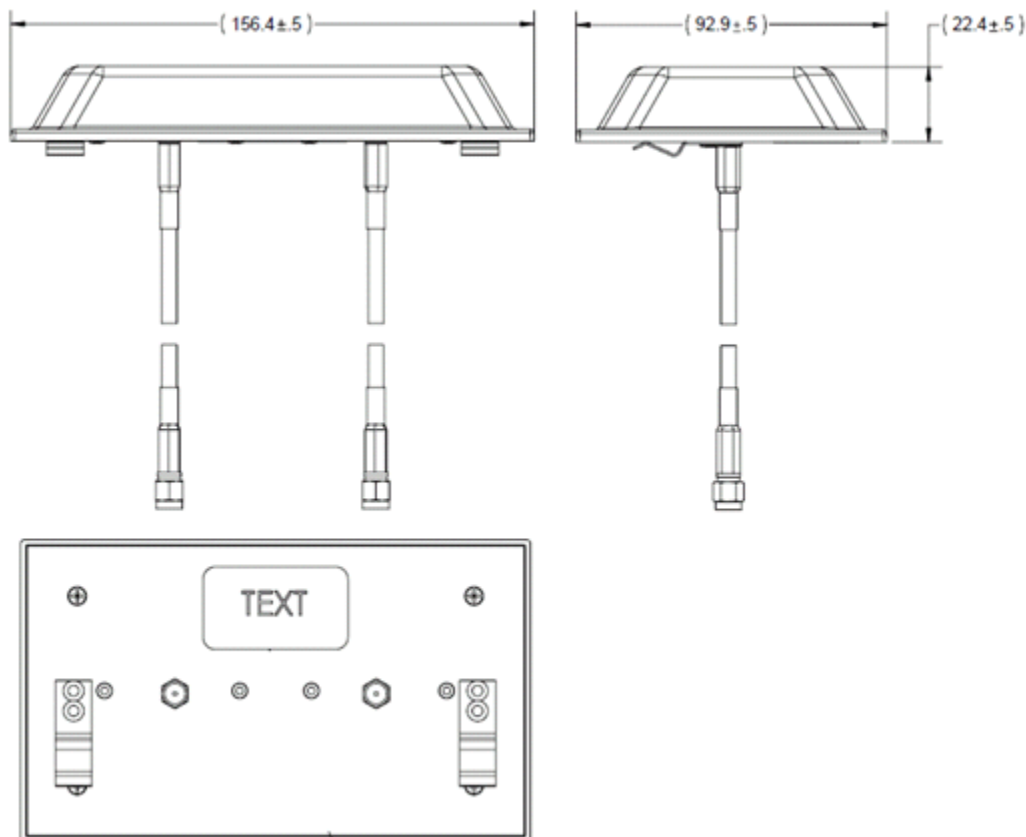

Type	Patch x 3
Frequency	2400-2500/4900-5990 MHz
Max Gain (dBi)	5.0 /4.0
Polarization	Linear, Vertical
Azimuth	3dB Beamwidth: 360° / 360°
Elevation	3dB Beamwidth: 60° / 60° (southern hemisphere pattern)
Cable Length (in.)	36
Cable Type	RG-58
Connector Type	RP-SMA Male
Antenna Plenum Rated	No
Cable Plenum Rated	Yes
Outdoor Rated	No
Weight	0.75 lb
Storage Temp Range (C)	-40 / +85
Operation Temp Range (C)	-35/ +70

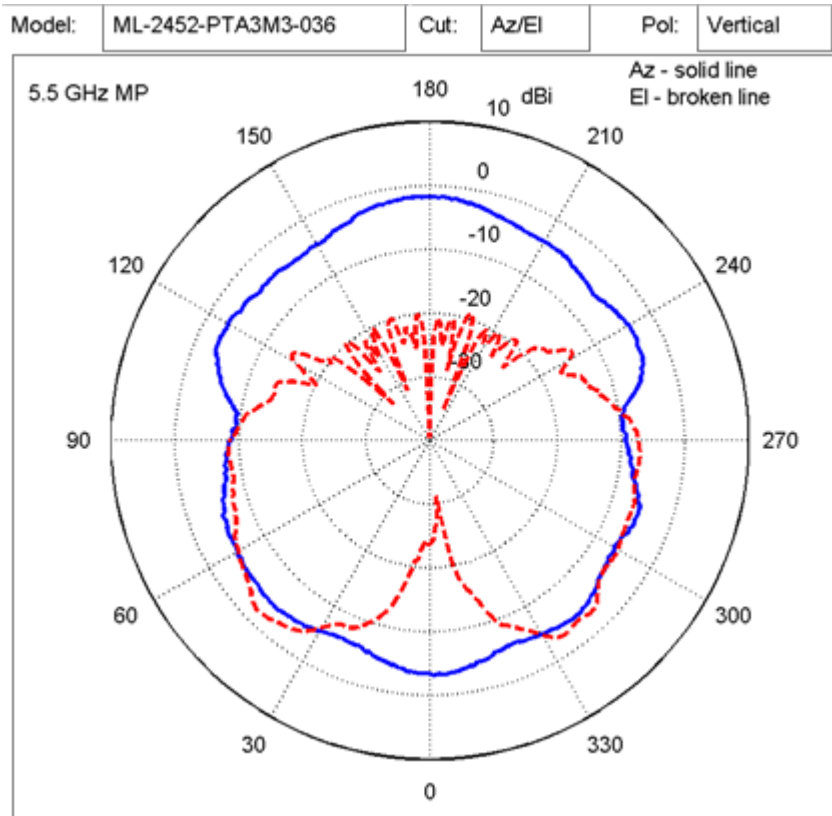
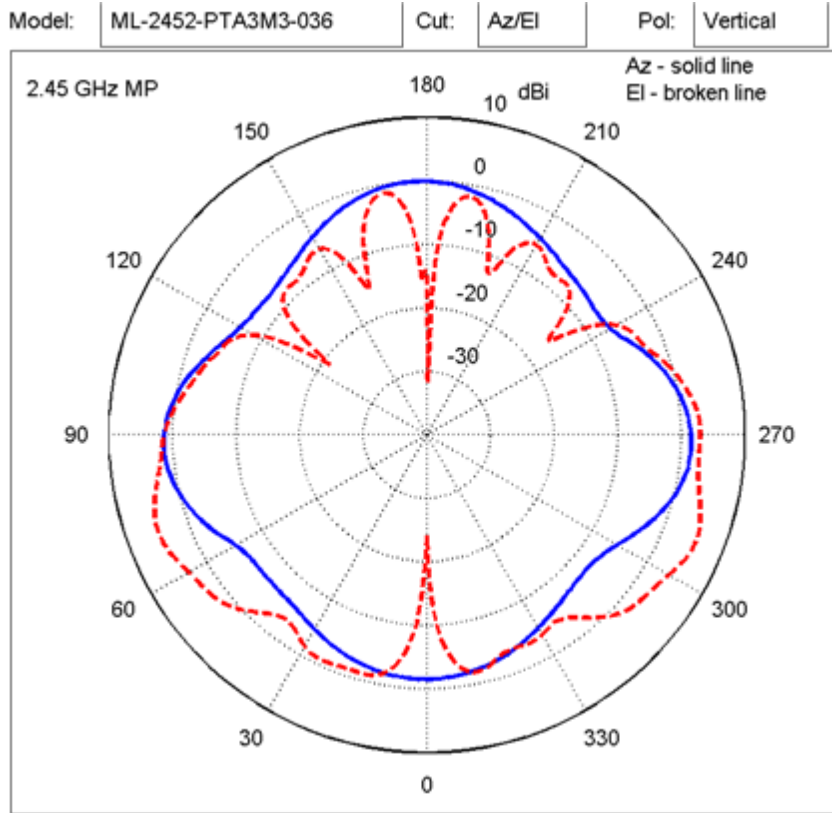

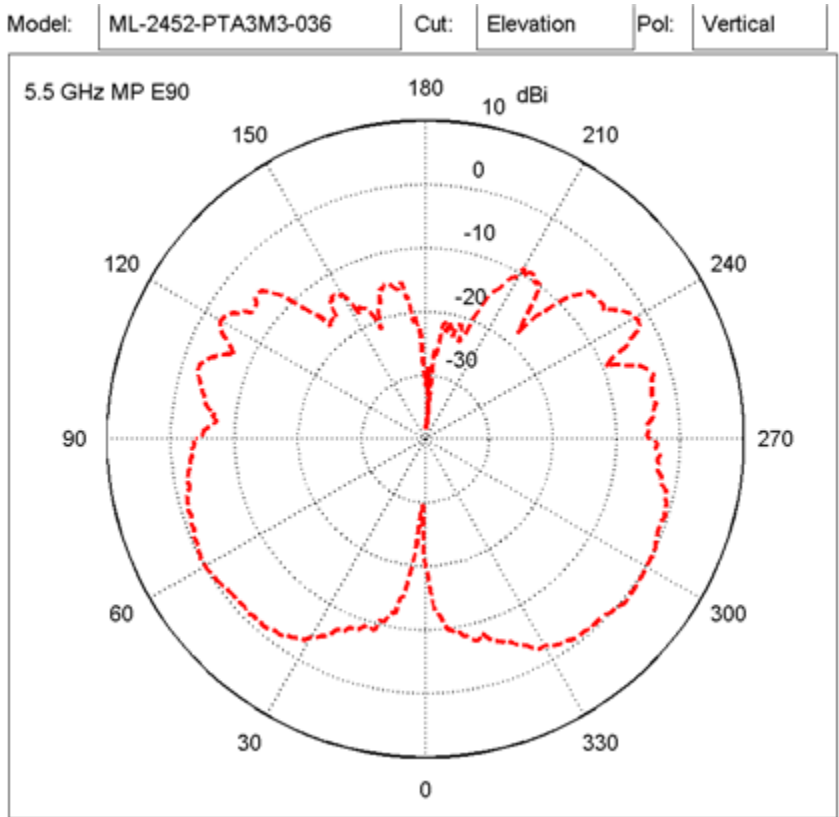
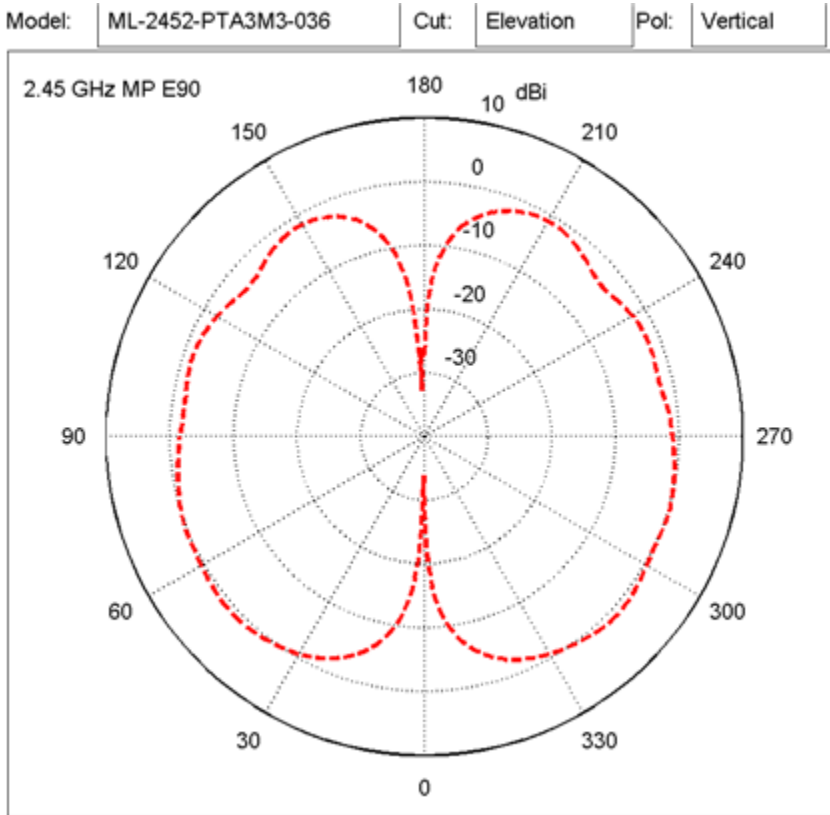

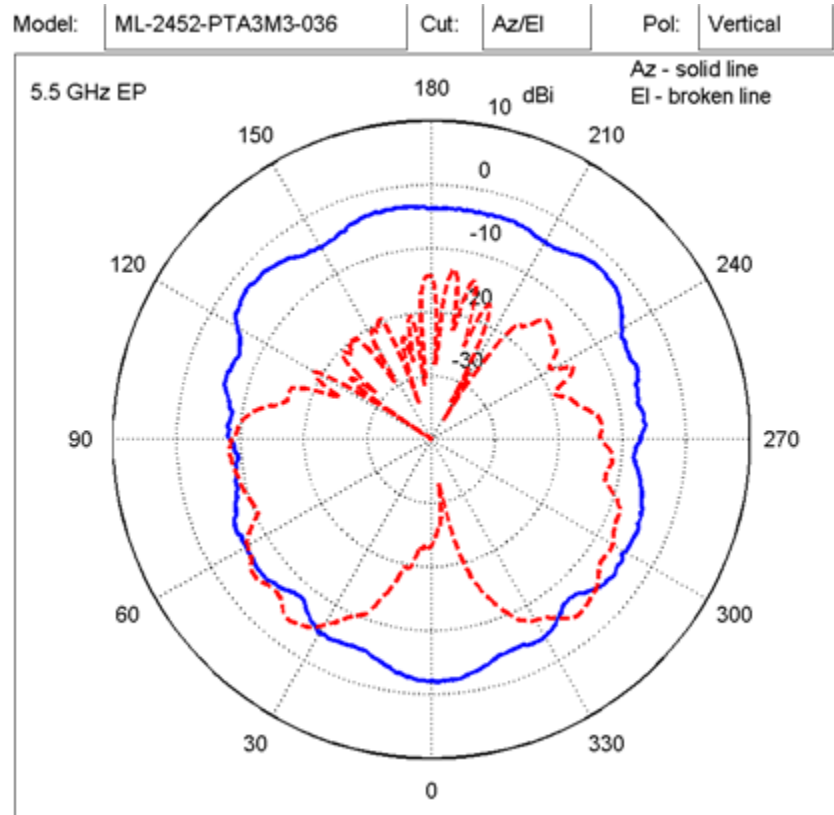
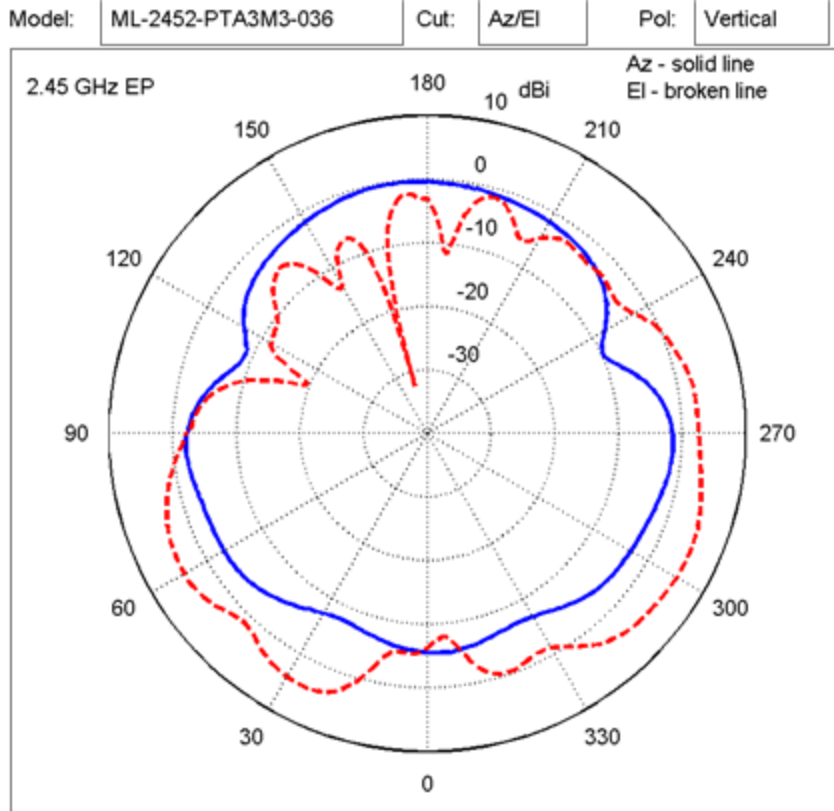

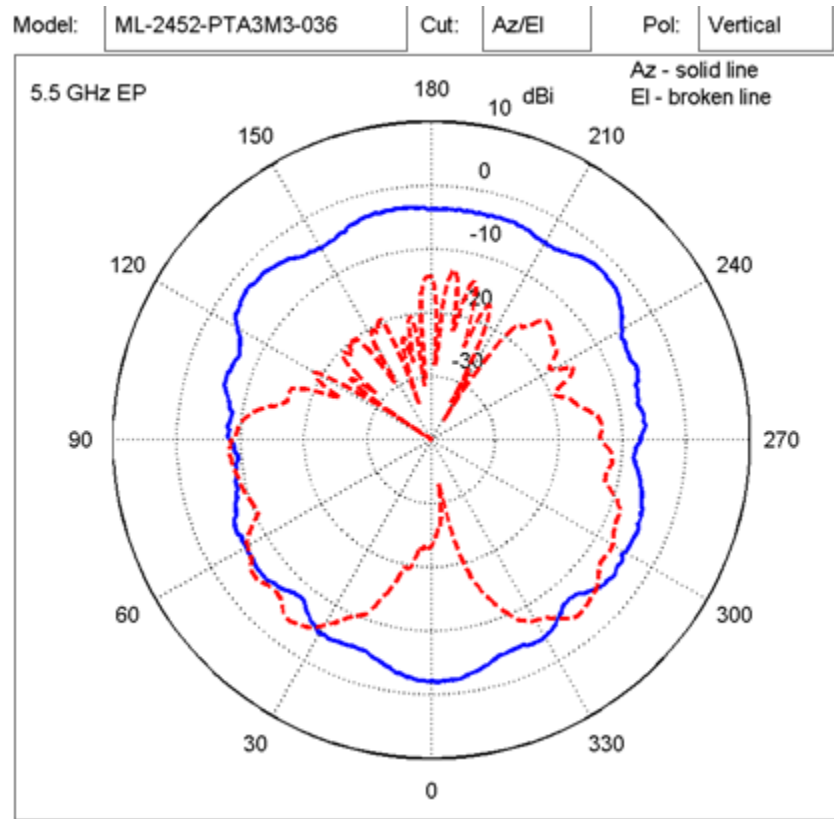
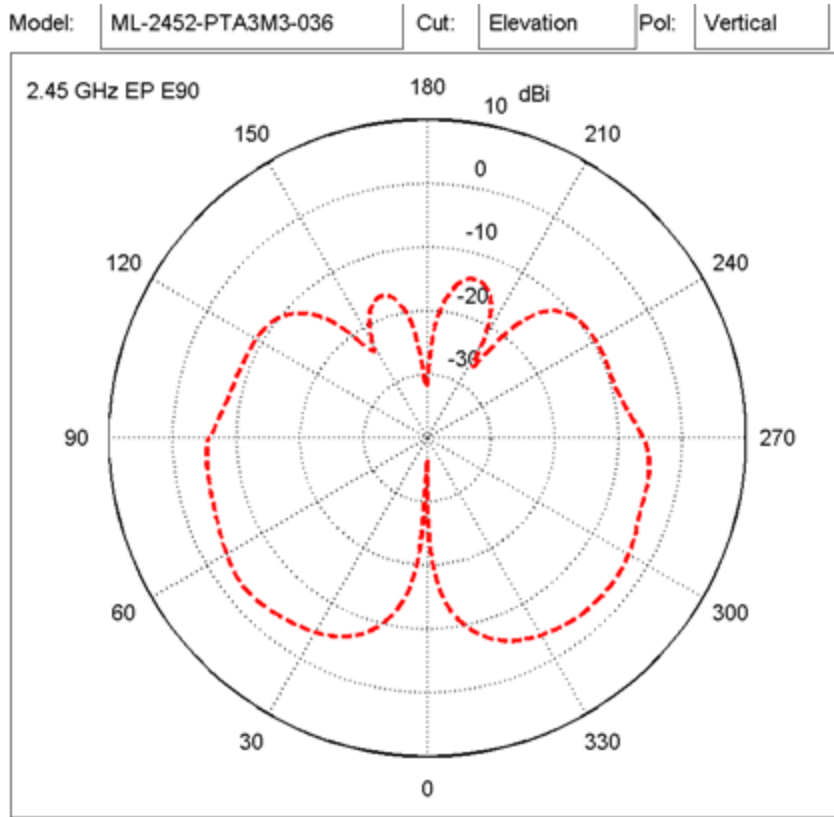

ML-2452-HPA5-036 Dipole, RP-SMA-Male

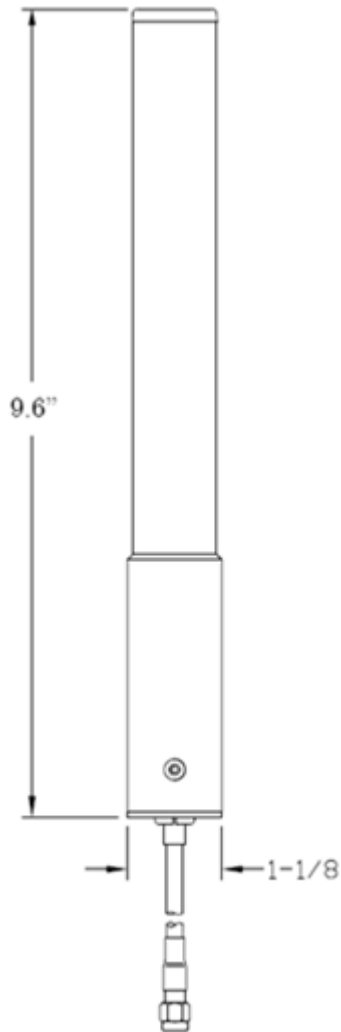

Type	Dipole
Frequency	2450-2500/5150-5875 MHz
Max Gain (dBi)	3.0 / 5.0
Polarization	Linear, Vertical
Azimuth	3dB Beamwidth: 360°/360°
Elevation	3dB Beamwidth: 50°/45°
Max UNII-1 Elevation Gain (dBi)	-2.56
Cable Length (in.)	36
Cable Type	RG-58 Plenum
Connector Type	RP-SMA Male
Antenna Plenum Rated	N/A
Cable Plenum Rated	Yes

Outdoor Rated	Yes
Weight	0.3 lbs
Storage Temp Range (C)	-40 / +85
Operation Temp Range (C)	-30 / +70

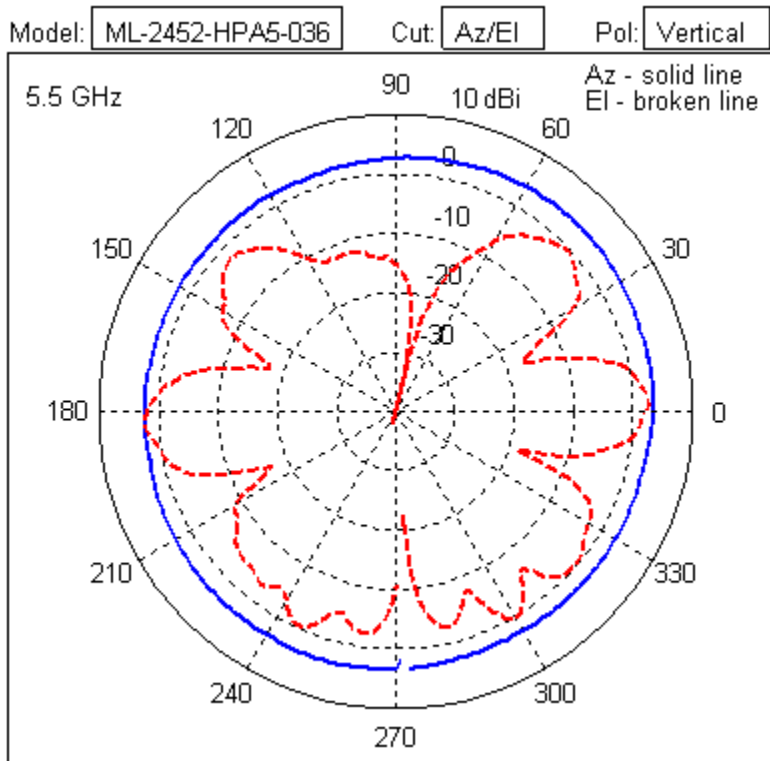
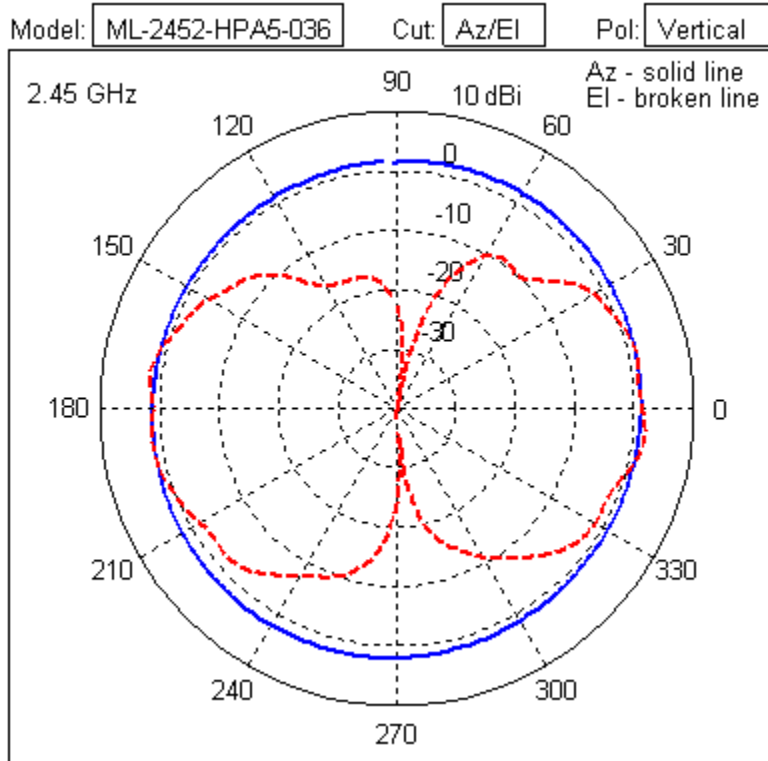

ML-2452-PNL9M3-036 MIMO Dual Band Polarized Panel, RP-SMA Male

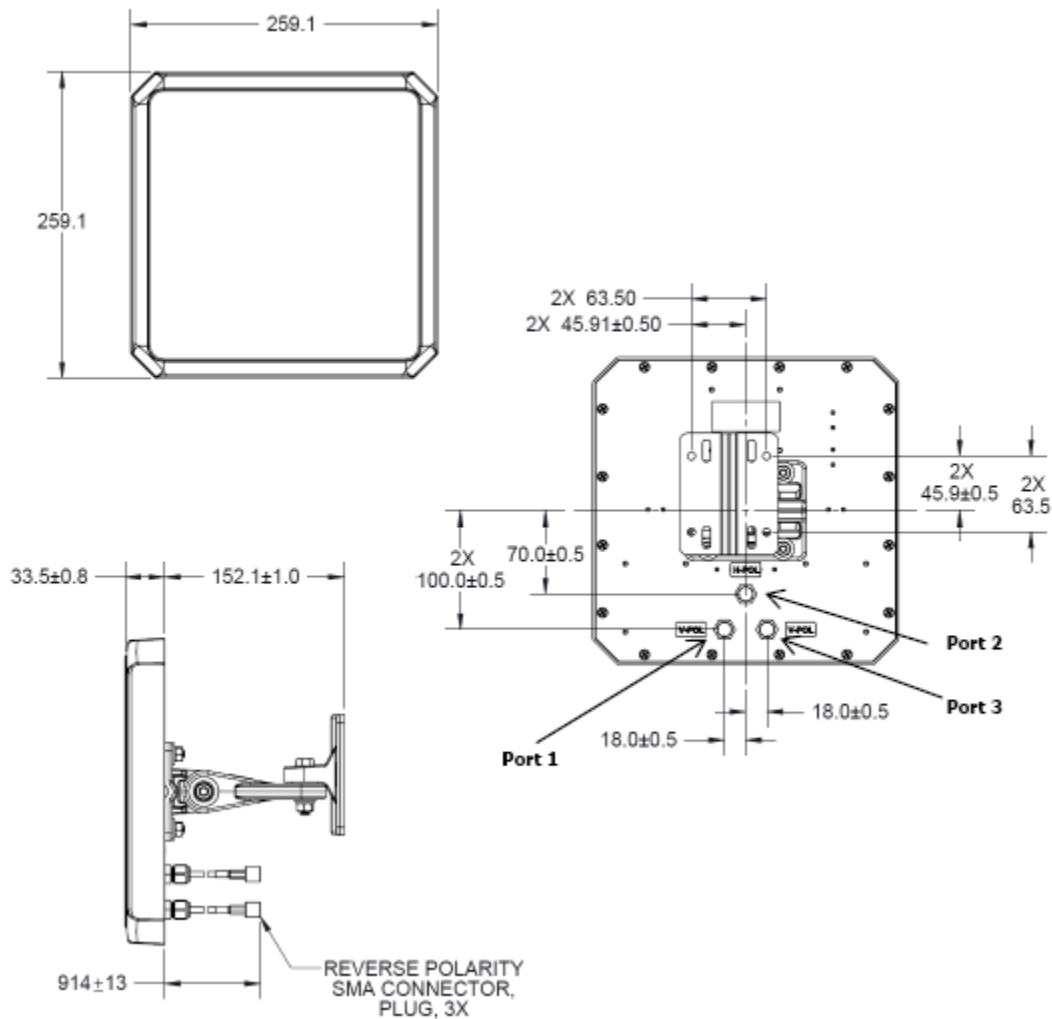

Note

The dimensions for the ML-2452-PNL9M3-036 model antenna are displayed in millimeters (mm) within the illustration above.

Type	Polarized Panel
Frequency	2400-2500/4900-5875 MHz
Max Gain (dBi)	11.0 / 10.7
Polarization	Linear, 2x Vertical, 1x Horizontal
Azimuth	3dB Beamwidth: 75° / 55°
Elevation	3dB Beamwidth: 70° / 60°
Max UNII-1 Elevation Gain (dBi)	7.5

Cable Length (in.)	36
Cable Type	RG-58
Connector Type	RP-SMA Male
Antenna Plenum Rated	N/A
Cable Plenum Rated	Yes
Outdoor Rated	Yes
Weight	1.81 lbs
Storage Temp Range (C)	-40 / +70
Operation Temp Range (C)	-30 / +65

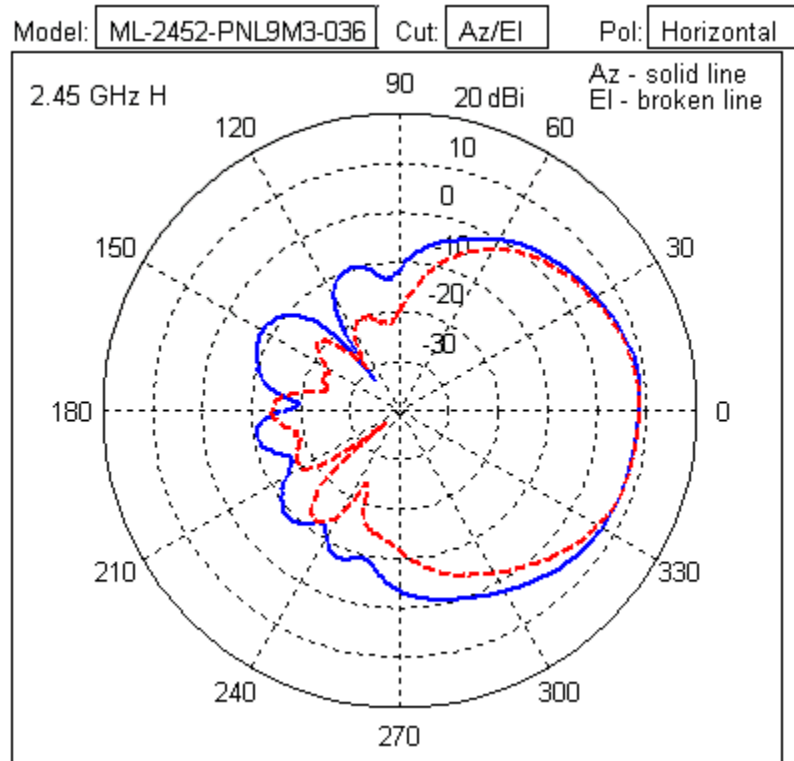
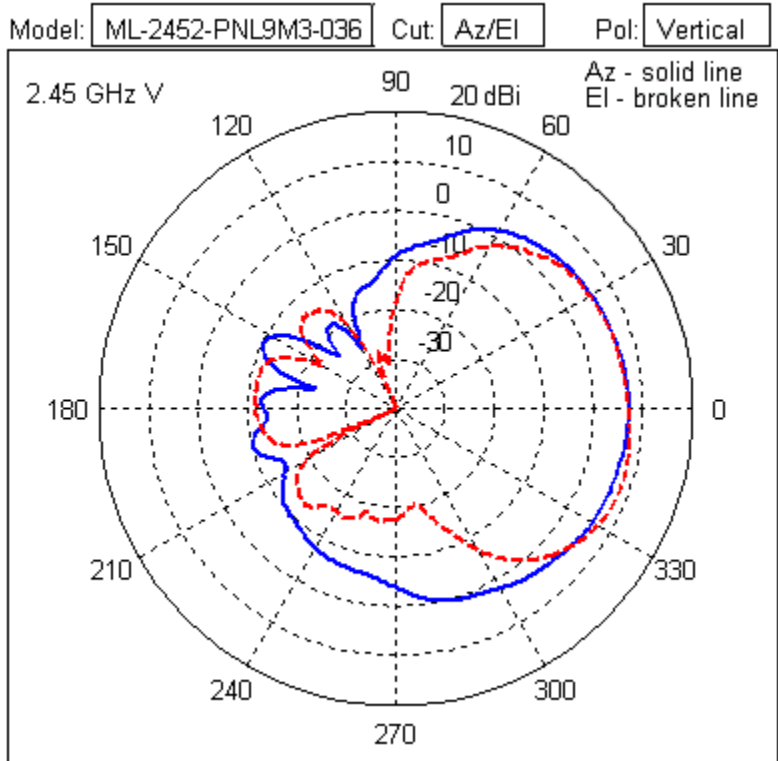

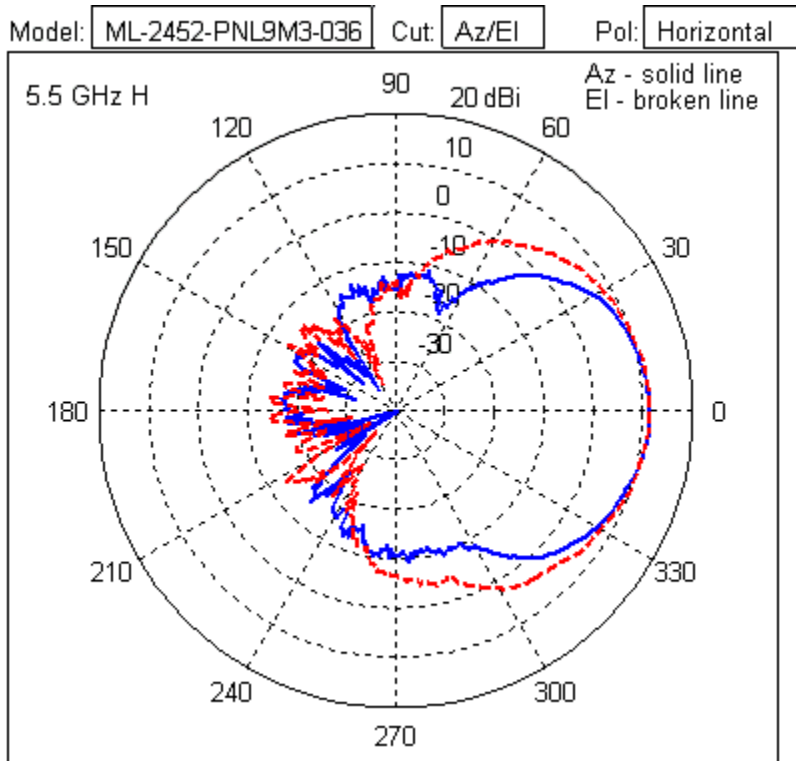
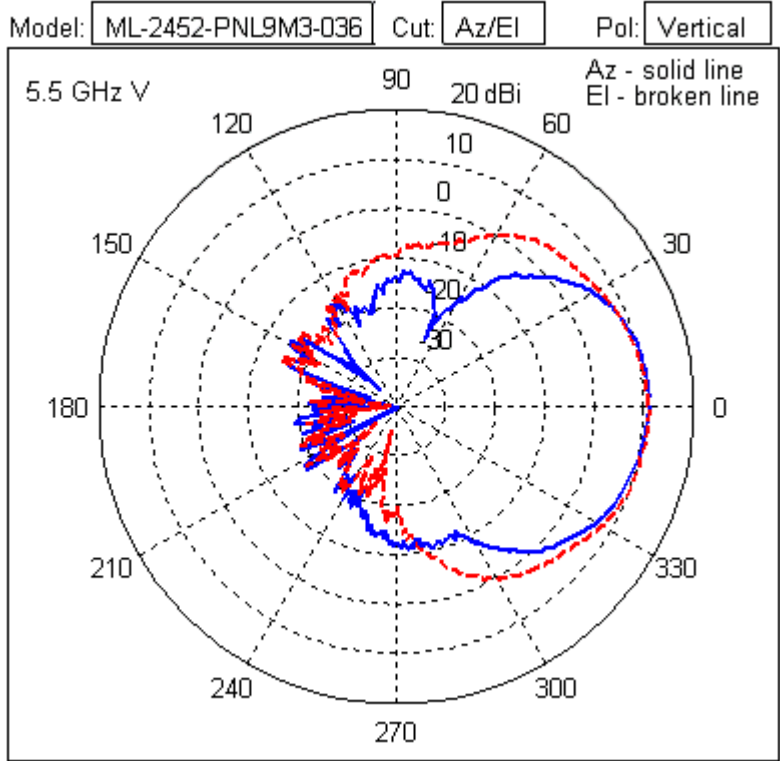

ML-2452-APAG2A1-01 Dipole, RP-SMA Male (Black) ML-2452-APAG2A1-02 Dipole, RP-SMA Male (White)

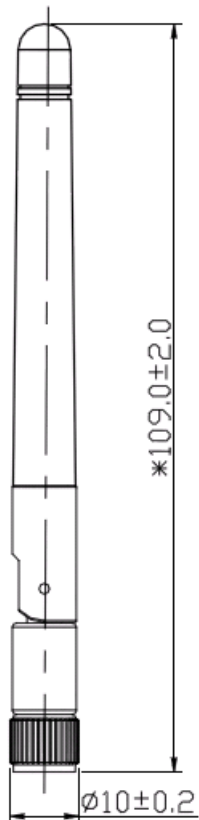

Type	Dipole
Frequency	2400-2500/4900-5900 MHz
Max Gain (dBi)	2.7 / 2.0
Polarization	Linear, Vertical
Azimuth	3 dB Beamwidth: 360° /360°
Elevation	3 dB Beamwidth: 60° /60°
Cable Length (in.)	N/A
Cable Type	N/A
Connector Type	RP-SMA Male
Antenna Plenum Rated	No
Cable Plenum Rated	No
Outdoor Rated	No
Weight	10 g
Storage Temp Range (C)	-40 / +80
Operation Temp Range (C)	-40 / +65

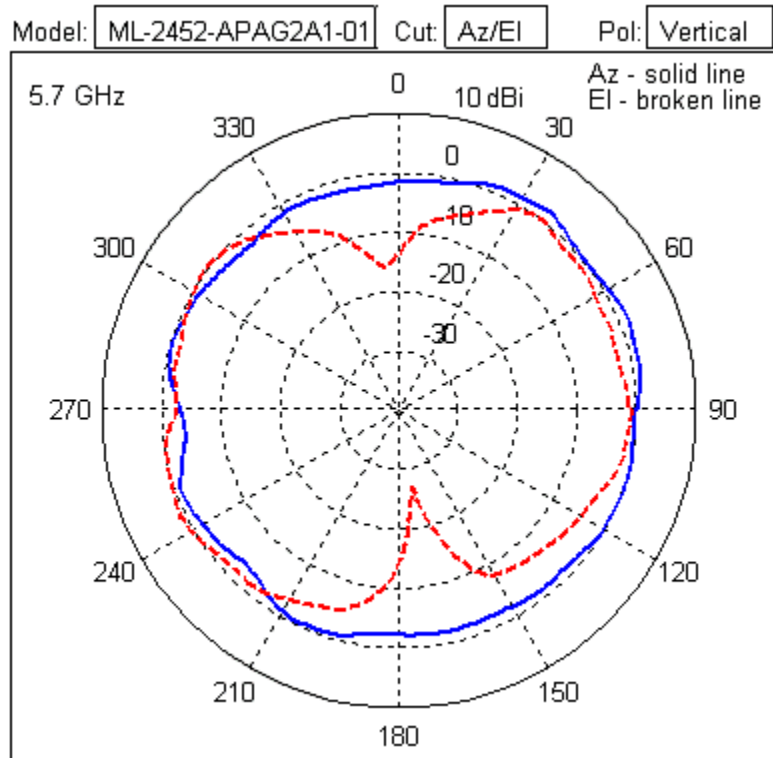
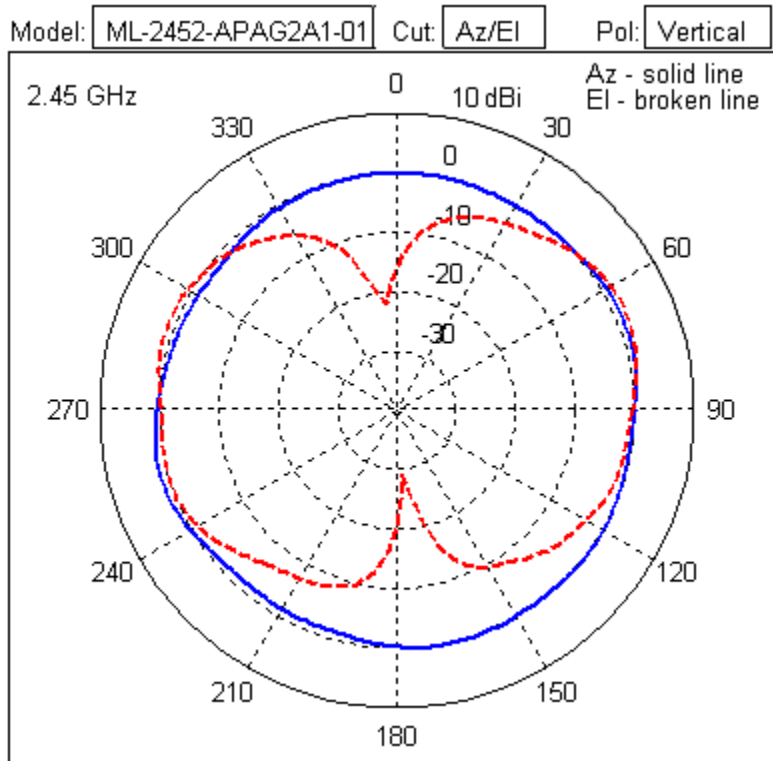

ML-2452-HPAG4A6-01 Outdoor Dipole Omni N-Male

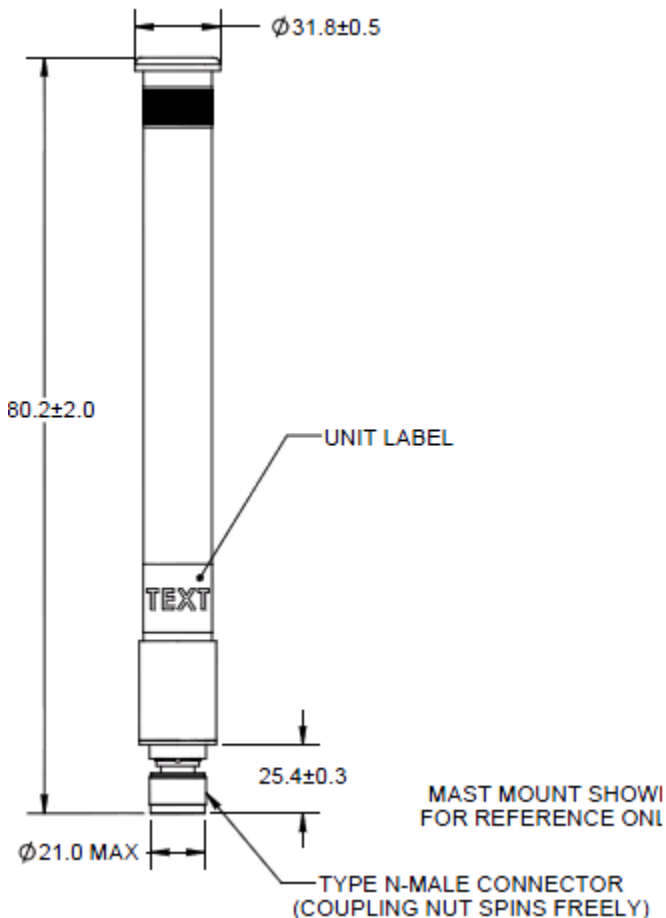

Type	Dual-band Dipole Omni
Frequency	2400-2500/5150-5875 MHz
Max Gain (dBi)	4.0 / 7.3
Elevation Gain (dBi)	5.7
Polarization	Linear, Vertical
Azimuth	3 dB Beamwidth: 360 degrees (2.4 GHz) 3 dB Beamwidth: 360 degrees (5 GHz)
Elevation	3 dB Beamwidth: 50 degrees (2.4 GHz) 3 dB Beamwidth: 18 degrees (5 GHz)
Cable Length (in.)	N/A
Cable Type	N/A
Connector Type	N-type Male
Antenna Plenum Rated	No
Cable Plenum Rated	N/A
Outdoor Rated	Yes

Weight	0.35 lbs
Storage Temp Range (C)	-40 / +85
Operation Temp Range (C)	-30 / +70

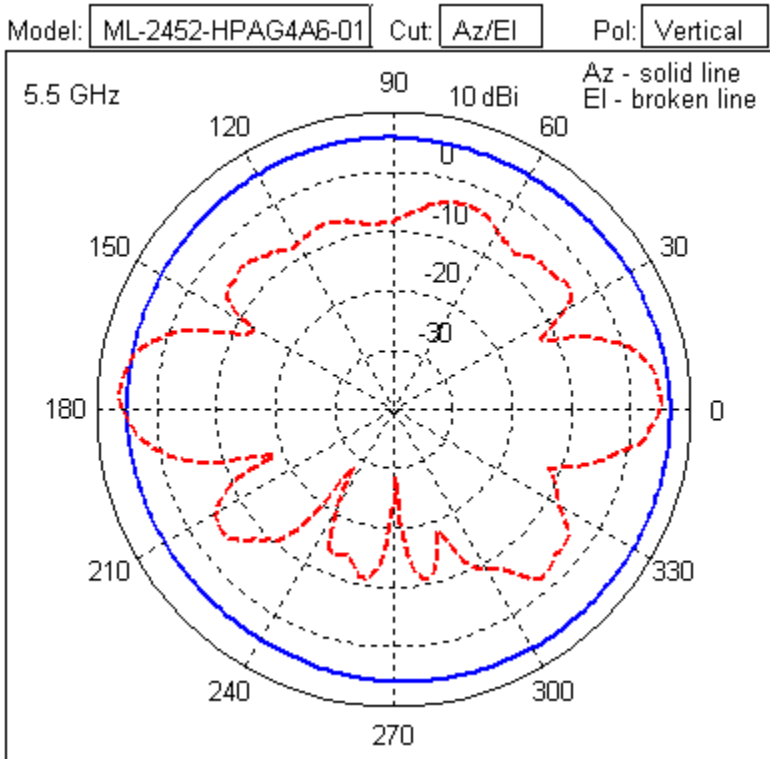
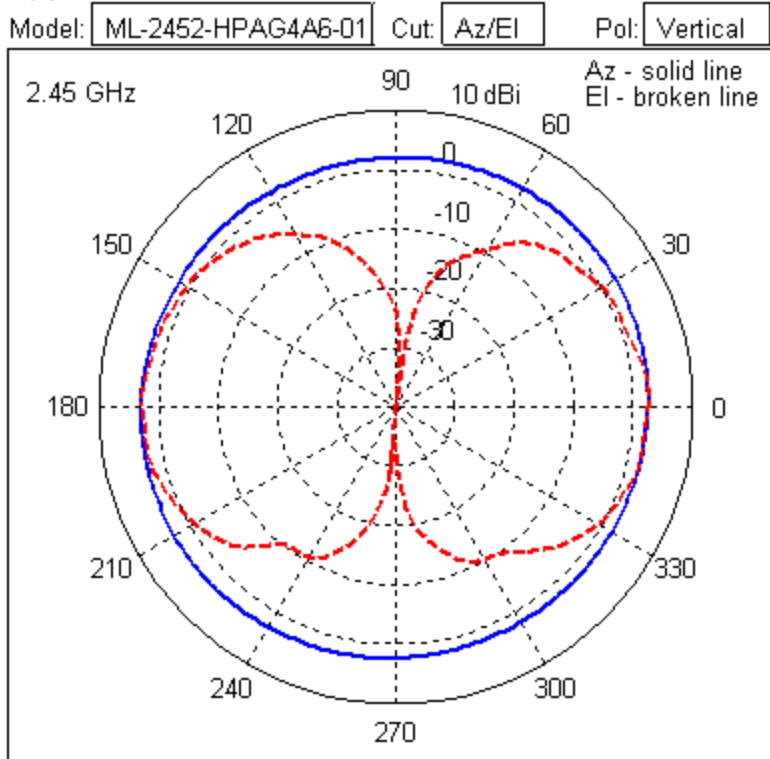

ML-2452-HPAG5A8-01 Outdoor Dipole Omni N-Male

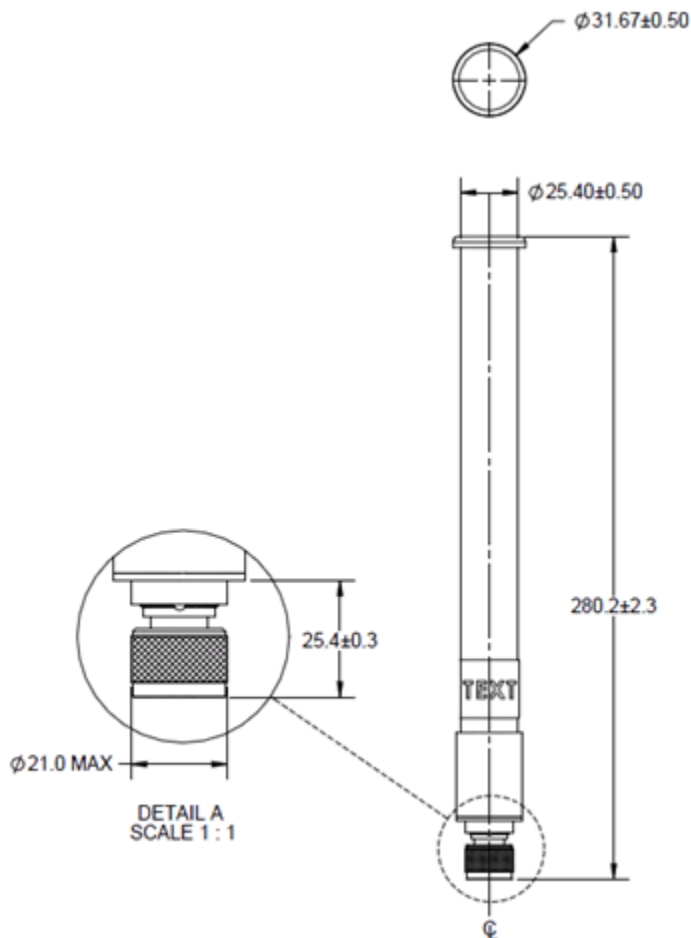

Type	Dual-band Dipole Omni
Frequency	2400-2500/5150-5875 MHz
Max Gain (dBi)	7.5/ 8.0
Polarization	Linear, Vertical
Azimuth	3 dB Beamwidth: 360 degrees (2.4 GHz) 3 dB Beamwidth: 360 degrees (5 GHz)
Elevation	3 dB Beamwidth: 28 degrees (2.4 GHz) 3 dB Beamwidth: 15 degrees (5 GHz)
Max UNII-1 Elevation Gain (dBi)	-9.7
Cable Length (in.)	N/A
Cable Type	N/A
Connector Type	N-type Male
Antenna Plenum Rated	No
Cable Plenum Rated	N/A
Outdoor Rated	Yes

Weight	0.33 lbs
Storage Temp Range (C)	-40 / +85
Operation Temp Range (C)	-30 / +70

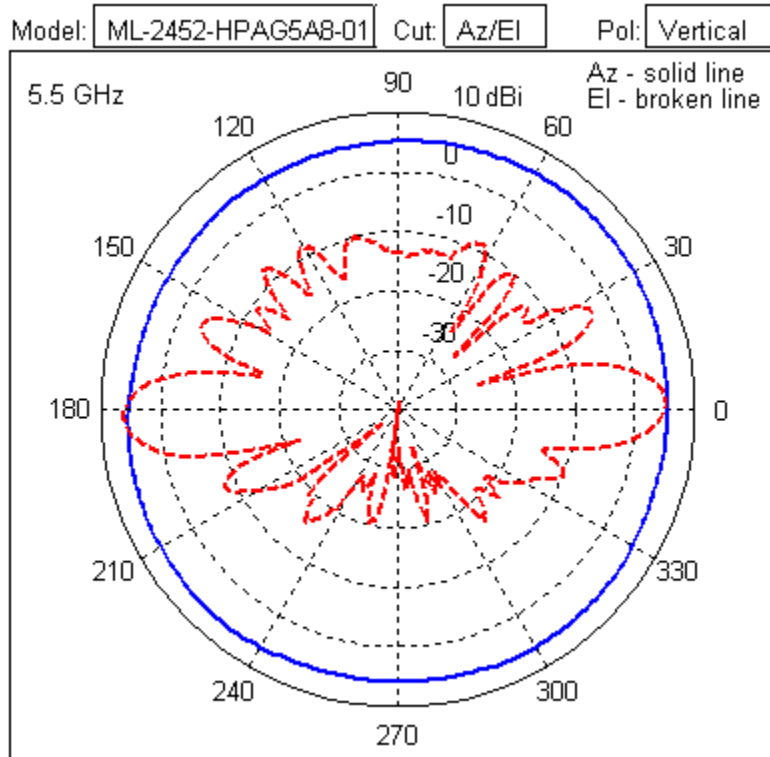
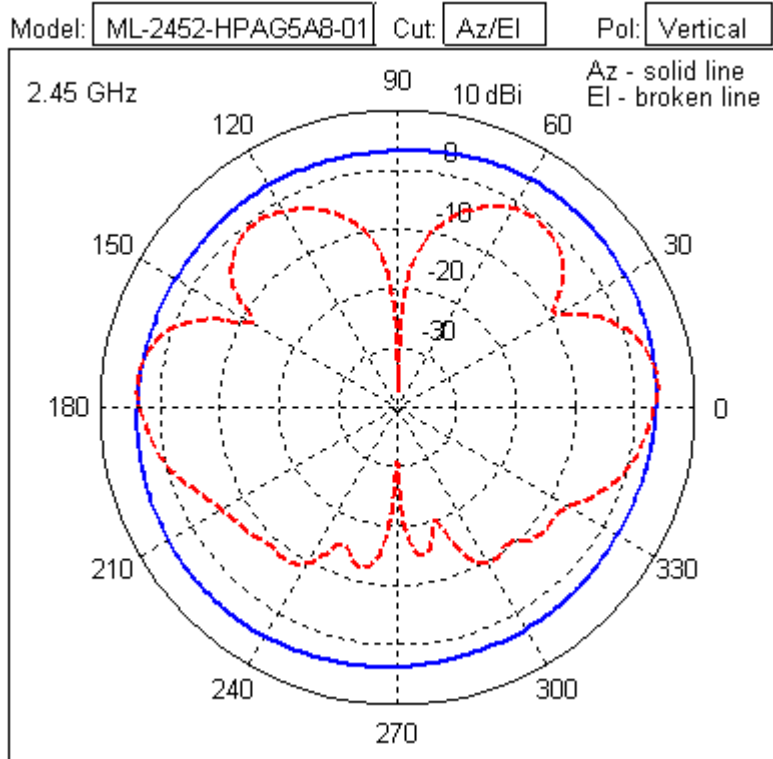

ML-2452-PTA6X6-036 Indoor dual-band MIMO Omni Array, RP-SMA Male

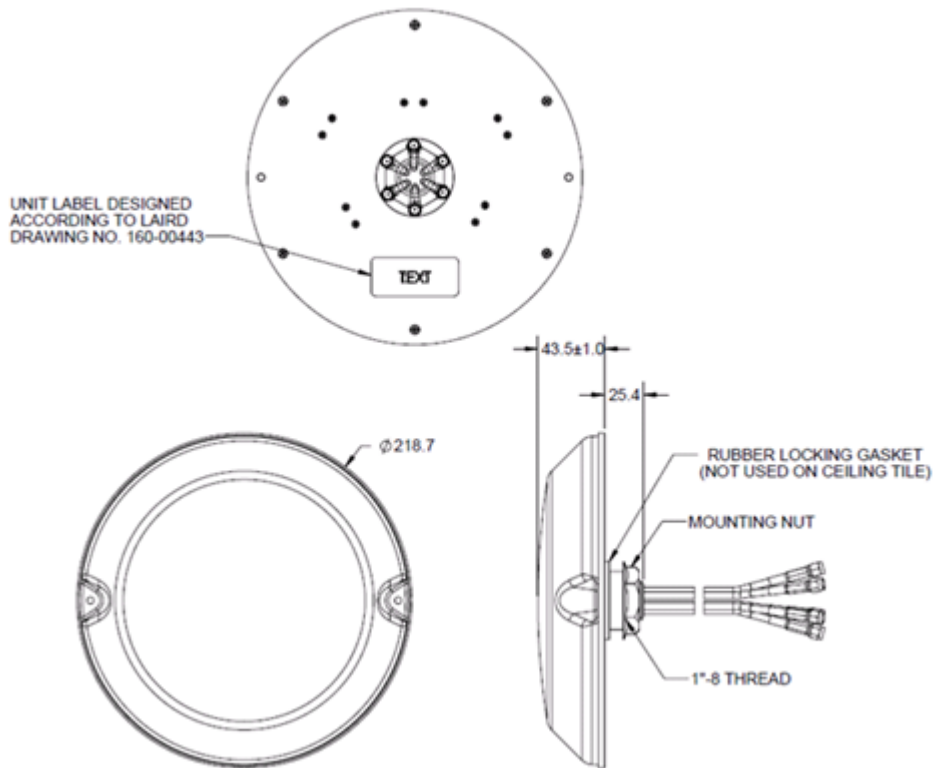

Type	Dual-band MIMO omni patch array, three 2.4G elements, three 5 G elements
Frequency	2400-2500/5150-5850 MHz
Max Gain (dBi)	3.0 / 5.0
Polarization	Linear, Vertical
Azimuth	3 dB Beamwidth: 360 degrees (2.4 GHz) 3 dB Beamwidth: 360 degrees (5 GHz)
Elevation	3 dB Beamwidth: 75 degrees (2.4 GHz) 3 dB Beamwidth: 42 degrees (5 GHz)
Cable Length	91.4 cm
Cable Type	RG-58
Connector Type	RP-SMA Male x 6
Antenna Plenum Rated	No
Cable Plenum Rated	Yes
Outdoor Rated	No
Weight	1.5 lbs
Storage Temp Range (C)	-30 / +70
Operation Temp Range (C)	-30 / +70

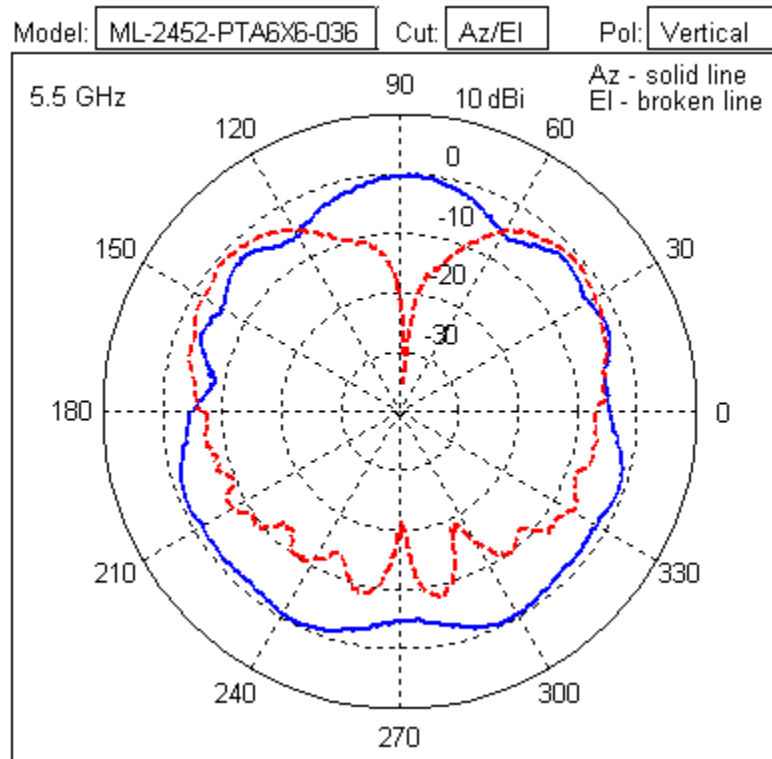
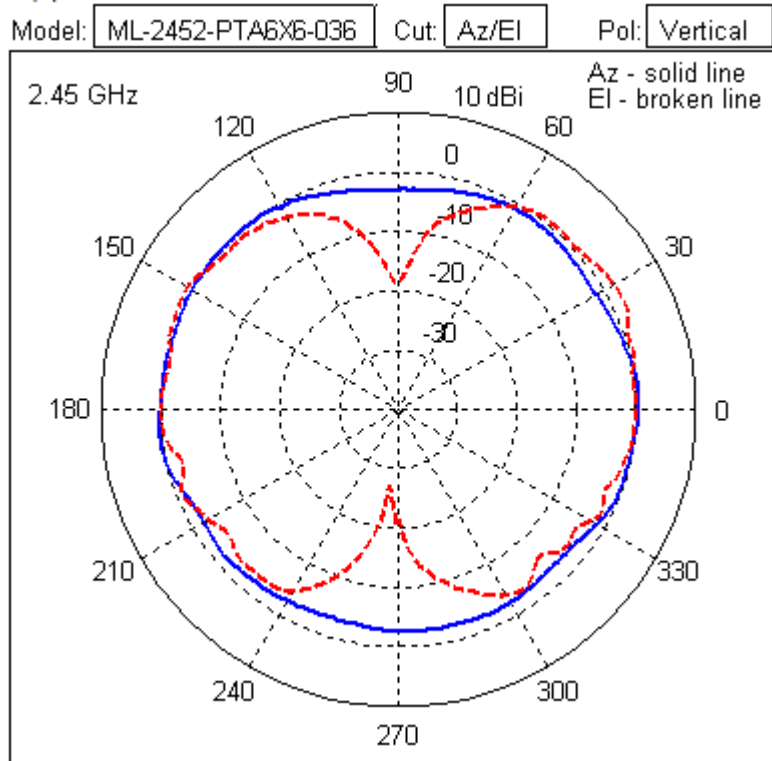

ML-2452-HPA6X6-036 802.11ABG 6-Port Omni Dipole Array, Type N Male x6

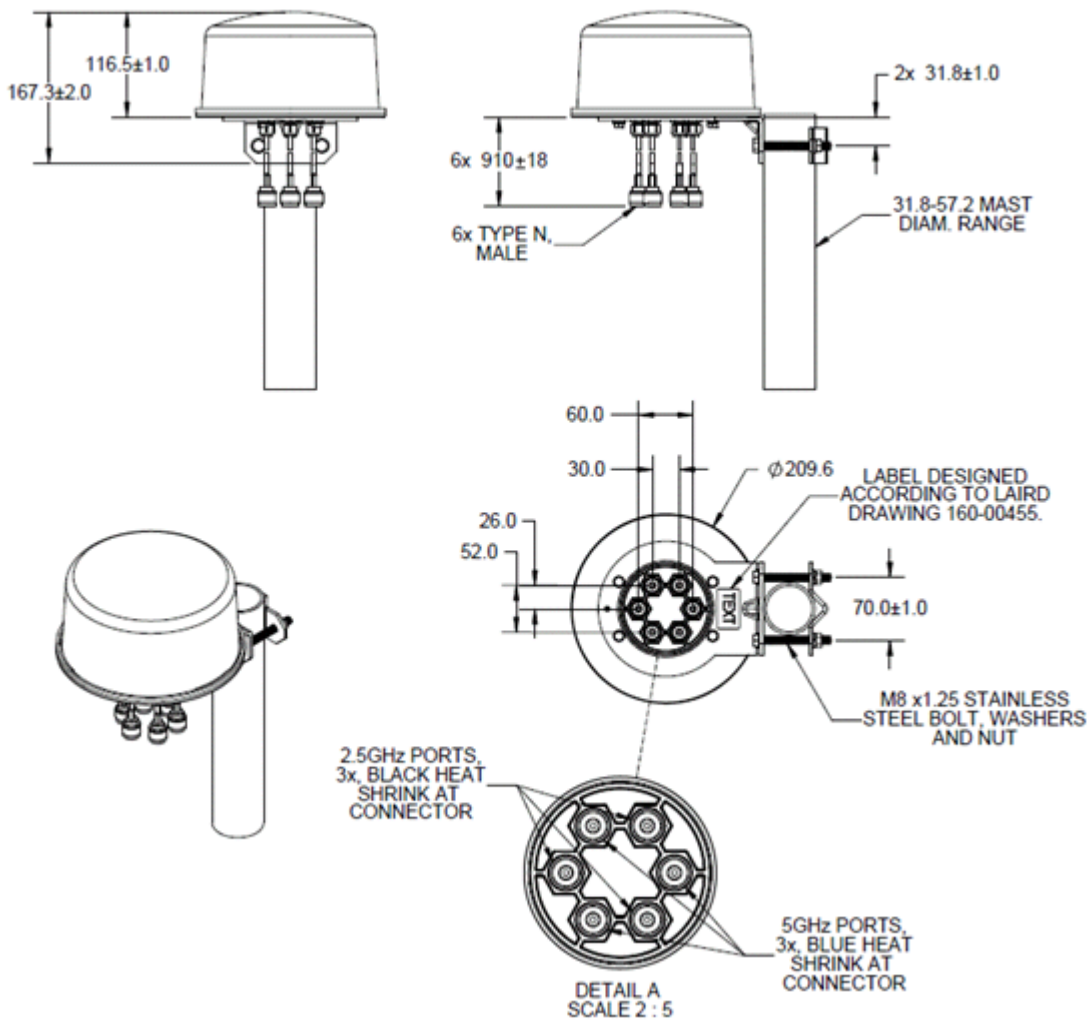

Type	Six-Port Omni Dipole Array (3x2.4G, 3x5G)
Frequency	2400-2500/4900-5900 MHz
Max Gain (dBi)	4.0 /6.0
Elevation Gain (dBi)	-3.9
Polarization	Linear, Vertical
Azimuth	3 dB Beamwidth: 360 degrees (2.4 GHz) 3 dB Beamwidth: 360 degrees (5 GHz)
Elevation	3 dB Beamwidth: 45 degrees (2.4 GHz) 3 dB Beamwidth: 32 degrees (5 GHz)
Max UNII-1 Elevation Gain (dBi)	-3.9
Cable Length	91.0 cm
Cable Type	RG-58

Connector Type	Type N Male x 6
Antenna Plenum Rated	N/A
Cable Plenum Rated	Yes
Outdoor Rated	Yes
Weight	2.5 lbs
Storage Temp Range (C)	-40 / +85
Operation Temp Range (C)	-30 / +70

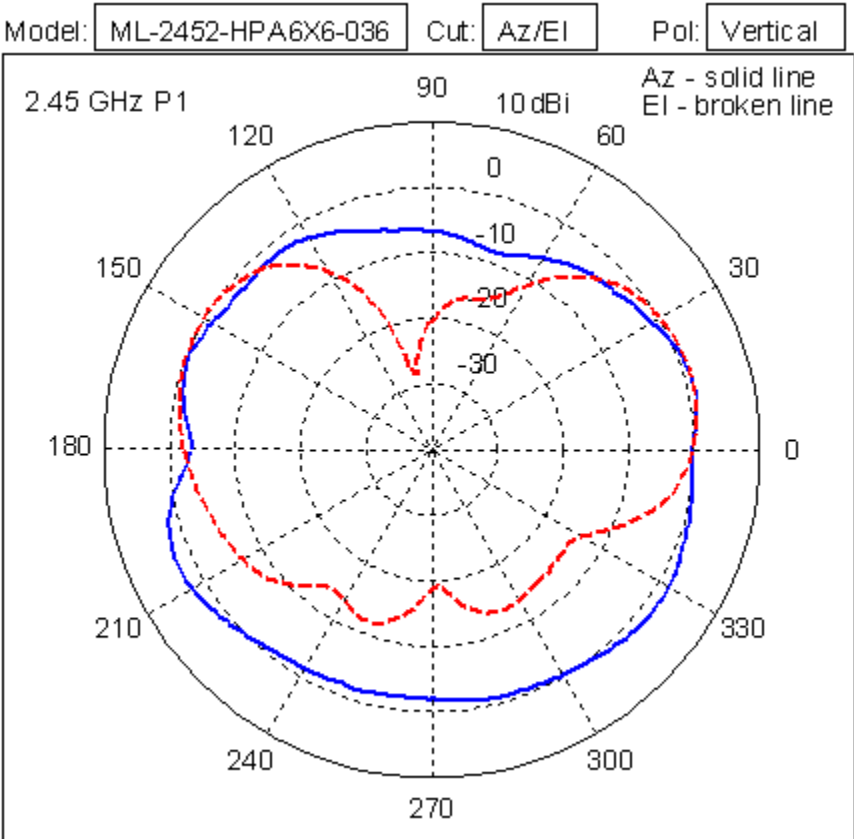
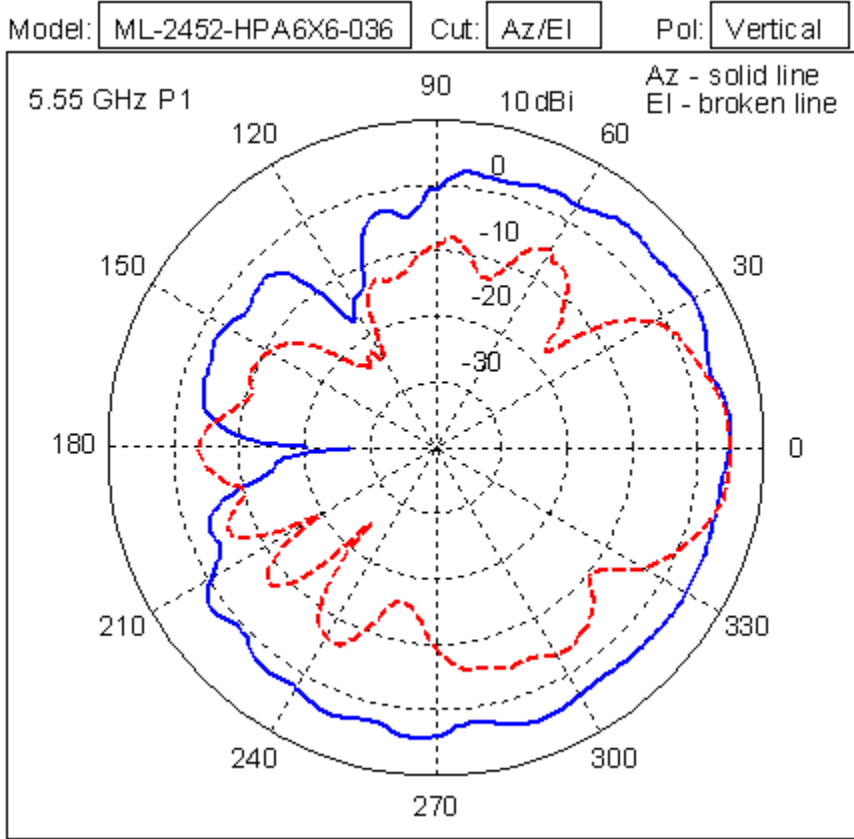

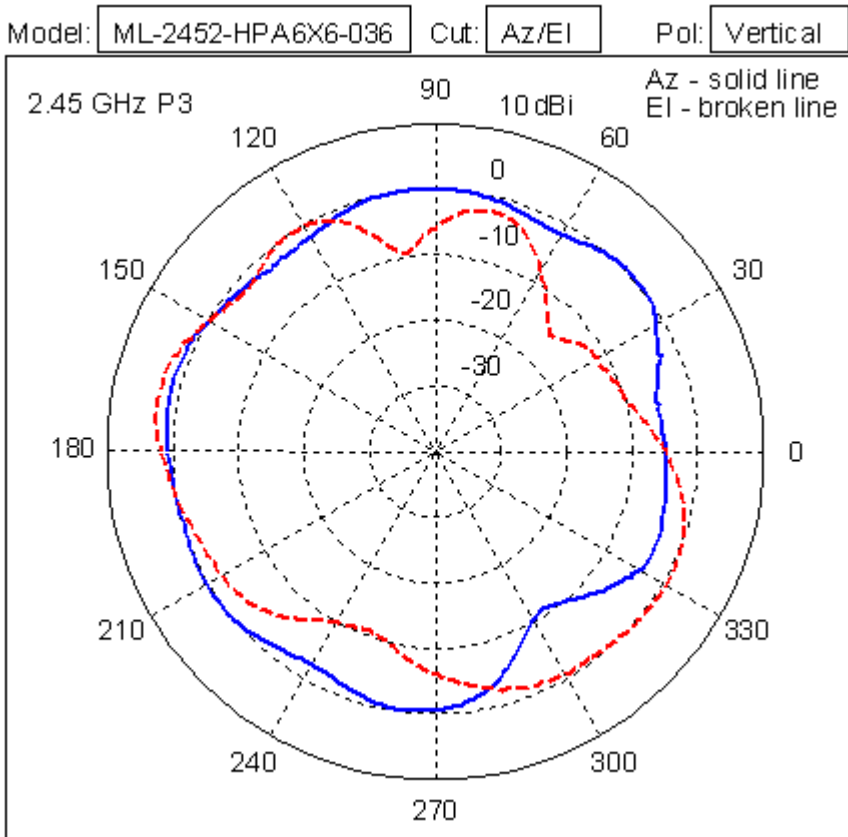
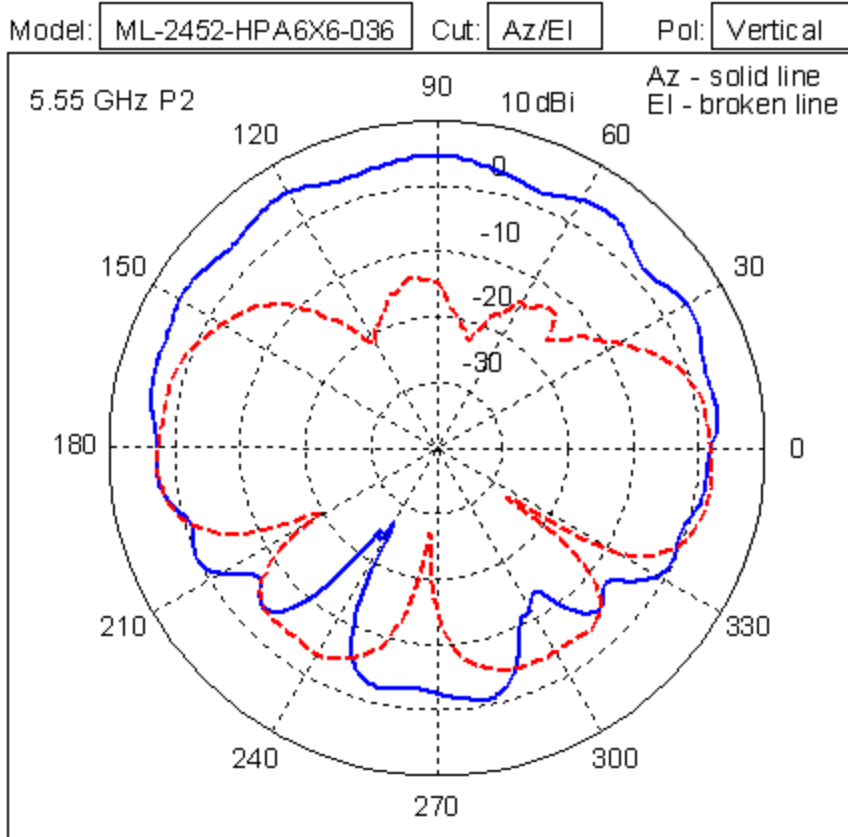

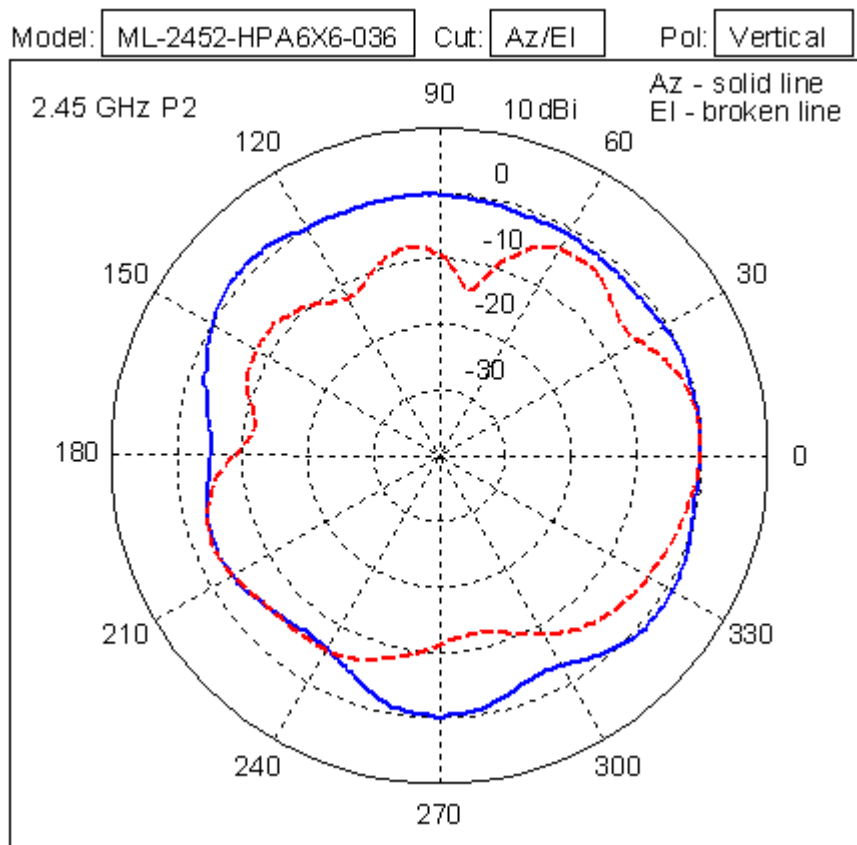
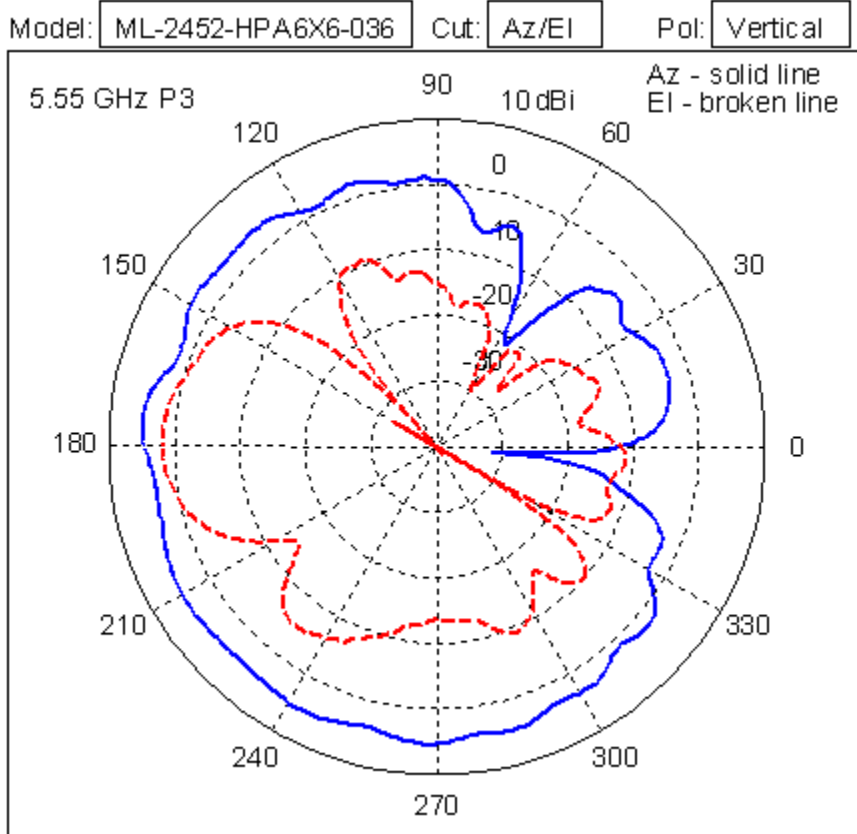

ML-2452-PTA2M2-036 802.11ABG 2-Port Patch Array, RP-SMA Male

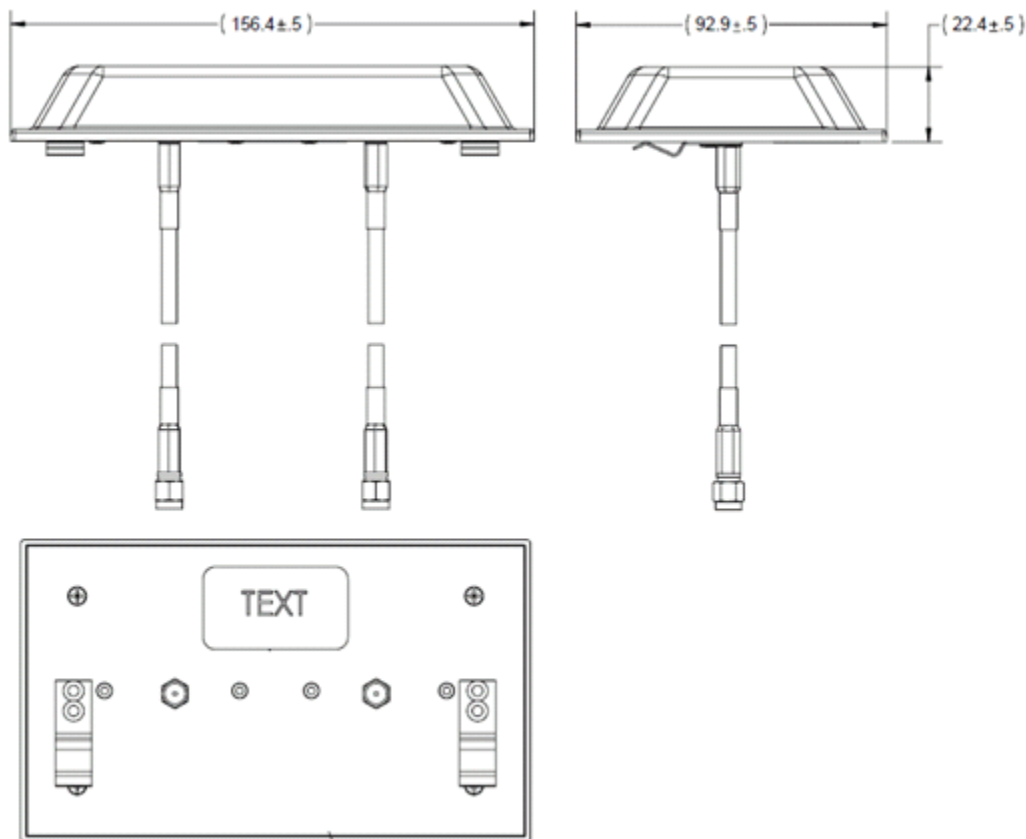

Type	Two-port, dual-band omni patch array
Frequency	2400-2500/4900-5990 MHz
Max Gain (dBi)	4.0 /5.0
Polarization	Linear, Vertical
Azimuth	3 dB Beamwidth: 360 degrees (2.4 GHz) 3 dB Beamwidth: 360 degrees (5 GHz)
Elevation	3 dB Beamwidth: 60 degrees (2.4 GHz) 3 dB Beamwidth: 60 degrees (5 GHz)
Cable Length	91.4 cm
Cable Type	RG-58
Connector Type	RP-SMA Male
Antenna Plenum Rated	No
Cable Plenum Rated	Yes
Outdoor Rated	No
Weight	0.5 lbs

Storage Temp Range (C)	-30 / +70
Operation Temp Range (C)	-30 / +70

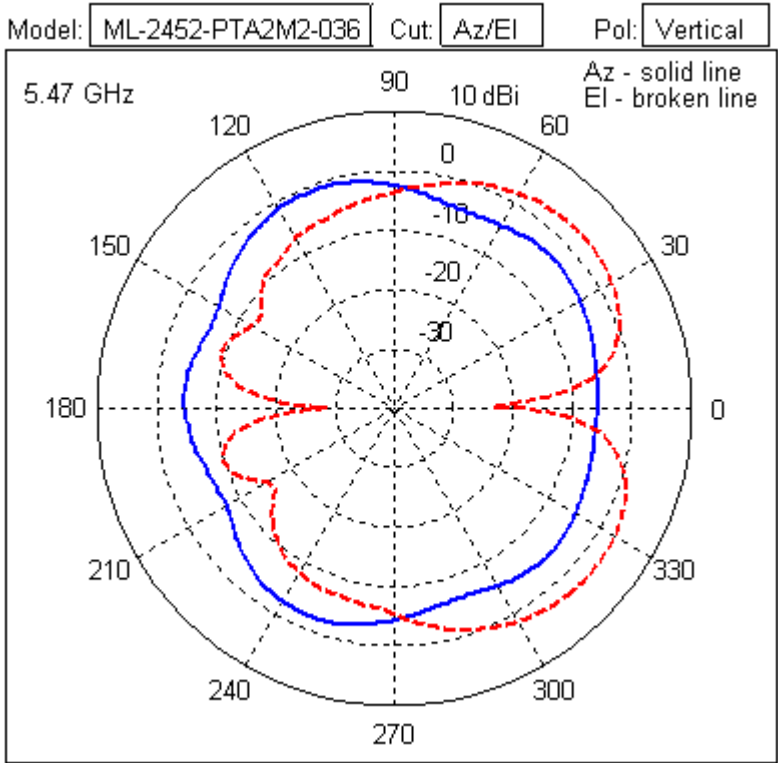
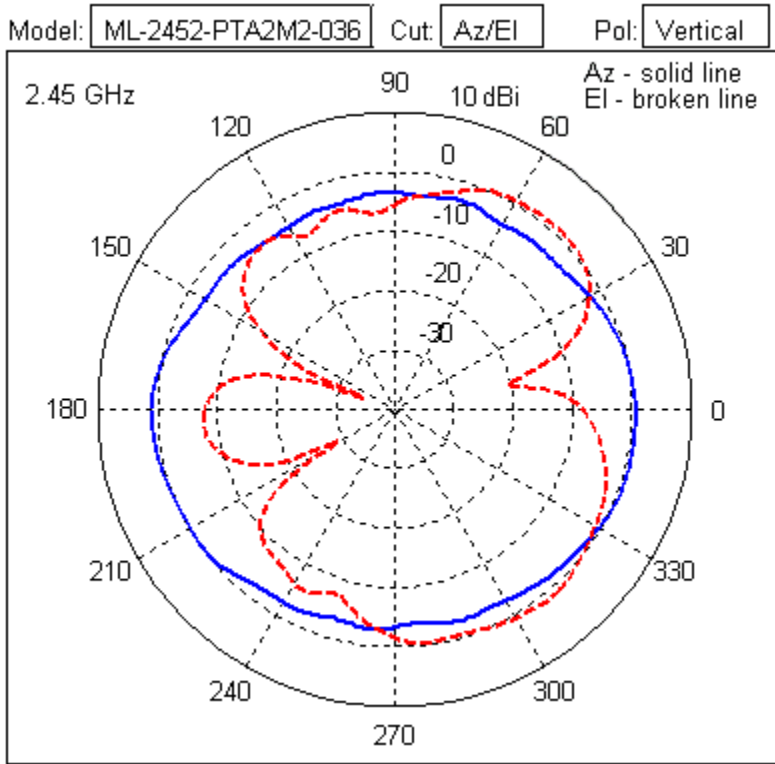

ML-2452-PTA6M6-036 Six-Port Omnidirectional Panel, RP-SMA Male

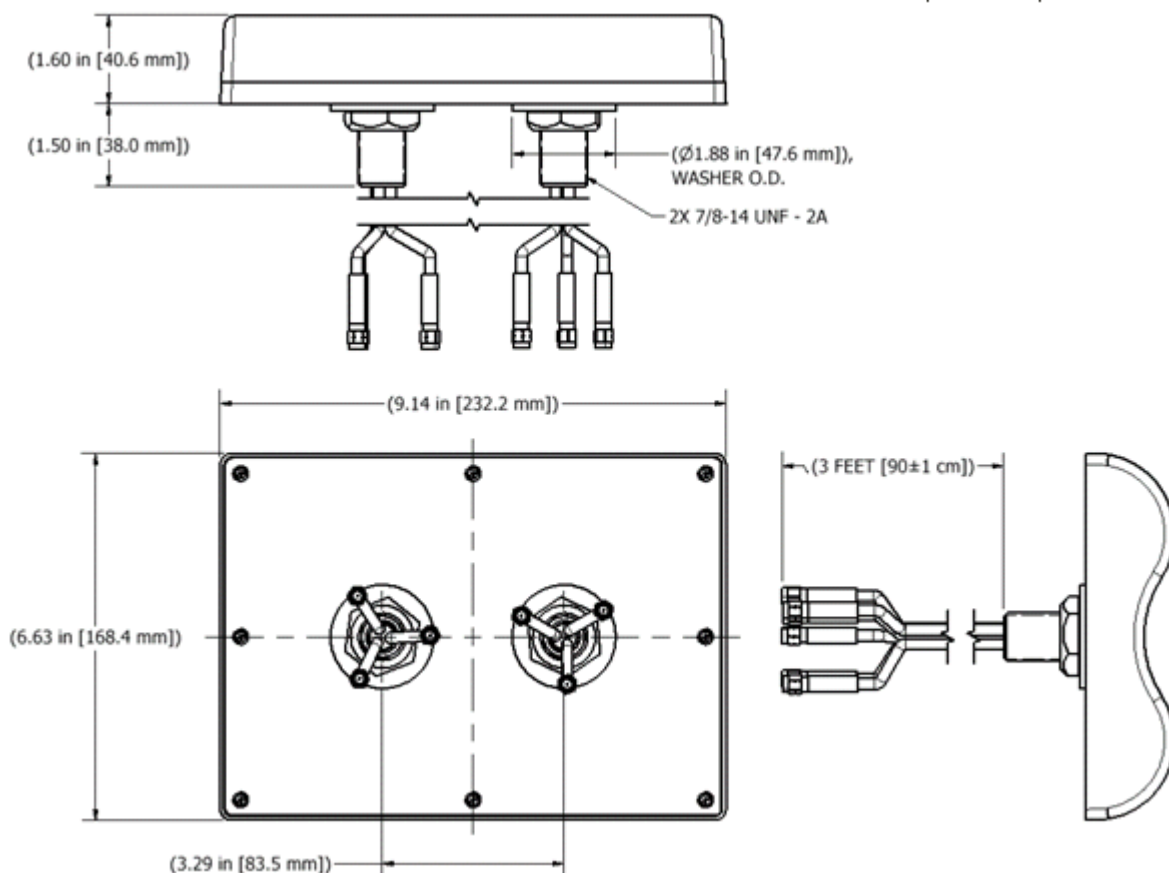

Type	6-Port Dual Band Omnidirectional Panel
Frequency	2400-2500/4900-5900 MHz
Max Gain (dBi)	5.0 /6.0
Polarization	Linear, Vertical
Azimuth	3 dB Beamwidth: 360 degrees (2.4 GHz) 3 dB Beamwidth: 360 degrees (5 GHz)
Elevation	3 dB Beamwidth: 55 degrees (2.4 GHz) 3 dB Beamwidth: 45 degrees (5 GHz)
Cable Length	90 cm
Cable Type	RG-58
Connector Type	RP-SMA Male
Antenna Plenum Rated	N/A
Cable Plenum Rated	Yes
Outdoor Rated	No
Weight	1.5 lbs

Storage Temp Range (C)	-40 / +80
Operation Temp Range (C)	-30 / +70

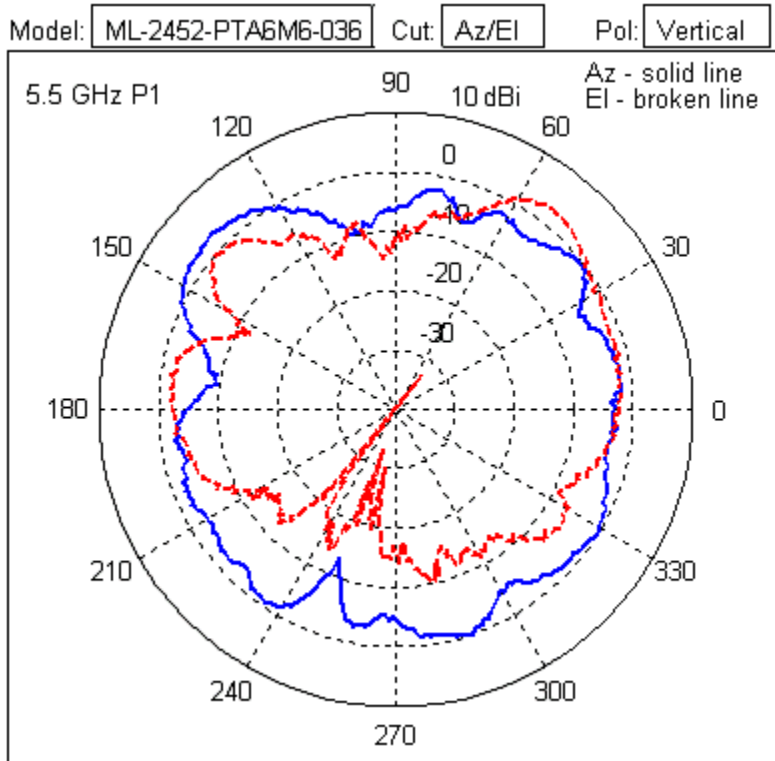
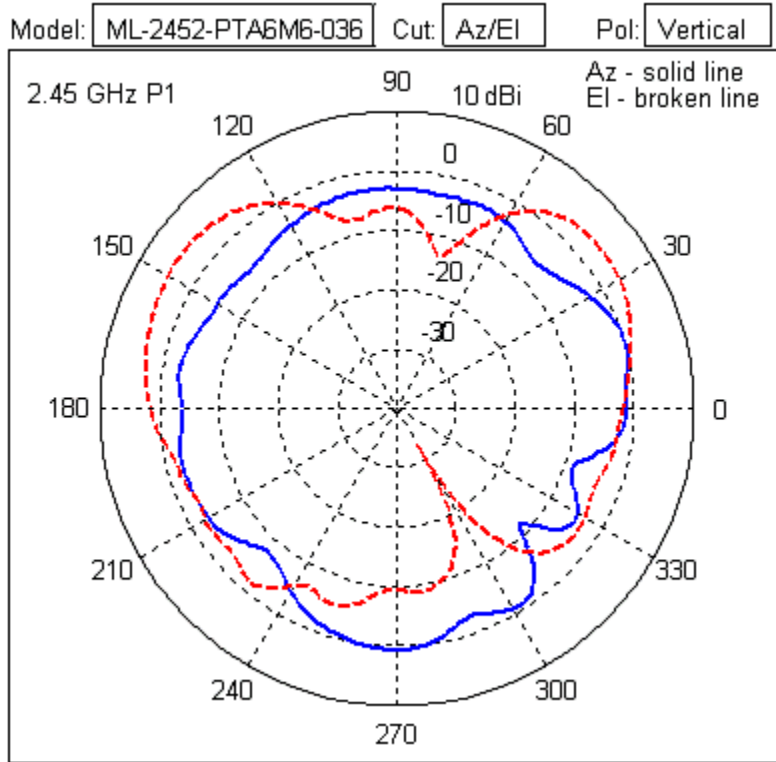

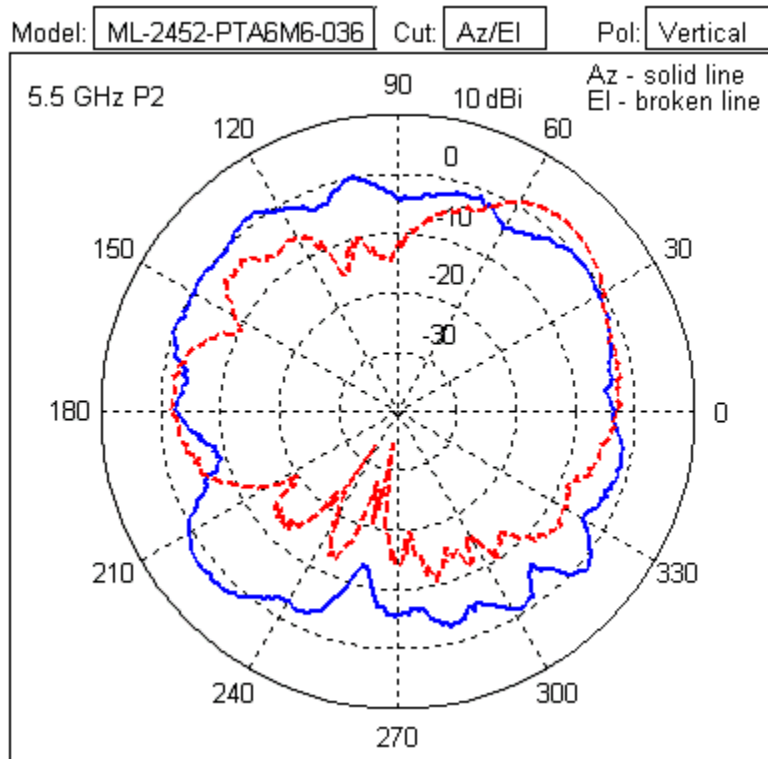
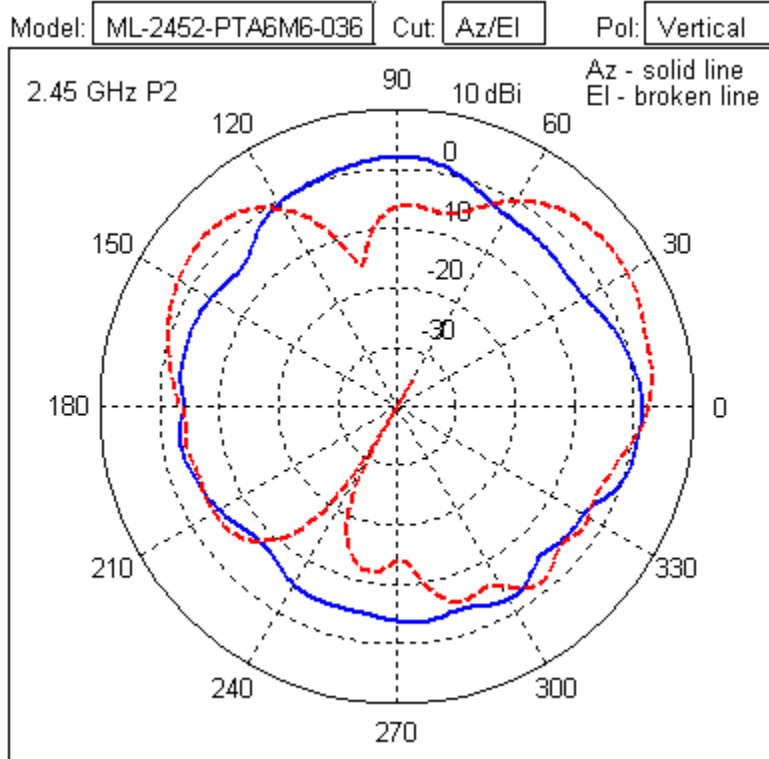

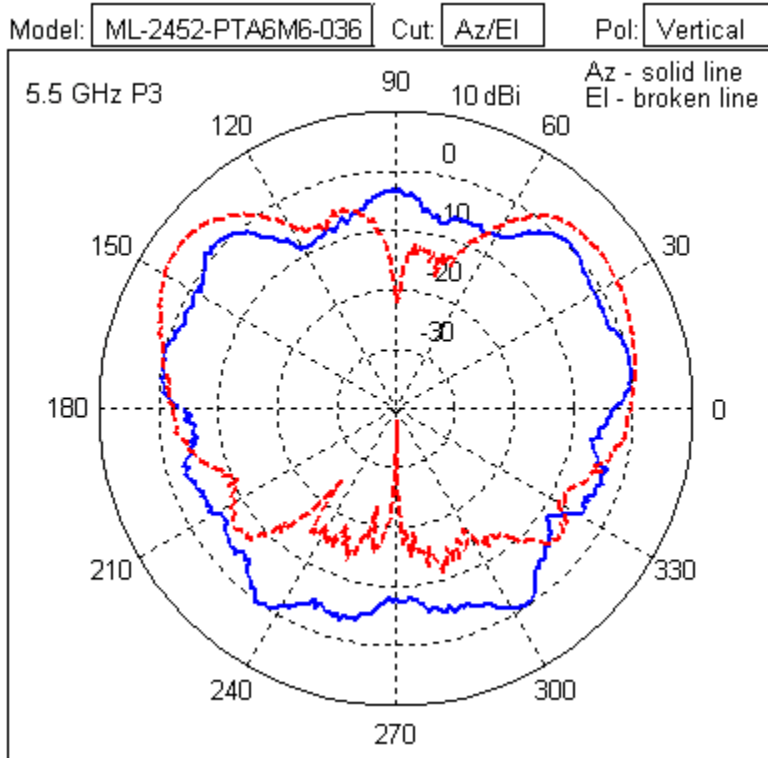
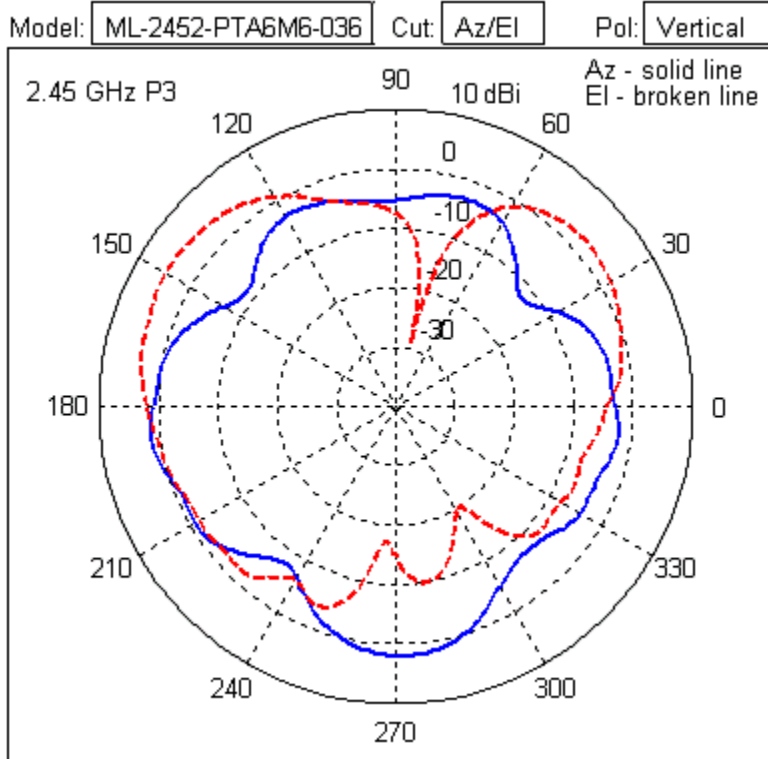

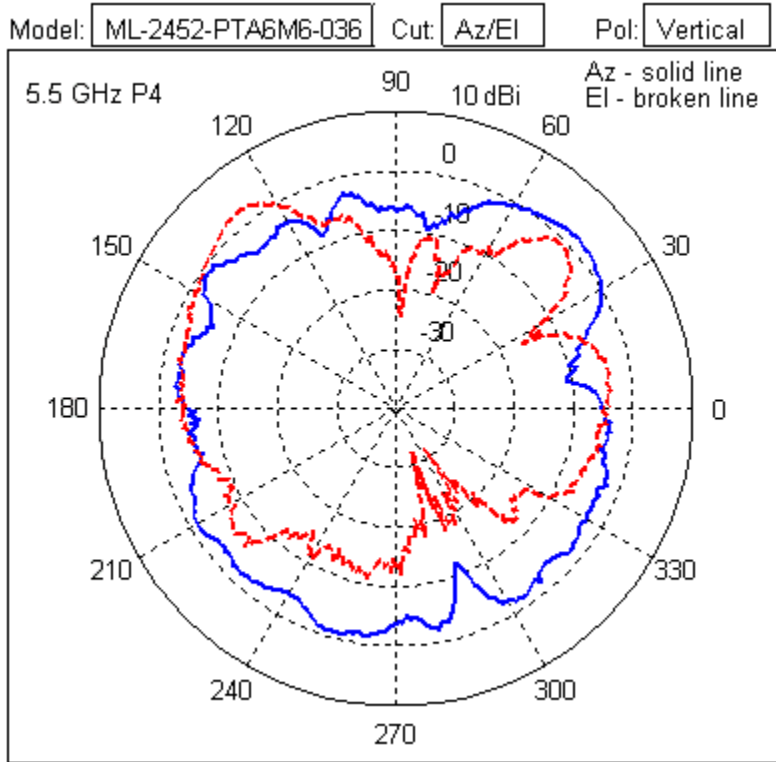
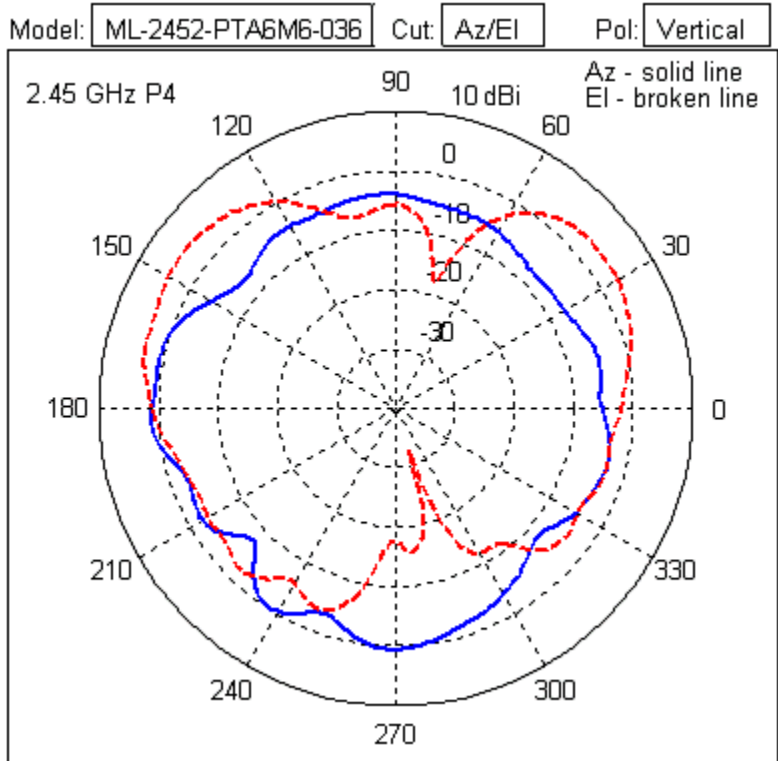

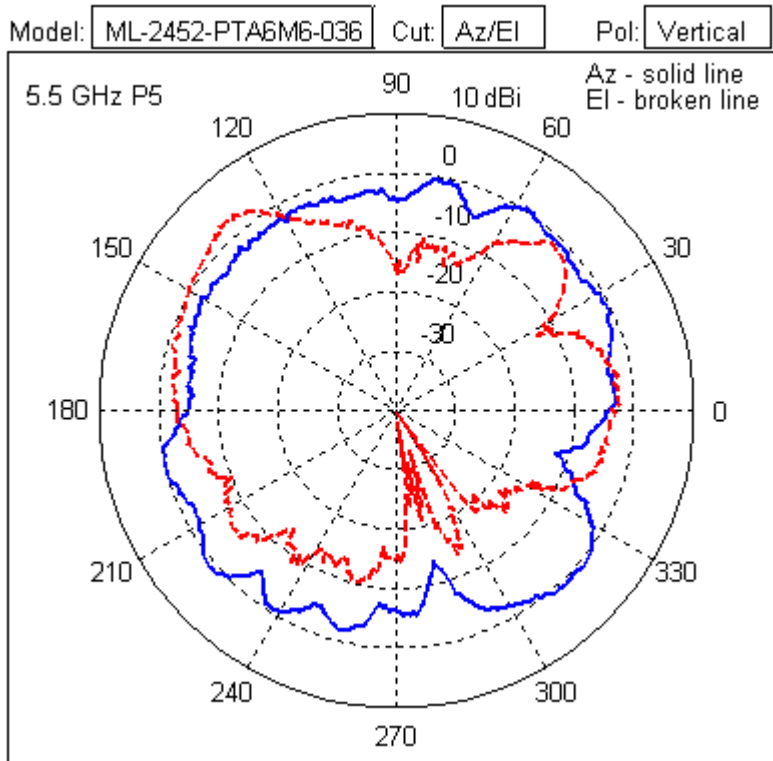
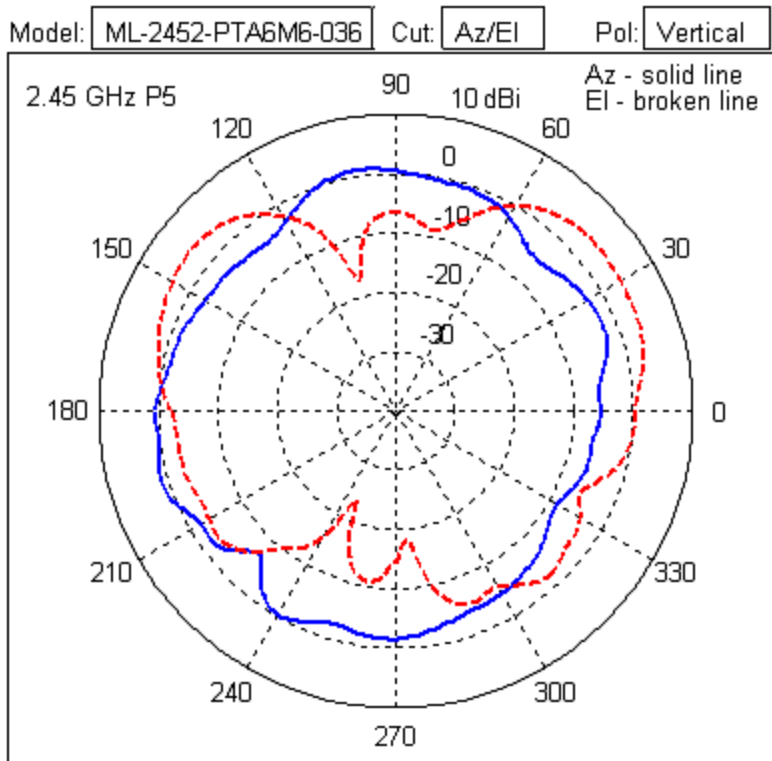

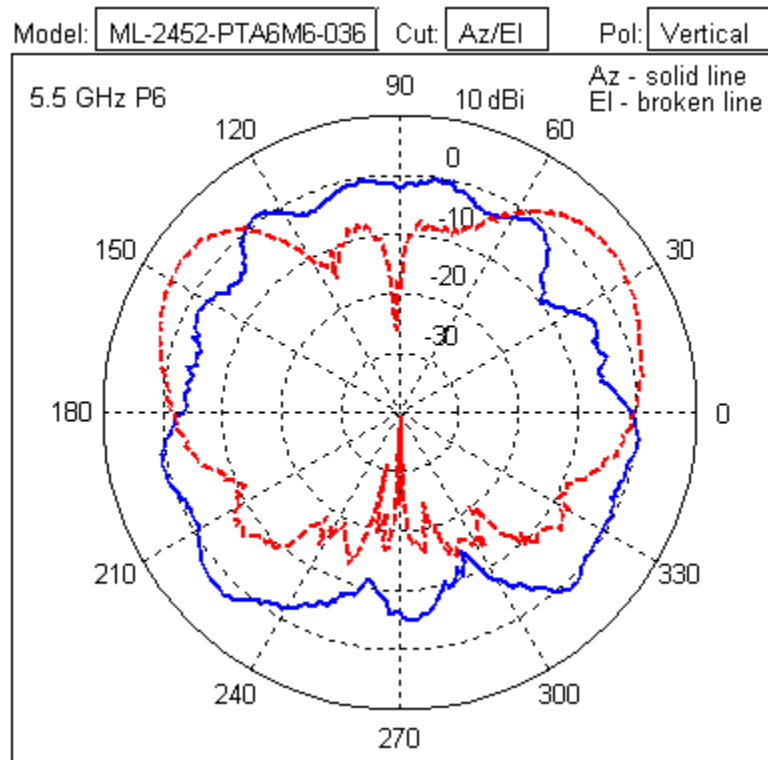
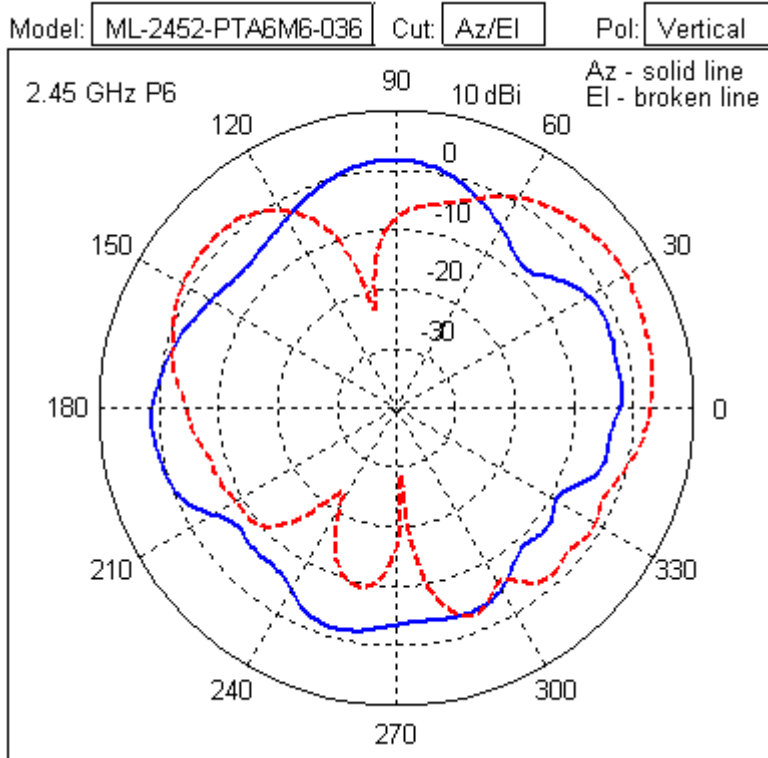

ML-2452-PTA6M6-1 Six-Port Facade Antenna, RP-SMA Male

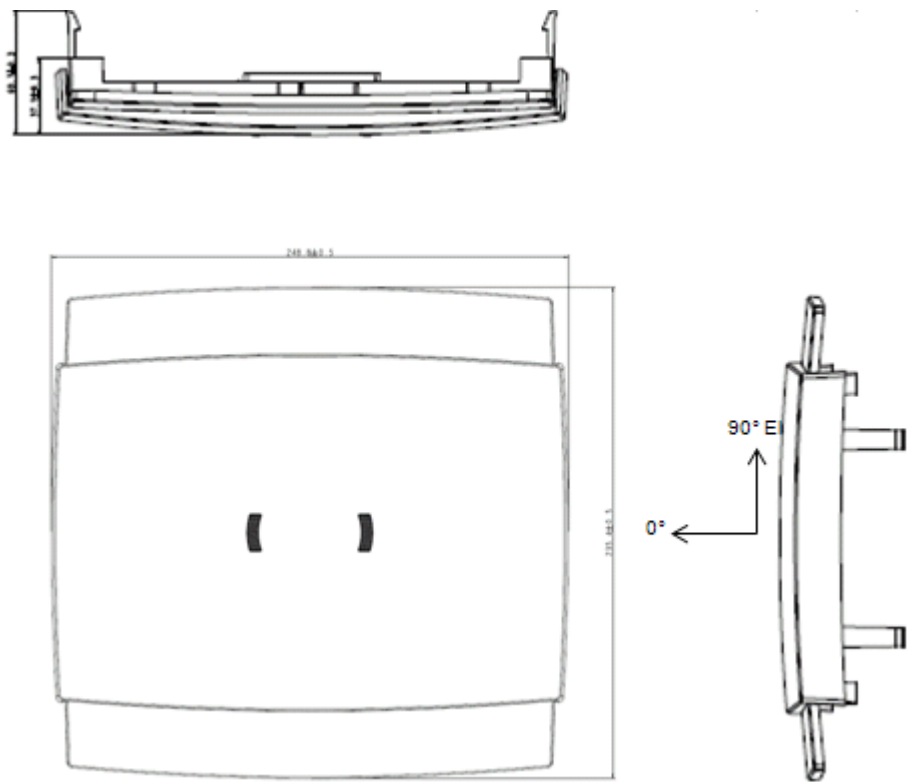

Type	6-Port Facade Antenna
Frequency	2400-2500/5150-5950 MHz
Max Gain (dBi)	3.5/4.0
Polarization	Linear, Vertical
Azimuth	3 dB Beamwidth: 360 degrees (2.4 GHz) 3 dB Beamwidth: 360 degrees (5 GHz)
Elevation	3 dB Beamwidth: 180 degrees (2.4 GHz) 3 dB Beamwidth: 180 degrees (5 GHz)
Cable Length	8.0 cm
Cable Type	1.37 mm coax
Connector Type	RP-SMA Male x 6
Antenna Plenum Rated	No
Cable Plenum Rated	No
Outdoor Rated	No
Weight	0.46 kc/s
Storage Temp Range (C)	-40 / +70
Operation Temp Range (C)	-20 / +70



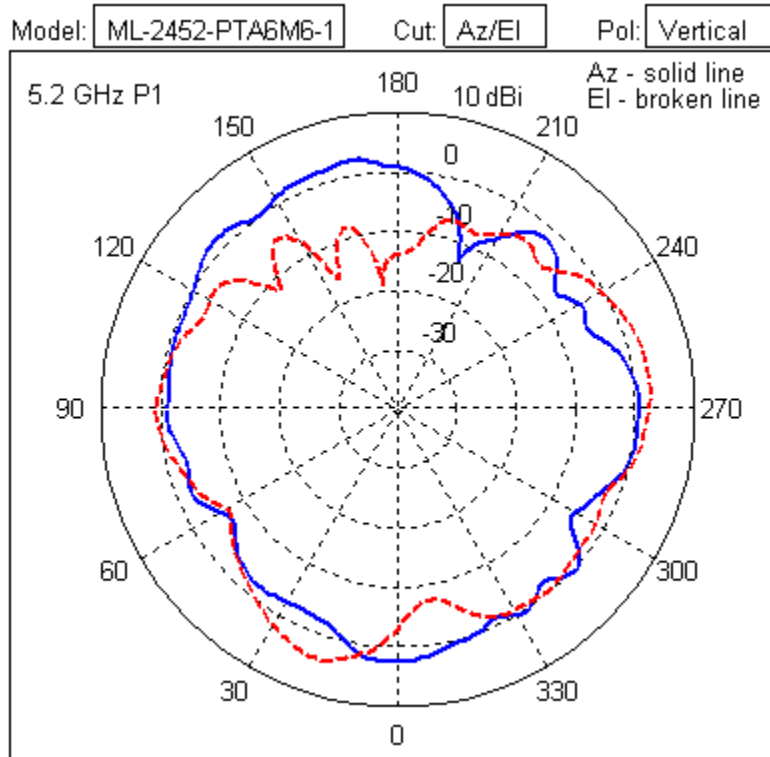
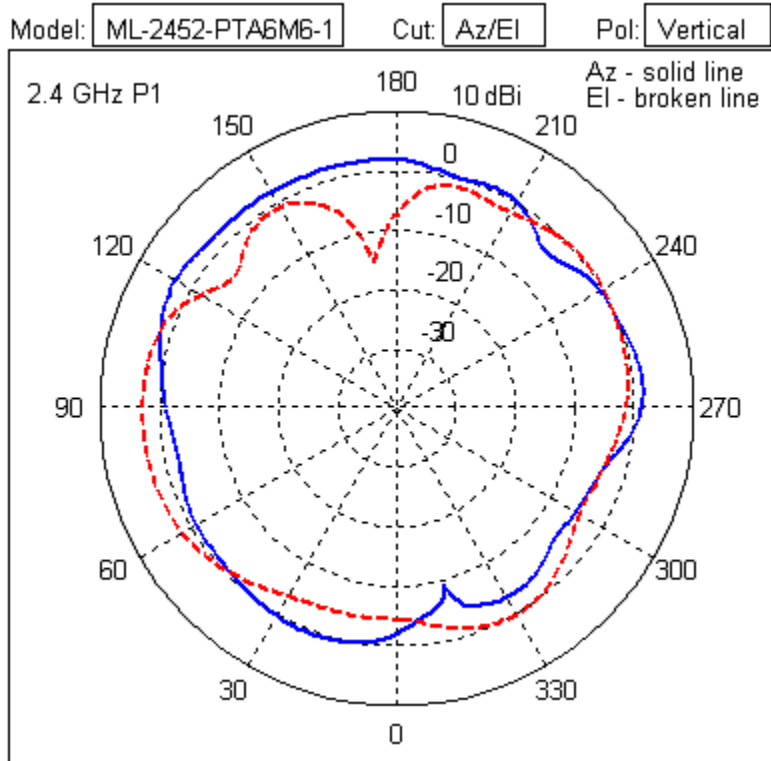

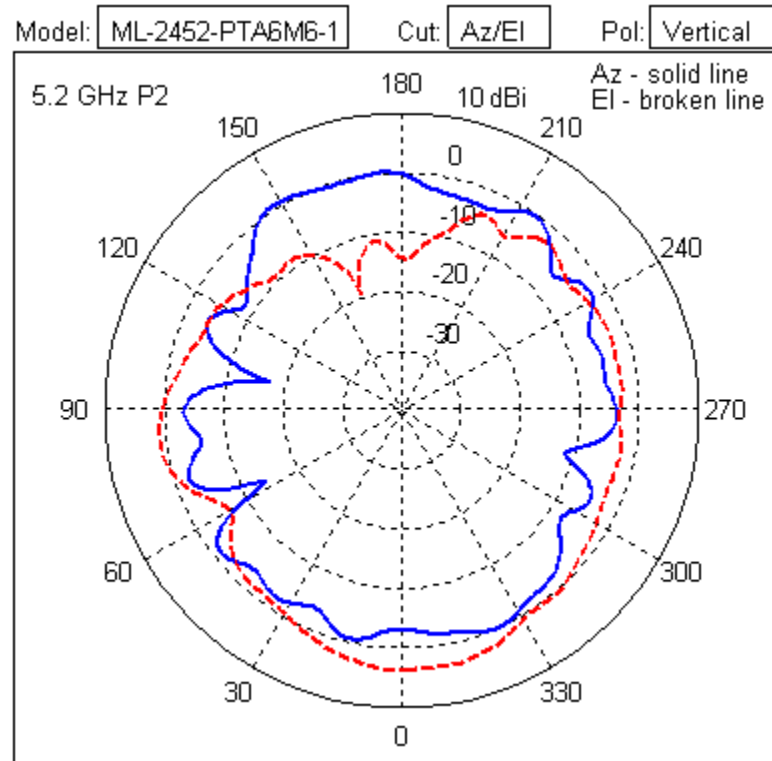
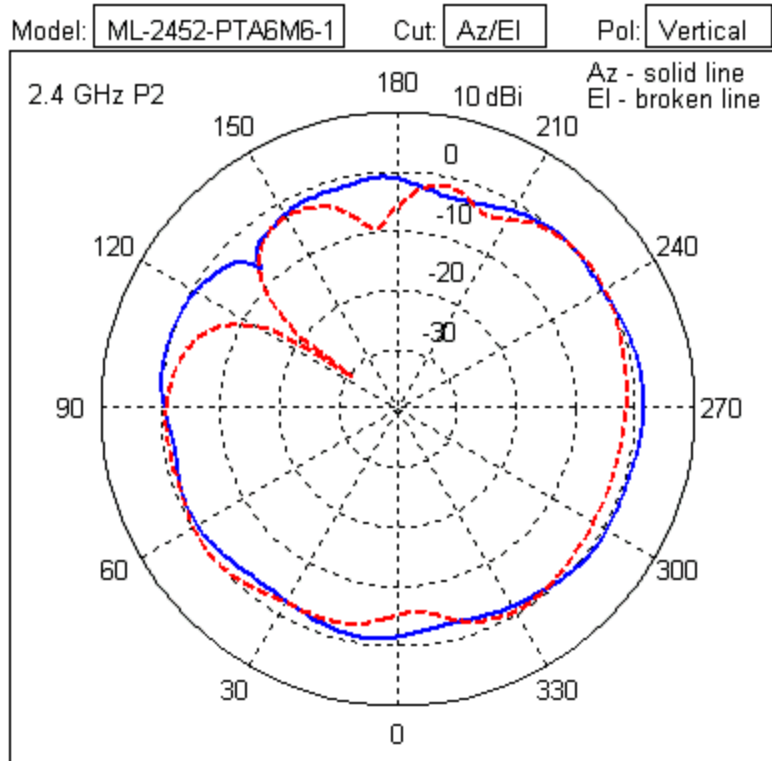

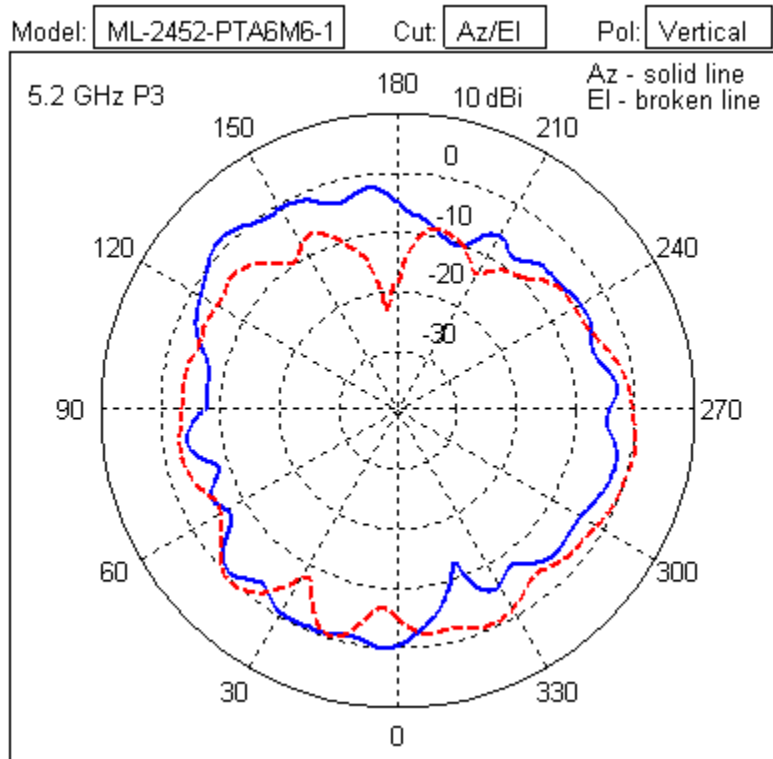
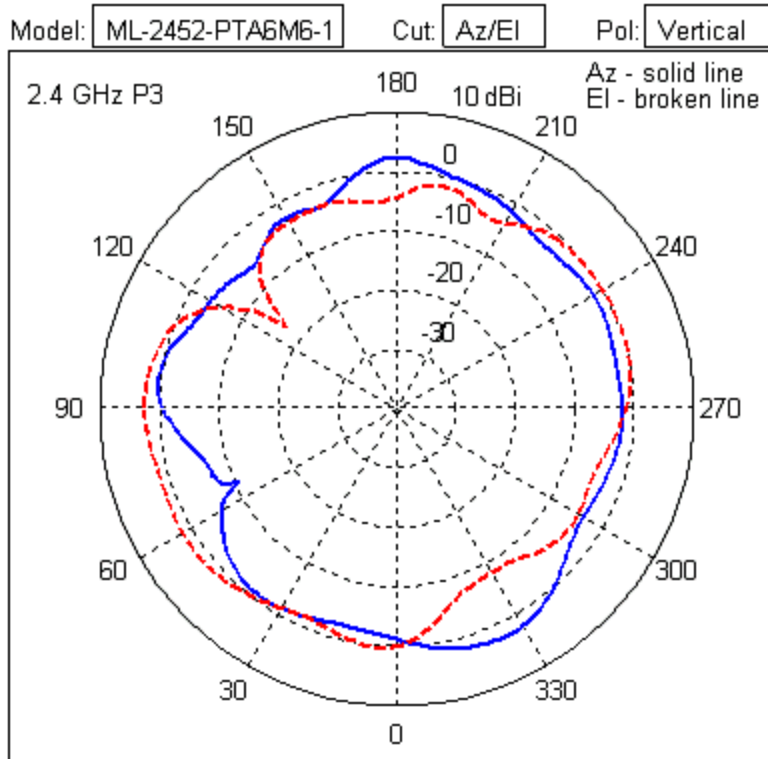

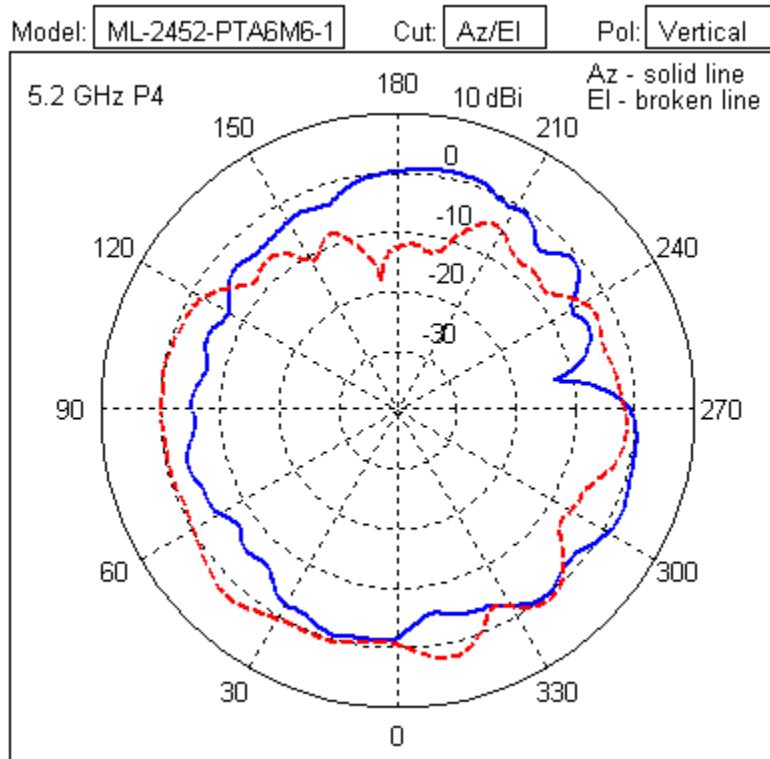
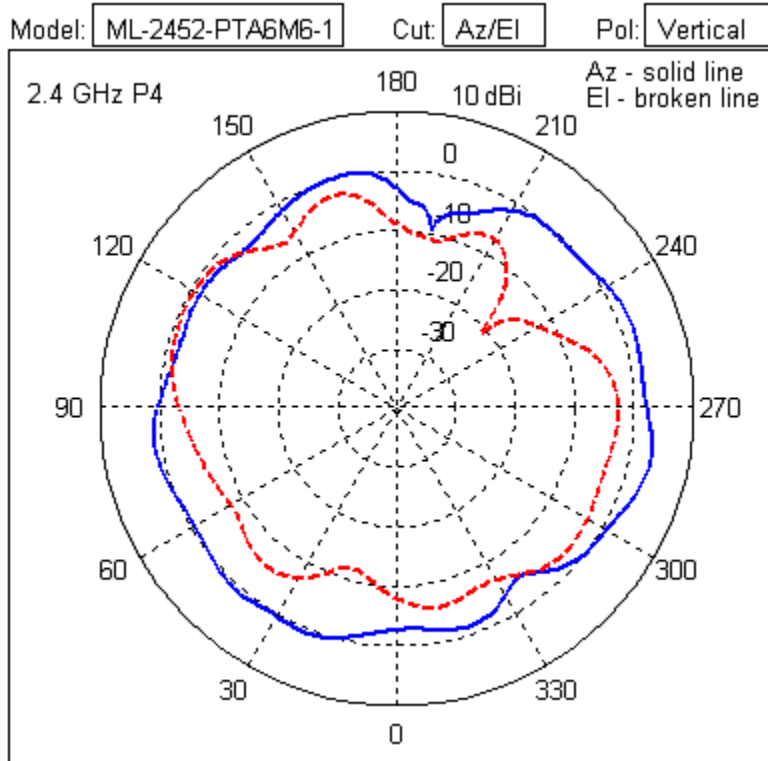

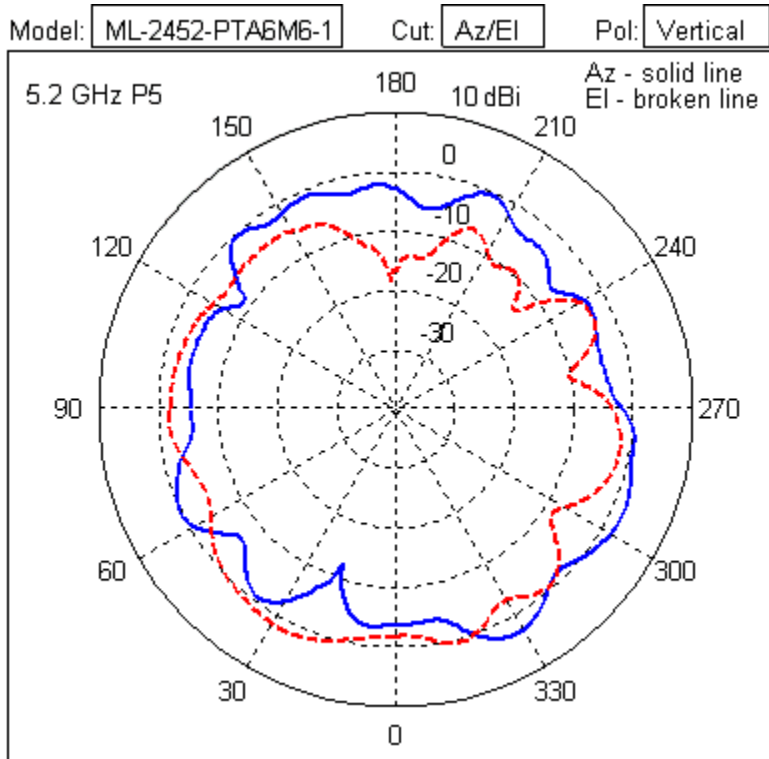
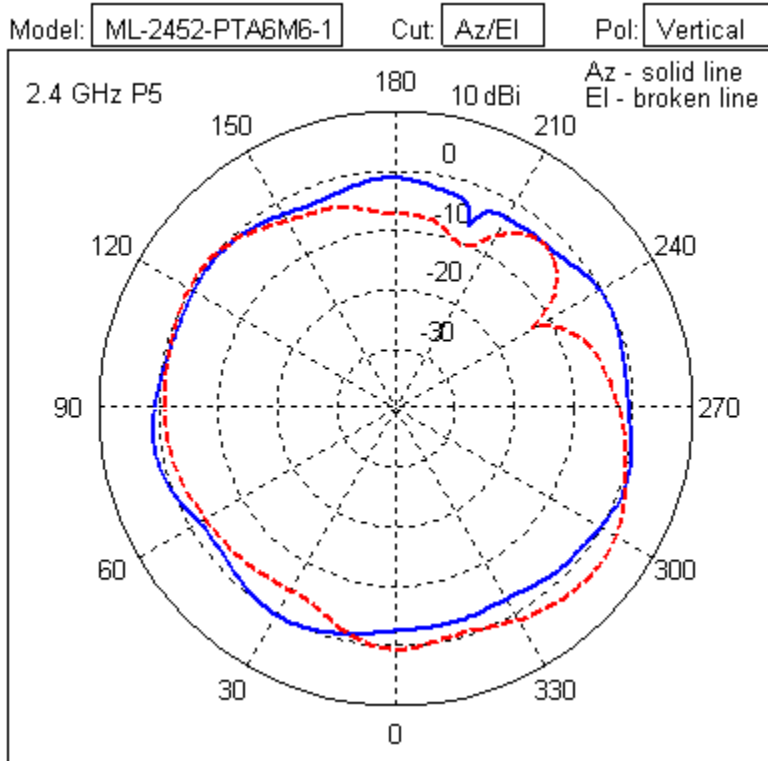

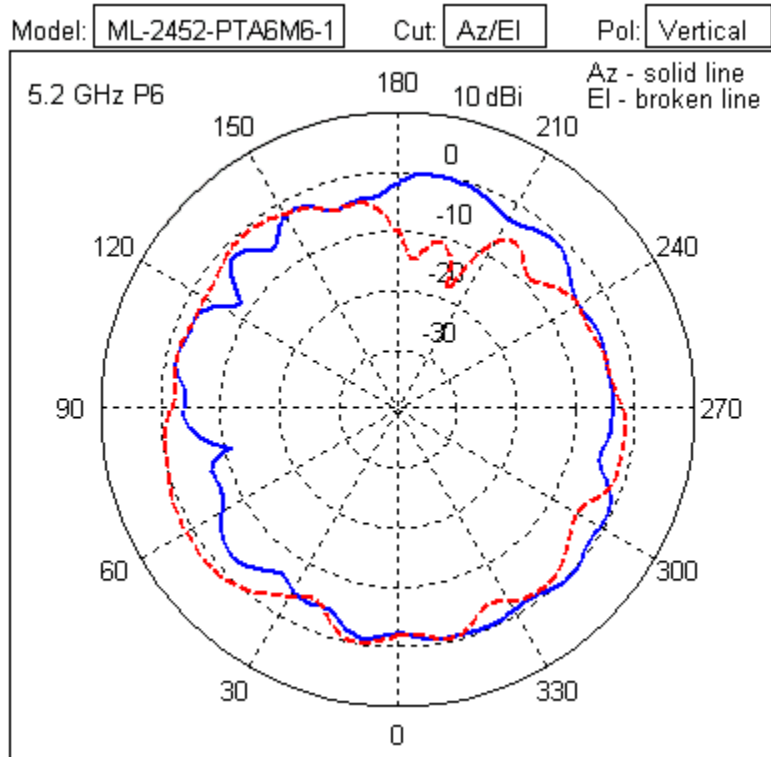
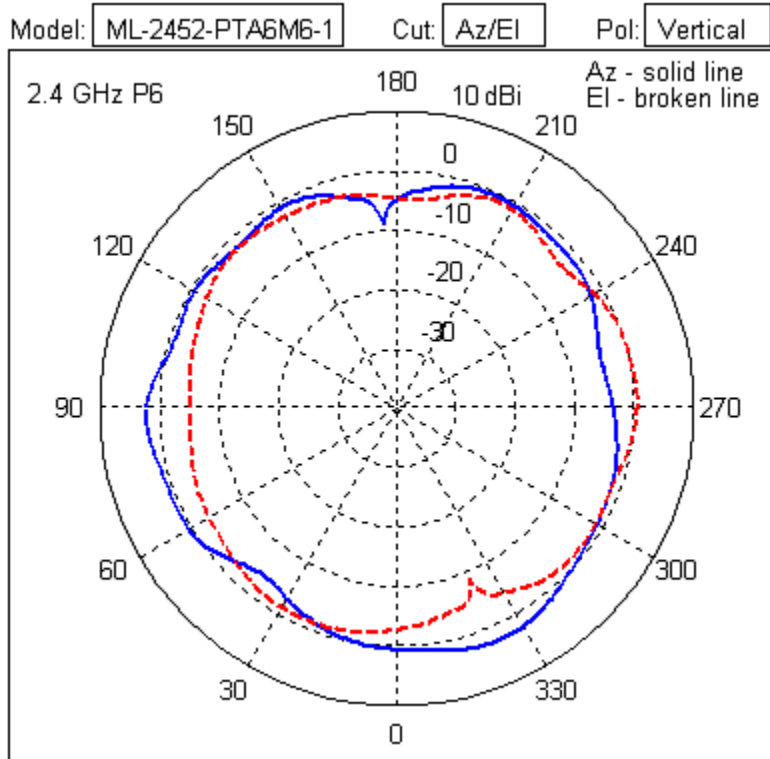

ML-2452-HPA6M6-072 11ABGN, 6P DB Omni, 2.0/4.8 dBi, LP, CBL 72, RP -SMA-M

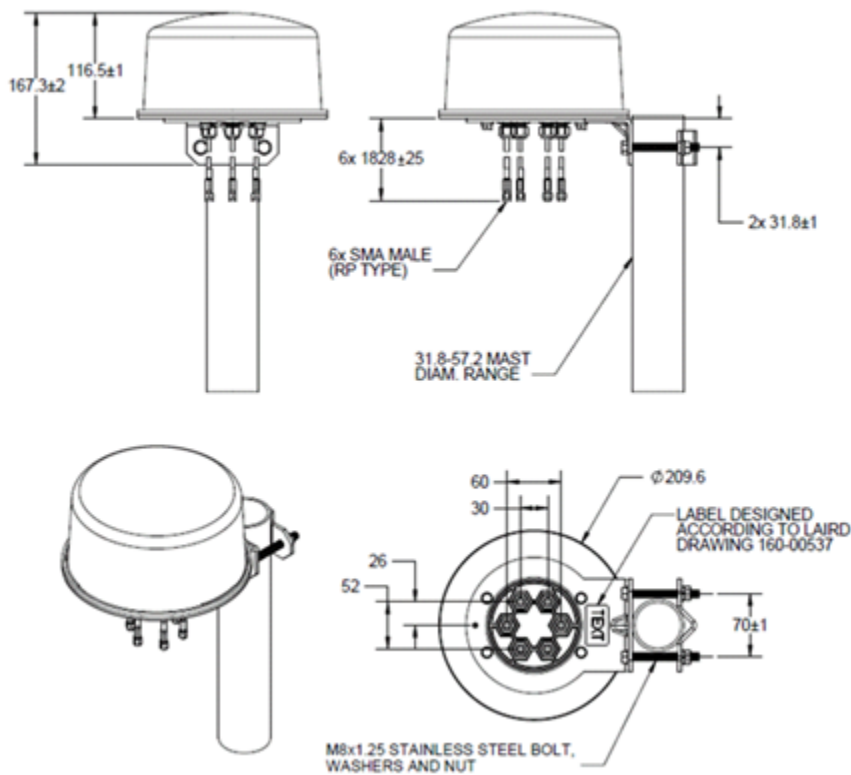

Type	6-Port Dipole Omni Array
Frequency	2400-2500/5150-5875 MHz
Max Gain (dBi)	2.8/6.5
Polarization	Linear, Vertical
Azimuth	3 dB Beamwidth: 360 degrees (2.4 GHz) 3 dB Beamwidth: 360 degrees (5 GHz)
Elevation	3 dB Beamwidth: 66 degrees (2.4 GHz) 3 dB Beamwidth: 30 degrees (5 GHz)
Max UNII-1 Elevation Gain (dBi)	-0.56
Cable Length	182.0 cm
Cable Type	RG-58
Connector Type	SMA-RP-Male x 6
Antenna Plenum Rated	N/A
Cable Plenum Rated	Yes
Outdoor Rated	Yes
Weight	3.35 lbs

Storage Temp Range (C)	-40 / +85
Operation Temp Range (C)	-30 / +70

Model: Cut: Pol:

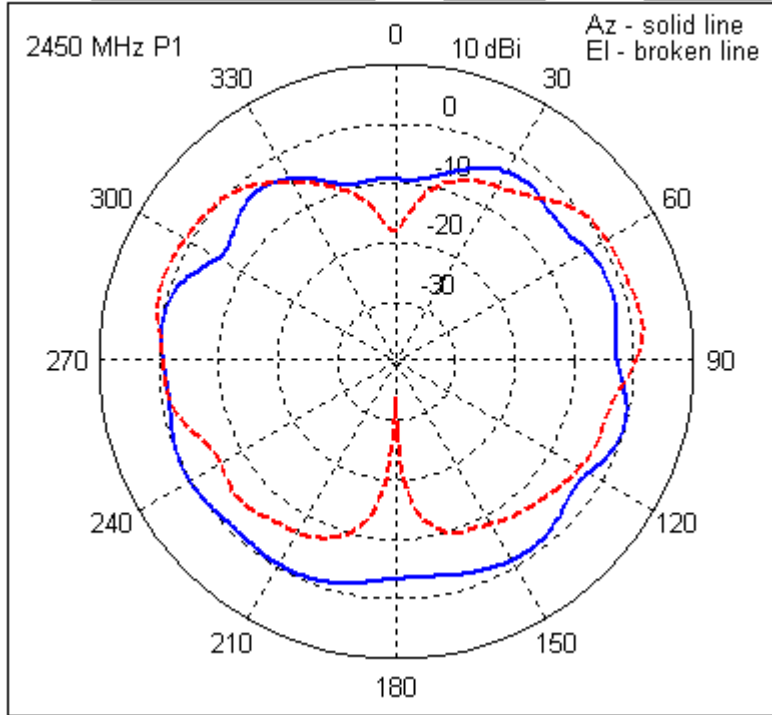

Model: Cut: Pol:

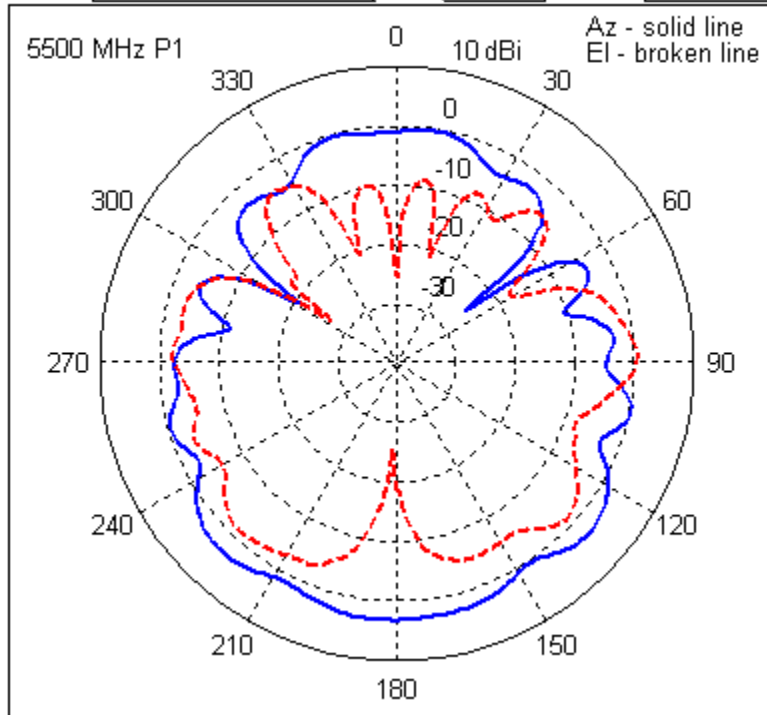

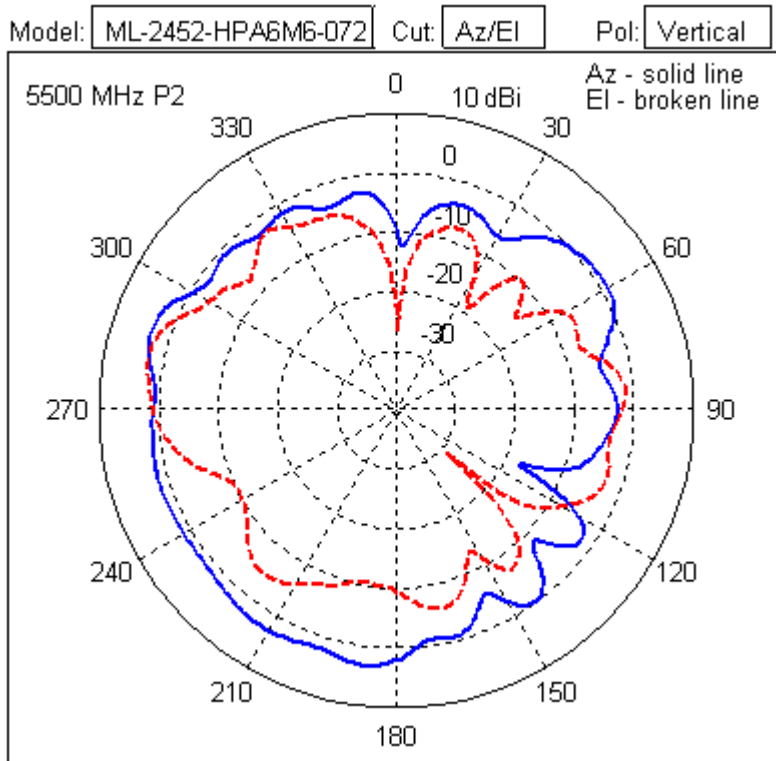
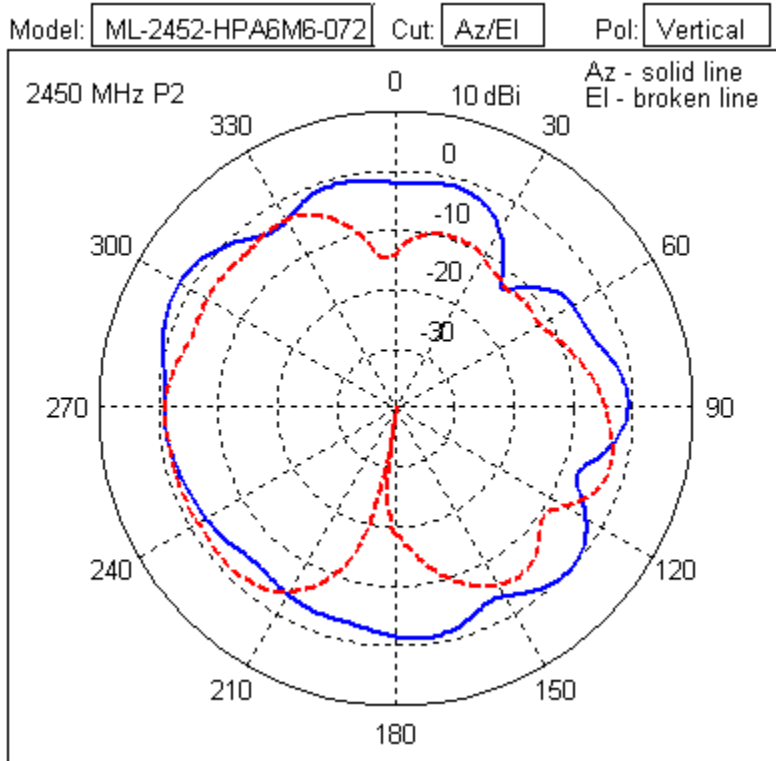

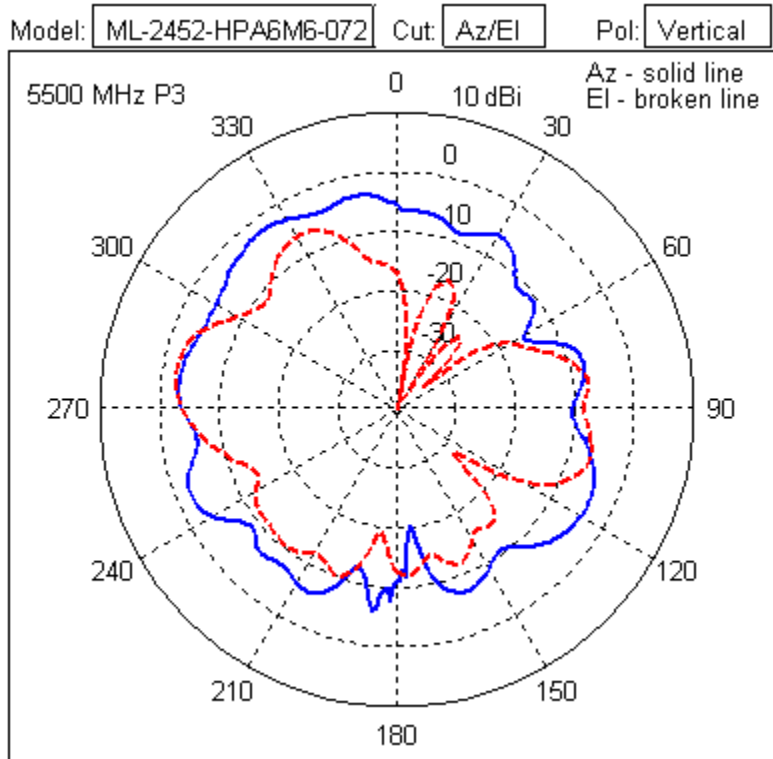
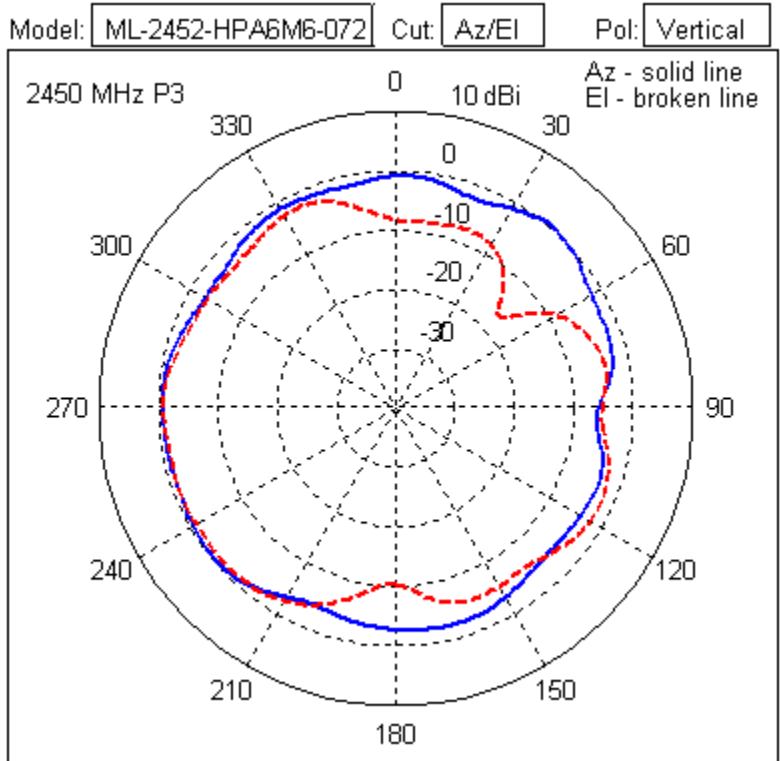

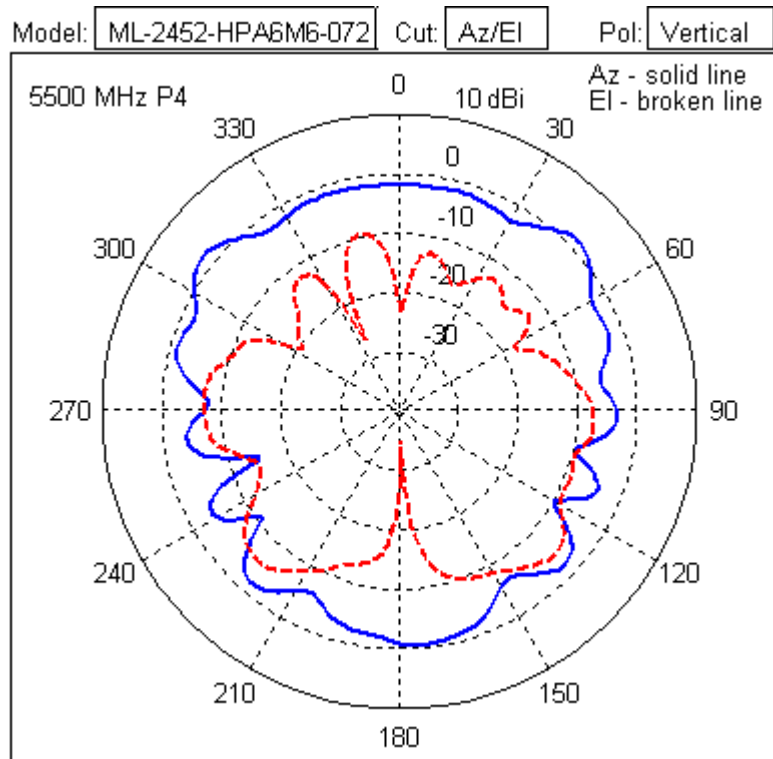
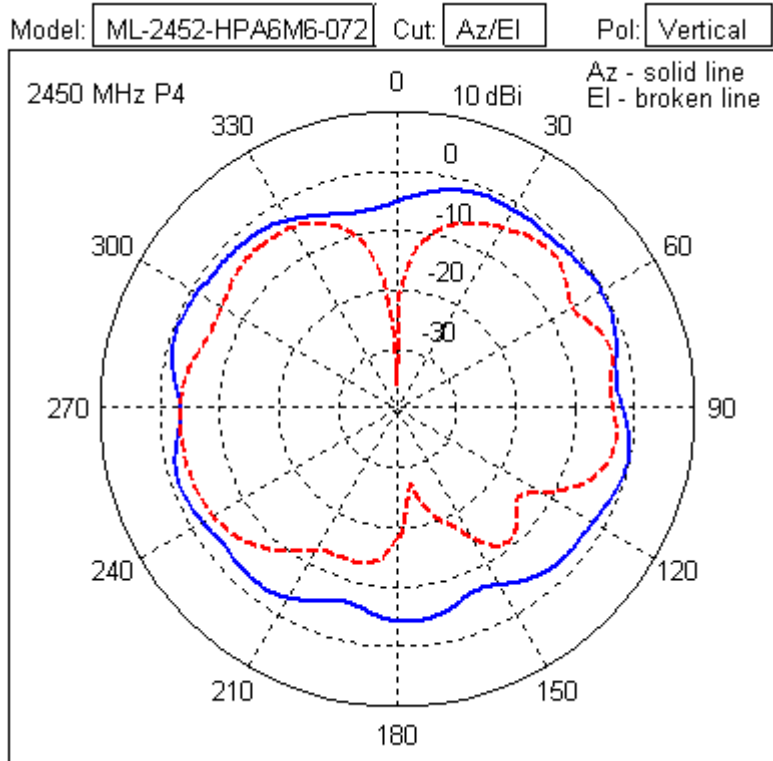

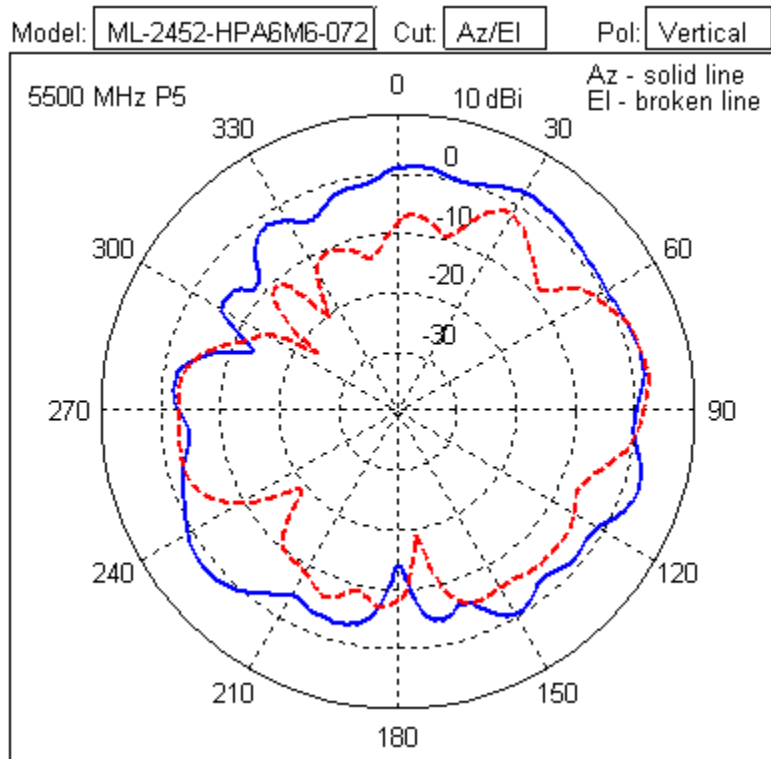
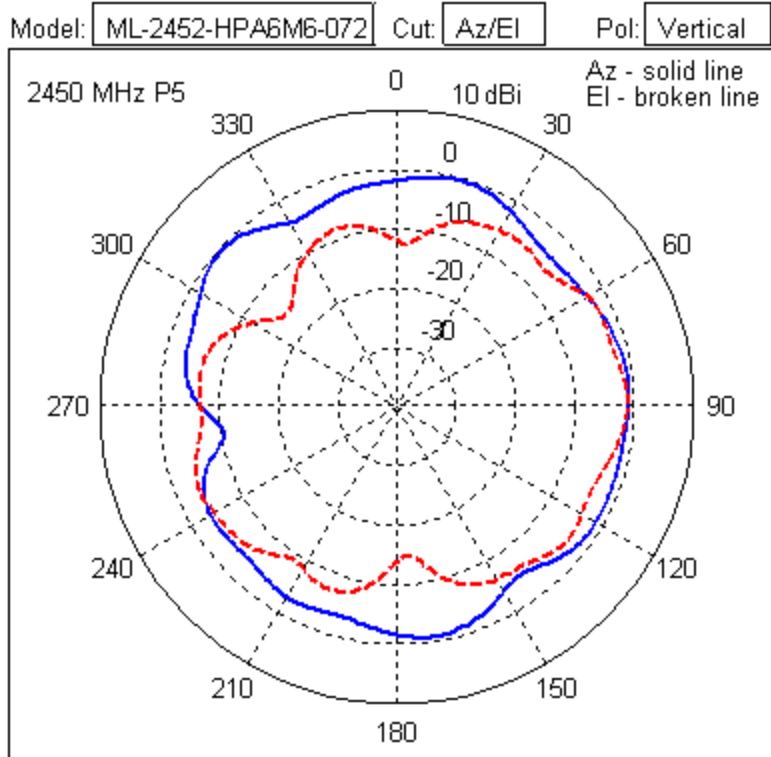

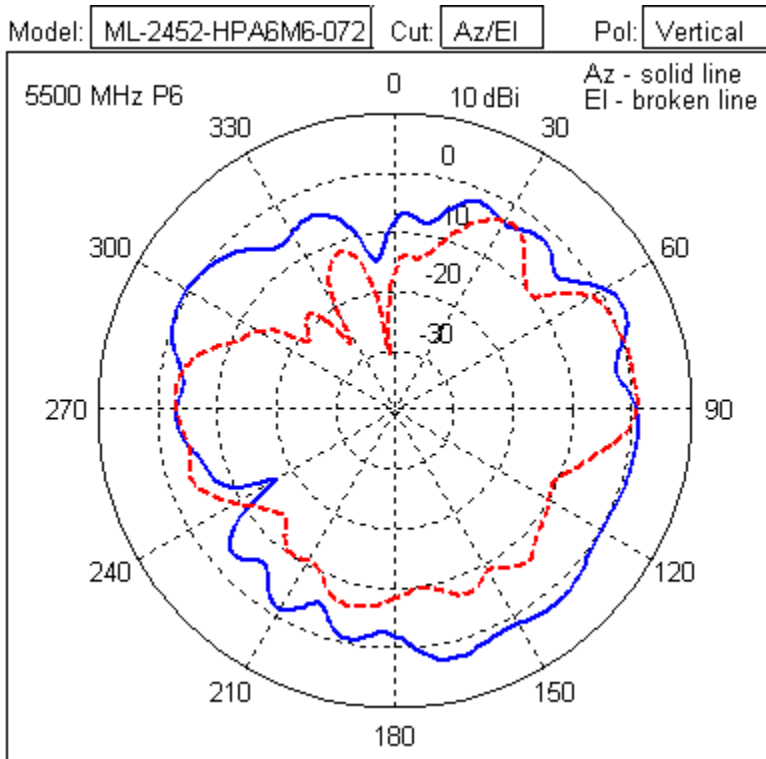
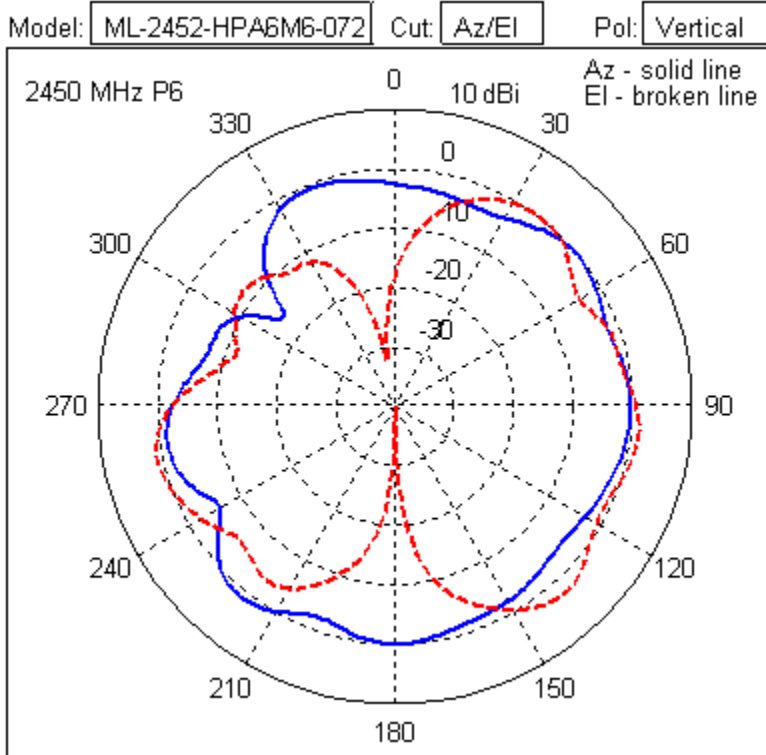

ML-2452-VMM3M3-036 11ABGN, 3-Port Omni Array, RP-SMA Male x 3

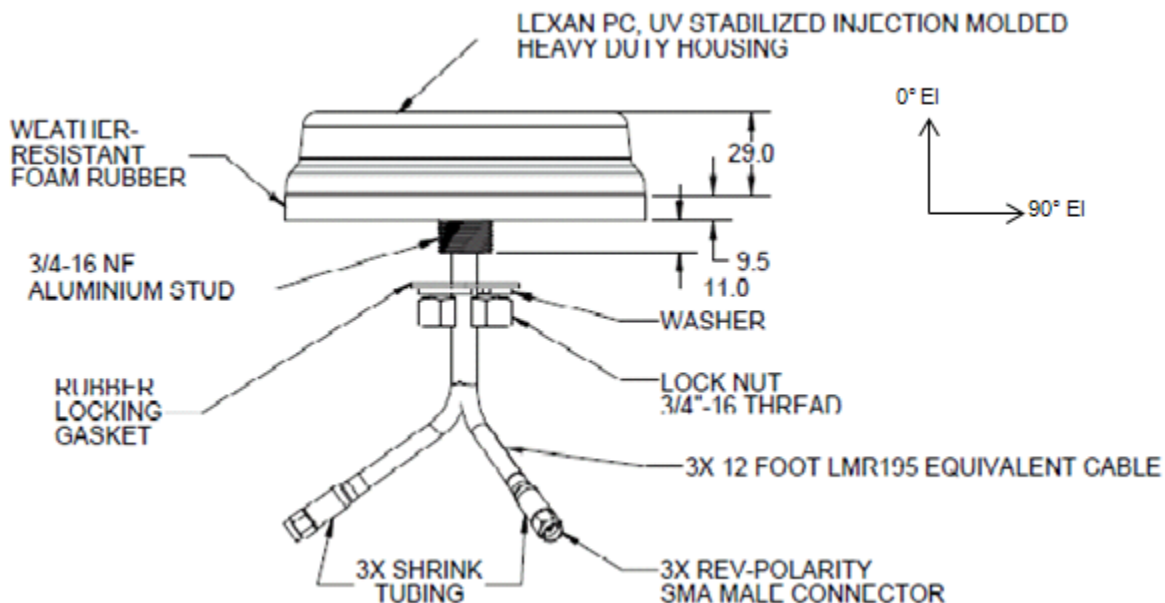

Type	Dipole
Description	3-Port Omni Array, RP-SMA Male x 3
Frequency	2400-2500/4900-5875 MHz
Max Gain (dBi)	4.5/5.4
Polarization	Linear, Vertical
Azimuth	3 dB Beamwidth: 360 degrees (2.4 GHz) 3 dB Beamwidth: 360 degrees (5 GHz)
Elevation	3 dB Beamwidth: 40 degrees (2.4 GHz) 3 dB Beamwidth: 30 degrees (5 GHz)
Cable Length (inches)	144+/-2.8
Cable Type	LMR195 equiv
Connector Type	RP-SMA Male x 3
Antenna Plenum Rated	N/A
Cable Plenum Rated	No
Outdoor Rated	Yes
Weight	1.34 lbs
Storage Temp Range (C)	-35/ +80
Operation Temp Range (C)	-30/ +80

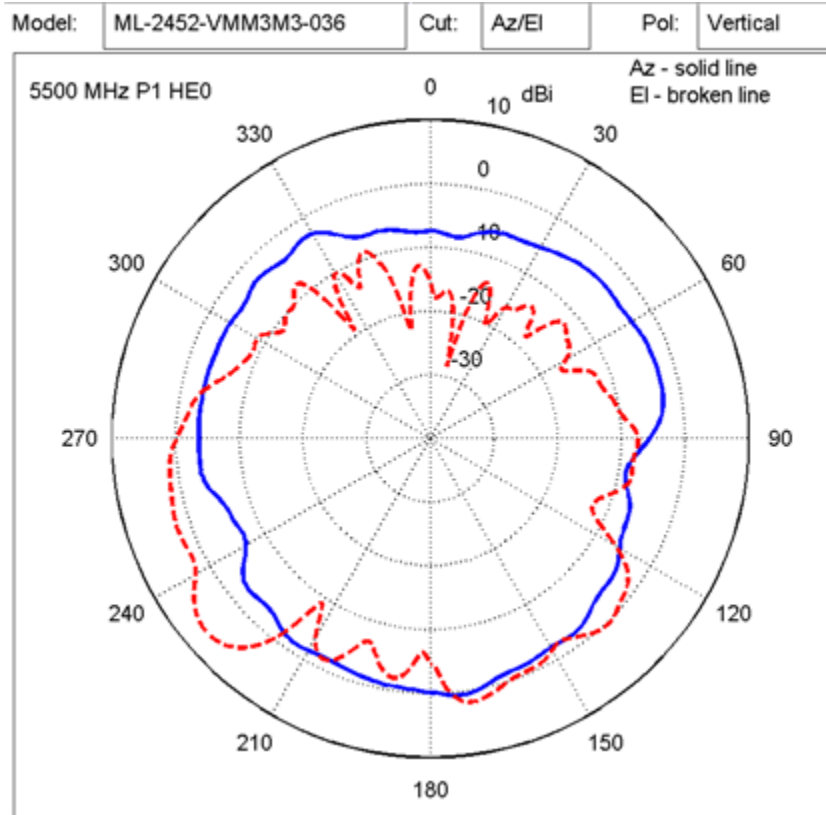
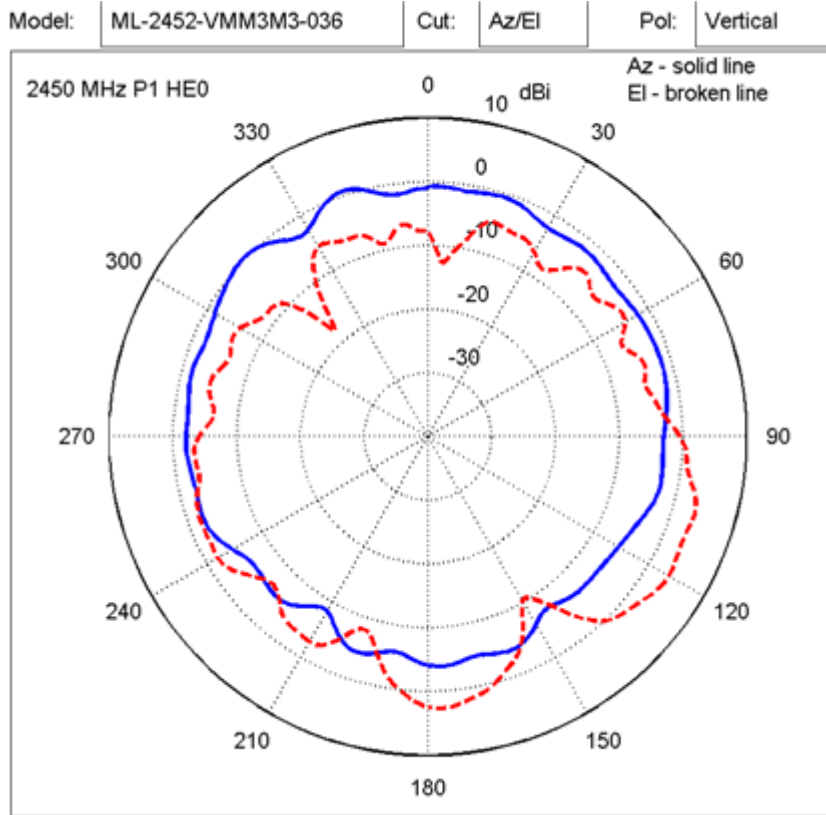

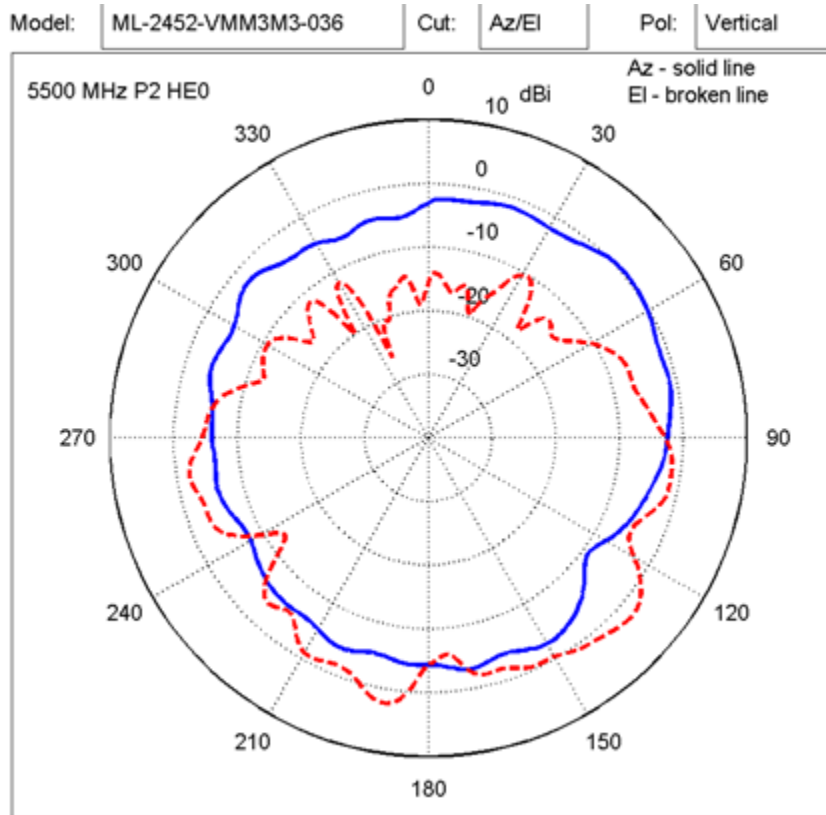
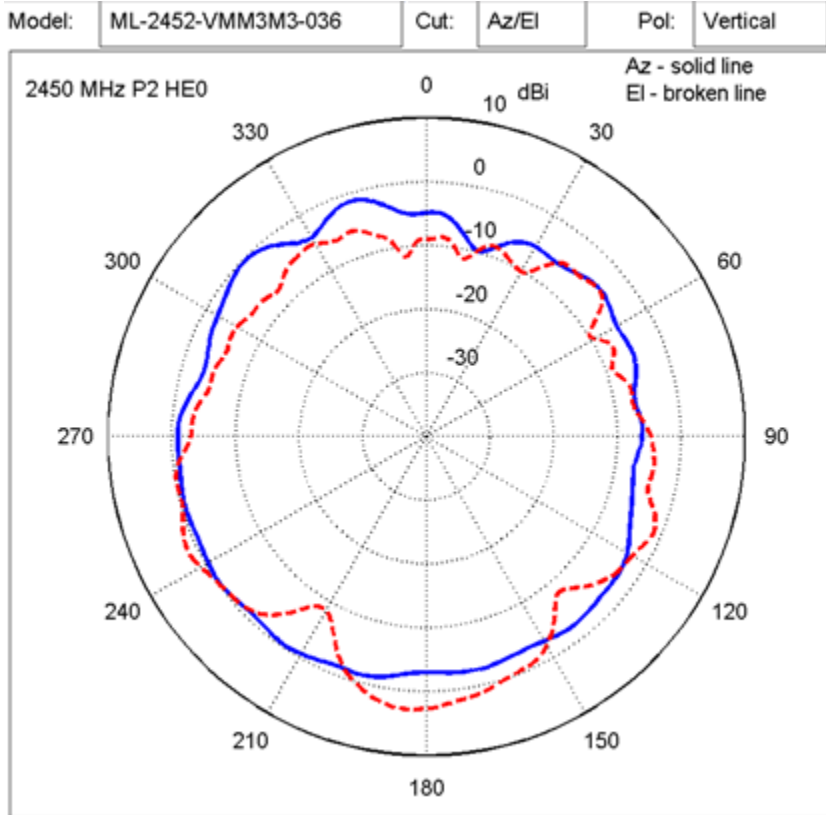

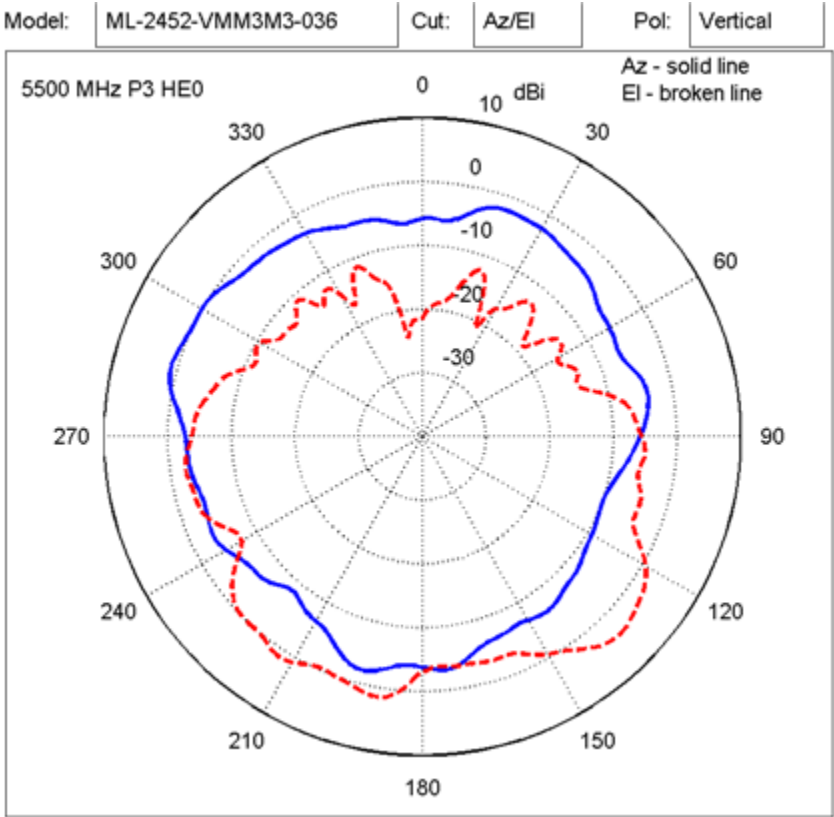
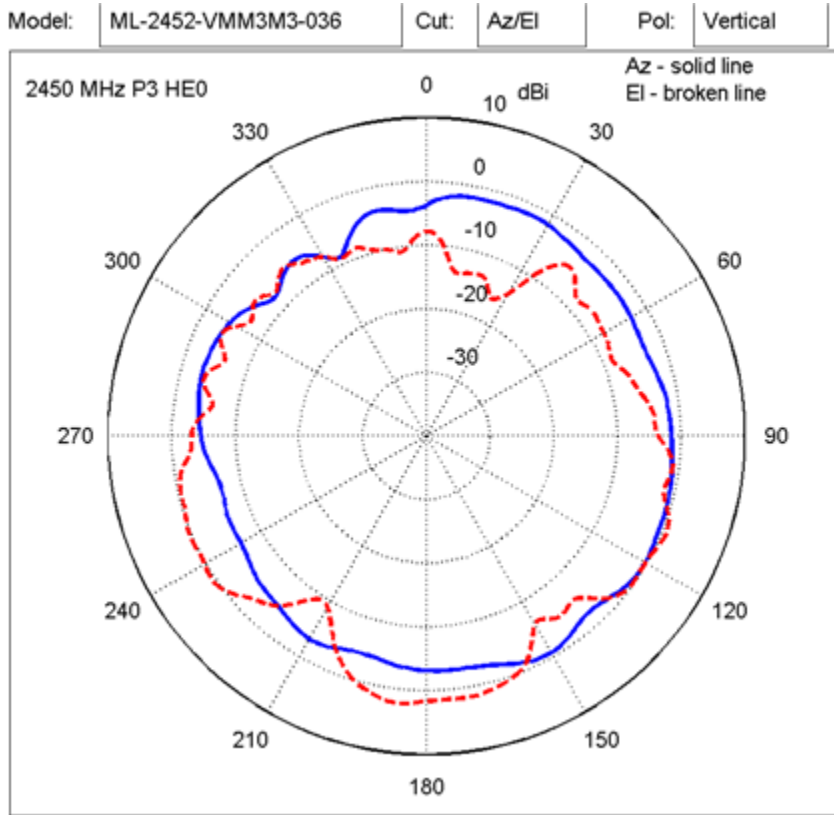

AP6562 Internal 802.11ABGN, Multi-Element x 2



Type	AP6562 Internal- Multi-element x 2 Single-band element - 2.4 GHz Dual-band element - 2.4/ 5GHz
Frequency	2412-2485, 5150-5850 MHz
Max Gain (dBi)	7.0/8.0
Polarization	Linear, Linear
Azimuth	3 dB Beamwidth: 120 degrees (5 GHz), 90 degrees (2.4 GHz)
Elevation	3 dB Beamwidth: 90 degrees (5 GHz), 90 degrees (2.4 GHz)
Cable Length (centimeters)	N/A
Cable Type	1.37 mm coax
Connector Type	U.FI x 4
Antenna Plenum Rated	N/A
Cable Plenum Rated	Yes
Outdoor Rated	Yes
Weight	< 4 oz.
Storage Temp Range (C)	-40 / +85
Operational Temp Range (C)	-30 / +60

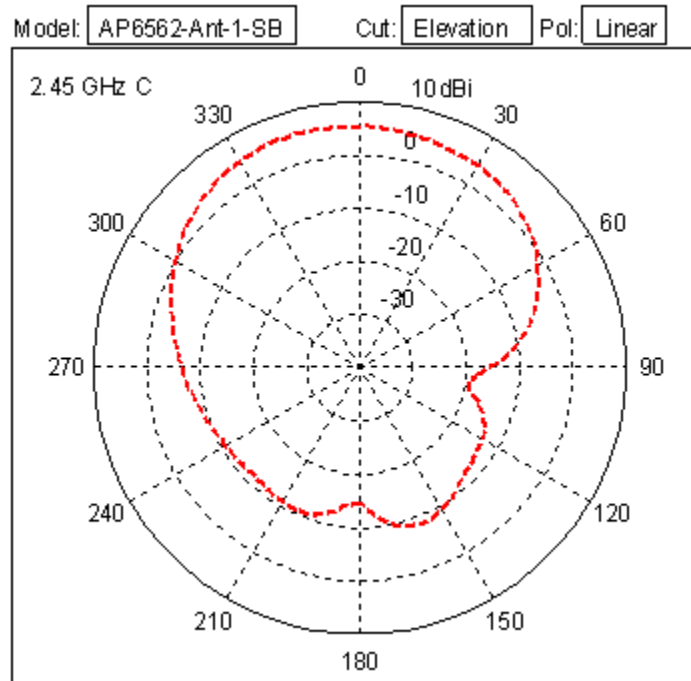
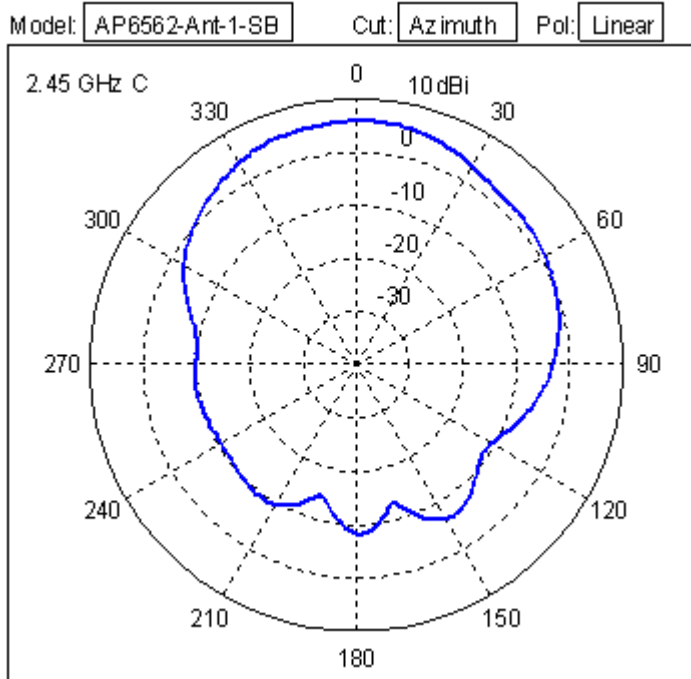

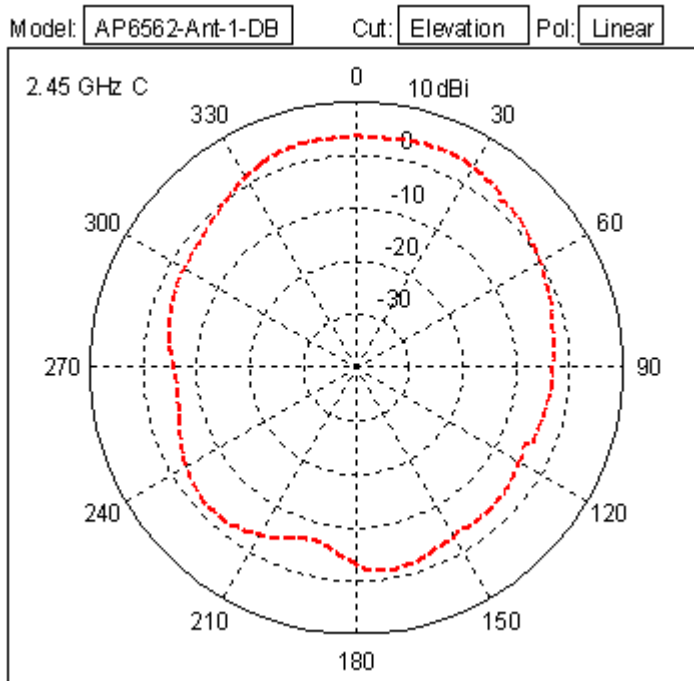
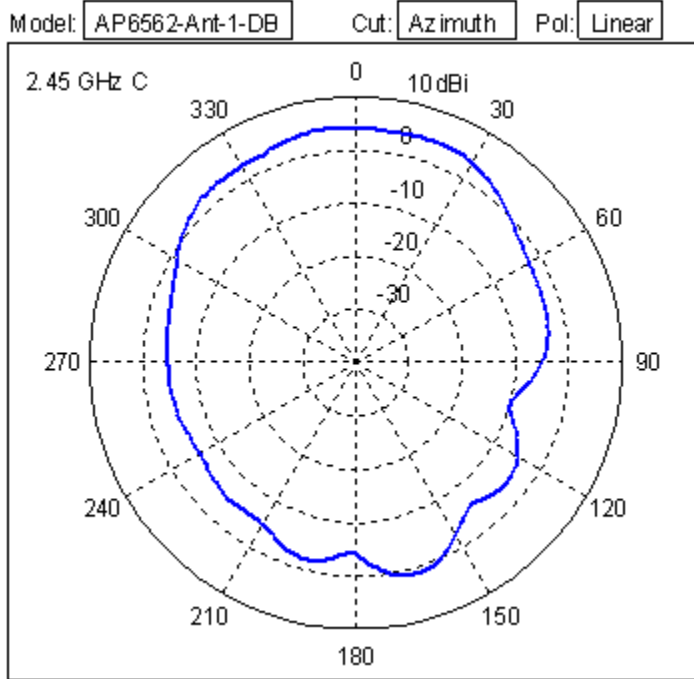

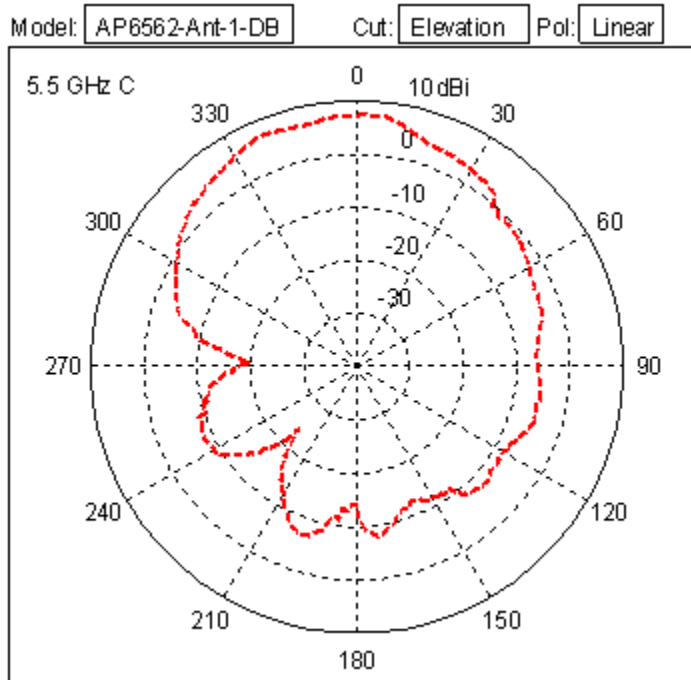
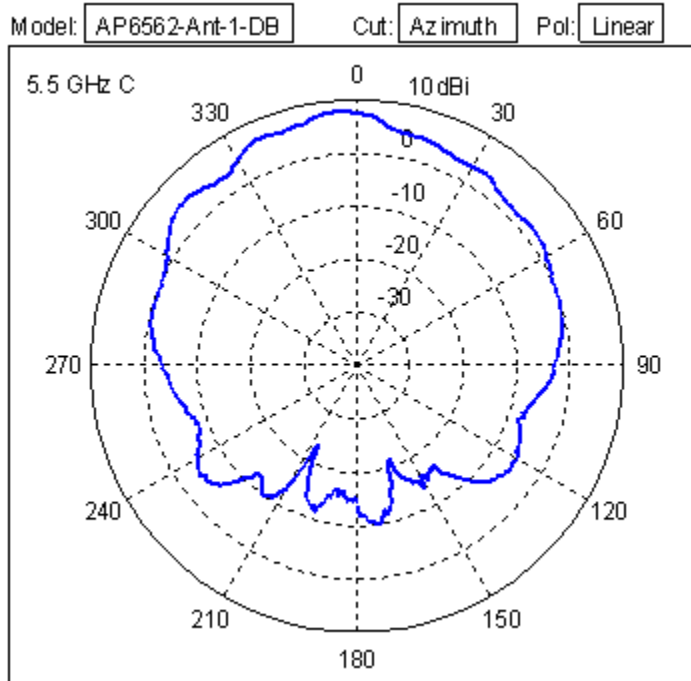

AP8222 Internal 802.11ABGN, 6 x PIFA, -1.8 dBi, LP, U.FI

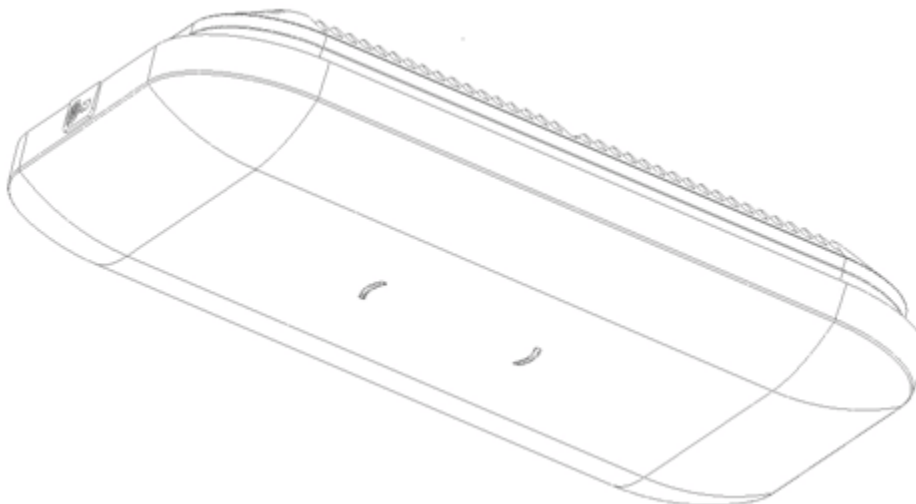

Type	AP8222 Internal - Antennas 1, 2, 3 (3-Element PIFA Array, 5 GHz only)
Frequency	4900-5900 MHz
Max Gain (dBi)	5.3/-1.8
Polarization	Linear, Vertical
Azimuth	3 dB Beamwidth: 360 degrees (5 GHz)
Elevation	3 dB Beamwidth: 180 degrees (5 GHz)
Cable Length (centimeters)	18
Cable Type	N/A
Connector Type	U.FI x 3
Antenna Plenum Rated	N/A
Cable Plenum Rated	No
Outdoor Rated	No
Weight	TBD
Storage Temp Range (C)	-40/ +70
Operation Temp Range (C)	-20/ +70

Type	AP8222 Internal - Antennas 4, 5, 6 (3-Element PIFA Array, 2.4 & 5 GHz)
Frequency	2400-2500/4900-5900 MHz
Max Gain (dBi)	4.3/-1.8 (2 GHz), 4.7/-1.8 (5 GHz)
Polarization	Linear, Vertical
Azimuth	3 dB Beamwidth: 360 degrees (2.4 GHz) 3 dB Beamwidth: 360 degrees (5 GHz)

Elevation	3 dB Beamwidth: 160 degrees (2.4 GHz) 3 dB Beamwidth: 160 degrees (5 GHz)
Cable Length (centimeters)	18
Cable Type	N/A
Connector Type	U.FI x 3
Antenna Plenum Rated	N/A
Cable Plenum Rated	No
Outdoor Rated	No
Weight	TBD
Storage Temp Range (C)	-40/ +70
Operation Temp Range (C)	-20/ +70

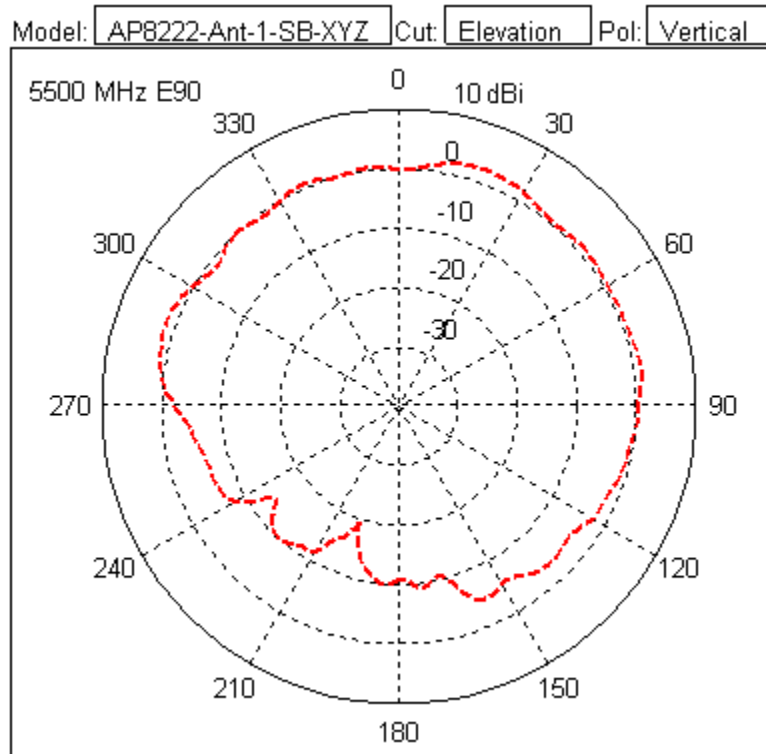
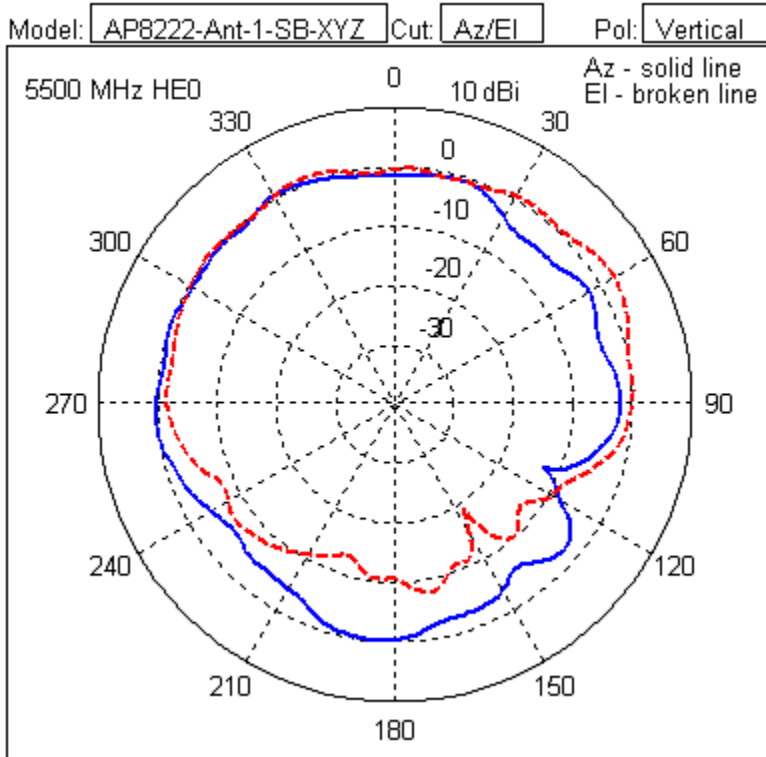

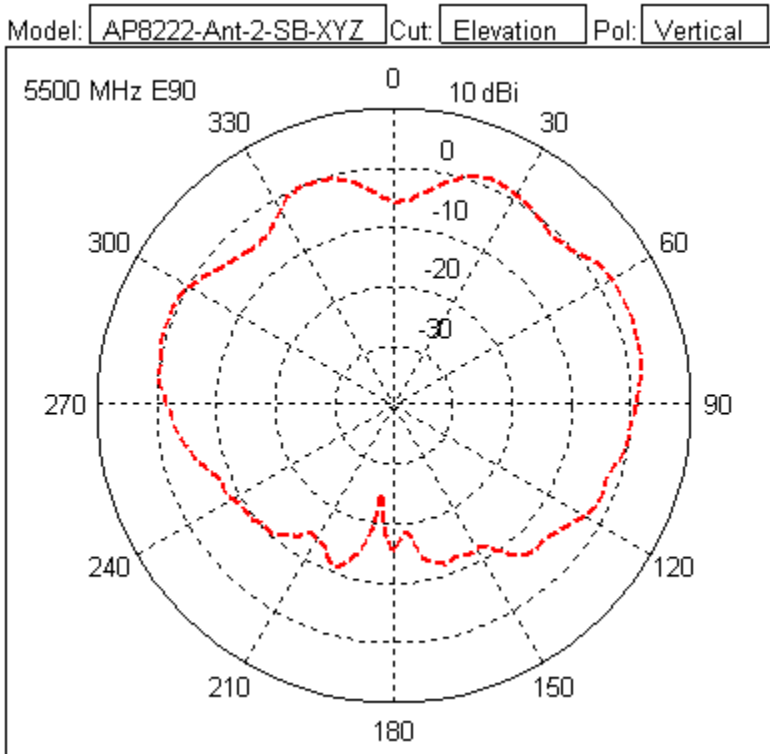
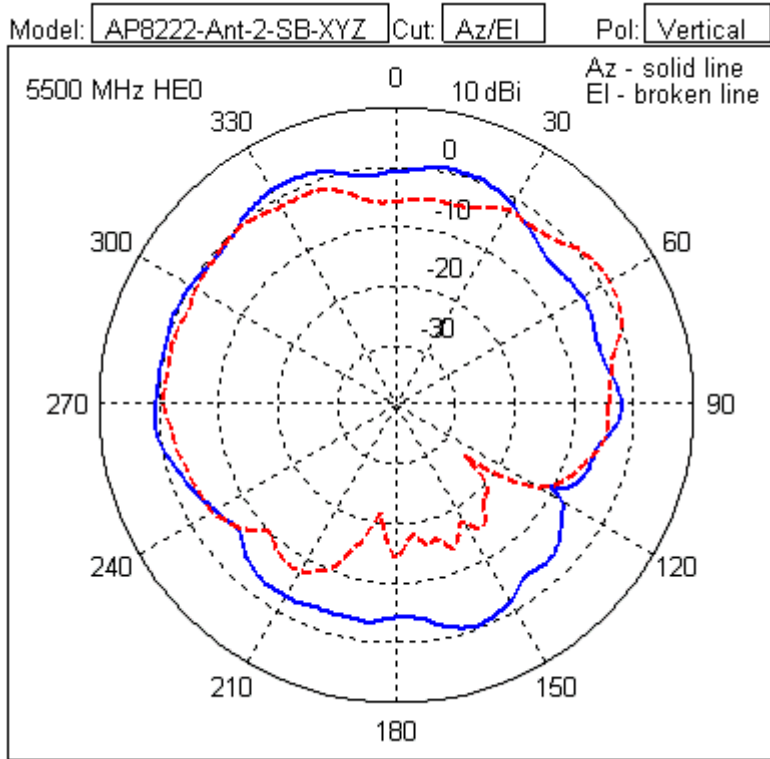

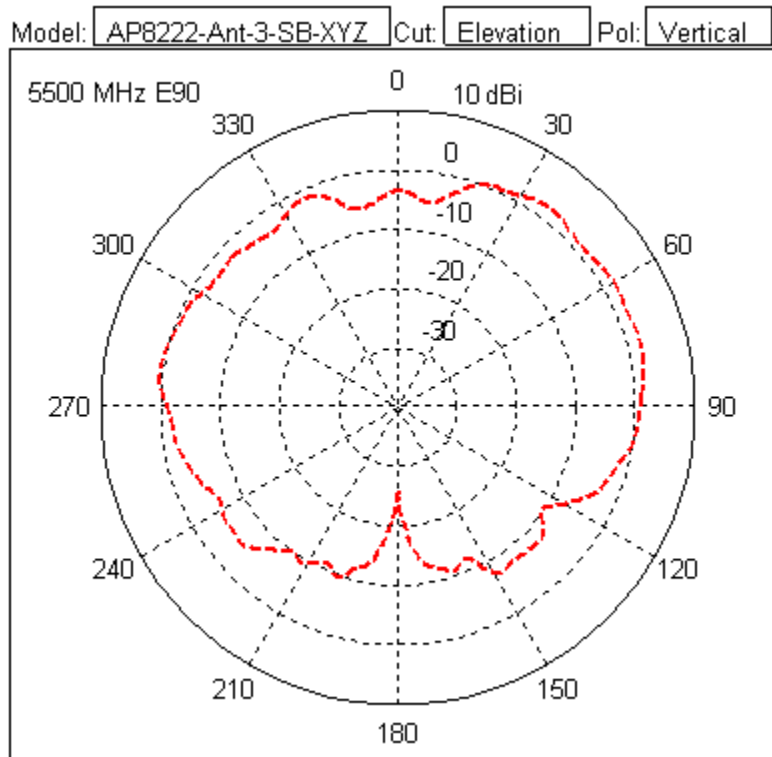
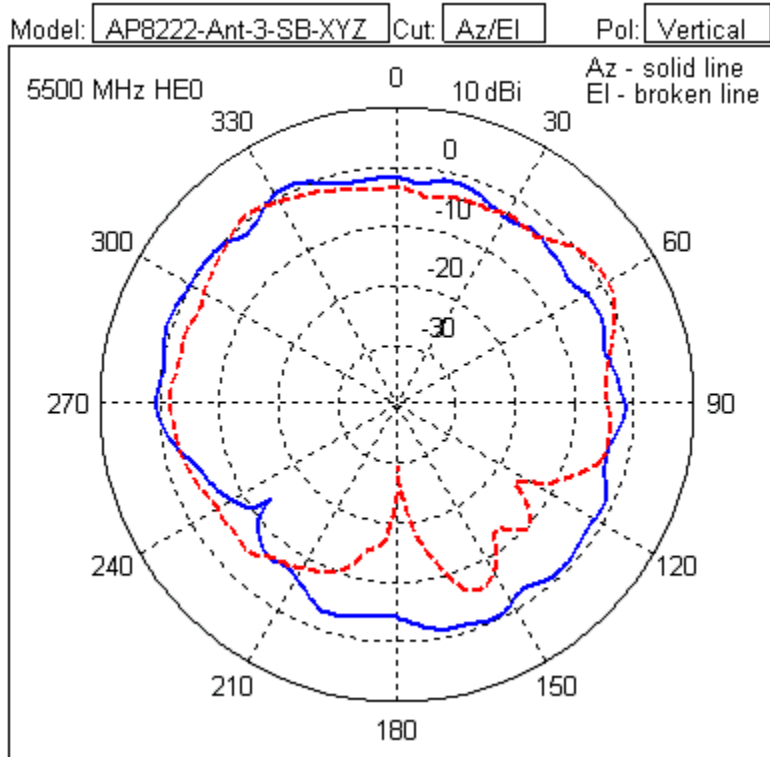

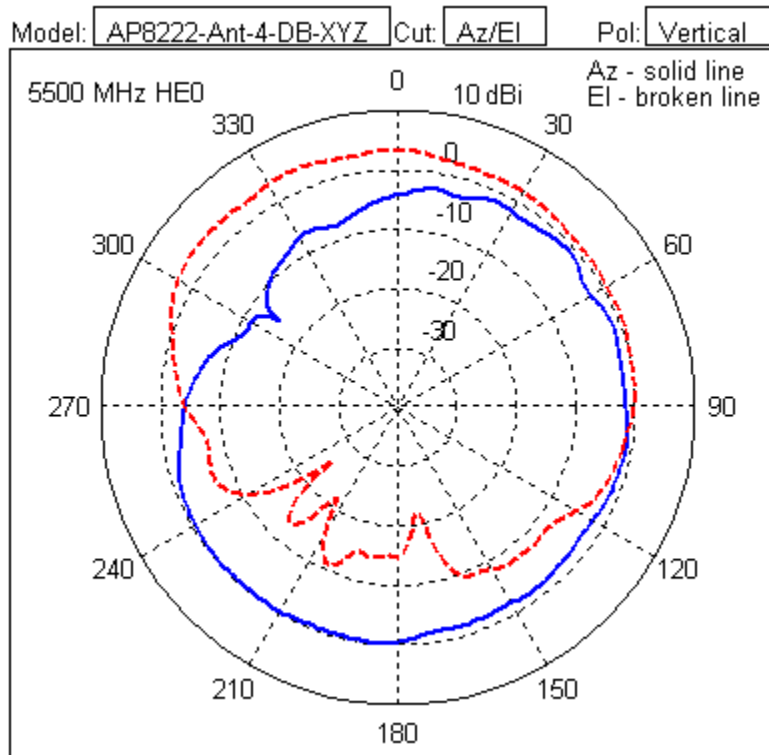
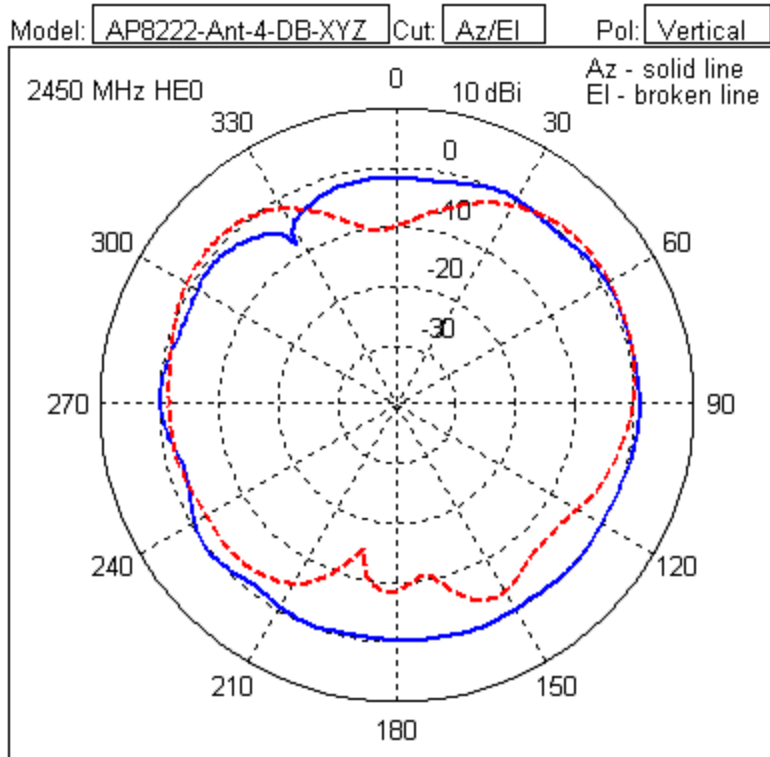

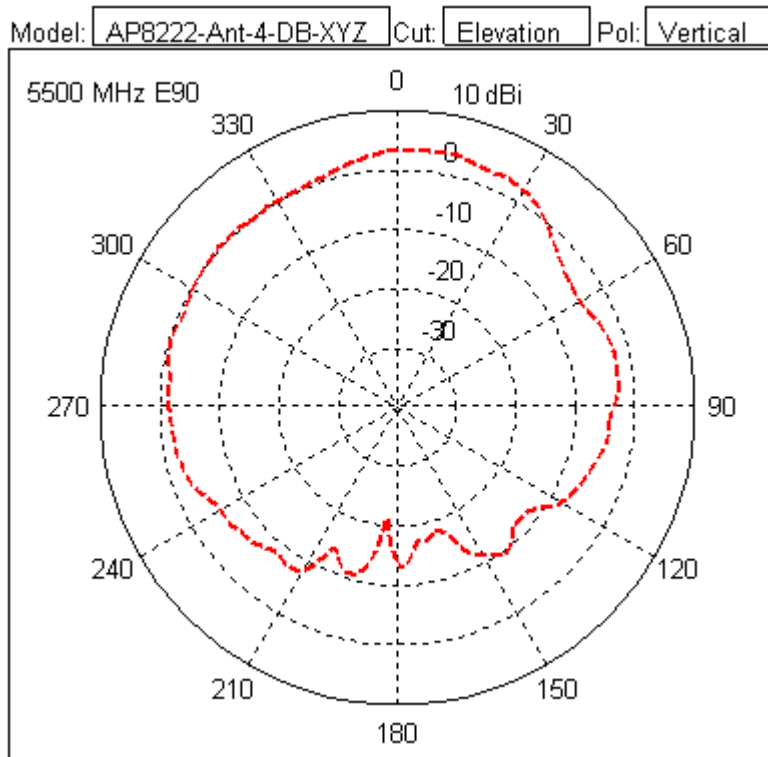
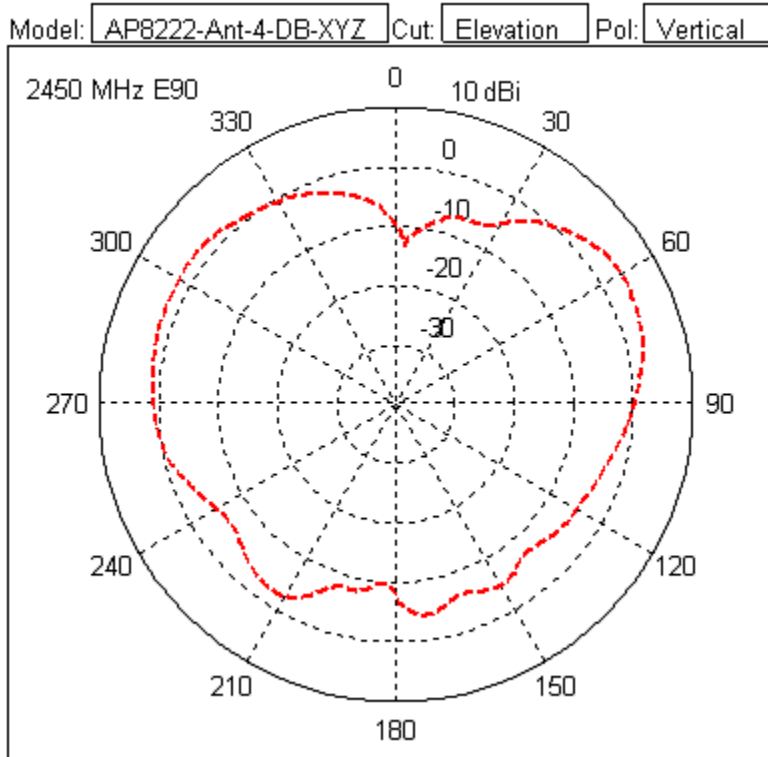

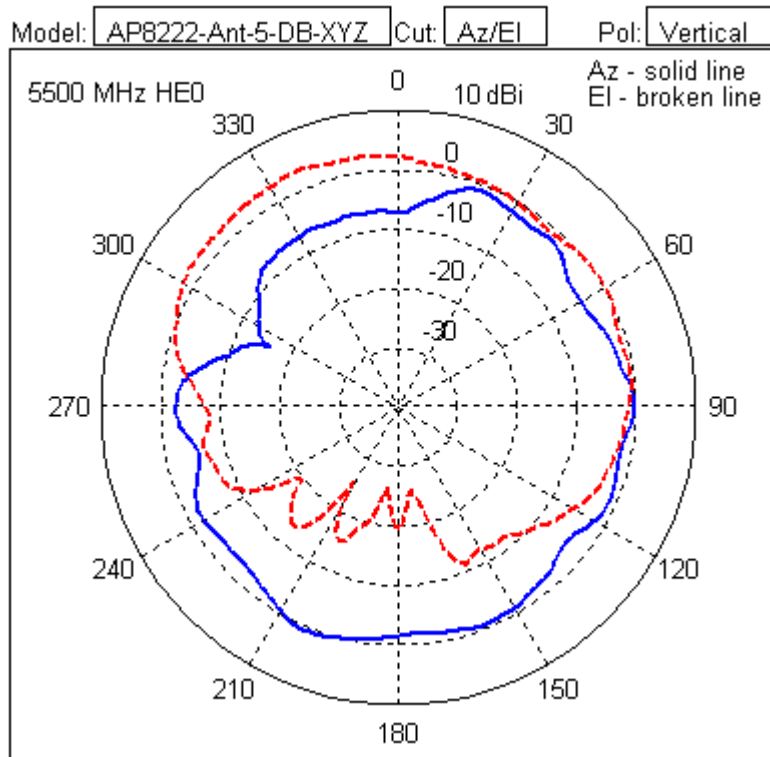
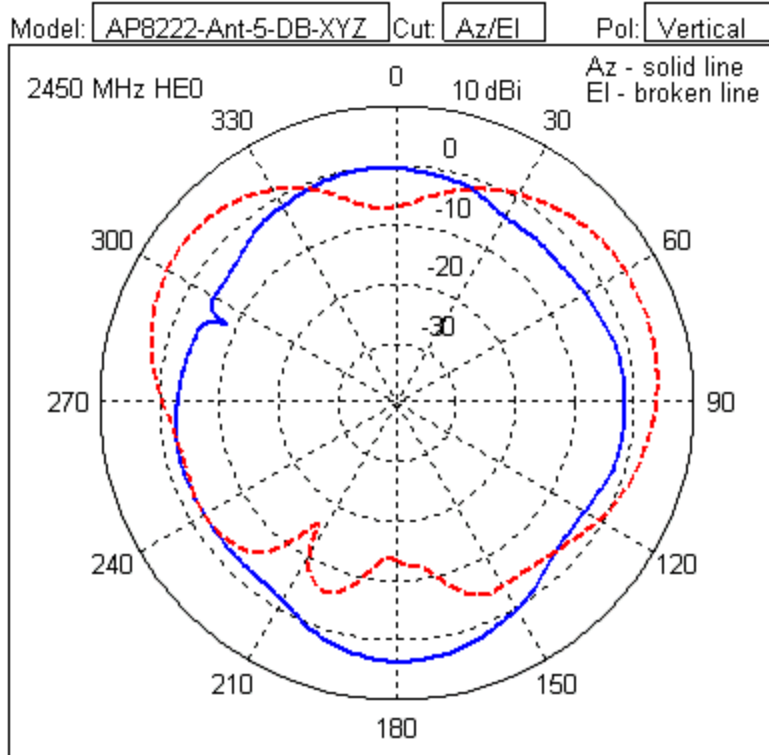

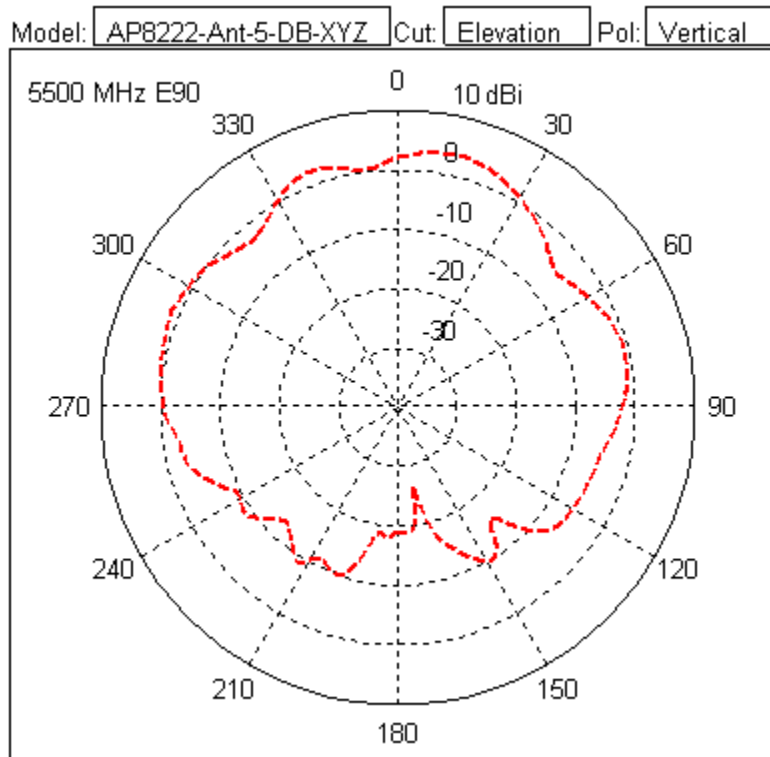
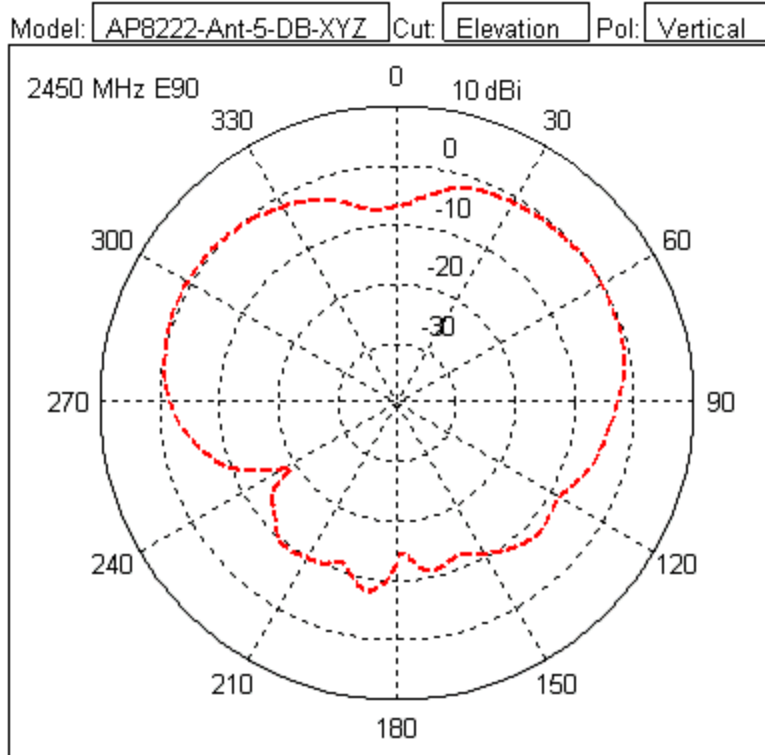

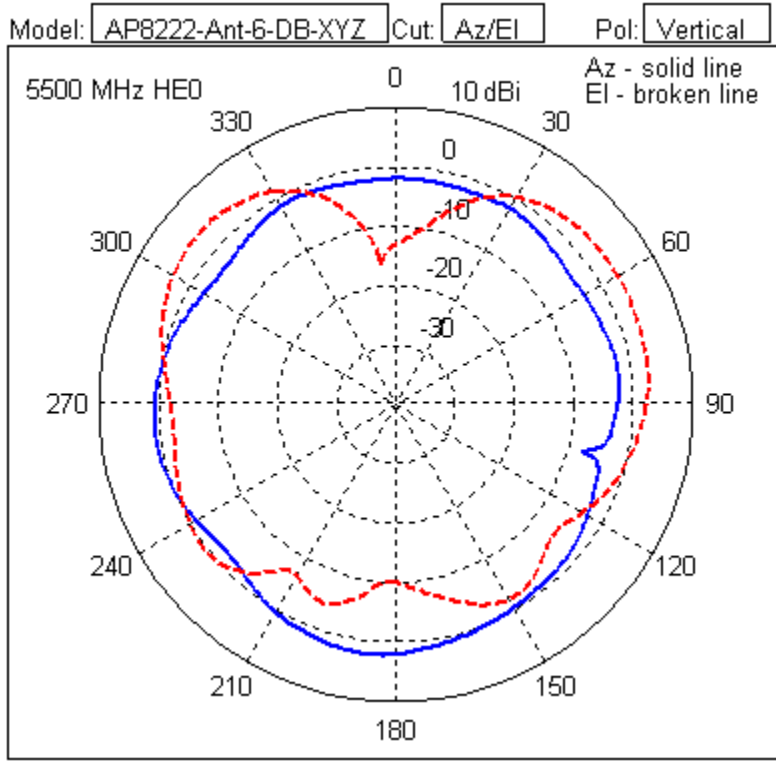
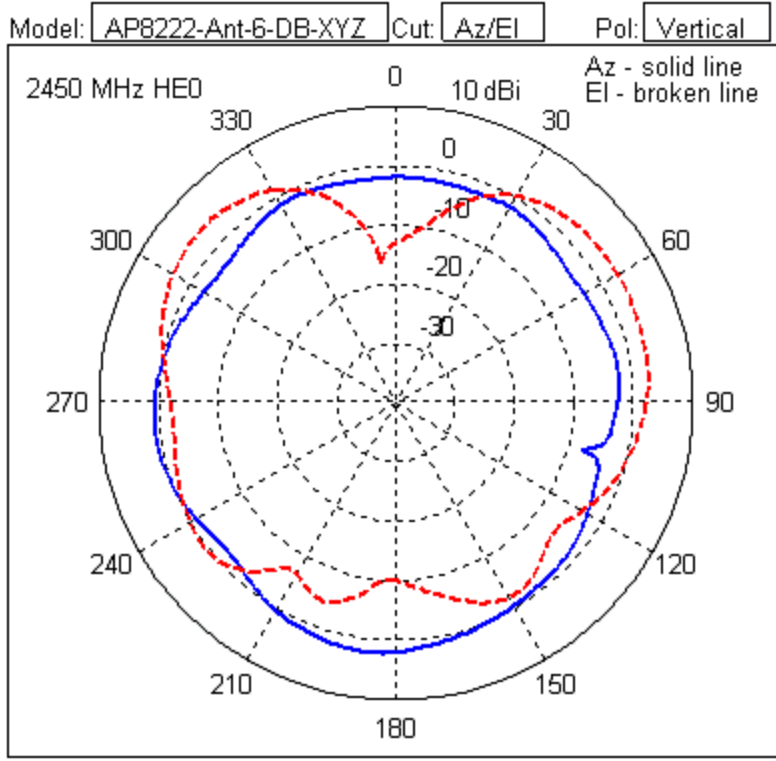

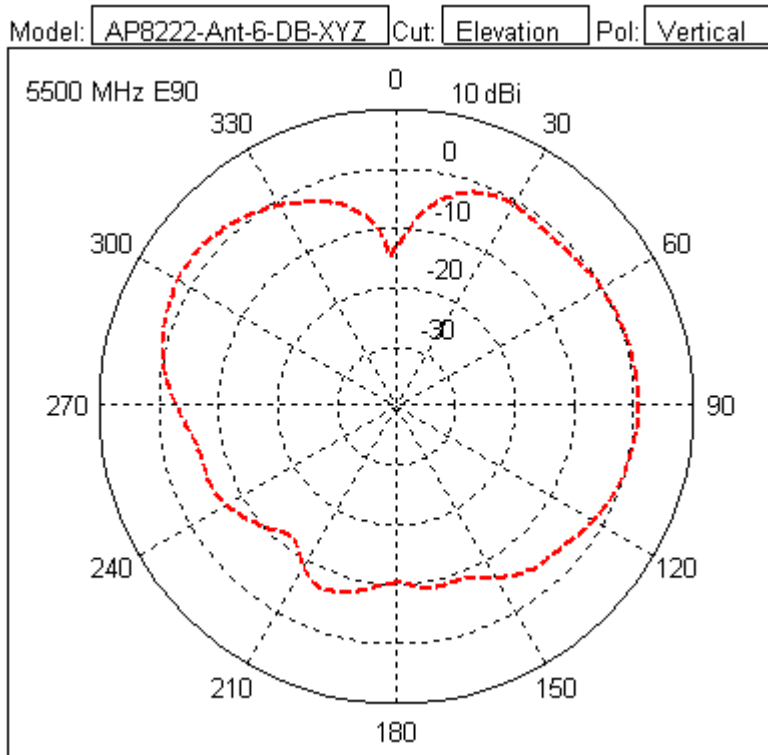
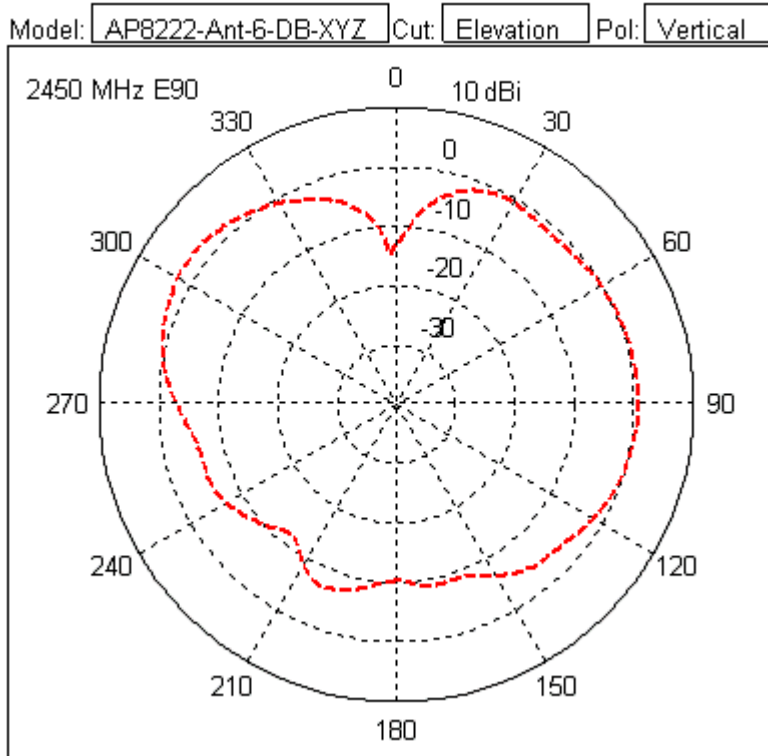

AP-7522 and AP-7532 Dual-Band Monopole (2.4/5 Ghz)

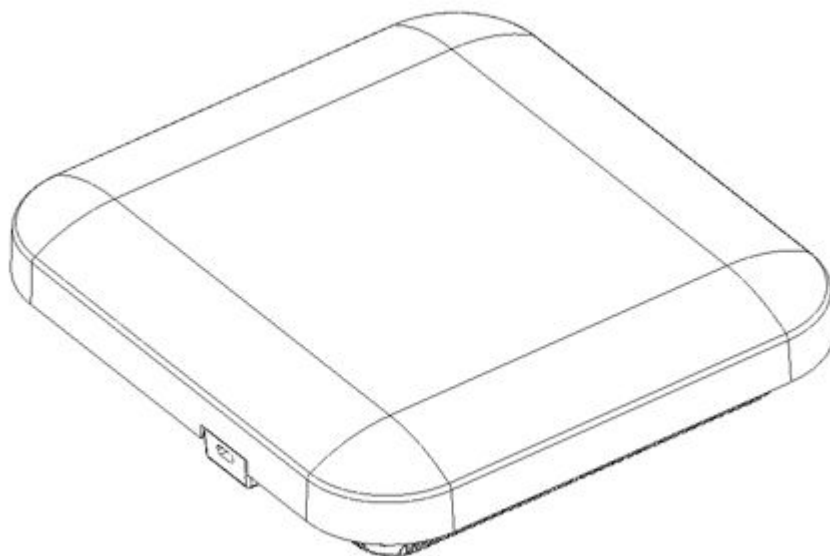

Type	AP-7522 and AP-7532 Dual-Band Monopole (2.4/5 Ghz)
Frequency	2400-2500, 5000-6000 MHz
Max Gain (dBi)	4.13/5.92
Polarization	Linear, Vertical
Azimuth	360 degrees
Elevation	160 degrees
Cable Length (centimeters)	N/A
Cable Type	N/A
Connector Type	U.FI
Antenna Plenum Rated	N/A
Cable Plenum Rated	N/A
Outdoor Rated	No
Weight	N/A
Storage Temp Range (C)	-40 / +70
Operation Temp Range (C)	-20 / +70

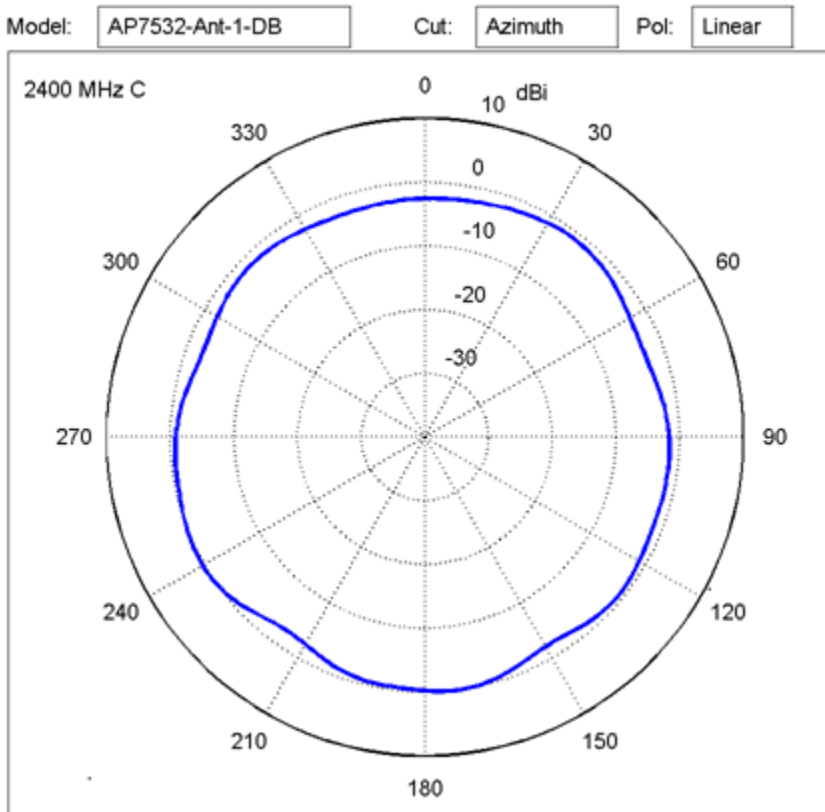
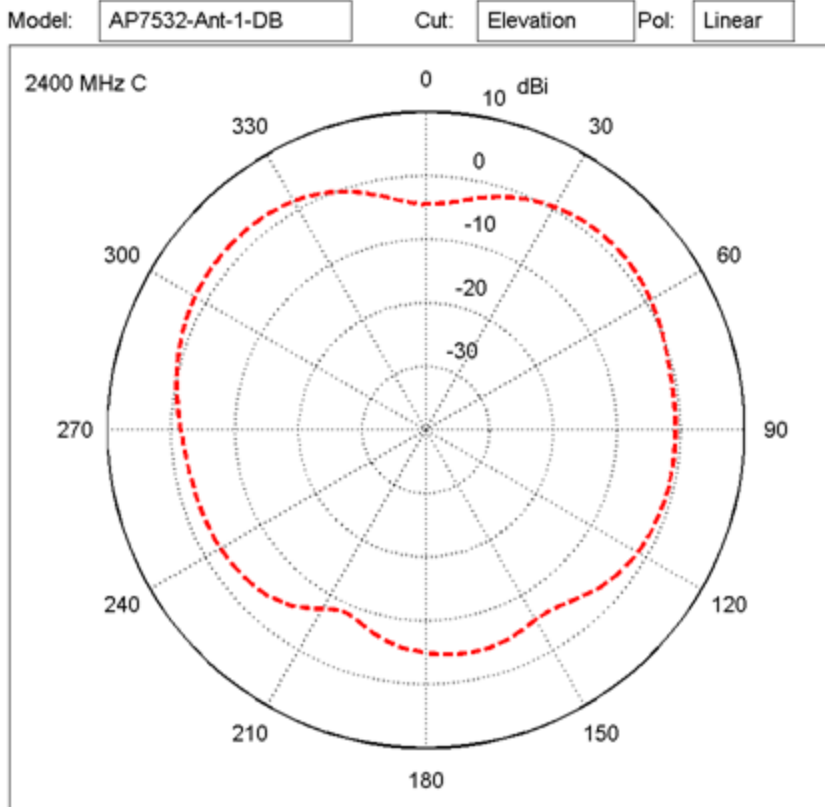

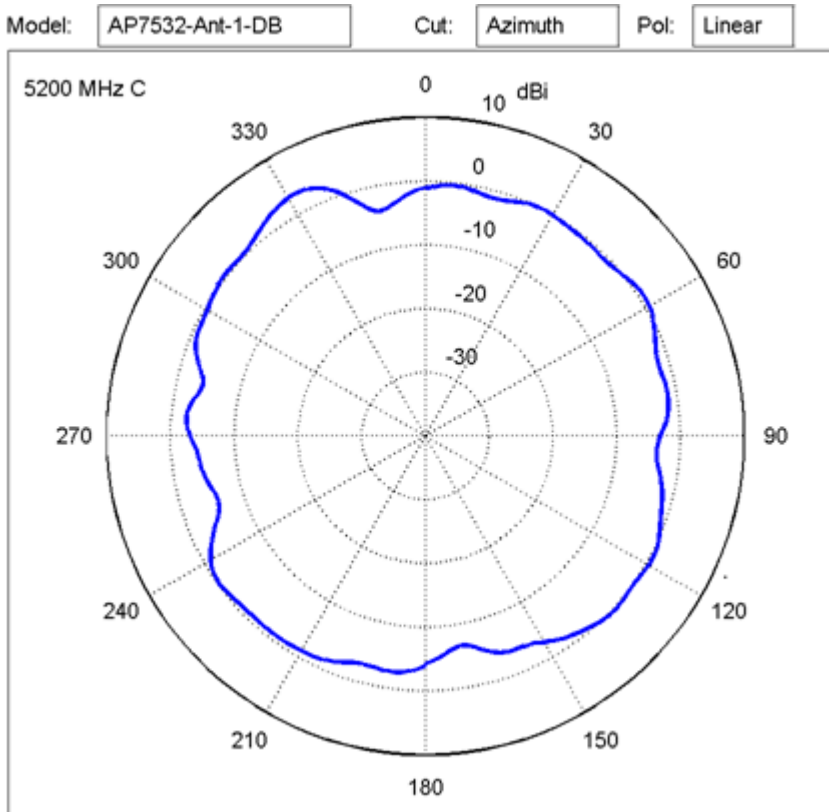
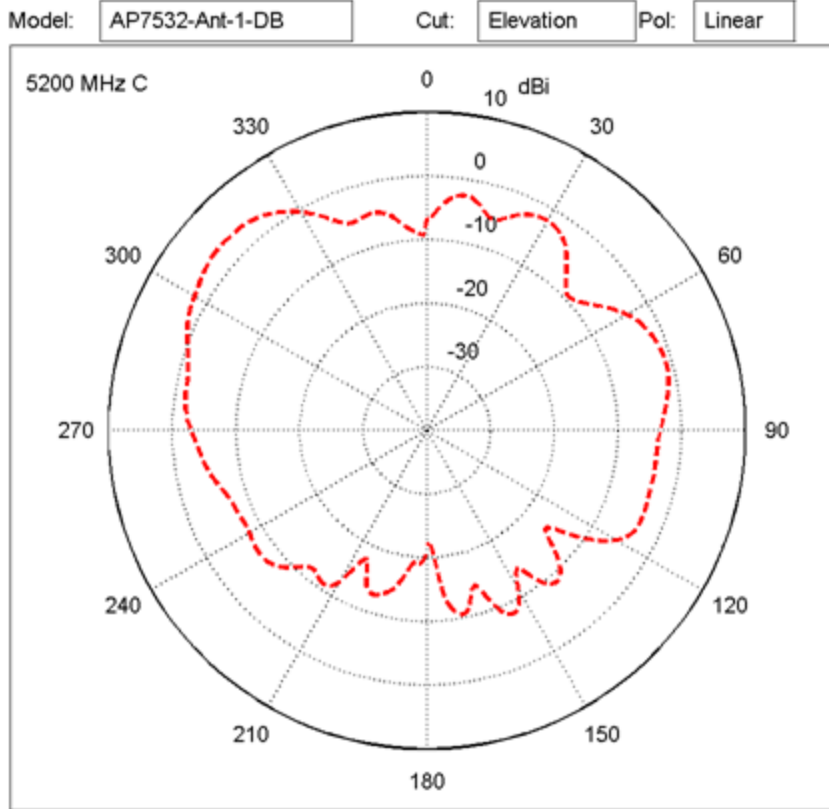

ML-2452-PNL3M3-1 11ABGN, 3-Port Polarized Panel, 9.7/9.2 dBi, DP, Fixed N-Type Female

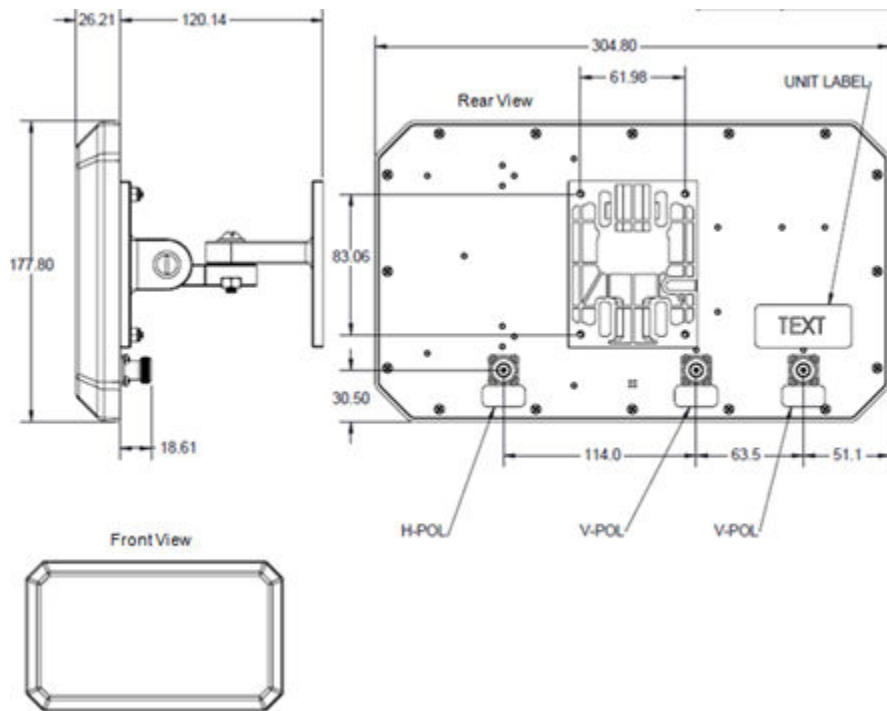

Type	Polarized Panel
Frequency	2400-2500, 4900-5900
Max Gain (dBi)	9.7/9.2
Polarization	Linear, Vertical
Azimuth	90/120 degrees
Elevation	45/30 degrees
Cable Length (centimeters)	N/A
Cable Type	N/A
Connector Type	Fixed N-Type Female x 3
Antenna Plenum Rated	No
Cable Plenum Rated	N/A
Outdoor Rated	Yes
Weight	1.5 lbs
Storage Temp Range (C)	-40/+85
Operation Temp Range (C)	-30 / +70

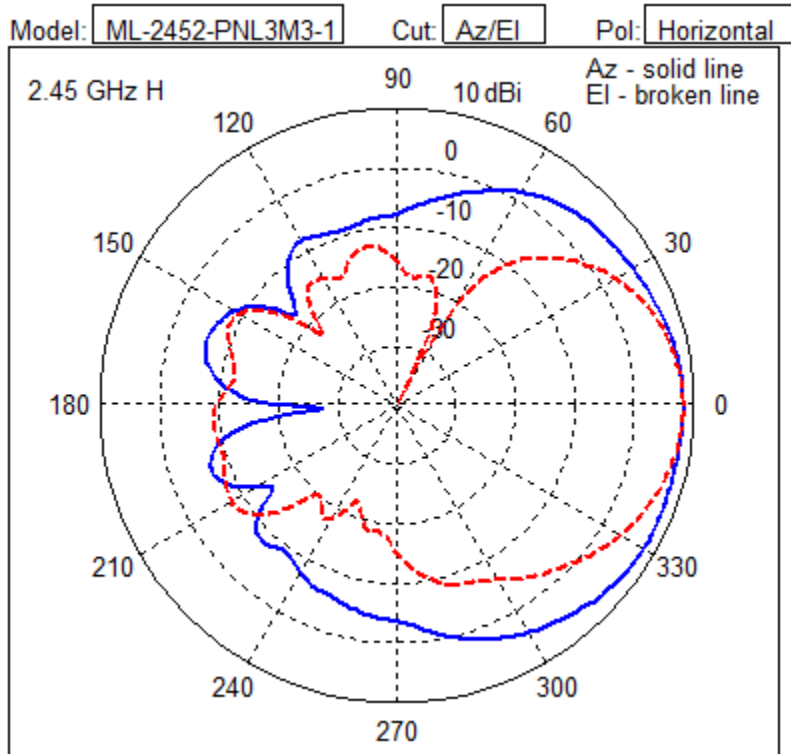
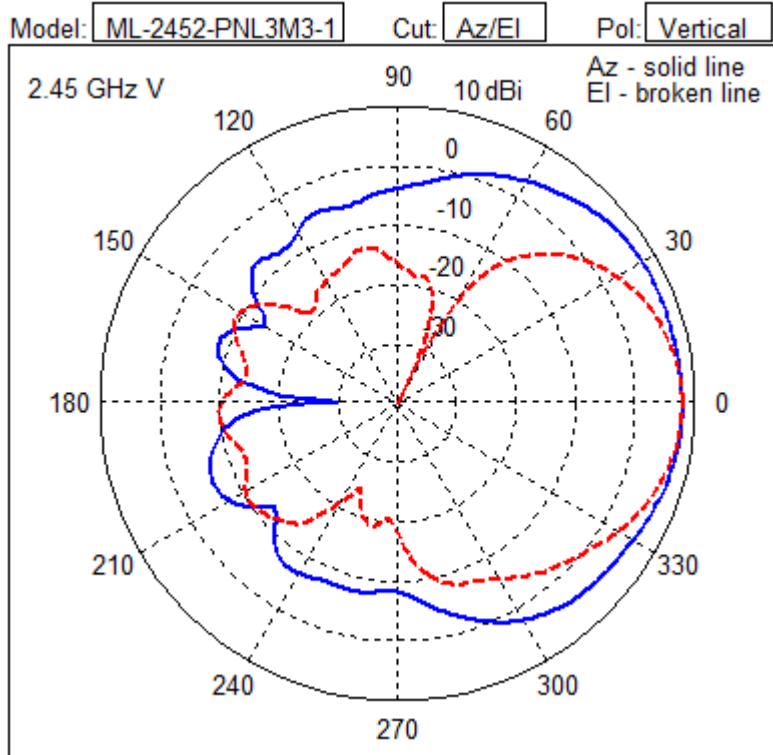

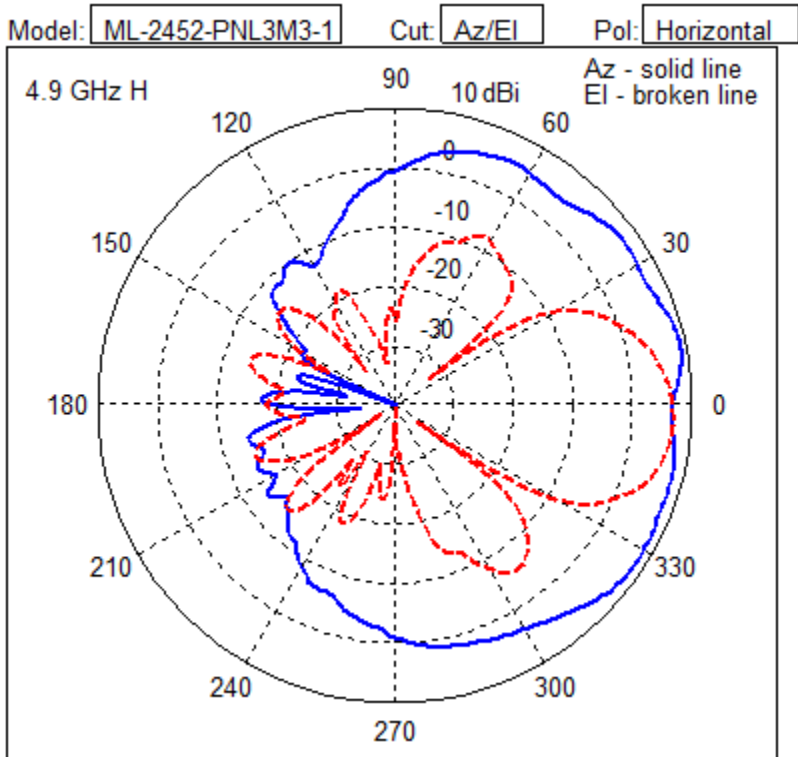
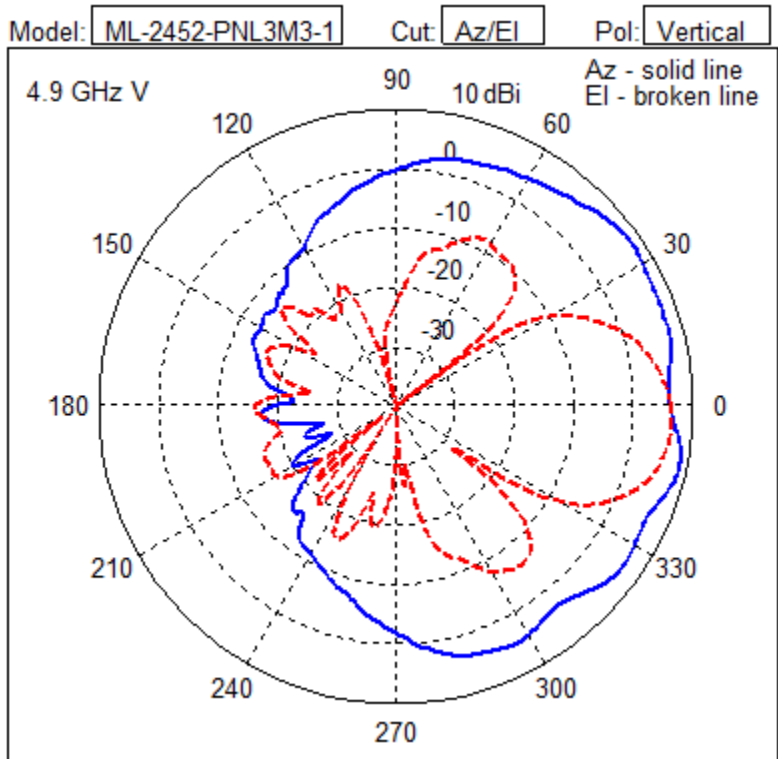

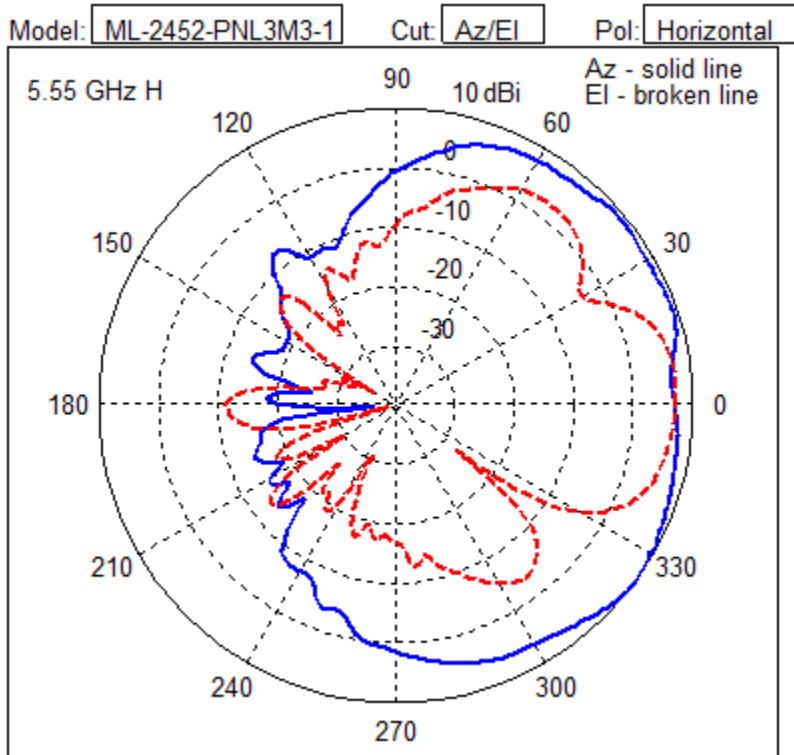
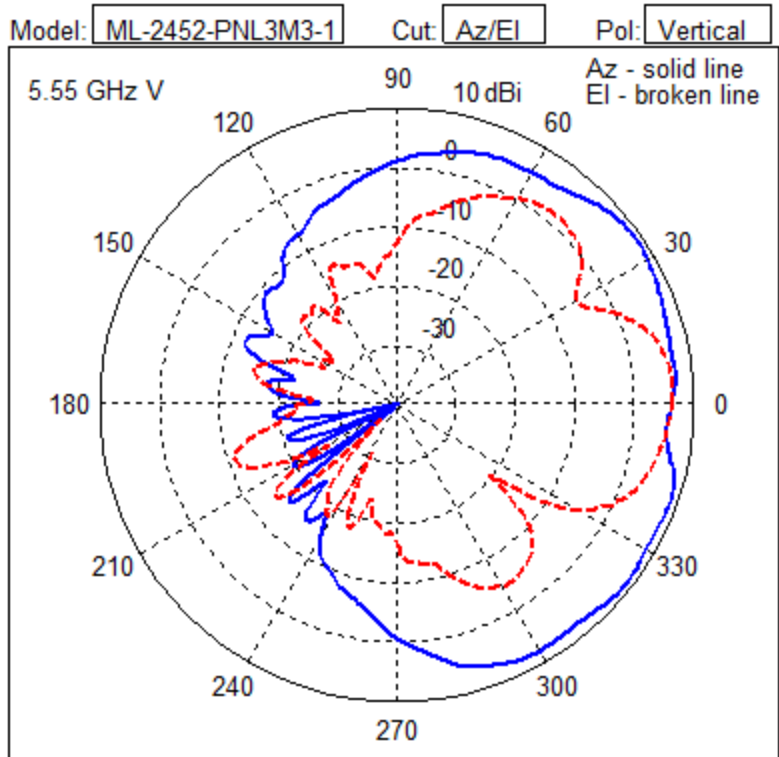

ML-2452-HPA6-01, 11ABGN, Dipole, N-Type Male

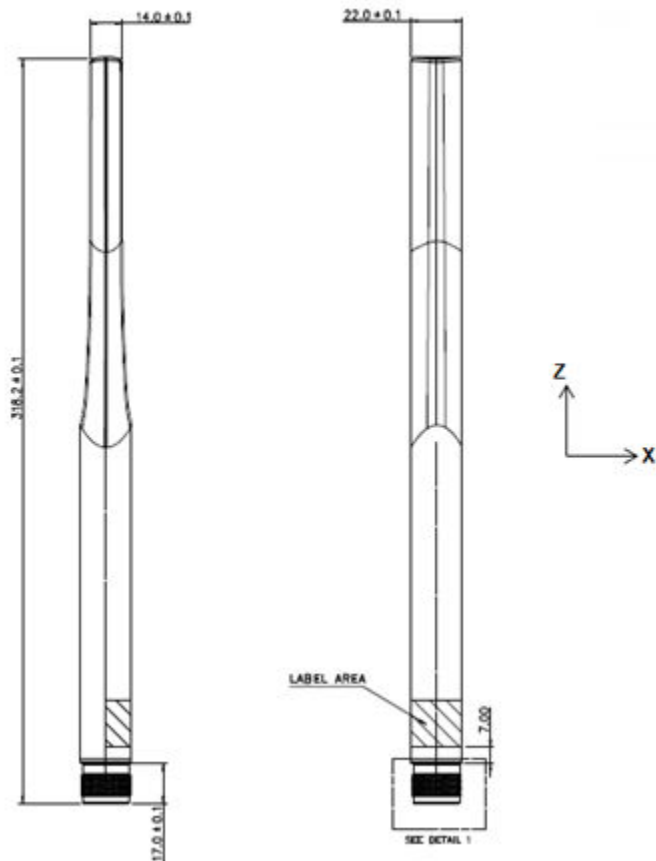

Type	Dipole
Frequency	2400-2500, 4950-4990, 5150-5875
Max Gain (dBi)	5.3/4.6/6.1
Elevation Gain (dBi)	4.1
Polarization	Linear, Vertical
Azimuth	360 degrees
Elevation	30 degrees
Cable Length (centimeters)	N/A
Cable Type	N/A
Connector Type	N-Type Male
Antenna Plenum Rated	N/A
Cable Plenum Rated	N/A
Outdoor Rated	Yes
Weight (lbs)	0.25
Storage Temp Range (C)	-40/+85
Operation Temp Range (C)	-40/+85

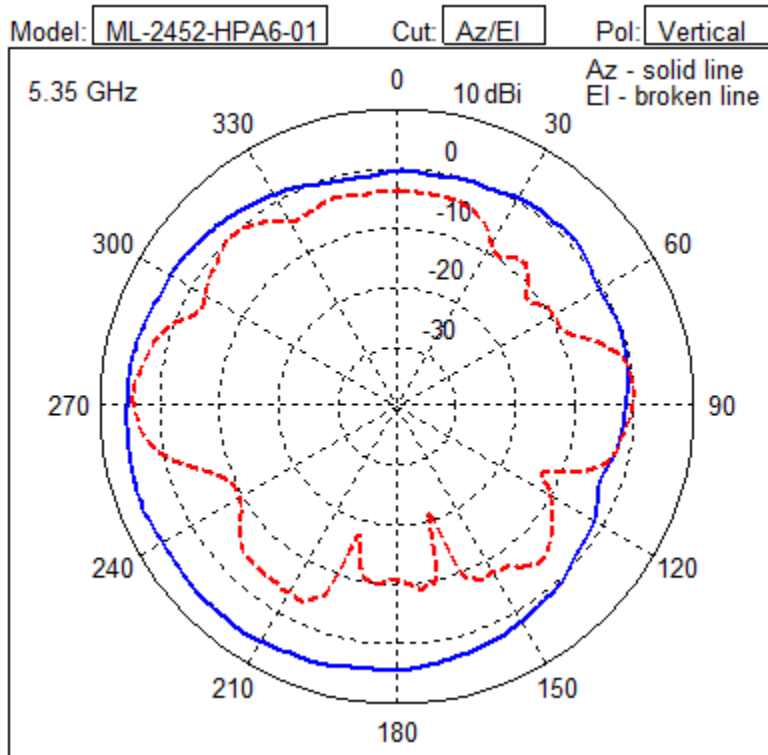
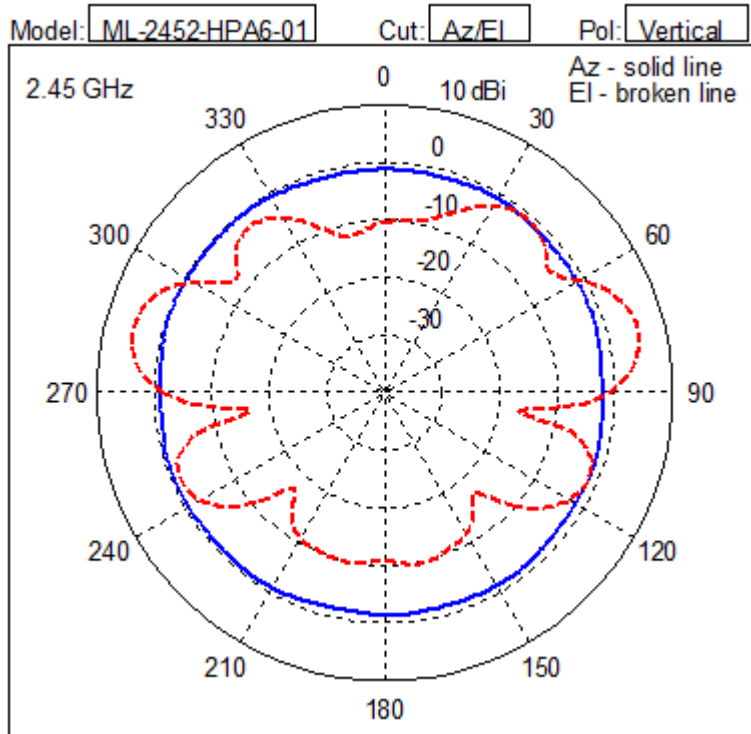

AP7502 Internal 802.11ABGNac, Dipole Omni x4

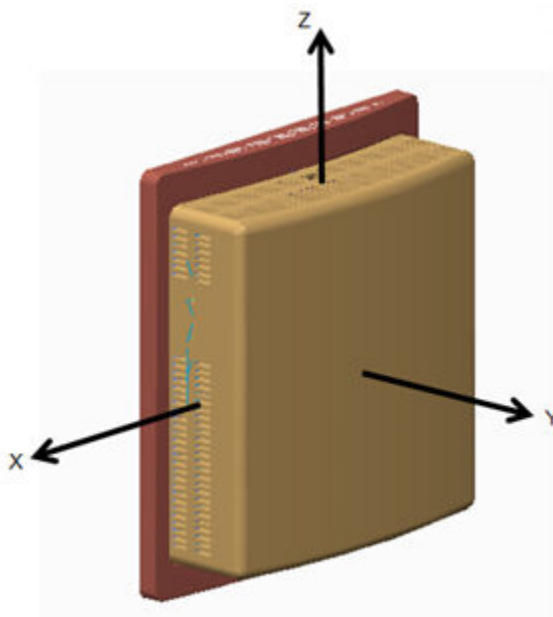

Type	AP7502 Internal- Dipole Omni x4 2.4 GHz Dipole x 2 5GHz Dipole x2
Frequency	2400-2500, 5150-5850 MHz
Max Gain (dBi)	5.8, 7.3 (2.4GHz/5GHz)
Polarization	Linear, Vertical
Azimuth 3 dB Beamwidth:	120°/90° (2.4GHz/5GHz)
Elevation 3 dB Beamwidth:	90°/90° (2.4GHz/5GHz)
Cable Length (centimeters)	N/A
Cable Type	1.37 mm coax
Connector Type	U.FI x 4
Antenna Plenum Rated	N/A
Cable Plenum Rated	N/A
Outdoor Rated	No
Weight	N/A
Storage Temp Range (C)	0°/40°
Operation Temp Range (C)	0°/40°

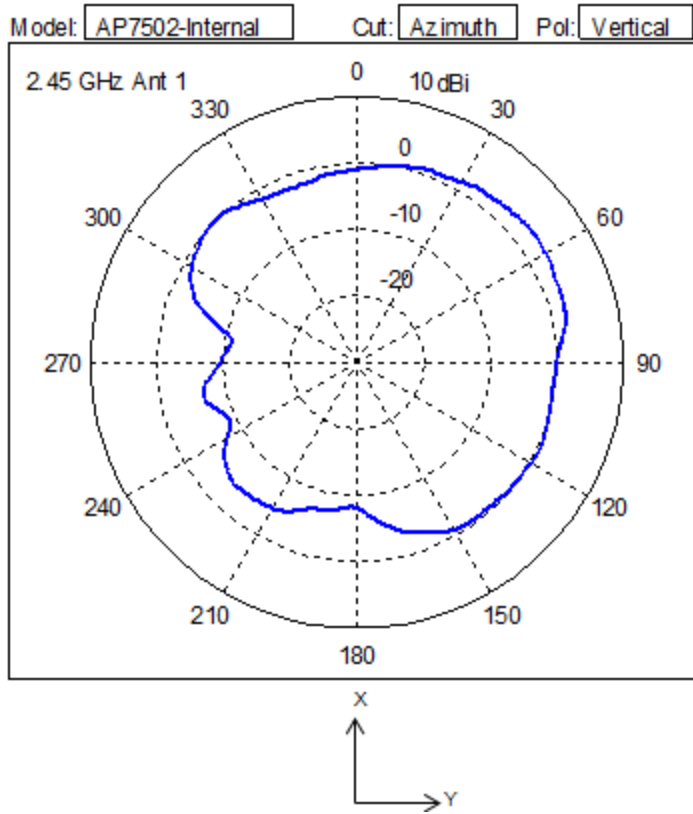

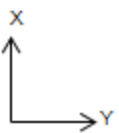
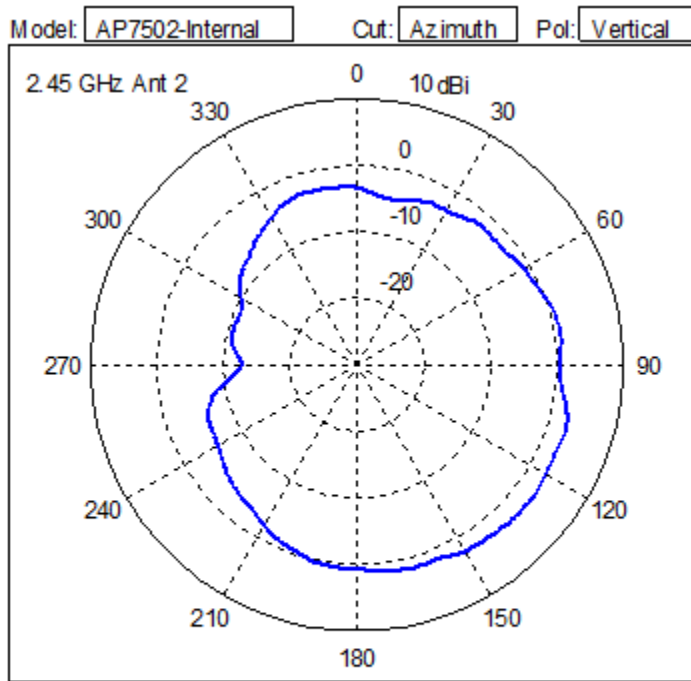
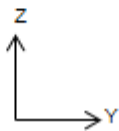
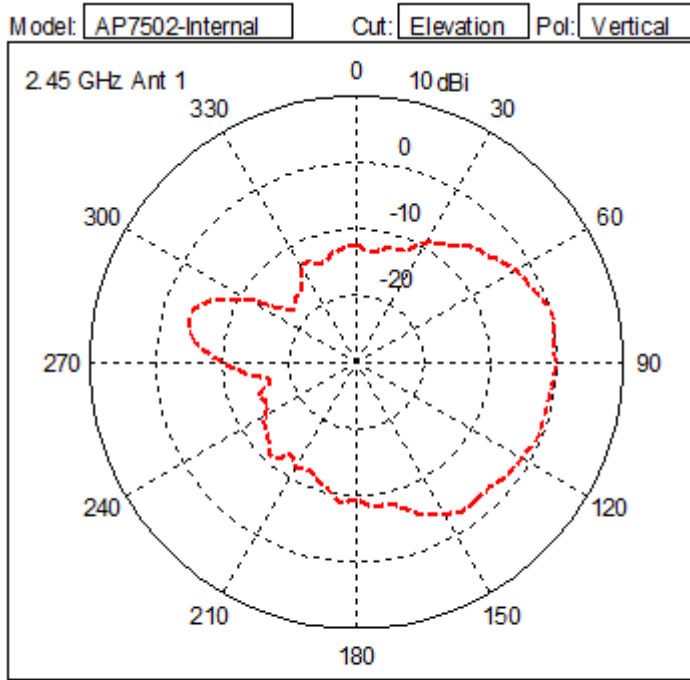

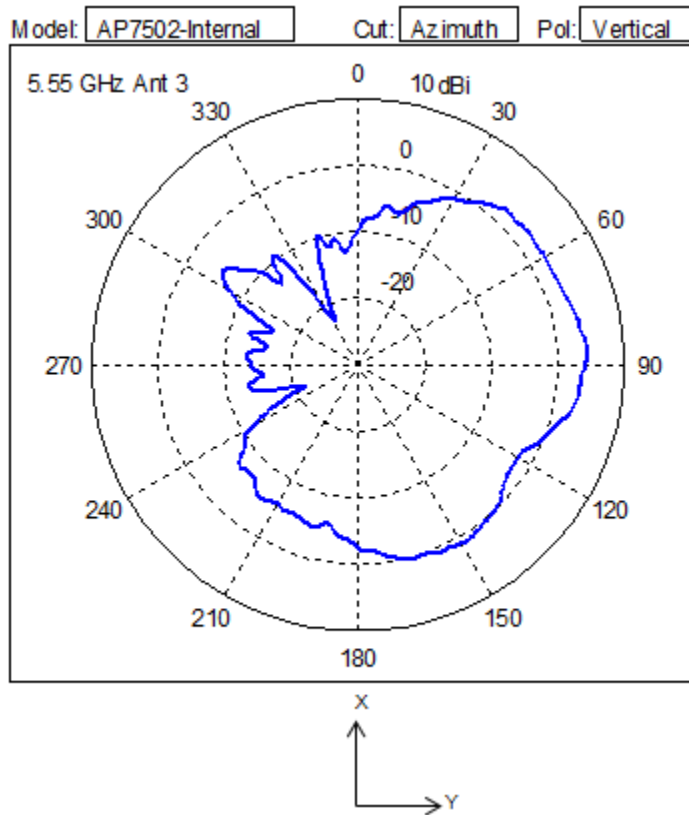
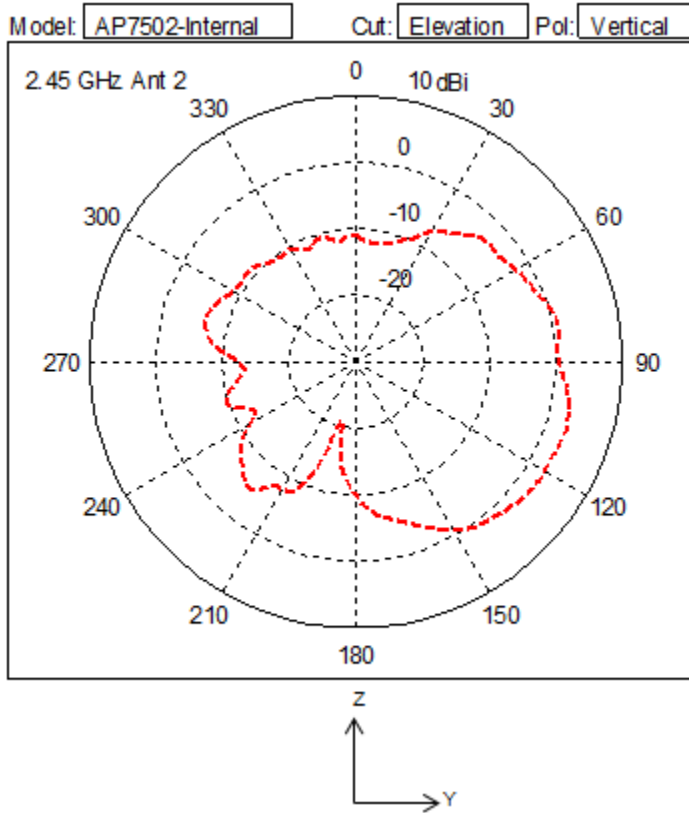

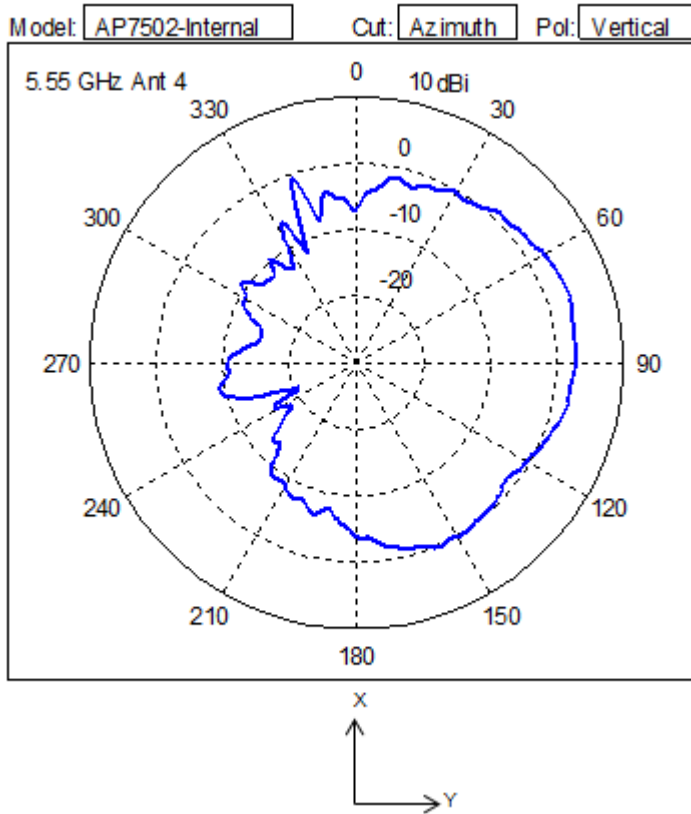
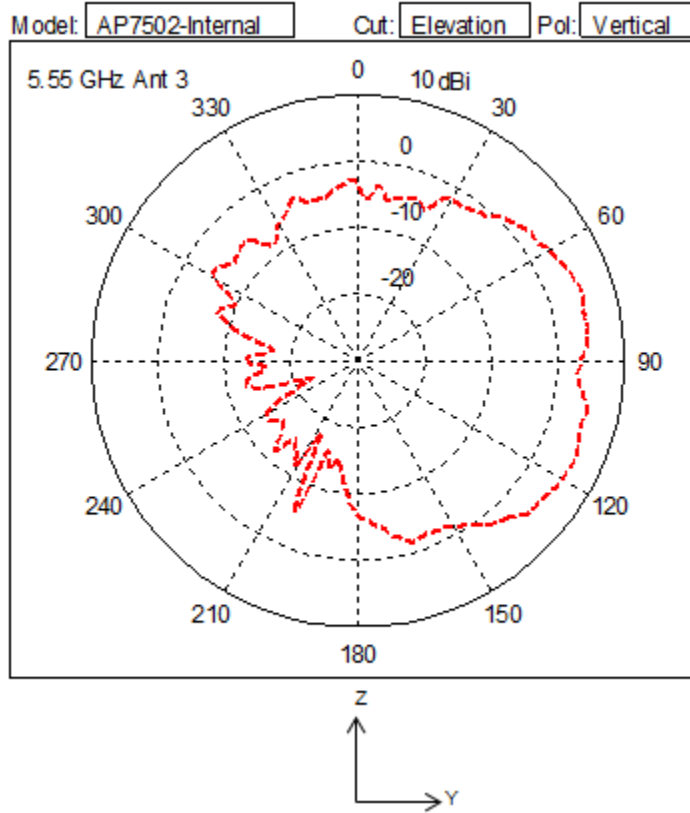

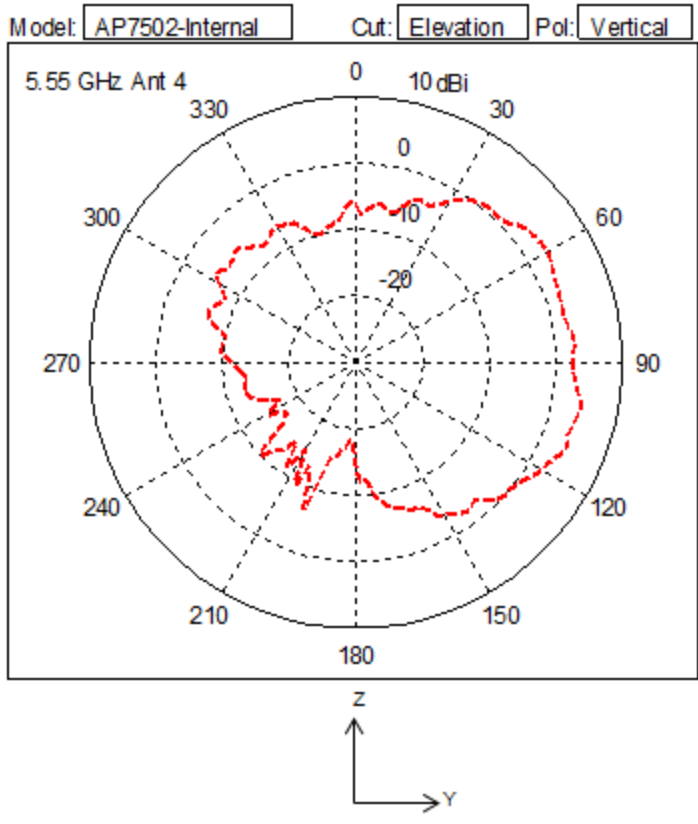

ML-2452-PNL6M3-N36 , 11ABGN, 120° Sector, 3-Port, 6/6 dBi, LP, CBL 36, N-Type-M

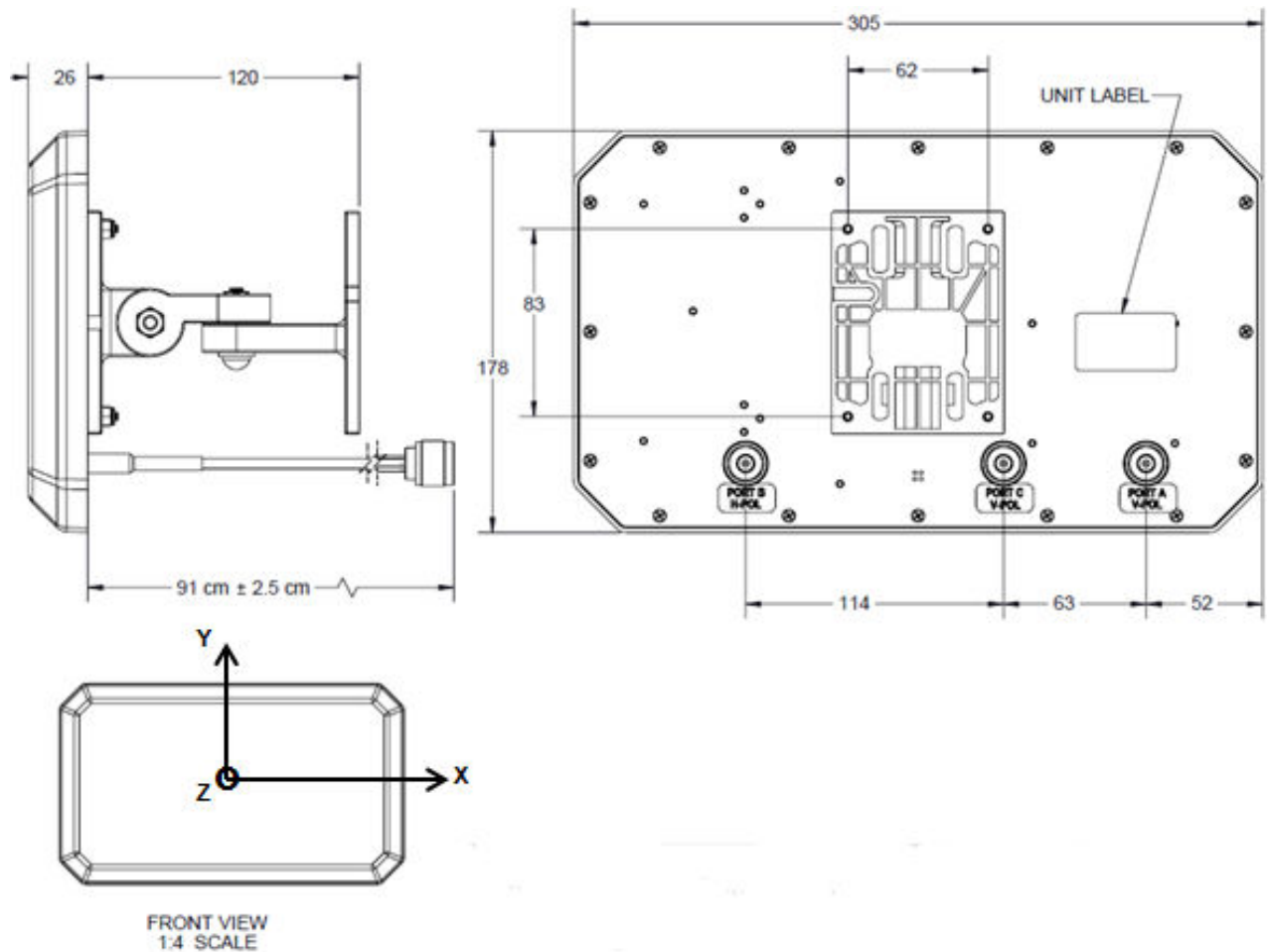

Type	Polarized Panel
Frequency	2400-2500, 4900-5900 MHz
Max Gain (dBi)	6.0 (2.4GHz/5GHz)
Polarization	Port A -Linear, Vertical Port B -Linear, Horizontal Port C -Linear, Vertical
Azimuth 3 dB Beamwidth:	110°/110° (2.4GHz/5GHz)
Elevation 3 dB Beamwidth:	75°/45° (2.4GHz/5GHz)
Max UNII-1 Elevation Gain (dBi)	1.2
Cable Length (centimeters)	91
Cable Type	LMR195 equivalent
Connector Type	N-Type Male x 3
Antenna Plenum Rated	No
Cable Plenum Rated	N/A
Outdoor Rated	Yes

Weight (kgs)	0.69
Storage Temp Range (C)	-40°/85°
Operation Temp Range (C)	-30°/70°

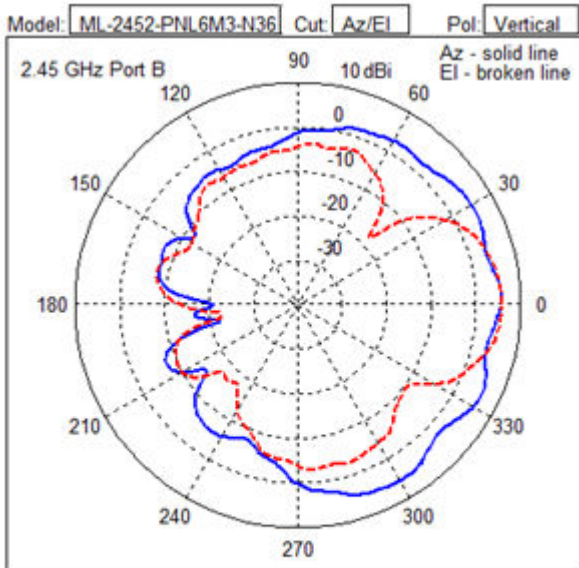
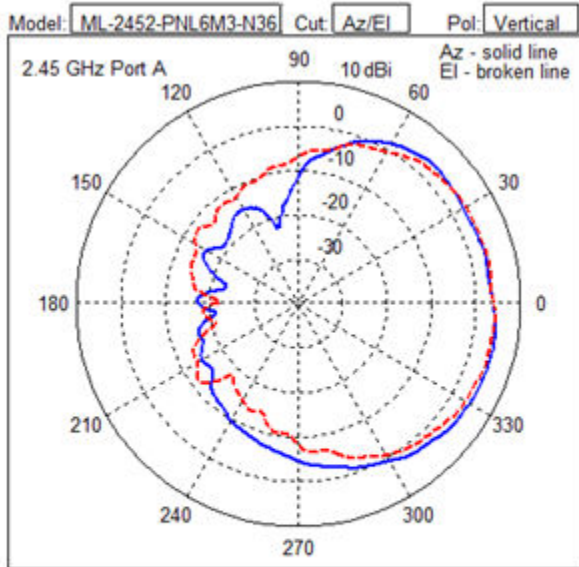

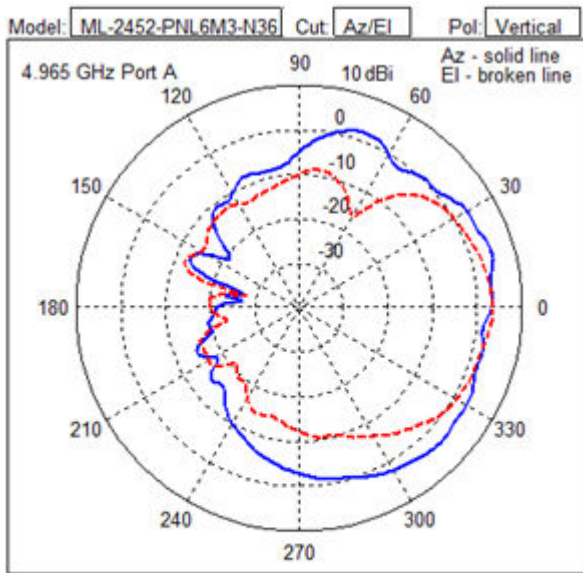
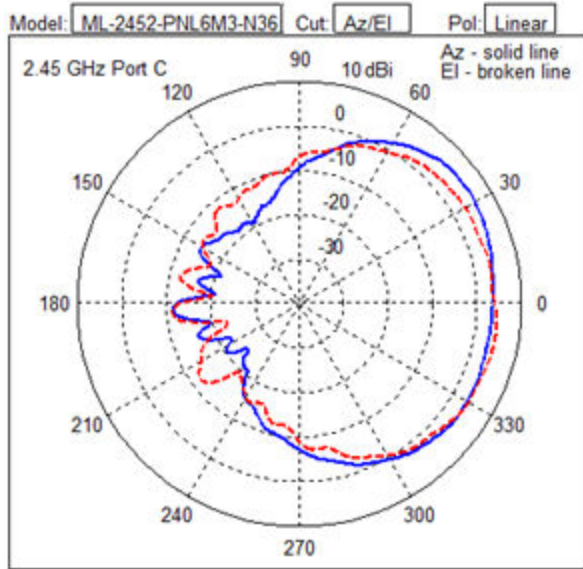

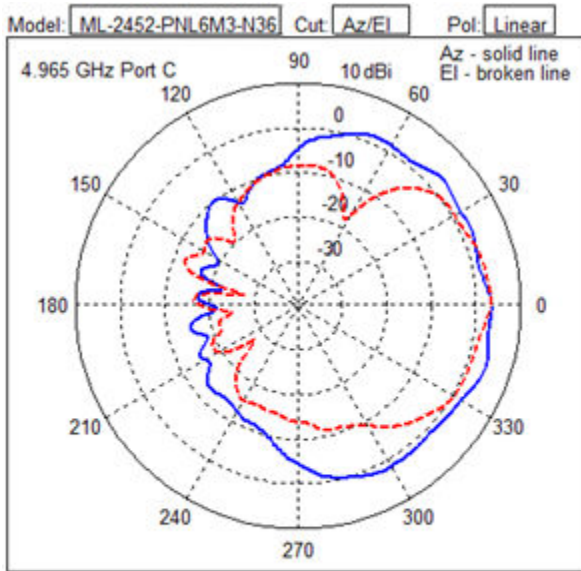
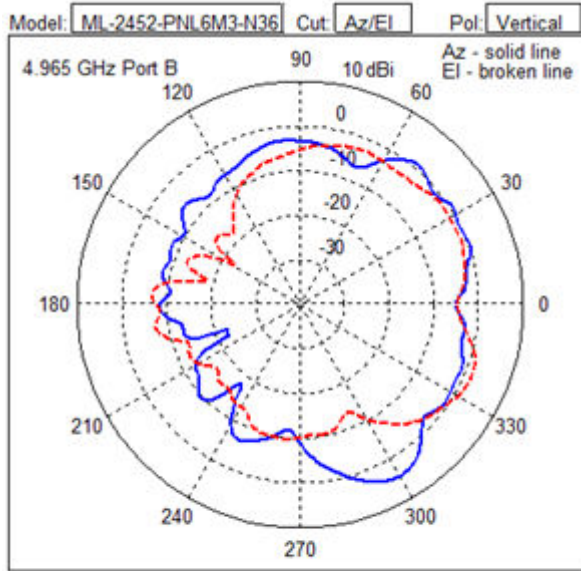

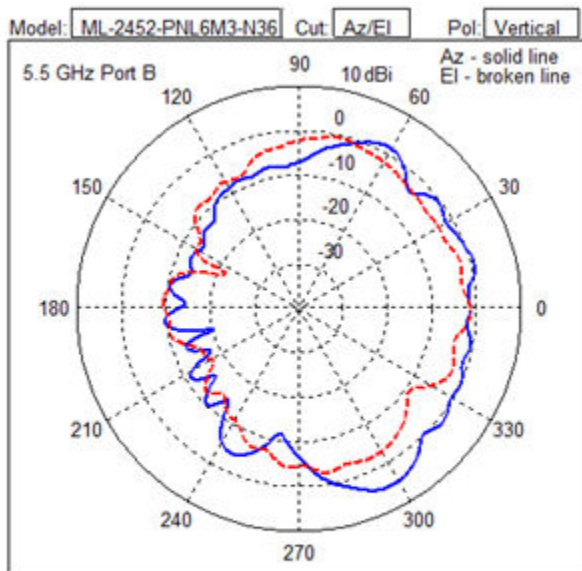
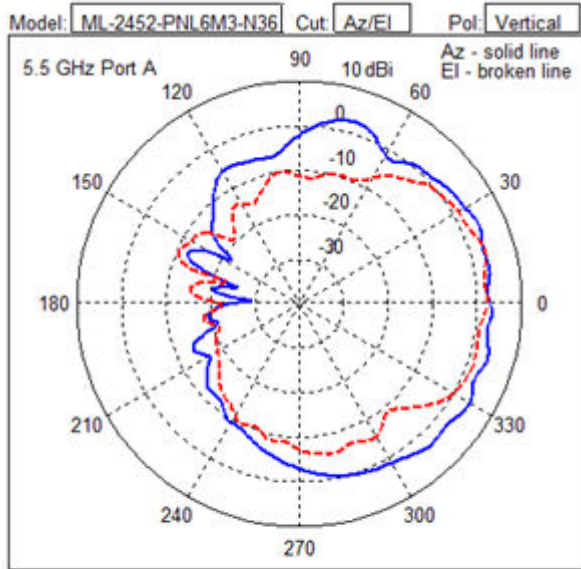

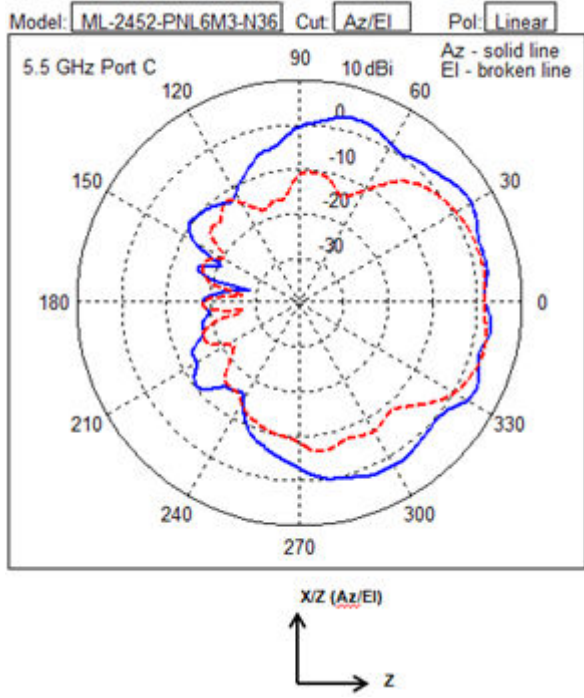

ML-2452-SEC6M3-N36 , 11ABGN, 3-Port, Multi-Pol, Dir Panel, 6.5/5.0 dBi, LP, CBL 36, N-Type-M

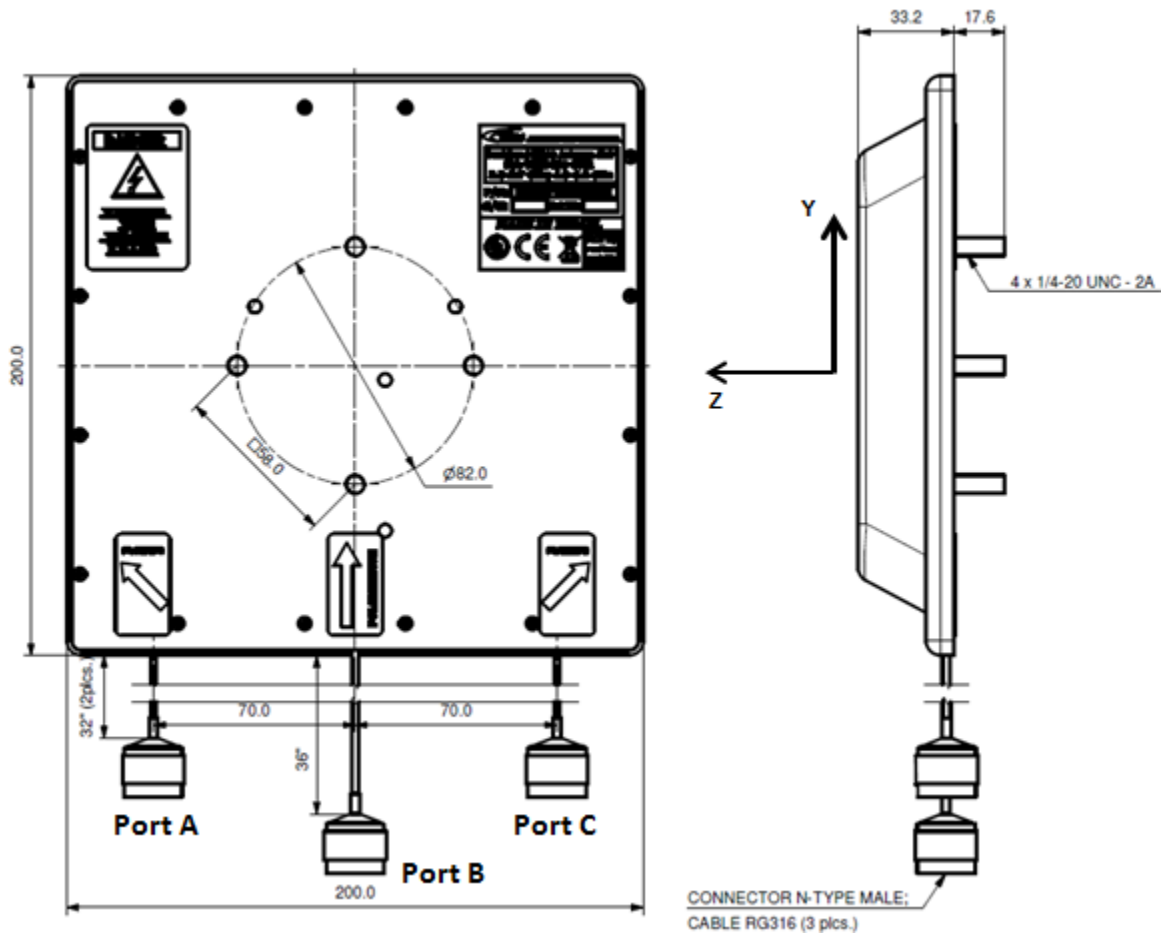

Type	Polarized Panel
Frequency	2300-2700, 4900-6100 MHz
Max Gain (dBi)	6.5/5.0 (2.4GHz/5GHz)
Polarization	Port A -Slant Linear Port B -Vertical, Linear Port C -Slant Linear
Azimuth 3 dB Beamwidth:	Port A - 90°/90° Port B - 120°/140° Port C - 90°/90°
Elevation 3 dB Beamwidth:	Port A - 90°/90° Port B - 70°/80° Port C - 90°/90°
Max UNII-1 Elevation Gain (dBi)	3.4
Cable Length (centimeters)	98
Cable Type	RG316, 98
Connector Type	N-Type Male x 3
Antenna Plenum Rated	Yes
Cable Plenum Rated	N/A
Outdoor Rated	Yes
Weight (kgs)	0.88

Storage Temp Range (C)	-40°/70°
Operation Temp Range (C)	-40°/70°

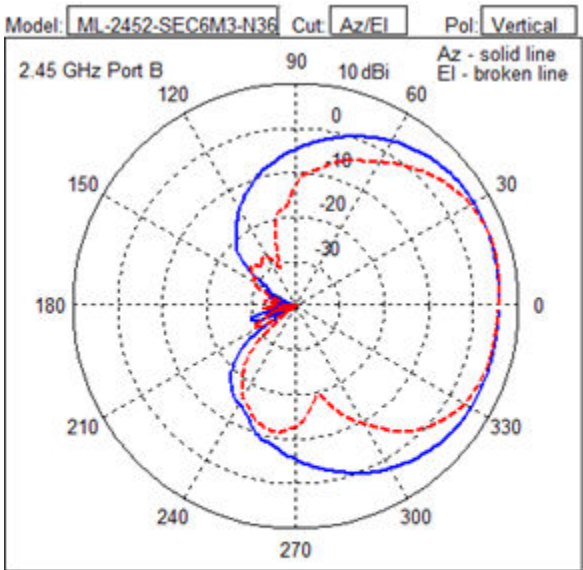
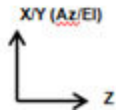
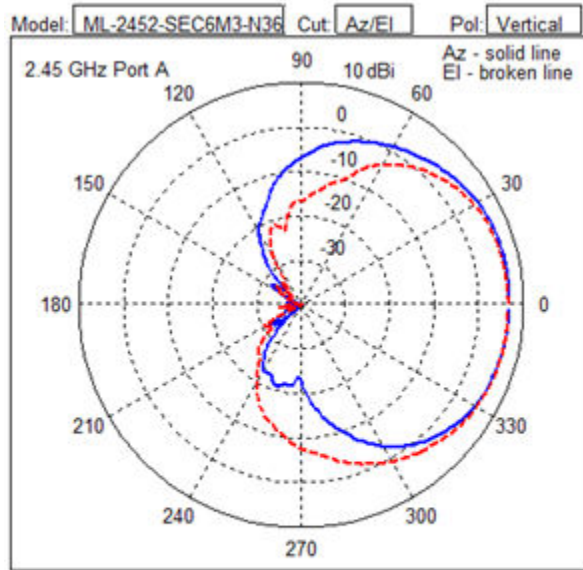

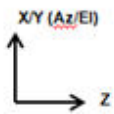
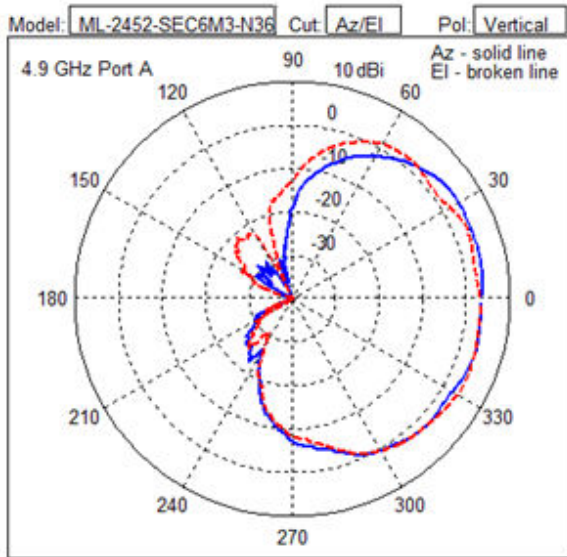
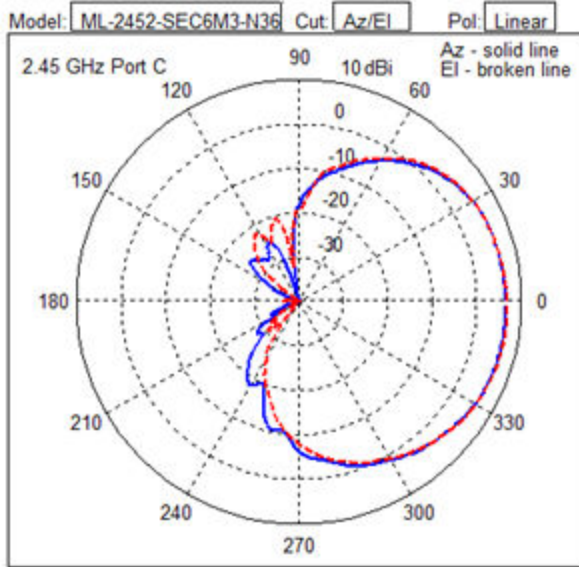

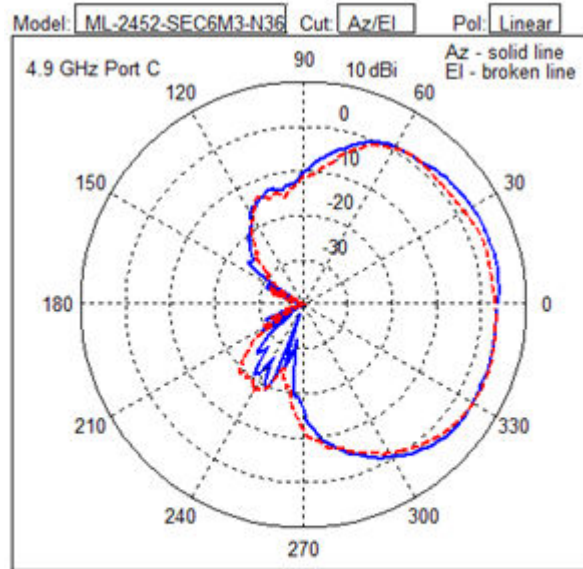
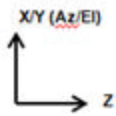
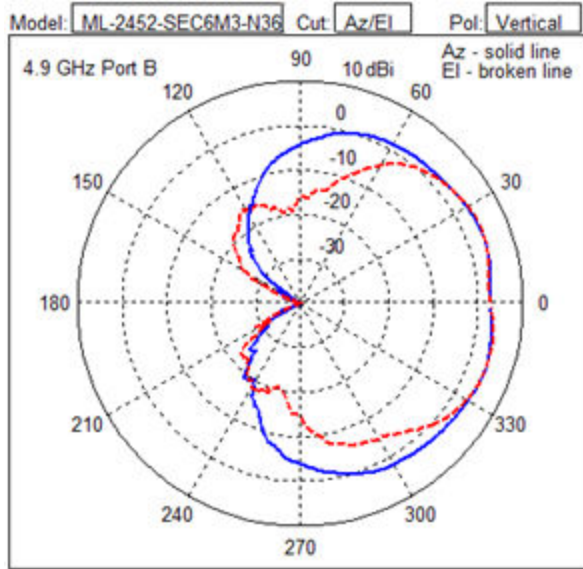

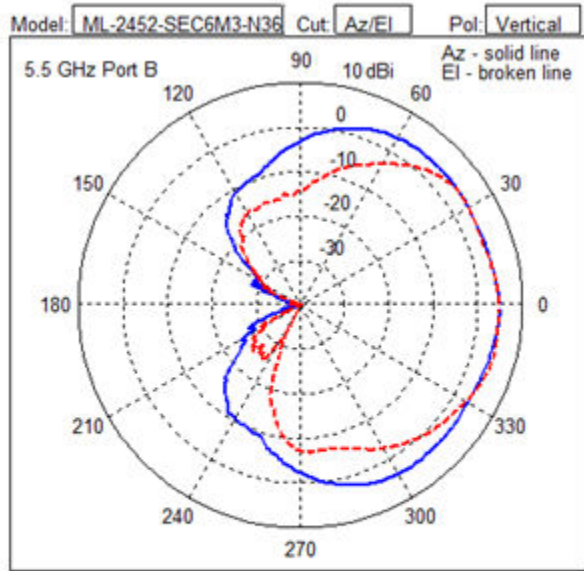
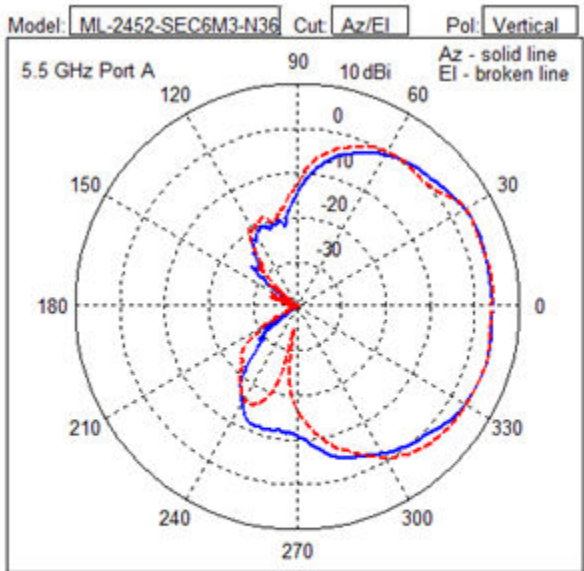

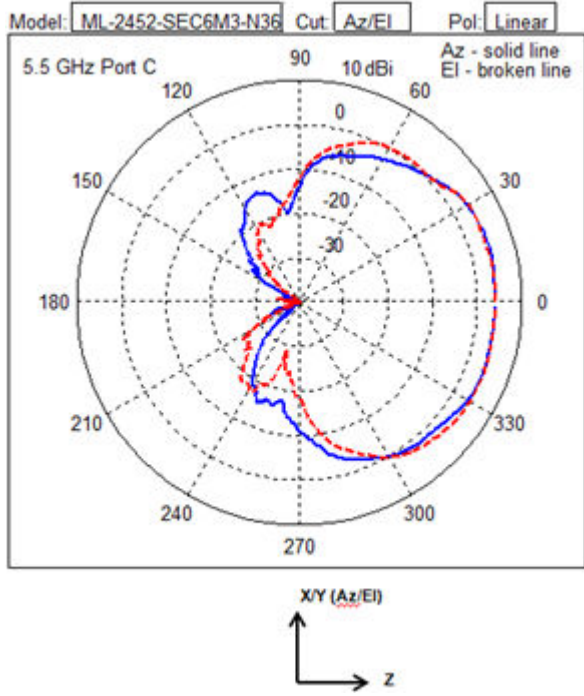

ML-2452-VMM5M3-N72, 11ABGN, 3-Port Dual-Band, Vertical Polarization Omni Array

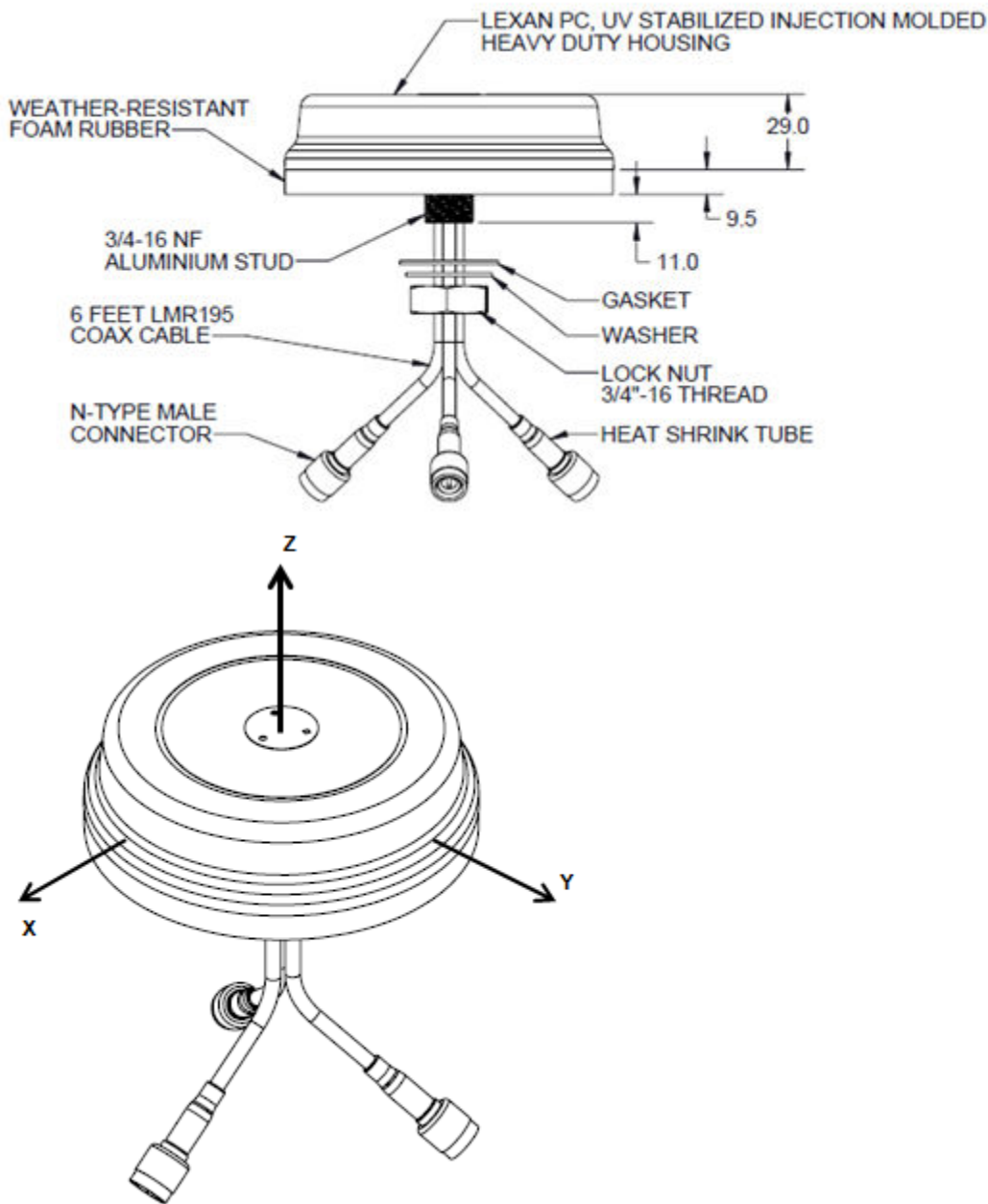

Type	Dipole
Frequency	2400-2500, 4900-5875 MHz
Max Gain (dBi)	4.5/5.4 (2.4GHz/5GHz)
Polarization	Port A -Linear, Vertical Port B -Linear, Vertical Port C -Linear, Vertical
Azimuth 3 dB Beamwidth:	Port A - 360°/360° Port B - 360°/360° Port C - 360°/360°

Elevation 3 dB Beamwidth:	Port A - 40°/30° Port B - 40°/30° Port C - 40°/30°
Cable Length (centimeters)	182.8
Cable Type	LMR195 equivalent
Connector Type	N-Type Male x 3
Antenna Plenum Rated	No
Cable Plenum Rated	N/A
Outdoor Rated	Yes
Weight (kgs)	0.61
Storage Temp Range (C)	-35°/80°
Operation Temp Range (C)	-35°/80°

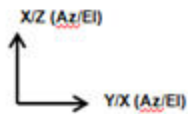
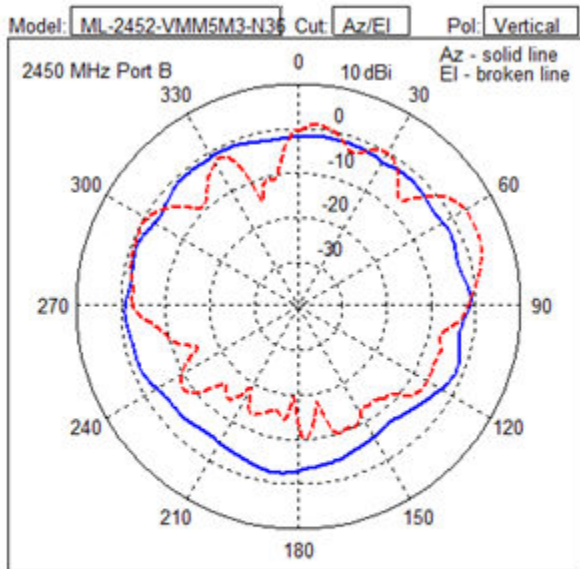
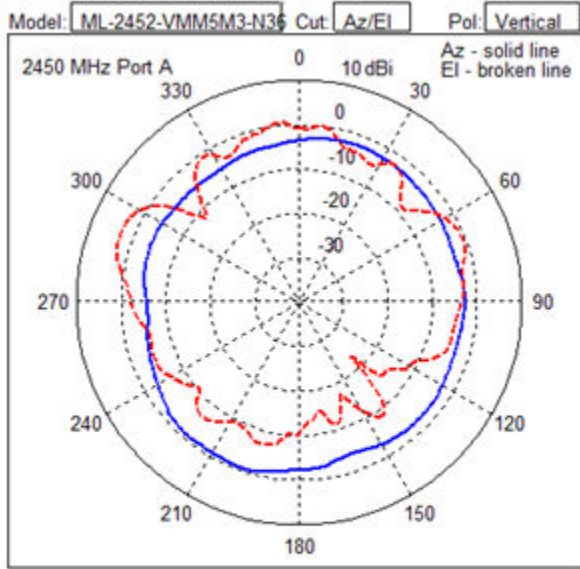

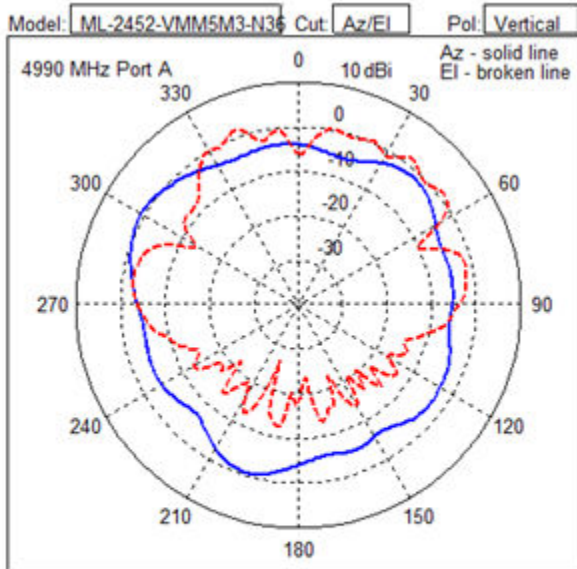
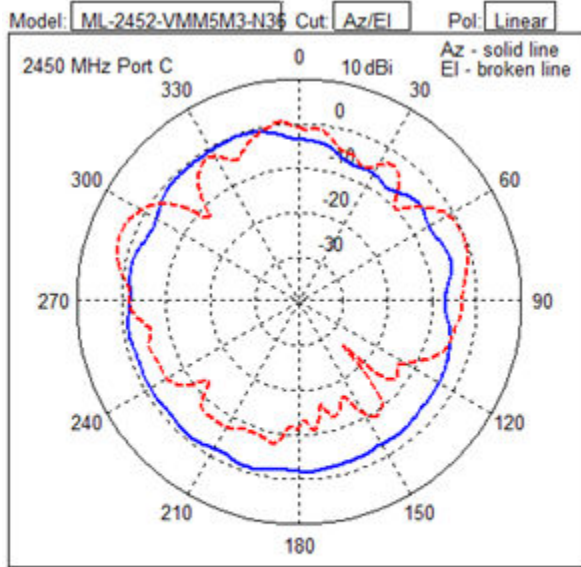

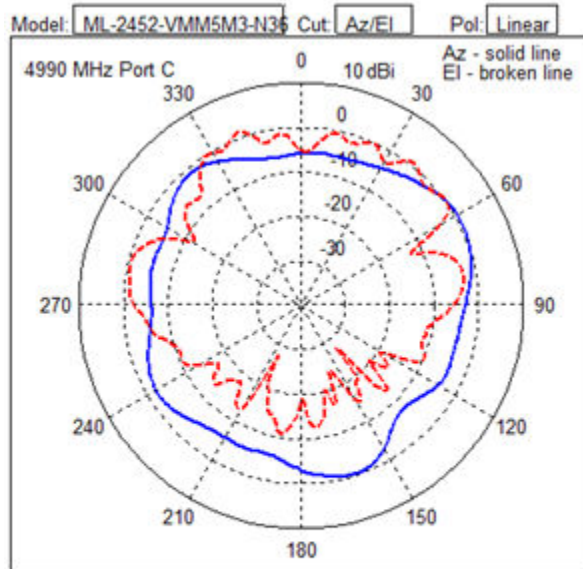
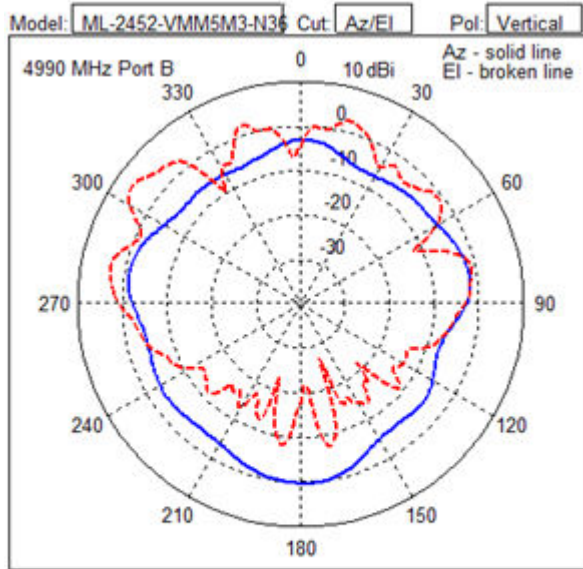

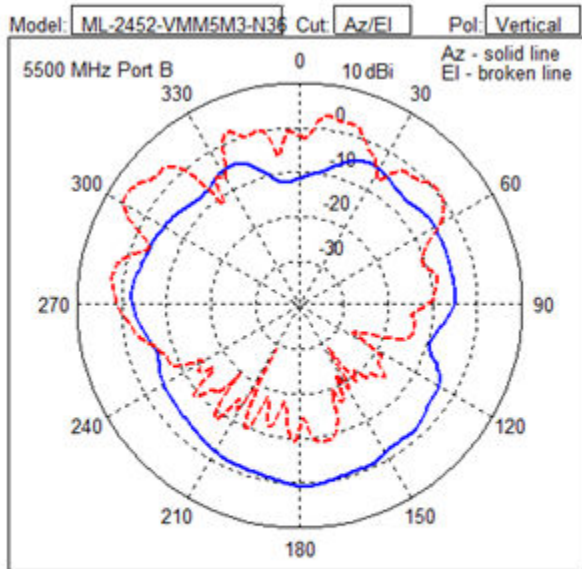
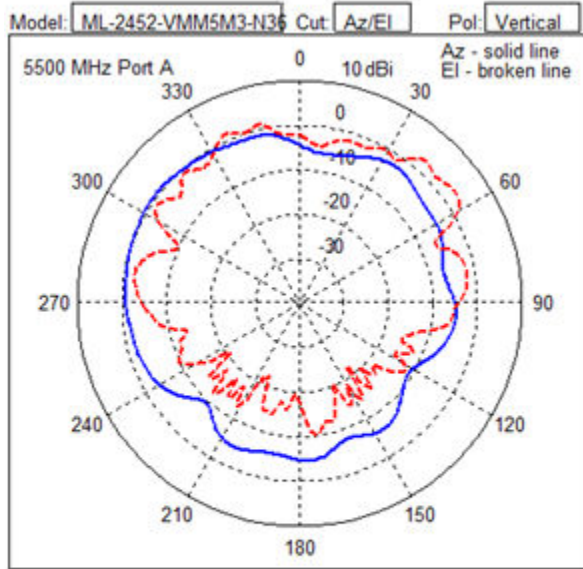

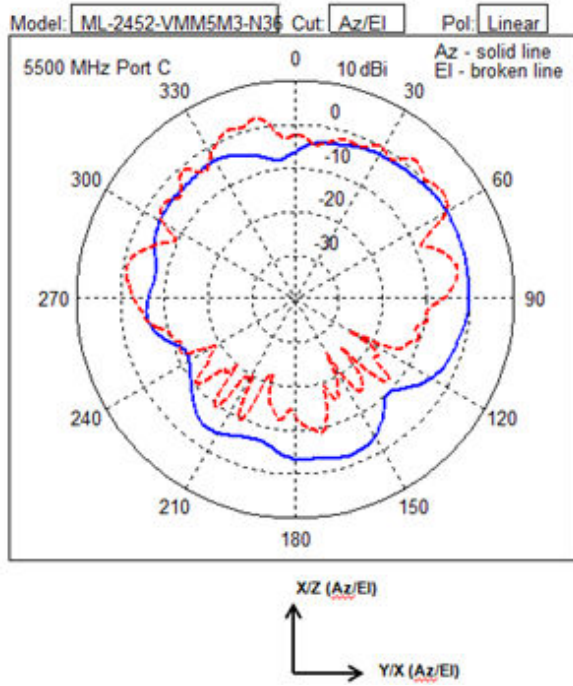

ML-2452-PNL9M3-N36, 11ABGN, 3-Port Dual-Band, Dual Polarization Dir Panel 2 V-Pol and 1 H-Pol ports

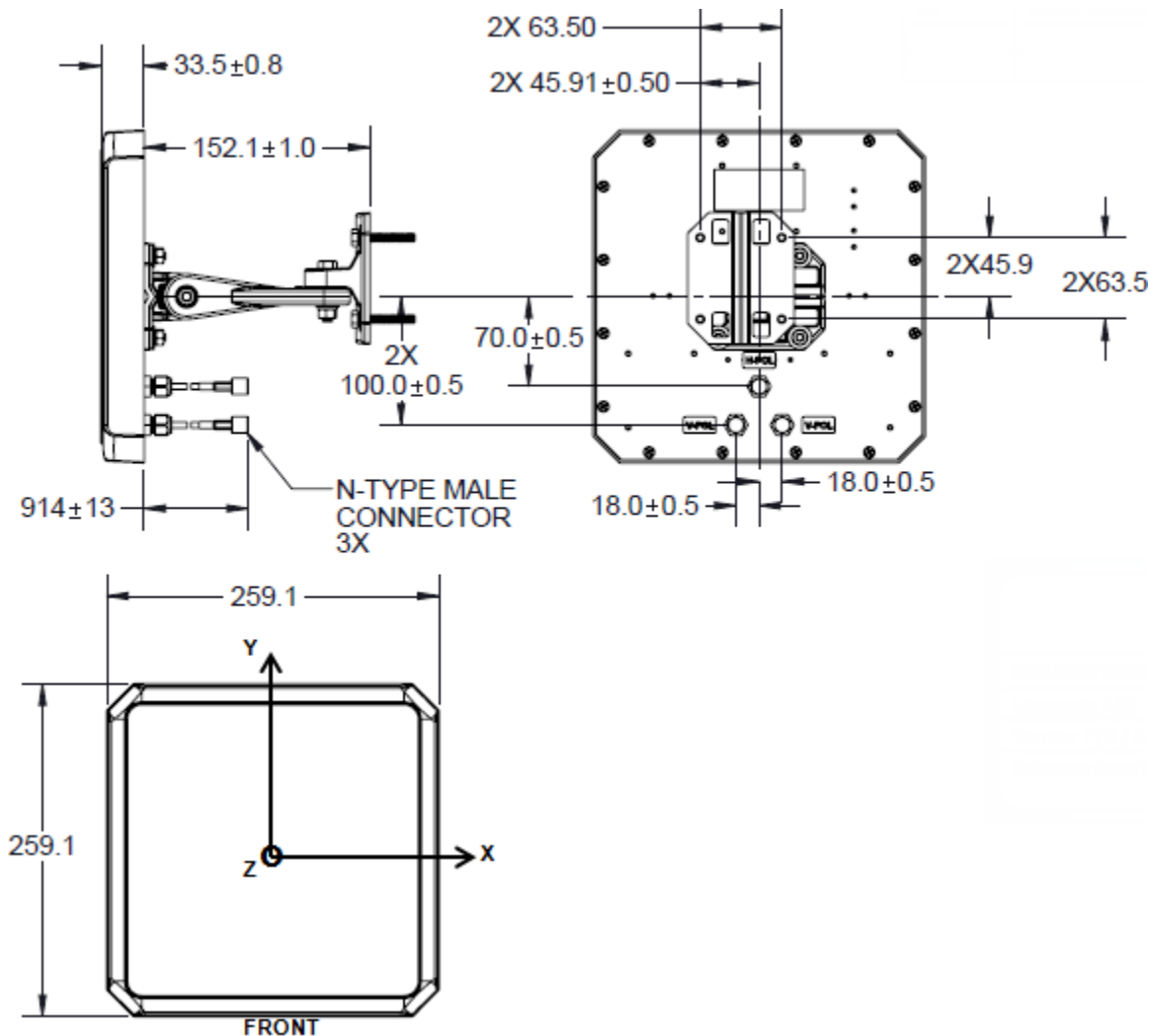

Type	Polarized Panel
Frequency	2400-2500, 5150-5875 MHz
Max Gain (dBi)	11.0/10.7 (2.4GHz/5GHz)
Polarization	Port A -Linear, Vertical Port B -Linear, Horizontal Port C -Linear, Vertical
Azimuth 3 dB Beamwidth:	Port A - 75°/55° Port B - 75°/55° Port C - 75°/55°
Elevation 3 dB Beamwidth:	Port A - 70°/60° Port B - 70°/60° Port C - 70°/60°
Cable Length (centimeters)	91
Cable Type	LMR195 equivalent
Connector Type	N-Type Male x 3
Antenna Plenum Rated	No

Cable Plenum Rated	N/A
Outdoor Rated	Yes
Weight (kgs)	0.80
Storage Temp Range (C)	-40°/70°
Operation Temp Range (C)	-30°/65°

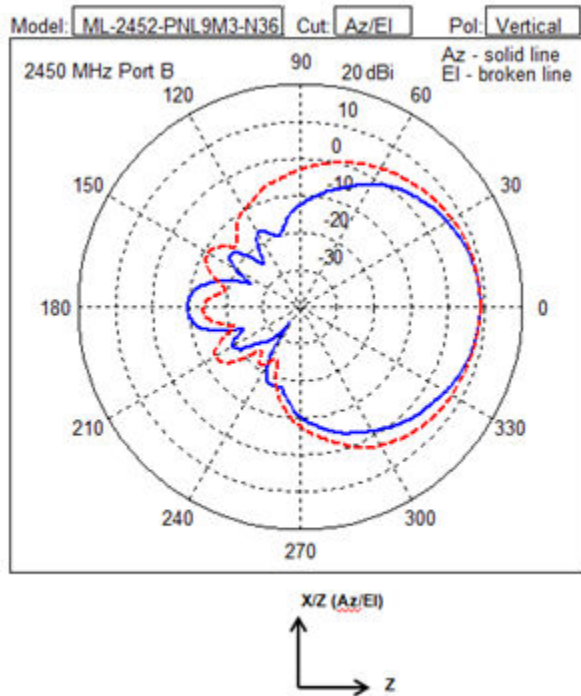
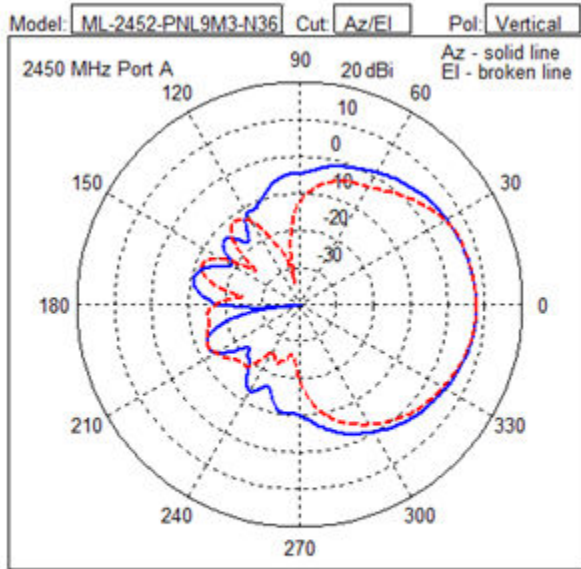

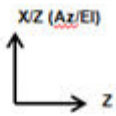
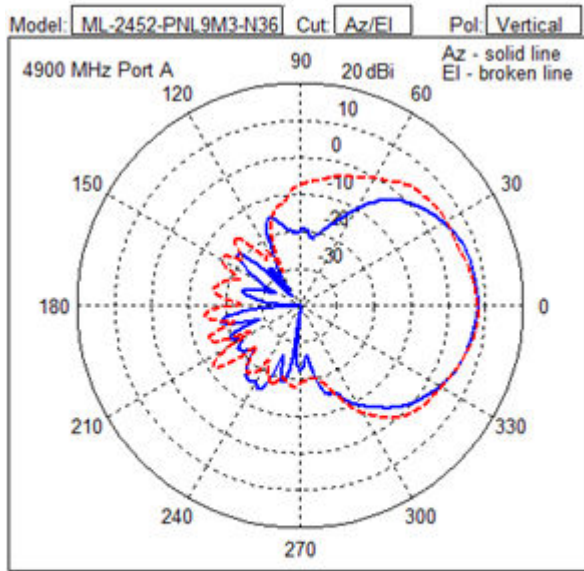
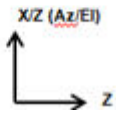
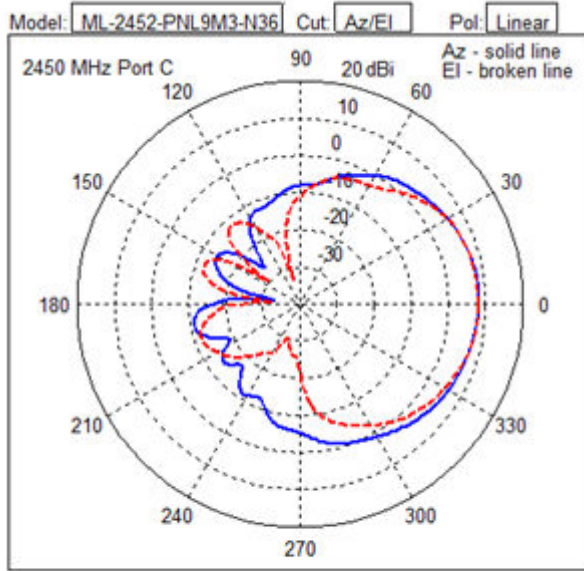

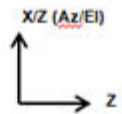
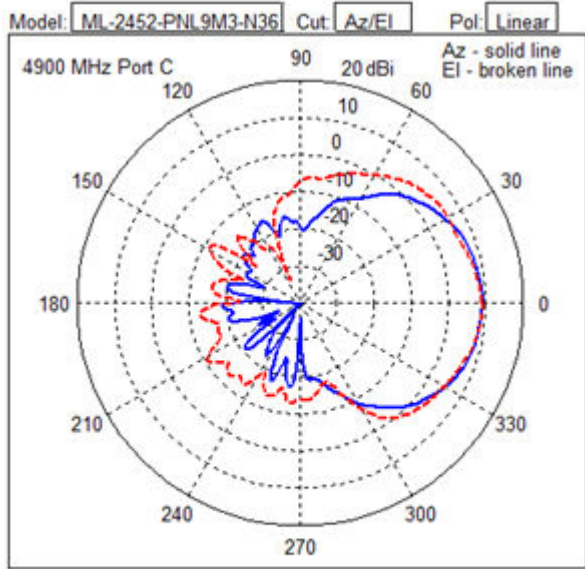
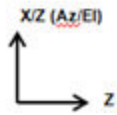
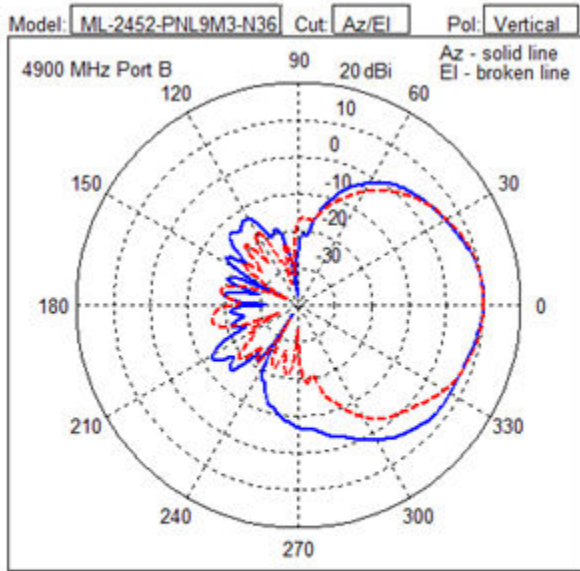

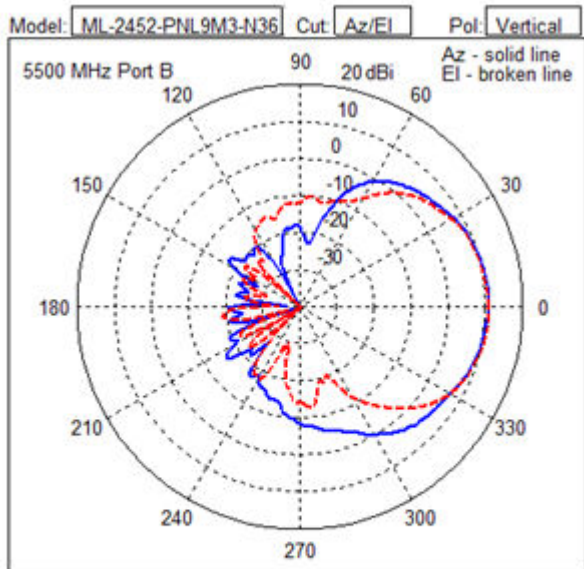
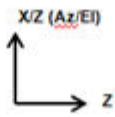
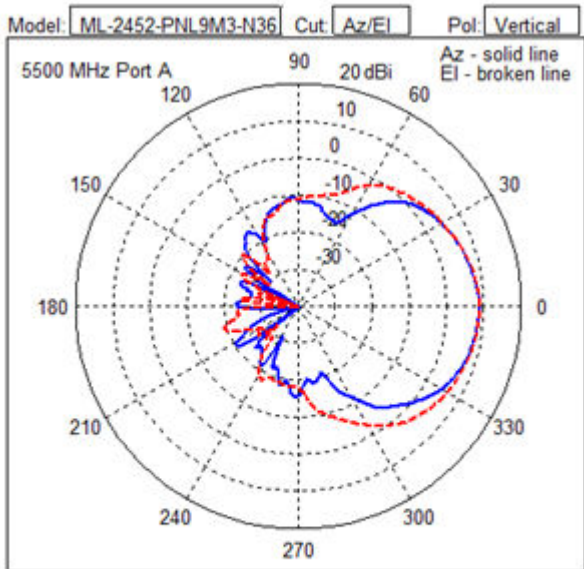

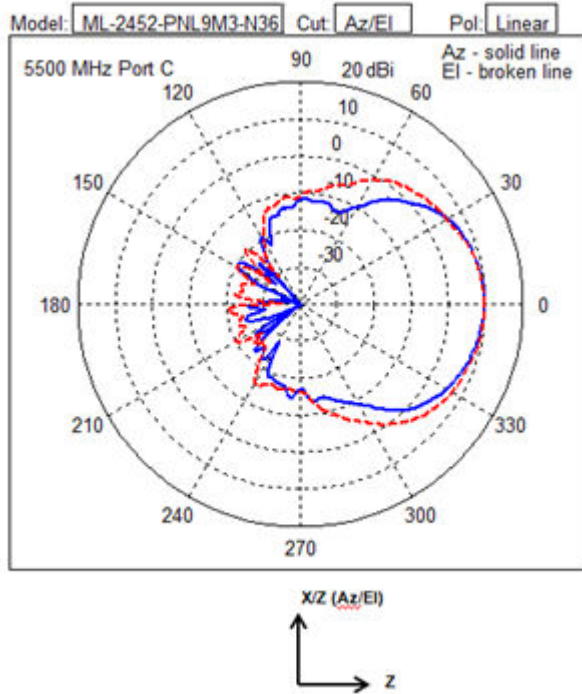

AP7562 Facade Antenna



Radio 1	
Frequency (MHz)	2400-2500
Max gain (dBi)	4.8
Polarization	Linear, Vertical
Azimuth beam width (degrees)	360

Elevation beam width (degrees)	160
Radio 2	
Frequency (MHz)	5180-5850
Max gain (dBi)	6.4
Elevation gain (dBi)	5.4
Polarization	Linear, Vertical
Azimuth beam width (degrees)	360
Elevation beam width (degrees)	160
Additional Parameters	
Cable Length (in.)	N/A
Cable Type	N/A
Antenna Plenum Rated	N/A
Cable Plenum Rated	N/A
Outdoor Rated	No
Weight (kgs)	N/A
Storage Temp Range (C)	-40°/70°
Operation Temp Range (C)	-40°/70°

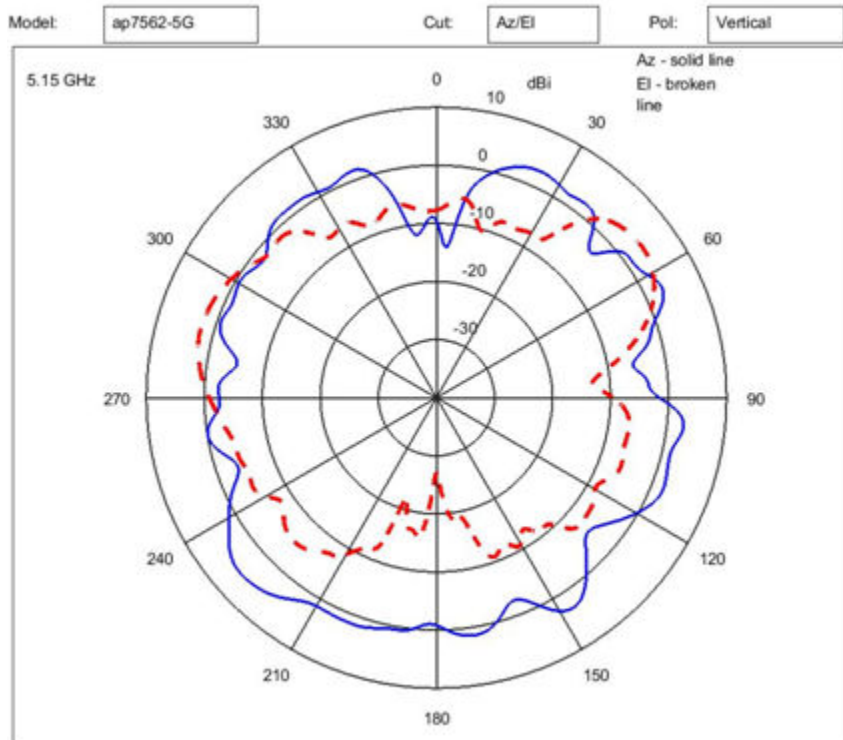
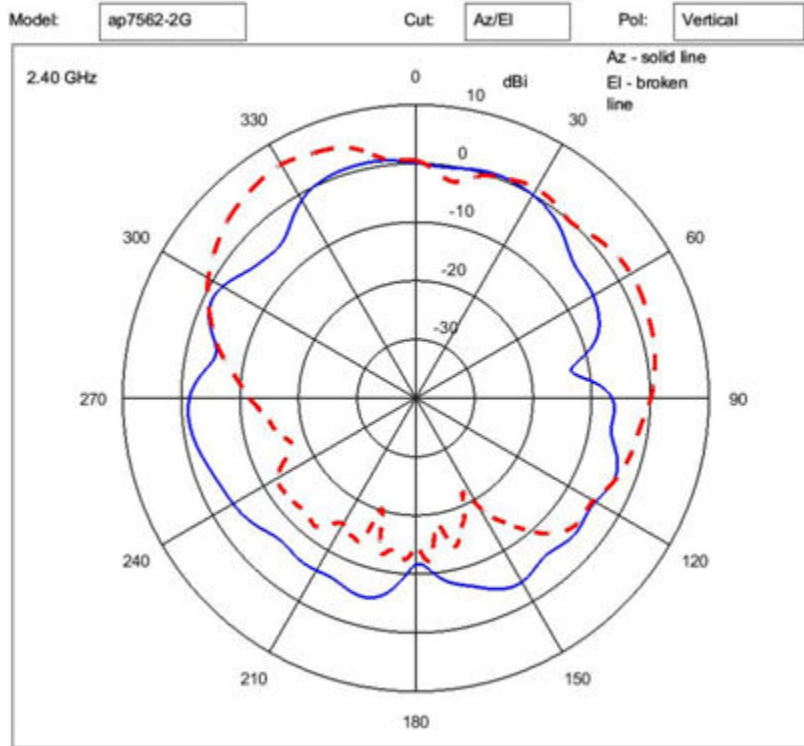

AP8432 Dual-Band Internal Antenna (2.4/5 GHz)

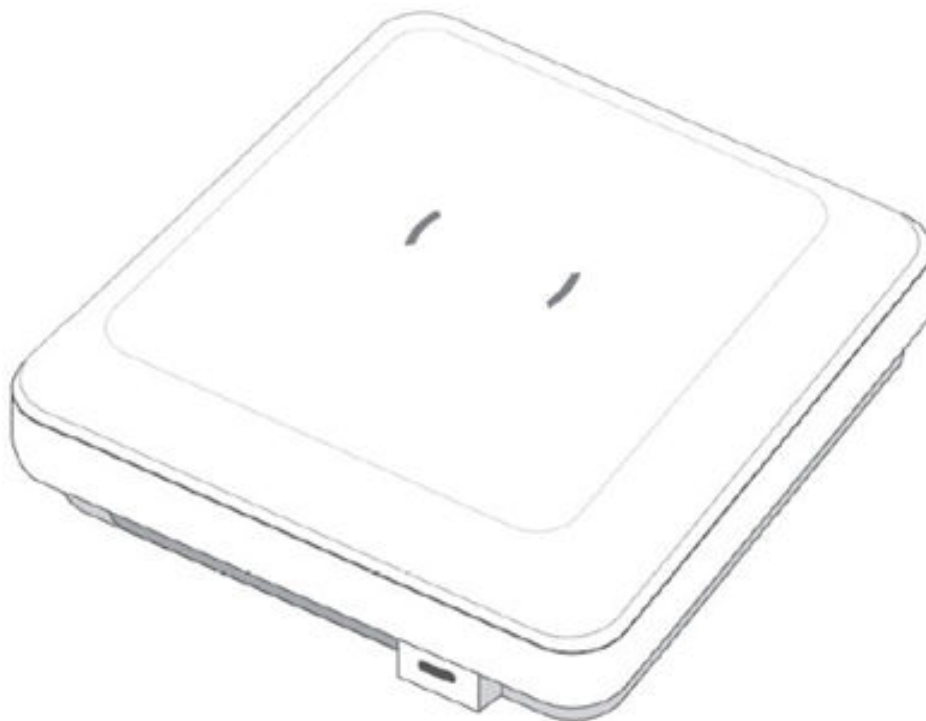

Radio 1	
Frequency (MHz)	2400-2500, 5000-6000
Max gain (dBi)	4.4/5.9
Elevation gain (dBi)	4.1
Polarization	Linear, Vertical
Azimuth beam width (degrees)	360
Elevation beam width (degrees)	160
Radio 2 (Data Radio)	
Frequency (MHz)	5000-6000
Max gain (dBi)	6.8
Elevation gain (dBi)	3.4
Polarization	Linear, Vertical
Azimuth beam width (degrees)	360
Elevation beam width (degrees)	160
Radio 3 (Bluetooth Radio)	
Frequency (MHz)	2400-2500
Max gain (dBi)	7.7
Elevation gain (dBi)	N/A
Polarization	Linear, Vertical

Azimuth beam width (degrees)	360
Elevation beam width (degrees)	100
Additional Parameters	
Cable Length (in.)	N/A
Cable Type	N/A
Antenna Plenum Rated	N/A
Cable Plenum Rated	N/A
Outdoor Rated	No
Weight (kgs)	N/A
Storage Temp Range (C)	-40°/70°
Operation Temp Range (C)	-40°/70°

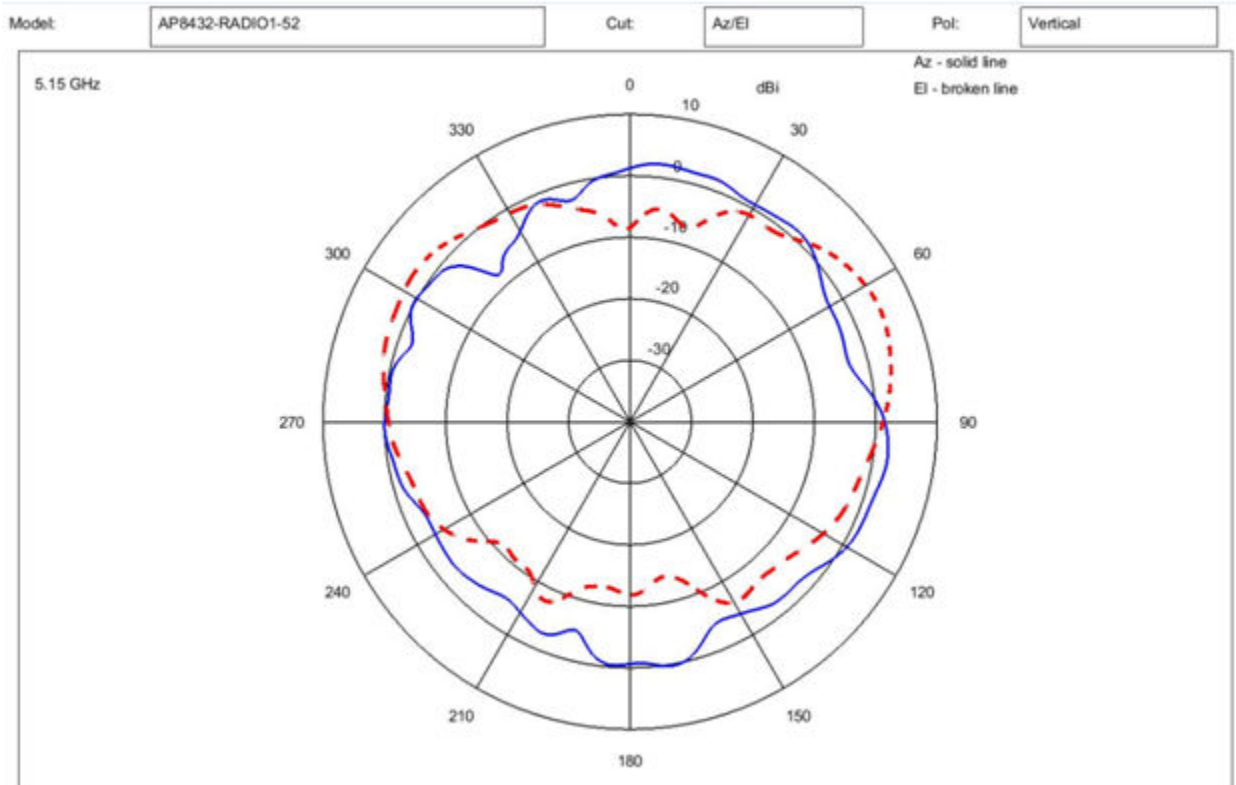
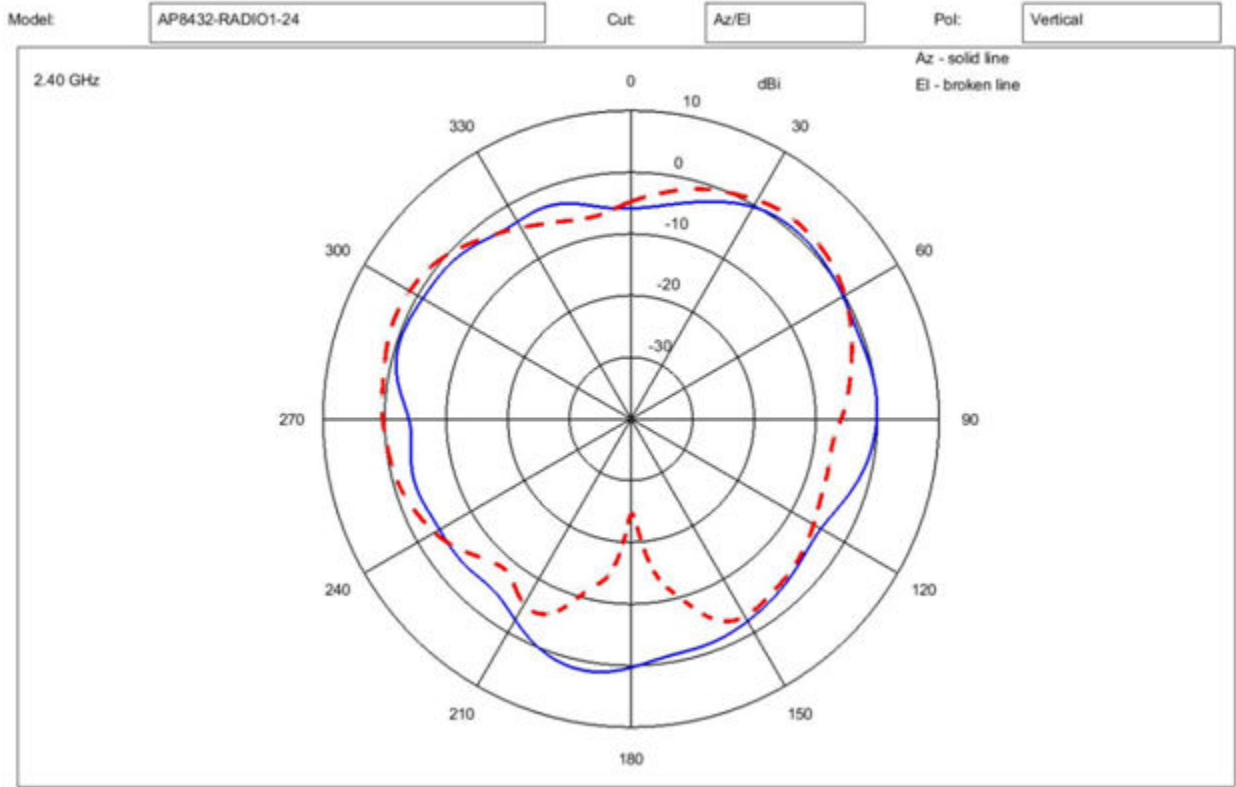

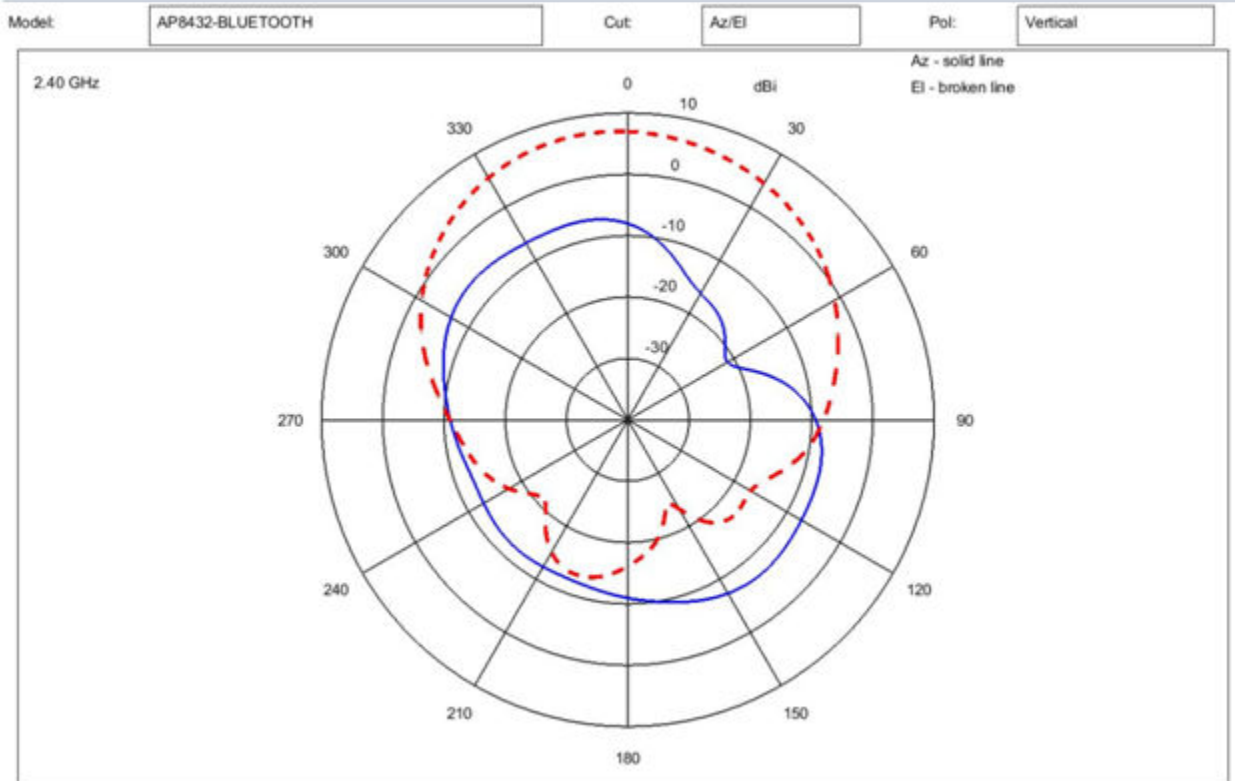
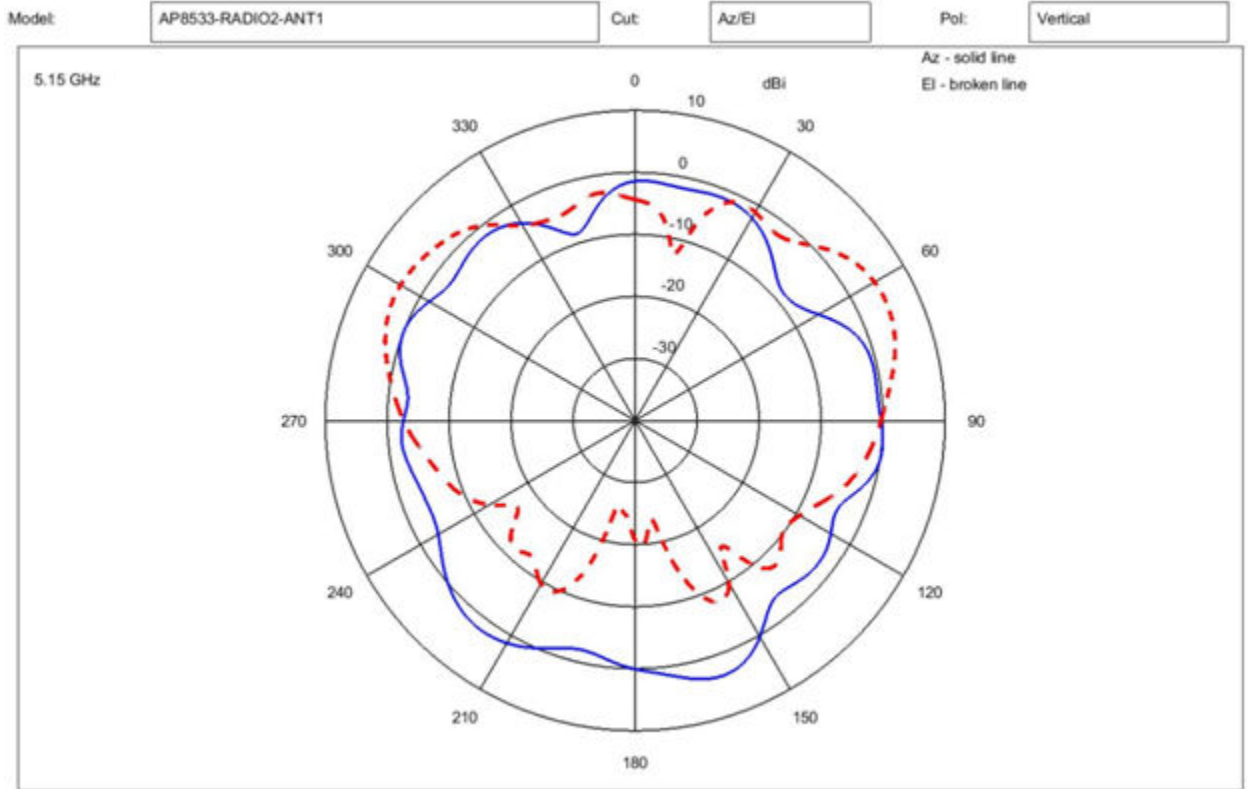

AP8533i Dual-Band Internal Antenna (2.4/5 GHz)

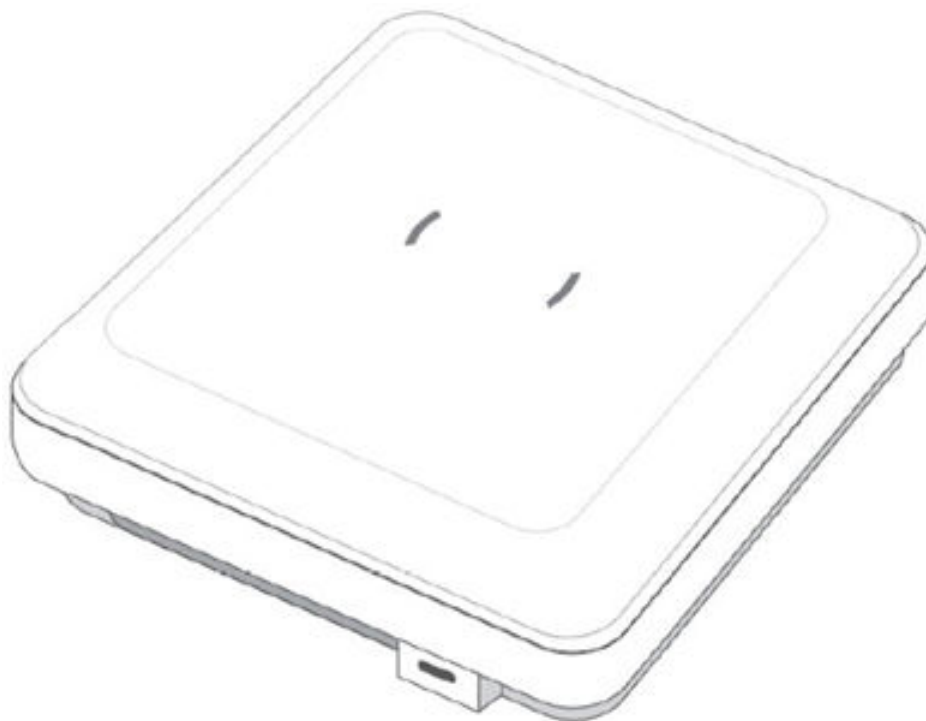

Radio 1 (Data Radio)	
Frequency (MHz)	2400-2500
Max gain (dBi)	5.2
Elevation gain (dBi)	N/A
Polarization	Linear, Vertical
Azimuth beam width (degrees)	360
Elevation beam width (degrees)	160
Radio 1 (Sensor Radio)	
Frequency (MHz)	2400-2500, 5000-6000
Max gain (dBi)	4.4
Elevation gain (dBi)	N/A
Polarization	Linear, Vertical
Azimuth beam width (degrees)	360
Elevation beam width (degrees)	160
Radio 2 (Data Radio)	
Frequency (MHz)	5000-6000
Max gain (dBi)	6.8
Elevation gain (dBi)	3.4
Polarization	Linear, Vertical

Azimuth beam width (degrees)	360
Elevation beam width (degrees)	160
Radio 3 (Sensor Radio)	
Frequency (MHz)	2400-2500, 5000-6000
Max gain (dBi)	4.4/5.9
Elevation gain (dBi)	4.1
Polarization	Linear, Vertical
Azimuth beam width (degrees)	360
Elevation beam width (degrees)	100
Radio 4 (Bluetooth Radio)	
Frequency (MHz)	2400-2500
Max gain (dBi)	7.7
Elevation gain (dBi)	NA
Polarization	Linear, Horizontal
Azimuth beam width (degrees)	360
Elevation beam width (degrees)	100
Additional Parameters	
Cable Length (in.)	N/A
Cable Type	N/A
Antenna Plenum Rated	N/A
Cable Plenum Rated	N/A
Outdoor Rated	No
Weight (kgs)	N/A
Storage Temp Range (C)	-40°/70°
Operation Temp Range (C)	-40°/70°

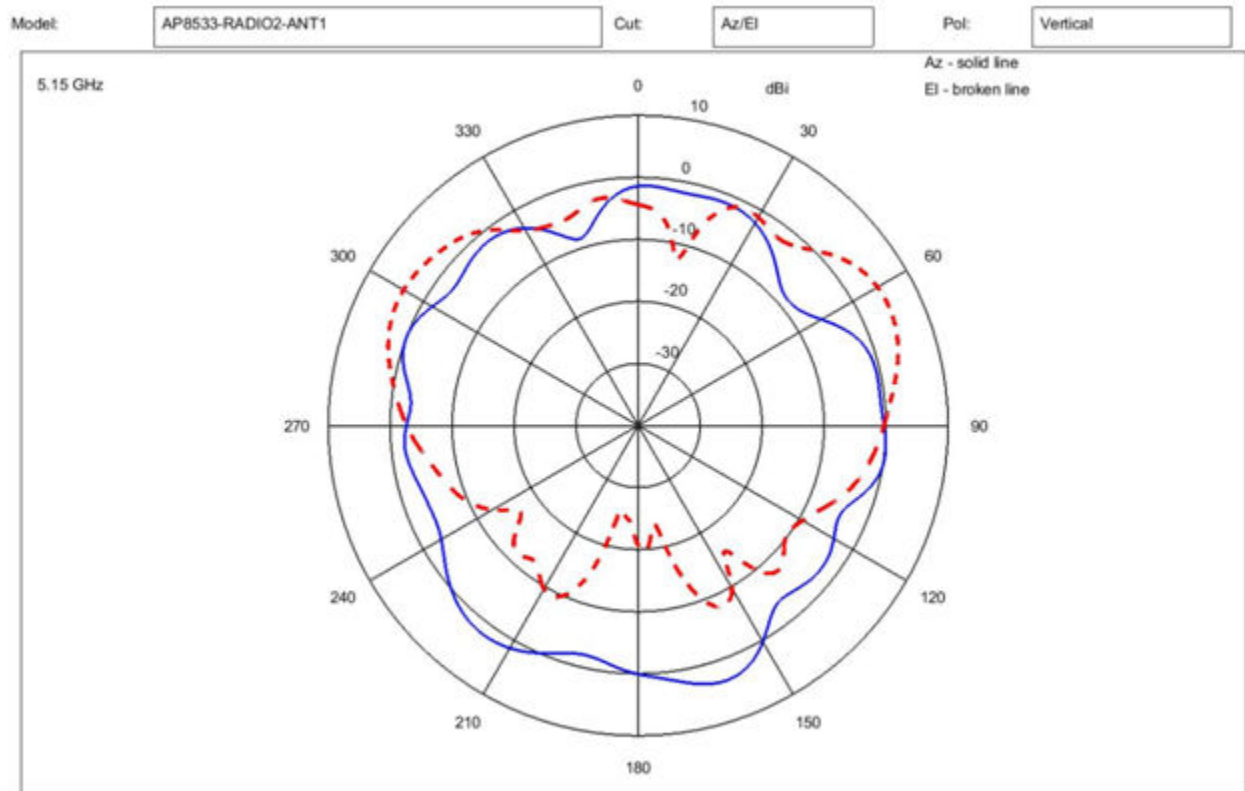
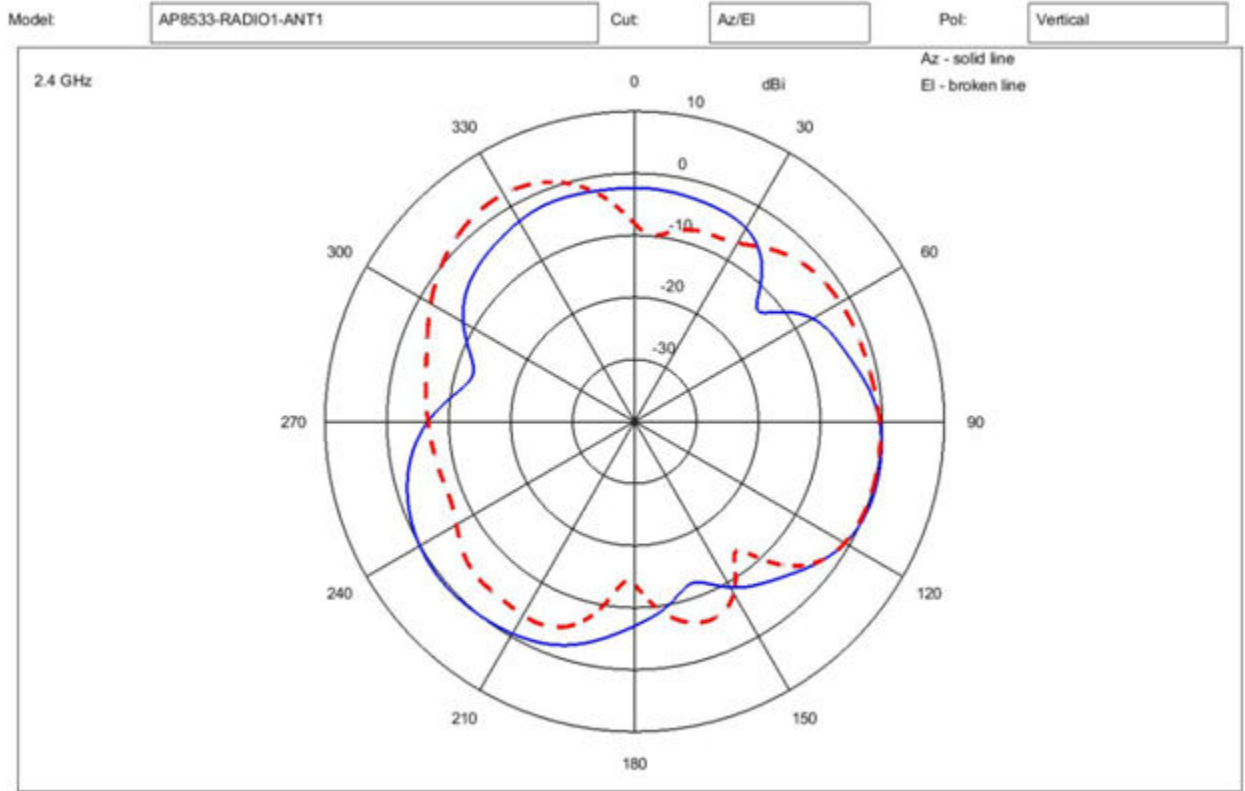

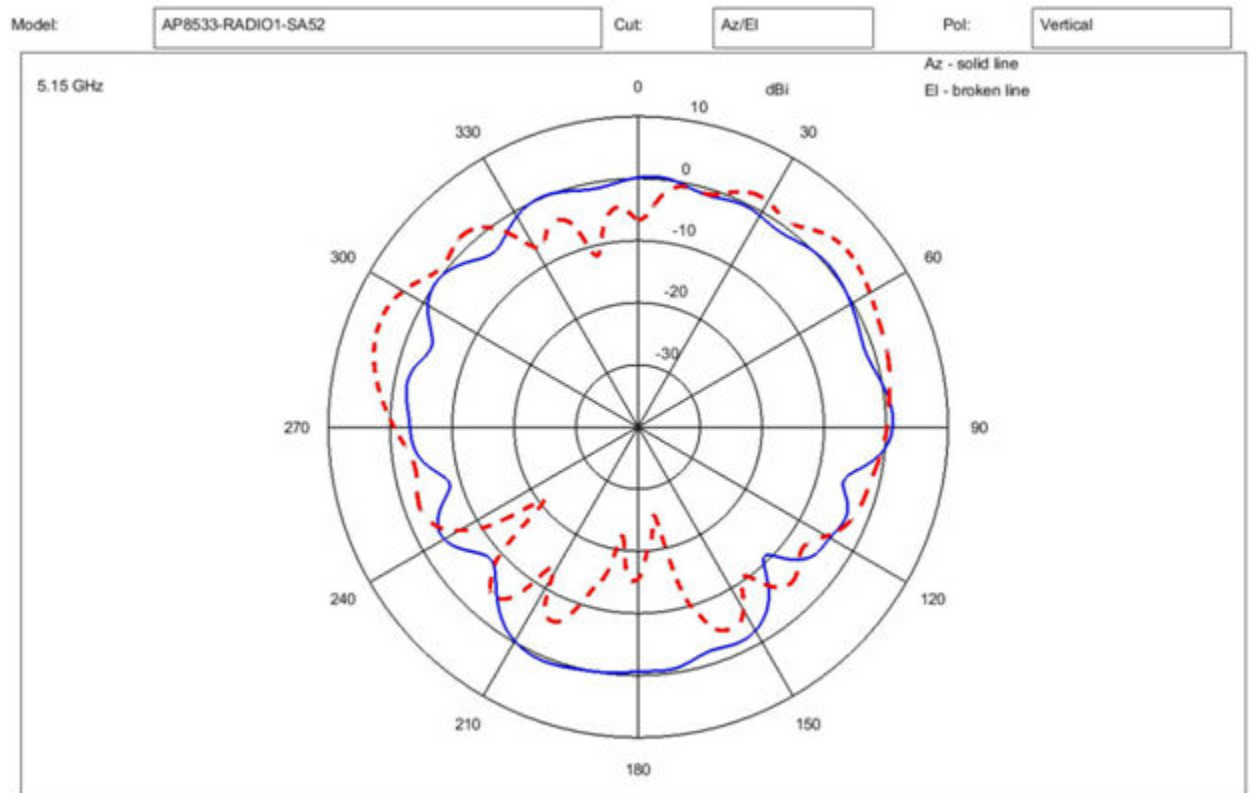
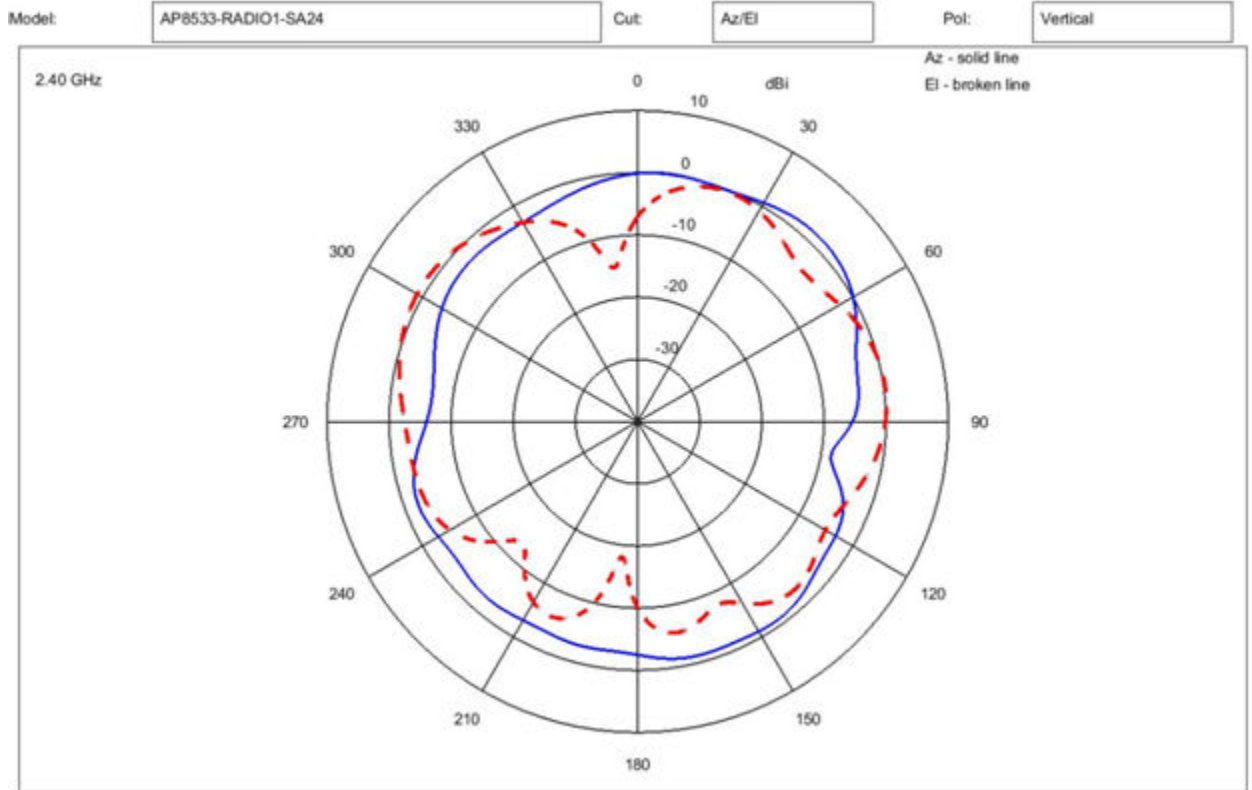

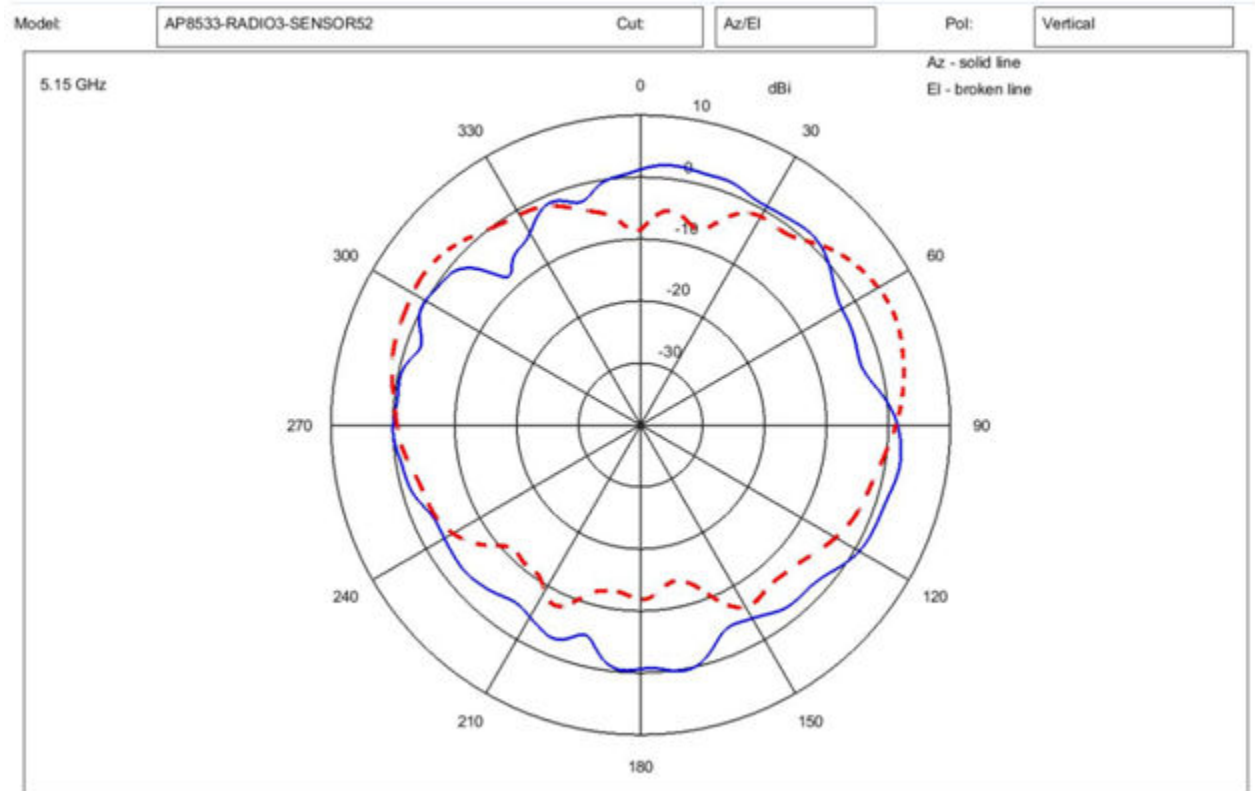
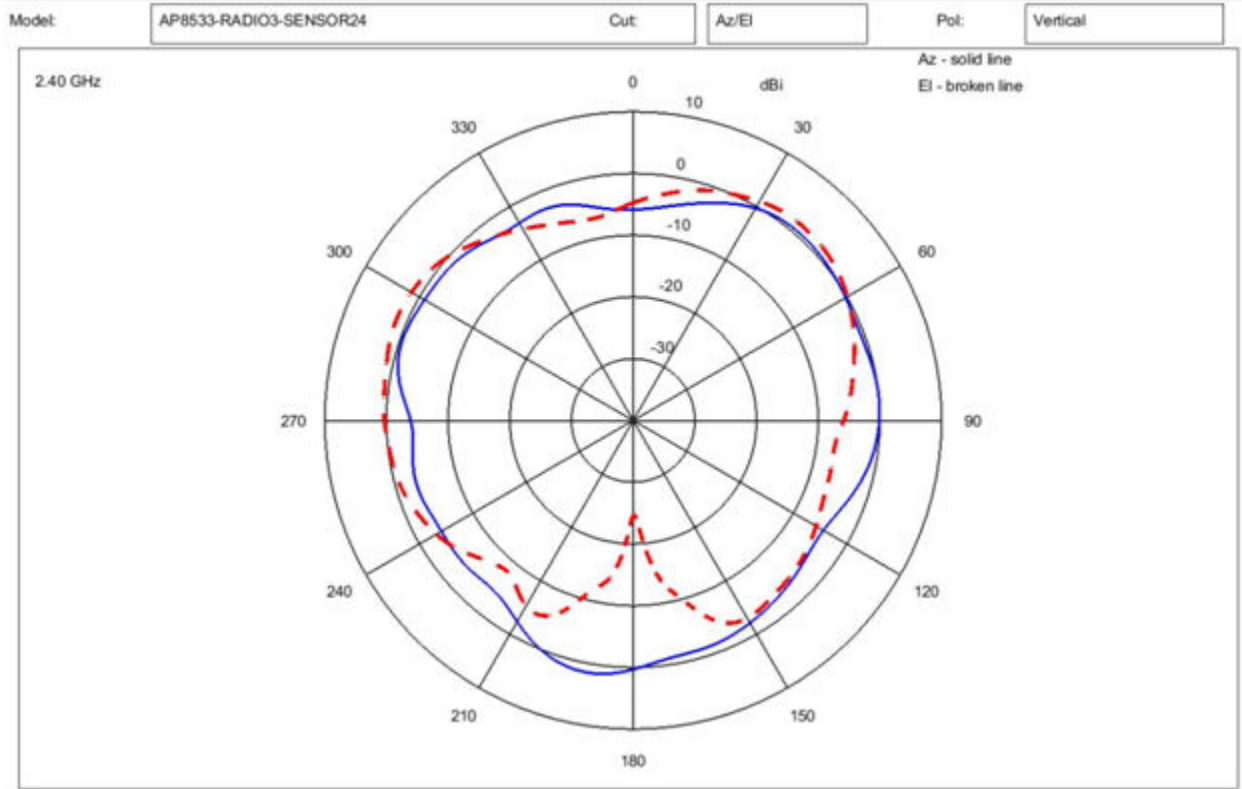

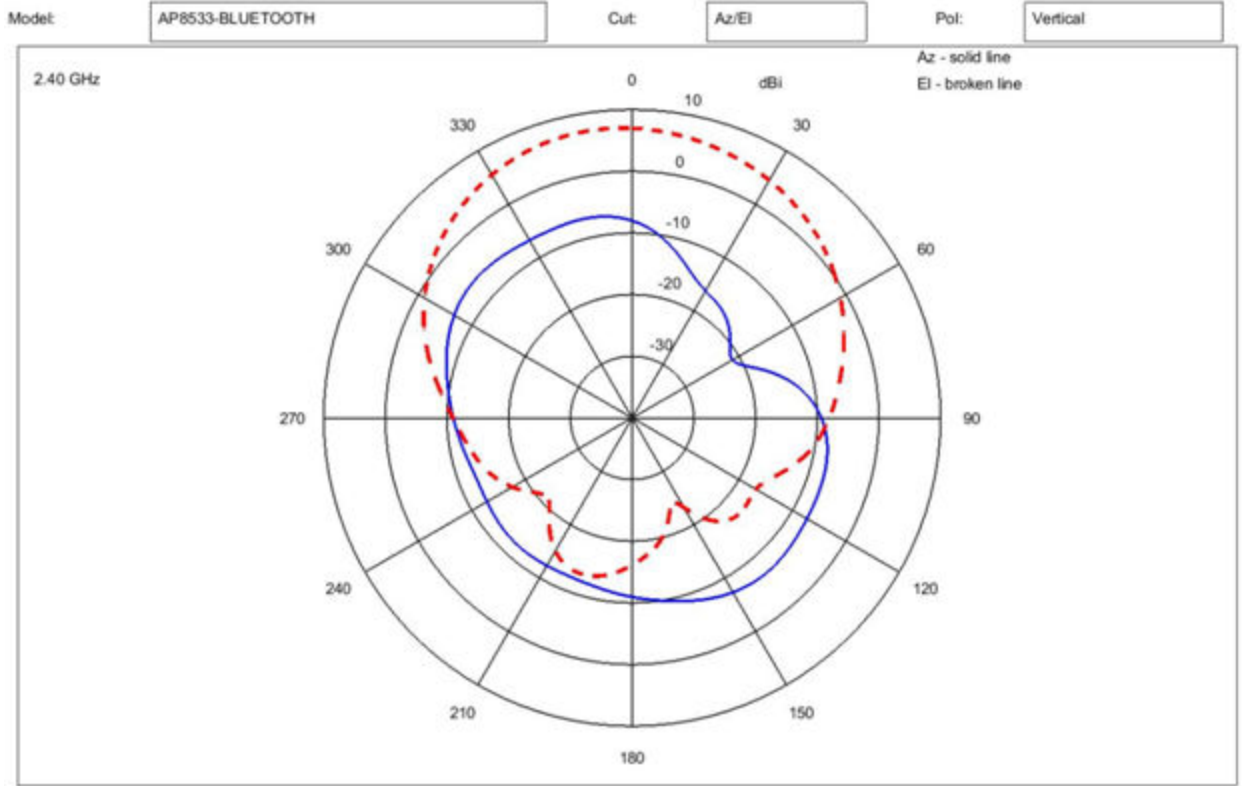

AP7602 Dual-Band Internal Antenna (2.4/5 GHz)



Type	AP7602 Dual-Band Internal Antenna
Frequency (MHz)	2400-2500/5000-6000
Max gain (dBi)	- 4.0/6.0
Elevation gain (dBi)	N/A
Polarization	Linear, Vertical
Azimuth beam width (degrees)	110
Elevation beam width (degrees)	60
Front to back ratio (dB)	15

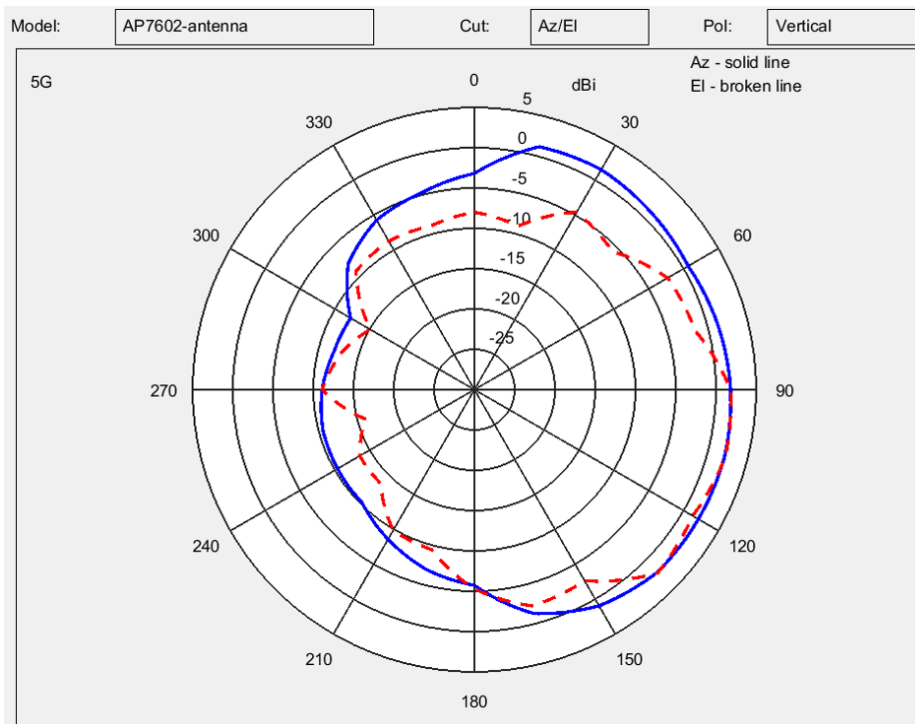
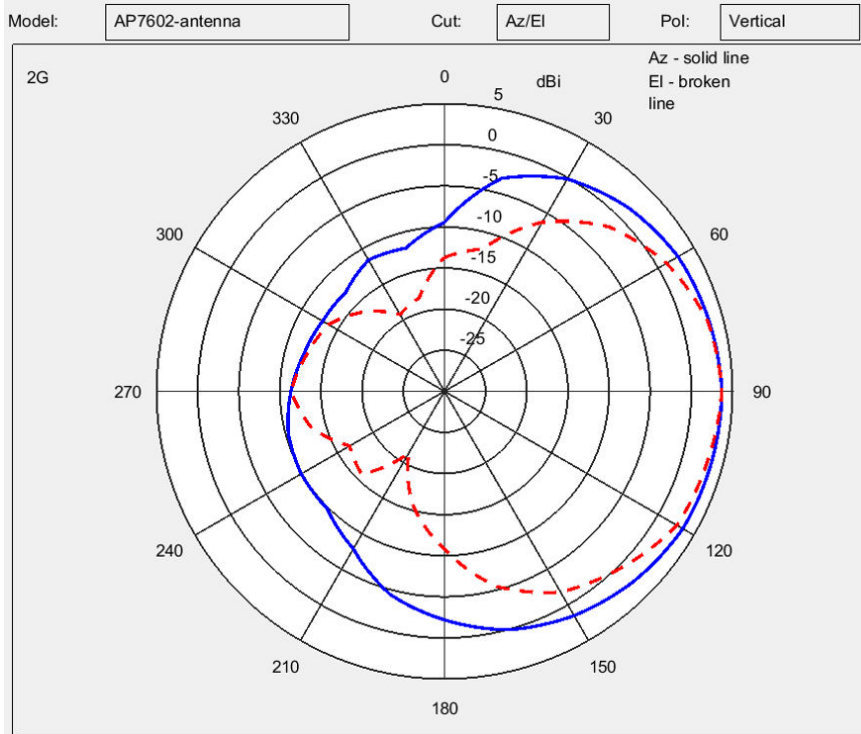

AP7612 Dual-Band Internal Antenna (2.4/5 GHz)

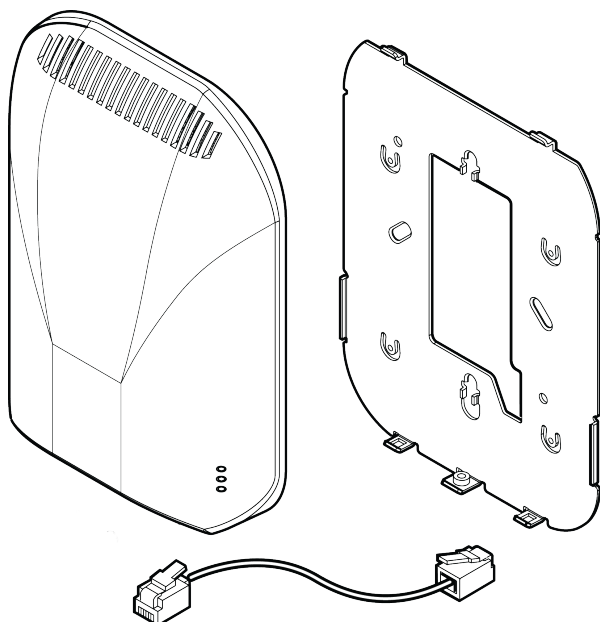

Table 3: Wi-Fi Radio

Type	Dipole
Frequency (MHz)	2400-2500/5150-5900
Max gain (dBi)	5.4 / 8.5
Polarization	Linear, Vertical
Azimuth beam width (degrees)	120
Elevation beam width (degrees)	120
Antenna Plenum Rated	No
Outdoor Rated	No
Weight	No
Storage Temp Range (°C)	-10 to +70
Operation Temp Range (°C)	0 to 40

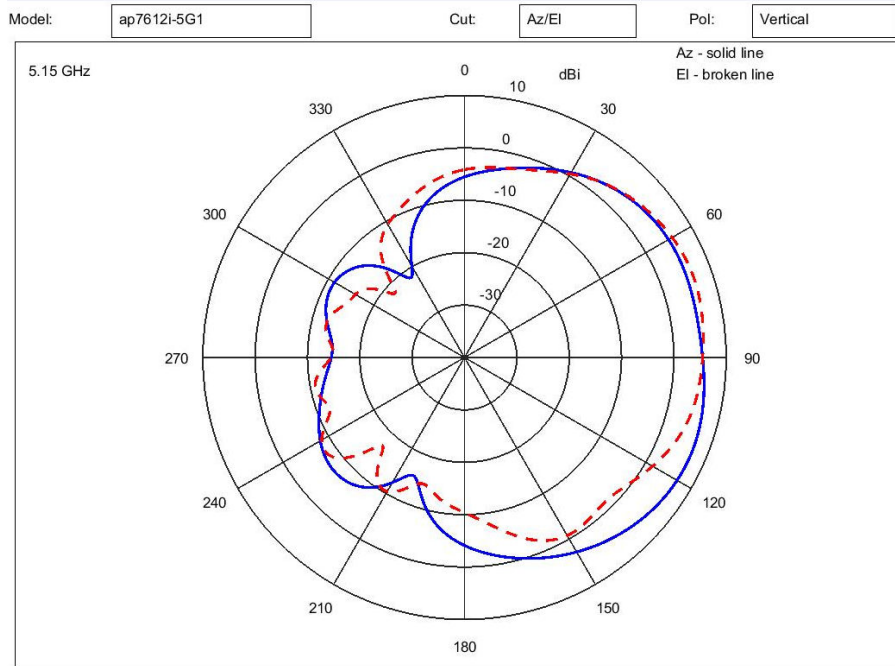
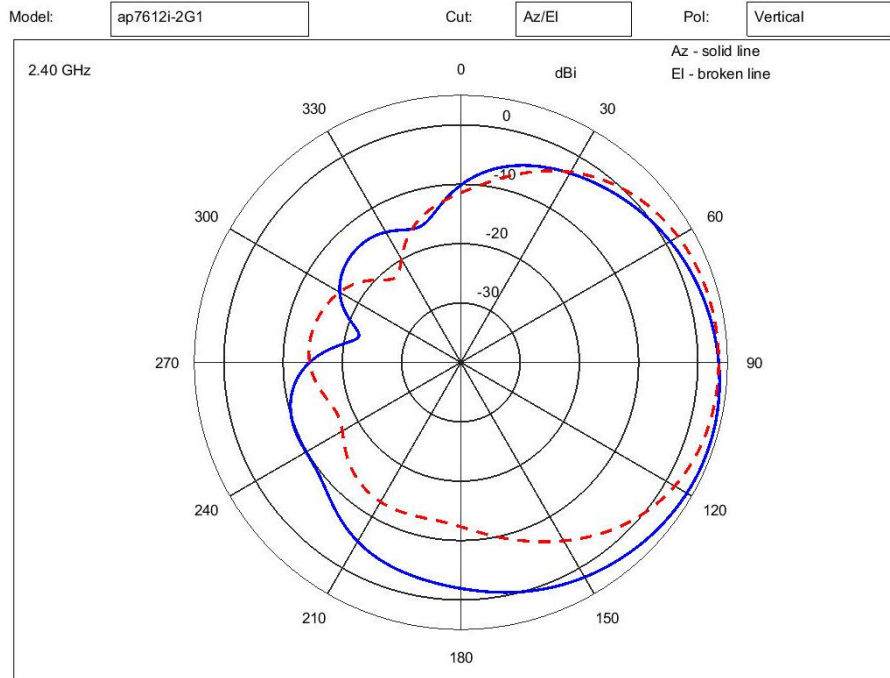
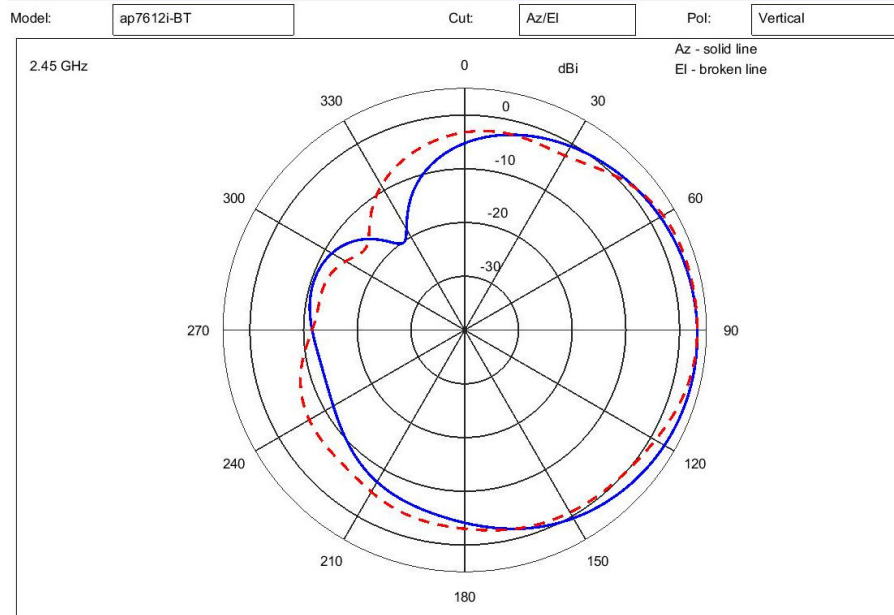

Table 4: BLE Radio Radio

Type	Dipole
Frequency (MHz)	2400-2500
Max gain (dBi)	3.7
Polarization	Linear, Horizontal

Table 4: BLE Radio Radio (continued)

Azimuth beam width (degrees)	140
Elevation beam width (degrees)	140
Antenna Plenum Rated	No
Outdoor Rated	No
Weight	No
Storage Temp Range (°C)	-10 to +70
Operation Temp Range (°C)	0 to 40



AP-7632i Dual-Band Internal Antenna (2.4/5 GHz)

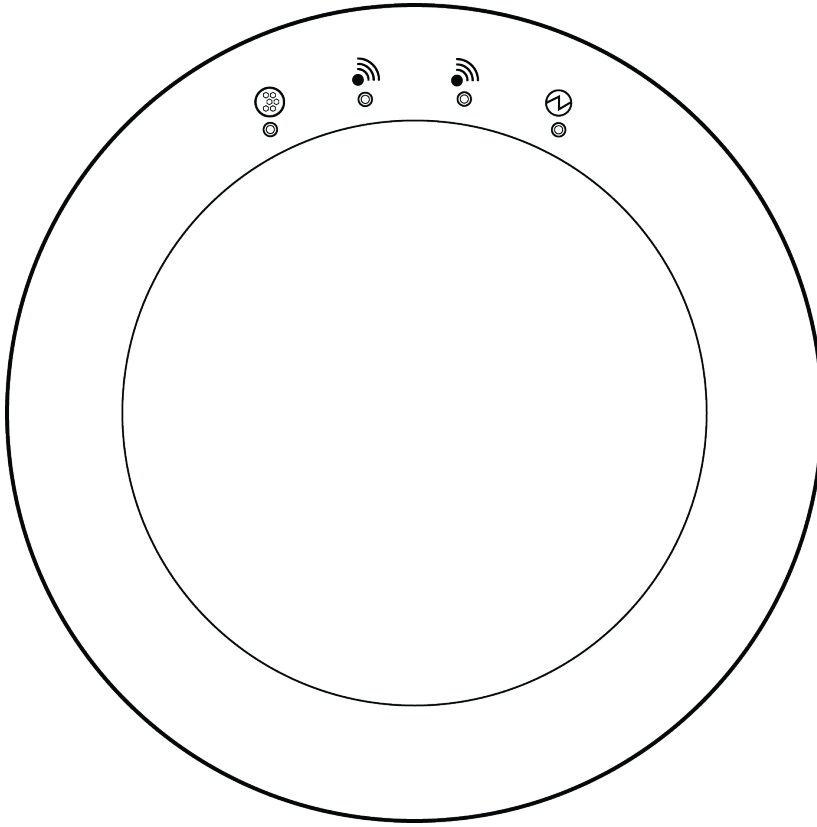

Table 5: Wi-Fi Radio

Type	Dipole
Frequency (MHz)	2400-2500/5150-5900
Max gain (dBi)	4.3/ 5.3
Polarization	Linear, Vertical
Azimuth beam width (degrees)	360
Elevation beam width (degrees)	330
Antenna Plenum Rated	No
Outdoor Rated	No

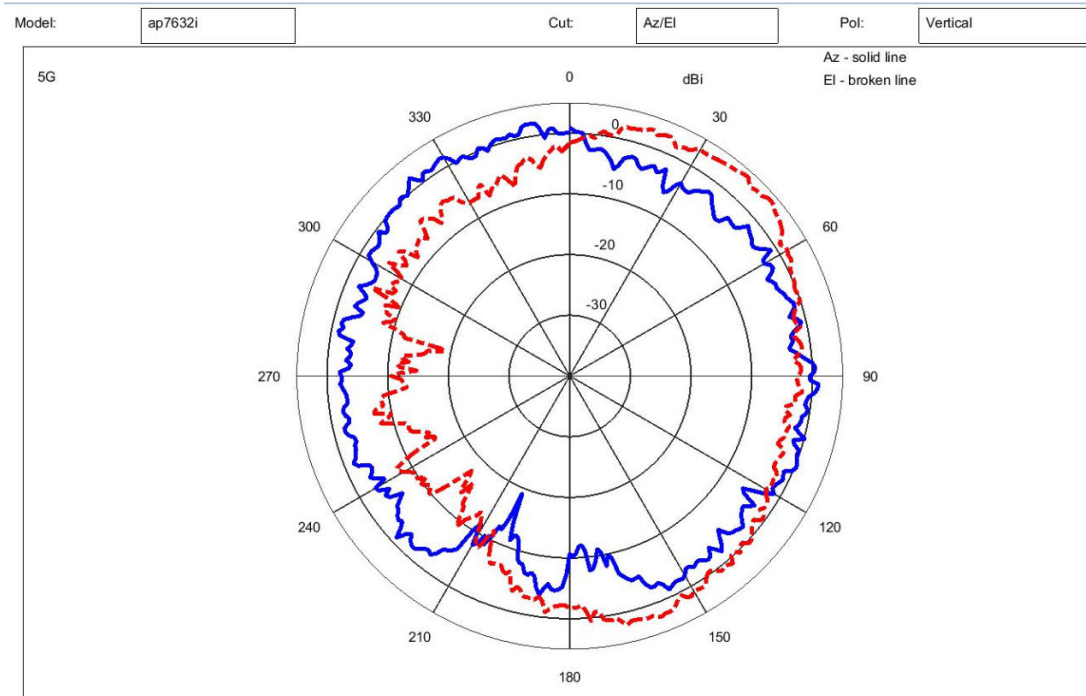
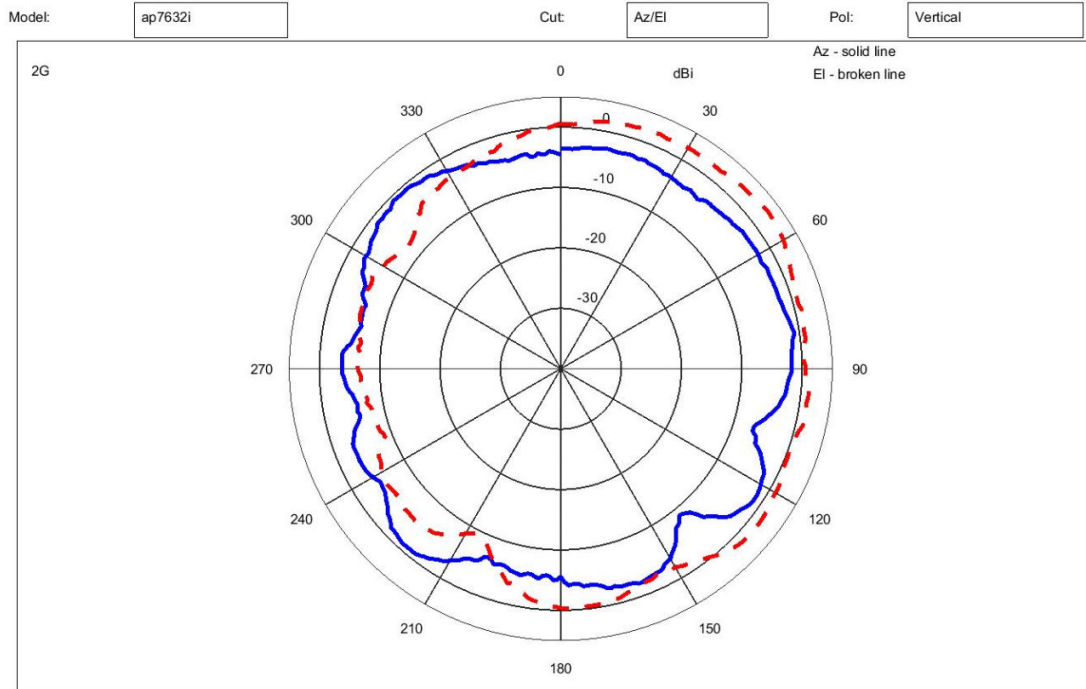
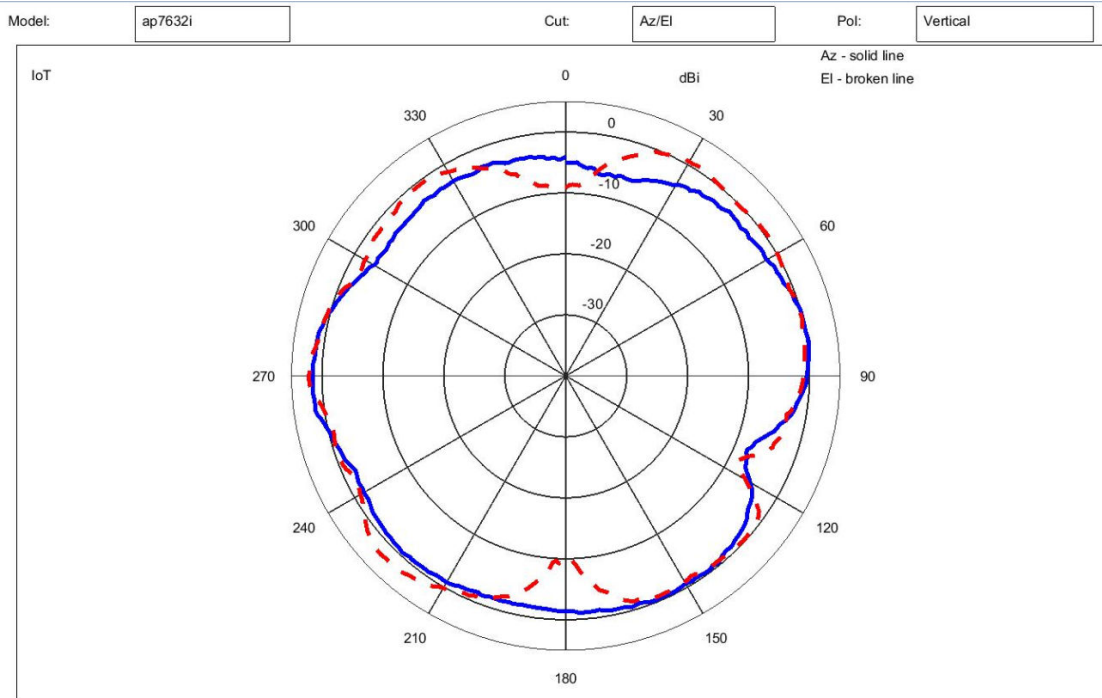

Table 6: IoT Radio

Type	Dipole
Frequency (MHz)	2400-2500
Max gain (dBi)	3.5

Table 6: IoT Radio (continued)

Polarization	Linear, Vertical
Azimuth beam width (degrees)	360
Elevation beam width (degrees)	330
Antenna Plenum Rated	No
Outdoor Rated	No



AP7662i Dual-Band Internal Antenna (2.4/4.9/5 GHz)

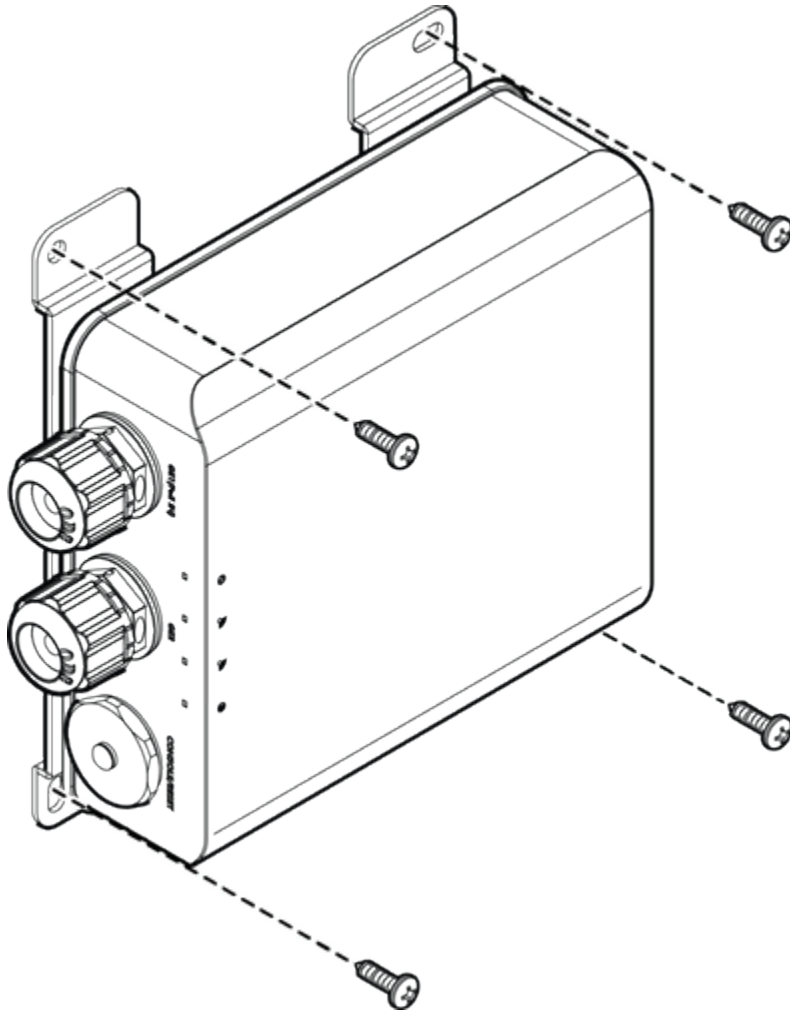

Table 7: Wi-Fi Radio

Type	Dipole
Frequency (MHz)	2400-2500/4900-5900
Max gain (dBi)	4.1 / 6.2
Polarization	Linear, Vertical
Azimuth beam width (degrees)	360
Elevation beam width (degrees)	180
Antenna Plenum Rated	Yes
Outdoor Rated	Yes

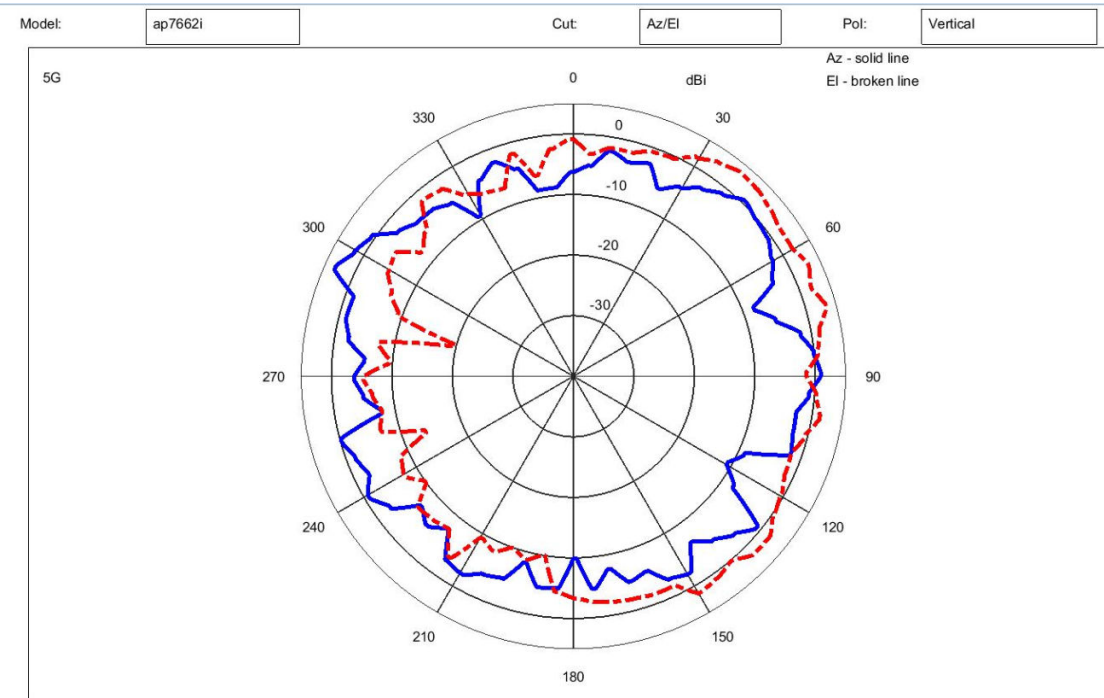
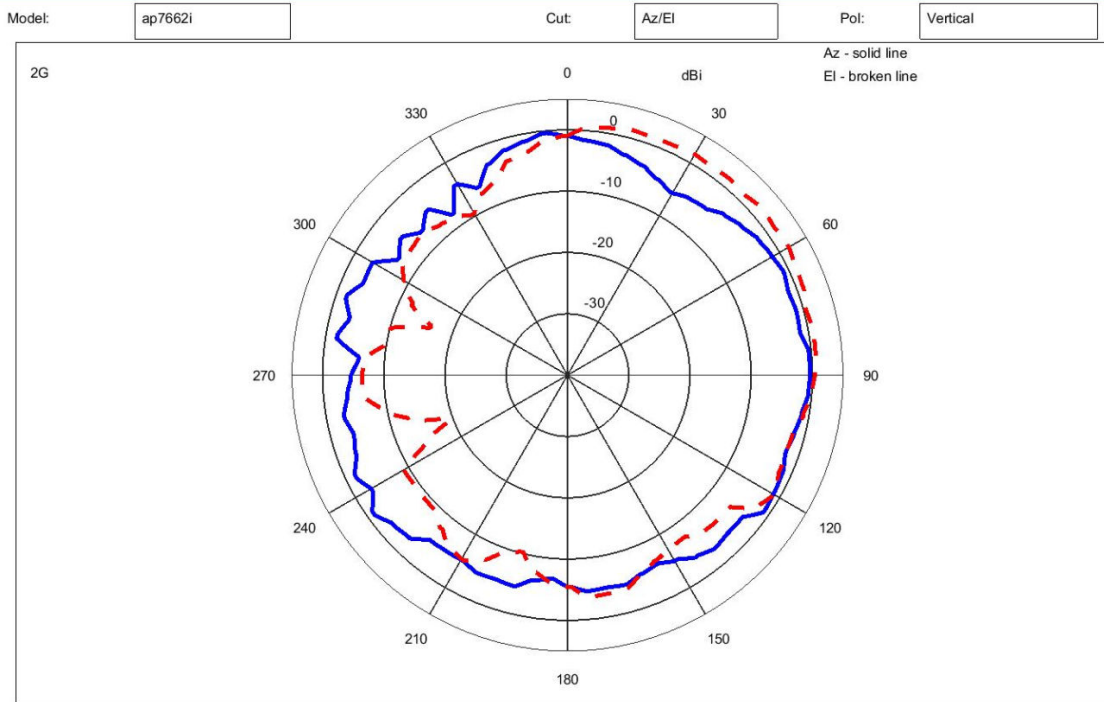
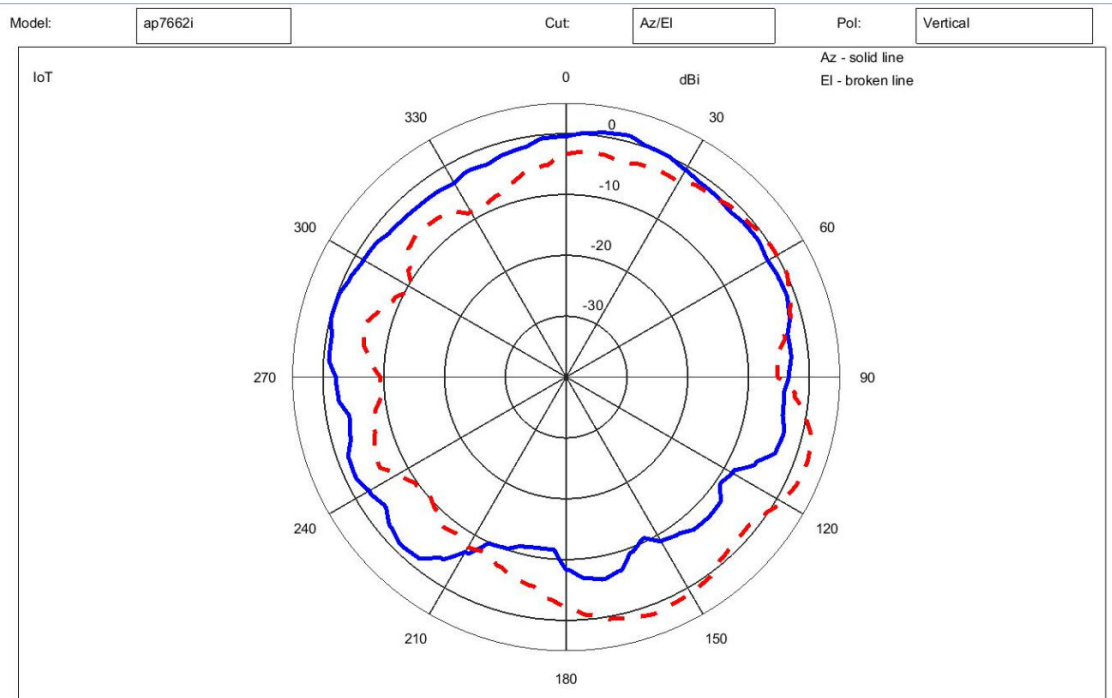

Table 8: IoT Radio

Type	Dipole
Frequency (MHz)	2400-2500
Max gain (dBi)	3.5

Table 8: IoT Radio (continued)

Polarization	Linear, Vertical
Azimuth beam width (degrees)	360
Elevation beam width (degrees)	180
Antenna Plenum Rated	Yes
Outdoor Rated	Yes



AP7622 Dual-Band Internal Antenna (2.4/5 GHz)



Type	AP7622 Dual-Band Internal Antenna
Frequency (MHz)	2400-2500/5000-6000
Max gain (dBi)	- 3.6/5.8
Elevation gain (dBi)	N/A
Polarization	Linear, Vertical
Azimuth beam width (degrees)	360
Elevation beam width (degrees)	160

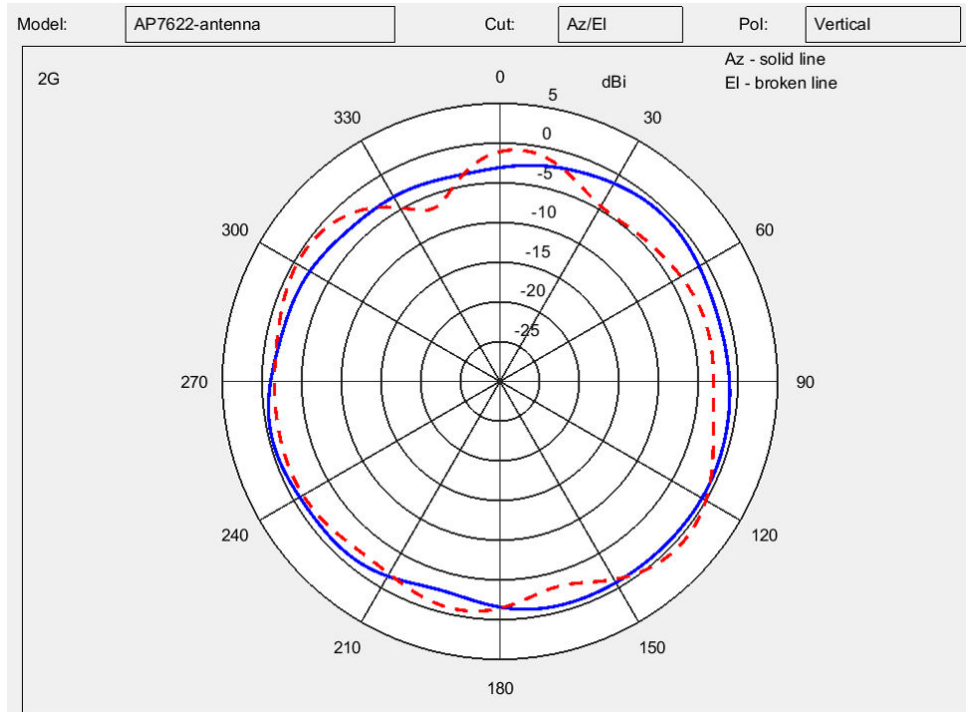

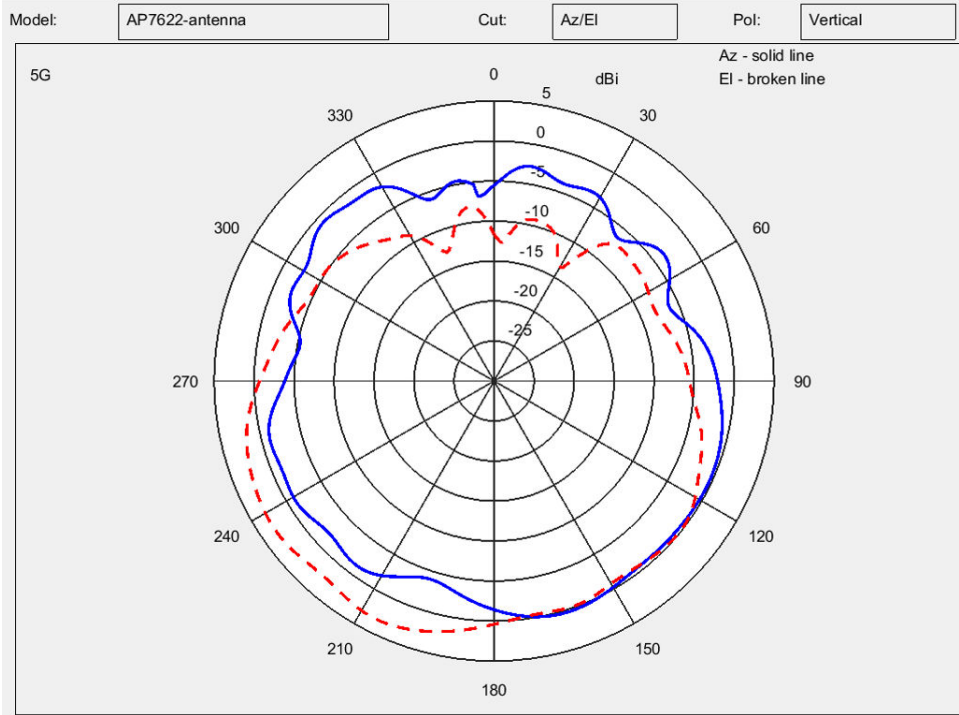

ML-2452-PTA4M4-036, 4-Port, Dual-Band, Ceiling Mount, Circular Omni Array (4 V-Pol ports)

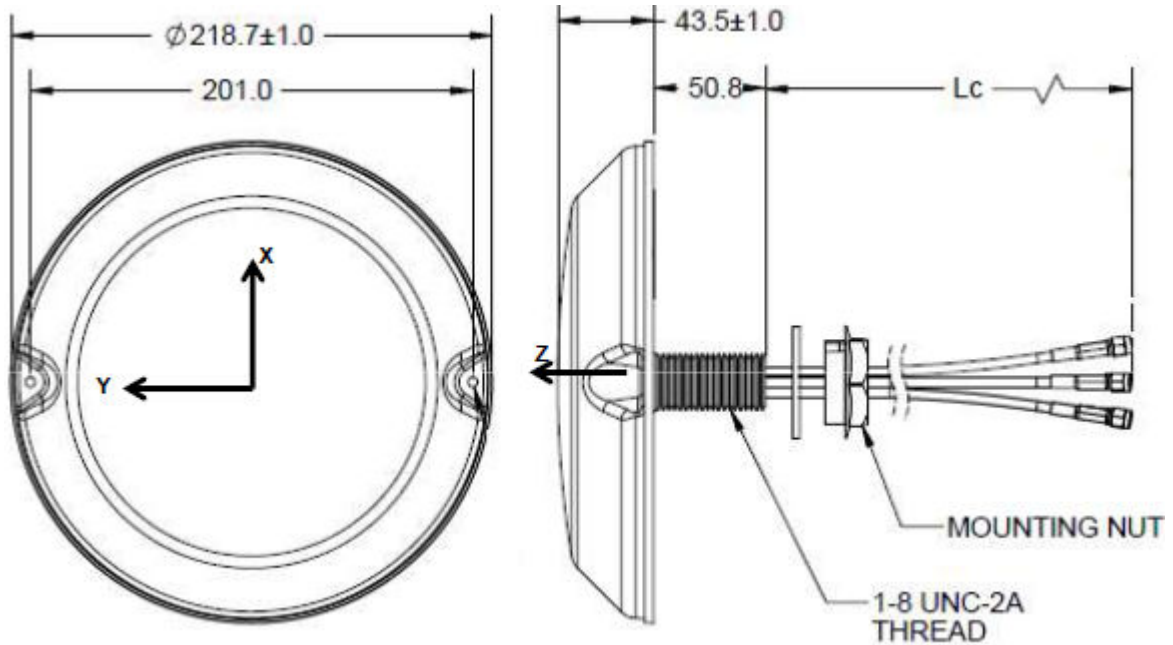

Type	Omni
Frequency	2400-2500, 5150-5875 MHz
Max Gain (dBi)	5.0/6.6 (2.4GHz/5GHz)

Polarization	Linear, Omnidirectional
Azimuth 3 dB Beamwidth:	360, 360
Elevation 3 dB Beamwidth:	70, 50
Cable Length (inches)	36
Cable Type	RG-58
Antenna Plenum Rated	Yes
Cable Plenum Rated	Yes
Outdoor Rated	No
Weight (lbs)	1.1
Storage Temp Range (C)	-30°/70°
Operation Temp Range (C)	-30°/70°

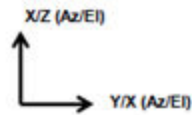
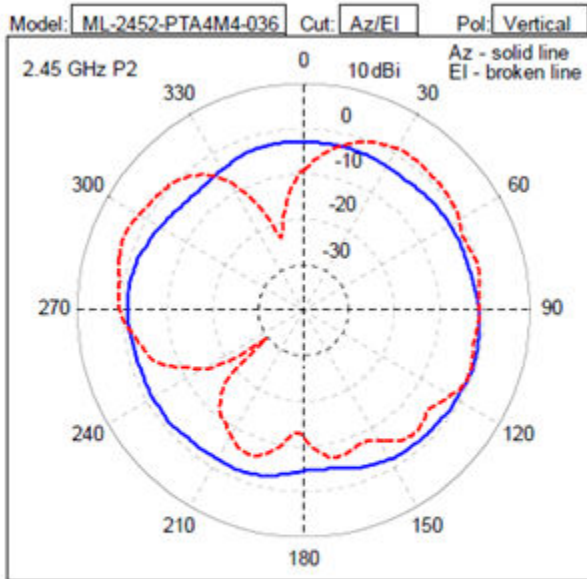
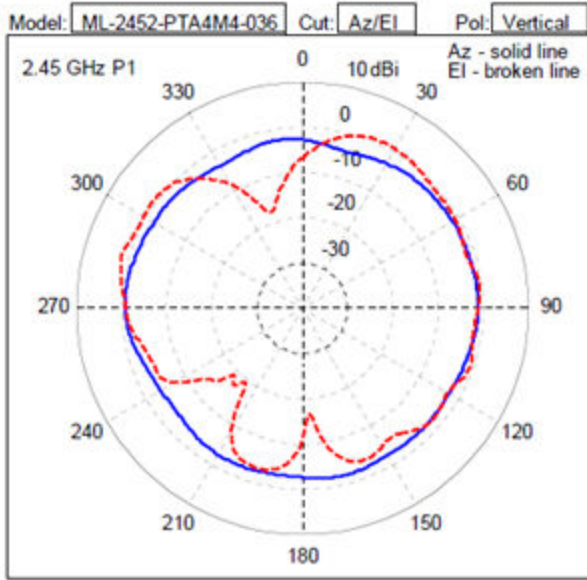

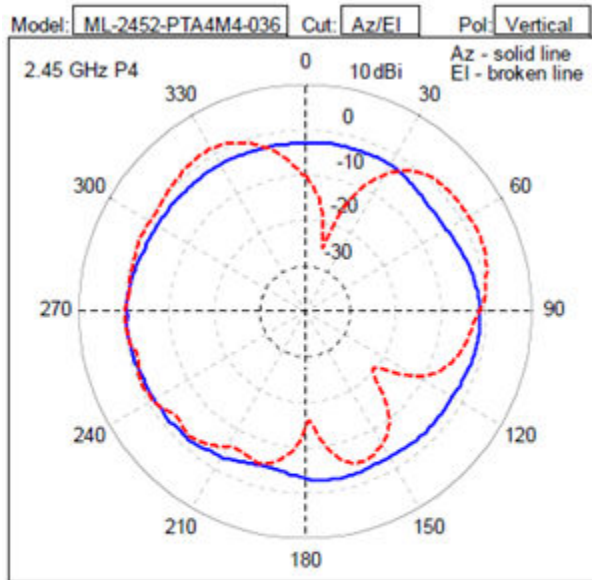
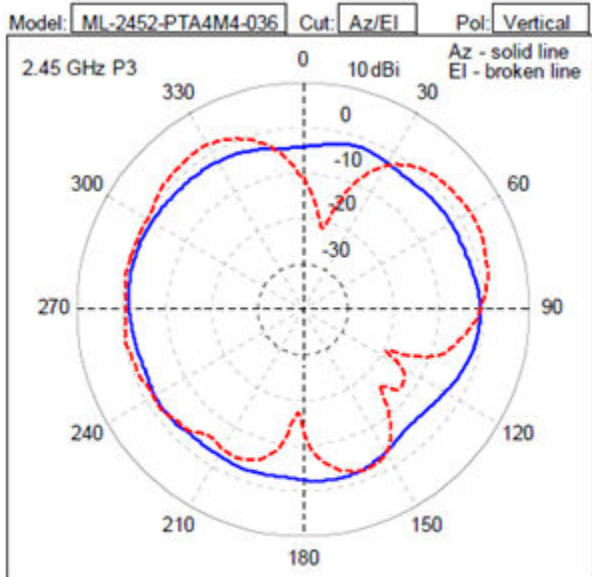

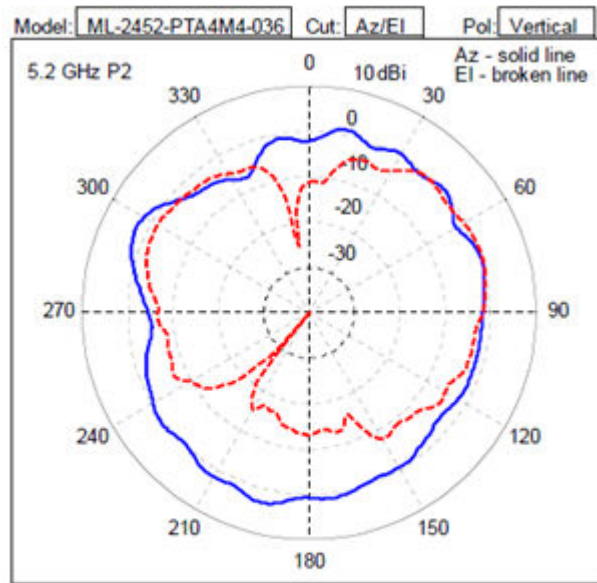
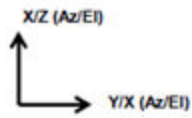
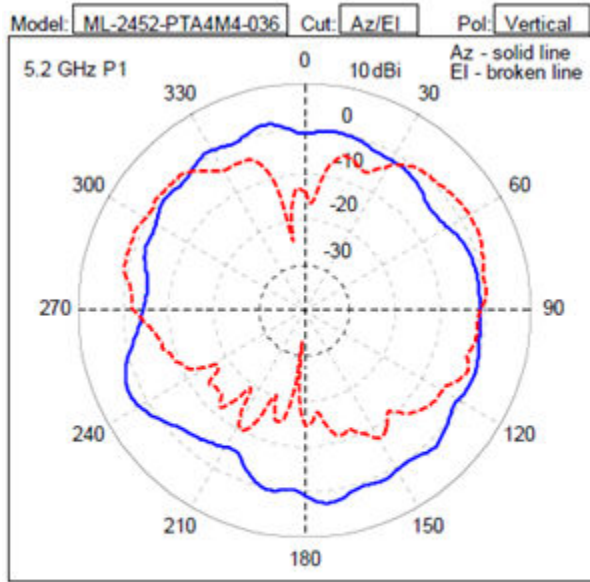

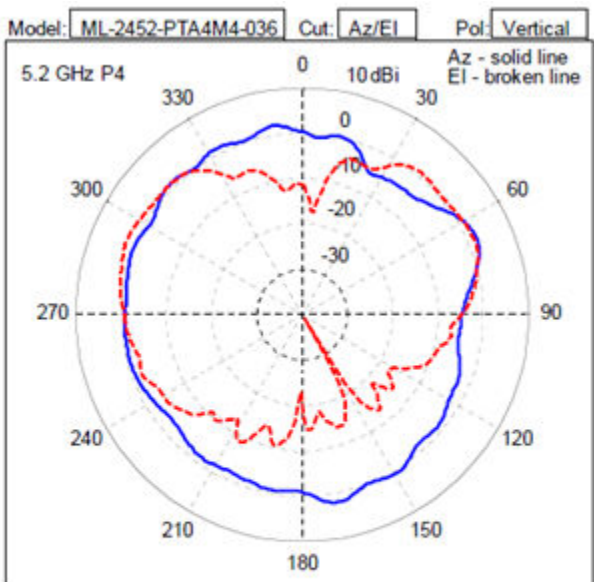
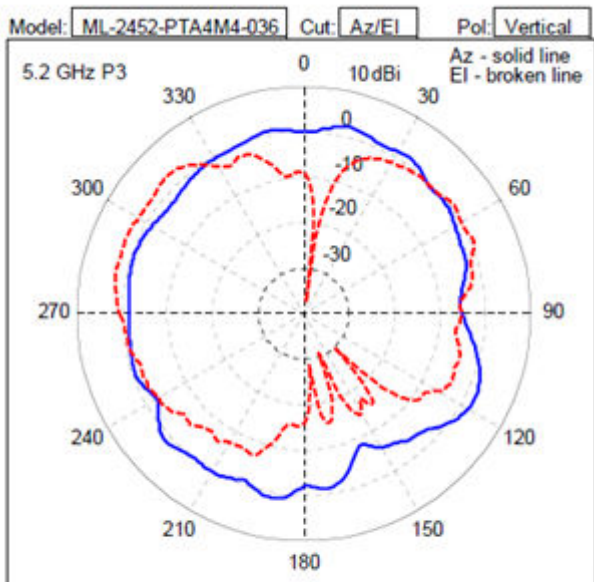

ML-2452-SEC6M4-036, Dual Polarized, Dual Band Wide Beam Directional Antenna, 32 Inch Cable, RPSMA-Male Connector

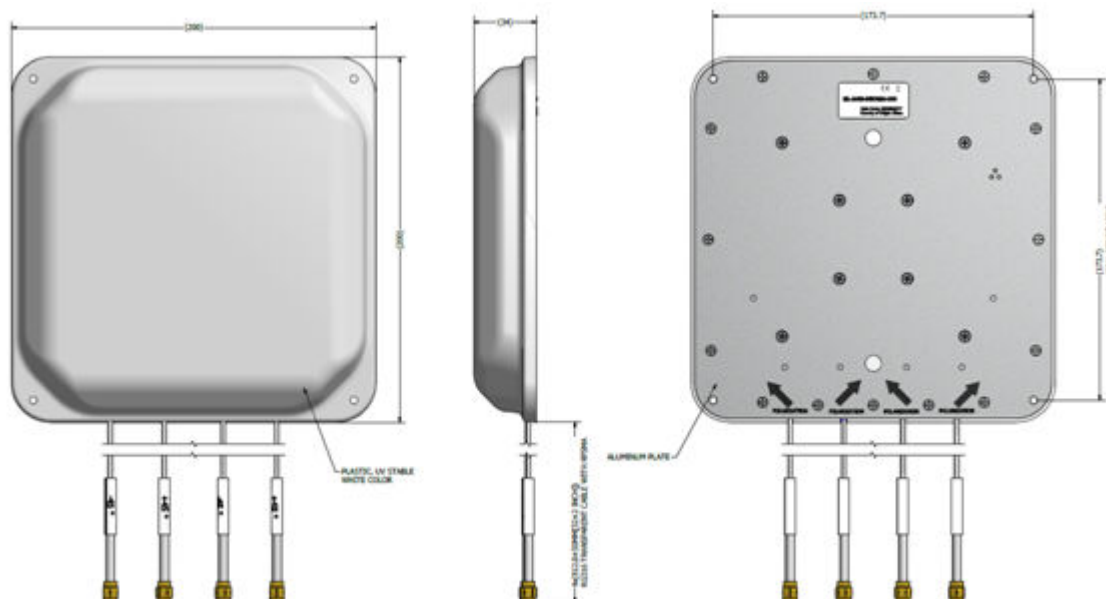

Type	Sector
Frequency	2400-2500, 5150-5850 MHz
Max Gain (dBi)	6.92/7.23 (2.4GHz/5GHz)
Elevation Gain (dBi)	3.978
Polarization	Vertical, Dual Slant
Azimuth 3 dB Beamwidth:	100, 80
Elevation 3 dB Beamwidth:	80, 65
Cable Length (inches)	32
Cable Type	RG316
Antenna Plenum Rated	Yes
Cable Plenum Rated	Yes
Outdoor Rated	Yes
Weight (kg)	.45 kg
Storage Temp Range (C)	-40°/70°
Operation Temp Range (C)	-40°/70°

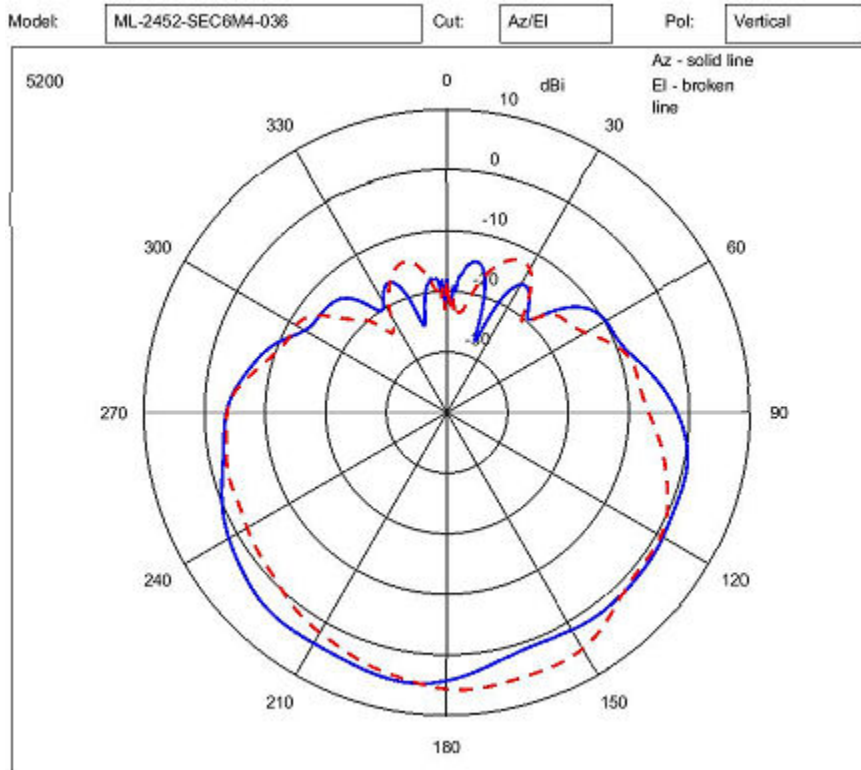
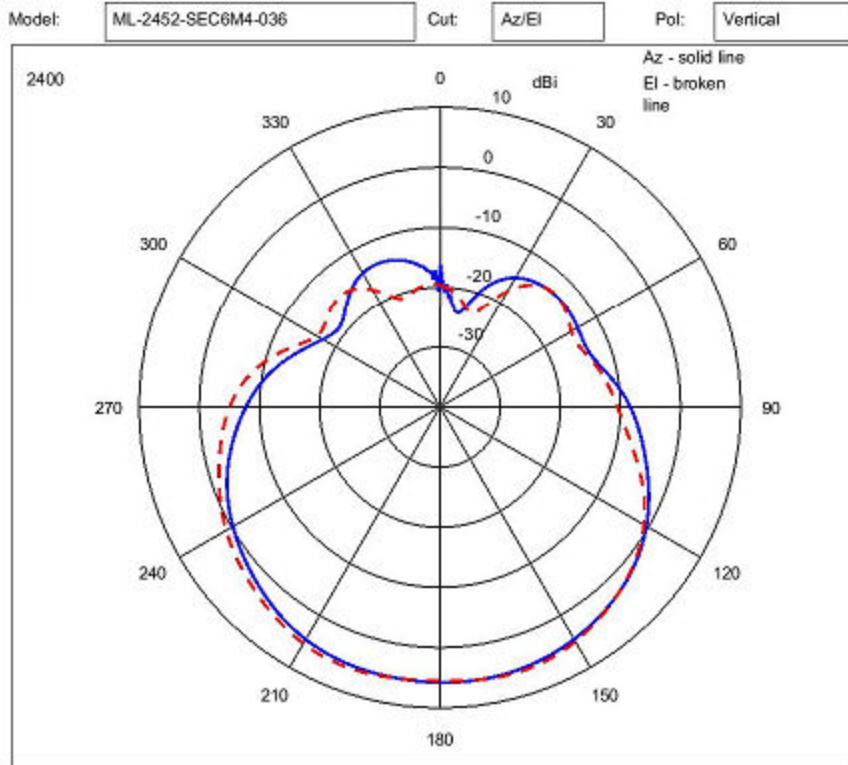

ML-2452-HPA6M4-S36, Dual Band, Four Input Omni, 36 Inch Cable, RPSMA Connectors

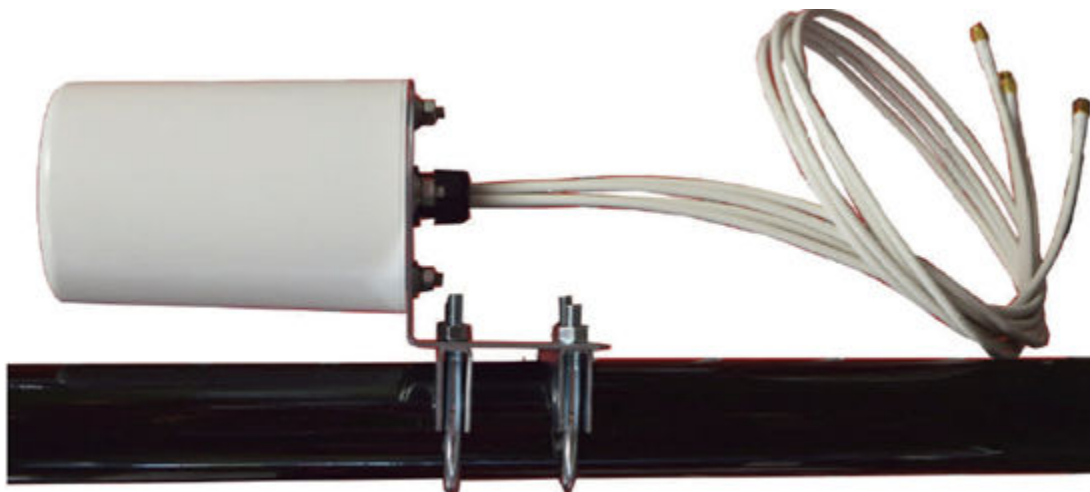

Type	Dipole
Frequency	2400-2500, 4900-5850 MHz
Max Gain (dBi)	6.0/6.0 (2.4GHz/5GHz)
Elevation Gain (dBi)	2.0
Polarization	Linear, Omnidirectional
Azimuth 3 dB Beamwidth:	360, 360
Elevation 3 dB Beamwidth:	50, 30
Cable Length (inches)	36
Cable Type	RG-58
Antenna Plenum Rated	No
Cable Plenum Rated	No
Outdoor Rated	Yes
Weight (kg)	.75 kg
Storage Temp Range (C)	-40°/70°
Operation Temp Range (C)	-40°/70°

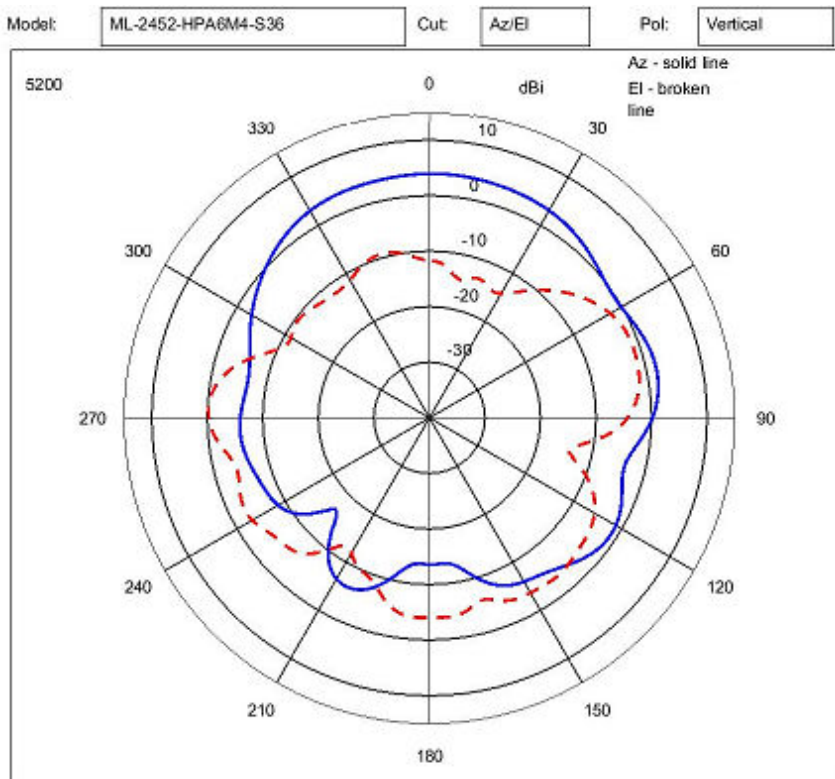
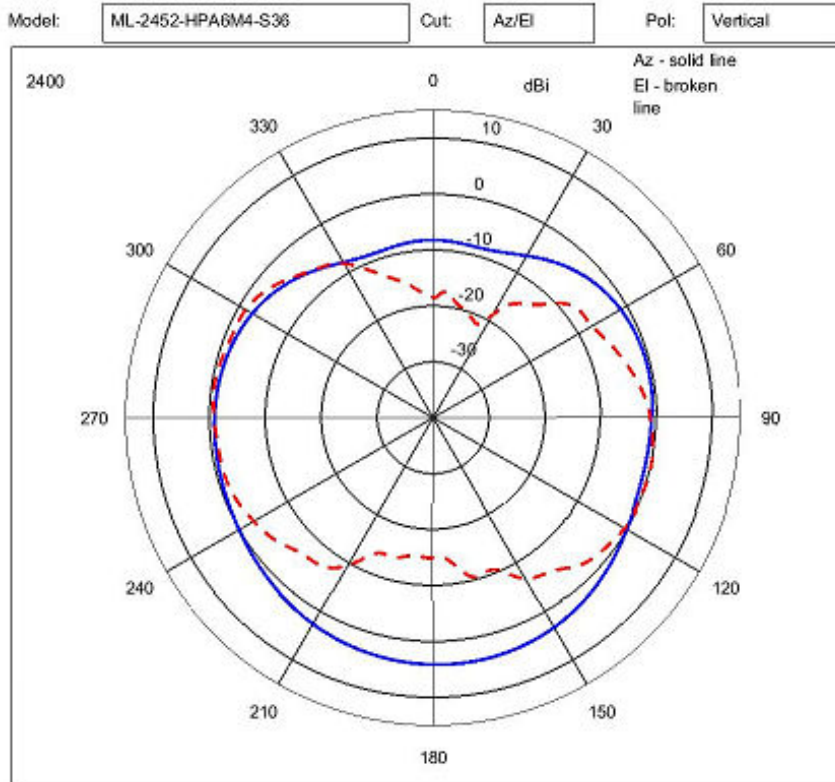

ML-2452-PNL6M4-N36 Dual Polarized, Dual Band Narrow Beam Directional Antenna, with 36 Inch Cable and N-Male Connector

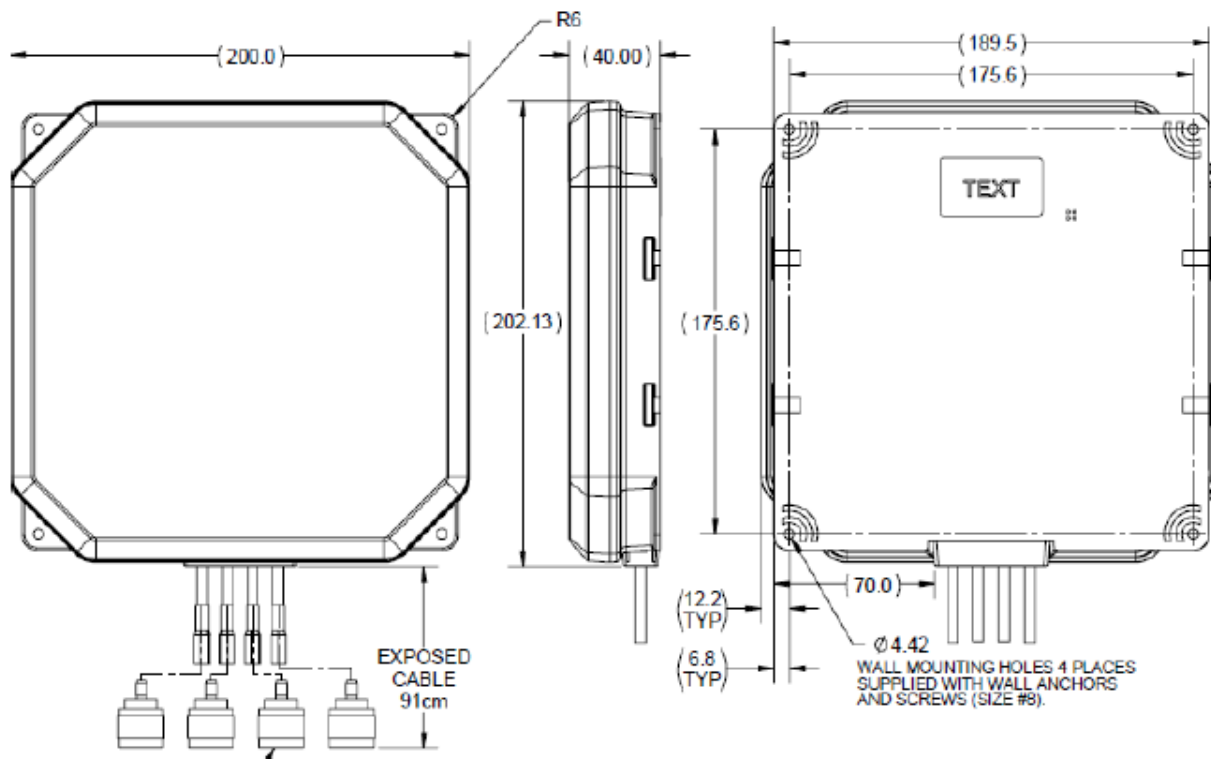

Type	Polarized-panel
Frequency (MHz)	2400-2500/4900-5858
Max Gain (dBi)	5.7/6.7/5.5 (2.4GHz/4.9 GHz/5 GHz)
Polarization	Linear slanted vertical Port A: + 45 degree Port B: -45 degree Port C: +45 degree Port D: -45 degree
Max UNII-1 Elevation Gain (dBi)	5.48
Azimuth 3 dB Beamwidth:	- 90
Elevation 3 dB Beamwidth	- 100
Cable Length (in.)	30
Cable Type	Coaxial with N-type
Antenna Plenum Rated	Yes
Cable Plenum Rates	Yes
Outdoor Rated	Yes
Storage Temp Range (C)	-40 / +70
Operation Temp Range (C)	-40 / +70

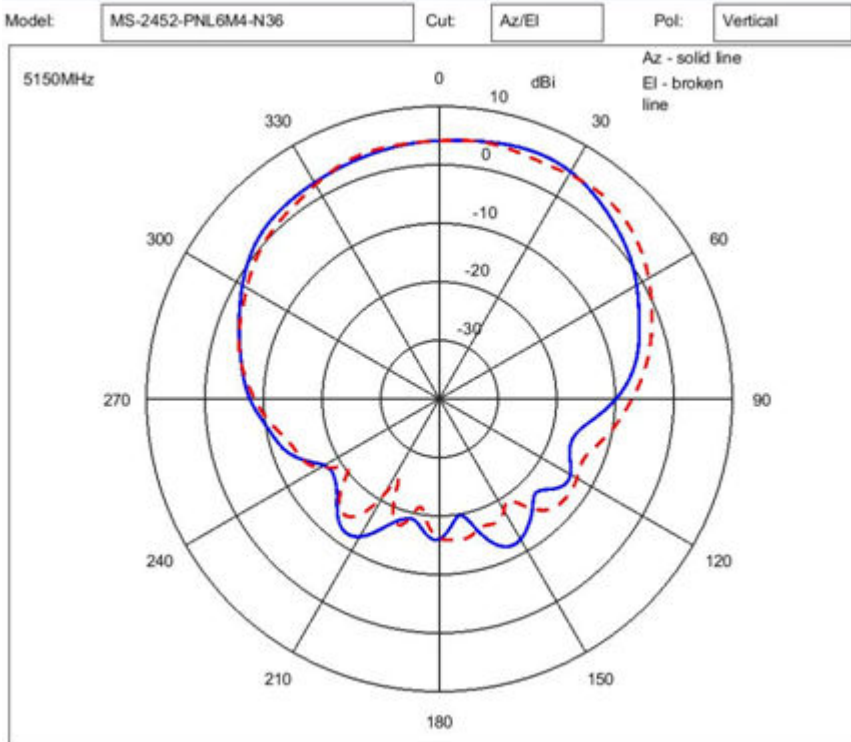
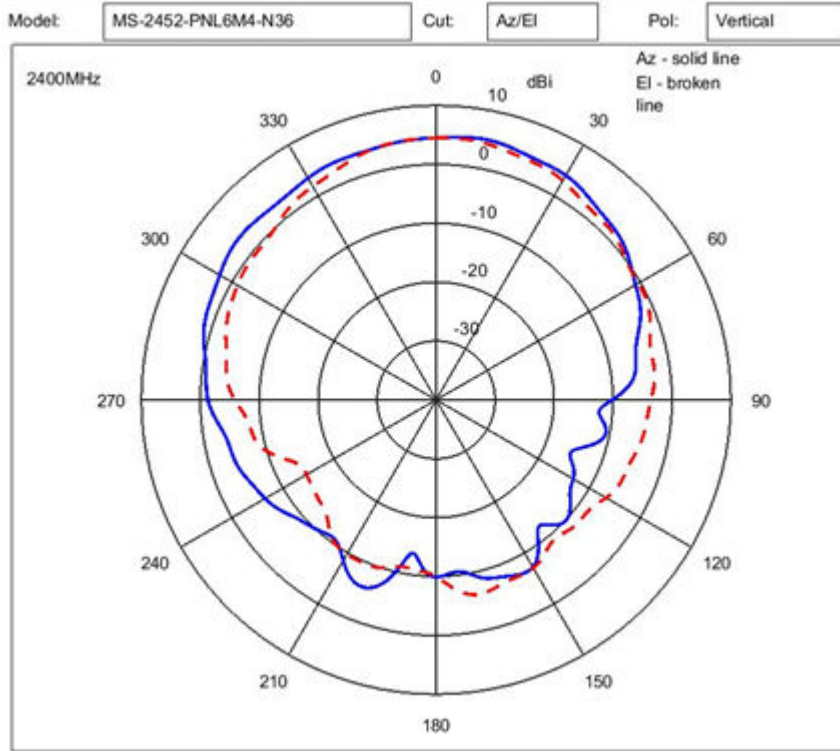

ML-2452-SEC6M4-N30 Dual Band Sector Antenna, with 30 Inch Cable and N Male Connectors

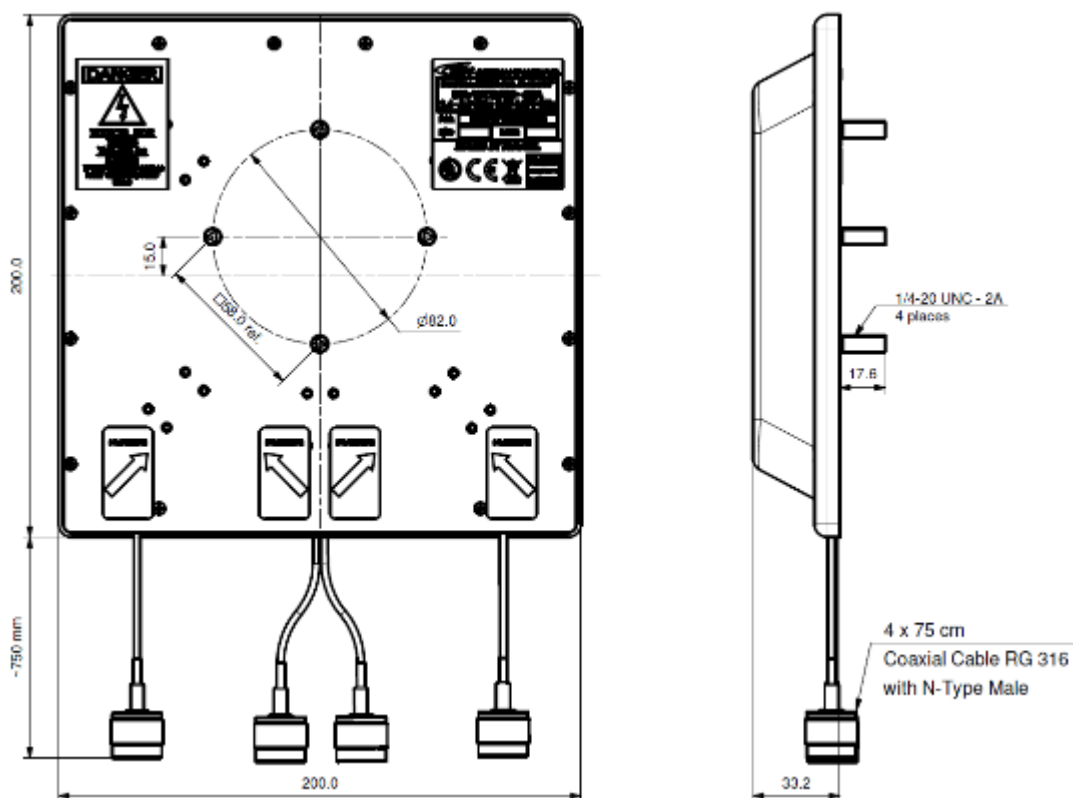

Type	Polarized-panel
Frequency	2400-2500, 5150-5850 MHz
Max Gain (dBi)	5.5/6 (2.4GHz/5 GHz)
Polarization	Linear slanted vertical Port A: + 45 degree Port B: -45 degree Port C: +45 degree Port D: -45 degree
Max UNII-1 Elevation Gain (dBi)	2.0
Azimuth Beamwidth (degree)	- 60
Elevation Beamwidth (degree)	- 60
Cable Length (in.)	30
Cable Type	Coaxial with N-type
Antenna Plenum Rated	Yes
Cable Plenum Rated	Yes
Outdoor Rates	Yes
Weight (lbs)	1

Storage Temp Range (C)	-40/+70
Operation Temp Range (C)	-40/+70

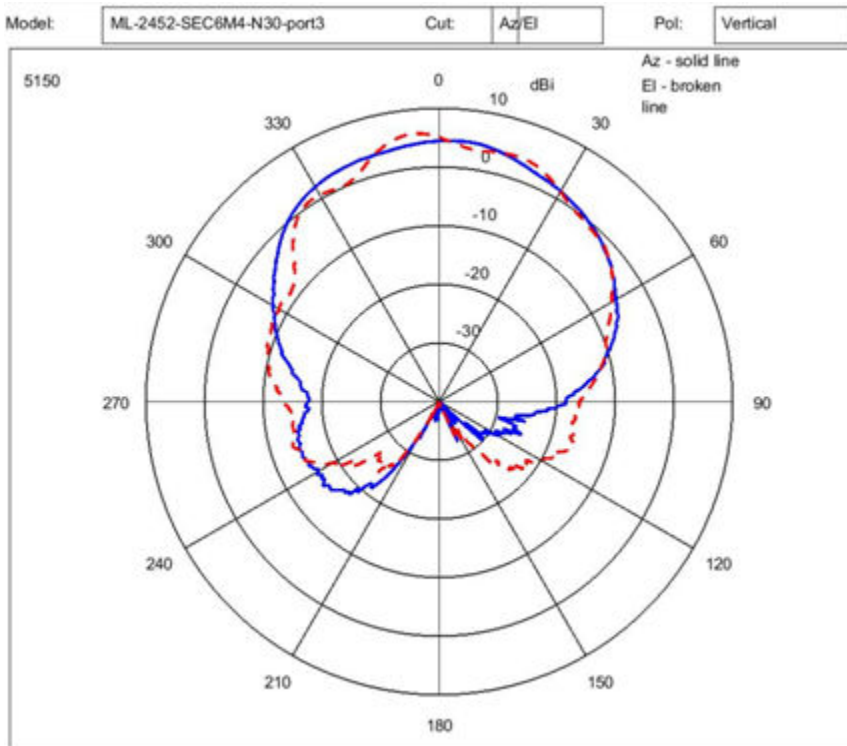
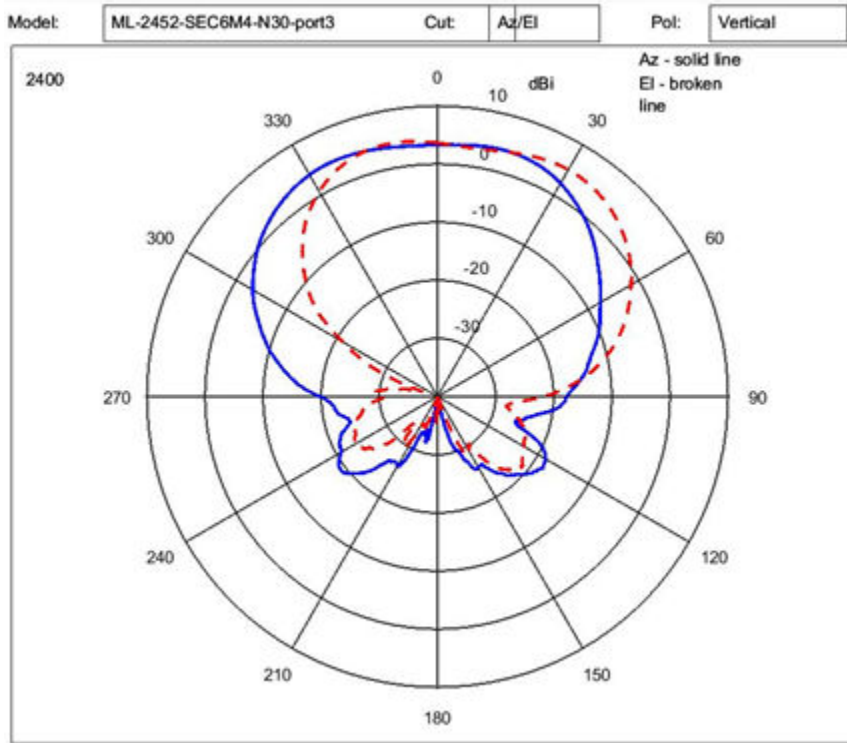

ML-2452-SEC6M4-N36 Dual Polarized Dual Band Wide Beam Directional Antenna, with 32 Inch Cable and N-Male Connector

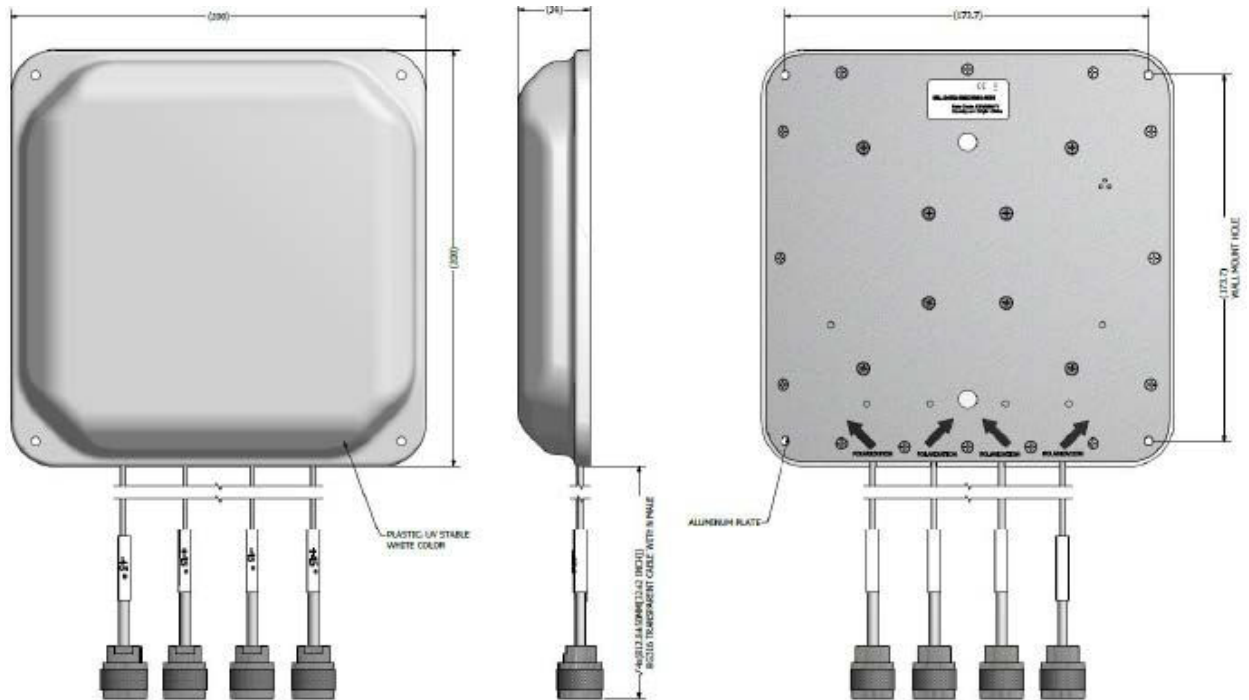

Type	Polarized-panel
Frequency	2400-2500, 5150-5875 MHz
Max Gain (dBi)	6.92/7.23 (2.4GHz/5 GHz)
Polarization	Linear slanted vertical Port A: + 45 degree Port B: -45 degree Port C: +45 degree Port D: -45 degree
Max UNII-1 Elevation Gain (dBi)	-1.2
Azimuth Beamwidth (degree)	- 100
Elevation Beamwidth (degree)	- 90
Cable Length (in.)	32
Cable Type	Coaxial with N-type
Antenna Plenum Rated	Yes
Cable Plenum Rated	Yes
Outdoor Rated	Yes
Weight (lbs)	1
Storage Temp Range (C)	-40/+70
Operation Temp Range (C)	-40/+70

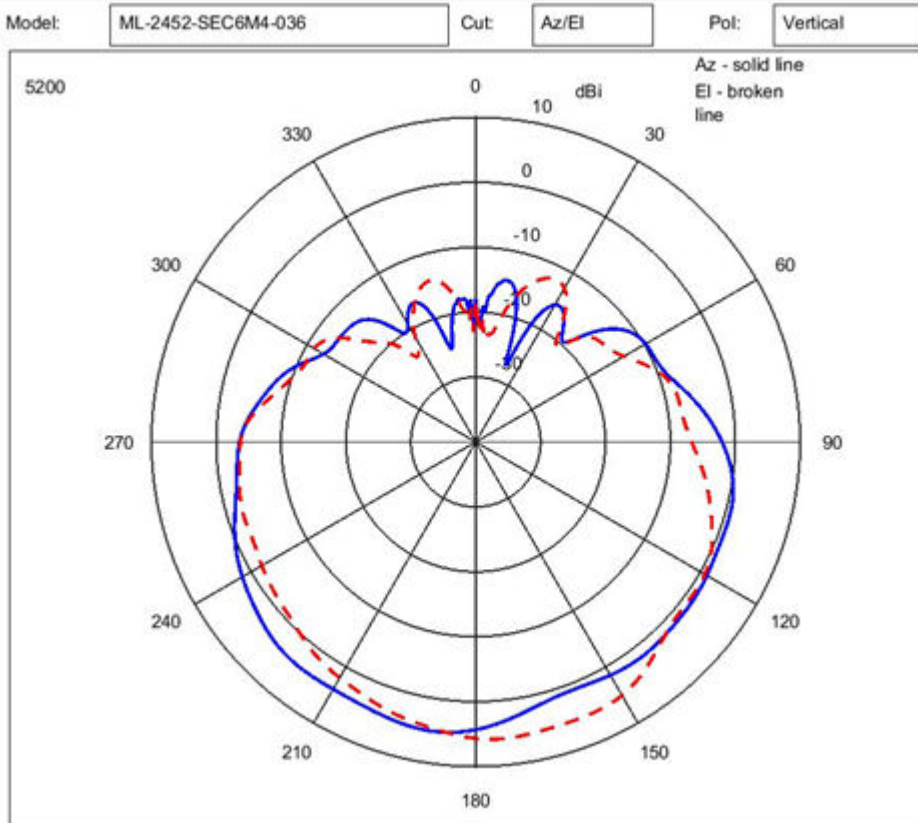
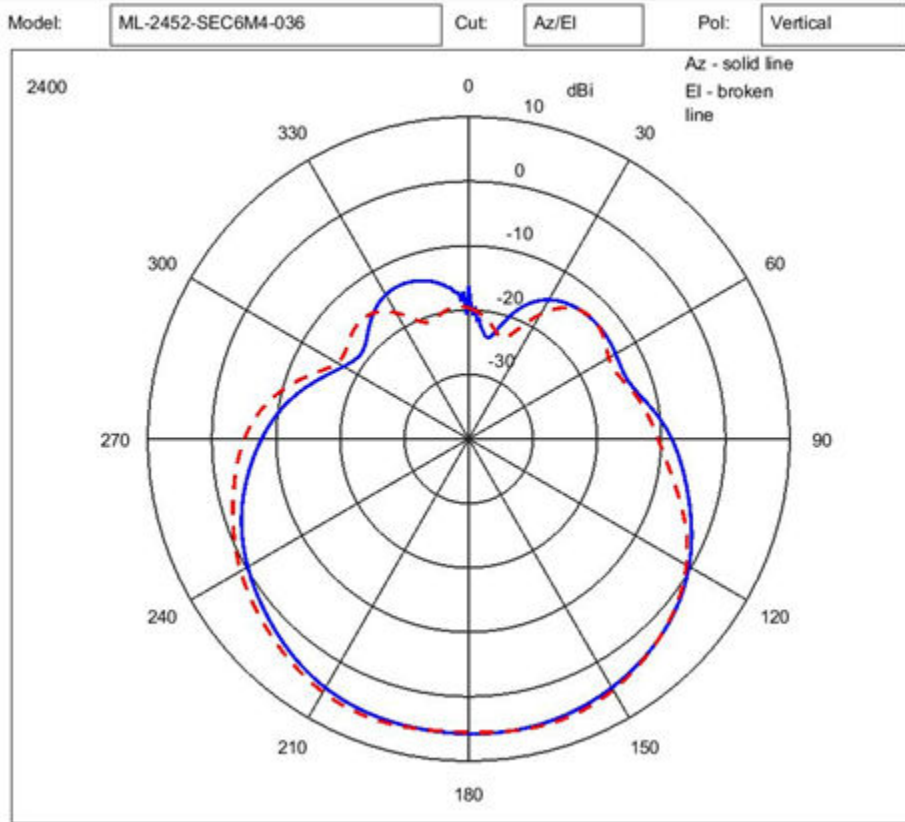

6 Antenna Cables

ML-1499-10JK-01R 10 ft. Low-Loss Coaxial Cable Jumper: N Male to N Male
ML-1499-25JK-01R 25 ft. Low-Loss Coaxial Cable Jumper: N Male to N Male with 2 Connector Seal Kits

Numerous cables are supported to suit your unique access point or access port deployment. Check the Support site periodically, as new cables will be added to this document as they are released.

ML-1499-10JK-01R 10 ft. Low-Loss Coaxial Cable Jumper: N Male to N Male

Type	Ultralink TL 93605
RF Connectors	N (m) to N (m)
Cable Attenuation (dB)	2.0 @ 2.4 GHz; 2.9 @ 5.8 GHz
Frequency	2 - 6 GHz

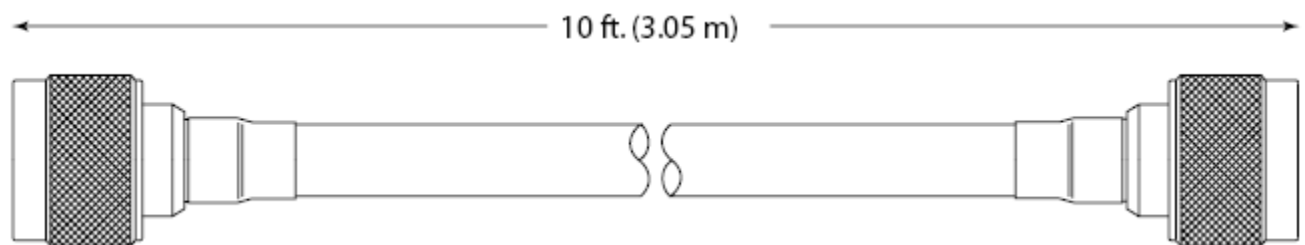

Figure 7: ML-1499-10JK-01R

ML-1499-25JK-01R 25 ft. Low-Loss Coaxial Cable Jumper: N Male to N Male with 2 Connector Seal Kits

Type	Ultralink TL 93605
RF Connectors	N (m) to N (m)
Cable Attenuation (dB)	2.5 @ 2.4 GHz; 4.0 @ 5.8 GHz
Frequency	2 - 6 GHz

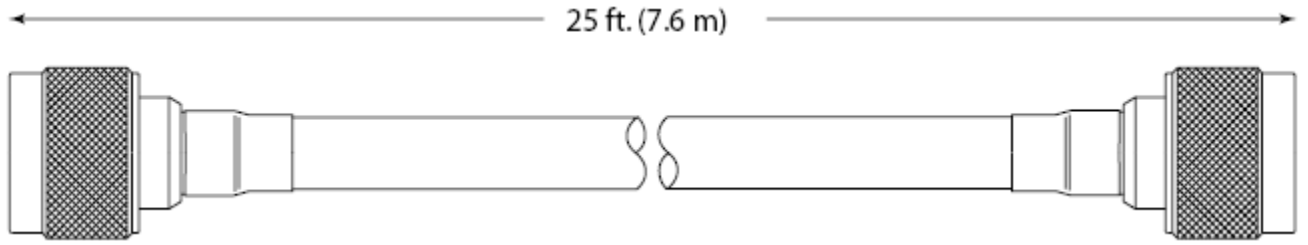

Figure 8: ML-1499-25JK-01R

7 Supported Antenna Adapters

25-85391-01R 3.5 in. Jumper Cable, RP-SMA (Male) to Type N (Male) Adapter
 25-85392-01R 3.5 in. Jumper Cable, RP-SMA (Male) to Type N (Female) Adapter
 25-72178-01 Jumper, RP-SMA(M) to RP-BNC(F)
 25-90262-01R RP-SMA (Female) to Type N (Female) Adapter
 25-90263-01R Type N (Male) to RP-SMA (Female) Bulkhead Adapter
 25-99175-01R Type N, Female to Female Adapter

Numerous adapters are supported to suit your unique access point deployment. Check the Support site periodically, as new adapters will be added to this document as they are released.

25-85391-01R 3.5 in. Jumper Cable, RP-SMA (Male) to Type N (Male) Adapter

Type	Clear Jacket, RG-316
Connector 1	RP-SMA, Male
Connector 2	Type N, Male
Insertion Loss	2.4 GHz: 0.2 dB MIN
Insertion Loss	5.2 GHz: 0.3 dB MIN

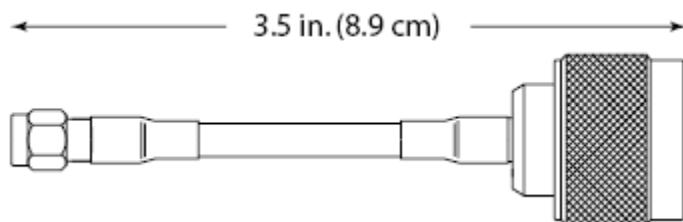
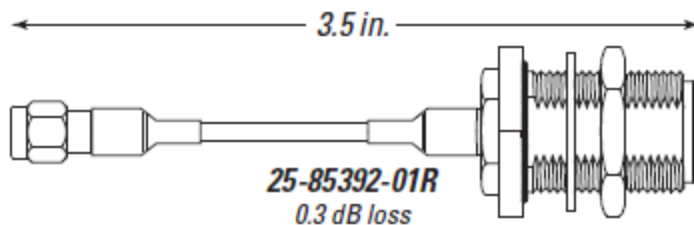

Figure 9: 25-85391-01R

25-85392-01R 3.5 in. Jumper Cable, RP-SMA (Male) to Type N (Female) Adapter

Type	Clear Jacket, RG-316
Connector 1	RP-SMA, Male
Connector 2	Type N, Female, Bulkhead
Insertion Loss	2.4 GHz: 0.2 dB MIN
Insertion Loss	5.2 GHz: 0.3 dB MIN



25-72178-01 Jumper, RP-SMA(M) to RP-BNC(F)

Type	RG-316
Connector 1	RP-SMA, Male
Connector 2	RP-BNC, Female
Insertion Loss	2.4 GHz: .2 dB
Insertion Loss	5.2 GHz: .3 dB

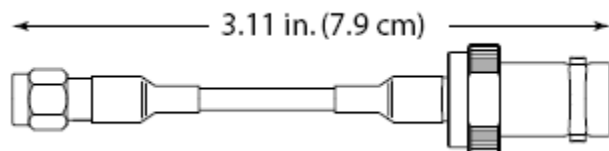

Figure 10: 25-72178-01

25-90262-01R RP-SMA (Female) to Type N (Female) Adapter

Type	RG-316
Connector 1	RP-SMA, Female, Bulkhead
Connector 2	Type N, Female, Bulkhead
Insertion Loss	2.4 GHz: .2 dB
Insertion Loss	5.2 GHz: .3 dB

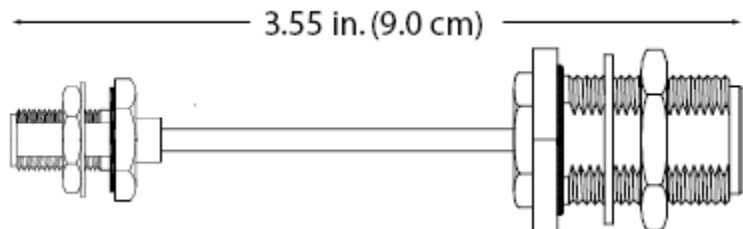

Figure 11: 25-90262-01R

25-90263-01R Type N (Male) to RP-SMA (Female) Bulkhead Adapter

Type	RG-316
Connector 1	Type N, Male
Connector 2	RP-SMA, Female, Bulkhead
Insertion Loss	2.4 GHz: 0.2 dB MIN
Insertion Loss	5.2 GHz: 0.3 dB MIN

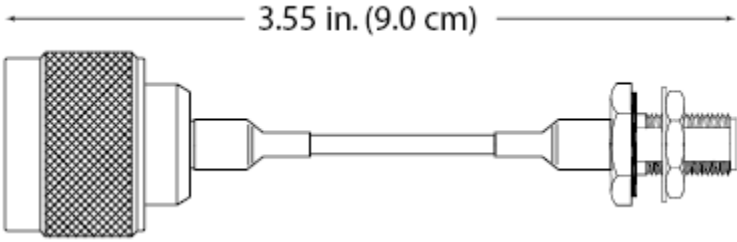
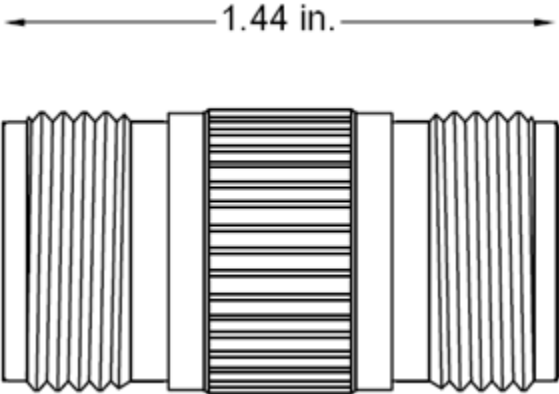

Figure 12: 25-90263-01R

25-99175-01R Type N, Female to Female Adapter

Connector 1	Type N, Female
Connector 2	Type N, Female
Cable Loss (dB)	0.3
Cable Length (inches)	1.44



8 Supported Lightning Arrestors

ML-1499-LAK1-01R 1 ft. N Male to RP BNC Male Lightning Arrestor with Connector Seal Kit

ML-2452-LAK1-01R Lightning Arrestor (N Female to N Female) with N Male to RP-SMA Male Adapter

ML-2452-LAK1-02R Type N, Male-Female

Several lightning arrestors are available to support your unique access point deployment safety requirements. Check the Support site periodically, as new lightning arrestors will be added to this document as they are released.



Warning

The grounding lug on a lightning arrestor must be grounded in compliance with local electrical codes.

ML-1499-LAK1-01R 1 ft. N Male to RP BNC Male Lightning Arrestor with Connector Seal Kit

Cable	Black, Ultralink, RG-58
RF Connectors	N (m) to RP. BNC (m)
Arrestor RF Connectors	N (f) to N (f)
Frequency	2400-2500 MHz
Insertion Loss - Lightning Arrestor	0.25 dB @ 2.4 GHz
Insertion Loss - Cable	0.6 dB @ 2.4 GHz

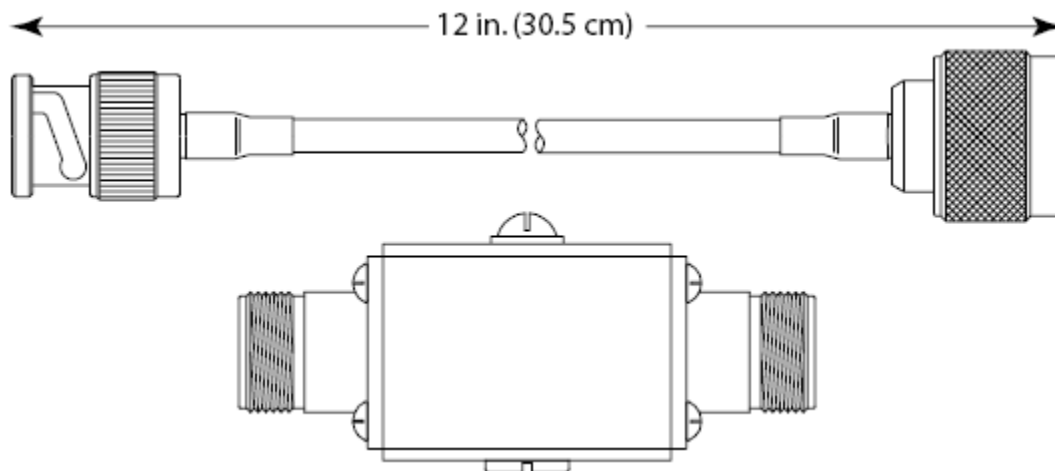

Note
Not for use above 2500 MHz.

Figure 13: ML-1499-LAK1-01R

ML-2452-LAK1-01R Lightning Arrestor (N Female to N Female) with N Male to RP-SMA Male Adapter

Cable	Black, Ultralink, RG-58
Connectors - Cable	N (m) to RP. SMA (m)
Frequency	100-6000 MHz
Insertion Loss - Cable	0.6 @ 2.4 GHz, 1.4 @ 5.5 GHz
Insulation Resistance	50 M-ohms
Connectors - Lightning Arrestor	Type N (f) to N (f)
Weight	4.5 oz
Operating Temperature	- 40° to 85°C
Insertion Loss - Lightning Arrestor	0.14 @ 2.4 GHz, 0.35 @ 5.5 GHz

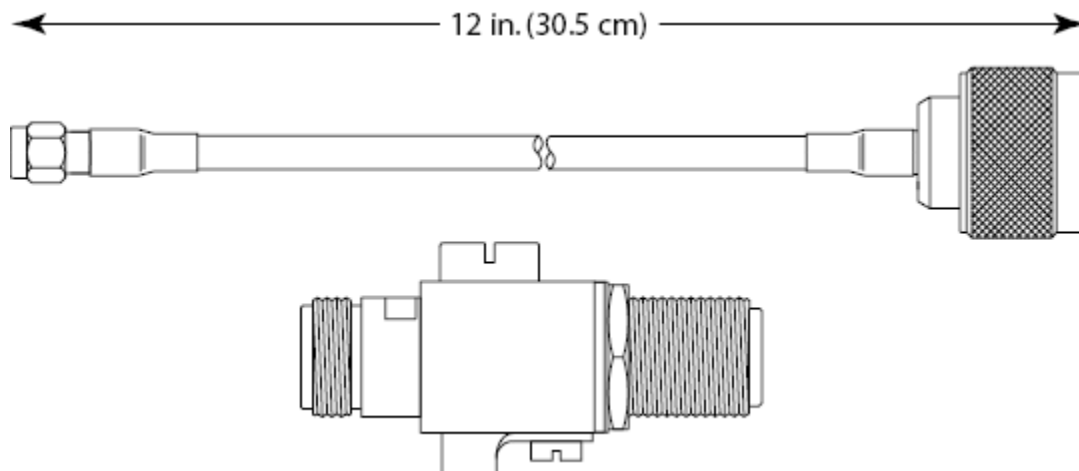

Figure 14: ML-2452-LAK1-01R

ML-2452-LAK1-02R Type N, Male-Female

RF Connector	Type N, Male-Female
Frequency	100-6000 MHz
Insertion Loss	0.4dB Max



9 Mounting Kits

ML-1499-SD3MK-01R Articulating I-Beam Mount Kit for ML-2499-SD3-01 Omni Antenna

Mounting kits are available to support your unique access point deployment. Check the Support site periodically, as new kits will be added to this document as they are released.

ML-1499-SD3MK-01R Articulating I-Beam Mount Kit for ML-2499-SD3-01 Omni Antenna

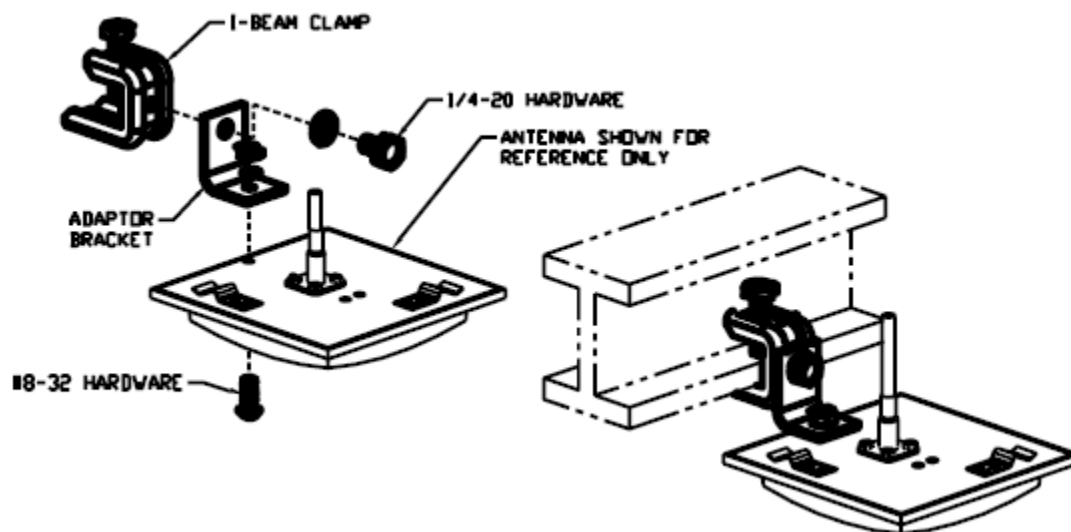

Functionality	Mounts Part No. ML-2499-SD3-01 to an I-beam.
---------------	--

10 AP7131 Regulatory Domains

AP7131 Supported Antennas by Band, Model, Rate and Transmit Power
 AP7131 Japan Regulatory Domain 2.4 GHz Band
 AP7131 Japan Regulatory Domain 5.2 GHz Band

AP7131 Supported Antennas by Band, Model, Rate and Transmit Power

Refer to the following AP7131 supported antennas for their US Regulatory Domain transmit power (in both the 2.4 and 5.2 GHz bands), rates, and supported channels.

AP7131 US Domain 2.4 GHz Mode Versus Data Rate

When setting 2.4 GHz data rates using the access point's GUI applet, use the following chart to cross reference data rates to the radio's selected operational mode.

	B, G and N	G and N	N Only	B and G	G Only	B Only
LEGACY DSSS RATES (1, 2, 5.5, 11 MBPS)	X			X		X
LEGACY OFDM RATES (6,9,12,18,24,36,48,54 MBPS)	X	X		X	X	
802.11n HT20 RATES (MCS 0 MCS 15)	X	X	X			
802.11n HT40 RATES (MCS 0 MCS15)	X	X	X			

AP7131 US Domain 2.4 GHz Yagi Antenna Models

The following is the Yagi antenna model for 2.4 GHz:

Part Number
ML-2499-BYGA2-01R

AP7131 US Domain 2.4 GHz Yagi Antenna Maximum Conducted Transmit Power Settings

The following is a transmit power table (US domain) per Yagi antenna in the 2.4 GHz band:

20 MHZ CHANNEL	40 MHZ CHANNEL	LEGACY DSSS RATES (1, 2, 5.5, 11 MBPS)	LEGACY OFDM RATES (6,9,12,18,24,36,48,54 MBPS)	802.11n HT20 RATES (MCS 0 MCS 15)	802.11n HT40 RATES (MCS 0 MCS15)
1		13	7	7	
2		13	7	7	
3	(1, 5)	13	7	7	2
4	(2, 6)	13	7	7	2
5	(3, 7)	13	7	7	2
6	(4, 8)	13	8	8	5
7	(5, 9)	12	7	6	2
8	(6, 10)	12	7	6	2
9	(7, 11)	12	7	6	2
10		12	7	6	
11		12	7	6	

With the most recent AP7131 series software release (4.0.0.0) the Web browser of the command line interface do not allow setting the transmit power to any value less than 4dBm.



Note

When a Yagi antenna is used, a 2dB external RF attenuator must be added. Lower power settings will be provided in subsequent software releases.

AP7131 US Domain 2.4 GHz Panel Antenna Models

The following is the panel antenna model for 2.4 GHz:

Part Number
ML-2452-PTA3M3-036

AP7131 US Domain 2.4 GHz Panel Antenna Maximum Conducted Transmit Power Settings

The following is a transmit power table (US domain) per panel antenna in the 2.4 GHz band:

20 MHZ CHANNEL	40 MHZ CHANNEL	LEGACY DSSS RATES (1, 2, 5.5, 11 MBPS)	LEGACY OFDM RATES (6,9,12,18,24,36,48,54 MBPS)	802.11n HT20 RATES (MCS 0 MCS 15)	802.11n HT40 RATES (MCS 0 MCS15)
1		16	11	10	
2		16	11	10	
3	(1, 5)	16	11	10	7
4	(2, 6)	16	11	10	7
5	(3, 7)	16	11	10	7

20 MHZ CHANNEL	40 MHZ CHANNEL	LEGACY DSSS RATES (1, 2, 5.5, 11 MBPS)	LEGACY OFDM RATES (6,9,12,18,24,36,48,54 MBPS)	802.11n HT20 RATES (MCS 0 MCS 15)	802.11n HT40 RATES (MCS 0 MCS15)
6	(4, 8)	16	11	11	8
7	(5, 9)	16	11	9	5
8	(6, 10)	16	11	9	5
9	(7, 11)	16	11	9	5
10		16	11	9	
11		16	11	9	

AP7131 US Domain 2.4 GHz Embedded Antenna Models

The following is the embedded antenna model for 2.4 GHz:

Part Number
ML-2452-PTA2M3X3-1

AP 7131 US Domain 2.4 GHz Embedded Antenna Maximum Conducted Transmit Power Settings

The following is a transmit power table (US domain) per embedded antenna in the 2.4 GHz band:

20 MHZ CHANNEL	40 MHZ CHANNEL	LEGACY DSSS RATES (1, 2, 5.5, 11 MBPS)	LEGACY OFDM RATES (6,9,12,18,24,36,48,54 MBPS)	802.11n HT20 RATES (MCS 0 MCS 15)	802.11n HT40 RATES (MCS 0 MCS15)
1		20	16	16	
2		20	16	16	
3	(1, 5)	20	16	16	11
4	(2, 6)	20	16	16	11
5	(3, 7)	20	16	16	11
6	(4, 8)	18	14	14	12
7	(5, 9)	16	15	15	12
8	(6, 10)	16	15	15	12
9	(7, 11)	16	15	15	12
10		16	15	15	
11		16	15	15	

AP7131 US Domain 2.4 GHz Dipole Antenna Models

The following are the dipole antenna models for 2.4 GHz:

Part Number	2.4 GHz Antenna Net Gain
ML-2452-APA2-01	3
ML-2499-HPA3-01R	4.7
ML-2452-APA6J-01 (microcell)	- 6

AP7131 US Domain 2.4 GHz Dipole Antenna Maximum Conducted Transmit Power Settings

The following is a transmit power table (US domain) per dipole antenna in the 2.4 GHz band:

20 MHZ CHANNEL	40 MHZ CHANNEL	LEGACY DSSS RATES (1, 2, 5.5, 11 MBPS)	LEGACY OFDM RATES (6,9,12,18,24,36,48,54 MBPS)	802.11n HT20 RATES (MCS 0 MCS 15)	802.11n HT40 RATES (MCS0 MCS15)
1		18.5	15.0	15.0	
2		18.5	15.0	15.0	
3	(1, 5)	18.5	16.0	16.5	10.0
4	(2, 6)	18.5	16.0	16.5	11.0
5	(3, 7)	18.5	16.0	16.0	12.0
6	(4, 8)	23.0	16.0	16.5	13.0
7	(5, 9)	19.0	16.0	16.5	12.0
8	(6, 10)	19.0	16.0	16.5	11.0
9	(7, 11)	19.0	15.0	16.5	9.0
10		19.0	14.0	16.0	
11		19.0	13.5	13.0	

Note



The access point GUI only allows whole numbers be entered for transmit power. The decimal values are displayed within these tables to help installers accommodate for cable and accessory losses.

AP7131 US Domain 2.4 GHz Patch Antenna Models

The following is the patch antenna model for 2.4 GHz:

Part Number	2.4 GHz Antenna Net Gain
ML-2452-PTA3M3-036	3

AP7131 US Domain 2.4 GHz Patch Antenna Maximum Conducted Transmit Power Settings

The following is a transmit power table (US domain) per patch antenna in the 2.4 GHz band:

20 MHZ CHANNEL	40 MHZ CHANNEL	LEGACY DSSS RATES (1, 2, 5.5, 11 MBPS)	LEGACY OFDM RATES (6,9,12,18,24,36,48,54 MBPS)	802.11n HT20 RATES (MCS 0 MCS 15)	802.11n HT40 RATES (MCS0 MCS15)
1		16	15	12	
2		16	15	12	
3	(1, 5)	16	15	12	9
4	(2, 6)	16	15	12	9
5	(3, 7)	16	15	12	9
6	(4, 8)	20	15	15	12
7	(5, 9)	18	13	12	10
8	(6, 10)	18	13	12	10
9	(7, 11)	18	13	12	10
10		18	13	12	
11		18	13	12	

AP7131 US Domain 5.2 GHz Mode Versus Data Rate

When setting 5.2 GHz data rates using the access point's GUI applet, use the following chart to cross reference data rates to the radio's selected operational mode.

	A and N	N Only	A Only
LEGACY OFDM RATES (6,9,12,18,24,36,48,54 MBPS)	X		X
802.11n HT20 RATES (MCS 0 MCS 15)	X	X	
802.11n HT40 RATES (MCS 0 MCS 15)	X	X	

AP7131 US Domain 5.2 GHz Yagi Antenna Models

The following is the Yagi antenna model for 5.2 GHz:

Part Number
ML-5299-BYGA15-012

AP 7131 US Domain 5 GHz Yagi Antenna Maximum Conducted Transmit Power Settings

The following is a transmit power table (US domain) per Yagi antenna in the 5 GHz band:

20 MHZ CHANNEL	40 MHZ CHANNEL	LEGACY OFDM RATES (6,9,12,18,24,36,48,54 MBPS)	802.11n HT20 RATES (MCS 0 MCS 15)	802.11n HT40 RATES (MCS 0 MCS 15)
36		2	2.5	
38	(36, 40)			4
40		2	2.5	
42		2.5	2.5	
44		2.5	2.5	
46	(44, 48)			4
48		2.5	4	
52		9	9	
54	(52, 56)			11
56		9	9	
60		8.5	9	
62	(60, 64)			10
64		8.5	9	
100		8	8.5	
102	(100, 104)			5
104		8	8.5	
108		8	8.5	
112		8	8.5	
110	(108, 112)			11
116		8	8.5	
118	(116, 120)			10
120		8	8.5	
124		7.5	7.5	
126	(124, 128)			10
128		7.5	7.5	
132		7.5	7.5	
134	(132, 136)			10
136		7.5	7.5	
140		7.5	7.5	
149		7.0	7.5	
151	(149, 153)			4.5
153		7.0	7.5	
157		7.5	8.0	
159	(157, 161)			5.0

20 MHZ CHANNEL	40 MHZ CHANNEL	LEGACY OFDM RATES (6,9,12,18,24,36,48,54 MBPS)	802.11n HT20 RATES (MCS 0 MCS 15)	802.11n HT40 RATES (MCS 0 MCS 15)
161		8.0	9.0	
165		8.0	9.0	

AP7131 US Domain 5.2 GHz Panel Antenna Models

The following are the panel antenna models for 5.2 GHz:

Part Number
ML-5299-WPNA1-01R
ML-2452-PNL9M3-036

AP7131 US Domain 5 GHz Panel Antenna Maximum Conducted Transmit Power Settings

The following is a transmit power table (US domain) per panel antenna in the 5 GHz band:

20 MHZ CHANNEL	40 MHZ CHANNEL	LEGACY OFDM RATES (6,9,12,18,24,36,48,54 MBPS)	802.11n HT20 RATES (MCS 0 MCS 15)	802.11n HT40 RATES (MCS 0 MCS 15)
36		4	4	
38	(36, 40)			6
40		4	4	
42		4	4	
44		4	4	
46	(44, 48)			6
48		4	4	
52		10	10	
54	(52, 56)			13
56		10	10	
60		10	10	
62	(60, 64)			11
64		10	10	
100		10	10	
102	(100, 104)			5
104		10	10	
108		10	10	
112		10	10	
110	(108, 112)			13

20 MHZ CHANNEL	40 MHZ CHANNEL	LEGACY OFDM RATES (6,9,12,18,24,36,48,54 MBPS)	802.11n HT20 RATES (MCS 0 MCS 15)	802.11n HT40 RATES (MCS 0 MCS 15)
116		10	10	
118	(116, 120)			13
120		10	10	
124		10	10	
126	(124, 128)			12
128		10	10	
132		10	10	
134	(132, 136)			12
136		10	10	
140		8	8	
149		8.0	9.0	
151	(149, 153)			6.0
153		8.0	9.0	
157		9.0	10.0	
159	(157, 161)			7.0
161		10	10	
165		10	10	

AP7131 US Domain 5.2 GHz Embedded Antenna Models

The following is the embedded antenna model for 5.2 GHz:

Part Number
ML-2452-PTA2M3X3-1

AP7131 US Domain 5.2 GHz Embedded Antenna Maximum Conducted Transmit Power Settings

The following is a transmit power table (US domain) per embedded antenna in the 5 GHz band:

20 MHZ CHANNEL	40 MHZ CHANNEL	LEGACY OFDM RATES (6,9,12,18,24,36,48,54 MBPS)	802.11n HT20 RATES (MCS 0 MCS 15)	802.11n HT40 RATES (MCS 0 MCS 15)
36		11	11	
38	(36, 40)			12
40		11	11	
42		11	11	
44		11	11	

20 MHZ CHANNEL	40 MHZ CHANNEL	LEGACY OFDM RATES (6,9,12,18,24,36,48,54 MBPS)	802.11n HT20 RATES (MCS 0 MCS 15)	802.11n HT40 RATES (MCS 0 MCS 15)
46	(44, 48)			13
48		11	11	
52		18	18	
54	(52, 56)			20
56		18	18	
60		18	18	
62	(60, 64)			14
64		18	18	
100		15	16	
102	(100, 104)			8
104		14	16	
108		14	16	
112		14	16	
110	(108, 112)			19
116		14	16	
118	(116, 120)			19
120		18	18	
124		18	13	
126	(124, 128)			19
128		14	13	
132		14	13	
134	(132, 136)			14
136		13	13	
140		13	13	
149		18.0	18.0	
151	(149, 153)			15.0
153		18.0	18.0	
157		18.0	18.0	
159	(157, 161)			16.0
161		19.0	19.0	
165		19.0	19.0	

AP7131 US Domain 5.2 GHz Dipole Antenna Models

The following are the dipole antenna models for 5.2 GHz:

Part Number
ML-5299HPA1-01R
ML-2452-APA6J-01
ML-2452-APA2-01

AP7131 US Domain 5 GHz Dipole Antenna Maximum Conducted Transmit Power Settings

The following is a transmit power table (US domain) per dipole antenna in the 5 GHz band:

20 MHZ CHANNEL	40 MHZ CHANNEL	LEGACY OFDM RATES (6,9,12,18,24,36,48,54 MBPS)	802.11n HT20 RATES (MCS 0 MCS 15)	802.11n HT40 RATES (MCS 0 MCS 15)
36		11	11	
38	(36, 40)			12
40		11	11	
42		11	11	
44		11	11	
46	(44, 48)			13
48		11	11	
52		18	18	
54	(52, 56)			20
56		18	18	
60		18	18	
62	(60, 64)			14
64		18	18	
100		15	14	
102	(100, 104)			7
104		15	14	
108		15	14	
112		15	14	
110	(108, 112)			19
116		15	14	
118	(116, 120)			19
120		18	18	
124		15	18	
126	(124, 128)			19
128		15	18	

20 MHZ CHANNEL	40 MHZ CHANNEL	LEGACY OFDM RATES (6,9,12,18,24,36,48,54 MBPS)	802.11n HT20 RATES (MCS 0 MCS 15)	802.11n HT40 RATES (MCS 0 MCS 15)
132		15	18	
134	(132, 136)			14
136		13	16	
140		13	16	
149		18.0	18.0	
151	(149, 153)			15.0
153		18.0	19.0	
157		18.0	19.0	
159	(157, 161)			16.0
161		19.0	19.0	
165		19.0	19.0	

AP7131 US Domain 5.2 GHz Patch Antenna Models

The following is the patch antenna model for 5.2 GHz:

Part Number
ML-2452-PTA3M3-036

AP7131 US Domain 5 GHz Patch Antenna Maximum Conducted Transmit Power Settings

The following is a transmit power table (US domain) per patch antenna in the 5 GHz band:

20 MHZ CHANNEL	40 MHZ CHANNEL	LEGACY OFDM RATES (6,9,12,18,24,36,48,54 MBPS)	802.11n HT20 RATES (MCS 0 MCS 15)	802.11n HT40 RATES (MCS 0 MCS 15)
36		11	11	
38	(36, 40)			12
40		11	11	
42		11	11	
44		11	11	
46	(44, 48)			13
48		11	11	
52		18	18	
54	(52, 56)			20
56		18	18	
60		18	18	

20 MHZ CHANNEL	40 MHZ CHANNEL	LEGACY OFDM RATES (6,9,12,18,24,36,48,54 MBPS)	802.11n HT20 RATES (MCS 0 MCS 15)	802.11n HT40 RATES (MCS 0 MCS 15)
62	(60, 64)			14
64		18	18	
100		15	16	
102	(100, 104)			8
104		18	16	
108		18	16	
112		18	18	
110	(108, 112)			13
116		18	18	
118	(116, 120)			19
120		18	18	
124		18	18	
126	(124, 128)			19
128		18	18	
132		18	18	
134	(132, 136)			14
136		13	13	
140		13	13	
149		18.0	18.0	
151	(149, 153)			15.0
153		18.0	19.0	
157		18.0	19.0	
159	(157, 161)			16.0
161		19.0	19.0	
165		19.0	19.0	

AP7131 Japan Regulatory Domain 2.4 GHz Band

AP7131 Japan Domain 2.4 GHz Panel Antenna Model

The following is the panel antenna model for 2.4 GHz:

Part Number
ML-2499-11PNA2-01R

AP7131 Japan Domain 2.4 GHz Panel Antenna Maximum Conducted Transmit Power Settings

The following is a transmit power table (Japan domain) per panel antenna in the 2.4 GHz band:

20 MHZ CHANNEL	40 MHZ CHANNEL	LEGACY DSSS RATES (1, 2, 5.5, 11 MBPS)	LEGACY OFDM RATES (6,9,12,18,24,36,48,54 MBPS)	802.11n HT20 RATES (MCS 0 MCS 15)	802.11n HT40 RATES (MCS 0 MCS15)
1		19.0	19.0	19.0	
2		19.0	19.0	19.0	
3	(1, 5)	19.0	19.0	19.0	16.0
4	(2, 6)	19.0	19.0	19.0	16.0
5	(3, 7)	19.0	19.0	19.0	16.0
6	(4, 8)	19.0	19.0	19.0	16.0
7	(5, 9)	19.0	19.0	19.0	16.0
8	(6, 10)	19.0	19.0	19.0	16.0
9	(7, 11)	19.0	19.0	19.0	16.0
10		19.0	19.0	19.0	
11		19.0	19.0	19.0	
12		19.0	19.0	19.0	
13		19.0	19.0	19.0	
14		19.0			

AP7131 Japan Domain 2.4 GHz Embedded Antenna Model

The following is the embedded antenna model for 2.4 GHz:

Part Number
ML-2452-PTA2M3X3-1

AP7131 Japan Domain 2.4 GHz Panel Antenna Maximum Conducted Transmit Power Settings

The following is a transmit power table (Japan domain) per embedded antenna in the 2.4 GHz band:

20 MHZ CHANNEL	40 MHZ CHANNEL	LEGACY DSSS RATES (1, 2, 5.5, 11 MBPS)	LEGACY OFDM RATES (6,9,12,18,24,36,48,54 MBPS)	802.11n HT20 RATES (MCS 0 MCS 15)	802.11n HT40 RATES (MCS 0 MCS15)
1		11.0	11.0	11.0	
2		11.0	11.0	11.0	
3	(1, 5)	11.0	11.0	11.0	8.0

20 MHZ CHANNEL	40 MHZ CHANNEL	LEGACY DSSS RATES (1, 2, 5.5, 11 MBPS)	LEGACY OFDM RATES (6,9,12,18,24,36,48,54 MBPS)	802.11n HT20 RATES (MCS 0 MCS 15)	802.11n HT40 RATES (MCS 0 MCS15)
4	(2, 6)	11.0	11.0	11.0	8.0
5	(3, 7)	11.0	11.0	11.0	8.0
6	(4, 8)	11.0	11.0	11.0	8.0
7	(5, 9)	11.0	11.0	11.0	8.0
8	(6, 10)	11.0	11.0	11.0	8.0
9	(7, 11)	11.0	11.0	11.0	8.0
10		11.0	11.0	11.0	
11		11.0	11.0	11.0	
12		11.0	11.0	11.0	
13		11.0	11.0	11.0	
14		11.0			

AP7131 Japan Domain 2.4 GHz Dipole Antenna Model

The following is the patch antenna model for 2.4 GHz:

Part Number
ML-2452-APA2-01 ML-2499-HPA3-01R ML-2452-APA6J-01 (microcell)

AP7131 Japan Domain 2.4 GHz Dipole Antenna Maximum Conducted Transmit Power Settings

The following is a transmit power table (Japan domain) per dipole antenna in the 2.4 GHz band:

20 MHZ CHANNEL	40 MHZ CHANNEL	LEGACY DSSS RATES (1, 2, 5.5, 11 MBPS)	LEGACY OFDM RATES (6,9,12,18,24,36,48,54 MBPS)	802.11n HT20 RATES (MCS 0 MCS 15)	802.11n HT40 RATES (MCS 0 MCS15)
1		14.0	14.0	14.0	
2		14.0	14.0	14.0	
3	(1, 5)	14.0	14.0	14.0	11
4	(2, 6)	14.0	14.0	14.0	11
5	(3, 7)	14.0	14.0	14.0	11
6	(4, 8)	14.0	14.0	14.0	11
7	(5, 9)	14.0	14.0	14.0	11
8	(6, 10)	14.0	14.0	14.0	11
9	(7, 11)	14.0	14.0	14.0	11

20 MHZ CHANNEL	40 MHZ CHANNEL	LEGACY DSSS RATES (1, 2, 5.5, 11 MBPS)	LEGACY OFDM RATES (6,9,12,18,24,36,48,54 MBPS)	802.11n HT20 RATES (MCS 0 MCS 15)	802.11n HT40 RATES (MCS 0 MCS15)
10		14.0	14.0	14.0	
11		14.0	14.0	14.0	
12		14.0	14.0	14.0	
13		14.0	14.0	14.0	
14		14.0			

AP7131 Japan Domain 2.4 GHz Patch Antenna Model

The following is the patch antenna model for 2.4 GHz:

Part Number	2.4 GHz Antenna Net Gain
ML-2452-PTA3M3-036	3

AP7131 Japan Domain 2.4 GHz Patch Antenna Maximum Conducted Transmit Power Settings

The following is a transmit power table (Japan domain) per patch antenna in the 2.4 GHz band:

20 MHZ CHANNEL	40 MHZ CHANNEL	LEGACY DSSS RATES (1, 2, 5.5, 11 MBPS)	LEGACY OFDM RATES (6,9,12,18,24,36,48,54 MBPS)	802.11n HT20 RATES (MCS 0 MCS 15)	802.11n HT40 RATES (MCS0 MCS15)
1		16.0	16.0	16.0	
2		16.0	16.0	16.0	
3	(1, 5)	16.0	16.0	16.0	10.0
4	(2, 6)	16.0	16.0	16.0	10.0
5	(3, 7)	16.0	16.0	16.0	10.0
6	(4, 8)	16.0	16.0	16.0	10.0
7	(5, 9)	16.0	16.0	16.0	10.0
8	(6, 10)	16.0	16.0	16.0	10.0
9	(7, 11)	16.0	16.0	16.0	10.0
10		16.0	16.0	16.0	
11		16.0	16.0	16.0	
12		16.0	16.0	16.0	
13		16.0	16.0	16.0	
14		16.0			

AP7131 Japan Regulatory Domain 5.2 GHz Band

AP7131 Japan Domain 5.2 GHz Panel Antenna Models

The following are the panel antenna models for 5.2 GHz:

Part Number
ML-5299-WPNA1-01R ML-2452-PNL9M3-036

AP7131 Japan Domain 5.2 GHz Panel Antenna Maximum Conducted Transmit Power Settings

The following is a transmit power table (Japan domain) per panel antenna in the 5 GHz band:

20 MHZ CHANNEL	40 MHZ CHANNEL	LEGACY OFDM RATES (6,9,12,18,24,36,48,54 MBPS)	802.11n HT20 RATES (MCS 0 MCS 15)	802.11n HT40 RATES (MCS 0 MCS 15)
36		12.0	12.0	
38	(36, 40)			18.0
40		12.0	12.0	
42		12.0	12.0	
44		12.0	12.0	
46	(44, 48)			18.0
48		12.0	12.0	
52		12.0	12.0	
54	(52, 56)			18.0
56		12.0	12.0	
60		12.0	12.0	
62	(60, 64)			18.0
64		12.0	12.0	
100		19.0	19.0	
102	(100, 104)			18.0
104		19.0	19.0	
108		19.0	19.0	
112		19.0	19.0	
110	(108, 112)			18.0
116		19.0	19.0	
118	(116, 120)			18.0
120		19.0	19.0	
124		19.0	19.0	

20 MHZ CHANNEL	40 MHZ CHANNEL	LEGACY OFDM RATES (6,9,12,18,24,36,48,54 MBPS)	802.11n HT20 RATES (MCS 0 MCS 15)	802.11n HT40 RATES (MCS 0 MCS 15)
126	(124, 128)			18.0
128		19.0	19.0	
132		19.0	19.0	
134	(132, 136)			18.0
136		19.0	19.0	
140		19.0	19.0	
149				
151	(149, 153)			
153				
157				
159	(157, 161)			
161				
165				

AP7131 Japan Domain 5.2 GHz Embedded Antenna Model

The following is the embedded antenna model for 5.2 GHz:

Part Number
ML-5299-WPNA1-01R

AP7131 Japan Domain 5.2 GHz Embedded Antenna Maximum Conducted Transmit Power Settings

The following is a transmit power table (Japan domain) per embedded antenna in the 5 GHz band:

20 MHZ CHANNEL	40 MHZ CHANNEL	LEGACY OFDM RATES (6,9,12,18,24,36,48,54 MBPS)	802.11n HT20 RATES (MCS 0 MCS 15)	802.11n HT40 RATES (MCS 0 MCS 15)
36		10.0	10.0	
38	(36, 40)			7.0
40		10.0	10.0	
42		10.0	10.0	
44		10.0	10.0	
46	(44, 48)			7.0
48		10.0	10.0	
52		10.0	10.0	
54	(52, 56)			7.0

20 MHZ CHANNEL	40 MHZ CHANNEL	LEGACY OFDM RATES (6,9,12,18,24,36,48,54 MBPS)	802.11n HT20 RATES (MCS 0 MCS 15)	802.11n HT40 RATES (MCS 0 MCS 15)
56		10.0	10.0	
60		10.0	10.0	
62	(60, 64)			7.0
64		10.0	10.0	
100		17.0	17.0	
102	(100, 104)			7.0
104		17.0	17.0	
108		17.0	17.0	
112		17.0	17.0	
110	(108, 112)			7.0
116		17.0	17.0	
118	(116, 120)			7.0
120		17.0	17.0	
124		17.0	17.0	
126	(124, 128)			7.0
128		17.0	17.0	
132		17.0	17.0	
134	(132, 136)			7.0
136		17.0	17.0	
140		17.0	17.0	
149				
151	(149, 153)			
153				
157				
159	(157, 161)			
161				
165				

AP7131 Japan Domain 5.2 GHz Dipole Antenna Models

The following are the dipole antenna models for 5.2 GHz:

Part Number
ML-5299-HPA1-01R ML-2452-APA6J-01 ML-2452-APA2-01

AP7131 Japan Domain 5.2 GHz Dipole Antenna Maximum Conducted Transmit Power Settings

The following is a transmit power table (Japan domain) per dipole antenna in the 5 GHz band:

20 MHZ CHANNEL	40 MHZ CHANNEL	LEGACY OFDM RATES (6,9,12,18,24,36,48,54 MBPS)	802.11n HT20 RATES (MCS 0 MCS 15)	802.11n HT40 RATES (MCS 0 MCS 15)
36		12.0	12.0	
38	(36, 40)			9.0
40		12.0	12.0	
42		12.0	12.0	
44		12.0	12.0	
46	(44, 48)			9.0
48		12.0	12.0	
52		12.0	12.0	
54	(52, 56)			9.0
56		12.0	12.0	
60		12.0	12.0	
62	(60, 64)			9.0
64		12.0	12.0	
100		19.0	19.0	
102	(100, 104)			9.0
104		19.0	19.0	
108		19.0	19.0	
112		19.0	19.0	
110	(108, 112)			9.0
116		19.0	19.0	
118	(116, 120)			9.0
120		19.0	19.0	
124		19.0	19.0	
126	(124, 128)			9.0
128		19.0	19.0	
132		19.0	19.0	
134	(132, 136)			9.0
136		19.0	19.0	
140		19.0	19.0	
149				
151	(149, 153)			

20 MHZ CHANNEL	40 MHZ CHANNEL	LEGACY OFDM RATES (6,9,12,18,24,36,48,54 MBPS)	802.11n HT20 RATES (MCS 0 MCS 15)	802.11n HT40 RATES (MCS 0 MCS 15)
153				
157				
159	(157, 161)			
161				
165				

AP7131 Japan Domain 5.2 GHz Patch Antenna Model

The following is the patch antenna model for 5.2 GHz:

Part Number
ML-2452-PTA3M3-036

AP7131 Japan Domain 5 GHz Patch Antenna Maximum Conducted Transmit Power Settings

The following is a transmit power table (Japan domain) per patch antenna in the 5 GHz band:

20 MHZ CHANNEL	40 MHZ CHANNEL	LEGACY OFDM RATES (6,9,12,18,24,36,48,54 MBPS)	802.11n HT20 RATES (MCS 0 MCS 15)	802.11n HT40 RATES (MCS 0 MCS 15)
36		21.0	21.0	
38	(36, 40)			10.0
40		21.0	21.0	
42		21.0	21.0	
44		21.0	21.0	
46	(44, 48)			10.0
48		21.0	21.0	
52		21.0	21.0	
54	(52, 56)			10.0
56		21.0	21.0	
60		21.0	21.0	
62	(60, 64)			10.0
64		21.0	21.0	
100		20.0	20.0	
102	(100, 104)			17.0
104		20.0	20.0	
108		20.0	20.0	

20 MHZ CHANNEL	40 MHZ CHANNEL	LEGACY OFDM RATES (6,9,12,18,24,36,48,54 MBPS)	802.11n HT20 RATES (MCS 0 MCS 15)	802.11n HT40 RATES (MCS 0 MCS 15)
112		20.0	20.0	
110	(108, 112)			17.0
116		20.0	20.0	
118	(116, 120)			17.0
120		20.0	20.0	
124		20.0	20.0	
126	(124, 128)			17.0
128		20.0	20.0	
132		20.0	20.0	
134	(132, 136)			17.0
136		20.0	20.0	
140		20.0	20.0	
149				
151	(149, 153)			
153				
157				
159	(157, 161)			
161				
165				

11 AP650 Regulatory Domains

AP650 US Regulatory Domain 2.4 GHz Band
 AP650 US Regulatory Domain 5 GHz Band
 AP650 Japan Regulatory Domain 2.4 GHz Band
 AP650 Japan Regulatory Domain 5 GHz Band
 AP650 EU Regulatory Domain 2.4 GHz Band
 AP650 EU Regulatory Domain 5 GHz Band

AP650 US Regulatory Domain 2.4 GHz Band

AP650 US Domain 2.4 GHz Dipole Antenna Maximum Conducted Transmit Power Settings

The following is a transmit power table (US domain) per dipole antenna in the 2.4 GHz band:

20 MHZ CHANNEL	40 MHZ CHANNEL	LEGACY DSSS RATES (1, 2, 5.5, 11 MBPS)	LEGACY OFDM RATES (6,9,12,18,24,36,48,54 MBPS)	802.11n HT20 RATES (MCS 0 MCS 15)	802.11n HT40 RATES (MCS 0 MCS15)
1		19.5	16.5	16.0	
2		19.0	16.5	16.0	
3	(1, 5)	19.0	20.0	20.0	13.5
4	(2, 6)	19.0	20.0	20.0	13.5
5	(3, 7)	19.0	20.0	20.0	15.5
6	(4, 8)	19.0	20.0	20.0	15.5
7	(5, 9)	19.0	20.0	20.0	15.5
8	(6, 10)	19.0	20.0	20.0	11.5
9	(7, 11)	19.0	20.0	20.0	11.5
10	(8, 12)	19.0	14.0	14.0	
11	(9, 13)	19.0	14.0	14.0	

Net peak gain = 3dBi -> 10dBi

AP650 US Domain 2.4 GHz Internal Dual Band Antenna Maximum Conducted Transmit Power Settings

The following is a transmit power table (US domain) per internal dual band antenna in the 2.4 GHz band:

20 MHZ CHANNEL	40 MHZ CHANNEL	LEGACY DSSS RATES (1, 2, 5.5, 11 MBPS)	LEGACY OFDM RATES (6,9,12,18,24,36,48,54 MBPS)	802.11n HT20 RATES (MCS 0 MCS 15)	802.11n HT40 RATES (MCS 0 MCS15)
1		19.0	16.0	15.0	
2		19.0	16.0	15.0	
3	(1, 5)	21.0	16.0	15.0	12.5
4	(2, 6)	21.0	21.0	20.0	12.5
5	(3, 7)	21.0	21.0	20.0	12.5
6	(4, 8)	21.0	21.0	20.0	15.5
7	(5, 9)	21.0	21.0	20.0	11.5
8	(6, 10)	21.0	21.0	20.0	11.5
9	(7, 11)	21.0	16.0	15.0	11.5
10	(8, 12)	18.5	16.0	15.0	
11	(9, 13)	18.5	16.0	15.0	

Net peak gain = 2dBi

AP650 US Domain 2.4 GHz Indoor Patch Antenna Maximum Conducted Transmit Power Settings

The following is a transmit power table (US domain) per Indoor Patch antenna in the 2.4 GHz band:

20 MHZ CHANNEL	40 MHZ CHANNEL	LEGACY DSSS RATES (1, 2, 5.5, 11 MBPS)	LEGACY OFDM RATES (6,9,12,18,24,36,48,54 MBPS)	802.11n HT20 RATES (MCS 0 MCS 15)	802.11n HT40 RATES (MCS 0 MCS15)
1		19.5	16.0	16.5	
2		19.5	16.0	16.5	
3	(1, 5)	17.5	18.0	16.5	11.5
4	(2, 6)	21.0	18.0	16.5	11.5
5	(3, 7)	21.0	18.0	16.5	16.5
6	(4, 8)	21.0	18.0	16.5	13.5
7	(5, 9)	21.0	18.0	16.5	16.5
8	(6, 10)	21.0	18.0	16.5	12.0
9	(7, 11)	21.0	18.0	16.5	12.0
10	(8, 12)	19.0	15.5	15.0	
11	(9, 13)	19.0	15.5	15.0	

Net peak gain = 7.5dBi

AP650 US Domain 2.4 GHz Outdoor Omni Antenna Maximum Conducted Transmit Power Settings

The following is a transmit power table (US domain) per outdoor omni antenna in the 2.4 GHz band:

20 MHZ CHANNEL	40 MHZ CHANNEL	LEGACY DSSS RATES (1, 2, 5.5, 11 MBPS)	LEGACY OFDM RATES (6,9,12,18,24,36,48,54 MBPS)	802.11n HT20 RATES (MCS 0 MCS 15)	802.11n HT40 RATES (MCS0 MCS15)
1		19.0	13.5	14.0	
2		19.0	13.5	14.0	
3	(1, 5)	19.0	13.5	14.0	10.5
4	(2, 6)	21.0	19.0	19.0	10.5
5	(3, 7)	21.0	19.0	19.0	10.5
6	(4, 8)	21.0	19.0	19.0	14.0
7	(5, 9)	21.0	19.0	19.0	9.5
8	(6, 10)	21.0	19.0	19.0	9.5
9	(7, 11)	19.5	14.0	13.0	9.5
10	(8, 12)	19.5	14.0	13.0	
11	(9, 13)	19.5	14.0	13.0	

Net peak gain = 3.3dBi

AP650 US Domain 2.4 GHz Panel Antenna Maximum Conducted Transmit Power Settings

The following is a transmit power table (US domain) per panel antenna in the 2.4 GHz band:

20 MHZ CHANNEL	40 MHZ CHANNEL	LEGACY DSSS RATES (1, 2, 5.5, 11 MBPS)	LEGACY OFDM RATES (6,9,12,18,24,36,48,54 MBPS)	802.11n HT20 RATES (MCS 0 MCS 15)	802.11n HT40 RATES (MCS0 MCS15)
1		14.5	13.5	12.0	
2		14.5	13.5	12.0	
3	(1, 5)	14.5	15.0	15.0	8.5
4	(2, 6)	14.5	15.0	15.0	8.5
5	(3, 7)	14.5	15.0	15.0	12.0
6	(4, 8)	14.5	15.0	15.0	12.0
7	(5, 9)	14.5	15.0	15.0	12.0
8	(6, 10)	14.5	15.0	15.0	8.5
9	(7, 11)	14.5	15.0	15.0	8.5
10	(8, 12)	14.0	12.0	11.0	
11	(9, 13)	14.0	12.0	11.0	

Net peak gain = 15.5dBi

AP650 US Regulatory Domain 5 GHz Band

AP650 US Domain 5 GHz Dual Band Dipole Antenna Maximum Conducted Transmit Power Settings

The following is a transmit power table (US domain) per dual band dipole antenna in the 5 GHz band:

20 MHZ CHANNEL	40 MHZ CHANNEL	LEGACY OFDM RATES (6,9,12,18,24,36,48,54 MBPS)	802.11n HT20 RATES (MCS 0 MCS 15)	802.11n HT40 RATES (MCS 0 MCS 15)
36		11.0	11.0	
38	(36, 40)	11.0	11.0	11.0
40		11.0	11.0	
42		11.0	11.0	
44		11.0	11.0	
46	(44, 48)	11.0	11.0	11.0
48		11.0	11.0	
52		17.0	17.0	
54	(52, 56)	17.0	17.0	16.5
56		17.0	17.0	
60		17.0	17.0	
62	(60, 64)	17.0	17.0	11.0
64		15.0	15.0	
100		12.0	15.0	
102	(100, 104)	17.0	17.0	10.0
104		17.0	17.0	
108		17.0	17.0	
112		17.0	17.0	
110	(108, 112)	17.0	17.0	17.5
116		17.0	17.0	
118	(116, 120)	17.0	17.0	14.0
120		17.0	17.0	
124		17.0	17.0	
126	(124, 128)	17.0	17.0	17.5
128		17.0	17.0	
132		17.0	17.0	
134	(132, 136)	17.0	17.0	14.0

20 MHZ CHANNEL	40 MHZ CHANNEL	LEGACY OFDM RATES (6,9,12,18,24,36,48,54 MBPS)	802.11n HT20 RATES (MCS 0 MCS 15)	802.11n HT40 RATES (MCS 0 MCS 15)
136		17.0	17.0	
140		12.0	12.0	
149		19.0	19.0	
151	(149, 153)	19.0	19.0	18.0
153		19.0	19.0	
157		19.0	19.0	
159	(157, 161)	19.0	19.0	18.0
161		19.0	19.0	
165		19.0	19.0	

Net peak gain = 5dBi

AP650 US Domain 5 GHz Internal Dual Band Antenna Maximum Conducted Transmit Power Settings

The following is a transmit power table (US domain) per internal dual band antenna in the 5 GHz band:

20 MHZ CHANNEL	40 MHZ CHANNEL	LEGACY OFDM RATES (6,9,12,18,24,36,48,54 MBPS)	802.11n HT20 RATES (MCS 0 MCS 15)	802.11n HT40 RATES (MCS 0 MCS 15)
36		11.0	11.0	
38	(36, 40)	11.0	11.0	11.0
40		11.0	11.0	
42		11.0	11.0	
44		11.0	11.0	
46	(44,48)	11.0	11.0	12.5
48		11.0	11.0	
52		17.5	17.5	
54	(52,56)	17.5	17.5	18.0
56		17.5	17.5	
60		17.5	17.5	
62	(60,64)	17.5	17.5	14.0
64		14.5	14.5	
100		17.0	17.0	
102	(100,104)	17.0	17.0	15.0
104		17.0	17.0	
108		17.0	17.0	

20 MHZ CHANNEL	40 MHZ CHANNEL	LEGACY OFDM RATES (6,9,12,18,24,36,48,54 MBPS)	802.11n HT20 RATES (MCS 0 MCS 15)	802.11n HT40 RATES (MCS 0 MCS 15)
112		17.0	17.0	
110	(108,112)	17.0	17.0	18.0
116		17.0	17.0	
118	(116,120)	17.0	17.0	18.0
120		17.0	17.0	
124		17.0	17.0	
126	(124,128)	17.0	17.0	18.0
128		17.0	17.0	
132		17.0	17.0	
134	(132,136)	17.0	17.0	17.5
136		17.0	17.0	
140		15.5	15.5	
149		19.0	19.0	
151	(149,153)	19.0	19.0	18.0
153		19.0	19.0	
157		19.0	19.0	
159	(157,161)	19.0	19.0	18.0
161		19.0	19.0	
165		19.0	19.0	

Net peak gain = 3.4dBi

AP650 US Domain 5 GHz Indoor Patch Antenna Maximum Conducted Transmit Power Settings

The following is a transmit power table (US domain) per indoor patch antenna in the 5 GHz band:

20 MHZ CHANNEL	40 MHZ CHANNEL	LEGACY OFDM RATES (6,9,12,18,24,36,48,54 MBPS)	802.11n HT20 RATES (MCS 0 MCS 15)	802.11n HT40 RATES (MCS 0 MCS 15)
36		9.5	9.5	
38	(36, 40)	10.0	10.0	10.0
40		10.0	10.0	
42		10.0	10.0	
44		10.0	10.0	
46	(44, 48)	10.0	10.0	11.0
48		10.0	10.5	

20 MHZ CHANNEL	40 MHZ CHANNEL	LEGACY OFDM RATES (6,9,12,18,24,36,48,54 MBPS)	802.11n HT20 RATES (MCS 0 MCS 15)	802.11n HT40 RATES (MCS 0 MCS 15)
52		17.5	17.5	
54	(52, 56)	17.5	17.5	17.0
56		17.5	17.5	
60		17.5	17.5	
62	(60, 64)	17.5	17.5	10.5
64		15.0	15.0	
100		12.5	12.5	
102	(100, 104)	17.0	17.5	8.0
104		17.0	17.5	
108		17.0	17.5	
112		17.0	17.5	
110	(108, 112)	17.0	17.5	16.0
116		17.0	17.5	
118	(116, 120)	17.0	17.5	16.0
120		17.0	17.5	
124		17.0	17.5	
126	(124, 128)	17.0	17.5	16.0
128		17.0	17.5	
132		17.0	17.5	
134	(132, 136)	17.0	17.5	13.0
136		17.0	17.5	
140		14.0	14.0	
149		19.0	19.0	
151	(149, 153)	19.0	19.0	18.0
153		19.0	19.0	
157		19.0	19.0	
159	(157, 161)	19.0	19.0	18.0
161		19.0	19.0	
165		19.0	19.0	

Net peak gain = 7dBi

AP650 US Domain 5 GHz Outdoor Omni Antenna Transmit Power Settings

The following is a transmit power table (US domain) per outdoor omni antenna in the 5 GHz band:

20 MHZ CHANNEL	40 MHZ CHANNEL	LEGACY OFDM RATES (6,9,12,18,24,36,48,54 MBPS)	802.11n HT20 RATES (MCS 0 MCS 15)	802.11n HT40 RATES (MCS 0 MCS 15)
36		10.0	10.0	
38	(36, 40)	10.0	10.0	10.0
40		10.0	10.0	
42		10.0	10.0	
44		10.0	10.0	
46	(44, 48)	10.0	10.0	10.0
48		10.0	10.0	
52		16.5	16.0	
54	(52, 56)	16.5	16.0	16.0
56		16.5	16.0	
60		16.0	16.0	
62	(60, 64)	15.0	16.0	14.0
64		15.0	16.0	
100		15.0	16.0	
102	(100, 104)	15.0	11.0	11.0
104		15.0	15.0	
108		15.0	15.0	
112		15.0	15.0	
110	(108, 112)	15.0	15.0	15.0
116		15.0	15.0	
118	(116, 120)	15.0	15.0	15.0
120		15.0	15.0	
124		15.0	15.0	
126	(124, 128)	15.0	15.0	5.0
128		15.0	15.0	
132		15.0	15.0	
134	(132, 136)	15.0	15.0	5.0
136		15.0	15.0	
140		12.0	12.0	
149		19.0	19.0	
151	(149, 153)	19.0	19.0	19.0
153		19.0	19.0	
157		19.0	19.0	
159	(157, 161)	19.0	19.0	19.0

20 MHZ CHANNEL	40 MHZ CHANNEL	LEGACY OFDM RATES (6,9,12,18,24,36,48,54 MBPS)	802.11n HT20 RATES (MCS 0 MCS 15)	802.11n HT40 RATES (MCS 0 MCS 15)
161		19.0	19.0	
165		19.0	19.0	

Net peak gain = 10.5dBi

AP650 US Domain 5 GHz Panel Antenna Maximum Conducted Transmit Power Settings

The following is a transmit power table (US domain) per panel antenna in the 5 GHz band:

20 MHZ CHANNEL	40 MHZ CHANNEL	LEGACY OFDM RATES (6,9,12,18,24,36,48,54 MBPS)	802.11n HT20 RATES (MCS 0 MCS 15)	802.11n HT40 RATES (MCS 0 MCS 15)
36		5.5	5.5	
38	(36, 40)	5.5	5.5	5.0
40		5.5	5.5	
42		5.5	5.5	
44		5.5	5.5	
46	(44, 48)	5.5	5.5	5.0
48		5.5	5.5	
52		12.0	12.0	
54	(52, 56)	12.0	12.0	12.0
56		12.0	12.0	
60		12.0	12.0	
62	(60, 64)	11.5	11.5	4.0
64		10.5	10.5	
100		11.0	11.0	
102	(100, 104)	11.0	11.0	3.0
104		11.0	11.0	
108		11.0	11.0	
112		11.0	11.0	
110	(108, 112)	11.0	11.0	11.0
116		11.0	11.0	
118	(116, 120)	11.0	11.0	11.5
120		11.0	11.0	
124		11.0	11.0	
126	(124, 128)	11.0	11.0	17.5

20 MHZ CHANNEL	40 MHZ CHANNEL	LEGACY OFDM RATES (6,9,12,18,24,36,48,54 MBPS)	802.11n HT20 RATES (MCS 0 MCS 15)	802.11n HT40 RATES (MCS 0 MCS 15)
128		11.0	11.0	
132		11.0	11.0	
134	(132, 136)	11.0	11.0	17.5
136		9.5	9.5	
140		9.5	9.5	
149		17.5	17.5	
151	(149, 153)	17.5	17.5	16.5
153		17.5	17.5	
157		17.5	17.5	
159	(157, 161)	17.5	17.5	16.5
161		17.5	17.5	
165		17.5	17.5	

Net peak gain = 14dBi

AP650 US Domain 5 GHz Yagi Antenna Model

The following is a transmit power table (US domain) per yagi antenna in the 5 GHz band:

20 MHZ CHANNEL	40 MHZ CHANNEL	LEGACY OFDM RATES (6,9,12,18,24,36,48,54 MBPS)	802.11n HT20 RATES (MCS 0 MCS 15)	802.11n HT40 RATES (MCS 0 MCS 15)
36		11.5	5.5	
38	(36, 40)	11.5	11.5	11.5
40		11.5	11.5	
42		11.5	11.5	
44		11.5	11.5	
46	(44, 48)	11.5	11.5	11.5
48		11.5	11.5	
52		16.0	16.0	
54	(52, 56)	16.0	16.0	16.0
56		16.0	16.0	
60		16.0	16.0	
62	(60, 64)	16.0	16.0	16.0
64		16.0	16.0	
100		16.0	16.0	

20 MHZ CHANNEL	40 MHZ CHANNEL	LEGACY OFDM RATES (6,9,12,18,24,36,48,54 MBPS)	802.11n HT20 RATES (MCS 0 MCS 15)	802.11n HT40 RATES (MCS 0 MCS 15)
102	(100, 104)	16.0	16.0	11.0
104		16.0	16.0	
108		16.0	16.0	
112		16.0	16.0	
110	(108, 112)	16.0	16.0	16.0
116		16.0	16.0	
118	(116, 120)	16.0	16.0	16.0
120		16.0	16.0	
124		16.0	16.0	
126	(124, 128)	16.0	16.0	16.0
128		16.0	16.0	
132		16.0	16.0	
134	(132, 136)	16.0	16.0	13.0
136		16.0	16.0	
140		14.0	14.0	
149		18.0	18.0	
151	(149, 153)	18.0	18.0	18.0
153		18.0	18.0	
157		18.0	18.0	
159	(157, 161)	18.0	18.0	18.0
161		18.0	18.0	
165		18.0	18.0	

Net peak gain = 10.5dBi

AP650Japan Regulatory Domain 2.4 GHz Band

AP650 Japan Domain 2.4 GHz Dipole Dual Band Antenna Maximum Conducted Transmit Power Settings

The following is a transmit power table (Japan domain) per dipole antenna in the 2.4 GHz band:

20 MHZ CHANNEL	40 MHZ CHANNEL	LEGACY DSSS RATES (1, 2, 5.5, 11 MBPS)	LEGACY OFDM RATES (6,9,12,18,24,36,48,54 MBPS)	802.11n HT20 RATES (MCS 0 MCS 15)	802.11n HT40 RATES (MCS 0 MCS15)
1		14.5	14.5	16.0	
2		14.5	14.5	15.5	
3	(1, 5)	14.5	14.5	15.5	18.5
4	(2, 6)	14.5	14.5	15.5	18.5
5	(3, 7)	14.5	14.5	15.5	18.5
6	(4, 8)	14.5	14.5	15.5	18.5
7	(5, 9)	14.5	14.5	15.5	18.5
8	(6, 10)	14.5	14.5	15.5	18.5
9	(7, 11)	14.5	14.5	15.5	18.5
10		14.5	14.5	15.5	18.5
11		14.5	14.5	15.5	18.5
12		14.5	14.5	15.5	
13		14.5	14.5	15.5	
14		14.5			

Net peak gain = 7dBi

AP650 Japan Domain 2.4 GHz Internal Dual Band Antenna Maximum Conducted Transmit Power Settings

The following is a transmit power table (Japan domain) per internal dual band antenna in the 2.4 GHz band:

20 MHZ CHANNEL	40 MHZ CHANNEL	LEGACY DSSS RATES (1, 2, 5.5, 11 MBPS)	LEGACY OFDM RATES (6,9,12,18,24,36,48,54 MBPS)	802.11n HT20 RATES (MCS 0 MCS 15)	802.11n HT40 RATES (MCS 0 MCS15)
1		19.5	19.5	19.5	
2		19.5	19.5	19.5	
3	(1, 5)	19.5	19.5	19.5	19.5
4	(2, 6)	19.5	19.5	19.5	19.5
5	(3, 7)	19.5	19.5	19.5	19.5
6	(4, 8)	19.5	19.5	19.5	19.5
7	(5, 9)	19.5	19.5	19.5	19.5
8	(6, 10)	19.5	19.5	19.5	19.5
9	(7, 11)	19.5	19.5	19.5	19.5
10		19.5	19.5	19.5	19.5

20 MHZ CHANNEL	40 MHZ CHANNEL	LEGACY DSSS RATES (1, 2, 5.5, 11 MBPS)	LEGACY OFDM RATES (6,9,12,18,24,36,48,54 MBPS)	802.11n HT20 RATES (MCS 0 MCS 15)	802.11n HT40 RATES (MCS 0 MCS15)
11		19.5	19.5	19.5	19.5
12		19.5	19.5	19.5	19.5
13		19.5	19.5	19.5	
14		19.5			

Net peak gain = 2dBi

AP650 Japan Domain 2.4 GHz Indoor Patch Antenna Maximum Conducted Transmit Power Settings

The following is a transmit power table (Japan domain) per Indoor Patch antenna in the 2.4 GHz band:

20 MHZ CHANNEL	40 MHZ CHANNEL	LEGACY DSSS RATES (1, 2, 5.5, 11 MBPS)	LEGACY OFDM RATES (6,9,12,18,24,36,48,54 MBPS)	802.11n HT20 RATES (MCS 0 MCS 15)	802.11n HT40 RATES (MCS 0 MCS15)
1		18.0	18.0	18.0	
2		18.0	18.0	18.0	
3	(1, 5)	18.0	18.0	18.0	18.0
4	(2, 6)	18.0	18.0	18.0	18.0
5	(3, 7)	18.0	18.0	18.0	18.0
6	(4, 8)	18.0	18.0	18.0	18.0
7	(5, 9)	18.0	18.0	18.0	18.0
8	(6, 10)	18.0	18.0	18.0	18.0
9	(7, 11)	18.0	18.0	18.0	18.0
10		18.0	18.0	18.0	18.0
11		18.0	18.0	18.0	18.0
12		18.0	18.0	18.0	
13		18.0	18.0	18.0	
14		18.0			

Net peak gain = 3.5dBi

AP650 Japan Domain 2.4 GHz Outdoor Omni Antenna Maximum Conducted Transmit Power Settings

The following is a transmit power table (Japan domain) per outdoor omni antenna in the 2.4 GHz band:

20 MHZ CHANNEL	40 MHZ CHANNEL	LEGACY DSSS RATES (1, 2, 5.5, 11 MBPS)	LEGACY OFDM RATES (6,9,12,18,24,36,48,54 MBPS)	802.11n HT20 RATES (MCS 0 MCS 15)	802.11n HT40 RATES (MCS0 MCS15)
1		18.0	18.0	18.0	
2		18.0	18.0	18.0	
3	(1, 5)	18.0	18.0	18.0	18.0
4	(2, 6)	18.0	18.0	18.0	18.0
5	(3, 7)	18.0	18.0	18.0	18.0
6	(4, 8)	18.0	18.0	18.0	18.0
7	(5, 9)	18.0	18.0	18.0	18.0
8	(6, 10)	18.0	18.0	18.0	18.0
9	(7, 11)	18.0	18.0	18.0	18.0
10		18.0	18.0	18.0	18.0
11		18.0	18.0	18.0	18.0
12		18.0	18.0	18.0	
13		18.0	18.0	18.0	
14		18.0			

Net peak gain = 3.3dBi

AP650 Japan Domain 2.4 GHz Panel Antenna Maximum Conducted Transmit Power Settings

The following is a transmit power table (Japan domain) per panel antenna in the 2.4 GHz band:

20 MHZ CHANNEL	40 MHZ CHANNEL	LEGACY DSSS RATES (1, 2, 5.5, 11 MBPS)	LEGACY OFDM RATES (6,9,12,18,24,36,48,54 MBPS)	802.11n HT20 RATES (MCS 0 MCS 15)	802.11n HT40 RATES (MCS0 MCS15)
1		17.0	17.0	17.0	
2		17.0	17.0	17.0	
3	(1, 5)	17.0	17.0	17.0	17.0
4	(2, 6)	17.0	17.0	17.0	17.0
5	(3, 7)	17.0	17.0	17.0	17.0
6	(4, 8)	17.0	17.0	17.0	17.0
7	(5, 9)	17.0	17.0	17.0	17.0
8	(6, 10)	17.0	17.0	17.0	17.0
9	(7, 11)	17.0	17.0	17.0	17.0
10		17.0	17.0	17.0	17.0
11		17.0	17.0	17.0	17.0

20 MHZ CHANNEL	40 MHZ CHANNEL	LEGACY DSSS RATES (1, 2, 5.5, 11 MBPS)	LEGACY OFDM RATES (6,9,12,18,24,36,48,54 MBPS)	802.11n HT20 RATES (MCS 0 MCS 15)	802.11n HT40 RATES (MCS0 MCS15)
12		17.0	17.0	17.0	
13		17.0	17.0	17.0	
14		17.0			

Net peak gain = 4.5dBi

AP650 Japan Domain 2.4 GHz Patch Antenna Maximum Conducted Transmit Power Settings

The following is a transmit power table (Japan domain) per patch antenna in the 2.4 GHz band:

20 MHZ CHANNEL	40 MHZ CHANNEL	LEGACY DSSS RATES (1, 2, 5.5, 11 MBPS)	LEGACY OFDM RATES (6,9,12,18,24,36,48,54 MBPS)	802.11n HT20 RATES (MCS 0 MCS 15)	802.11n HT40 RATES (MCS0 MCS15)
1		17.0	17.0	17.0	
2		17.0	17.0	17.0	
3	(1, 5)	17.0	17.0	17.0	17.0
4	(2, 6)	17.0	17.0	17.0	17.0
5	(3, 7)	17.0	17.0	17.0	17.0
6	(4, 8)	17.0	17.0	17.0	17.0
7	(5, 9)	17.0	17.0	17.0	17.0
8	(6, 10)	17.0	17.0	17.0	17.0
9	(7, 11)	17.0	17.0	17.0	17.0
10		17.0	17.0	17.0	17.0
11		17.0	17.0	17.0	17.0
12		17.0	17.0	17.0	
13		17.0	17.0	17.0	
14		17.0			

Net peak gain = 4dBi

AP650 Japan Regulatory Domain 5 GHz Band

The following is a transmit power table (Japan domain) per dual band dipole antenna in the 5 GHz band:

20 MHZ CHANNEL	40 MHZ CHANNEL	LEGACY OFDM RATES (6,9,12,18,24,36,48,54 MBPS)	802.11n HT20 RATES (MCS 0 MCS 15)	802.11n HT40 RATES (MCS 0 MCS 15)
36		13.0	13.0	
38	(36, 40)	13.0	13.0	13.0
40		13.0	13.0	
42		13.0	13.0	
44		13.0	13.0	
46	(44, 48)	13.0	13.0	13.0
48		13.0	13.0	
52		13.0	13.0	
54	(52, 56)	13.0	13.0	13.0
56		13.0	13.0	
60		13.0	13.0	
62	(60, 64)	13.0	13.0	13.0
64		13.0	13.0	
100		19.0	19.0	
102	(100, 104)	19.0	19.0	19.0
104		19.0	19.0	
108		19.0	19.0	
112		19.0	19.0	
110	(108, 112)	19.0	19.0	19.0
116		19.0	19.0	
118	(116, 120)	19.0	19.0	19.0
120		19.0	19.0	
124		19.0	19.0	
126	(124, 128)	19.0	19.0	19.0
128		19.0	19.0	
132		19.0	19.0	
134	(132, 136)	19.0	19.0	19.0
136		19.0	19.0	
140		19.0	19.0	
149				
151	(149, 153)			
153				
157				
159	(157, 161)			

20 MHZ CHANNEL	40 MHZ CHANNEL	LEGACY OFDM RATES (6,9,12,18,24,36,48,54 MBPS)	802.11n HT20 RATES (MCS 0 MCS 15)	802.11n HT40 RATES (MCS 0 MCS 15)
161				
165				

Net peak gain = 7dBi

AP650 Japan Domain 5 GHz Internal Dual Band Antenna Maximum Conducted Transmit Power Settings

The following is a transmit power table (Japan domain) per internal dual band antenna in the 5 GHz band:

20 MHZ CHANNEL	40 MHZ CHANNEL	LEGACY OFDM RATES (6,9,12,18,24,36,48,54 MBPS)	802.11n HT20 RATES (MCS 0 MCS 15)	802.11n HT40 RATES (MCS 0 MCS 15)
36		14.0	14.0	
38	(36, 40)	14.0	14.0	14.0
40		14.0	14.0	
42		14.0	14.0	
44		14.0	14.0	
46	(44,48)	14.0	14.0	14.0
48		14.0	14.0	
52		14.0	14.0	
54	(52,56)	14.0	14.0	14.0
56		14.0	14.0	
60		14.0	14.0	
62	(60,64)	14.0	14.0	14.0
64		14.0	14.0	
100		19.0	19.0	
102	(100,104)	19.0	19.0	19.0
104		19.0	19.0	
108		19.0	19.0	
112		19.0	19.0	
110	(108,112)	19.0	19.0	19.0
116		19.0	19.0	
118	(116,120)	19.0	19.0	19.0
120		19.0	19.0	
124		19.0	19.0	

20 MHZ CHANNEL	40 MHZ CHANNEL	LEGACY OFDM RATES (6,9,12,18,24,36,48,54 MBPS)	802.11n HT20 RATES (MCS 0 MCS 15)	802.11n HT40 RATES (MCS 0 MCS 15)
126	(124,128)	19.0	19.0	19.0
128		19.0	19.0	
132		19.0	19.0	
134	(132,136)	19.0	19.0	19.0
136		19.0	19.0	
140		19.0	19.0	
149				
151	(149,153)			
153				
157				
159	(157,161)			
161				
165				

Net peak gain = 3.4dBi

AP650 Japan Domain 5 GHz Indoor Patch Antenna Maximum Conducted Transmit Power Settings

The following is a transmit power table (Japan domain) per indoor patch antenna in the 5 GHz band:

20 MHZ CHANNEL	40 MHZ CHANNEL	LEGACY OFDM RATES (6,9,12,18,24,36,48,54 MBPS)	802.11n HT20 RATES (MCS 0 MCS 15)	802.11n HT40 RATES (MCS 0 MCS 15)
36		14.5	14.5	
38	(36, 40)	14.5	14.5	14.5
40		14.5	14.5	
42		14.5	14.5	
44		14.5	14.5	
46	(44, 48)	14.5	14.5	14.5
48		14.5	14.5	
52		14.5	14.5	
54	(52, 56)	14.5	14.5	14.5
56		14.5	14.5	
60		14.5	14.5	
62	(60, 64)	14.5	14.5	14.5
64		14.5	14.5	

20 MHZ CHANNEL	40 MHZ CHANNEL	LEGACY OFDM RATES (6,9,12,18,24,36,48,54 MBPS)	802.11n HT20 RATES (MCS 0 MCS 15)	802.11n HT40 RATES (MCS 0 MCS 15)
100		19.0	19.0	
102	(100, 104)	19.0	19.0	19.0
104		19.0	19.0	
108		19.0	19.0	
112		19.0	19.0	
110	(108, 112)	19.0	19.0	19.0
116		19.0	19.0	
118	(116, 120)	19.0	19.0	19.0
120		19.0	19.0	
124		19.0	19.0	
126	(124, 128)	19.0	19.0	19.0
128		19.0	19.0	
132		19.0	19.0	
134	(132, 136)	19.0	19.0	19.0
136		19.0	19.0	
140		19.0	19.0	
149				
151	(149, 153)			
153				
157				
159	(157, 161)			
161				
165				

Net peak gain = 3dBi

AP650 Japan Domain 5 GHz Outdoor Omni Antenna Transmit Power Settings

The following is a transmit power table (Japan domain) per outdoor omni antenna in the 5 GHz band:

20 MHZ CHANNEL	40 MHZ CHANNEL	LEGACY OFDM RATES (6,9,12,18,24,36,48,54 MBPS)	802.11n HT20 RATES (MCS 0 MCS 15)	802.11n HT40 RATES (MCS 0 MCS 15)
36		18.0	18.0	
38	(36, 40)	18.0	18.0	18.0
40		18.0	18.0	

20 MHZ CHANNEL	40 MHZ CHANNEL	LEGACY OFDM RATES (6,9,12,18,24,36,48,54 MBPS)	802.11n HT20 RATES (MCS 0 MCS 15)	802.11n HT40 RATES (MCS 0 MCS 15)
42		18.0	18.0	
44		18.0	18.0	
46	(44, 48)	18.0	18.0	18.0
48		18.0	18.0	
52		18.0	18.0	
54	(52, 56)	18.0	18.0	18.0
56		18.0	18.0	
60		18.0	18.0	
62	(60, 64)	18.0	18.0	18.0
64		18.0	18.0	
100		19.0	19.0	
102	(100, 104)	19.0	19.0	19.0
104		19.0	19.0	
108		19.0	19.0	
112		19.0	19.0	
110	(108, 112)	19.0	19.0	19.0
116		19.0	19.0	
118	(116, 120)	19.0	19.0	19.0
120		19.0	19.0	
124		19.0	19.0	
126	(124, 128)	19.0	19.0	19.0
128		19.0	19.0	
132		19.0	19.0	
134	(132, 136)	19.0	19.0	19.0
136		19.0	19.0	
140		19.0	19.0	
149				
151	(149, 153)			
153				
157				
159	(157, 161)			
161				
165				

Net peak gain = 4.2dBi

AP650 Japan Domain 5 GHz Panel Antenna Maximum Conducted Transmit Power Settings

The following is a transmit power table (Japan domain) per panel antenna in the 5 GHz band:

20 MHZ CHANNEL	40 MHZ CHANNEL	LEGACY OFDM RATES (6,9,12,18,24,36,48,54 MBPS)	802.11n HT20 RATES (MCS 0 MCS 15)	802.11n HT40 RATES (MCS 0 MCS 15)
36		18.0	18.0	
38	(36, 40)	18.0	18.0	18.0
40		18.0	18.0	
42		18.0	18.0	
44		18.0	18.0	
46	(44, 48)	18.0	18.0	18.0
48		18.0	18.0	
52		18.0	18.0	
54	(52, 56)	18.0	18.0	18.0
56		18.0	18.0	
60		18.0	18.0	
62	(60, 64)	18.0	18.0	18.0
64		18.0	18.0	
100		19.0	19.0	
102	(100, 104)	19.0	19.0	19.0
104		19.0	19.0	
108		19.0	19.0	
112		19.0	19.0	
110	(108, 112)	19.0	19.0	19.0
116		19.0	19.0	
118	(116, 120)	19.0	19.0	19.0
120		19.0	19.0	
124		19.0	19.0	
126	(124, 128)	19.0	19.0	19.0
128		19.0	19.0	
132		19.0	19.0	
134	(132, 136)	19.0	19.0	19.0
136		19.0	19.0	
140		19.0	19.0	
149				

20 MHZ CHANNEL	40 MHZ CHANNEL	LEGACY OFDM RATES (6,9,12,18,24,36,48,54 MBPS)	802.11n HT20 RATES (MCS 0 MCS 15)	802.11n HT40 RATES (MCS 0 MCS 15)
151	(149, 153)			
153				
157				
159	(157, 161)			
161				
165				

Net peak gain = 5dBi

AP650 Japan Domain 5 GHz Patch Antenna Maximum Conducted Transmit Power Settings

The following is a transmit power table (Japan domain) per patch antenna in the 5 GHz band:

20 MHZ CHANNEL	40 MHZ CHANNEL	LEGACY OFDM RATES (6,9,12,18,24,36,48,54 MBPS)	802.11n HT20 RATES (MCS 0 MCS 15)	802.11n HT40 RATES (MCS 0 MCS 15)
36		16.0	16.0	
38	(36, 40)	16.0	16.0	16.0
40		16.0	16.0	
42		16.0	16.0	
44		16.0	16.0	
46	(44, 48)	16.0	16.0	16.0
48		16.0	16.0	
52		16.0	16.0	
54	(52, 56)	16.0	16.0	16.0
56		16.0	16.0	
60		16.0	16.0	
62	(60, 64)	16.0	16.0	16.0
64		16.0	16.0	
100		19.0	19.0	
102	(100, 104)	19.0	19.0	19.0
104		19.0	19.0	
108		19.0	19.0	
112		19.0	19.0	
110	(108, 112)	19.0	19.0	19.0
116		19.0	19.0	

20 MHZ CHANNEL	40 MHZ CHANNEL	LEGACY OFDM RATES (6,9,12,18,24,36,48,54 MBPS)	802.11n HT20 RATES (MCS 0 MCS 15)	802.11n HT40 RATES (MCS 0 MCS 15)
118	(116, 120)	19.0	19.0	19.0
120		19.0	19.0	
124		19.0	19.0	
126	(124, 128)	19.0	19.0	19.0
128		19.0	19.0	
132		19.0	19.0	
134	(132, 136)	19.0	19.0	19.0
136		19.0	19.0	
140		19.0	19.0	
149				
151	(149, 153)			
153				
157				
159	(157, 161)			
161				
165				

Net peak gain = 7dBi

AP650 EU Regulatory Domain 2.4 GHz Band

The following is a transmit power table (EU domain) per dipole antenna in the 2.4 GHz band:

20 MHZ CHANNEL	40 MHZ CHANNEL	LEGACY DSSS RATES (1, 2, 5.5, 11 MBPS)	LEGACY OFDM RATES (6,9,12,18,24,36,48,54 MBPS)	802.11n HT20 RATES (MCS 0 MCS 15)	802.11n HT40 RATES (MCS 0 MCS15)
1		10.0	10.0	10.0	
2		10.0	10.0	10.0	
3	(1, 5)	10.0	10.0	10.0	10.0
4	(2, 6)	10.0	10.0	10.0	10.0
5	(3, 7)	10.0	10.0	10.0	10.0
6	(4, 8)	10.0	10.0	10.0	10.0
7	(5, 9)	10.0	10.0	10.0	10.0
8	(6, 10)	10.0	10.0	10.0	10.0
9	(7, 11)	10.0	10.0	10.0	10.0
10	(8, 12)	10.0	10.0	10.0	10.0

20 MHZ CHANNEL	40 MHZ CHANNEL	LEGACY DSSS RATES (1, 2, 5.5, 11 MBPS)	LEGACY OFDM RATES (6,9,12,18,24,36,48,54 MBPS)	802.11n HT20 RATES (MCS 0 MCS 15)	802.11n HT40 RATES (MCS 0 MCS15)
11	(9, 13)	10.0	10.0	10.0	10.0
12		10.0	10.0	10.0	
13		10.0	10.0	10.0	

Net peak gain = 7dBi

AP650 EU Domain 2.4 GHz Internal Dual Band Antenna Maximum Conducted Transmit Power Settings

The following is a transmit power table (EU domain) per internal dual band antenna in the 2.4 GHz band:

20 MHZ CHANNEL	40 MHZ CHANNEL	LEGACY DSSS RATES (1, 2, 5.5, 11 MBPS)	LEGACY OFDM RATES (6,9,12,18,24,36,48,54 MBPS)	802.11n HT20 RATES (MCS 0 MCS 15)	802.11n HT40 RATES (MCS 0 MCS15)
1		15.0	15.0	15.0	
2		15.0	15.0	15.0	
3	(1, 5)	15.0	15.0	15.0	15.0
4	(2, 6)	15.0	15.0	15.0	15.0
5	(3, 7)	15.0	15.0	15.0	15.0
6	(4, 8)	15.0	15.0	15.0	15.0
7	(5, 9)	15.0	15.0	15.0	15.0
8	(6, 10)	15.0	15.0	15.0	15.0
9	(7, 11)	15.0	15.0	15.0	15.0
10	(8, 12)	15.0	15.0	15.0	15.0
11	(9, 13)	15.0	15.0	15.0	15.0
12		15.0	15.0	15.0	
13		15.0	15.0	15.0	

Net peak gain = 2dBi

AP650 EU Domain 2.4 GHz Outdoor Omni Antenna Maximum Conducted Transmit Power Settings

The following is a transmit power table (EU domain) per outdoor omni antenna in the 2.4 GHz band:

20 MHZ CHANNEL	40 MHZ CHANNEL	LEGACY DSSS RATES (1, 2, 5.5, 11 MBPS)	LEGACY OFDM RATES (6,9,12,18,24,36,48,54 MBPS)	802.11n HT20 RATES (MCS 0 MCS 15)	802.11n HT40 RATES (MCS0 MCS15)
1		13.5	13.5	13.5	
2		13.5	13.5	13.5	
3	(1, 5)	13.5	13.5	13.5	13.5
4	(2, 6)	13.5	13.5	13.5	13.5
5	(3, 7)	13.5	13.5	13.5	13.5
6	(4, 8)	13.5	13.5	13.5	13.5
7	(5, 9)	13.5	13.5	13.5	13.5
8	(6, 10)	13.5	13.5	13.5	13.5
9	(7, 11)	13.5	13.5	13.5	13.5
10	(8, 12)	13.5	13.5	13.5	13.5
11	(9, 13)	13.5	13.5	13.5	13.5
12		13.5	13.5	13.5	
13		13.5	13.5	13.5	

Net peak gain = 3.3dBi

AP650 EU Domain 2.4 GHz Panel Antenna Maximum Conducted Transmit Power Settings

The following is a transmit power table (EU domain) per panel antenna in the 2.4 GHz band:

20 MHZ CHANNEL	40 MHZ CHANNEL	LEGACY DSSS RATES (1, 2, 5.5, 11 MBPS)	LEGACY OFDM RATES (6,9,12,18,24,36,48,54 MBPS)	802.11n HT20 RATES (MCS 0 MCS 15)	802.11n HT40 RATES (MCS0 MCS15)
1		12.5	12.5	13.0	
2		12.5	12.5	12.5	
3	(1, 5)	12.5	12.5	12.5	12.5
4	(2, 6)	12.5	12.5	12.5	12.5
5	(3, 7)	12.5	12.5	12.5	12.5
6	(4, 8)	12.5	12.5	12.5	12.5
7	(5, 9)	12.5	12.5	12.5	12.5
8	(6, 10)	12.5	12.5	12.5	12.5
9	(7, 11)	12.5	12.5	12.5	12.5
10	(8, 12)	12.5	12.5	12.5	12.5
11	(9, 13)	12.5	12.5	12.5	12.5

20 MHZ CHANNEL	40 MHZ CHANNEL	LEGACY DSSS RATES (1, 2, 5.5, 11 MBPS)	LEGACY OFDM RATES (6,9,12,18,24,36,48,54 MBPS)	802.11n HT20 RATES (MCS 0 MCS 15)	802.11n HT40 RATES (MCS0 MCS15)
12		12.5	12.5	12.5	
13		12.5	12.5	12.5	

Net peak gain = 4.5dBi

AP650 EU Domain 2.4 GHz Patch Antenna Maximum Conducted Transmit Power Settings

The following is a transmit power table (EU domain) per patch antenna in the 2.4 GHz band:

20 MHZ CHANNEL	40 MHZ CHANNEL	LEGACY DSSS RATES (1, 2, 5.5, 11 MBPS)	LEGACY OFDM RATES (6,9,12,18,24,36,48,54 MBPS)	802.11n HT20 RATES (MCS 0 MCS 15)	802.11n HT40 RATES (MCS0 MCS15)
1		13.0	13.0	13.0	
2		13.0	13.0	13.0	
3	(1, 5)	13.0	13.0	13.0	13.0
4	(2, 6)	13.0	13.0	13.0	13.0
5	(3, 7)	13.0	13.0	13.0	13.0
6	(4, 8)	13.0	13.0	13.0	13.0
7	(5, 9)	13.0	13.0	13.0	13.0
8	(6, 10)	13.0	13.0	13.0	13.0
9	(7, 11)	13.0	13.0	13.0	13.0
10	(8, 12)	13.0	13.0	13.0	13.0
11	(9, 13)	13.0	13.0	13.0	13.0
12		13.0	13.0	13.0	
13		13.0	13.0	13.0	

Net peak gain = 4dBi

AP650 EU Regulatory Domain 5 GHz Band

AP650 EU Domain 5 GHz Dual Band Dipole Antenna Maximum Conducted Transmit Power Settings

The following is a transmit power table (EU domain) per dual band dipole antenna in the 5 GHz band:

20 MHZ CHANNEL	40 MHZ CHANNEL	LEGACY OFDM RATES (6,9,12,18,24,36,48,54 MBPS)	802.11n HT20 RATES (MCS 0 MCS 15)	802.11n HT40 RATES (MCS 0 MCS 15)
36		15.0	15.0	
38	(36, 40)	15.0	15.0	13.0
40		15.0	15.0	
42		15.0	15.0	
44		15.0	15.0	
46	(44, 48)	15.0	15.0	13.0
48		15.0	15.0	
52		15.0	15.0	
54	(52, 56)	15.0	15.0	15.0
56		15.0	15.0	
60		15.0	15.0	
62	(60, 64)	15.0	15.0	15.0
64		15.0	15.0	
100		19.0	19.0	
102	(100, 104)	19.0	19.0	19.0
104		19.0	19.0	
108		19.0	19.0	
112		19.0	19.0	
110	(108, 112)	19.0	19.0	19.0
116		19.0	19.0	
118	(116, 120)	19.0	19.0	19.0
120		19.0	19.0	
124		19.0	19.0	
126	(124, 128)	19.0	19.0	19.0
128		19.0	19.0	
132		19.0	19.0	
134	(132, 136)	19.0	19.0	19.0
136		19.0	19.0	
140		19.0	19.0	
149				
151	(149, 153)			
153				
157				
159	(157, 161)			

20 MHZ CHANNEL	40 MHZ CHANNEL	LEGACY OFDM RATES (6,9,12,18,24,36,48,54 MBPS)	802.11n HT20 RATES (MCS 0 MCS 15)	802.11n HT40 RATES (MCS 0 MCS 15)
161				
165				

Net peak gain = 5dBi

AP650 EU Domain 5 GHz Internal Dual Band Antenna Maximum Conducted Transmit Power Settings

The following is a transmit power table (EU domain) per internal dual band antenna in the 5 GHz band:

20 MHZ CHANNEL	40 MHZ CHANNEL	LEGACY OFDM RATES (6,9,12,18,24,36,48,54 MBPS)	802.11n HT20 RATES (MCS 0 MCS 15)	802.11n HT40 RATES (MCS 0 MCS 15)
36		16.0	16.0	
38	(36, 40)	16.0	16.0	16.0
40		16.0	16.0	
42		16.0	16.0	
44		16.0	16.0	
46	(44,48)	16.0	16.0	16.0
48		16.0	16.0	
52		16.0	16.0	
54	(52,56)	16.0	16.0	16.0
56		16.0	16.0	
60		16.0	16.0	
62	(60,64)	16.0	16.0	16.0
64		16.0	16.0	
100		18.0	18.0	
102	(100,104)	18.0	18.0	18.0
104		18.0	18.0	
108		18.0	18.0	
112		18.0	18.0	
110	(108,112)	18.0	18.0	18.0
116		18.0	18.0	
118	(116,120)	18.0	18.0	18.0
120		18.0	18.0	
124		18.0	18.0	
126	(124,128)	18.0	18.0	18.0

20 MHZ CHANNEL	40 MHZ CHANNEL	LEGACY OFDM RATES (6,9,12,18,24,36,48,54 MBPS)	802.11n HT20 RATES (MCS 0 MCS 15)	802.11n HT40 RATES (MCS 0 MCS 15)
128		18.0	18.0	
132		18.0	18.0	
134	(132,136)	18.0	18.0	18.0
136		18.0	18.0	
140		18.0	18.0	
149				
151	(149,153)			
153				
157				
159	(157,161)			
161				
165				

Net peak gain = 4.8dBi

AP650 EU Domain 5 GHz Indoor Patch Antenna Maximum Conducted Transmit Power Settings

The following is a transmit power table (EU domain) per indoor patch antenna in the 5 GHz band:

20 MHZ CHANNEL	40 MHZ CHANNEL	LEGACY OFDM RATES (6,9,12,18,24,36,48,54 MBPS)	802.11n HT20 RATES (MCS 0 MCS 15)	802.11n HT40 RATES (MCS 0 MCS 15)
36		13.0	13.0	
38	(36, 40)	13.0	13.0	13.0
40		13.0	13.0	
42		13.0	13.0	
44		13.0	13.0	
46	(44, 48)	13.0	13.0	13.0
48		13.0	13.0	
52		13.0	13.0	
54	(52, 56)	13.0	13.0	13.0
56		13.0	13.0	
60		13.0	13.0	
62	(60, 64)	13.0	13.0	13.0
64		13.0	13.0	
100		19.0	19.0	

20 MHZ CHANNEL	40 MHZ CHANNEL	LEGACY OFDM RATES (6,9,12,18,24,36,48,54 MBPS)	802.11n HT20 RATES (MCS 0 MCS 15)	802.11n HT40 RATES (MCS 0 MCS 15)
102	(100, 104)	19.0	19.0	19.0
104		19.0	19.0	
108		19.0	19.0	
112		19.0	19.0	
110	(108, 112)	19.0	19.0	19.0
116		19.0	19.0	
118	(116, 120)	19.0	19.0	19.0
120		19.0	19.0	
124		19.0	19.0	
126	(124, 128)	19.0	19.0	19.0
128		19.0	19.0	
132		19.0	19.0	
134	(132, 136)	19.0	19.0	19.0
136		19.0	19.0	
140		19.0	19.0	
149				
151	(149, 153)			
153				
157				
159	(157, 161)			
161				
165				

Net peak gain = 7dBi

AP650 EU Domain 5 GHz Outdoor Omni Antenna Transmit Power Settings

The following is a transmit power table (EU domain) per outdoor omni antenna in the 5 GHz band:

20 MHZ CHANNEL	40 MHZ CHANNEL	LEGACY OFDM RATES (6,9,12,18,24,36,48,54 MBPS)	802.11n HT20 RATES (MCS 0 MCS 15)	802.11n HT40 RATES (MCS 0 MCS 15)
36		15.5	15.5	
38	(36, 40)	15.5	15.5	15.5
40		15.5	15.5	
42		15.5	15.5	

20 MHZ CHANNEL	40 MHZ CHANNEL	LEGACY OFDM RATES (6,9,12,18,24,36,48,54 MBPS)	802.11n HT20 RATES (MCS 0 MCS 15)	802.11n HT40 RATES (MCS 0 MCS 15)
44		15.5	15.5	
46	(44, 48)	15.5	15.5	15.5
48		15.5	15.5	
52		15.5	15.5	
54	(52, 56)	15.5	15.5	15.5
56		15.5	15.5	
60		15.5	15.5	
62	(60, 64)	15.5	15.5	15.5
64		15.5	15.5	
100		19.0	19.0	
102	(100, 104)	19.0	19.0	19.0
104		19.0	19.0	
108		19.0	19.0	
112		19.0	19.0	
110	(108, 112)	19.0	19.0	19.0
116		19.0	19.0	
118	(116, 120)	19.0	19.0	19.0
120		19.0	19.0	
124		19.0	19.0	
126	(124, 128)	19.0	19.0	19.0
128		19.0	19.0	
132		19.0	19.0	
134	(132, 136)	19.0	19.0	19.0
136		19.0	19.0	
140		19.0	19.0	
149				
151	(149, 153)			
153				
157				
159	(157, 161)			
161				
165				

Net peak gain = 4.2dBi

AP650 EU Domain 5 GHz Panel Antenna Maximum Conducted Transmit Power Settings

The following is a transmit power table (Japan domain) per panel antenna in the 5 GHz band:

20 MHZ CHANNEL	40 MHZ CHANNEL	LEGACY OFDM RATES (6,9,12,18,24,36,48,54 MBPS)	802.11n HT20 RATES (MCS 0 MCS 15)	802.11n HT40 RATES (MCS 0 MCS 15)
36		15.0	15.0	
38	(36, 40)	15.0	15.0	15.0
40		15.0	15.0	
42		15.0	15.0	
44		15.0	15.0	
46	(44, 48)	15.0	15.0	15.0
48		15.0	15.0	
52		15.0	15.0	
54	(52, 56)	15.0	15.0	15.0
56		15.0	15.0	
60		15.0	15.0	
62	(60, 64)	15.0	15.0	15.0
64		15.0	15.0	
100		19.0	19.0	
102	(100, 104)	19.0	19.0	19.0
104		19.0	19.0	
108		19.0	19.0	
112		19.0	19.0	
110	(108, 112)	19.0	19.0	19.0
116		19.0	19.0	
118	(116, 120)	19.0	19.0	19.0
120		19.0	19.0	
124		19.0	19.0	
126	(124, 128)	19.0	19.0	19.0
128		19.0	19.0	
132		19.0	19.0	
134	(132, 136)	19.0	19.0	19.0
136		19.0	19.0	
140		19.0	19.0	
149				
151	(149, 153)			
153				

20 MHZ CHANNEL	40 MHZ CHANNEL	LEGACY OFDM RATES (6,9,12,18,24,36,48,54 MBPS)	802.11n HT20 RATES (MCS 0 MCS 15)	802.11n HT40 RATES (MCS 0 MCS 15)
157				
159	(157, 161)			
161				
165				

Net peak gain = 5dBi

12 RFS4011 Regulatory Domains

RFS4011 US Regulatory Domain 2.4 GHz Band
 RFS4011 US Regulatory Domain 5 GHz Band
 RFS4011 Canada Regulatory Domain 2.4 GHz Band
 RFS4011 Canada Regulatory Domain 5 GHz Band
 RFS4011 EU Regulatory Domain 2.4 GHz Band
 RFS4011 EU Regulatory Domain 5 GHz Band
 RFS4011 Japan Regulatory Domain 2.4 GHz Band
 RFS4011 Japan Regulatory Domain 5 GHz Band

RFS4011 US Regulatory Domain 2.4 GHz Band

RFS4011 US Domain 2.4 GHz Facade Antenna Model

The following is the RFS4011 facade antenna model for 2.4 GHz, its peak gain is 2.1dBi:

Part Number
ML-2452-PTA4M3X3-1

RFS4011 US Domain 2.4 GHz Facade Antenna Maximum Conducted Transmit Power Settings

The following is a transmit power table (US domain) per facade antenna in the 2.4 GHz band:

20 MHZ CHANNEL	40 MHZ CHANNEL	LEGACY DSSS RATES (1, 2, 5.5, 11 MBPS)	LEGACY OFDM RATES (6,9,12,18,24,36,48,54 MBPS)	802.11n HT20 RATES (MCS 0 MCS 15)	802.11n HT40 RATES (MCS 0 MCS15)
1		18.5	15.0	15.5	
2		18.5	15.0	15.5	
3	(1, 5)	18.5	15.0	15.5	12.5
4	(2, 6)	18.5	15.0	15.5	12.5
5	(3, 7)	18.5	15.0	15.5	12.5
6	(4, 8)	21.0	15.0	16.0	15.5
7	(5, 9)	20.0	15.5	15.5	12.5
8	(6, 10)	20.0	15.5	15.5	12.5
9	(7, 11)	20.0	15.5	15.5	12.5

20 MHZ CHANNEL	40 MHZ CHANNEL	LEGACY DSSS RATES (1, 2, 5.5, 11 MBPS)	LEGACY OFDM RATES (6,9,12,18,24,36,48,54 MBPS)	802.11n HT20 RATES (MCS 0 MCS 15)	802.11n HT40 RATES (MCS 0 MCS15)
10		20.0	15.5	15.5	
11		20.0	15.5	15,5	

RFS4011 US Domain 2.4 GHz MIMO Patch Antenna Model

The following is the RFS4011 MIMO patch antenna model for 2.4 GHz, its peak gain is 3.5dBi:

Part Number
ML-2452-PTA3M3-036

RFS4011 US Domain 2.4 GHz MIMO Patch Antenna Maximum Conducted Transmit Power Settings

The following is a transmit power table (US domain) per MIMO patch antenna in the 2.4 GHz band:

20 MHZ CHANNEL	40 MHZ CHANNEL	LEGACY DSSS RATES (1, 2, 5.5, 11 MBPS)	LEGACY OFDM RATES (6,9,12,18,24,36,48,54 MBPS)	802.11n HT20 RATES (MCS 0 MCS 15)	802.11n HT40 RATES (MCS 0 MCS15)
1		18.5	13.5	14.5	
2		18.5	13.5	14.5	
3	(1, 5)	18.5	13.5	14.5	11.5
4	(2, 6)	18.5	13.5	14.5	11.5
5	(3, 7)	18.5	13.5	14.5	11.5
6	(4, 8)	19.5	14.0	16.0	15.5
7	(5, 9)	19.0	14.0	14.5	11.5
8	(6, 10)	19.0	14.0	14.5	11.5
9	(7, 11)	19.0	14.0	14.5	11.5
10		19.0	14.0	14.5	
11		19.0	14.0	14.5	

RFS4011 US Domain 2.4 GHz Dipole Antenna Model

The following is the RFS4011 dipole antenna model for 2.4 GHz, its peak gain is 3.1dBi:

Part Number
ML-2452-HPA5-036

RFS4011 US Domain 2.4 GHz Dipole Antenna Maximum Conducted Transmit Power Settings

The following is a transmit power table (US domain) per dipole antenna in the 2.4 GHz band:

20 MHZ CHANNEL	40 MHZ CHANNEL	LEGACY DSSS RATES (1, 2, 5.5, 11 MBPS)	LEGACY OFDM RATES (6,9,12,18,24,36,48,54 MBPS)	802.11n HT20 RATES (MCS 0 MCS 15)	802.11n HT40 RATES (MCS 0 MCS15)
1		19.0	14.0	14.0	
2		19.0	14.0	14.0	
3	(1, 5)	19.0	14.0	14.0	11.0
4	(2, 6)	19.0	14.0	14.0	11.0
5	(3, 7)	19.0	14.0	14.0	11.0
6	(4, 8)	20.0	15.0	15.5	14.0
7	(5, 9)	18.5	13.5	13.5	11.0
8	(6, 10)	18.5	13.5	13.5	11.0
9	(7, 11)	18.5	13.5	13.5	11.0
10		18.5	13.5	13.5	
11		18.5	13.5	13.5	

RFS4011 US Domain 2.4 GHz High-Gain Patch Antenna Model

The following is the RFS4011 high-gain patch antenna model for 2.4 GHz, its peak gain is 7.5 dBi:

Part Number
ML-2452-PNA7-01R

RFS4011 US Domain 2.4 GHz High-Gain Patch Antenna Maximum Conducted Transmit Power Settings

The following is a transmit power table (US domain) per high-gain patch antenna in the 2.4 GHz band:

20 MHZ CHANNEL	40 MHZ CHANNEL	LEGACY DSSS RATES (1, 2, 5.5, 11 MBPS)	LEGACY OFDM RATES (6,9,12,18,24,36,48,54 MBPS)	802.11n HT20 RATES (MCS 0 MCS 15)	802.11n HT40 RATES (MCS0 MCS15)
1		15.5	9.5	11.0	
2		15.5	9.5	11.0	
3	(1, 5)	15.5	9.5	11.0	7.5
4	(2, 6)	15.5	9.5	11.0	7.5
5	(3, 7)	15.5	9.5	11.0	7.5
6	(4, 8)	15.5	10.5	15.0	12.5

20 MHZ CHANNEL	40 MHZ CHANNEL	LEGACY DSSS RATES (1, 2, 5.5, 11 MBPS)	LEGACY OFDM RATES (6,9,12,18,24,36,48,54 MBPS)	802.11n HT20 RATES (MCS 0 MCS 15)	802.11n HT40 RATES (MCS0 MCS15)
7	(5, 9)	16.0	9.5	11.0	8.0
8	(6, 10)	16.0	9.5	11.0	8.0
9	(7, 11)	16.0	9.5	11.0	8.0
10		16.0	9.5	11.0	
11		16.0	9.5	11.0	

RFS4011 US Regulatory Domain 5 GHz Band

RFS4011 US Domain 5 GHz Facade Antenna Model

The following is the RFS4011 facade antenna model for 5 GHz, its peak gain is 3.95dBi:

Part Number
ML-2452-PTA4M3X3-1

RFS4011 US Domain 5 GHz Facade Antenna Maximum Conducted Transmit Power Settings

The following is a transmit power table (US domain) per facade antenna in the 5 GHz band:

20 MHZ CHANNEL	40 MHZ CHANNEL	LEGACY OFDM RATES (6,9,12,18,24,36,48,54 MBPS)	802.11n HT20 RATES (MCS 0 MCS 15)	802.11n HT40 RATES (MCS 0 MCS 15)
36		8.5	10.0	
38	(36, 40)			10.0
40		8.5	10.0	
42		8.5	10.0	
44		8.5	10.0	
46	(44, 48)			10.0
48		8.5	10.0	
52				
54	(52, 56)			
56				
60				
62	(60, 64)			
64				
100				

20 MHZ CHANNEL	40 MHZ CHANNEL	LEGACY OFDM RATES (6,9,12,18,24,36,48,54 MBPS)	802.11n HT20 RATES (MCS 0 MCS 15)	802.11n HT40 RATES (MCS 0 MCS 15)
102	(100, 104)			
104				
108				
112				
110	(108, 112)			
116				
118	(116, 120)			
120				
124				
126	(124, 128)			
128				
132				
134	(132, 136)			
136				
140				
149		11.0	12.5	
151	(149, 153)			12.5
153		11.0	12.5	
157		11.5	12.5	
159	(157, 161)			13.0
161		12.0	13.0	
165		12.0	13.0	

RFS4011 US Domain 5 GHz MIMO Patch Antenna Model

The following is the RFS4011 MIMO patch antenna model for 5 GHz, its peak gain is 5.0dBi:

Part Number
ML-2452-PTA3M3-036

RFS4011 US Domain 5 GHz MIMO Patch Antenna Maximum Conducted Transmit Power Settings

The following is a transmit power table (US domain) per MIMO patch antenna in the 5 GHz band:

20 MHZ CHANNEL	40 MHZ CHANNEL	LEGACY OFDM RATES (6,9,12,18,24,36,48,54 MBPS)	802.11n HT20 RATES (MCS 0 MCS 15)	802.11n HT40 RATES (MCS 0 MCS 15)
36		7.5	11.0	
38	(36, 40)			11.0
40		7.5	11.0	
42		7.5	11.0	
44		7.5	11.0	
46	(44,48)			11.0
48		7.5	11.0	
52				
54	(52,56)			
56				
60				
62	(60,64)			
64				
100				
102	(100,104)			
104				
108				
112				
110	(108,112)			
116				
118	(116,120)			
120				
124				
126	(124,128)			
128				
132				
134	(132,136)			
136				
140				
149		10.5	13.5	
151	(149,153)			13.5
153		10.5	13.5	
157		11.0	13.5	
159	(157,161)			14.0

20 MHZ CHANNEL	40 MHZ CHANNEL	LEGACY OFDM RATES (6,9,12,18,24,36,48,54 MBPS)	802.11n HT20 RATES (MCS 0 MCS 15)	802.11n HT40 RATES (MCS 0 MCS 15)
161		11.5	14.0	
165		11.5	14.0	

RFS4011 US Domain 5 GHz Dipole Model

The following is the RFS4011 dipole antenna model for 5 GHz, its peak gain is 4.6dBi:

Part Number
ML-2452-HPA5-036

RFS4011 US Domain 5 GHz Dipole Antenna Maximum Conducted Transmit Power Settings

The following is a transmit power table (US domain) per dipole antenna in the 5 GHz band:

20 MHZ CHANNEL	40 MHZ CHANNEL	LEGACY OFDM RATES (6,9,12,18,24,36,48,54 MBPS)	802.11n HT20 RATES (MCS 0 MCS 15)	802.11n HT40 RATES (MCS 0 MCS 15)
36		8.0	11.0	
38	(36, 40)			11.0
40		8.0	11.0	
42		8.0	11.0	
44		8.0	11.0	
46	(44, 48)			11.0
48		8.0	11.0	
52				
54	(52, 56)			
56				
60				
62	(60, 64)			
64				
100				
102	(100, 104)			
104				
108				
112				
110	(108, 112)			
116				

20 MHZ CHANNEL	40 MHZ CHANNEL	LEGACY OFDM RATES (6,9,12,18,24,36,48,54 MBPS)	802.11n HT20 RATES (MCS 0 MCS 15)	802.11n HT40 RATES (MCS 0 MCS 15)
118	(116, 120)			
120				
124				
126	(124, 128)			
128				
132				
134	(132, 136)			
136				
140				
149		10.5	13.5	
151	(149, 153)			13.5
153		10.5	13.5	
157		11.0	13.5	
159	(157, 161)			14.0
161		11.5	14.0	
165		11.5	14.0	

RFS4011 US Domain 5 GHz High-Gain Patch Antenna Model

The following is the RFS4011 high-gain patch antenna model for 5 GHz, its peak gain is between 6.3 -10dBi:

Part Number
ML-2452-PNA7-01R

RFS4011 US Domain 5 GHz High-Gain Patch Antenna Transmit Power Settings

The following is a transmit power table (US domain) per high-gain patch antenna in the 5 GHz band:

20 MHZ CHANNEL	40 MHZ CHANNEL	LEGACY OFDM RATES (6,9,12,18,24,36,48,54 MBPS)	802.11n HT20 RATES (MCS 0 MCS 15)	802.11n HT40 RATES (MCS 0 MCS 15)
36		6.5	10.5	
38	(36, 40)			9.5
40		6.5	10.5	
42		6.5	10.5	
44		6.5	10.5	
46	(44, 48)			9.5

20 MHZ CHANNEL	40 MHZ CHANNEL	LEGACY OFDM RATES (6,9,12,18,24,36,48,54 MBPS)	802.11n HT20 RATES (MCS 0 MCS 15)	802.11n HT40 RATES (MCS 0 MCS 15)
48		6.5	10.5	
52				
54	(52, 56)			
56				
60				
62	(60, 64)			
64				
100				
102	(100, 104)			
104				
108				
112				
110	(108, 112)			
116				
118	(116, 120)			
120				
124				
126	(124, 128)			
128				
132				
134	(132, 136)			
136				
140				
149		6.5	11.0	
151	(149, 153)			11.0
153		6.5	11.0	
157		7.0	11.0	
159	(157, 161)			11.5
161		7.5	11.5	
165		7.5	11.5	

RFS4011 Canada Regulatory Domain 2.4 GHz Band

RFS4011 Canada Domain 2.4 GHz Facade Antenna Model

The following is the RFS4011 facade antenna model for 2.4 GHz, its peak gain is 2.1dBi:

Part Number
ML-2452-PTA4M3X3-1

RFS4011 Canada Domain 2.4 GHz Facade Antenna Maximum Conducted Transmit Power Settings

The following is a transmit power table (Canadian domain) per facade antenna in the 2.4 GHz band:

20 MHZ CHANNEL	40 MHZ CHANNEL	LEGACY DSSS RATES (1, 2, 5.5, 11 MBPS)	LEGACY OFDM RATES (6,9,12,18,24,36,48,54 MBPS)	802.11n HT20 RATES (MCS 0 MCS 15)	802.11n HT40 RATES (MCS 0 MCS15)
1		18.5	16.0	15.5	
2		18.5	16.0	15.5	
3	(1, 5)	18.5	16.0	15.5	12.5
4	(2, 6)	18.5	16.0	15.5	12.5
5	(3, 7)	18.5	16.0	15.5	12.5
6	(4, 8)	21.0	16.0	16.0	15.5
7	(5, 9)	20.0	16.0	15.5	12.5
8	(6, 10)	20.0	16.0	15.5	12.5
9	(7, 11)	20.0	16.0	15.5	12.5
10		20.0	16.0	15.5	
11		20.0	16.0	15.5	

RFS4011 Canada Domain 2.4 GHz MIMO Patch Antenna Model

The following is the RFS4011 MIMO patch antenna model for 2.4 GHz, its peak gain is 3.5dBi:

Part Number
ML-2452-PTA3M3-036

RFS4011 Canada Domain 2.4 GHz MIMO Patch Antenna Maximum Conducted Transmit Power Settings

The following is a transmit power table (Canadian domain) per MIMO patch antenna in the 2.4 GHz band:

20 MHZ CHANNEL	40 MHZ CHANNEL	LEGACY DSSS RATES (1, 2, 5.5, 11 MBPS)	LEGACY OFDM RATES (6,9,12,18,24,36,48,54 MBPS)	802.11n HT20 RATES (MCS 0 MCS 15)	802.11n HT40 RATES (MCS 0 MCS15)
1		18.5	16.0	14.5	
2		18.5	16.0	14.5	
3	(1, 5)	18.5	16.0	14.5	11.5
4	(2, 6)	18.5	16.0	14.5	11.5
5	(3, 7)	18.5	16.0	14.5	11.5
6	(4, 8)	21.0	16.0	16.0	15.5
7	(5, 9)	19.0	16.0	14.5	11.5
8	(6, 10)	19.0	16.0	14.5	11.5
9	(7, 11)	19.0	16.0	14.5	11.5
10		19.0	16.0	14.5	
11		19.0	16.0	14.5	

RFS4011 Canada Domain 2.4 GHz Dipole Antenna Model

The following is the RFS4011 dipole antenna model for 2.4 GHz, its peak gain is 3.1dBi:

Part Number
ML-2452-HPA5-036

RFS4011 Canada Domain 2.4 GHz Dipole Antenna Maximum Conducted Transmit Power Settings

The following is a transmit power table (Canadian domain) per dipole antenna in the 2.4 GHz band:

20 MHZ CHANNEL	40 MHZ CHANNEL	LEGACY DSSS RATES (1, 2, 5.5, 11 MBPS)	LEGACY OFDM RATES (6,9,12,18,24,36,48,54 MBPS)	802.11n HT20 RATES (MCS 0 MCS 15)	802.11n HT40 RATES (MCS 0 MCS15)
1		19.0	14.0	14.0	
2		19.0	14.0	14.0	
3	(1, 5)	19.0	14.0	14.0	11.0
4	(2, 6)	19.0	14.0	14.0	11.0
5	(3, 7)	19.0	14.0	14.0	11.0
6	(4, 8)	21.5	15.5	15.5	14.0
7	(5, 9)	18.5	13.5	13.5	11.0
8	(6, 10)	18.5	13.5	13.5	11.0
9	(7, 11)	18.5	13.5	13.5	11.0

20 MHZ CHANNEL	40 MHZ CHANNEL	LEGACY DSSS RATES (1, 2, 5.5, 11 MBPS)	LEGACY OFDM RATES (6,9,12,18,24,36,48,54 MBPS)	802.11n HT20 RATES (MCS 0 MCS 15)	802.11n HT40 RATES (MCS 0 MCS15)
10		18.5	13.5	13.5	
11		18.5	13.5	13.5	

RFS4011 Canada Domain 2.4 GHz High-Gain Antenna Model

The following is the RFS4011 high-gain antenna model for 2.4 GHz, its peak gain is 7.5dBi:

Part Number
ML-2452-PNA7-01R

RFS4011 Canada Domain 2.4 GHz High-Gain Antenna Maximum Conducted Transmit Power Settings

The following is a transmit power table (Canadian domain) per high-gain antenna in the 2.4 GHz band:

20 MHZ CHANNEL	40 MHZ CHANNEL	LEGACY DSSS RATES (1, 2, 5.5, 11 MBPS)	LEGACY OFDM RATES (6,9,12,18,24,36,48,54 MBPS)	802.11n HT20 RATES (MCS 0 MCS 15)	802.11n HT40 RATES (MCS0 MCS15)
1		17.0	11.0	11.0	
2		17.0	11.0	11.0	
3	(1, 5)	17.0	11.0	11.0	7.5
4	(2, 6)	17.0	11.0	11.0	7.5
5	(3, 7)	17.0	11.0	11.0	7.5
6	(4, 8)	20.0	15.0	15.0	12.5
7	(5, 9)	17.0	11.0	11.0	8.0
8	(6, 10)	17.0	11.0	11.0	8.0
9	(7, 11)	17.0	11.0	11.0	8.0
10		17.0	11.0	11.0	
11		17.0	11.0	11.0	

RFS4011 Canada Regulatory Domain 5 GHz Band

RFS4011 Canada Domain 5 GHz Facade Antenna Model

The following is the RFS4011 facade antenna model for 5 GHz, its peak gain is 3.95dBi:

Part Number
ML-2452-PTA4M3X3-1

RFS4011 Canada Domain 5 GHz Facade Antenna Maximum Conducted Transmit Power Settings

The following is a transmit power table (Canadian domain) per facade antenna in the 5 GHz band:

20 MHZ CHANNEL	40 MHZ CHANNEL	LEGACY OFDM RATES (6,9,12,18,24,36,48,54 MBPS)	802.11n HT20 RATES (MCS 0 MCS 15)	802.11n HT40 RATES (MCS 0 MCS 15)
36		10.0	10.0	
38	(36, 40)			10.0
40		10.0	10.0	
42		10.0	10.0	
44		10.0	10.0	
46	(44, 48)			10.0
48		10.0	10.0	
52				
54	(52, 56)			
56				
60				
62	(60, 64)			
64				
100				
102	(100, 104)			
104				
108				
112				
110	(108, 112)			
116				
118	(116, 120)			
120				
124				
126	(124, 128)			
128				
132				
134	(132, 136)			
136				

20 MHZ CHANNEL	40 MHZ CHANNEL	LEGACY OFDM RATES (6,9,12,18,24,36,48,54 MBPS)	802.11n HT20 RATES (MCS 0 MCS 15)	802.11n HT40 RATES (MCS 0 MCS 15)
140				
149		12.5	12.5	
151	(149, 153)			12.5
153		12.5	12.5	
157		12.5	12.5	
159	(157, 161)			13.0
161		13.0	13.0	
165		13.0	13.0	

RFS4011 Canada Domain 5 GHz MIMO Patch Antenna Model

The following is the RFS4011 MIMO patch antenna model for 5 GHz, its peak gain is 5dBi:

Part Number
ML-2452-PTA3M3-036

RFS4011 Canada Domain 5 GHz MIMO Patch Antenna Maximum Conducted Transmit Power Settings

The following is a transmit power table (Canadian domain) per MIMO patch antenna in the 5 GHz band:

20 MHZ CHANNEL	40 MHZ CHANNEL	LEGACY OFDM RATES (6,9,12,18,24,36,48,54 MBPS)	802.11n HT20 RATES (MCS 0 MCS 15)	802.11n HT40 RATES (MCS 0 MCS 15)
36		11.0	11.0	
38	(36, 40)			11.0
40		11.0	11.0	
42		11.0	11.0	
44		11.0	11.0	
46	(44,48)			11.0
48		11.0	11.0	
52				
54	(52,56)			
56				
60				
62	(60,64)			
64				
100				

20 MHZ CHANNEL	40 MHZ CHANNEL	LEGACY OFDM RATES (6,9,12,18,24,36,48,54 MBPS)	802.11n HT20 RATES (MCS 0 MCS 15)	802.11n HT40 RATES (MCS 0 MCS 15)
102	(100,104)			
104				
108				
112				
110	(108,112)			
116				
118	(116,120)			
120				
124				
126	(124,128)			
128				
132				
134	(132,136)			
136				
140				
149		13.5	13.5	
151	(149,153)			13.5
153		13.5	13.5	
157		13.5	13.5	
159	(157,161)			14.0
161		14.0	14.0	
165		14.0	14.0	

RFS4011 Canada Domain 5 GHz Dipole Antenna Model

The following is the RFS4011 dipole antenna model for 5 GHz, its peak gain is 4.6dBi:

Part Number
ML-2452-HPA5-036

RFS4011 Canada Domain 5 GHz Dipole Antenna Maximum Conducted Transmit Power Settings

The following is a transmit power table (Canadian domain) per dipole antenna in the 5 GHz band:

20 MHZ CHANNEL	40 MHZ CHANNEL	LEGACY OFDM RATES (6,9,12,18,24,36,48,54 MBPS)	802.11n HT20 RATES (MCS 0 MCS 15)	802.11n HT40 RATES (MCS 0 MCS 15)
36		11.0	11.0	
38	(36, 40)			11.0
40		11.0	11.0	
42		11.0	11.0	
44		11.0	11.0	
46	(44, 48)			11.0
48		11.0	11.0	
52				
54	(52, 56)			
56				
60				
62	(60, 64)			
64				
100				
102	(100, 104)			
104				
108				
112				
110	(108, 112)			
116				
118	(116, 120)			
120				
124				
126	(124, 128)			
128				
132				
134	(132, 136)			
136				
140				
149		13.5	13.5	
151	(149, 153)			13.5
153		13.5	13.5	
157		13.5	13.5	
159	(157, 161)			14.0

20 MHZ CHANNEL	40 MHZ CHANNEL	LEGACY OFDM RATES (6,9,12,18,24,36,48,54 MBPS)	802.11n HT20 RATES (MCS 0 MCS 15)	802.11n HT40 RATES (MCS 0 MCS 15)
161		14.0	14.0	
165		14.0	14.0	

RFS4011 Canada Domain 5 GHz High-Gain Antenna Model

The following is the high-gain antenna model for 5 GHz, its peak gain is from 6.3 - 10dBi:

Part Number
ML-2452-PNA7-01R

RFS4011 Canada Domain 5 GHz High-Gain Antenna Transmit Power Settings

The following is a transmit power table (Canadian domain) per high-gain antenna in the 5 GHz band:

20 MHZ CHANNEL	40 MHZ CHANNEL	LEGACY OFDM RATES (6,9,12,18,24,36,48,54 MBPS)	802.11n HT20 RATES (MCS 0 MCS 15)	802.11n HT40 RATES (MCS 0 MCS 15)
36		10.5	10.5	
38	(36, 40)			9.5
40		10.5	10.5	
42		10.5	10.5	
44		10.5	10.5	
46	(44, 48)			9.5
48		10.5	10.5	
52				
54	(52, 56)			
56				
60				
62	(60, 64)			
64				
100				
102	(100, 104)			
104				
108				
112				
110	(108, 112)			
116				

20 MHZ CHANNEL	40 MHZ CHANNEL	LEGACY OFDM RATES (6,9,12,18,24,36,48,54 MBPS)	802.11n HT20 RATES (MCS 0 MCS 15)	802.11n HT40 RATES (MCS 0 MCS 15)
118	(116, 120)			
120				
124				
126	(124, 128)			
128				
132				
134	(132, 136)			
136				
140				
149		11.0	11.0	
151	(149, 153)			11.0
153		11.0	11.0	
157		11.0	11.0	
159	(157, 161)			11.5
161		11.5	11.5	
165		11.5	11.5	

RFS4011 EU Regulatory Domain 2.4 GHz Band

RFS4011 EU Domain 2.4 GHz Facade Antenna Model

The following is the RFS4011 facade antenna model for 2.4 GHz, the peak gain is 2.1dBi:

Part Number
ML-2452-PTA4M3X3-1

RFS4011 EU Domain 2.4 GHz Facade Antenna Maximum Conducted Transmit Power Settings

The following is a transmit power table (EU domain) per facade antenna in the 2.4 GHz band:

20 MHZ CHANNEL	40 MHZ CHANNEL	LEGACY DSSS RATES (1, 2, 5.5, 11 MBPS)	LEGACY OFDM RATES (6,9,12,18,24,36,48,54 MBPS)	802.11n HT20 RATES (MCS 0 MCS 15)	802.11n HT40 RATES (MCS 0 MCS15)
1		6.5	4.0	4.0	
2		6.0	3.5	3.5	
3	(1, 5)	6.0	3.5	3.5	4.0

20 MHZ CHANNEL	40 MHZ CHANNEL	LEGACY DSSS RATES (1, 2, 5.5, 11 MBPS)	LEGACY OFDM RATES (6,9,12,18,24,36,48,54 MBPS)	802.11n HT20 RATES (MCS 0 MCS 15)	802.11n HT40 RATES (MCS 0 MCS15)
4	(2, 6)	6.0	3.5	3.5	3.5
5	(3, 7)	6.0	3.5	3.5	3.5
6	(4, 8)	6.0	3.5	3.5	3.5
7	(5, 9)	6.0	3.5	3.5	3.5
8	(6, 10)	6.0	3.5	3.5	3.5
9	(7, 11)	6.0	3.5	3.5	3.5
10		6.0	3.5	3.5	3.5
11		6.0	3.5	3.5	3.5
12		6.0	3.5	3.5	
13		6.0	3.5	3.5	
14					

RFS4011 EU Domain 2.4 GHz MIMO Patch Antenna Model

The following is the RFS4011 MIMO patch antenna model for 2.4 GHz, its peak gain is 3.5dBi:

Part Number
ML-2452-PTA3M3-036

RFS4011 EU Domain 2.4 GHz MIMO Patch Antenna Maximum Conducted Transmit Power Settings

The following is a transmit power table (EU domain) per MIMO patch antenna in the 2.4 GHz band:

20 MHZ CHANNEL	40 MHZ CHANNEL	LEGACY DSSS RATES (1, 2, 5.5, 11 MBPS)	LEGACY OFDM RATES (6,9,12,18,24,36,48,54 MBPS)	802.11n HT20 RATES (MCS 0 MCS 15)	802.11n HT40 RATES (MCS 0 MCS15)
1		7.5	5.5	5.5	
2		7.5	5.5	5.5	
3	(1, 5)	7.5	5.5	5.5	6.0
4	(2, 6)	7.5	5.5	5.5	6.0
5	(3, 7)	7.5	5.5	5.5	6.0
6	(4, 8)	7.5	5.5	5.5	6.0
7	(5, 9)	7.5	5.5	5.5	6.0
8	(6, 10)	7.5	5.5	5.5	6.0
9	(7, 11)	7.5	5.5	5.5	6.0

20 MHZ CHANNEL	40 MHZ CHANNEL	LEGACY DSSS RATES (1, 2, 5.5, 11 MBPS)	LEGACY OFDM RATES (6,9,12,18,24,36,48,54 MBPS)	802.11n HT20 RATES (MCS 0 MCS 15)	802.11n HT40 RATES (MCS 0 MCS15)
10		7.5	5.5	5.5	6.0
11		7.5	5.5	5.5	6.0
12		7.5	5.5	5.5	
13		7.5	5.5	5.5	
14					

RFS4011 EU Domain 2.4 GHz Dipole Antenna Model

The following is the RFS4011 dipole antenna model for 2.4 GHz, its peak gain is 3.1dBi:

Part Number
ML-2452-HPA5-036

RFS4011 EU Domain 2.4 GHz Dipole Antenna Maximum Conducted Transmit Power Settings

The following is a transmit power table (EU domain) per dipole antenna in the 2.4 GHz band:

20 MHZ CHANNEL	40 MHZ CHANNEL	LEGACY DSSS RATES (1, 2, 5.5, 11 MBPS)	LEGACY OFDM RATES (6,9,12,18,24,36,48,54 MBPS)	802.11n HT20 RATES (MCS 0 MCS 15)	802.11n HT40 RATES (MCS 0 MCS15)
1		8.5	6.5	6.5	
2		8.5	6.5	6.5	
3	(1, 5)	8.5	6.5	6.5	7.0
4	(2, 6)	8.5	6.5	6.5	7.0
5	(3, 7)	8.5	6.5	6.5	7.0
6	(4, 8)	8.5	6.5	6.5	7.0
7	(5, 9)	8.5	6.5	6.5	7.0
8	(6, 10)	8.5	6.5	6.5	7.0
9	(7, 11)	8.5	6.5	6.5	7.0
10		8.5	6.5	6.5	7.0
11		8.5	6.5	6.5	7.0
12		8.5	6.5	6.5	
13		8.5	6.5	6.5	
14					

RFS4011 EU Domain 2.4 GHz High-Gain Antenna Model

The following is the RFS4011 high-gain antenna model for 2.4 GHz, its peak gain is 7.5dBi:

Part Number
ML-2452-PNA7-01R

RFS4011 EU Domain 2.4 GHz High-Gain Antenna Maximum Conducted Transmit Power Settings

The following is a transmit power table (EU domain) per high-gain antenna in the 2.4 GHz band:

20 MHZ CHANNEL	40 MHZ CHANNEL	LEGACY DSSS RATES (1, 2, 5.5, 11 MBPS)	LEGACY OFDM RATES (6,9,12,18,24,36,48,54 MBPS)	802.11n HT20 RATES (MCS 0 MCS 15)	802.11n HT40 RATES (MCS0 MCS15)
1		3.0	1.0	1.0	
2		3.0	0.5	0.5	
3	(1, 5)	3.0	0.5	0.5	1.0
4	(2, 6)	3.0	0.5	0.5	0.5
5	(3, 7)	3.0	0.5	0.5	0.5
6	(4, 8)	3.0	0.5	0.5	0.5
7	(5, 9)	3.0	0.5	0.5	0.5
8	(6, 10)	3.0	0.5	0.5	0.5
9	(7, 11)	3.0	0.5	0.5	0.5
10		3.0	0.5	0.5	0.5
11		3.0	0.5	0.5	0.5
12		3.0	0.5	0.5	
13		3.0	1.0	0.5	
14					

RFS4011 EU Regulatory Domain 5 GHz Band

RFS4011 EU Domain 5 GHz Facade Antenna Model

The following is the RFS4011 facade antenna model for 5 GHz, its peak gain is 3.95dBi:

Part Number
ML-2452-PTA4M3X3-1

RFS4011 EU Domain 5 GHz Facade Antenna Maximum Conducted Transmit Power Settings

The following is a transmit power table (EU domain) per facade antenna in the 5 GHz band:

20 MHZ CHANNEL	40 MHZ CHANNEL	LEGACY OFDM RATES (6,9,12,18,24,36,48,54 MBPS)	802.11n HT20 RATES (MCS 0 MCS 15)	802.11n HT40 RATES (MCS 0 MCS 15)
36		8.5	8.5	
38	(36, 40)			9.5
40		8.5	8.5	
42		8.5	8.5	
44		8.5	8.5	
46	(44, 48)			10.0
48		9.0	9.0	
52				
54	(52, 56)			
56				
60				
62	(60, 64)			
64				
100				
102	(100, 104)			
104				
108				
112				
110	(108, 112)			
116				
118	(116, 120)			
120				
124				
126	(124, 128)			
128				
132				
134	(132, 136)			
136				
140				
149				
151	(149, 153)			
153				
157				
159	(157, 161)			

20 MHZ CHANNEL	40 MHZ CHANNEL	LEGACY OFDM RATES (6,9,12,18,24,36,48,54 MBPS)	802.11n HT20 RATES (MCS 0 MCS 15)	802.11n HT40 RATES (MCS 0 MCS 15)
161				
165				

RFS4011 EU Domain 5 GHz MIMO Patch Antenna Model

The following is the RFS4011 MIMO patch antenna model for 5 GHz, its peak gain is 5dBi:

Part Number
ML-2452-PTA3M3-036

RFS4011 EU Domain 5 GHz MIMO Patch Antenna Maximum Conducted Transmit Power Settings

The following is a transmit power table (EU domain) per MIMO patch antenna in the 5 GHz band:

20 MHZ CHANNEL	40 MHZ CHANNEL	LEGACY OFDM RATES (6,9,12,18,24,36,48,54 MBPS)	802.11n HT20 RATES (MCS 0 MCS 15)	802.11n HT40 RATES (MCS 0 MCS 15)
36		8.5	8.5	
38	(36, 40)			9.5
40		8.5	8.5	
42		8.5	8.5	
44		8.5	8.5	
46	(44,48)			10.0
48		9.0	9.0	
52				
54	(52,56)			
56				
60				
62	(60,64)			
64				
100				
102	(100,104)			
104				
108				
112				
110	(108,112)			
116				

20 MHZ CHANNEL	40 MHZ CHANNEL	LEGACY OFDM RATES (6,9,12,18,24,36,48,54 MBPS)	802.11n HT20 RATES (MCS 0 MCS 15)	802.11n HT40 RATES (MCS 0 MCS 15)
118	(116,120)			
120				
124				
126	(124,128)			
128				
132				
134	(132,136)			
136				
140				
149				
151	(149,153)			
153				
157				
159	(157,161)			
161				
165				

RFS4011 EU Domain 5 GHz Dipole Model

The following is the RFS4011 dipole antenna model for 5 GHz, its peak gain is 4.6 dBi:

Part Number
ML-2452-HPA5-036

RFS4011 EU Domain 5 GHz Dipole Antenna Maximum Conducted Transmit Power Settings

The following is a transmit power table (EU domain) per dipole antenna in the 5 GHz band:

20 MHZ CHANNEL	40 MHZ CHANNEL	LEGACY OFDM RATES (6,9,12,18,24,36,48,54 MBPS)	802.11n HT20 RATES (MCS 0 MCS 15)	802.11n HT40 RATES (MCS 0 MCS 15)
36		10.0	10.0	
38	(36, 40)			11.0
40		10.0	10.0	
42		10.0	10.0	
44		10.5	10.5	
46	(44, 48)			12.5

20 MHZ CHANNEL	40 MHZ CHANNEL	LEGACY OFDM RATES (6,9,12,18,24,36,48,54 MBPS)	802.11n HT20 RATES (MCS 0 MCS 15)	802.11n HT40 RATES (MCS 0 MCS 15)
48		10.5	10.5	
52				
54	(52, 56)			
56				
60				
62	(60, 64)			
64				
100				
102	(100, 104)			
104				
108				
112				
110	(108, 112)			
116				
118	(116, 120)			
120				
124				
126	(124, 128)			
128				
132				
134	(132, 136)			
136				
140				
149				
151	(149, 153)			
153				
157				
159	(157, 161)			
161				
165				

RFS4011 EU Domain 5 GHz High-Gain Antenna Model

The following is the RFS4011 high-gain antenna model for 5 GHz, its peak gain is 6.3 - 10dBi:

Part Number
ML-2452-PNA7-01R

RFS4011 EU Domain 5 GHz High-Gain Antenna Transmit Power Settings

The following is a transmit power table (EU domain) per high-gain antenna in the 5 GHz band:

20 MHZ CHANNEL	40 MHZ CHANNEL	LEGACY OFDM RATES (6,9,12,18,24,36,48,54 MBPS)	802.11n HT20 RATES (MCS 0 MCS 15)	802.11n HT40 RATES (MCS 0 MCS 15)
36		8.5	8.5	
38	(36, 40)			9.5
40		8.5	8.5	
42		8.5	8.5	
44		8.5	8.5	
46	(44, 48)			10.0
48		9.0	9.0	
52				
54	(52, 56)			
56				
60				
62	(60, 64)			
64				
100				
102	(100, 104)			
104				
108				
112				
110	(108, 112)			
116				
118	(116, 120)			
120				
124				
126	(124, 128)			
128				
132				
134	(132, 136)			
136				
140				

20 MHZ CHANNEL	40 MHZ CHANNEL	LEGACY OFDM RATES (6,9,12,18,24,36,48,54 MBPS)	802.11n HT20 RATES (MCS 0 MCS 15)	802.11n HT40 RATES (MCS 0 MCS 15)
149				
151	(149, 153)			
153				
157				
159	(157, 161)			
161				
165				

RFS4011 Japan Regulatory Domain 2.4 GHz Band

RFS4011 Japan Domain 2.4 GHz Facade Antenna Model

The following is the RFS4011 facade antenna model for 2.4 GHz, the peak gain is 2.1dBi:

Part Number
ML-2452-PTA4M3X3-1

RFS4011 Japan Domain 2.4 GHz Facade Antenna Maximum Conducted Transmit Power Settings

The following is a transmit power table (Japan domain) per facade antenna in the 2.4 GHz band:

20 MHZ CHANNEL	40 MHZ CHANNEL	LEGACY DSSS RATES (1, 2, 5.5, 11 MBPS)	LEGACY OFDM RATES (6,9,12,18,24,36,48,54 MBPS)	802.11n HT20 RATES (MCS 0 MCS 15)	802.11n HT40 RATES (MCS 0 MCS 15)
1		10.5	12.0	12.0	
2		10.5	11.5	11.5	
3	(1, 5)	10.5	11.5	11.5	13.5
4	(2, 6)	10.5	11.5	11.5	13.0
5	(3, 7)	10.5	11.5	11.5	13.0
6	(4, 8)	10.5	11.5	11.5	13.0
7	(5, 9)	10.5	11.5	11.5	13.0
8	(6, 10)	10.5	11.5	11.5	13.0
9	(7, 11)	10.5	11.5	11.5	13.0
10	(8, 10)	10.5	11.5	11.5	13.0
11	(9, 13)	10.5	11.5	11.5	13.0
12		10.5	11.5	11.5	

20 MHZ CHANNEL	40 MHZ CHANNEL	LEGACY DSSS RATES (1, 2, 5.5, 11 MBPS)	LEGACY OFDM RATES (6,9,12,18,24,36,48,54 MBPS)	802.11n HT20 RATES (MCS 0 MCS 15)	802.11n HT40 RATES (MCS 0 MCS15)
13		10.5	12.0	12.0	
14		12.5			

RFS4011 Japan Domain 2.4 GHz MIMO Patch Antenna Model

The following is the RFS4011 MIMO patch antenna model for 2.4 GHz, its peak gain is 3.5dBi:

Part Number
ML-2452-PTA3M3-036

RFS4011 Japan Domain 2.4GHz MIMO Patch Antenna Maximum Conducted Transmit Power Settings

The following is a transmit power table (Japan domain) per MIMO patch antenna in the 2.4 GHz band:

20 MHZ CHANNEL	40 MHZ CHANNEL	LEGACY DSSS RATES (1, 2, 5.5, 11 MBPS)	LEGACY OFDM RATES (6,9,12,18,24,36,48,54 MBPS)	802.11n HT20 RATES (MCS 0 MCS 15)	802.11n HT40 RATES (MCS 0 MCS15)
1		10.5	12.0	12.0	
2		10.5	11.5	11.5	
3	(1, 5)	10.5	11.5	11.5	13.5
4	(2, 6)	10.5	11.5	11.5	13.0
5	(3, 7)	10.5	11.5	11.5	13.0
6	(4, 8)	10.5	11.5	11.5	13.0
7	(5, 9)	10.5	11.5	11.5	13.0
8	(6, 10)	10.5	11.5	11.5	13.0
9	(7, 11)	10.5	11.5	11.5	13.0
10	(8, 10)	10.5	11.5	11.5	13.0
11	(9, 13)	10.5	11.5	11.5	13.0
12		10.5	11.5	11.5	
13		10.5	12.0	12.0	
14		12.5			

RFS4011 Japan Domain 2.4 GHz Dipole Antenna Model

The following is the RFS4011 dipole antenna model for 2.4 GHz, its peak gain is 3.1dBi:

Part Number
ML-2452-HPA5-036

RFS4011 Japan Domain 2.4 GHz Dipole Antenna Maximum Conducted Transmit Power Settings

The following is a transmit power table (Japan domain) per dipole antenna in the 2.4 GHz band:

20 MHZ CHANNEL	40 MHZ CHANNEL	LEGACY DSSS RATES (1, 2, 5.5, 11 MBPS)	LEGACY OFDM RATES (6,9,12,18,24,36,48,54 MBPS)	802.11n HT20 RATES (MCS 0 MCS 15)	802.11n HT40 RATES (MCS 0 MCS15)
1		12.5	14.0	14.0	
2		12.0	13.5	13.5	
3	(1, 5)	12.0	13.5	13.5	15.0
4	(2, 6)	12.0	13.5	13.5	15.0
5	(3, 7)	12.0	13.5	13.5	15.0
6	(4, 8)	12.0	13.5	13.5	15.0
7	(5, 9)	12.0	13.5	13.5	15.0
8	(6, 10)	12.0	13.5	13.5	15.0
9	(7, 11)	12.0	13.5	13.5	15.0
10	(8, 10)	12.0	13.5	13.5	15.0
11	(9, 13)	12.0	13.5	13.5	15.0
12		12.0	13.5	13.5	
13		12.5	14.0	14.0	
14		14.5			

RFS4011 Japan Domain 2.4 GHz High-Gain Antenna Model

The following is the RFS4011 high-gain antenna model for 2.4 GHz, its peak gain is 7.5dBi:

Part Number
ML-2452-PNA7-01R

RFS4011 EJapan Domain 2.4 GHz High-Gain Antenna Maximum Conducted Transmit Power Settings

The following is a transmit power table (Japan domain) per high-gain antenna in the 2.4 GHz band:

20 MHZ CHANNEL	40 MHZ CHANNEL	LEGACY DSSS RATES (1, 2, 5.5, 11 MBPS)	LEGACY OFDM RATES (6,9,12,18,24,36,48,54 MBPS)	802.11n HT20 RATES (MCS 0 MCS 15)	802.11n HT40 RATES (MCS0 MCS15)
1		8.0	9.0	9.0	
2		8.0	9.0	9.0	
3	(1, 5)	8.0	9.0	9.0	14.5
4	(2, 6)	8.0	9.0	9.0	14.0
5	(3, 7)	8.0	9.0	9.0	14.0
6	(4, 8)	8.0	9.0	9.0	14.0
7	(5, 9)	8.0	9.0	9.0	14.0
8	(6, 10)	8.0	9.0	9.0	14.0
9	(7, 11)	8.0	9.0	9.0	14.0
10	(8, 10)	8.0	9.0	9.0	14.0
11	(9, 13)	8.0	9.0	9.0	14.0
12		8.0	9.0	9.0	
13		8.0	9.5	9.5	
14		10.0			

RFS4011 Japan Regulatory Domain 5 GHz Band

RFS4011 Japan Domain 5 GHz Facade Antenna Model

The following is the RFS4011 facade antenna model for 5 GHz, its peak gain is 3.95dBi:

Part Number
ML-2452-PTA4M3X3-1

RFS4011 Japan Domain 5 GHz Facade Antenna Maximum Conducted Transmit Power Settings

The following is a transmit power table (Japan domain) per facade antenna in the 5 GHz band:

20 MHZ CHANNEL	40 MHZ CHANNEL	LEGACY OFDM RATES (6,9,12,18,24,36,48,54 MBPS)	802.11n HT20 RATES (MCS 0 MCS 15)	802.11n HT40 RATES (MCS 0 MCS 15)
36		10.5	11.0	
38	(36, 40)			11.5
40		10.0	10.5	
42		9.5	10.0	
44		9.5	10.0	

20 MHZ CHANNEL	40 MHZ CHANNEL	LEGACY OFDM RATES (6,9,12,18,24,36,48,54 MBPS)	802.11n HT20 RATES (MCS 0 MCS 15)	802.11n HT40 RATES (MCS 0 MCS 15)
46	(44, 48)			11.0
48		9.5	10.0	
52				
54	(52, 56)			
56				
60				
62	(60, 64)			
64				
100				
102	(100, 104)			
104				
108				
112				
110	(108, 112)			
116				
118	(116, 120)			
120				
124				
126	(124, 128)			
128				
132				
134	(132, 136)			
136				
140				
149				
151	(149, 153)			
153				
157				
159	(157, 161)			
161				
165				

RFS4011 Japan Domain 5 GHz MIMO Patch Antenna Model

The following is the RFS4011 MIMO patch antenna model for 5 GHz, its peak gain is 5dBi:

Part Number
ML-2452-PTA3M3-036

RFS4011 Japan Domain 5 GHz MIMO Patch Antenna Maximum Conducted Transmit Power Settings

The following is a transmit power table (Japan domain) per MIMO patch antenna in the 5 GHz band:

20 MHZ CHANNEL	40 MHZ CHANNEL	LEGACY OFDM RATES (6,9,12,18,24,36,48,54 MBPS)	802.11n HT20 RATES (MCS 0 MCS 15)	802.11n HT40 RATES (MCS 0 MCS 15)
36		9.0	9.5	
38	(36, 40)			10.5
40		9.0	9.5	
42		8.5	9.0	
44		8.5	9.0	
46	(44,48)			10.5
48		8.5	9.0	
52				
54	(52,56)			
56				
60				
62	(60,64)			
64				
100				
102	(100,104)			
104				
108				
112				
110	(108,112)			
116				
118	(116,120)			
120				
124				
126	(124,128)			
128				
132				

20 MHZ CHANNEL	40 MHZ CHANNEL	LEGACY OFDM RATES (6,9,12,18,24,36,48,54 MBPS)	802.11n HT20 RATES (MCS 0 MCS 15)	802.11n HT40 RATES (MCS 0 MCS 15)
134	(132,136)			
136				
140				
149				
151	(149,153)			
153				
157				
159	(157,161)			
161				
165				

RFS4011 Japan Domain 5 GHz Dipole Model

The following is the RFS4011 dipole antenna model for 5 GHz, its peak gain is 4.6 dBi:

Part Number
ML-2452-HPA5-036

RFS4011 Japan Domain 5 GHz Dipole Antenna Maximum Conducted Transmit Power Settings

The following is a transmit power table (Japan domain) per dipole antenna in the 5 GHz band:

20 MHZ CHANNEL	40 MHZ CHANNEL	LEGACY OFDM RATES (6,9,12,18,24,36,48,54 MBPS)	802.11n HT20 RATES (MCS 0 MCS 15)	802.11n HT40 RATES (MCS 0 MCS 15)
36		10.0	10.5	
38	(36, 40)			11.0
40		9.5	10.0	
42		9.0	9.5	
44		9.0	9.5	
46	(44, 48)			10.5
48		9.0	9.5	
52				
54	(52, 56)			
56				
60				
62	(60, 64)			

20 MHZ CHANNEL	40 MHZ CHANNEL	LEGACY OFDM RATES (6,9,12,18,24,36,48,54 MBPS)	802.11n HT20 RATES (MCS 0 MCS 15)	802.11n HT40 RATES (MCS 0 MCS 15)
64				
100				
102	(100, 104)			
104				
108				
112				
110	(108, 112)			
116				
118	(116, 120)			
120				
124				
126	(124, 128)			
128				
132				
134	(132, 136)			
136				
140				
149				
151	(149, 153)			
153				
157				
159	(157, 161)			
161				
165				

RFS4011 Japan Domain 5 GHz High-Gain Antenna Model

The following is the RFS4011 high-gain antenna model for 5 GHz, its peak gain is 6.3 - 10dBi:

Part Number
ML-2452-PNA7-01R

RFS4011 Japan Domain 5 GHz High-Gain Antenna Transmit Power Settings

The following is a transmit power table (Japan domain) per high-gain antenna in the 5 GHz band:

20 MHZ CHANNEL	40 MHZ CHANNEL	LEGACY OFDM RATES (6,9,12,18,24,36,48,54 MBPS)	802.11n HT20 RATES (MCS 0 MCS 15)	802.11n HT40 RATES (MCS 0 MCS 15)
36		8.0	8.5	
38	(36, 40)			9.5
40		8.0	8.5	
42		7.5	8.0	
44		7.5	8.0	
46	(44, 48)			9.5
48		7.5	0.0	
52				
54	(52, 56)			
56				
60				
62	(60, 64)			
64				
100				
102	(100, 104)			
104				
108				
112				
110	(108, 112)			
116				
118	(116, 120)			
120				
124				
126	(124, 128)			
128				
132				
134	(132, 136)			
136				
140				
149				
151	(149, 153)			
153				
157				
159	(157, 161)			

20 MHZ CHANNEL	40 MHZ CHANNEL	LEGACY OFDM RATES (6,9,12,18,24,36,48,54 MBPS)	802.11n HT20 RATES (MCS 0 MCS 15)	802.11n HT40 RATES (MCS 0 MCS 15)
161				
165				

13 AP-6511 Regulatory Domains

AP-6511 US Regulatory Domain 2.4 GHz Band
 AP-6511 US Regulatory Domain 5 GHz Band
 AP-6511 EU Regulatory Domain 2.4 GHz Band
 AP-6511 EU Regulatory Domain 5 GHz Band
 AP-6511 Japan Regulatory Domain 2.4 GHz Band
 AP-6511 Japan Regulatory Domain 5 GHz Band

The AP-6511 model Access Point contains two internal (embedded) dual-band antennas supporting both the 802.11bgn (2.4 GHz) and 802.11an (5.0 GHz) bands. No customer assembly or antenna orientation is required.

The AP-6511 radio can transmit on one or two antennas depending on the operating modes. The radio can receive on one or two antennas as well. The data rates supported are different in each case.

- 2.4 GHz Internal Antenna Peak Gain - 2dBi
- 5 GHz Internal Antenna Peak Gain - 4.5dBi

AP-6511 US Regulatory Domain 2.4 GHz Band

The following is a transmit power table (US domain) per antenna in the 2.4 GHz band:

20 MHZ CHANNEL	40 MHZ CHANNEL	LEGACY DSSS RATES (1, 2, 5.5, 11 MBPS)	LEGACY OFDM RATES (6,9,12,18,24,36,48,54 MBPS)	802.11n HT20 RATES (MCS 0 MCS 15)	802.11n HT40 RATES (MCS 0 MCS15)
1		23	17	18	
2		24	18	18	
3	(1, 5)	24	18	18	14
4	(2, 6)	24	18	18	16
5	(3, 7)	24	18	18	17
6	(4, 8)	24	18	18	16
7	(5, 9)	24	18	18	16
8	(6, 10)	24	18	18	17
9	(7, 11)	24	18	18	15
10		24	18	18	
11		23	18	17	

AP-6511 US Regulatory Domain 5 GHz Band

The following is a transmit power table (US domain) per antenna in the 5 GHz band:

20 MHZ CHANNEL	40 MHZ CHANNEL	LEGACY OFDM RATES (6,9,12,18,24,36,48,54 MBPS)	802.11n HT20 RATES (MCS 0 MCS 15)	802.11n HT40 RATES (MCS 0 MCS 15)
36		13	14	
38	(36, 40)	13	14	14
40		13	14	
42		13	14	
44		13	14	
46	(44, 48)	13	14	14
48		13	14	
52		20	20	
54	(52, 56)	20	20	21
56		20	20	
60		20	20	
62	(60, 64)	20	20	13
64		18	16	
100		20	20	
102	(100, 104)	20	20	21
104		20	20	
108		20	20	
112		20	20	
110	(108, 112)	20	20	21
116		20	20	
118	(116, 120)	20	20	21
120		20	20	
124		20	20	
126	(124, 128)	20	20	21
128		20	20	
132		20	20	
134	(132, 136)	20	20	21
136		20	20	
140		20	20	
149		20	20	
151	(149, 153)	20	20	21
153		20	20	

20 MHZ CHANNEL	40 MHZ CHANNEL	LEGACY OFDM RATES (6,9,12,18,24,36,48,54 MBPS)	802.11n HT20 RATES (MCS 0 MCS 15)	802.11n HT40 RATES (MCS 0 MCS 15)
157		20	20	
159	(157, 161)	20	20	21
161		20	20	
165		20	20	

AP-6511 EU Regulatory Domain 2.4 GHz Band

The following is a transmit power table (EU domain) per antenna in the 2.4 GHz band:

20 MHZ CHANNEL	40 MHZ CHANNEL	LEGACY DSSS RATES (1, 2, 5.5, 11 MBPS)	LEGACY OFDM RATES (6,9,12,18,24,36,48,54 MBPS)	802.11n HT20 RATES (MCS 0 MCS 15)	802.11n HT40 RATES (MCS 0 MCS 15)
1		15	15	15	
2		15	15	15	
3	(1, 5)	15	15	15	15
4	(2, 6)	15	15	15	15
5	(3, 7)	15	15	15	15
6	(4, 8)	15	15	15	15
7	(5, 9)	15	15	15	15
8	(6, 10)	15	15	15	15
9	(7, 11)	15	15	15	15
10	(8, 12)	15	15	15	15
11	(9, 13)	15	15	15	15
12		15	15	15	
13		15	15	15	
14					

AP-6511 EU Regulatory Domain 5 GHz Band

The following is a transmit power table (EU domain) per antenna in the 5 GHz band:

20 MHZ CHANNEL	40 MHZ CHANNEL	LEGACY OFDM RATES (6,9,12,18,24,36,48,54 MBPS)	802.11n HT20 RATES (MCS 0 MCS 15)	802.11n HT40 RATES (MCS 0 MCS 15)
36		14	14	
38	(36, 40)	14	14	14

20 MHZ CHANNEL	40 MHZ CHANNEL	LEGACY OFDM RATES (6,9,12,18,24,36,48,54 MBPS)	802.11n HT20 RATES (MCS 0 MCS 15)	802.11n HT40 RATES (MCS 0 MCS 15)
40		14	14	
42		14	14	
44		14	14	
46	(44, 48)	14	14	14
48		14	14	
52		14	14	
54	(52, 56)	14	14	14
56		14	14	
60		14	14	
62	(60, 64)	14	14	14
64		14	14	
100		20	20	
102	(100, 104)	20	20	20
104		20	20	
108		20	20	
112		20	20	
110	(108, 112)	20	20	20
116		20	20	
118	(116, 120)	20	20	20
120		20	20	
124		20	20	
126	(124, 128)	20	20	20
128		20	20	
132		20	20	
134	(132, 136)	20	20	20
136		20	20	
140		20	20	
149		20	20	
151	(149, 153)	20	20	20
153		20	20	
157		20	20	
159	(157, 161)	20	20	20
161		20	20	
165		20	20	

AP-6511 Japan Regulatory Domain 2.4 GHz Band

The following is a transmit power table (Japan domain) per antenna in the 2.4 GHz band:

20 MHZ CHANNEL	40 MHZ CHANNEL	LEGACY DSSS RATES (1, 2, 5.5, 11 MBPS)	LEGACY OFDM RATES (6,9,12,18,24,36,48,54 MBPS)	802.11n HT20 RATES (MCS 0 MCS 15)	802.11n HT40 RATES (MCS 0 MCS15)
1		12	12	14	
2		12	12	14	
3	(1, 5)	12	12	14	11
4	(2, 6)	12	12	14	11
5	(3, 7)	12	12	14	11
6	(4, 8)	12	12	14	11
7	(5, 9)	12	12	14	11
8	(6, 10)	12	12	14	11
9	(7, 11)	12	12	14	11
10	(8, 12)	12	12	14	11
11	(9, 13)	12	12	14	11
12		12	12	14	
13		12	12	14	
14		14			

AP-6511 Japan Regulatory Domain 5 GHz Band

The following is a transmit power table (Japan domain) per antenna in the 5 GHz band:

20 MHZ CHANNEL	40 MHZ CHANNEL	LEGACY OFDM RATES (6,9,12,18,24,36,48,54 MBPS)	802.11n HT20 RATES (MCS 0 MCS 15)	802.11n HT40 RATES (MCS 0 MCS 15)
36		7	9	
38	(36, 40)	7	9	10
40		7	9	
42		7	9	
44		7	9	
46	(44, 48)	7	9	10
48		7	9	
52		7	9	
54	(52, 56)	7	9	10
56		7	9	

20 MHZ CHANNEL	40 MHZ CHANNEL	LEGACY OFDM RATES (6,9,12,18,24,36,48,54 MBPS)	802.11n HT20 RATES (MCS 0 MCS 15)	802.11n HT40 RATES (MCS 0 MCS 15)
60		7	9	
62	(60, 64)	7	9	10
64		7	9	
100		11	12	
102	(100, 104)	11	12	11
104		11	12	
108		11	12	
112		11	12	
110	(108, 112)	11	12	11
116		11	12	
118	(116, 120)	11	12	11
120		11	12	
124		11	12	
126	(124, 128)	11	12	11
128		11	12	
132		11	12	
134	(132, 136)	11	12	11
136		11	12	
140		11	12	
149				
151	(149, 153)			
153				
157				
159	(157, 161)			
161				
165				

14 AP-621 and AP-6521 Regulatory Domains

AP-621 (Standard Power) US Regulatory Domain 2.4GHz Band
 AP-621 (Standard Power) US Regulatory Domain 5GHz Band
 AP-6521 (High Power) US Regulatory Domain 2.4GHz Band
 AP-6521 (High Power) US Regulatory Domain 5GHz Band
 AP-621 (Standard Power) EU Regulatory Domain 2.4GHz Band
 AP-621 (Standard Power) EU Regulatory Domain 5GHz Band
 AP-6521 (High Power) EU Regulatory Domain 2.4GHz Band
 AP-6521 (High Power) EU Regulatory Domain 5GHz Band
 AP-621 (Standard Power) Japan Regulatory Domain 2.4GHz Band
 AP-621 (Standard Power) Japan Regulatory Domain 5GHz Band
 AP-6521 (High Power) Japan Regulatory Domain 2.4GHz Band
 AP-6521 (High Power) Japan Regulatory Domain 5GHz Band

This chapter describes standard and high power transmission capabilities for AP-621 and AP-6521 access points in both the 2.4 and 5GHz radio bands. The information is provided for the US, EU and Japan regulatory domains. AP-621 and AP-6521 access points support 802.11a/b/g/n in both standard and high power SKUs.

AP-621 (Standard Power) US Regulatory Domain 2.4GHz Band

The following are standard power transmit tables (US domain) per listed antenna in the 2.4GHz band:

AP-621 US Domain 2.4 GHz Internal Antenna Model

The following is an AP-621 standard transmit power table (US domain) per Internal antenna in the 2.4GHz band:

20 MHZ CHANNEL	40 MHZ CHANNEL	LEGACY DSSS RATES (1, 2, 5.5, 11 MBPS)	LEGACY OFDM RATES (6,9,12,18,24,36,48, 54 MBPS)	802.11n HT20 RATES (MCS 0 MCS 15)	802.11n HT40 RATES (MCS 0 MCS15)
1		19	14	14	
2		19	15	15	
3	(1, 5)	19	15	15	10
4	(2, 6)	19	15	15	12
5	(3, 7)	19	15	15	14
6	(4, 8)	23	15	15	14

20 MHZ CHANNEL	40 MHZ CHANNEL	LEGACY DSSS RATES (1, 2, 5.5, 11 MBPS)	LEGACY OFDM RATES (6,9,12,18,24,36,48, 54 MBPS)	802.11n HT20 RATES (MCS 0 MCS 15)	802.11n HT40 RATES (MCS 0 MCS15)
7	(5, 9)	21	15	15	14
8	(6, 10)	21	15	15	14
9	(7, 11)	21	15	15	14
10	(8, 12)	21	15	15	
11	(9, 13)	21	15	15	

Internal antenna, peak gain = 3dBi

AP-621 US Domain 2.4 GHz Dipole Antenna Model

The following is an AP-621 standard transmit power table (US domain) per Dipole antenna in the 2.4GHz band:

20 MHZ CHANNEL	40 MHZ CHANNEL	LEGACY DSSS RATES (1, 2, 5.5, 11 MBPS)	LEGACY OFDM RATES (6,9,12,18,24,36,48, 54 MBPS)	802.11n HT20 RATES (MCS 0 MCS 15)	802.11n HT40 RATES (MCS 0 MCS15)
1		18	12	11	
2		18	13	13	
3	(1, 5)	20.5	13	13.5	7.5
4	(2, 6)	20.5	13	13.5	9
5	(3, 7)	20.5	13	13.5	10.5
6	(4, 8)	20.5	13	13.5	12
7	(5, 9)	20.5	13	13.5	10.5
8	(6, 10)	20.5	13	13.5	9
9	(7, 11)	17	13	13.5	6
10	(8, 12)	17	10.5	10.5	
11	(9, 13)	16.5	10.5	10.5	

Dipole antenna, peak gain = 10.5dBi

AP-621 US Domain 2.4 GHz Panel Antenna Model

The following is an AP-621 standard transmit power table (US domain) per Panel antenna in the 2.4GHz band:

20 MHZ CHANNEL	40 MHZ CHANNEL	LEGACY DSSS RATES (1, 2, 5.5, 11 MBPS)	LEGACY OFDM RATES (6,9,12,18,24,36,48, 54 MBPS)	802.11n HT20 RATES (MCS 0 MCS 15)	802.11n HT40 RATES (MCS 0 MCS15)
1		19	12	12	
2		19	12	12	
3	(1, 5)	24	18	18	6
4	(2, 6)	24	18	18	10
5	(3, 7)	24	18	18	13
6	(4, 8)	24	18	18	14
7	(5, 9)	24	18	18	14
8	(6, 10)	24	18	18	14
9	(7, 11)	24	18	18	12
10	(8, 12)	23	14	14	11
11	(9, 13)	22	14	14	6

Panel antenna, peak gain = 4.5dBi

AP-621 US Domain 2.4 GHz Patch Antenna Model

The following is an AP-621 standard transmit power table (US domain) per Patch antenna in the 2.4GHz band:

20 MHZ CHANNEL	40 MHZ CHANNEL	LEGACY DSSS RATES (1, 2, 5.5, 11 MBPS)	LEGACY OFDM RATES (6,9,12,18,24,36,48, 54 MBPS)	802.11n HT20 RATES (MCS 0 MCS 15)	802.11n HT40 RATES (MCS 0 MCS15)
1		18	12.5	11	
2		18	15.5	16	
3	(1, 5)	22.5	16	16	7
4	(2, 6)	22.5	16	16	9
5	(3, 7)	22.5	16	16	10.5
6	(4, 8)	22.5	16	16	9
7	(5, 9)	22.5	16	16	10.5
8	(6, 10)	22.5	16	16	7.5
9	(7, 11)	22.5	16	16	4.5
10	(8, 12)	17	10	9.5	
11	(9, 13)	17	10	9.5	

Patch antenna, peak gain = 7.5dBi

AP-621 (Standard Power) US Regulatory Domain 5GHz Band

The following are standard power transmit tables (US domain) per listed antenna in the 5GHz band:

AP-621 US Domain 5 GHz Internal Dipole Antenna Maximum Conducted Transmit Power Settings

The following is an AP-621 standard transmit power table (US domain) per Internal Dipole antenna in the 5GHz band:

20 MHZ CHANNEL	40 MHZ CHANNEL	LEGACY OFDM RATES (6,9,12,18,24,36,48,54 MBPS)	802.11n HT20 RATES (MCS 0 MCS 15)	802.11n HT40 RATES (MCS 0 MCS 15)
36		12	14	
38	(36, 40)	12	14	14
40		12	14	
42		12	14	
44		12	14	
46	(44, 48)	12	14	14
48		12	14	
52		20	20	
54	(52, 56)	20	20	20
56		20	20	
60		20	20	
62	(60, 64)	20	20	20
64		20	20	
100		15	15	
102	(100, 104)	15	15	11
104		20	20	
108		20	20	
112		20	20	
110	(108, 112)	20	20	20
116		20	20	
118	(116, 120)	20	20	20
120		20	20	
124		20	20	
126	(124, 128)	20	20	20
128		20	20	
132		20	20	
134	(132, 136)	20	14	15

20 MHZ CHANNEL	40 MHZ CHANNEL	LEGACY OFDM RATES (6,9,12,18,24,36,48,54 MBPS)	802.11n HT20 RATES (MCS 0 MCS 15)	802.11n HT40 RATES (MCS 0 MCS 15)
136		20	20	
140		14	14	
149		20	20	
151	(149, 153)	20	20	20
153		20	16	
157		20	20	
159	(157, 161)	20	20	20
161		20	20	
165		20	20	

Internal Dipole antenna with peak gain = 6dBi

AP-621 US Domain 5 GHz External Dipole Antenna Maximum Conducted Transmit Power Settings

The following is an AP-621 standard transmit power table (US domain) per External Dipole antenna in the 5GHz band:

20 MHZ CHANNEL	40 MHZ CHANNEL	LEGACY OFDM RATES (6,9,12,18,24,36,48,54 MBPS)	802.11n HT20 RATES (MCS 0 MCS 15)	802.11n HT40 RATES (MCS 0 MCS 15)
36		11	12	
38	(36, 40)	11	12	12
40		11	12	
42		11	12	
44		11	12	
46	(44, 48)	11	12	12
48		11	12	
52		20	18	
54	(52, 56)	20	20	14
56		20	20	
60		20	20	
62	(60, 64)	20	20	14
64		17	18	
100		12	12	
102	(100, 104)	15	15	9
104		20	20	

20 MHZ CHANNEL	40 MHZ CHANNEL	LEGACY OFDM RATES (6,9,12,18,24,36,48,54 MBPS)	802.11n HT20 RATES (MCS 0 MCS 15)	802.11n HT40 RATES (MCS 0 MCS 15)
108		20	20	
112		20	20	
110	(108, 112)	20	20	19
116		20	20	
118	(116, 120)	20	20	19
120		20	20	
124		20	20	
126	(124, 128)	20	20	20
128		20	20	
132		20	20	
134	(132, 136)	15	15	15
136		20	20	
140		14	13	
149		20	20	
151	(149, 153)	20	20	20
153		20	20	
157		20	20	
159	(157, 161)	20	20	20
161		20	20	
165		20	20	

External Dipole antenna with peak gain = 5dBi

AP-621 US Domain 5 GHz External Panel Antenna Maximum Conducted Transmit Power Settings

The following is an AP-621 standard transmit power table (US domain) per External Panel antenna in the 5GHz band:

20 MHZ CHANNEL	40 MHZ CHANNEL	LEGACY OFDM RATES (6,9,12,18,24,36,48,54 MBPS)	802.11n HT20 RATES (MCS 0 MCS 15)	802.11n HT40 RATES (MCS 0 MCS 15)
36		11	12	
38	(36, 40)	11	12	12
40		11	12	
42		11	12	
44		11	12	

20 MHZ CHANNEL	40 MHZ CHANNEL	LEGACY OFDM RATES (6,9,12,18,24,36,48,54 MBPS)	802.11n HT20 RATES (MCS 0 MCS 15)	802.11n HT40 RATES (MCS 0 MCS 15)
46	(44, 48)	11	12	12
48		11	12	
52		20	16	
54	(52, 56)	20	20	14
56		22	20	
60		20	18	
62	(60, 64)	20	20	13
64		17	19	
100		12	20	
102	(100, 104)	20	20	9
104		20	20	
108		20	20	
112		20	20	
110	(108, 112)	20	11	16
116		17	19	
118	(116, 120)	20	20	20
120		20	20	
124		20	20	
126	(124, 128)	20	20	20
128		20	20	
132		20	20	
134	(132, 136)	20	20	14
136		20	20	
140		15	13	
149		20	20	
151	(149, 153)	20	20	20
153		20	20	
157		20	20	
159	(157, 161)	20	20	20
161		20	20	
165		20	20	

External Panel antenna with peak gain = 5dBi

AP-621 US Domain 5 GHz External Patch Antenna Maximum Conducted Transmit Power Settings

The following is an AP-621 standard transmit power table (US domain) per External Patch antenna in the 5GHz band:

20 MHZ CHANNEL	40 MHZ CHANNEL	LEGACY OFDM RATES (6,9,12,18,24,36,48,54 MBPS)	802.11n HT20 RATES (MCS 0 MCS 15)	802.11n HT40 RATES (MCS 0 MCS 15)
36		11.5	12.5	
38	(36, 40)	11.5	13	12.5
40		11.5	13	
42		11.5	13	
44		11.5	13	
46	(44, 48)	11.5	13	13
48		11.5	13	
52		18.5	19.5	
54	(52, 56)	19	19.5	19.5
56		19	19.5	
60		19	19.5	
62	(60, 64)	19	19.5	13.5
64		19	19.5	
100		16	15.5	
102	(100, 104)	19	19	12
104		19	19	
108		19	19	
112		19	19	
110	(108, 112)	19	19	19
116		19	19	
118	(116, 120)	19	19	19
120		19	19	
124		19	19	
126	(124, 128)	19	19	19
128		19	19	
132		19	19	
134	(132, 136)	19	19	15
136		19	19	
140		16	16	
149		18	18	

20 MHZ CHANNEL	40 MHZ CHANNEL	LEGACY OFDM RATES (6,9,12,18,24,36,48,54 MBPS)	802.11n HT20 RATES (MCS 0 MCS 15)	802.11n HT40 RATES (MCS 0 MCS 15)
151	(149, 153)	18.5	18.5	18.5
153		18.5	18.5	
157		18.5	18.5	
159	(157, 161)	18.5	18.5	18.5
161		18.5	18.5	
165		18.5	18.5	

External Patch antenna with peak gain = 5dBi

AP-6521 (High Power) US Regulatory Domain 2.4GHz Band

The following are high power transmit tables (US domain) per listed antenna in the 2.4GHz band:

AP-6521 US Domain 2.4 GHz Internal Antenna Model

The following is an AP-6521 high transmit power table (US domain) per Internal antenna in the 2.4GHz band:

20 MHZ CHANNEL	40 MHZ CHANNEL	LEGACY DSSS RATES (1, 2, 5.5, 11 MBPS)	LEGACY OFDM RATES (6,9,12,18,24,36,48, 54 MBPS)	802.11n HT20 RATES (MCS 0 MCS 15)	802.11n HT40 RATES (MCS 0 MCS15)
1		19	14	14	
2		19	15	15	
3	(1, 5)	19	15	15	10
4	(2, 6)	19	15	15	12
5	(3, 7)	19	15	15	14
6	(4, 8)	23	15	15	14
7	(5, 9)	21	15	15	14
8	(6, 10)	21	15	15	14
9	(7, 11)	21	15	15	14
10	(8, 12)	21	15	15	
11	(9, 13)	21	15	15	

Internal antenna, peak gain = 3dBi

AP-6521 US Domain 2.4 GHz Dipole Antenna Model

The following is an AP-6521 high transmit power table (US domain) per Dipole antenna in the 2.4GHz band:

20 MHZ CHANNEL	40 MHZ CHANNEL	LEGACY DSSS RATES (1, 2, 5.5, 11 MBPS)	LEGACY OFDM RATES (6,9,12,18,24,36,48, 54 MBPS)	802.11n HT20 RATES (MCS 0 MCS 15)	802.11n HT40 RATES (MCS 0 MCS15)
1		18	12	11	
2		18	13	13	
3	(1, 5)	20.5	13	13.5	7.5
4	(2, 6)	20.5	13	13.5	9
5	(3, 7)	20.5	13	13.5	10.5
6	(4, 8)	20.5	13	13.5	12
7	(5, 9)	20.5	13	13.5	10.5
8	(6, 10)	20.5	13	13.5	9
9	(7, 11)	17	13	13.5	6
10	(8, 12)	17	10.5	10.5	
11	(9, 13)	16.5	10.5	10.5	

Dipole antenna, peak gain = 10.5dBi

AP-6521 US Domain 2.4 GHz Panel Antenna Model

The following is an AP-6521 high transmit power table (US domain) per Panel antenna in the 2.4GHz band:

20 MHZ CHANNEL	40 MHZ CHANNEL	LEGACY DSSS RATES (1, 2, 5.5, 11 MBPS)	LEGACY OFDM RATES (6,9,12,18,24,36,48, 54 MBPS)	802.11n HT20 RATES (MCS 0 MCS 15)	802.11n HT40 RATES (MCS 0 MCS15)
1		19	12	12	
2		19	12	12	
3	(1, 5)	24	18	18	6
4	(2, 6)	24	18	18	10
5	(3, 7)	24	18	18	13
6	(4, 8)	24	18	18	14
7	(5, 9)	24	18	18	14
8	(6, 10)	24	18	18	14
9	(7, 11)	24	18	18	12

20 MHZ CHANNEL	40 MHZ CHANNEL	LEGACY DSSS RATES (1, 2, 5.5, 11 MBPS)	LEGACY OFDM RATES (6,9,12,18,24,36,48, 54 MBPS)	802.11n HT20 RATES (MCS 0 MCS 15)	802.11n HT40 RATES (MCS 0 MCS15)
10	(8, 12)	23	14	14	11
11	(9, 13)	22	14	14	6

Panel antenna, peak gain = 4.5dBi

AP-6521 US Domain 2.4 GHz Patch Antenna Model

The following is an AP-6521 high transmit power table (US domain) per Patch antenna in the 2.4GHz band:

20 MHZ CHANNEL	40 MHZ CHANNEL	LEGACY DSSS RATES (1, 2, 5.5, 11 MBPS)	LEGACY OFDM RATES (6,9,12,18,24,36,48, 54 MBPS)	802.11n HT20 RATES (MCS 0 MCS 15)	802.11n HT40 RATES (MCS 0 MCS15)
1		18	12.5	11	
2		18	15.5	16	
3	(1, 5)	22.5	16	16	7
4	(2, 6)	22.5	16	16	9
5	(3, 7)	22.5	16	16	10.5
6	(4, 8)	22.5	16	16	13
7	(5, 9)	22.5	16	16	10.5
8	(6, 10)	22.5	16	16	7.5
9	(7, 11)	22.5	16	16	4.5
10	(8, 12)	17	10	9.5	
11	(9, 13)	17	10	9.5	

Patch antenna, peak gain = 7.5dBi

AP-6521 (High Power) US Regulatory Domain 5GHz Band

The following are high power transmit tables (US domain) per listed antenna in the 5GHz band:

AP-6521 US Domain 5 GHz Internal Antenna Maximum Conducted Transmit Power Settings

The following is an AP-6521 high transmit power table (US domain) per Internal antenna in the 5GHz band:

20 MHZ CHANNEL	40 MHZ CHANNEL	LEGACY OFDM RATES (6,9,12,18,24,36,48,54 MBPS)	802.11n HT20 RATES (MCS 0 MCS 15)	802.11n HT40 RATES (MCS 0 MCS 15)
36		12	14	
38	(36, 40)	12	14	14
40		12	14	
42		12	14	
44		12	14	
46	(44, 48)	12	14	14
48		12	14	
52		20	20	
54	(52, 56)	20	20	20
56		20	20	
60		20	20	
62	(60, 64)	20	20	20
64		20	20	
100		14	14	
102	(100, 104)	15	15	10
104		20	20	
108		20	20	
112		20	20	
110	(108, 112)	20	20	20
116		20	20	
118	(116, 120)	20	20	20
120		20	20	
124		20	20	
126	(124, 128)	20	20	20
128		20	20	
132		20	20	
134	(132, 136)	20	14	14
136		20	20	
140		20	13	
149		20	20	
151	(149, 153)	20	20	20
153		20	20	
157		20	20	
159	(157, 161)	20	20	20

20 MHZ CHANNEL	40 MHZ CHANNEL	LEGACY OFDM RATES (6,9,12,18,24,36,48,54 MBPS)	802.11n HT20 RATES (MCS 0 MCS 15)	802.11n HT40 RATES (MCS 0 MCS 15)
161		20	20	
165		20	20	

Internal antenna with peak gain = 6dBi

AP-6521 US Domain 5 GHz External Dipole Antenna Maximum Conducted Transmit Power Settings

The following is an AP-6521 high transmit power table (US domain) per External Dipole antenna in the 5GHz band:

20 MHZ CHANNEL	40 MHZ CHANNEL	LEGACY OFDM RATES (6,9,12,18,24,36,48,54 MBPS)	802.11n HT20 RATES (MCS 0 MCS 15)	802.11n HT40 RATES (MCS 0 MCS 15)
36		11	12	
38	(36, 40)	11	12	12
40		11	12	
42		11	12	
44		11	12	
46	(44, 48)	11	12	12
48		11	12	
52		20	18	
54	(52, 56)	20	20	14
56		20	20	
60		20	20	
62	(60, 64)	20	20	14
64		17	18	
100		12	12	
102	(100, 104)	15	15	9
104		21	20	
108		21	20	
112		21	20	
110	(108, 112)	21	20	19
116		21	20	
118	(116, 120)	21	20	20
120		21	20	
124		21	20	

20 MHZ CHANNEL	40 MHZ CHANNEL	LEGACY OFDM RATES (6,9,12,18,24,36,48,54 MBPS)	802.11n HT20 RATES (MCS 0 MCS 15)	802.11n HT40 RATES (MCS 0 MCS 15)
126	(124, 128)	21	20	20
128		21	20	
132		21	20	
134	(132, 136)	15	15	15
136		20	20	
140		13	13	
149		20	20	
151	(149, 153)	20	20	20
153		20	20	
157		20	20	
159	(157, 161)	20	20	20
161		20	20	
165		20	20	

External Dipole antenna with peak gain = 5dBi

AP-6521 US Domain 5 GHz External Panel Antenna Maximum Conducted Transmit Power Settings

The following is an AP-6521 high transmit power table (US domain) per External Panel antenna in the 5GHz band:

20 MHZ CHANNEL	40 MHZ CHANNEL	LEGACY OFDM RATES (6,9,12,18,24,36,48,54 MBPS)	802.11n HT20 RATES (MCS 0 MCS 15)	802.11n HT40 RATES (MCS 0 MCS 15)
36		11	12	
38	(36, 40)	11	12	12
40		11	12	
42		11	12	
44		11	12	
46	(44, 48)	11	12	12
48		11	12	
52		20	16	
54	(52, 56)	20	20	14
56		20	20	
60		20	18	
62	(60, 64)	20	20	13

20 MHZ CHANNEL	40 MHZ CHANNEL	LEGACY OFDM RATES (6,9,12,18,24,36,48,54 MBPS)	802.11n HT20 RATES (MCS 0 MCS 15)	802.11n HT40 RATES (MCS 0 MCS 15)
64		17	19	
100		12	11	
102	(100, 104)	20	20	9
104		20	20	
108		20	20	
112		20	20	
110	(108, 112)	20	11	16
116		20	19	
118	(116, 120)	20	20	20
120		20	20	
124		20	20	
126	(124, 128)	20	20	20
128		20	20	
132		20	20	
134	(132, 136)	20	20	14
136		20	20	
140		14	13	
149		20	20	
151	(149, 153)	20	20	20
153		20	20	
157		20	20	
159	(157, 161)	20	20	20
161		20	20	
165		20	20	

External Panel antenna with peak gain = 5dBi

AP-6521 US Domain 5 GHz External Patch Antenna Maximum Conducted Transmit Power Settings

The following is an AP-6521 high transmit power table (US domain) per External Patch antenna in the 5GHz band:

20 MHZ CHANNEL	40 MHZ CHANNEL	LEGACY OFDM RATES (6,9,12,18,24,36,48,54 MBPS)	802.11n HT20 RATES (MCS 0 MCS 15)	802.11n HT40 RATES (MCS 0 MCS 15)
36		11.5	12.5	
38	(36, 40)	11.5	13	12.5
40		11.5	13	
42		11.5	13	
44		11.5	13	
46	(44, 48)	11.5	13	13
48		11.5	13	
52		18.5	19.5	
54	(52, 56)	19	19.5	19.5
56		19	19.5	
60		19	19.5	
62	(60, 64)	19	19.5	13.5
64		19	19.5	
100		16	15.5	
102	(100, 104)	19	19	12
104		19	19	
108		19	19	
112		19	19	
110	(108, 112)	19	19	19
116		19	19	
118	(116, 120)	19	19	19
120		19	19	
124		19	19	
126	(124, 128)	19	19	19
128		19	19	
132		19	19	
134	(132, 136)	19	19	15
136		19	19	
140		16	16	
149		18	18	
151	(149, 153)	18.5	18.5	18.5
153		18.5	18.5	
157		18.5	18.5	
159	(157, 161)	18.5	18.5	18.5

20 MHZ CHANNEL	40 MHZ CHANNEL	LEGACY OFDM RATES (6,9,12,18,24,36,48,54 MBPS)	802.11n HT20 RATES (MCS 0 MCS 15)	802.11n HT40 RATES (MCS 0 MCS 15)
161		18.5	18.5	
165		18.5	18.5	

External Patch antenna with peak gain = 5dBi

AP-621 (Standard Power) EU Regulatory Domain 2.4GHz Band

The following are standard power transmit tables (EU domain) per listed antenna in the 2.4GHz band:

AP-621 EU Domain 2.4 GHz Internal Antenna Model

The following is an AP-621 standard transmit power table (EU domain) per Internal antenna in the 2.4GHz band:

20 MHZ CHANNEL	40 MHZ CHANNEL	LEGACY DSSS RATES (1, 2, 5.5, 11 MBPS)	LEGACY OFDM RATES (6,9,12,18,24,36,48, 54 MBPS)	802.11n HT20 RATES (MCS 0 MCS 15)	802.11n HT40 RATES (MCS 0 MCS15)
1		14	14	14	
2		14	14	14	
3	(1, 5)	14	14	14	14
4	(2, 6)	14	14	14	14
5	(3, 7)	14	14	14	14
6	(4, 8)	14	14	14	14
7	(5, 9)	14	14	14	14
8	(6, 10)	14	14	14	14
9	(7, 11)	14	14	14	14
10	(8, 12)	14	14	14	14
11	(9, 13)	14	14	14	14
12		14	14	14	
13		14	14	14	
14					

Internal antenna, peak gain = 3dBi

AP-621 EU Domain 2.4 GHz Dipole Antenna Model

The following is an AP-621 standard transmit power table (EU domain) per Dipole antenna in the 2.4GHz band:

20 MHZ CHANNEL	40 MHZ CHANNEL	LEGACY DSSS RATES (1, 2, 5.5, 11 MBPS)	LEGACY OFDM RATES (6,9,12,18,24,36,48, 54 MBPS)	802.11n HT20 RATES (MCS 0 MCS 15)	802.11n HT40 RATES (MCS 0 MCS15)
1		12	12	12	
2		12	12	12	
3	(1, 5)	12	12	12	12
4	(2, 6)	12	12	12	12
5	(3, 7)	12	12	12	12
6	(4, 8)	12	12	12	12
7	(5, 9)	12	12	12	12
8	(6, 10)	12	12	12	12
9	(7, 11)	12	12	12	12
10	(8, 12)	12	12	12	12
11	(9, 13)	12	12	12	12
12		12	12	12	
13		12	12	12	
14					

Dipole antenna, peak gain = 4.6dBi

AP-621 EU Domain 2.4 GHz Panel Antenna Model

The following is an AP-621 standard transmit power table (EU domain) per Panel antenna in the 2.4GHz band:

20 MHZ CHANNEL	40 MHZ CHANNEL	LEGACY DSSS RATES (1, 2, 5.5, 11 MBPS)	LEGACY OFDM RATES (6,9,12,18,24,36,48, 54 MBPS)	802.11n HT20 RATES (MCS 0 MCS 15)	802.11n HT40 RATES (MCS 0 MCS15)
1		12	12	12	
2		12	12	12	
3	(1, 5)	12	12	12	12
4	(2, 6)	12	12	12	12
5	(3, 7)	12	12	12	12
6	(4, 8)	12	12	12	12
7	(5, 9)	12	12	12	12
8	(6, 10)	12	12	12	12
9	(7, 11)	12	12	12	12
10	(8, 12)	12	12	12	12

20 MHZ CHANNEL	40 MHZ CHANNEL	LEGACY DSSS RATES (1, 2, 5.5, 11 MBPS)	LEGACY OFDM RATES (6,9,12,18,24,36,48, 54 MBPS)	802.11n HT20 RATES (MCS 0 MCS 15)	802.11n HT40 RATES (MCS 0 MCS15)
11	(9, 13)	12	12	12	12
12		12	12	12	
13		12	12	12	
14					

Panel antenna, peak gain = 4.5dBi

AP-621 EU Domain 2.4 GHz Patch Antenna Model

The following is an AP-621 standard transmit power table (EU domain) per Patch antenna in the 2.4GHz band:

20 MHZ CHANNEL	40 MHZ CHANNEL	LEGACY DSSS RATES (1, 2, 5.5, 11 MBPS)	LEGACY OFDM RATES (6,9,12,18,24,36,48, 54 MBPS)	802.11n HT20 RATES (MCS 0 MCS 15)	802.11n HT40 RATES (MCS 0 MCS15)
1		14	14	14	
2		14	14	14	
3	(1, 5)	14	14	14	14
4	(2, 6)	14	14	14	14
5	(3, 7)	14	14	14	14
6	(4, 8)	14	14	14	14
7	(5, 9)	14	14	14	14
8	(6, 10)	14	14	14	14
9	(7, 11)	14	14	14	14
10	(8, 12)	14	14	14	14
11	(9, 13)	14	14	14	14
12		14	14	14	
13		14	14	14	
14					

Patch antenna, peak gain = 3dBi

AP-621 (Standard Power) EU Regulatory Domain 5GHz Band

The following are standard power transmit tables (EU domain) per listed antenna in the 5GHz band:

AP-621 EU Domain 5 GHz External Dipole Antenna Maximum Conducted Transmit Power Settings

The following is an AP-621 standard transmit power table (EU domain) per External Dipole antenna in the 5GHz band:

20 MHZ CHANNEL	40 MHZ CHANNEL	LEGACY OFDM RATES (6,9,12,18,24,36,48,54 MBPS)	802.11n HT20 RATES (MCS 0 MCS 15)	802.11n HT40 RATES (MCS 0 MCS 15)
36		15	15	
38	(36, 40)	15	15	15
40		15	15	
42		15	15	
44		15	15	
46	(44, 48)	15	15	15
48		15	15	
52		15	15	
54	(52, 56)	15	15	15
56		15	15	
60		15	15	
62	(60, 64)	15	15	15
64		15	15	
100		20	20	
102	(100, 104)	20	20	20
104		20	20	
108		20	20	
112		20	20	
110	(108, 112)	20	20	20
116		20	20	
118	(116, 120)	20	20	20
120		20	20	
124		20	20	
126	(124, 128)	20	20	20
128		20	20	
132		20	20	
134	(132, 136)	20	20	20
136		20	20	
140		20	20	
149				

20 MHZ CHANNEL	40 MHZ CHANNEL	LEGACY OFDM RATES (6,9,12,18,24,36,48,54 MBPS)	802.11n HT20 RATES (MCS 0 MCS 15)	802.11n HT40 RATES (MCS 0 MCS 15)
151	(149, 153)			
153				
157				
159	(157, 161)			
161				
165				

External Dipole antenna with peak gain = 5dBi

AP-621 EU Domain 5 GHz External Panel Antenna Maximum Conducted Transmit Power Settings

The following is an AP-621 standard transmit power table (EU domain) per External Panel antenna in the 5GHz band:

20 MHZ CHANNEL	40 MHZ CHANNEL	LEGACY OFDM RATES (6,9,12,18,24,36,48,54 MBPS)	802.11n HT20 RATES (MCS 0 MCS 15)	802.11n HT40 RATES (MCS 0 MCS 15)
36		14	14	
38	(36, 40)	14	14	15
40		14	14	
42		14	14	
44		14	14	
46	(44, 48)	14	14	15
48		14	14	
52		14	14	
54	(52, 56)	14	14	15
56		14	14	
60		14	14	
62	(60, 64)	14	14	15
64		14	14	
100		20	20	
102	(100, 104)	20	20	20
104		20	20	
108		20	20	
112		20	20	
110	(108, 112)	20	20	20

20 MHZ CHANNEL	40 MHZ CHANNEL	LEGACY OFDM RATES (6,9,12,18,24,36,48,54 MBPS)	802.11n HT20 RATES (MCS 0 MCS 15)	802.11n HT40 RATES (MCS 0 MCS 15)
116		20	20	
118	(116, 120)	20	20	20
120		20	20	
124		20	20	
126	(124, 128)	20	20	20
128		20	20	
132		20	20	
134	(132, 136)	20	20	20
136		20	20	
140		20	20	
149				
151	(149, 153)			
153				
157				
159	(157, 161)			
161				
165				

External Panel antenna with peak gain = 5dBi

AP-621 EU Domain 5 GHz External Patch Antenna Maximum Conducted Transmit Power Settings

The following is an AP-621 standard transmit power table (EU domain) per External Patch antenna in the 5GHz band:

20 MHZ CHANNEL	40 MHZ CHANNEL	LEGACY OFDM RATES (6,9,12,18,24,36,48,54 MBPS)	802.11n HT20 RATES (MCS 0 MCS 15)	802.11n HT40 RATES (MCS 0 MCS 15)
36		16	16	
38	(36, 40)	16	16	16
40		16	16	
42		16	16	
44		16	16	
46	(44, 48)	16	16	16
48		16	16	
52		16	16	

20 MHZ CHANNEL	40 MHZ CHANNEL	LEGACY OFDM RATES (6,9,12,18,24,36,48,54 MBPS)	802.11n HT20 RATES (MCS 0 MCS 15)	802.11n HT40 RATES (MCS 0 MCS 15)
54	(52, 56)	16	16	16
56		16	16	
60		16	16	
62	(60, 64)	16	16	16
64		16	16	
100		20	20	
102	(100, 104)	20	20	20
104		20	20	
108		20	20	
112		20	20	
110	(108, 112)	20	20	20
116		20	20	
118	(116, 120)	20	20	20
120		20	20	
124		20	20	
126	(124, 128)	20	20	20
128		20	20	
132		20	20	
134	(132, 136)	20	20	20
136		20	20	
140		20	20	
149				
151	(149, 153)			
153				
157				
159	(157, 161)			
161				
165				

External Patch antenna with peak gain = 4dBi

AP-621 EU Domain 5 GHz Internal Patch Antenna Maximum Conducted Transmit Power Settings

The following is an AP-621 standard transmit power table (EU domain) per Internal Patch antenna in the 5GHz band:

20 MHZ CHANNEL	40 MHZ CHANNEL	LEGACY OFDM RATES (6,9,12,18,24,36,48,54 MBPS)	802.11n HT20 RATES (MCS 0 MCS 15)	802.11n HT40 RATES (MCS 0 MCS 15)
36		12	12	
38	(36, 40)	13	13	16
40		13	13	
42		13	13	
44		13	13	
46	(44, 48)	13	13	16
48		13	13	
52		13	16	
54	(52, 56)	13	16	16
56		13	16	
60		13	16	
62	(60, 64)	13	16	16
64		13	16	
100		19	20	
102	(100, 104)	19	20	19
104		19	20	
108		19	20	
112		19	20	
110	(108, 112)	19	20	20
116		19	20	
118	(116, 120)	19	20	20
120		19	20	
124		19	20	
126	(124, 128)	19	20	
128		19	20	20
132		19	20	
134	(132, 136)	19	20	20
136		19	20	
140		19	20	
149				
151	(149, 153)			
153				
157				

20 MHZ CHANNEL	40 MHZ CHANNEL	LEGACY OFDM RATES (6,9,12,18,24,36,48,54 MBPS)	802.11n HT20 RATES (MCS 0 MCS 15)	802.11n HT40 RATES (MCS 0 MCS 15)
159	(157, 161)			
161				

Internal Patch antenna with peak gain = 6dBi

AP-6521 (High Power) EU Regulatory Domain 2.4GHz Band

The following are high power transmit tables (EU domain) per listed antenna in the 2.4GHz band:

AP-6521 EU Domain 2.4 GHz Internal Antenna Model

The following is an AP-6521 high transmit power table (EU domain) per Internal antenna in the 2.4GHz band:

20 MHZ CHANNEL	40 MHZ CHANNEL	LEGACY DSSS RATES (1, 2, 5.5, 11 MBPS)	LEGACY OFDM RATES (6,9,12,18,24,36,48, 54 MBPS)	802.11n HT20 RATES (MCS 0 MCS 15)	802.11n HT40 RATES (MCS 0 MCS15)
1		14	14	14	
2		14	14	14	
3	(1, 5)	14	14	14	14
4	(2, 6)	14	14	14	14
5	(3, 7)	14	14	14	14
6	(4, 8)	14	14	14	14
7	(5, 9)	14	14	14	14
8	(6, 10)	14	14	14	14
9	(7, 11)	14	14	14	14
10	(8, 12)	14	14	14	14
11	(9, 13)	14	14	14	14
12		14	14	14	
13		14	14	14	
14					

Internal antenna, peak gain = 3dBi

AP-6521 EU Domain 2.4 GHz Dipole Antenna Model

The following is an AP-6521 high transmit power table (EU domain) per Dipole antenna in the 2.4GHz band:

20 MHZ CHANNEL	40 MHZ CHANNEL	LEGACY DSSS RATES (1, 2, 5.5, 11 MBPS)	LEGACY OFDM RATES (6,9,12,18,24,36,48, 54 MBPS)	802.11n HT20 RATES (MCS 0 MCS 15)	802.11n HT40 RATES (MCS 0 MCS15)
1		12	12	12	
2		12	12	12	
3	(1, 5)	12	12	12	12
4	(2, 6)	12	12	12	12
5	(3, 7)	12	12	12	12
6	(4, 8)	12	12	12	12
7	(5, 9)	12	12	12	12
8	(6, 10)	12	12	12	12
9	(7, 11)	12	12	12	12
10	(8, 12)	12	12	12	12
11	(9, 13)	12	12	12	12
12		12	12	12	
13		12	12	12	
14					

Dipole antenna, peak gain = 4.6dBi

AP-6521 EU Domain 2.4 GHz Panel Antenna Model

The following is an AP-6521 high transmit power table (EU domain) per Panel antenna in the 2.4GHz band:

20 MHZ CHANNEL	40 MHZ CHANNEL	LEGACY DSSS RATES (1, 2, 5.5, 11 MBPS)	LEGACY OFDM RATES (6,9,12,18,24,36,48, 54 MBPS)	802.11n HT20 RATES (MCS 0 MCS 15)	802.11n HT40 RATES (MCS 0 MCS15)
1		12	12	12	
2		12	12	12	
3	(1, 5)	12	12	12	12
4	(2, 6)	12	12	12	12
5	(3, 7)	12	12	12	12
6	(4, 8)	12	12	12	12
7	(5, 9)	12	12	12	12
8	(6, 10)	12	12	12	12
9	(7, 11)	12	12	12	12
10	(8, 12)	12	12	12	12

20 MHZ CHANNEL	40 MHZ CHANNEL	LEGACY DSSS RATES (1, 2, 5.5, 11 MBPS)	LEGACY OFDM RATES (6,9,12,18,24,36,48, 54 MBPS)	802.11n HT20 RATES (MCS 0 MCS 15)	802.11n HT40 RATES (MCS 0 MCS15)
11	(9, 13)	12	12	12	12
12		12	12	12	
13		12	12	12	
14					

Panel antenna, peak gain = 4.5dBi

AP-6521 EU Domain 2.4 GHz Patch Antenna Model

The following is an AP-6521 high transmit power table (EU domain) per Patch antenna in the 2.4GHz band:

20 MHZ CHANNEL	40 MHZ CHANNEL	LEGACY DSSS RATES (1, 2, 5.5, 11 MBPS)	LEGACY OFDM RATES (6,9,12,18,24,36,48, 54 MBPS)	802.11n HT20 RATES (MCS 0 MCS 15)	802.11n HT40 RATES (MCS 0 MCS15)
1		14	14	14	
2		14	14	14	
3	(1, 5)	14	14	14	14
4	(2, 6)	14	14	14	14
5	(3, 7)	14	14	14	14
6	(4, 8)	14	14	14	14
7	(5, 9)	14	14	14	14
8	(6, 10)	14	14	14	14
9	(7, 11)	14	14	14	14
10	(8, 12)	14	14	14	14
11	(9, 13)	14	14	14	14
12		14	14	14	
13		14	14	14	
14					

Patch antenna, peak gain = 3dBi

AP-6521 (High Power) EU Regulatory Domain 5GHz Band

The following are high power transmit tables (EU domain) per listed antenna in the 5GHz band:

AP-6521 EU Domain 5 GHz Internal Antenna Maximum Conducted Transmit Power Settings

The following is an AP-6521 high transmit power table (EU domain) per Internal antenna in the 5GHz band:

20 MHZ CHANNEL	40 MHZ CHANNEL	LEGACY OFDM RATES (6,9,12,18,24,36,48,54 MBPS)	802.11n HT20 RATES (MCS 0 MCS 15)	802.11n HT40 RATES (MCS 0 MCS 15)
36		15	14	
38	(36, 40)	15	14	14
40		15	14	
42		15	14	
44		15	14	
46	(44, 48)	15	14	14
48		15	14	
52		15	14	
54	(52, 56)	15	14	14
56		15	14	
60		15	14	
62	(60, 64)	15	14	14
64		15	14	
100		22	22	
102	(100, 104)	22	22	22
104		22	22	
108		22	22	
112		22	22	
110	(108, 112)	22	22	22
116		22	22	
118	(116, 120)	22	22	22
120		22	22	
124		22	22	
126	(124, 128)	22	22	22
128		22	22	
132		22	22	
134	(132, 136)	22	22	22
136		20	20	
140		20	20	
149				

20 MHZ CHANNEL	40 MHZ CHANNEL	LEGACY OFDM RATES (6,9,12,18,24,36,48,54 MBPS)	802.11n HT20 RATES (MCS 0 MCS 15)	802.11n HT40 RATES (MCS 0 MCS 15)
151	(149, 153)			
153				
157				
159	(157, 161)			
161				
165				

Internal antenna with peak gain = 6dBi

AP-6521 EU Domain 5 GHz External Dipole Antenna Maximum Conducted Transmit Power Settings

The following is an AP-6521 high transmit power table (EU domain) per External Dipole antenna in the 5GHz band:

20 MHZ CHANNEL	40 MHZ CHANNEL	LEGACY OFDM RATES (6,9,12,18,24,36,48,54 MBPS)	802.11n HT20 RATES (MCS 0 MCS 15)	802.11n HT40 RATES (MCS 0 MCS 15)
36		15	15	
38	(36, 40)	15	15	15
40		15	15	
42		15	15	
44		15	15	
46	(44, 48)	15	15	15
48		15	15	
52		15	15	
54	(52, 56)	15	15	15
56		15	15	
60		15	15	
62	(60, 64)	15	15	15
64		15	15	
100		22	22	
102	(100, 104)	22	22	22
104		22	22	
108		22	22	
112		22	22	
110	(108, 112)	22	22	22

20 MHZ CHANNEL	40 MHZ CHANNEL	LEGACY OFDM RATES (6,9,12,18,24,36,48,54 MBPS)	802.11n HT20 RATES (MCS 0 MCS 15)	802.11n HT40 RATES (MCS 0 MCS 15)
116		22	22	
118	(116, 120)	22	22	22
120		22	22	
124		22	22	
126	(124, 128)	22	22	22
128		22	22	
132		22	22	
134	(132, 136)	22	22	22
136		22	22	
140		22	22	
149				
151	(149, 153)			
153				
157				
159	(157, 161)			
161				
165				

External Dipole antenna with peak gain = 5dBi

AP-6521 EU Domain 5 GHz External Panel Antenna Maximum Conducted Transmit Power Settings

The following is an AP-6521 high transmit power table (EU domain) per External Panel antenna in the 5GHz band:

20 MHZ CHANNEL	40 MHZ CHANNEL	LEGACY OFDM RATES (6,9,12,18,24,36,48,54 MBPS)	802.11n HT20 RATES (MCS 0 MCS 15)	802.11n HT40 RATES (MCS 0 MCS 15)
36		15	15	
38	(36, 40)	15	15	15
40		15	15	
42		15	15	
44		15	15	
46	(44, 48)	15	15	15
48		15	15	
52		22	22	

20 MHZ CHANNEL	40 MHZ CHANNEL	LEGACY OFDM RATES (6,9,12,18,24,36,48,54 MBPS)	802.11n HT20 RATES (MCS 0 MCS 15)	802.11n HT40 RATES (MCS 0 MCS 15)
54	(52, 56)	22	22	22
56		22	22	
60		22	22	
62	(60, 64)	22	22	22
64		22	22	
100		22	22	
102	(100, 104)	22	22	22
104		22	22	
108		22	22	
112		22	22	
110	(108, 112)	22	22	22
116		22	22	
118	(116, 120)	22	22	22
120		22	22	
124		22	22	
126	(124, 128)	22	22	22
128		22	22	
132		22	22	
134	(132, 136)	22	22	22
136		22	22	
140		22	22	
149				
151	(149, 153)			
153				
157				
159	(157, 161)			
161				
165				

External Panel antenna with peak gain = 5dBi

AP-6521 EU Domain 5 GHz External Patch Antenna Maximum Conducted Transmit Power Settings

The following is an AP-6521 high transmit power table (EU domain) per External Patch antenna in the 5GHz band:

20 MHZ CHANNEL	40 MHZ CHANNEL	LEGACY OFDM RATES (6,9,12,18,24,36,48,54 MBPS)	802.11n HT20 RATES (MCS 0 MCS 15)	802.11n HT40 RATES (MCS 0 MCS 15)
36		16	16	
38	(36, 40)	16	16	16
40		16	16	
42		16	16	
44		16	16	
46	(44, 48)	16	16	16
48		16	16	
52		16	16	
54	(52, 56)	16	16	16
56		16	16	
60		16	16	
62	(60, 64)	16	16	16
64		16	16	
100		22	22	
102	(100, 104)	22	22	22
104		22	22	
108		22	22	
112		22	22	
110	(108, 112)	22	22	22
116		22	22	
118	(116, 120)	22	22	22
120		22	22	
124		22	22	
126	(124, 128)	22	22	22
128		22	22	
132		22	22	
134	(132, 136)	22	22	22
136		22	22	
140		22	22	
149				
151	(149, 153)			
153				
157				
159	(157, 161)			

20 MHZ CHANNEL	40 MHZ CHANNEL	LEGACY OFDM RATES (6,9,12,18,24,36,48,54 MBPS)	802.11n HT20 RATES (MCS 0 MCS 15)	802.11n HT40 RATES (MCS 0 MCS 15)
161				
165				

External Patch antenna with peak gain = 4dBi

AP-621 (Standard Power) Japan Regulatory Domain 2.4GHz Band

The following are standard power transmit tables (Japan domain) per listed antenna in the 2.4GHz band:

AP-621 Japan Domain 2.4 GHz Dipole (Dual-Band) or Outdoor Omni Dipole Antenna Model

The following is an AP-621 standard transmit power table (Japan domain) per dipole (dual-band) or outdoor omni dipole antenna in the 2.4GHz band:

20 MHZ CHANNEL	40 MHZ CHANNEL	LEGACY DSSS RATES (1, 2, 5.5, 11 MBPS)	LEGACY OFDM RATES (6,9,12,18,24,36,48, 54 MBPS)	802.11n HT20 RATES (MCS 0 MCS 15)	802.11n HT40 RATES (MCS 0 MCS15)
1		17	19	19	
2		17	19	19	
3	(1, 5)	17	19	19	22
4	(2, 6)	17	19	19	22
5	(3, 7)	17	19	19	22
6	(4, 8)	17	19	19	22
7	(5, 9)	17	19	19	22
8	(6, 10)	17	19	19	22
9	(7, 11)	17	19	19	22
10	(8, 12)	17	19	19	22
11	(9, 13)	17	19	19	22
12		17	19	19	
13		17	19	19	
14					

Dipole (dual-band) or outdoor omni dipole antenna with peak gain = 3dBi

AP-621 Japan Domain 2.4 GHz Internal (Dual-Band) Antenna Model

The following is an AP-621 standard transmit power table (Japan domain) per internal (dual-band) antenna in the 2.4GHz band:

20 MHZ CHANNEL	40 MHZ CHANNEL	LEGACY DSSS RATES (1, 2, 5.5, 11 MBPS)	LEGACY OFDM RATES (6,9,12,18,24,36,48, 54 MBPS)	802.11n HT20 RATES (MCS 0 MCS 15)	802.11n HT40 RATES (MCS 0 MCS15)
1		17	19	19	
2		17	19	19	
3	(1, 5)	17	19	19	22
4	(2, 6)	17	19	19	22
5	(3, 7)	17	19	19	22
6	(4, 8)	17	19	19	22
7	(5, 9)	17	19	19	22
8	(6, 10)	17	19	19	22
9	(7, 11)	17	19	19	22
10	(8, 12)	17	19	19	22
11	(9, 13)	17	19	19	22
12		17	19	19	
13		17	19	19	
14					

Internal (dual-band) antenna with peak gain = 3dBi

AP-621 Japan Domain 2.4 GHz Panel Antenna Model

The following is an AP-621 standard transmit power table (Japan domain) per panel antenna in the 2.4GHz band:

20 MHZ CHANNEL	40 MHZ CHANNEL	LEGACY DSSS RATES (1, 2, 5.5, 11 MBPS)	LEGACY OFDM RATES (6,9,12,18,24,36,48, 54 MBPS)	802.11n HT20 RATES (MCS 0 MCS 15)	802.11n HT40 RATES (MCS 0 MCS15)
1		16	17	17	
2		16	19	17	
3	(1, 5)	16	17	17	20
4	(2, 6)	16	17	17	20
5	(3, 7)	16	17	17	20
6	(4, 8)	16	17	17	20
7	(5, 9)	16	17	17	20

20 MHZ CHANNEL	40 MHZ CHANNEL	LEGACY DSSS RATES (1, 2, 5.5, 11 MBPS)	LEGACY OFDM RATES (6,9,12,18,24,36,48, 54 MBPS)	802.11n HT20 RATES (MCS 0 MCS 15)	802.11n HT40 RATES (MCS 0 MCS15)
8	(6, 10)	16	17	17	20
9	(7, 11)	16	17	17	20
10	(8, 12)	16	17	17	20
11	(9, 13)	16	17	17	20
12		16	17	17	
13		16	17	17	
14					

Panel antenna with peak gain = 4.5dBi

AP-621 Japan Domain 2.4 GHz Patch Antenna Model

The following is an AP-621 standard transmit power table (Japan domain) per patch antenna in the 2.4GHz band:

20 MHZ CHANNEL	40 MHZ CHANNEL	LEGACY DSSS RATES (1, 2, 5.5, 11 MBPS)	LEGACY OFDM RATES (6,9,12,18,24,36,48, 54 MBPS)	802.11n HT20 RATES (MCS 0 MCS 15)	802.11n HT40 RATES (MCS 0 MCS15)
1		17	19	19	
2		17	19	19	
3	(1, 5)	17	19	19	22
4	(2, 6)	17	19	19	22
5	(3, 7)	17	19	19	22
6	(4, 8)	17	19	19	22
7	(5, 9)	17	19	19	22
8	(6, 10)	17	19	19	22
9	(7, 11)	17	19	19	22
10	(8, 12)	17	19	19	22
11	(9, 13)	17	19	19	22
12		17	19	19	
13		17	19	19	
14					

Patch antenna with peak gain = 5dBi

AP-621 (Standard Power) Japan Regulatory Domain 5GHz Band

The following are AP-621 standard power tables (Japan domain) per listed antenna in the 5GHz band:

AP-621 Japan Domain 5 GHz Dipole (Dual-Band) or Outdoor Omni Dipole Antenna Model Maximum Conducted Transmit Power Settings

The following is an AP-621 standard transmit power table (Japan domain) per dipole (dual-band) or outdoor omni dipole antenna in the 5GHz band:

20 MHZ CHANNEL	40 MHZ CHANNEL	LEGACY OFDM RATES (6,9,12,18,24,36,48,54 MBPS)	802.11n HT20 RATES (MCS 0 MCS 15)	802.11n HT40 RATES (MCS 0 MCS 15)
36		10.0	12.5	
38	(36, 40)	12.5	12.5	12.5
40		12.5	12.5	
42		12.5	12.5	
44		12.5	12.5	
46	(44, 48)	12.5	12.5	12.5
48		12.5	12.5	
52		12.5	12.5	
54	(52, 56)	12.5	12.5	12.5
56		12.5	12.5	
60		12.5	12.5	
62	(60, 64)	12.5	12.5	12.5
64		12.5	12.5	
100		18.0	18.0	
102	(100, 104)	18.0	18.0	18.0
104		18.0	18.0	
108		18.0	18.0	
112		18.0	18.0	
110	(108, 112)	18.0	18.0	18.0
116		18.0	18.0	
118	(116, 120)	18.0	18.0	18.0
120		18.0	18.0	
124		18.0	18.0	
126	(124, 128)	18.0	18.0	18.0
128		18.0	18.0	
132		18.0	18.0	
134	(132, 136)	18.0	18.0	18.0

20 MHZ CHANNEL	40 MHZ CHANNEL	LEGACY OFDM RATES (6,9,12,18,24,36,48,54 MBPS)	802.11n HT20 RATES (MCS 0 MCS 15)	802.11n HT40 RATES (MCS 0 MCS 15)
136		18.0	18.0	
140		18.0	18.0	
149				
151	(149, 153)			
153				
157				
159	(157, 161)			
161				
165				

Dipole (dual-band) or outdoor omni dipole antenna with peak gain = 5dBi

AP-621 Japan Domain 5 GHz Internal (Dual-Band) Antenna Model Maximum Conducted Transmit Power Settings

The following is an AP-621 standard transmit power table (Japan domain) per internal (dual-band) antenna in the 5GHz band:

20 MHZ CHANNEL	40 MHZ CHANNEL	LEGACY OFDM RATES (6,9,12,18,24,36,48,54 MBPS)	802.11n HT20 RATES (MCS 0 MCS 15)	802.11n HT40 RATES (MCS 0 MCS 15)
36		11.5	11.5	
38	(36, 40)	11.5	11.5	11.5
40		11.5	11.5	
42		11.5	11.5	
44		11.5	11.5	
46	(44, 48)	11.5	11.5	11.5
48		11.5	11.5	
52		11.5	11.5	
54	(52, 56)	11.5	11.5	11.5
56		11.5	11.5	
60		11.5	11.5	
62	(60, 64)	11.5	11.5	11.5
64		11.5	11.5	
100		17.0	17.0	
102	(100, 104)	17.0	17.0	17.0
104		17.0	17.0	

20 MHZ CHANNEL	40 MHZ CHANNEL	LEGACY OFDM RATES (6,9,12,18,24,36,48,54 MBPS)	802.11n HT20 RATES (MCS 0 MCS 15)	802.11n HT40 RATES (MCS 0 MCS 15)
108		17.0	17.0	
112		17.0	17.0	
110	(108, 112)	17.0	17.0	17.0
116		17.0	17.0	
118	(116, 120)	17.0	17.0	17.0
120		17.0	17.0	
124		17.0	17.0	
126	(124, 128)	17.0	17.0	17.0
128		17.0	17.0	
132		17.0	17.0	
134	(132, 136)	17.0	17.0	17.0
136		17.0	17.0	
140		17.0	17.0	
149				
151	(149, 153)			
153				
157				
159	(157, 161)			
161				
165				

Internal (dual-band) antenna with peak gain = 6dBi

AP-621 Japan Domain 5 GHz Panel Antenna Model Maximum Conducted Transmit Power Settings

The following is an AP-621 standard transmit power table (Japan domain) per panel antenna in the 5GHz band:

20 MHZ CHANNEL	40 MHZ CHANNEL	LEGACY OFDM RATES (6,9,12,18,24,36,48,54 MBPS)	802.11n HT20 RATES (MCS 0 MCS 15)	802.11n HT40 RATES (MCS 0 MCS 15)
36		12.5	12.5	
38	(36, 40)	12.5	12.5	12.5
40		12.5	12.5	
42		12.5	12.5	
44		12.5	12.5	

20 MHZ CHANNEL	40 MHZ CHANNEL	LEGACY OFDM RATES (6,9,12,18,24,36,48,54 MBPS)	802.11n HT20 RATES (MCS 0 MCS 15)	802.11n HT40 RATES (MCS 0 MCS 15)
46	(44, 48)	12.5	12.5	12.5
48		12.5	12.5	
52		12.5	12.5	
54	(52, 56)	12.5	12.5	12.5
56		12.5	12.5	
60		12.5	12.5	
62	(60, 64)	12.5	12.5	12.5
64		12.5	12.5	
100		18.0	18.0	
102	(100, 104)	18.0	18.0	18.0
104		18.0	18.0	
108		18.0	18.0	
112		18.0	18.0	
110	(108, 112)	18.0	18.0	18.0
116		18.0	18.0	
118	(116, 120)	18.0	18.0	18.0
120		18.0	18.0	
124		18.0	18.0	
126	(124, 128)	18.0	18.0	18.0
128		18.0	18.0	
132		18.0	18.0	
134	(132, 136)	18.0	18.0	18.0
136		18.0	18.0	
140		18.0	18.0	
149				
151	(149, 153)			
153				
157				
159	(157, 161)			
161				
165				

Panel antenna with peak gain = 5dBi

AP-621 Japan Domain 5 GHz Patch Antenna Model Maximum Conducted Transmit Power Settings

The following is an AP-621 standard transmit power table (Japan domain) per patch antenna in the 5GHz band:

20 MHZ CHANNEL	40 MHZ CHANNEL	LEGACY OFDM RATES (6,9,12,18,24,36,48,54 MBPS)	802.11n HT20 RATES (MCS 0 MCS 15)	802.11n HT40 RATES (MCS 0 MCS 15)
36		13.5	13.5	
38	(36, 40)	13.5	13.5	13.5
40		13.5	13.5	
42		13.5	13.5	
44		13.5	13.5	
46	(44, 48)	13.5	13.5	12.5
48		13.5	13.5	
52		13.5	13.5	
54	(52, 56)	13.5	13.5	13.5
56		13.5	13.5	
60		13.5	13.5	
62	(60, 64)	13.5	13.5	13.5
64		13.5	13.5	
100		19.0	19.0	
102	(100, 104)	19.0	19.0	19.0
104		19.0	19.0	
108		19.0	19.0	
112		19.0	19.0	
110	(108, 112)	19.0	19.0	19.0
116		19.0	19.0	
118	(116, 120)	19.0	19.0	19.0
120		19.0	19.0	
124		19.0	19.0	
126	(124, 128)	19.0	19.0	19.0
128		19.0	19.0	
132		19.0	19.0	
134	(132, 136)	19.0	19.0	19.0
136		19.0	19.0	
140		19.0	19.0	
149				

20 MHZ CHANNEL	40 MHZ CHANNEL	LEGACY OFDM RATES (6,9,12,18,24,36,48,54 MBPS)	802.11n HT20 RATES (MCS 0 MCS 15)	802.11n HT40 RATES (MCS 0 MCS 15)
151	(149, 153)			
153				
157				
159	(157, 161)			
161				
165				

Patch antenna with peak gain = 4dBi

AP-6521 (High Power) Japan Regulatory Domain 2.4GHz Band

The following are AP-6521 high power transmit tables (Japan domain) per listed antenna in the 2.4GHz band:

AP-6521 Japan Domain 2.4 GHz Dipole (Dual-Band) or Outdoor Omni Dipole Antenna Model

The following is an AP-6521 high transmit power table (Japan domain) per dipole (dual-band) or outdoor omni dipole antenna in the 2.4GHz band:

20 MHZ CHANNEL	40 MHZ CHANNEL	LEGACY DSSS RATES (1, 2, 5.5, 11 MBPS)	LEGACY OFDM RATES (6,9,12,18,24,36,48, 54 MBPS)	802.11n HT20 RATES (MCS 0 MCS 15)	802.11n HT40 RATES (MCS 0 MCS15)
1		17	19	19	
2		17	19	19	
3	(1, 5)	17	19	19	22
4	(2, 6)	17	19	19	22
5	(3, 7)	17	19	19	22
6	(4, 8)	17	19	19	22
7	(5, 9)	17	19	19	22
8	(6, 10)	17	19	19	22
9	(7, 11)	17	19	19	22
10	(8, 12)	17	19	19	22
11	(9, 13)	17	19	19	22
12		17	19	19	
13		17	19	19	
14					

Dipole (dual-band) or outdoor omni dipole antenna with peak gain = 3dBi

AP-6521 Japan Domain 2.4 GHz Internal (Dual-Band) Antenna Model

The following is an AP-6521 high transmit power table (Japan domain) per internal (dual-band) antenna in the 2.4GHz band:

20 MHZ CHANNEL	40 MHZ CHANNEL	LEGACY DSSS RATES (1, 2, 5.5, 11 MBPS)	LEGACY OFDM RATES (6,9,12,18,24,36,48, 54 MBPS)	802.11n HT20 RATES (MCS 0 MCS 15)	802.11n HT40 RATES (MCS 0 MCS15)
1		17	19	19	
2		17	19	19	
3	(1, 5)	17	19	19	22
4	(2, 6)	17	19	19	22
5	(3, 7)	17	19	19	22
6	(4, 8)	17	19	19	22
7	(5, 9)	17	19	19	22
8	(6, 10)	17	19	19	22
9	(7, 11)	17	19	19	22
10	(8, 12)	17	19	19	22
11	(9, 13)	17	19	19	22
12		17	19	19	
13		17	19	19	
14					

Internal (dual-band) antenna with peak gain = 3dBi

AP-6521 Japan Domain 2.4 GHz Panel Antenna Model

The following is an AP-6521 high transmit power table (Japan domain) per panel antenna in the 2.4GHz band:

20 MHZ CHANNEL	40 MHZ CHANNEL	LEGACY DSSS RATES (1, 2, 5.5, 11 MBPS)	LEGACY OFDM RATES (6,9,12,18,24,36,48, 54 MBPS)	802.11n HT20 RATES (MCS 0 MCS 15)	802.11n HT40 RATES (MCS 0 MCS15)
1		16	17	17	
2		16	17	17	
3	(1, 5)	16	17	17	20
4	(2, 6)	16	17	17	20
5	(3, 7)	16	17	17	20

20 MHZ CHANNEL	40 MHZ CHANNEL	LEGACY DSSS RATES (1, 2, 5.5, 11 MBPS)	LEGACY OFDM RATES (6,9,12,18,24,36,48, 54 MBPS)	802.11n HT20 RATES (MCS 0 MCS 15)	802.11n HT40 RATES (MCS 0 MCS15)
6	(4, 8)	16	17	17	20
7	(5, 9)	16	17	17	20
8	(6, 10)	16	17	17	20
9	(7, 11)	16	17	17	20
10	(8, 12)	16	17	17	20
11	(9, 13)	16	17	17	20
12		16	17	17	
13		16	17	17	
14					

Panel antenna with peak gain = 4.5dBi

AP-6521 Japan Domain 2.4 GHz Patch Antenna Model

The following is an AP-6521 high transmit power table (Japan domain) per patch antenna in the 2.4GHz band:

20 MHZ CHANNEL	40 MHZ CHANNEL	LEGACY DSSS RATES (1, 2, 5.5, 11 MBPS)	LEGACY OFDM RATES (6,9,12,18,24,36,48, 54 MBPS)	802.11n HT20 RATES (MCS 0 MCS 15)	802.11n HT40 RATES (MCS 0 MCS15)
1		17	19	19	
2		17	19	19	
3	(1, 5)	17	19	19	22
4	(2, 6)	17	19	19	22
5	(3, 7)	17	19	19	22
6	(4, 8)	17	19	19	22
7	(5, 9)	17	19	19	22
8	(6, 10)	17	19	19	22
9	(7, 11)	17	19	19	22
10	(8, 12)	17	19	19	22
11	(9, 13)	17	19	19	22
12		17	19	19	
13		17	19	19	
14					

Patch antenna with peak gain = 3dBi

AP-6521 (High Power) Japan Regulatory Domain 5GHz Band

The following are AP-6521 high power tables (Japan domain) per listed antenna in the 5GHz band:

AP-6521 Japan Domain 5 GHz Dipole (Dual-Band) or Outdoor Omni Dipole Antenna Model Maximum Conducted Transmit Power Settings

The following is an AP-6521 high transmit power table (Japan domain) per dipole (dual-band) or outdoor omni dipole antenna in the 5GHz band:

20 MHZ CHANNEL	40 MHZ CHANNEL	LEGACY OFDM RATES (6,9,12,18,24,36,48,54 MBPS)	802.11n HT20 RATES (MCS 0 MCS 15)	802.11n HT40 RATES (MCS 0 MCS 15)
36		10.0	12.5	
38	(36, 40)	12.5	12.5	12.5
40		12.5	12.5	
42		12.5	12.5	
44		12.5	12.5	
46	(44, 48)	12.5	12.5	12.5
48		12.5	12.5	
52		12.5	12.5	
54	(52, 56)	12.5	12.5	12.5
56		12.5	12.5	
60		12.5	12.5	
62	(60, 64)	12.5	12.5	12.5
64		12.5	12.5	
100		18.0	18.0	
102	(100, 104)	18.0	18.0	18.0
104		18.0	18.0	
108		18.0	18.0	
112		18.0	18.0	
110	(108, 112)	18.0	18.0	18.0
116		18.0	18.0	
118	(116, 120)	18.0	18.0	18.0
120		18.0	18.0	
124		18.0	18.0	
126	(124, 128)	18.0	18.0	18.0
128		18.0	18.0	
132		18.0	18.0	
134	(132, 136)	18.0	18.0	18.0

20 MHZ CHANNEL	40 MHZ CHANNEL	LEGACY OFDM RATES (6,9,12,18,24,36,48,54 MBPS)	802.11n HT20 RATES (MCS 0 MCS 15)	802.11n HT40 RATES (MCS 0 MCS 15)
136		18.0	18.0	
140		18.0	18.0	
149				
151	(149, 153)			
153				
157				
159	(157, 161)			
161				
165				

Dipole (dual-band) or outdoor omni dipole antenna with peak gain = 5dBi

AP-6521 Japan Domain 5 GHz Internal (Dual-Band) Antenna Model Maximum Conducted Transmit Power Settings

The following is an AP-6521 high transmit power table (Japan domain) per internal (dual-band) antenna in the 5GHz band:

20 MHZ CHANNEL	40 MHZ CHANNEL	LEGACY OFDM RATES (6,9,12,18,24,36,48,54 MBPS)	802.11n HT20 RATES (MCS 0 MCS 15)	802.11n HT40 RATES (MCS 0 MCS 15)
36		11.5	11.5	
38	(36, 40)	11.5	11.5	11.5
40		11.5	11.5	
42		11.5	11.5	
44		11.5	11.5	
46	(44, 48)	11.5	11.5	11.5
48		11.5	11.5	
52		11.5	11.5	
54	(52, 56)	11.5	11.5	11.5
56		11.5	11.5	
60		11.5	11.5	
62	(60, 64)	11.5	11.5	11.5
64		11.5	11.5	
100		17.0	17.0	
102	(100, 104)	17.0	17.0	17.0
104		17.0	17.0	

20 MHZ CHANNEL	40 MHZ CHANNEL	LEGACY OFDM RATES (6,9,12,18,24,36,48,54 MBPS)	802.11n HT20 RATES (MCS 0 MCS 15)	802.11n HT40 RATES (MCS 0 MCS 15)
108		17.0	17.0	
112		17.0	17.0	
110	(108, 112)	17.0	17.0	17.0
116		17.0	17.0	
118	(116, 120)	17.0	17.0	17.0
120		17.0	17.0	
124		17.0	17.0	
126	(124, 128)	17.0	17.0	17.0
128		17.0	17.0	
132		17.0	17.0	
134	(132, 136)	17.0	17.0	17.0
136		17.0	17.0	
140		17.0	17.0	
149				
151	(149, 153)			
153				
157				
159	(157, 161)			
161				
165				

Internal (dual-band) antenna with peak gain = 6dBi

AP-6521 Japan Domain 5 GHz Panel Antenna Model Maximum Conducted Transmit Power Settings

The following is an AP-6521 high transmit power table (Japan domain) per panel antenna in the 5GHz band:

20 MHZ CHANNEL	40 MHZ CHANNEL	LEGACY OFDM RATES (6,9,12,18,24,36,48,54 MBPS)	802.11n HT20 RATES (MCS 0 MCS 15)	802.11n HT40 RATES (MCS 0 MCS 15)
36		12.5	12.5	
38	(36, 40)	12.5	12.5	12.5
40		12.5	12.5	
42		12.5	12.5	
44		12.5	12.5	

20 MHZ CHANNEL	40 MHZ CHANNEL	LEGACY OFDM RATES (6,9,12,18,24,36,48,54 MBPS)	802.11n HT20 RATES (MCS 0 MCS 15)	802.11n HT40 RATES (MCS 0 MCS 15)
46	(44, 48)	12.5	12.5	12.5
48		12.5	12.5	
52		12.5	12.5	
54	(52, 56)	12.5	12.5	12.5
56		12.5	12.5	
60		12.5	12.5	
62	(60, 64)	12.5	12.5	12.5
64		12.5	12.5	
100		18.0	18.0	
102	(100, 104)	18.0	18.0	18.0
104		18.0	18.0	
108		18.0	18.0	
112		18.0	18.0	
110	(108, 112)	18.0	18.0	18.0
116		18.0	18.0	
118	(116, 120)	18.0	18.0	18.0
120		18.0	18.0	
124		18.0	18.0	
126	(124, 128)	18.0	18.0	18.0
128		18.0	18.0	
132		18.0	18.0	
134	(132, 136)	18.0	18.0	18.0
136		18.0	18.0	
140		18.0	18.0	
149				
151	(149, 153)			
153				
157				
159	(157, 161)			
161				
165				

Panel antenna with peak gain = 5dBi

AP-6521 Japan Domain 5 GHz Patch Antenna Model Maximum Conducted Transmit Power Settings

The following is an AP-6521 high transmit power table (Japan domain) per patch antenna in the 5GHz band:

20 MHZ CHANNEL	40 MHZ CHANNEL	LEGACY OFDM RATES (6,9,12,18,24,36,48,54 MBPS)	802.11n HT20 RATES (MCS 0 MCS 15)	802.11n HT40 RATES (MCS 0 MCS 15)
36		13.5	13.5	
38	(36, 40)	13.5	13.5	13.5
40		13.5	13.5	
42		13.5	13.5	
44		13.5	13.5	
46	(44, 48)	13.5	13.5	13.5
48		13.5	13.5	
52		13.5	13.5	
54	(52, 56)	13.5	13.5	13.5
56		13.5	13.5	
60		13.5	13.5	
62	(60, 64)	13.5	13.5	13.5
64		13.5	13.5	
100		19.0	19.0	
102	(100, 104)	19.0	19.0	19.0
104		19.0	19.0	
108		19.0	19.0	
112		19.0	19.0	
110	(108, 112)	19.0	19.0	19.0
116		19.0	19.0	
118	(116, 120)	19.0	19.0	19.0
120		19.0	19.0	
124		19.0	19.0	
126	(124, 128)	19.0	19.0	19.0
128		19.0	19.0	
132		19.0	19.0	
134	(132, 136)	19.0	19.0	19.0
136		19.0	19.0	
140		19.0	19.0	
149				

20 MHZ CHANNEL	40 MHZ CHANNEL	LEGACY OFDM RATES (6,9,12,18,24,36,48,54 MBPS)	802.11n HT20 RATES (MCS 0 MCS 15)	802.11n HT40 RATES (MCS 0 MCS 15)
151	(149, 153)			
153				
157				
159	(157, 161)			
161				
165				

Patch antenna with peak gain = 4dBi

15 AP622, AP6522 and AP6562 Regulatory Domains

AP622, AP6522, AP6562 US Regulatory Domain 2.4 GHz Band
 AP622, AP6522, AP6562 US Regulatory Domain 5 GHz Band
 AP622, AP6522, AP6562 EU Regulatory Domain 2.4 GHz Band
 AP622, AP6522, AP6562 EU Regulatory Domain 5 GHz Band
 AP622, AP6522, AP6562 Japan Regulatory Domain 2.4 GHz Band
 AP622, AP6522, AP6562 Japan Regulatory Domain 5 GHz Band

AP622, AP6522, AP6562 US Regulatory Domain 2.4 GHz Band

AP622, AP6522, AP6562 US Domain 2.4 GHz Internal Antenna Maximum Conducted Transmit Power Settings

The following is a transmit power table (US domain) per internal antenna in the 2.4 GHz band:

20 MHZ CHANNEL	40 MHZ CHANNEL	LEGACY DSSS RATES (1, 2, 5.5, 11 MBPS)	LEGACY OFDM RATES (6,9,12,18,24,36,48,54 MBPS)	802.11n HT20 RATES (MCS 0 MCS 15)	802.11n HT40 RATES (MCS 0 MCS15)
1		21.0	16.0	14.0	
2		21.0	21.0	21.0	
3	(1, 5)	21.0	21.0	21.0	11.5
4	(2, 6)	21.0	21.0	21.0	14.5
5	(3, 7)	21.0	21.0	21.0	14.5
6	(4, 8)	21.0	21.0	21.0	14.5
7	(5, 9)	21.0	21.0	21.0	14.5
8	(6, 10)	21.0	21.0	21.0	14.5
9	(7, 11)	21.0	21.0	21.0	13.0
10	(8, 12)	21.0	21.0	21.0	
11	(9, 13)	20.5	15.5	13.5	

Internal antenna, peak gain = 3.9dBi

AP622, AP6522, AP6562 US Domain 2.4 GHz Dipole Omni Antenna Maximum Conducted Transmit Power Settings

The following is a transmit power table (US domain) per dipole omni antenna in the 2.4 GHz band:

20 MHZ CHANNEL	40 MHZ CHANNEL	LEGACY DSSS RATES (1, 2, 5.5, 11 MBPS)	LEGACY OFDM RATES (6,9,12,18,24,36,48,54 MBPS)	802.11n HT20 RATES (MCS 0 MCS 15)	802.11n HT40 RATES (MCS 0 MCS15)
1		21.0	15.5	15.0	
2		21.0	21.0	21.0	
3	(1, 5)	21.0	21.0	21.0	12.0
4	(2, 6)	21.0	21.0	21.0	15.0
5	(3, 7)	21.0	21.0	21.0	15.0
6	(4, 8)	21.0	21.0	21.0	15.0
7	(5, 9)	21.0	21.0	21.0	15.0
8	(6, 10)	21.0	21.0	21.0	15.0
9	(7, 11)	21.0	21.0	21.0	11.5
10	(8, 12)	21.0	21.0	21.0	
11	(9, 13)	20.5	16.0	13.0	

Dipole omni antenna, peak gain = 8.5dBi

AP622, AP6522, AP6562 US Domain 2.4 GHz Panel Antenna Maximum Conducted Transmit Power Settings

The following is a transmit power table (US domain) per panel antenna in the 2.4 GHz band:

20 MHZ CHANNEL	40 MHZ CHANNEL	LEGACY DSSS RATES (1, 2, 5.5, 11 MBPS)	LEGACY OFDM RATES (6,9,12,18,24,36,48,54 MBPS)	802.11n HT20 RATES (MCS 0 MCS 15)	802.11n HT40 RATES (MCS 0 MCS15)
1		18.0	13.0	12.5	
2		20.0	14.0	14.5	
3	(1, 5)	20.0	14.0	14.5	8.5
4	(2, 6)	20.0	14.0	14.5	13.0
5	(3, 7)	20.0	14.0	14.5	13.0
6	(4, 8)	20.0	14.0	14.5	13.0
7	(5, 9)	20.0	14.0	14.5	13.0
8	(6, 10)	20.0	14.0	14.5	13.0
9	(7, 11)	20.0	14.0	14.5	8.0
10	(8, 12)	20.0	14.0	14.5	
11	(9, 13)	16.5	11.5	11.0	

Panel antenna, peak gain = 10.9dBi

AP622, AP6522, AP6562 US Domain 2.4 GHz Patch Antenna Maximum Conducted Transmit Power Settings

The following is a transmit power table (US domain) per patch antenna in the 2.4 GHz band:

20 MHZ CHANNEL	40 MHZ CHANNEL	LEGACY DSSS RATES (1, 2, 5.5, 11 MBPS)	LEGACY OFDM RATES (6,9,12,18,24,36,48,54 MBPS)	802.11n HT20 RATES (MCS 0 MCS 15)	802.11n HT40 RATES (MCS 0 MCS15)
1		21.0	20.5	20.0	
2		21.0	21.0	21.0	
3	(1, 5)	21.0	21.0	21.0	17.5
4	(2, 6)	21.0	21.0	21.0	19.5
5	(3, 7)	21.0	21.0	21.0	19.5
6	(4, 8)	21.0	21.0	21.0	19.5
7	(5, 9)	21.0	21.0	21.0	19.5
8	(6, 10)	21.0	21.0	21.0	19.5
9	(7, 11)	21.0	21.0	21.0	14.5
10	(8, 12)	21.0	21.0	21.0	
11	(9, 13)	21.0	19.5	18.5	

Patch antenna, peak gain = 3.5dBi

AP622, AP6522, AP6562 US Domain 2.4 GHz Yagi Antenna Maximum Conducted Transmit Power Settings

The following is a transmit power table (US domain) per yagi antenna in the 2.4 GHz band:

20 MHZ CHANNEL	40 MHZ CHANNEL	LEGACY DSSS RATES (1, 2, 5.5, 11 MBPS)	LEGACY OFDM RATES (6,9,12,18,24,36,48,54 MBPS)	802.11n HT20 RATES (MCS 0 MCS 15)	802.11n HT40 RATES (MCS 0 MCS15)
1		21.0	18.0	17.5	
2		21.0	21.0	21.0	
3	(1, 5)	21.0	21.0	21.0	14.5
4	(2, 6)	21.0	21.0	21.0	19.0
5	(3, 7)	21.0	21.0	21.0	19.0
6	(4, 8)	21.0	21.0	21.0	19.0
7	(5, 9)	21.0	21.0	21.0	19.0
8	(6, 10)	21.0	21.0	21.0	19.0

20 MHZ CHANNEL	40 MHZ CHANNEL	LEGACY DSSS RATES (1, 2, 5.5, 11 MBPS)	LEGACY OFDM RATES (6,9,12,18,24,36,48,54 MBPS)	802.11n HT20 RATES (MCS 0 MCS 15)	802.11n HT40 RATES (MCS 0 MCS15)
9	(7, 11)	21.0	21.0	21.0	14.0
10	(8, 12)	21.0	21.0	21.0	
11	(9, 13)	20.0	17.0	16.0	

Yagi antenna, peak gain = 11.1dBi

AP622, AP6522, AP6562 US Regulatory Domain 5 GHz Band

Dipole omni antenna, peak gain = 9dBi

AP622, AP6522, AP6562 US Domain 5 GHz Internal Antenna Model

The following is a transmit power table (US domain) per internal antenna in the 5 GHz band:

20 MHZ CHANNEL	40 MHZ CHANNEL	LEGACY OFDM RATES (6,9,12,18,24,36,48,54 MBPS)	802.11n HT20 RATES (MCS 0 MCS 15)	802.11n HT40 RATES (MCS 0 MCS 15)
36		10.5	13.5	
38	(36, 40)			13.0
40		11.0	13.0	
44		11.5	13.0	
46	(44, 48)			13.0
48		11.5	13.0	
52		19.0	20.0	
54	(52, 56)			20.0
56		18.5	20.0	
60		19.0	20.0	
62	(60, 64)			19.0
64		19.0	19.0	
100		20.0	18.0	
102	(100, 104)			17.0
104		20.0	19.0	
108		20.0	19.0	
110				18.5
112	(108, 112)	20.0	19.0	
116		20.0	19.0	
118	(116, 120)			

20 MHZ CHANNEL	40 MHZ CHANNEL	LEGACY OFDM RATES (6,9,12,18,24,36,48,54 MBPS)	802.11n HT20 RATES (MCS 0 MCS 15)	802.11n HT40 RATES (MCS 0 MCS 15)
120				
124				
126	(124, 128)			
128				
132				
134	(132, 136)			20.0
136		20.0	19.0	
140		18.5	20.0	
149		20.0	20.0	
151	(149, 153)			20.0
153		20.0	20.0	
157		20.0	20.0	
159	(157, 161)			20.0
161		20.0	20.0	
165		20.0	20.0	

Internal antenna, peak gain = 7.5dBi

AP622, AP6522, AP6562 US Domain 5 GHz Dipole Omni Antenna Model

The following is a transmit power table (US domain) per dipole omni antenna in the 5 GHz band:

20 MHZ CHANNEL	40 MHZ CHANNEL	LEGACY OFDM RATES (6,9,12,18,24,36,48,54 MBPS)	802.11n HT20 RATES (MCS 0 MCS 15)	802.11n HT40 RATES (MCS 0 MCS 15)
36		10.0	10.0	
38	(36, 40)			9.5
40		10.0	10.0	
44		10.0	10.0	
46	(44, 48)			10.0
48		10.5	10.5	
52		15.0	15.0	
54	(52, 56)			14.5
56		15.0	15.0	
60		15.0	15.0	
62	(60, 64)			14.5

20 MHZ CHANNEL	40 MHZ CHANNEL	LEGACY OFDM RATES (6,9,12,18,24,36,48,54 MBPS)	802.11n HT20 RATES (MCS 0 MCS 15)	802.11n HT40 RATES (MCS 0 MCS 15)
64		15.0	15.0	
100		15.0	15.0	
102	(100, 104)			15.0
104		15.0	15.0	
108		15.0	15.0	
110				14.5
112	(108, 112)	15.0	15.0	
116		15.0	15.0	
118	(116, 120)			
120				
124				
126	(124, 128)			
128				
132				
134	(132, 136)			20.0
136		15.0	15.0	
140		15.0	15.0	
149		20.0	20.0	
151	(149, 153)			20.0
153		20.0	20.0	
157		20.0	20.0	
159	(157, 161)			20.0
161		20.0	20.0	
165		20.0	20.0	

Dipole omni antenna, peak gain = 9dBi

AP622, AP6522, AP6562 US Domain 5 GHz Panel Antenna Model

The following is a transmit power table (US domain) per panel antenna in the 5 GHz band:

20 MHZ CHANNEL	40 MHZ CHANNEL	LEGACY OFDM RATES (6,9,12,18,24,36,48,54 MBPS)	802.11n HT20 RATES (MCS 0 MCS 15)	802.11n HT40 RATES (MCS 0 MCS 15)
36		11.5	11.0	
38	(36, 40)			10.5

20 MHZ CHANNEL	40 MHZ CHANNEL	LEGACY OFDM RATES (6,9,12,18,24,36,48,54 MBPS)	802.11n HT20 RATES (MCS 0 MCS 15)	802.11n HT40 RATES (MCS 0 MCS 15)
40		11.5	11.0	
44		11.5	11.0	
46	(44, 48)			11.0
48		11.5	11.5	
52		15.5	16.0	
54	(52, 56)			15.5
56		15.5	16.0	
60		15.5	16.0	
62	(60, 64)			10.0
64		15.5	15.5	
100		15.5	15.5	
102	(100, 104)			15.0
104		15.5	15.0	
108		15.5	15.0	
110				14.5
112	(108, 112)	15.5	15.0	
116		15.0	15.0	
118	(116, 120)			
120				
124				
126	(124, 128)			
128				
132				
134	(132, 136)			15.5
136		15.0	15.0	
140		13.0	12.0	
149		20.0	19.0	
151	(149, 153)			19.0
153		20.0	20.0	
157		20.0	20.0	
159	(157, 161)			20.0
161		20.0	20.0	
165		20.0	20.0	

Panel antenna, peak gain = 12.5dBi

AP622, AP6522, AP6562 US Domain 5 GHz Patch Antenna Model

The following is a transmit power table (US domain) per patch antenna in the 5 GHz band:

20 MHZ CHANNEL	40 MHZ CHANNEL	LEGACY OFDM RATES (6,9,12,18,24,36,48,54 MBPS)	802.11n HT20 RATES (MCS 0 MCS 15)	802.11n HT40 RATES (MCS 0 MCS 15)
36		14.0	14.0	
38	(36, 40)			13.5
40		14.5	14.5	
44		14.5	14.5	
46	(44, 48)			14.5
48		15.0	15.0	
52		19.5	19.5	
54	(52, 56)			19.0
56		19.5	19.5	
60		19.5	19.5	
62	(60, 64)			17.5
64		19.5	19.5	
100		20.0	20.0	
102	(100, 104)			15.5
104		20.0	20.0	
108		20.0	20.0	
110				19.5
112	(108, 112)	20.0	20.0	
116		20.0	20.0	
118	(116, 120)			
120				
124				
126	(124, 128)			
128				
132				
134	(132, 136)			20.0
136		20.0	20.0	
140		17.5	17.5	
149		20.0	20.0	
151	(149, 153)			20.0

20 MHZ CHANNEL	40 MHZ CHANNEL	LEGACY OFDM RATES (6,9,12,18,24,36,48,54 MBPS)	802.11n HT20 RATES (MCS 0 MCS 15)	802.11n HT40 RATES (MCS 0 MCS 15)
153		20.0	20.0	
157		20.0	20.0	
159	(157, 161)			20.0
161		20.0	20.0	
165		20.0	20.0	

Patch antenna, peak gain = 4.6dBi

AP622, AP6522, AP6562 US Domain 5 GHz Yagi Antenna Model

The following is a transmit power table (US domain) per yagi antenna in the 5 GHz band:

20 MHZ CHANNEL	40 MHZ CHANNEL	LEGACY OFDM RATES (6,9,12,18,24,36,48,54 MBPS)	802.11n HT20 RATES (MCS 0 MCS 15)	802.11n HT40 RATES (MCS 0 MCS 15)
36		13.0	13.0	
38	(36, 40)			12.0
40		13.0	13.0	
44		13.0	13.0	
46	(44, 48)			12.5
48		13.5	13.5	
52		17.5	17.5	
54	(52, 56)			17.0
56		17.5	17.5	
60		17.5	17.5	
62	(60, 64)			16.0
64		17.5	17.5	
100		18.0	18.0	
102	(100, 104)			17.5
104		18.0	18.0	
108		18.0	18.0	
110				17.5
112	(108, 112)	17.5	17.5	
116		17.5	17.5	
118	(116, 120)			
120				

20 MHZ CHANNEL	40 MHZ CHANNEL	LEGACY OFDM RATES (6,9,12,18,24,36,48,54 MBPS)	802.11n HT20 RATES (MCS 0 MCS 15)	802.11n HT40 RATES (MCS 0 MCS 15)
124				
126	(124, 128)			
128				
132				
134	(132, 136)			18.0
136		18.0	18.0	
140		18.0	18.0	
149		20.0	20.0	
151	(149, 153)			20.0
153		20.0	20.0	
157		20.0	20.0	
159	(157, 161)			20.0
161		20.0	20.0	
165		20.0	20.0	

Yagi antenna, peak gain = 11.0dBi

AP622, AP6522, AP6562 EU Regulatory Domain 2.4 GHz Band

AP622, AP6522, AP6562 EU Domain 2.4 GHz Internal Antenna Model

The following is a transmit power table (EU domain) per internal antenna in the 2.4 GHz band:

20 MHZ CHANNEL	40 MHZ CHANNEL	LEGACY DSSS RATES (1, 2, 5.5, 11 MBPS)	LEGACY OFDM RATES (6,9,12,18,24,36,48,54 MBPS)	802.11n HT20 RATES (MCS 0 MCS 15)	802.11n HT40 RATES (MCS 0 MCS15)
1		16.0	13.5	13.5	
2		16.0	13.5	13.5	
3	(1, 5)	16.0	13.5	13.5	13.5
4	(2, 6)	16.0	13.5	13.5	13.5
5	(3, 7)	16.0	13.5	13.5	13.5
6	(4, 8)	16.0	13.5	13.5	13.5
7	(5, 9)	16.0	13.5	13.5	13.5
8	(6, 10)	16.0	13.5	13.5	13.5
9	(7, 11)	16.0	13.5	13.5	13.5
10	(8, 12)	16.0	13.5	13.5	13.5

20 MHZ CHANNEL	40 MHZ CHANNEL	LEGACY DSSS RATES (1, 2, 5.5, 11 MBPS)	LEGACY OFDM RATES (6,9,12,18,24,36,48,54 MBPS)	802.11n HT20 RATES (MCS 0 MCS 15)	802.11n HT40 RATES (MCS 0 MCS15)
11	(9, 13)	16.0	13.5	13.5	13.5
12		16.0	13.5	13.5	
13		16.0	13.5	13.5	

Internal antenna, peak gain = 3.9dBi

AP622, AP6522, AP6562 EU Domain 2.4 GHz Dipole Antenna Model

The following is a transmit power table (EU domain) per dipole antenna in the 2.4 GHz band:

20 MHZ CHANNEL	40 MHZ CHANNEL	LEGACY DSSS RATES (1, 2, 5.5, 11 MBPS)	LEGACY OFDM RATES (6,9,12,18,24,36,48,54 MBPS)	802.11n HT20 RATES (MCS 0 MCS 15)	802.11n HT40 RATES (MCS 0 MCS15)
1		9.0	6.0	6.0	
2		9.5	6.5	6.0	
3	(1, 5)	9.5	6.5	6.0	5.5
4	(2, 6)	9.5	6.5	6.0	6.0
5	(3, 7)	9.5	6.5	6.0	6.0
6	(4, 8)	9.5	6.5	6.0	6.0
7	(5, 9)	9.5	6.5	6.0	6.0
8	(6, 10)	9.5	6.5	6.0	6.0
9	(7, 11)	9.5	6.5	6.0	6.0
10	(8, 12)	9.5	6.5	6.0	6.0
11	(9, 13)	9.5	6.5	6.0	6.0
12		9.5	6.5	6.0	
13		9.0	6.0	6.0	

Dipole antenna, peak gain = 8.5dBi

AP622, AP6522, AP6562 EU Domain 2.4 GHz Panel Antenna Model

The following is a transmit power table (EU domain) per panel antenna in the 2.4 GHz band:

20 MHZ CHANNEL	40 MHZ CHANNEL	LEGACY DSSS RATES (1, 2, 5.5, 11 MBPS)	LEGACY OFDM RATES (6,9,12,18,24,36,48,54 MBPS)	802.11n HT20 RATES (MCS 0 MCS 15)	802.11n HT40 RATES (MCS 0 MCS15)
1		6.5	6.0	6.0	
2		6.5	6.5	6.5	
3	(1, 5)	6.5	6.5	6.5	6.0
4	(2, 6)	6.5	6.5	6.5	6.0
5	(3, 7)	6.5	6.5	6.5	6.0
6	(4, 8)	6.5	6.5	6.5	6.0
7	(5, 9)	6.5	6.5	6.5	6.0
8	(6, 10)	6.5	6.5	6.5	6.0
9	(7, 11)	6.5	6.5	6.5	6.0
10	(8, 12)	6.5	6.5	6.5	6.0
11	(9, 13)	6.5	6.5	6.5	6.0
12		6.5	6.5	6.5	
13		6.5	5.5	5.5	

Panel antenna, peak gain = 10.9dBi

AP622, AP6522, AP6562 EU Domain 2.4 GHz Patch Antenna Model

The following is a transmit power table (EU domain) per patch antenna in the 2.4 GHz band:

20 MHZ CHANNEL	40 MHZ CHANNEL	LEGACY DSSS RATES (1, 2, 5.5, 11 MBPS)	LEGACY OFDM RATES (6,9,12,18,24,36,48,54 MBPS)	802.11n HT20 RATES (MCS 0 MCS 15)	802.11n HT40 RATES (MCS 0 MCS15)
1		14.0	11.5	11.0	
2		14.5	12.0	11.0	
3	(1, 5)	14.5	12.0	11.0	10.5
4	(2, 6)	14.5	12.0	11.0	11.0
5	(3, 7)	14.5	12.0	11.0	11.0
6	(4, 8)	14.5	12.0	11.0	11.0
7	(5, 9)	14.5	12.0	11.0	11.0
8	(6, 10)	14.5	12.0	11.0	11.0
9	(7, 11)	14.5	12.0	11.0	11.0
10	(8, 12)	14.5	12.0	11.0	11.0
11	(9, 13)	14.5	12.0	11.0	11.5

20 MHZ CHANNEL	40 MHZ CHANNEL	LEGACY DSSS RATES (1, 2, 5.5, 11 MBPS)	LEGACY OFDM RATES (6,9,12,18,24,36,48,54 MBPS)	802.11n HT20 RATES (MCS 0 MCS 15)	802.11n HT40 RATES (MCS 0 MCS15)
12		14.5	12.0	11.0	
13		14.0	11.5	10.0	

Patch antenna, peak gain = 3.5dBi

AP622, AP6522, AP6562 EU Domain 2.4 GHz Yagi Antenna Model

The following is a transmit power table (EU domain) per yagi antenna in the 2.4 GHz band:

20 MHZ CHANNEL	40 MHZ CHANNEL	LEGACY DSSS RATES (1, 2, 5.5, 11 MBPS)	LEGACY OFDM RATES (6,9,12,18,24,36,48,54 MBPS)	802.11n HT20 RATES (MCS 0 MCS 15)	802.11n HT40 RATES (MCS 0 MCS15)
1		6.5	6.5	6.5	
2		6.5	6.5	6.5	
3	(1, 5)	6.5	6.5	6.5	6.5
4	(2, 6)	6.5	6.5	6.5	6.5
5	(3, 7)	6.5	6.5	6.5	6.5
6	(4, 8)	6.5	6.5	6.5	6.5
7	(5, 9)	6.5	6.5	6.5	6.5
8	(6, 10)	6.5	6.5	6.5	6.5
9	(7, 11)	6.5	6.5	6.5	6.5
10	(8, 12)	6.5	6.5	6.5	6.5
11	(9, 13)	6.5	6.5	6.5	6.5
12		6.5	6.5	6.5	
13		6.5	6.0	6.0	

Yagi antenna, peak gain = 11.1dBi

AP622, AP6522, AP6562 EU Regulatory Domain 5 GHz Band

AP622, AP6522, AP6562 EU Domain 5 GHz Internal Antenna Model

The following is a transmit power table (EU domain) per internal antenna in the 5 GHz band:

20 MHZ CHANNEL	40 MHZ CHANNEL	LEGACY OFDM RATES (6,9,12,18,24,36,48,54 MBPS)	802.11n HT20 RATES (MCS 0 MCS 15)	802.11n HT40 RATES (MCS 0 MCS 15)
36		13.5	13.5	
38	(36, 40)			13.0
40		13.5	13.5	
44		13.5	13.5	
46	(44, 48)			13.0
48		13.5	13.5	
52		10.5	10.5	
54	(52, 56)			10.5.0
56		10.5	10.5	
60		10.5	10.5	
62	(60, 64)			10.5
64		10.5	10.5	
100		18.0	18.0	
102	(100, 104)			18.0
104		18.0	18.0	
108		18.0	18.0	
110				18.0
112	(108, 112)	18.0	18.0	
116		18.0	18.0	
118	(116, 120)			
120				
124				
126	(124, 128)			
128				
132				
134	(132, 136)			18.0
136		18.0	18.0	
140		18.0	18.0	
149				
151	(149, 153)			
153				
157				
159	(157, 161)			

20 MHZ CHANNEL	40 MHZ CHANNEL	LEGACY OFDM RATES (6,9,12,18,24,36,48,54 MBPS)	802.11n HT20 RATES (MCS 0 MCS 15)	802.11n HT40 RATES (MCS 0 MCS 15)
161				
165				

Internal antenna, peak gain = 7.5dBi

AP622, AP6522, AP6562 EU Domain 5 GHz Dipole Omni Antenna Model

The following is a transmit power table (EU domain) per dipole omni antenna in the 5 GHz band:

20 MHZ CHANNEL	40 MHZ CHANNEL	LEGACY OFDM RATES (6,9,12,18,24,36,48,54 MBPS)	802.11n HT20 RATES (MCS 0 MCS 15)	802.11n HT40 RATES (MCS 0 MCS 15)
36		7.5	7.5	
38	(36, 40)			6.0
40		7.5	7.5	
44		7.5	7.5	
46	(44, 48)			6.0
48		7.5	7.5	
52		4.5	4.5	
54	(52, 56)			4.0
56		4.5	4.5	
60		4.5	4.5	
62	(60, 64)			4.0
64		4.5	4.5	
100		11.5	11.5	
102	(100, 104)			11.0
104		11.5	11.5	
108		11.5	11.5	
110				11.0
112	(108, 112)	11.5	11.5	
116		11.5	11.5	
118	(116, 120)			
120				
124				
126	(124, 128)			
128				

20 MHZ CHANNEL	40 MHZ CHANNEL	LEGACY OFDM RATES (6,9,12,18,24,36,48,54 MBPS)	802.11n HT20 RATES (MCS 0 MCS 15)	802.11n HT40 RATES (MCS 0 MCS 15)
132				
134	(132, 136)			11.0
136		11.0	11.0	
140		11.0	11.0	
149				
151	(149, 153)			
153				
157				
159	(157, 161)			
161				
165				

Dipole omni antenna, peak gain = 9dBi

AP622, AP6522, AP6562 EU Domain 5 GHz Panel Antenna Model

The following is a transmit power table (EU domain) per panel antenna in the 5 GHz band:

20 MHZ CHANNEL	40 MHZ CHANNEL	LEGACY OFDM RATES (6,9,12,18,24,36,48,54 MBPS)	802.11n HT20 RATES (MCS 0 MCS 15)	802.11n HT40 RATES (MCS 0 MCS 15)
36		6.0	6.0	
38	(36, 40)			6.0
40		6.0	6.0	
44		6.0	6.0	
46	(44, 48)			6.0
48		6.0	6.0	
52		3.5	3.5	
54	(52, 56)			3.5
56		3.5	3.5	
60		3.5	3.5	
62	(60, 64)			3.5
64		3.5	3.5	
100		9.0	9.0	
102	(100, 104)			8.5
104		9.0	9.0	

20 MHZ CHANNEL	40 MHZ CHANNEL	LEGACY OFDM RATES (6,9,12,18,24,36,48,54 MBPS)	802.11n HT20 RATES (MCS 0 MCS 15)	802.11n HT40 RATES (MCS 0 MCS 15)
108		9.0	9.0	
110				8.5
112	(108, 112)	9.0	9.0	
116		9.0	9.0	
118	(116, 120)			
120				
124				
126	(124, 128)			
128				
132				
134	(132, 136)			8.0
136		8.0	8.0	
140		8.0	8.0	
149				
151	(149, 153)			
153				
157				
159	(157, 161)			
161				
165				

Panel antenna, peak gain = 12.5dBi

AP622, AP6522, AP6562 EU Domain 5 GHz Patch Antenna Model

The following is a transmit power table (EU domain) per patch antenna in the 5 GHz band:

20 MHZ CHANNEL	40 MHZ CHANNEL	LEGACY OFDM RATES (6,9,12,18,24,36,48,54 MBPS)	802.11n HT20 RATES (MCS 0 MCS 15)	802.11n HT40 RATES (MCS 0 MCS 15)
36		11.5	11.5	
38	(36, 40)			11.0
40		11.5	11.5	
44		11.5	11.5	
46	(44, 48)			11.0
48		11.5	11.5	

20 MHZ CHANNEL	40 MHZ CHANNEL	LEGACY OFDM RATES (6,9,12,18,24,36,48,54 MBPS)	802.11n HT20 RATES (MCS 0 MCS 15)	802.11n HT40 RATES (MCS 0 MCS 15)
52		8.5	8.5	
54	(52, 56)			8.0
56		8.5	8.5	
60		8.5	8.5	
62	(60, 64)			8.0
64		8.5	8.5	
100		15.0	15.0	
102	(100, 104)			15.5
104		15.0	15.0	
108		15.0	15.0	
110				15.5
112	(108, 112)	15.0	15.0	
116		15.0	15.0	
118	(116, 120)			
120				
124				
126	(124, 128)			
128				
132				
134	(132, 136)			16.0
136		15.0	15.0	
140		15.5	15.5	
149				
151	(149, 153)			
153				
157				
159	(157, 161)			
161				
165				

Patch antenna, peak gain = 10dBi

AP622, AP6522, AP6562 EU Domain 5 GHz Yagi Antenna Model

The following is a transmit power table (EU domain) per yagi antenna in the 5 GHz band:

20 MHZ CHANNEL	40 MHZ CHANNEL	LEGACY OFDM RATES (6,9,12,18,24,36,48,54 MBPS)	802.11n HT20 RATES (MCS 0 MCS 15)	802.11n HT40 RATES (MCS 0 MCS 15)
36		8.0	8.0	
38	(36, 40)			7.5
40		8.0	8.0	
44		8.0	8.0	
46	(44, 48)			7.5
48		8.0	8.0	
52		4.0	4.0	
54	(52, 56)			3.5
56		4.0	4.0	
60		4.0	4.0	
62	(60, 64)			3.5
64		4.0	4.0	
100		10.5	10.5	
102	(100, 104)			9.5
104		10.5	10.5	
108		10.5	10.5	
110				9.5
112	(108, 112)	10.5	10.5	
116		10.5	10.5	
118	(116, 120)			
120				
124				
126	(124, 128)			
128				
132				
134	(132, 136)			9.5
136		10.5	10.5	
140		9.5	9.5	
149				
151	(149, 153)			
153				
157				
159	(157, 161)			

20 MHZ CHANNEL	40 MHZ CHANNEL	LEGACY OFDM RATES (6,9,12,18,24,36,48,54 MBPS)	802.11n HT20 RATES (MCS 0 MCS 15)	802.11n HT40 RATES (MCS 0 MCS 15)
161				
165				

Yagi antenna, peak gain = 11dBi

AP622, AP6522, AP6562 Japan Regulatory Domain 2.4 GHz Band

AP622, AP6522, AP6562 Japan Domain 2.4 GHz Internal Antenna Model

The following is a transmit power table (Japan domain) per internal antenna in the 2.4 GHz band:

20 MHZ CHANNEL	40 MHZ CHANNEL	LEGACY DSSS RATES (1, 2, 5.5, 11 MBPS)	LEGACY OFDM RATES (6,9,12,18,24,36,48,54 MBPS)	802.11n HT20 RATES (MCS 0 MCS 15)	802.11n HT40 RATES (MCS 0 MCS15)
1		17.0	16.5	17.5	
2		17.0	16.5	17.5	
3	(1, 5)	17.0	16.5	17.5	17.5
4	(2, 6)	17.0	16.5	17.5	17.5
5	(3, 7)	17.0	16.5	17.5	17.5
6	(4, 8)	17.0	16.5	17.5	17.5
7	(5, 9)	17.0	16.5	17.5	17.5
8	(6, 10)	17.0	16.5	17.5	17.5
9	(7, 11)	17.0	16.5	17.5	17.5
10	(8, 12)	17.0	16.5	17.5	17.5
11	(9, 13)	17.0	16.5	17.5	17.5
12		17.0	16.5	17.5	
13		17.0	16.5	17.5	

Internal antenna, peak gain = 3.9dBi

AP622, AP6522, AP6562 Japan Domain 2.4 GHz Dipole Antenna Model

The following is a transmit power table (Japan domain) per dipole antenna in the 2.4 GHz band:

20 MHZ CHANNEL	40 MHZ CHANNEL	LEGACY DSSS RATES (1, 2, 5.5, 11 MBPS)	LEGACY OFDM RATES (6,9,12,18,24,36,48,54 MBPS)	802.11n HT20 RATES (MCS 0 MCS 15)	802.11n HT40 RATES (MCS 0 MCS15)
1		11.0	10.5	11.5	
2		11.0	10.5	11.5	
3	(1, 5)	11.0	10.5	11.5	11.5
4	(2, 6)	11.0	10.5	11.5	11.5
5	(3, 7)	11.0	10.5	11.5	11.5
6	(4, 8)	11.0	10.5	11.5	11.5
7	(5, 9)	11.0	10.5	11.5	11.5
8	(6, 10)	11.0	10.5	11.5	11.5
9	(7, 11)	11.0	10.5	11.5	11.5
10	(8, 12)	11.0	10.5	11.5	11.5
11	(9, 13)	11.0	10.5	11.5	11.5
12		11.0	10.5	11.5	
13		11.0	10.5	11.5	

Dipole antenna, peak gain = 8.5dBi

AP622, AP6522, AP6562 Japan Domain 2.4 GHz Panel Antenna Model

The following is a transmit power table (Japan domain) per panel antenna in the 2.4 GHz band:

20 MHZ CHANNEL	40 MHZ CHANNEL	LEGACY DSSS RATES (1, 2, 5.5, 11 MBPS)	LEGACY OFDM RATES (6,9,12,18,24,36,48,54 MBPS)	802.11n HT20 RATES (MCS 0 MCS 15)	802.11n HT40 RATES (MCS 0 MCS15)
1		6.0	5.5	6.5	
2		6.0	5.5	6.5	
3	(1, 5)	6.0	5.5	6.5	6.5
4	(2, 6)	6.0	5.5	6.5	6.5
5	(3, 7)	6.0	5.5	6.5	6.5
6	(4, 8)	6.0	5.5	6.5	6.5
7	(5, 9)	6.0	5.5	6.5	6.5
8	(6, 10)	6.0	5.5	6.5	6.5
9	(7, 11)	6.0	5.5	6.5	6.5
10	(8, 12)	6.0	5.5	6.5	6.5
11	(9, 13)	6.0	5.5	6.5	6.5

20 MHZ CHANNEL	40 MHZ CHANNEL	LEGACY DSSS RATES (1, 2, 5.5, 11 MBPS)	LEGACY OFDM RATES (6,9,12,18,24,36,48,54 MBPS)	802.11n HT20 RATES (MCS 0 MCS 15)	802.11n HT40 RATES (MCS 0 MCS15)
12		6.0	5.5	6.5	
13		6.0	5.5	6.5	

Panel antenna, peak gain = 10.9dBi

AP622, AP6522, AP6562 Japan Domain 2.4 GHz Patch Antenna Model

The following is a transmit power table (Japan domain) per patch antenna in the 2.4 GHz band:

20 MHZ CHANNEL	40 MHZ CHANNEL	LEGACY DSSS RATES (1, 2, 5.5, 11 MBPS)	LEGACY OFDM RATES (6,9,12,18,24,36,48,54 MBPS)	802.11n HT20 RATES (MCS 0 MCS 15)	802.11n HT40 RATES (MCS 0 MCS15)
1		15.0	14.5	15.5	
2		15.0	14.5	15.5	
3	(1, 5)	15.0	14.5	15.5	15.5
4	(2, 6)	15.0	14.5	15.5	15.5
5	(3, 7)	15.0	14.5	15.5	15.5
6	(4, 8)	15.0	14.5	15.5	15.5
7	(5, 9)	15.0	14.5	15.5	15.5
8	(6, 10)	15.0	14.5	15.5	15.5
9	(7, 11)	15.0	14.5	15.5	15.5
10	(8, 12)	15.0	14.5	15.5	15.5
11	(9, 13)	15.0	14.5	15.5	15.5
12		15.0	14.5	15.5	
13		15.0	14.5	15.5	

Patch antenna, peak gain = 3.5dBi

AP622, AP6522, AP6562 Japan Domain 2.4 GHz Yagi Antenna Model

The following is a transmit power table (Japan domain) per yagi antenna in the 2.4 GHz band:

20 MHZ CHANNEL	40 MHZ CHANNEL	LEGACY DSSS RATES (1, 2, 5.5, 11 MBPS)	LEGACY OFDM RATES (6,9,12,18,24,36,48,54 MBPS)	802.11n HT20 RATES (MCS 0 MCS 15)	802.11n HT40 RATES (MCS 0 MCS15)
1		6.0	5.5	6.5	
2		6.0	5.5	6.5	

20 MHZ CHANNEL	40 MHZ CHANNEL	LEGACY DSSS RATES (1, 2, 5.5, 11 MBPS)	LEGACY OFDM RATES (6,9,12,18,24,36,48,54 MBPS)	802.11n HT20 RATES (MCS 0 MCS 15)	802.11n HT40 RATES (MCS 0 MCS15)
3	(1, 5)	6.0	5.5	6.5	6.5
4	(2, 6)	6.0	5.5	6.5	6.5
5	(3, 7)	6.0	5.5	6.5	6.5
6	(4, 8)	6.0	5.5	6.5	6.5
7	(5, 9)	6.0	5.5	6.5	6.5
8	(6, 10)	6.0	5.5	6.5	6.5
9	(7, 11)	6.0	5.5	6.5	6.5
10	(8, 12)	6.0	5.5	6.5	6.5
11	(9, 13)	6.0	5.5	6.5	6.5
12		6.0	5.5	6.5	
13		6.0	5.5	6.5	

Yagi antenna, peak gain = 11.1dBi

AP622, AP6522, AP6562 Japan Regulatory Domain 5 GHz Band

AP622, AP6522, AP6562 Japan Domain 5 GHz Internal Antenna Model

The following is a transmit power table (Japan domain) per internal antenna in the 5 GHz band:

20 MHZ CHANNEL	40 MHZ CHANNEL	LEGACY OFDM RATES (6,9,12,18,24,36,48,54 MBPS)	802.11n HT20 RATES (MCS 0 MCS 15)	802.11n HT40 RATES (MCS 0 MCS 15)
36		10.5	11.5	
38	(36, 40)			11.5
40		10.5	11.5	
44		10.5	11.5	
46	(44, 48)			11.5
48		10.5	11.5	
52		11.5	11.5	
54	(52, 56)			10.5
56		11.5	11.5	
60		11.5	11.5	
62	(60, 64)			10.5
64		11.5	11.5	
100		16.5	17.5	

20 MHZ CHANNEL	40 MHZ CHANNEL	LEGACY OFDM RATES (6,9,12,18,24,36,48,54 MBPS)	802.11n HT20 RATES (MCS 0 MCS 15)	802.11n HT40 RATES (MCS 0 MCS 15)
102	(100, 104)			16.5
104		16.5	17.5	
108		16.5	17.5	
110				16.5
112	(108, 112)	16.5	17.5	
116		16.5	17.5	
118	(116, 120)			
120				
124				
126	(124, 128)			
128				
132				
134	(132, 136)			16.5
136		16.5	17.5	
140		16.5	17.5	
149				
151	(149, 153)			
153				
157				
159	(157, 161)			
161				
165				

Internal antenna, peak gain = 7.5dBi

AP622, AP6522, AP6562 Japan Domain 5 GHz Dipole Omni Antenna Model

The following is a transmit power table (Japan domain) per dipole omni antenna in the 5 GHz band:

20 MHZ CHANNEL	40 MHZ CHANNEL	LEGACY OFDM RATES (6,9,12,18,24,36,48,54 MBPS)	802.11n HT20 RATES (MCS 0 MCS 15)	802.11n HT40 RATES (MCS 0 MCS 15)
36		6.5	7.5	
38	(36, 40)			7.5
40		6.5	7.5	
44		6.5	7.5	

20 MHZ CHANNEL	40 MHZ CHANNEL	LEGACY OFDM RATES (6,9,12,18,24,36,48,54 MBPS)	802.11n HT20 RATES (MCS 0 MCS 15)	802.11n HT40 RATES (MCS 0 MCS 15)
46	(44, 48)			7.5
48		6.5	7.5	
52		7.5	7.5	
54	(52, 56)			6.5
56		7.5	7.5	
60		7.5	7.5	
62	(60, 64)			6.5
64		7.5	7.5	
100		12.5	13.5	
102	(100, 104)			12.5
104		12.5	13.5	
108		12.5	13.5	
110				12.5
112	(108, 112)	12.5	13.5	
116		12.5	13.5	
118	(116, 120)			
120				
124				
126	(124, 128)			
128				
132				
134	(132, 136)			12.5
136		12.5	13.5	
140		12.5	13.5	
149				
151	(149, 153)			
153				
157				
159	(157, 161)			
161				
165				

Dipole omni antenna, peak gain = 9dBi

AP622, AP6522, AP6562 Japan Domain 5 GHz Panel Antenna Model

The following is a transmit power table (Japan domain) per panel antenna in the 5 GHz band:

20 MHZ CHANNEL	40 MHZ CHANNEL	LEGACY OFDM RATES (6,9,12,18,24,36,48,54 MBPS)	802.11n HT20 RATES (MCS 0 MCS 15)	802.11n HT40 RATES (MCS 0 MCS 15)
36		3.5	4.5	
38	(36, 40)			4.5
40		3.5	4.5	
44		3.5	4.5	
46	(44, 48)			4.5
48		3.5	4.5	
52		4.5	4.5	
54	(52, 56)			3.5
56		4.5	4.5	
60		4.5	4.5	
62	(60, 64)			3.5
64		4.5	4.5	
100		9.5	10.5	
102	(100, 104)			9.5
104		9.5	10.5	
108		9.5	10.5	
110				9.5
112	(108, 112)	9.5	10.5	
116		9.5	10.5	
118	(116, 120)			
120				
124				
126	(124, 128)			
128				
132				
134	(132, 136)			9.5
136		9.5	10.5	
140		9.5	10.5	
149				
151	(149, 153)			
153				
157				

20 MHZ CHANNEL	40 MHZ CHANNEL	LEGACY OFDM RATES (6,9,12,18,24,36,48,54 MBPS)	802.11n HT20 RATES (MCS 0 MCS 15)	802.11n HT40 RATES (MCS 0 MCS 15)
159	(157, 161)			
161				
165				

Panel antenna, peak gain = 12.5dBi

AP622, AP6522, AP6562 Japan Domain 5 GHz Patch Antenna Model

The following is a transmit power table (Japan domain) per patch antenna in the 5 GHz band:

20 MHZ CHANNEL	40 MHZ CHANNEL	LEGACY OFDM RATES (6,9,12,18,24,36,48,54 MBPS)	802.11n HT20 RATES (MCS 0 MCS 15)	802.11n HT40 RATES (MCS 0 MCS 15)
36		10.5	11.5	
38	(36, 40)			11.5
40		10.5	11.5	
44		10.5	11.5	
46	(44, 48)			11.5
48		10.5	11.5	
52		11.5	11.5	
54	(52, 56)			10.5
56		11.5	11.5	
60		11.5	11.5	
62	(60, 64)			10.5
64		11.5	11.5	
100		16.5	17.5	
102	(100, 104)			16.5
104		16.5	17.5	
108		16.5	17.5	
110				16.5
112	(108, 112)	16.5	17.5	
116		16.5	17.5	
118	(116, 120)			
120				
124				
126	(124, 128)			

20 MHZ CHANNEL	40 MHZ CHANNEL	LEGACY OFDM RATES (6,9,12,18,24,36,48,54 MBPS)	802.11n HT20 RATES (MCS 0 MCS 15)	802.11n HT40 RATES (MCS 0 MCS 15)
128				
132				
134	(132, 136)			16.5
136		16.5	17.5	
140		16.5	17.5	
149				
151	(149, 153)			
153				
157				
159	(157, 161)			
161				
165				

Patch antenna, peak gain = 10dBi

AP622, AP6522, AP6562 Japan Domain 5 GHz Yagi Antenna Model

The following is a transmit power table (Japan domain) per yagi antenna in the 5 GHz band:

20 MHZ CHANNEL	40 MHZ CHANNEL	LEGACY OFDM RATES (6,9,12,18,24,36,48,54 MBPS)	802.11n HT20 RATES (MCS 0 MCS 15)	802.11n HT40 RATES (MCS 0 MCS 15)
36		4.5	5.5	
38	(36, 40)			5.5
40		4.5	5.5	
44		4.5	5.5	
46	(44, 48)			5.5
48		4.5	5.5	
52		5.5	5.5	
54	(52, 56)			4.5
56		5.5	5.5	
60		5.5	5.5	
62	(60, 64)			4.5
64		5.5	5.5	
100		10.5	11.5	
102	(100, 104)			10.5

20 MHZ CHANNEL	40 MHZ CHANNEL	LEGACY OFDM RATES (6,9,12,18,24,36,48,54 MBPS)	802.11n HT20 RATES (MCS 0 MCS 15)	802.11n HT40 RATES (MCS 0 MCS 15)
104		10.5	11.5	
108		10.5	11.5	
110				10.5
112	(108, 112)	10.5	11.5	
116		10.5	11.5	
118	(116, 120)			
120				
124				
126	(124, 128)			
128				
132				
134	(132, 136)			10.5
136		10.5	11.5	
140		10.5	11.5	
149				
151	(149, 153)			
153				
157				
159	(157, 161)			
161				
165				

Yagi antenna, peak gain = 11dBi

16 AP7161 Regulatory Domains

AP7161 US Regulatory Domain 2.4 GHz Band
 AP7161 US Regulatory Domain 4.9 GHz Band
 AP7161 US Regulatory Domain 5 GHz Band
 AP7161 EU Regulatory Domain 2.4 GHz Band
 AP7161 EU Regulatory Domain 5 GHz Band
 AP7161 Japan Regulatory Domain 2.4 GHz Band
 AP7161 Japan Regulatory Domain 5 GHz Band

AP7161 US Regulatory Domain 2.4 GHz Band

AP7161 US Domain 2.4 GHz Dipole Omni Antenna Maximum Conducted Transmit Power Settings

The following is a transmit power table (US domain) per dipole omni antenna in the 2.4 GHz band:

20 MHZ CHANNEL	40 MHZ CHANNEL	LEGACY DSSS RATES (1, 2, 5.5, 11 MBPS)	LEGACY OFDM RATES (6,9,12,18,24,36,48,54 MBPS)	802.11n HT20 RATES (MCS 0 MCS 15)	802.11n HT40 RATES (MCS 0 MCS15)
1		18.5	16.5	16.5	
2		19.0	16.5	16.5	
3	(1, 5)	19.0	16.5	16.5	15.5
4	(2, 6)	19.0	16.5	16.5	15.5
5	(3, 7)	19.0	16.5	16.5	15.5
6	(4, 8)	19.0	16.5	16.5	15.0
7	(5, 9)	19.0	16.5	18.0	15.0
8	(6, 10)	19.0	16.5	18.0	15.0
9	(7, 11)	19.0	18.0	18.0	15.0
10		19.0	18.0	18.0	
11		18.0	18.0	18.0	

Internal antenna, peak gain = 8.0dBi

AP7161 US Regulatory Domain 4.9 GHz Band

AP7161 US Domain 4.9 GHz Dipole Omni Antenna Model - 3Tx Transmitter Configuration

The following is a transmit power table (US domain) per dipole omni antenna in the 4.9 GHz band (3Tx):

20 MHZ CHANNEL	40 MHZ CHANNEL	LEGACY DSSS RATES (1, 2, 5.5, 11 MBPS)	LEGACY OFDM RATES (6,9,12,18,24,36,48,54 MBPS)	802.11n HT20 RATES (MCS 0 MCS 15)	802.11n HT40 RATES (MCS 0 MCS15)
21			9.5	9.5	
25			9.5	9.5	

Internal antenna, peak gain = 10.5dBi

AP7161 US Domain 4.9 GHz Dipole Omni Antenna Model - 1Tx Transmitter Configuration

The following is a transmit power table (US domain) per dipole omni antenna in the 4.9 GHz band (1Tx):

20 MHZ CHANNEL	40 MHZ CHANNEL	LEGACY DSSS RATES (1, 2, 5.5, 11 MBPS)	LEGACY OFDM RATES (6,9,12,18,24,36,48,54 MBPS)	802.11n HT20 RATES (MCS 0 MCS 15)	802.11n HT40 RATES (MCS 0 MCS15)
21			18.5	18.5	
25			19.0	19.0	

Internal antenna, peak gain = 10.5dBi

AP7161 US Regulatory Domain 5 GHz Band

AP7161 US Domain 5 GHz Dipole Omni Antenna Model

The following is a transmit power table (US domain) per dipole omni antenna in the 5 GHz band:

20 MHZ CHANNEL	40 MHZ CHANNEL	LEGACY OFDM RATES (6,9,12,18,24,36,48,54 MBPS)	802.11n HT20 RATES (MCS 0 MCS 15)	802.11n HT40 RATES (MCS 0 MCS 15)
36				
38	(36, 40)			
40				
44				
46	(44, 48)			
48				
52		9.5	10.0	
54	(52, 56)			120

20 MHZ CHANNEL	40 MHZ CHANNEL	LEGACY OFDM RATES (6,9,12,18,24,36,48,54 MBPS)	802.11n HT20 RATES (MCS 0 MCS 15)	802.11n HT40 RATES (MCS 0 MCS 15)
56		9.5	10.0	
60		9.0	9.5	
62	(60, 64)			12.0
64		9.5	10.0	
100		7.5	8.0	
102	(100, 104)			10.5
104		9.5	10.0	
108		9.5	10.0	
110				10.5
112	(108, 112)	9.5	10.0	
116		9.5	10.0	
118	(116, 120)			
120		9.5	10.0	
124		11.0	11.0	
126	(124, 128)			12.5
128		11.0	11.0	
132		11.0	11.0	
134	(132, 136)			12.5
136		11.0	11.0	
140		11.0	11.0	
149		19.0	19.0	
151	(149, 153)			15.5
153		19.0	19.0	
157		17.0	16.5	
159	(157, 161)			17.0
161		17.0	17.5	
165		17.0	17.5	

Yagi antenna, peak gain = 10.5dBi

AP7161 EU Regulatory Domain 2.4 GHz Band

AP7161 EU Domain 2.4 GHz Dipole Omni Antenna Model

The following is a transmit power table (EU domain) per dipole omni antenna in the 2.4 GHz band:

20 MHZ CHANNEL	40 MHZ CHANNEL	LEGACY DSSS RATES (1, 2, 5.5, 11 MBPS)	LEGACY OFDM RATES (6,9,12,18,24,36,48,54 MBPS)	802.11n HT20 RATES (MCS 0 MCS 15)	802.11n HT40 RATES (MCS 0 MCS15)
1		6.0	6.0	5.0	
2		6.0	6.0	5.0	
3	(1, 5)	6.0	6.0	5.0	7.0
4	(2, 6)	6.0	5.5	5.0	7.0
5	(3, 7)	6.0	5.5	5.0	7.0
6	(4, 8)	6.0	5.5	5.0	7.0
7	(5, 9)	6.0	5.5	5.0	7.0
8	(6, 10)	6.0	5.5	5.0	7.0
9	(7, 11)	6.0	5.0	5.0	7.0
10		6.0	5.0	5.0	
11		6.0	5.0	5.0	
12					
13					

Internal antenna, peak gain = 8.0dBi

AP7161 EU Regulatory Domain 5 GHz Band

AP7161 EU Domain 5 GHz Dipole Omni Antenna Model

The following is a transmit power table (EU domain) per dipole omni antenna in the 5 GHz band:

20 MHZ CHANNEL	40 MHZ CHANNEL	LEGACY OFDM RATES (6,9,12,18,24,36,48,54 MBPS)	802.11n HT20 RATES (MCS 0 MCS 15)	802.11n HT40 RATES (MCS 0 MCS 15)
36		8.5	8.5	
38	(36, 40)			9.0
40		8.5	8.5	
44		8.5	8.5	
46	(44, 48)			9.0
48		8.5	8.5	
52		7.0	7.0	
54	(52, 56)			7.5
56		7.0	7.0	
60		7.0	7.0	
62	(60, 64)			7.5

20 MHZ CHANNEL	40 MHZ CHANNEL	LEGACY OFDM RATES (6,9,12,18,24,36,48,54 MBPS)	802.11n HT20 RATES (MCS 0 MCS 15)	802.11n HT40 RATES (MCS 0 MCS 15)
64		7.0	7.0	
100		14.5	14.5	
102	(100, 104)			16.0
104		14.5	14.5	
108		14.5	14.5	
110				16.0
112	(108, 112)	14.5	14.5	
116		14.5	14.5	
118	(116, 120)			16.0
120		14.5	14.5	
124		14.5	14.5	
126	(124, 128)			16.0
128		14.5	14.5	
132		14.5	14.5	
134	(132, 136)			16.0
136		14.5	14.5	
140		14.5	14.5	
149		10.5	10.5	
151	(149, 153)			
153		10.5	10.5	
157		10.5	10.5	
159	(157, 161)			
161		10.0	10.0	
165		10.0	10.0	

Internal antenna, peak gain = 10.5dBi

AP7161 Japan Regulatory Domain 2.4 GHz Band

AP7161 Japan Domain 2.4 GHz Dipole Omni Antenna Model

The following is a transmit power table (Japan domain) per dipole omni antenna in the 2.4 GHz band:

20 MHZ CHANNEL	40 MHZ CHANNEL	LEGACY DSSS RATES (1, 2, 5.5, 11 MBPS)	LEGACY OFDM RATES (6,9,12,18,24,36,48,54 MBPS)	802.11n HT20 RATES (MCS 0 MCS 15)	802.11n HT40 RATES (MCS 0 MCS15)
1		16.5	13.0	13.5	
2		16.5	13.0	13.5	
3	(1, 5)	16.5	13.0	13.5	13.5
4	(2, 6)	16.5	13.0	13.5	13.5
5	(3, 7)	16.5	13.0	13.5	13.5
6	(4, 8)	16.5	13.0	13.5	13.5
7	(5, 9)	16.5	13.0	13.5	13.5
8	(6, 10)	16.5	13.0	13.5	13.5
9	(7, 11)	16.5	13.0	13.5	13.5
10	(8, 12)	16.5	13.0	13.5	
11	(9, 13)	16.5	13.0	13.5	
12		16.5	13.0	13.5	
13		16.5	13.0	13.5	

Internal antenna, peak gain = 8.0dBi

AP7161 Japan Regulatory Domain 5 GHz Band

AP7161 Japan Domain 5 GHz Dipole Omni Antenna Model

The following is a transmit power table (Japan domain) per dipole omni antenna in the 5 GHz band:

20 MHZ CHANNEL	40 MHZ CHANNEL	LEGACY OFDM RATES (6,9,12,18,24,36,48,54 MBPS)	802.11n HT20 RATES (MCS 0 MCS 15)	802.11n HT40 RATES (MCS 0 MCS 15)
36		10.0	10.5	
38	(36, 40)			11.0
40		10.0	10.5	
44		10.0	10.5	
46	(44, 48)			11.0
48		10.0	10.5	
52		10.0	10.5	
54	(52, 56)			10.5
56		10.0	10.5	
60		10.0	10.5	
62	(60, 64)			10.5

20 MHZ CHANNEL	40 MHZ CHANNEL	LEGACY OFDM RATES (6,9,12,18,24,36,48,54 MBPS)	802.11n HT20 RATES (MCS 0 MCS 15)	802.11n HT40 RATES (MCS 0 MCS 15)
64		10.0	10.5	
100		15.0	15.5	
102	(100, 104)			16.0
104		15.0	15.5	
108		15.0	15.5	
110				16.0
112	(108, 112)	15.0	15.5	
116		15.0	15.5	
118	(116, 120)			16.0
120		15.0	15.5	
124		15.0	15.5	
126	(124, 128)			16.0
128		15.0	15.5	
132		15.0	15.5	
134	(132, 136)			16.0
136		15.0	15.5	
140		15.0	15.5	
149				
151	(149, 153)			
153				
157				
159	(157, 161)			
161				
165				

Internal antenna, peak gain = 10.5dBi

17 AP8132 Regulatory Domains

AP8132 US Regulatory Domain 2.4 GHz Band
 AP8132 US Regulatory Domain 5 GHz Band
 AP8132 EU Regulatory Domain 2.4 GHz Band
 AP8132 EU Regulatory Domain 5 GHz Band
 AP8132 Japan Regulatory Domain 2.4 GHz Band
 AP8132 Japan Regulatory Domain 5 GHz Band

AP8132 US Regulatory Domain 2.4 GHz Band

AP8132 US Domain 2.4 GHz External Dipole Antenna Maximum Conducted Transmit Power Settings

The following is a transmit power table (US domain) per external dipole antenna in the 2.4 GHz band:

20 MHZ CHANNEL	40 MHZ CHANNEL	LEGACY DSSS RATES (1, 2, 5.5, 11 MBPS)	LEGACY OFDM RATES (6,9,12,18,24,36,48,54 MBPS)	802.11n HT20 RATES (MCS 0 MCS 15)	802.11n HT40 RATES (MCS 0 MCS15)
1		17.0	17.0	16.0	
2		17.0	17.0	17.0	
3	(1, 5)	18.0	21.0	21.0	13.0
4	(2, 6)	18.0	21.0	21.0	13.0
5	(3, 7)	18.0	21.0	21.0	19.0
6	(4, 8)	18.0	21.0	21.0	19.0
7	(5, 9)	18.0	21.0	21.0	19.0
8	(6, 10)	18.0	21.0	21.0	10.0
9	(7, 11)	18.0	21.0	21.0	10.0
10		18.0	17.0	17.0	
11		18.0	17.0	17.0	

External dipole antenna, peak gain = 10.5dBi

AP8132 US Domain 2.4 GHz External Panel Antenna Maximum Conducted Transmit Power Settings

The following is a transmit power table (US domain) per external panel antenna in the 2.4 GHz band:

20 MHZ CHANNEL	40 MHZ CHANNEL	LEGACY DSSS RATES (1, 2, 5.5, 11 MBPS)	LEGACY OFDM RATES (6,9,12,18,24,36,48,54 MBPS)	802.11n HT20 RATES (MCS 0 MCS 15)	802.11n HT40 RATES (MCS 0 MCS15)
1		12.0	13.0	13.0	
2		17.0	17.0	17.0	
3	(1, 5)	17.0	17.0	17.0	10.0
4	(2, 6)	17.0	17.0	17.0	10.0
5	(3, 7)	17.0	17.0	17.0	14.0
6	(4, 8)	17.0	17.0	17.0	14.0
7	(5, 9)	17.0	17.0	17.0	14.0
8	(6, 10)	17.0	17.0	17.0	6.0
9	(7, 11)	17.0	17.0	17.0	6.0
10		17.0	17.0	17.0	
11		16.0	15.0	15.0	

External Panel antenna, peak gain = 15dBi

AP8132 US Domain 2.4 GHz External Yagi Antenna Maximum Conducted Transmit Power Settings

The following is a transmit power table (US domain) per external yagi antenna in the 2.4 GHz band:

20 MHZ CHANNEL	40 MHZ CHANNEL	LEGACY DSSS RATES (1, 2, 5.5, 11 MBPS)	LEGACY OFDM RATES (6,9,12,18,24,36,48,54 MBPS)	802.11n HT20 RATES (MCS 0 MCS 15)	802.11n HT40 RATES (MCS 0 MCS15)
1		8.0	9.0	9.0	
2		8.0	13.0	13.0	
3	(1, 5)	17.0	13.0	13.0	9.0
4	(2, 6)	17.0	13.0	13.0	9.0
5	(3, 7)	17.0	13.0	13.0	12.0
6	(4, 8)	17.0	13.0	13.0	12.0
7	(5, 9)	17.0	13.0	13.0	12.0
8	(6, 10)	17.0	13.0	13.0	6.0
9	(7, 11)	17.0	13.0	13.0	6.0
10		6.0	13.0	13.0	
11		6.0	13.0	13.0	

External yagi antenna, peak gain = 14.5dBi

AP8132 US Domain 2.4 GHz External Patch Antenna Maximum Conducted Transmit Power Settings

The following is a transmit power table (US domain) per external patch antenna in the 2.4 GHz band:

20 MHZ CHANNEL	40 MHZ CHANNEL	LEGACY DSSS RATES (1, 2, 5.5, 11 MBPS)	LEGACY OFDM RATES (6,9,12,18,24,36,48,54 MBPS)	802.11n HT20 RATES (MCS 0 MCS 15)	802.11n HT40 RATES (MCS 0 MCS15)
1		20.0	17.0	17.0	
2		23.0	23.0	23.0	
3	(1, 5)	23.0	23.0	23.0	13.0
4	(2, 6)	23.0	23.0	23.0	13.0
5	(3, 7)	23.0	23.0	23.0	18.0
6	(4, 8)	23.0	23.0	23.0	18.0
7	(5, 9)	23.0	23.0	23.0	18.0
8	(6, 10)	23.0	23.0	23.0	14.0
9	(7, 11)	23.0	23.0	23.0	14.0
10		23.0	23.0	23.0	
11		19.0	17.0	17.0	

External patch antenna, peak gain = 4dBi

AP8132 US Domain 2.4 GHz Facade Antenna Maximum Conducted Transmit Power Settings

The following is a transmit power table (US domain) per internal facade antenna in the 2.4 GHz band:

20 MHZ CHANNEL	40 MHZ CHANNEL	LEGACY DSSS RATES (1, 2, 5.5, 11 MBPS)	LEGACY OFDM RATES (6,9,12,18,24,36,48,54 MBPS)	802.11n HT20 RATES (MCS 0 MCS 15)	802.11n HT40 RATES (MCS 0 MCS15)
1		20.0	18.0	18.0	
2		23.0	23.0	23.0	
3	(1, 5)	23.0	23.0	23.0	14.0
4	(2, 6)	23.0	23.0	23.0	18.0
5	(3, 7)	23.0	23.0	23.0	18.0
6	(4, 8)	23.0	23.0	23.0	18.0
7	(5, 9)	23.0	23.0	23.0	18.0
8	(6, 10)	23.0	23.0	23.0	18.0
9	(7, 11)	23.0	23.0	23.0	14.0
10		23.0	23.0	23.0	
11		20.0	19.0	19.0	

Facade antenna, peak gain = 3.5dBi

AP8132 US Regulatory Domain 5 GHz Band

AP8132 US Domain 5 GHz External Dipole Antenna Model

The following is a transmit power table (US domain) per external dipole antenna in the 5 GHz band:

20 MHZ CHANNEL	40 MHZ CHANNEL	LEGACY OFDM RATES (6,9,12,18,24,36,48,54 MBPS)	802.11n HT20 RATES (MCS 0 MCS 15)	802.11n HT40 RATES (MCS 0 MCS 15)
36		8.0	8.0	
38	(36, 40)	8.0	8.0	8.0
40		8.0	8.0	
44		8.0	8.0	
46	(44, 48)	8.0	8.0	9.0
48		8.0	8.0	
52		15.0	16.0	
54	(52, 56)	15.0	15.0	16.0
56		15.0	15.0	
60		15.0	15.0	
62	(60, 64)	15.0	15.0	15.0
64		15.0	15.0	
100		15.0	15.0	
102	(100, 104)	15.0	15.0	11.5
104		15.0	15.0	
108		15.0	15.0	
110		15.0	15.0	15.0
112		15.0	15.0	
116		15.0	15.0	
118	(116, 120)	15.0	15.0	15.0
120		15.0	15.0	
124		15.0	15.0	
126	(124, 128)	15.0	15.0	16.0
128		15.0	15.0	
132		15.0	15.0	
134	(132, 136)	15.0	15.0	16.0
136		15.0	15.0	

20 MHZ CHANNEL	40 MHZ CHANNEL	LEGACY OFDM RATES (6,9,12,18,24,36,48,54 MBPS)	802.11n HT20 RATES (MCS 0 MCS 15)	802.11n HT40 RATES (MCS 0 MCS 15)
140		14.0	14.0	
149		20.0	20.0	
151	(149, 153)	20.0	20.0	20.0
153		20.0	20.0	
157		20.0	20.0	
159	(157, 161)	20.0	20.0	20.0
161		20.0	20.0	
165		20.0	20.0	

External dipole antenna, peak gain = 10.5dBi

AP8132 US Domain 5 GHz External Panel Antenna Model

The following is a transmit power table (US domain) per external panel antenna in the 5 GHz band:

20 MHZ CHANNEL	40 MHZ CHANNEL	LEGACY OFDM RATES (6,9,12,18,24,36,48,54 MBPS)	802.11n HT20 RATES (MCS 0 MCS 15)	802.11n HT40 RATES (MCS 0 MCS 15)
36		4.0	4.0	
38	(36, 40)	4.0	4.0	4.0
40		4.0	4.0	
44		4.0	4.0	
46	(44, 48)	4.0	4.0	4.0
48		4.0	4.0	
52		4.0	4.0	
54	(52, 56)	4.0	4.0	4.0
56		4.0	4.0	
60		4.0	4.0	
62	(60, 64)	4.0	4.0	4.0
64		4.0	4.0	
100		4.0	4.0	
102	(100, 104)	4.0	4.0	4.0
104		4.0	4.0	
108		4.0	4.0	
110		4.0	4.0	6.0
112		4.0	4.0	

20 MHZ CHANNEL	40 MHZ CHANNEL	LEGACY OFDM RATES (6,9,12,18,24,36,48,54 MBPS)	802.11n HT20 RATES (MCS 0 MCS 15)	802.11n HT40 RATES (MCS 0 MCS 15)
116		4.0	4.0	
118	(116, 120)	4.0	4.0	4.0
120		4.0	4.0	
124		4.0	4.0	
126	(124, 128)	4.0	4.0	4.0
128		4.0	4.0	
132		4.0	4.0	
134	(132, 136)	4.0	4.0	4.0
136		4.0	4.0	
140		4.0	4.0	
149		20.0	20.0	
151	(149, 153)	20.0	20.0	20.0
153		20.0	20.0	
157		20.0	20.0	
159	(157, 161)	20.0	20.0	20.0
161		20.0	20.0	
165		20.0	20.0	

External panel antenna, peak gain = 12dBi

AP8132 US Domain 5 GHz External Yagi Antenna Model

The following is a transmit power table (US domain) per external yagi antenna in the 5 GHz band:

20 MHZ CHANNEL	40 MHZ CHANNEL	LEGACY OFDM RATES (6,9,12,18,24,36,48,54 MBPS)	802.11n HT20 RATES (MCS 0 MCS 15)	802.11n HT40 RATES (MCS 0 MCS 15)
36		8.0	8.0	
38	(36, 40)	8.0	8.0	8.0
40		8.0	8.0	
44		8.0	8.0	
46	(44, 48)	8.0	8.0	8.0
48		8.0	8.0	
52		12.0	12.0	
54	(52, 56)	3.0	3.5	11.5
56		3.0	3.5	

20 MHZ CHANNEL	40 MHZ CHANNEL	LEGACY OFDM RATES (6,9,12,18,24,36,48,54 MBPS)	802.11n HT20 RATES (MCS 0 MCS 15)	802.11n HT40 RATES (MCS 0 MCS 15)
60		3.0	3.5	
62	(60, 64)	3.0	3.5	9.0
64		3.0	3.5	
100		6.5	7.0	
102	(100, 104)	6.5	7.0	7.0
104		15.0	15.0	
108		15.0	15.0	
110		15.0	15.0	7.5
112	(108, 112)	15.0	15.0	
116		15.0	15.0	
118	(116, 120)	15.0	15.0	6.5
120		15.0	15.0	
124		15.0	15.0	
126	(124, 128)	15.0	15.0	6.5
128		15.0	15.0	
132		15.0	15.0	
134	(132, 136)	15.0	15.0	10.0
136		4.0	3.5	
140		4.0	3.5	
149		20.0	20.0	
151	(149, 153)	20.0	20.0	20.0
153		20.0	20.0	
157		20.0	20.0	
159	(157, 161)	20.0	20.0	20.0
161		20.0	20.0	
165		20.0	20.0	

Panel antenna, peak gain = 10.5dBi

AP8132 US Domain 5 GHz External Patch Antenna Model

The following is a transmit power table (US domain) per external patch antenna in the 5 GHz band:

20 MHZ CHANNEL	40 MHZ CHANNEL	LEGACY OFDM RATES (6,9,12,18,24,36,48,54 MBPS)	802.11n HT20 RATES (MCS 0 MCS 15)	802.11n HT40 RATES (MCS 0 MCS 15)
36		15.0	15.0	
38	(36, 40)	15.0	15.0	13.0
40		15.0	15.0	
44		15.0	15.0	
46	(44, 48)	15.0	15.0	13.0
48		15.0	15.0	
52		18.0	18.0	
54	(52, 56)	18.0	18.0	20.0
56		18.0	18.0	
60		18.0	18.0	
62	(60, 64)	18.0	18.0	17.5
64		18.0	18.0	
100		17.0	17.0	
102	(100, 104)	17.0	17.0	14.5
104		20.0	20.0	
108		20.0	20.0	
110		20.0	20.0	20.0
112	(108, 112)	20.0	20.0	
116		20.0	20.0	
118	(116, 120)	20.0	20.0	19.5
120		20.0	20.0	
124		20.0	20.0	
126	(124, 128)	20.0	20.0	20.0
128		20.0	20.0	
132		20.0	20.0	
134	(132, 136)	20.0	20.0	19.5
136		17.0	17.0	
140		17.0	17.0	
149		20.0	20.0	
151	(149, 153)	20.0	20.0	20.0
153		20.0	20.0	
157		20.0	20.0	
159	(157, 161)	20.0	20.0	20.0

20 MHZ CHANNEL	40 MHZ CHANNEL	LEGACY OFDM RATES (6,9,12,18,24,36,48,54 MBPS)	802.11n HT20 RATES (MCS 0 MCS 15)	802.11n HT40 RATES (MCS 0 MCS 15)
161		20.0	20.0	
165		20.0	20.0	

External patch antenna, peak gain = 3.8dBi

AP8132 US Domain 5 GHz Facade Antenna Model

The following is a transmit power table (US domain) per external facade antenna in the 5 GHz band:

20 MHZ CHANNEL	40 MHZ CHANNEL	LEGACY OFDM RATES (6,9,12,18,24,36,48,54 MBPS)	802.11n HT20 RATES (MCS 0 MCS 15)	802.11n HT40 RATES (MCS 0 MCS 15)
36		14.0	14.0	
38	(36, 40)	14.0	14.0	14.0
40		14.0	14.0	
44		14.0	14.0	
46	(44, 48)	14.0	14.0	14.0
48		14.0	14.0	
52		20.0	20.0	
54	(52, 56)	20.0	20.0	18.0
56		20.0	20.0	
60		20.0	20.0	
62	(60, 64)	20.0	20.0	18.0
64		20.0	20.0	
100		18.0	18.0	
102	(100, 104)	17.0	17.0	20.0
104		20.0	20.0	
108		20.0	20.0	
110		20.0	20.0	18.5
112	(108, 112)	20.0	20.0	
116		20.0	20.0	
118	(116, 120)	20.0	20.0	15.0
120		20.0	20.0	
124		20.0	20.0	
126	(124, 128)	20.0	20.0	20.0
128		20.0	20.0	

20 MHZ CHANNEL	40 MHZ CHANNEL	LEGACY OFDM RATES (6,9,12,18,24,36,48,54 MBPS)	802.11n HT20 RATES (MCS 0 MCS 15)	802.11n HT40 RATES (MCS 0 MCS 15)
132		20.0	20.0	
134	(132, 136)	20.0	20.0	20.0
136		20.0	20.0	
140		17.0	17.0	
149		20.0	20.0	
151	(149, 153)	20.0	20.0	20.0
153		20.0	20.0	
157		20.0	20.0	
159	(157, 161)	20.0	20.0	20.0
161		20.0	20.0	
165		20.0	20.0	

Facade antenna, peak gain = 4.0dBi

AP8132 EU Regulatory Domain 2.4 GHz Band

AP8132 EU Domain 2.4 GHz External Dipole Antenna Model

The following is a transmit power table (EU domain) per external dipole antenna in the 2.4 GHz band:

20 MHZ CHANNEL	40 MHZ CHANNEL	LEGACY DSSS RATES (1, 2, 5.5, 11 MBPS)	LEGACY OFDM RATES (6,9,12,18,24,36,48,54 MBPS)	802.11n HT20 RATES (MCS 0 MCS 15)	802.11n HT40 RATES (MCS 0 MCS15)
1		4.5	4.5	4.5	
2		4.5	4.5	4.5	
3	(1, 5)	4.5	4.5	4.5	4.5
4	(2, 6)	4.5	4.5	4.5	4.5
5	(3, 7)	4.5	4.5	4.5	4.5
6	(4, 8)	4.5	4.5	4.5	4.5
7	(5, 9)	4.5	4.5	4.5	4.5
8	(6, 10)	4.5	4.5	4.5	4.5
9	(7, 11)	4.5	4.5	4.5	4.5
10	(8, 12)	4.5	4.5	4.5	4.5
11	(9, 13)	4.5	4.5	4.5	4.5
12		4.5	4.5	4.5	

20 MHZ CHANNEL	40 MHZ CHANNEL	LEGACY DSSS RATES (1, 2, 5.5, 11 MBPS)	LEGACY OFDM RATES (6,9,12,18,24,36,48,54 MBPS)	802.11n HT20 RATES (MCS 0 MCS 15)	802.11n HT40 RATES (MCS 0 MCS15)
13		4.5	4.5	4.5	
14					

External dipole antenna, peak gain = 10.5dBi

AP8132 EU Domain 2.4 GHz External Panel Antenna Model

The following is a transmit power table (EU domain) per external panel antenna in the 2.4 GHz band:

20 MHZ CHANNEL	40 MHZ CHANNEL	LEGACY DSSS RATES (1, 2, 5.5, 11 MBPS)	LEGACY OFDM RATES (6,9,12,18,24,36,48,54 MBPS)	802.11n HT20 RATES (MCS 0 MCS 15)	802.11n HT40 RATES (MCS 0 MCS15)
1		7.0	7.0	7.0	
2		7.0	7.0	7.0	
3	(1, 5)	7.0	7.0	7.0	7.0
4	(2, 6)	7.0	7.0	7.0	7.0
5	(3, 7)	7.0	7.0	7.0	7.0
6	(4, 8)	7.0	7.0	7.0	7.0
7	(5, 9)	7.0	7.0	7.0	7.0
8	(6, 10)	7.0	7.0	7.0	7.0
9	(7, 11)	7.0	7.0	7.0	7.0
10	(8, 12)	7.0	7.0	7.0	7.0
11	(9, 13)	7.0	7.0	7.0	7.0
12		7.0	7.0	7.0	
13		7.0	7.0	7.0	
14					

External panel antenna, peak gain = 8dBi

AP8132 EU Domain 2.4 GHz External Patch Antenna Model

The following is a transmit power table (EU domain) per external patch antenna in the 2.4 GHz band:

20 MHZ CHANNEL	40 MHZ CHANNEL	LEGACY DSSS RATES (1, 2, 5.5, 11 MBPS)	LEGACY OFDM RATES (6,9,12,18,24,36,48,54 MBPS)	802.11n HT20 RATES (MCS 0 MCS 15)	802.11n HT40 RATES (MCS 0 MCS15)
1		11.0	11.0	11.0	
2		11.0	11.0	11.0	
3	(1, 5)	11.0	11.0	11.0	11.0
4	(2, 6)	11.0	11.0	11.0	11.0
5	(3, 7)	11.0	11.0	11.0	11.0
6	(4, 8)	11.0	11.0	11.0	11.0
7	(5, 9)	11.0	11.0	11.0	11.0
8	(6, 10)	11.0	11.0	11.0	11.0
9	(7, 11)	11.0	11.0	11.0	11.0
10		11.0	11.0	11.0	
11		11.0	11.0	11.0	
12					
13					
14					

External patch antenna, peak gain = 4dBi

AP8132 EU Domain 2.4 GHz Facade Antenna Model

The following is a transmit power table (EU domain) per internal facade antenna in the 2.4 GHz band:

20 MHZ CHANNEL	40 MHZ CHANNEL	LEGACY DSSS RATES (1, 2, 5.5, 11 MBPS)	LEGACY OFDM RATES (6,9,12,18,24,36,48,54 MBPS)	802.11n HT20 RATES (MCS 0 MCS 15)	802.11n HT40 RATES (MCS 0 MCS15)
1		11.5	11.5	11.5	
2		11.5	11.5	11.5	
3	(1, 5)	11.5	11.5	11.5	11.5
4	(2, 6)	11.5	11.5	11.5	11.5
5	(3, 7)	11.5	11.5	11.5	11.5
6	(4, 8)	11.5	11.5	11.5	11.5
7	(5, 9)	11.5	11.5	11.5	11.5
8	(6, 10)	11.5	11.5	11.5	11.5
9	(7, 11)	11.5	11.5	11.5	11.5
10		11.5	11.5	11.5	
11		11.5	11.5	11.5	

20 MHZ CHANNEL	40 MHZ CHANNEL	LEGACY DSSS RATES (1, 2, 5.5, 11 MBPS)	LEGACY OFDM RATES (6,9,12,18,24,36,48,54 MBPS)	802.11n HT20 RATES (MCS 0 MCS 15)	802.11n HT40 RATES (MCS 0 MCS15)
12					
13					
14					

Facade antenna, peak gain = 3.5dBi

AP8132 EU Regulatory Domain 5 GHz Band

AP8132 EU Domain 5 GHz External Dipole Antenna Model

The following is a transmit power table (EU domain) per external dipole antenna in the 5 GHz band:

20 MHZ CHANNEL	40 MHZ CHANNEL	LEGACY OFDM RATES (6,9,12,18,24,36,48,54 MBPS)	802.11n HT20 RATES (MCS 0 MCS 15)	802.11n HT40 RATES (MCS 0 MCS 15)
36		7.5	7.5	
38	(36, 40)	7.5	7.5	7.5
40		7.5	7.5	
44		7.5	7.5	
46	(44, 48)	7.5	7.5	7.5
48		7.5	7.5	
52		7.5	7.5	
54	(52, 56)	7.5	7.5	7.5
56		7.5	7.5	
60		7.5	7.5	
62	(60, 64)	7.5	7.5	7.5
64		7.5	7.5	
100		14.5	14.5	
102	(100, 104)	14.5	14.5	14.5
104		14.5	14.5	
108		14.5	14.5	
110		14.5	14.5	14.5
112	(108, 112)	14.5	14.5	
116		14.5	14.5	
118	(116, 120)	14.5	14.5	14.5
120		14.5	14.5	

20 MHZ CHANNEL	40 MHZ CHANNEL	LEGACY OFDM RATES (6,9,12,18,24,36,48,54 MBPS)	802.11n HT20 RATES (MCS 0 MCS 15)	802.11n HT40 RATES (MCS 0 MCS 15)
124		14.5	14.5	
126	(124, 128)	14.5	14.5	14.5
128		14.5	14.5	
132		14.5	14.5	
134	(132, 136)	14.5	14.5	14.5
136		14.5	14.5	
140		14.5	14.5	
149				
151	(149, 153)			
153				
157				
159	(157, 161)			
161				
165				

External dipole antenna, peak gain = 10.5dBi

AP8132 EU Domain 5 GHz External Panel Antenna Model

The following is a transmit power table (EU domain) per external panel antenna in the 5 GHz band:

20 MHZ CHANNEL	40 MHZ CHANNEL	LEGACY OFDM RATES (6,9,12,18,24,36,48,54 MBPS)	802.11n HT20 RATES (MCS 0 MCS 15)	802.11n HT40 RATES (MCS 0 MCS 15)
36		4.0	4.0	
38	(36, 40)	4.0	4.0	4.0
40		4.0	4.0	
44		4.0	4.0	
46	(44, 48)	4.0	4.0	4.0
48		4.0	4.0	
52		4.0	4.0	
54	(52, 56)	4.0	4.0	4.0
56		4.0	4.0	
60		4.0	4.0	
62	(60, 64)	4.0	4.0	4.0
64		4.0	4.0	

20 MHZ CHANNEL	40 MHZ CHANNEL	LEGACY OFDM RATES (6,9,12,18,24,36,48,54 MBPS)	802.11n HT20 RATES (MCS 0 MCS 15)	802.11n HT40 RATES (MCS 0 MCS 15)
100		11.0	11.0	
102	(100, 104)	11.0	11.0	11.0
104		11.0	11.0	
108		11.0	11.0	
110		11.0	11.0	11.0
112	(108, 112)	11.0	11.0	
116		11.0	11.0	
118	(116, 120)	11.0	11.0	11.0
120		11.0	11.0	
124		11.0	11.0	
126	(124, 128)	11.0	11.0	11.0
128		11.0	11.0	
132		11.0	11.0	
134	(132, 136)	11.0	11.0	11.0
136		11.0	11.0	
140		11.0	11.0	
149				
151	(149, 153)			
153				
157				
159	(157, 161)			
161				
165				

External panel antenna, peak gain = 14dBi

AP8132 EU Domain 5 GHz External Yagi Antenna Model

The following is a transmit power table (EU domain) per external yagi antenna in the 5 GHz band:

20 MHZ CHANNEL	40 MHZ CHANNEL	LEGACY OFDM RATES (6,9,12,18,24,36,48,54 MBPS)	802.11n HT20 RATES (MCS 0 MCS 15)	802.11n HT40 RATES (MCS 0 MCS 15)
36		7.5	6.0	
38	(36, 40)	7.5	7.5	7.5
40		7.5	7.5	

20 MHZ CHANNEL	40 MHZ CHANNEL	LEGACY OFDM RATES (6,9,12,18,24,36,48,54 MBPS)	802.11n HT20 RATES (MCS 0 MCS 15)	802.11n HT40 RATES (MCS 0 MCS 15)
44		7.5	7.5	
46	(44, 48)	7.5	7.5	7.5
48		7.5	7.5	
52		7.5	7.5	
54	(52, 56)	7.5	7.5	7.5
56		7.5	7.5	
60		7.5	7.5	
62	(60, 64)	7.5	7.5	7.5
64		7.5	7.5	
100		14.5	14.5	
102	(100, 104)	14.5	14.5	14.5
104		14.5	14.5	
108		14.5	14.5	
110		14.5	14.5	14.5
112	(108, 112)	14.5	14.5	
116		14.5	14.5	
118	(116, 120)	14.5	14.5	14.5
120		14.5	14.5	
124		14.5	14.5	
126	(124, 128)	14.5	14.5	14.5
128		14.5	14.5	
132		14.5	14.5	
134	(132, 136)	14.5	14.5	14.5
136		14.5	14.5	
140		14.5	14.5	
149				
151	(149, 153)			
153				
157				
159	(157, 161)			
161				
165				

External yagi antenna, peak gain = 10.5dBi

AP8132 EU Domain 5 GHz External Patch Antenna Model

The following is a transmit power table (EU domain) per external patch antenna in the 5 GHz band:

20 MHZ CHANNEL	40 MHZ CHANNEL	LEGACY OFDM RATES (6,9,12,18,24,36,48,54 MBPS)	802.11n HT20 RATES (MCS 0 MCS 15)	802.11n HT40 RATES (MCS 0 MCS 15)
36		14.5	14.5	
38	(36, 40)	14.5	14.5	14.5
40		14.5	14.5	
44		14.5	14.5	
46	(44, 48)	14.5	14.5	14.5
48		14.5	14.5	
52		14.5	14.5	
54	(52, 56)	14.5	14.5	14.5
56		14.5	14.5	
60		14.5	14.5	
62	(60, 64)	14.5	14.5	14.5
64		14.5	14.5	
100		20.0	20.0	
102	(100, 104)	20.0	20.0	20.0
104		20.0	20.0	
108		20.0	20.0	
110		20.0	20.0	20.0
112	(108, 112)	20.0	20.0	
116		20.0	20.0	
118	(116, 120)	20.0	20.0	20.0
120		20.0	20.0	
124		20.0	20.0	
126	(124, 128)	20.0	20.0	20.0
128		20.0	20.0	
132		20.0	20.0	
134	(132, 136)	20.0	20.0	20.0
136		20.0	20.0	
140		20.0	20.0	
149				
151	(149, 153)			
153				
157				

20 MHZ CHANNEL	40 MHZ CHANNEL	LEGACY OFDM RATES (6,9,12,18,24,36,48,54 MBPS)	802.11n HT20 RATES (MCS 0 MCS 15)	802.11n HT40 RATES (MCS 0 MCS 15)
159	(157, 161)			
161				
165				

External patch antenna, peak gain = 3.8dBi

AP8132 EU Domain 5 GHz Facade Antenna Model

The following is a transmit power table (EU domain) per external facade antenna in the 5 GHz band:

20 MHZ CHANNEL	40 MHZ CHANNEL	LEGACY OFDM RATES (6,9,12,18,24,36,48,54 MBPS)	802.11n HT20 RATES (MCS 0 MCS 15)	802.11n HT40 RATES (MCS 0 MCS 15)
36		14.0	14.0	
38	(36, 40)	14.0	14.0	14.0
40		14.0	14.0	
44		14.0	14.0	
46	(44, 48)	14.0	14.0	14.0
48		14.0	14.0	
52		14.0	14.0	
54	(52, 56)	14.0	14.0	14.0
56		14.0	14.0	
60		14.0	14.0	
62	(60, 64)	14.0	14.0	14.0
64		14.0	14.0	
100		20.0	20.0	
102	(100, 104)	20.0	20.0	20.0
104		20.0	20.0	
108		20.0	20.0	
110		20.0	20.0	20.0
112	(108, 112)	20.0	20.0	
116		20.0	20.0	
118	(116, 120)	20.0	20.0	20.0
120		20.0	20.0	
124		20.0	20.0	
126	(124, 128)	20.0	20.0	20.0

20 MHZ CHANNEL	40 MHZ CHANNEL	LEGACY OFDM RATES (6,9,12,18,24,36,48,54 MBPS)	802.11n HT20 RATES (MCS 0 MCS 15)	802.11n HT40 RATES (MCS 0 MCS 15)
128		20.0	20.0	
132		20.0	20.0	
134	(132, 136)	20.0	20.0	20.0
136		20.0	20.0	
140		20.0	20.0	
149				
151	(149, 153)			
153				
157				
159	(157, 161)			
161				
165				

Facade antenna, peak gain = 4dBi

AP8132 Japan Regulatory Domain 2.4 GHz Band

AP8132 Japan Domain 2.4 GHz External Dipole Antenna Model

The following is a transmit power table (Japan domain) per external dipole antenna in the 2.4 GHz band:

20 MHZ CHANNEL	40 MHZ CHANNEL	LEGACY DSSS RATES (1, 2, 5.5, 11 MBPS)	LEGACY OFDM RATES (6,9,12,18,24,36,48,54 MBPS)	802.11n HT20 RATES (MCS 0 MCS 15)	802.11n HT40 RATES (MCS 0 MCS 15)
1		8.0	9.0	9.0	
2		8.0	9.0	9.0	
3	(1, 5)	8.0	9.0	9.0	9.0
4	(2, 6)	8.0	9.0	9.0	9.0
5	(3, 7)	8.0	9.0	9.0	9.0
6	(4, 8)	8.0	9.0	9.0	9.0
7	(5, 9)	8.0	9.0	9.0	9.0
8	(6, 10)	8.0	9.0	9.0	9.0
9	(7, 11)	8.0	9.0	9.0	9.0
10	(8, 12)	8.0	9.0	9.0	9.0
11	(9, 13)	8.0	9.0	9.0	9.0

20 MHZ CHANNEL	40 MHZ CHANNEL	LEGACY DSSS RATES (1, 2, 5.5, 11 MBPS)	LEGACY OFDM RATES (6,9,12,18,24,36,48,54 MBPS)	802.11n HT20 RATES (MCS 0 MCS 15)	802.11n HT40 RATES (MCS 0 MCS15)
12		8.0	9.0	9.0	
13		8.0	9.0	9.0	
14					

External dipole antenna, peak gain = 10.5dBi

AP8132 Japan Domain 2.4 GHz External Panel Antenna Model

The following is a transmit power table (Japan domain) per external panel antenna in the 2.4 GHz band:

20 MHZ CHANNEL	40 MHZ CHANNEL	LEGACY DSSS RATES (1, 2, 5.5, 11 MBPS)	LEGACY OFDM RATES (6,9,12,18,24,36,48,54 MBPS)	802.11n HT20 RATES (MCS 0 MCS 15)	802.11n HT40 RATES (MCS 0 MCS15)
1		13.0	14.0	14.0	
2		13.0	14.0	14.0	
3	(1, 5)	13.0	14.0	14.0	14.0
4	(2, 6)	13.0	14.0	14.0	14.0
5	(3, 7)	13.0	14.0	14.0	14.0
6	(4, 8)	13.0	14.0	14.0	14.0
7	(5, 9)	13.0	14.0	14.0	14.0
8	(6, 10)	13.0	14.0	14.0	14.0
9	(7, 11)	13.0	14.0	14.0	14.0
10	(8, 12)	13.0	14.0	14.0	14.0
11	(9, 13)	13.0	14.0	14.0	14.0
12		13.0	14.0	14.0	
13		13.0	14.0	14.0	
14					

External panel antenna, peak gain = 15dBi

AP8132 Japan Domain 2.4 GHz External Yagi Antenna Model

The following is a transmit power table (Japan domain) per external yagi antenna in the 2.4 GHz band:

20 MHZ CHANNEL	40 MHZ CHANNEL	LEGACY DSSS RATES (1, 2, 5.5, 11 MBPS)	LEGACY OFDM RATES (6,9,12,18,24,36,48,54 MBPS)	802.11n HT20 RATES (MCS 0 MCS 15)	802.11n HT40 RATES (MCS 0 MCS15)
1		14.0	15.0	15.0	
2		14.0	15.0	15.0	
3	(1, 5)	14.0	15.0	15.0	15.0
4	(2, 6)	14.0	15.0	15.0	15.0
5	(3, 7)	14.0	15.0	15.0	15.0
6	(4, 8)	14.0	15.0	15.0	15.0
7	(5, 9)	14.0	15.0	15.0	15.0
8	(6, 10)	14.0	15.0	15.0	15.0
9	(7, 11)	14.0	15.0	15.0	15.0
10		14.0	15.0	15.0	15.0
11		14.0	15.0	15.0	15.0
12		14.0	15.0	15.0	
13		14.0	15.0	15.0	
14					

External patch antenna, peak gain = 14.5dBi

AP8132 Japan Domain 2.4 GHz External Patch Antenna Model

The following is a transmit power table (Japan domain) per external patch antenna in the 2.4 GHz band:

20 MHZ CHANNEL	40 MHZ CHANNEL	LEGACY DSSS RATES (1, 2, 5.5, 11 MBPS)	LEGACY OFDM RATES (6,9,12,18,24,36,48,54 MBPS)	802.11n HT20 RATES (MCS 0 MCS 15)	802.11n HT40 RATES (MCS 0 MCS15)
1		14.0	15.0	15.0	
2		14.0	15.0	15.0	
3	(1, 5)	14.0	15.0	15.0	15.0
4	(2, 6)	14.0	15.0	15.0	15.0
5	(3, 7)	14.0	15.0	15.0	15.0
6	(4, 8)	14.0	15.0	15.0	15.0
7	(5, 9)	14.0	15.0	15.0	15.0
8	(6, 10)	14.0	15.0	15.0	15.0
9	(7, 11)	14.0	15.0	15.0	15.0
10		14.0	15.0	15.0	
11		14.0	15.0	15.0	

20 MHZ CHANNEL	40 MHZ CHANNEL	LEGACY DSSS RATES (1, 2, 5.5, 11 MBPS)	LEGACY OFDM RATES (6,9,12,18,24,36,48,54 MBPS)	802.11n HT20 RATES (MCS 0 MCS 15)	802.11n HT40 RATES (MCS 0 MCS15)
12					
13					
14					

External patch antenna, peak gain = 4dBi

AP8132 Japan Domain 2.4 GHz Internal Facade Antenna Model

The following is a transmit power table (Japan domain) per internal facade antenna in the 2.4 GHz band:

20 MHZ CHANNEL	40 MHZ CHANNEL	LEGACY DSSS RATES (1, 2, 5.5, 11 MBPS)	LEGACY OFDM RATES (6,9,12,18,24,36,48,54 MBPS)	802.11n HT20 RATES (MCS 0 MCS 15)	802.11n HT40 RATES (MCS 0 MCS15)
1		15.0	15.0	15.0	
2		15.0	15.0	15.0	
3	(1, 5)	15.0	15.0	15.0	15.0
4	(2, 6)	15.0	15.0	15.0	15.0
5	(3, 7)	15.0	15.0	15.0	15.0
6	(4, 8)	15.0	15.0	15.0	15.0
7	(5, 9)	15.0	15.0	15.0	15.0
8	(6, 10)	15.0	15.0	15.0	15.0
9	(7, 11)	15.0	15.0	15.0	15.0
10		15.0	15.0	15.0	
11		15.0	15.0	15.0	
12					
13					
14					

Facade antenna, peak gain = 3.4 dBi

AP8132 Japan Regulatory Domain 5 GHz Band

AP8132 Japan Domain 5 GHz External Dipole Antenna Model

The following is a transmit power table (Japan domain) per external dipole antenna in the 5 GHz band:

20 MHZ CHANNEL	40 MHZ CHANNEL	LEGACY OFDM RATES (6,9,12,18,24,36,48,54 MBPS)	802.11n HT20 RATES (MCS 0 MCS 15)	802.11n HT40 RATES (MCS 0 MCS 15)
36		7.0	7.0	
38	(36, 40)	7.0	7.0	7.0
40		7.0	7.0	
44		7.0	7.0	
46	(44, 48)	7.0	7.0	7.0
48		7.0	7.0	
52		7.0	7.0	
54	(52, 56)	7.0	7.0	7.0
56		7.0	7.0	
60		7.0	7.0	
62	(60, 64)	7.0	7.0	7.0
64		7.0	7.0	
100		14.0	14.0	
102	(100, 104)	14.0	14.0	14.0
104		14.0	14.0	
108		14.0	14.0	
110		14.0	14.0	14.0
112	(108, 112)	14.0	14.0	
116		14.0	14.0	
118	(116, 120)	14.0	14.0	14.0
120		14.0	14.0	
124		14.0	14.0	
126	(124, 128)	14.0	14.0	14.0
128		14.0	14.0	
132		14.0	14.0	
134	(132, 136)	14.0	14.0	14.0
136		14.0	14.0	
140		14.0	14.0	
149				
151	(149, 153)			
153				
157				
159	(157, 161)			

20 MHZ CHANNEL	40 MHZ CHANNEL	LEGACY OFDM RATES (6,9,12,18,24,36,48,54 MBPS)	802.11n HT20 RATES (MCS 0 MCS 15)	802.11n HT40 RATES (MCS 0 MCS 15)
161				
165				

External dipole antenna, peak gain = 10.5dBi

AP8132 Japan Domain 5 GHz External Panel Antenna Model

The following is a transmit power table (Japan domain) per external panel antenna in the 5 GHz band:

20 MHZ CHANNEL	40 MHZ CHANNEL	LEGACY OFDM RATES (6,9,12,18,24,36,48,54 MBPS)	802.11n HT20 RATES (MCS 0 MCS 15)	802.11n HT40 RATES (MCS 0 MCS 15)
36		3.0	3.0	
38	(36, 40)	3.0	3.0	3.0
40		3.0	3.0	
44		3.0	3.0	
46	(44, 48)	3.0	3.0	3.0
48		3.0	3.0	
52		3.0	3.0	
54	(52, 56)	3.0	3.0	3.0
56		3.0	3.0	
60		3.0	3.0	
62	(60, 64)	3.0	3.0	3.0
64		3.0	3.0	
100		10.0	10.0	
102	(100, 104)	10.0	10.0	10.0
104		10.0	10.0	
108		10.0	10.0	
110		10.0	10.0	10.0
112	(108, 112)	10.0	10.0	
116		10.0	10.0	
118	(116, 120)	10.0	10.0	10.0
120		10.0	10.0	
124		10.0	10.0	
126	(124, 128)	10.0	10.0	10.0
128		10.0	10.0	

20 MHZ CHANNEL	40 MHZ CHANNEL	LEGACY OFDM RATES (6,9,12,18,24,36,48,54 MBPS)	802.11n HT20 RATES (MCS 0 MCS 15)	802.11n HT40 RATES (MCS 0 MCS 15)
132		10.0	10.0	
134	(132, 136)	10.0	10.0	10.0
136		10.0	10.0	
140		10.0	10.0	
149				
151	(149, 153)			
153				
157				
159	(157, 161)			
161				
165				

External panel antenna, peak gain = 14dBi

AP8132 Japan Domain 5 GHz External Yagi Antenna Model

The following is a transmit power table (Japan domain) per external yagi antenna in the 5 GHz band:

20 MHZ CHANNEL	40 MHZ CHANNEL	LEGACY OFDM RATES (6,9,12,18,24,36,48,54 MBPS)	802.11n HT20 RATES (MCS 0 MCS 15)	802.11n HT40 RATES (MCS 0 MCS 15)
36		7.0	7.0	
38	(36, 40)	7.0	7.0	7.0
40		7.0	7.0	
44		7.0	7.0	
46	(44, 48)	7.0	7.0	7.0
48		7.0	7.0	
52		7.0	7.0	
54	(52, 56)	7.0	7.0	7.0
56		7.0	7.0	
60		7.0	7.0	
62	(60, 64)	7.0	7.0	7.0
64		7.0	7.0	
100		14.0	14.0	
102	(100, 104)	14.0	14.0	14.0
104		14.0	14.0	

20 MHZ CHANNEL	40 MHZ CHANNEL	LEGACY OFDM RATES (6,9,12,18,24,36,48,54 MBPS)	802.11n HT20 RATES (MCS 0 MCS 15)	802.11n HT40 RATES (MCS 0 MCS 15)
108		14.0	14.0	
110		14.0	14.0	14.0
112	(108, 112)	14.0	14.0	
116		14.0	14.0	
118	(116, 120)	14.0	14.0	14.0
120		14.0	14.0	
124		14.0	14.0	
126	(124, 128)	14.0	14.0	14.0
128		14.0	14.0	
132		14.0	14.0	
134	(132, 136)	14.0	14.0	14.0
136		14.0	14.0	
140		14.0	14.0	
149				
151	(149, 153)			
153				
157				
159	(157, 161)			
161				
165				

External yagi antenna, peak gain = 10.5dBi

AP8132 Japan Domain 5 GHz External Patch Antenna Model

The following is a transmit power table (Japan domain) per external patch antenna in the 5 GHz band:

20 MHZ CHANNEL	40 MHZ CHANNEL	LEGACY OFDM RATES (6,9,12,18,24,36,48,54 MBPS)	802.11n HT20 RATES (MCS 0 MCS 15)	802.11n HT40 RATES (MCS 0 MCS 15)
36		13.5	13.5	
38	(36, 40)	13.5	13.5	13.5
40		13.5	13.5	
44		13.5	13.5	
46	(44, 48)	13.5	13.5	13.5
48		13.5	13.5	

20 MHZ CHANNEL	40 MHZ CHANNEL	LEGACY OFDM RATES (6,9,12,18,24,36,48,54 MBPS)	802.11n HT20 RATES (MCS 0 MCS 15)	802.11n HT40 RATES (MCS 0 MCS 15)
52		13.5	13.5	
54	(52, 56)	13.5	13.5	13.5
56		13.5	13.5	
60		13.5	13.5	
62	(60, 64)	13.5	13.5	13.5
64		13.5	13.5	
100		20.0	20.0	
102	(100, 104)	20.0	20.0	20.0
104		20.0	20.0	
108		20.0	20.0	
110		20.0	20.0	20.0
112	(108, 112)	20.0	20.0	
116		20.0	20.0	
118	(116, 120)	20.0	20.0	20.0
120		20.0	20.0	
124		20.0	20.0	
126	(124, 128)	20.0	20.0	20.0
128		20.0	20.0	
132		20.0	20.0	
134	(132, 136)	20.0	20.0	20.0
136		20.0	20.0	
140		20.0	20.0	
149				
151	(149, 153)			
153				
157				
159	(157, 161)			
161				
165				

External patch antenna, peak gain = 3.8dBi

AP8132 Japan Domain 5 GHz Facade Antenna Model

The following is a transmit power table (Japan domain) per external facade antenna in the 5 GHz band:

20 MHZ CHANNEL	40 MHZ CHANNEL	LEGACY OFDM RATES (6,9,12,18,24,36,48,54 MBPS)	802.11n HT20 RATES (MCS 0 MCS 15)	802.11n HT40 RATES (MCS 0 MCS 15)
36		13.5	13.5	
38	(36, 40)	13.5	13.5	13.5
40		13.5	13.5	
44		13.5	13.5	
46	(44, 48)	13.5	13.5	13.5
48		13.5	13.5	
52		13.5	13.5	
54	(52, 56)	13.5	13.5	13.5
56		13.5	13.5	
60		13.5	13.5	
62	(60, 64)	13.5	13.5	13.5
64		13.5	13.5	
100		20.0	20.0	
102	(100, 104)	20.0	20.0	20.0
104		20.0	20.0	
108		20.0	20.0	
110		20.0	20.0	20.0
112	(108, 112)	20.0	20.0	
116		20.0	20.0	
118	(116, 120)	20.0	20.0	20.0
120		20.0	20.0	
124		20.0	20.0	
126	(124, 128)	20.0	20.0	20.0
128		20.0	20.0	
132		20.0	20.0	
134	(132, 136)	20.0	20.0	20.0
136		20.0	20.0	
140		20.0	20.0	
149				
151	(149, 153)			
153				
157				
159	(157, 161)			

20 MHZ CHANNEL	40 MHZ CHANNEL	LEGACY OFDM RATES (6,9,12,18,24,36,48,54 MBPS)	802.11n HT20 RATES (MCS 0 MCS 15)	802.11n HT40 RATES (MCS 0 MCS 15)
161				
165				

Facade antenna, peak gain = 4dBi



18 AP8122 Regulatory Domains

AP8122 US Regulatory Domain 2.4 GHz Band
 AP8122 US Regulatory Domain 5 GHz Band
 AP8122 EU Regulatory Domain 2.4 GHz Band
 AP8122 EU Regulatory Domain 5 GHz Band

AP8122 US Regulatory Domain 2.4 GHz Band

AP8122 US Domain 2.4 GHz Internal Antenna Maximum Conducted Transmit Power Settings

The following is a transmit power table (US domain) per internal antenna in the 2.4 GHz band:

20 MHZ CHANNEL	40 MHZ CHANNEL	LEGACY DSSS RATES (1, 2, 5.5, 11 MBPS)	LEGACY OFDM RATES (6,9,12,18,24,36,48,54 MBPS)	802.11n HT20 RATES (MCS 0 MCS 15)	802.11n HT40 RATES (MCS 0 MCS 15)
1		20.0	21.0	16.0	
2		22.0	23.0	18.0	
3	(1, 5)	22.0	23.0	18.0	11.0
4	(2, 6)	22.0	23.0	18.0	11.0
5	(3, 7)	22.0	23.0	18.0	15.0
6	(4, 8)	22.0	23.0	18.0	15.0
7	(5, 9)	22.0	23.0	18.0	15.0
8	(6, 10)	22.0	23.0	18.0	11.0
9	(7, 11)	22.0	23.0	18.0	11.0
10		22.0	23.0	18.0	
11		20.0	20.0	15.0	

Internal antenna, peak gain = 4.4dBi

AP8122 US Regulatory Domain 5 GHz Band

AP8122 US Domain 5 GHz Internal Antenna Model

The following is a transmit power table (US domain) per internal antenna in the 5 GHz band:

20 MHZ CHANNEL	40 MHZ CHANNEL	LEGACY OFDM RATES (6,9,12,18,24,36,48,54 MBPS)	802.11n HT20 RATES (MCS 0 MCS 15)	802.11n HT40 RATES (MCS 0 MCS 15)
36		17.0	11.5	
38	(36, 40)	17.0	11.5	5.5
40		17.0	11.5	
44		17.0	11.5	
46	(44, 48)	17.0	11.5	9.0
48		17.0	11.5	
52		20.0	20.0	
54	(52, 56)	20.0	20.0	16.0
56		20.0	20.0	
60		20.0	20.0	
62	(60, 64)	20.0	20.0	8.5
64		20.0	20.0	
100		17.0	12.5	
102	(100, 104)	17.0	12.5	7.0
104		20.0	20.0	
108		20.0	20.0	
110		20.0	20.0	18.0
112		20.0	20.0	
116		18.0	13.5	
118	(116, 120)	20.0	20.0	18.0
120		20.0	20.0	
124		20.0	20.0	
126	(124, 128)	20.0	20.0	18.0
128		20.0	20.0	
132		20.0	20.0	
134	(132, 136)	20.0	20.0	9.0
136		20.0	20.0	
140		20.0	20.0	
142		17.0	12.0	9.0
144		17.0	12.0	
149		20.0	20.0	
151	(149, 153)	20.0	20.0	20.0
153		20.0	20.0	
155		20.0	20.0	

20 MHZ CHANNEL	40 MHZ CHANNEL	LEGACY OFDM RATES (6,9,12,18,24,36,48,54 MBPS)	802.11n HT20 RATES (MCS 0 MCS 15)	802.11n HT40 RATES (MCS 0 MCS 15)
157		20.0	17.0	
159	(157, 161)	20.0	17.0	17.0
161		20.0	17.0	
165		20.0	15.5	

Internal antenna, peak gain = 4.7dBi

AP8122 EU Regulatory Domain 2.4 GHz Band

AP8122 EU Domain 2.4 GHz Internal Antenna Model

The following is a transmit power table (EU domain) per internal antenna in the 2.4 GHz band:

20 MHZ CHANNEL	40 MHZ CHANNEL	LEGACY DSSS RATES (1, 2, 5.5, 11 MBPS)	LEGACY OFDM RATES (6,9,12,18,24,36,48,54 MBPS)	802.11n HT20 RATES (MCS 0 MCS 15)	802.11n HT40 RATES (MCS 0 MCS 15)
1		10.0	10.0	10.0	
2		10.0	10.0	10.0	
3	(1, 5)	10.0	10.0	10.0	10.0
4	(2, 6)	10.0	10.0	10.0	10.0
5	(3, 7)	10.0	10.0	10.0	10.0
6	(4, 8)	10.0	10.0	10.0	10.0
7	(5, 9)	10.0	10.0	10.0	10.0
8	(6, 10)	10.0	10.0	10.0	10.0
9	(7, 11)	10.0	10.0	10.0	10.0
10	(8, 12)	10.0	10.0	10.0	10.0
11	(9, 13)	10.0	10.0	10.0	10.0
12		10.0	10.0	10.0	
13		10.0	10.0	10.0	
14					

Internal antenna, peak gain = 4.4dBi

AP8122 EU Regulatory Domain 5 GHz Band

AP8122 EU Domain 5 GHz Internal Antenna Model

The following is a transmit power table (EU domain) per internal antenna in the 5 GHz band:

20 MHZ CHANNEL	40 MHZ CHANNEL	LEGACY OFDM RATES (6,9,12,18,24,36,48,54 MBPS)	802.11n HT20 RATES (MCS 0 MCS 15)	802.11n HT40 RATES (MCS 0 MCS 15)
36		13.0	13.0	
38	(36, 40)	13.0	13.0	13.0
40		13.0	13.0	
44		13.0	13.0	
46	(44, 48)	13.0	13.0	13.0
48		13.0	13.0	
52		13.0	13.0	
54	(52, 56)	13.0	13.0	13.0
56		13.0	13.0	
60		13.0	13.0	
62	(60, 64)	13.0	13.0	13.0
64		13.0	13.0	
100		20.0	20.0	
102	(100, 104)	20.0	20.0	20.0
104		20.0	20.0	
108		20.0	20.0	
110	(108, 112)	20.0	20.0	20.0
112		20.0	20.0	
116		20.0	20.0	
118	(116, 120)	20.0	20.0	20.0
120		20.0	20.0	
122		20.0	20.0	
124		20.0	20.0	
126	(124, 128)	20.0	20.0	20.0
128		20.0	20.0	
132		20.0	20.0	
134	(132, 136)	20.0	20.0	20.0
136		20.0	20.0	
138		20.0	20.0	
140		20.0	20.0	
142		20.0	20.0	
144		20.0	20.0	

20 MHZ CHANNEL	40 MHZ CHANNEL	LEGACY OFDM RATES (6,9,12,18,24,36,48,54 MBPS)	802.11n HT20 RATES (MCS 0 MCS 15)	802.11n HT40 RATES (MCS 0 MCS 15)
149				
151	(149, 153)			
153				
157				
159	(157, 161)			
161				
165				

Internal antenna, peak gain = 4.7dBi



19 AP8163 Regulatory Domains

AP8163 US Regulatory Domain 2.4 GHz Band
 AP8163 US Regulatory Domain 5 GHz Band
 AP8163 EU Regulatory Domain 2.4 GHz Band
 AP8163 EU Regulatory Domain 5 GHz Band

AP8163 US Regulatory Domain 2.4 GHz Band

AP8163 US Domain 2.4 GHz External Dipole Antenna Maximum Conducted Transmit Power Settings

The following is an AP8163 transmit power table (US domain) per external dipole antenna in the 2.4 GHz band:

20 MHZ CHANNEL	40 MHZ CHANNEL	LEGACY DSSS RATES (1, 2, 5.5, 11 MBPS)	LEGACY OFDM RATES (6,9,12,18,24,36,48,54 MBPS)	802.11n HT20 RATES (MCS 0 MCS 15)	802.11n HT40 RATES (MCS 0 MCS15)
1		17.0	17.0	16.0	
2		17.0	17.0	17.0	
3	(1, 5)	18.0	21.0	21.0	13.0
4	(2, 6)	18.0	21.0	21.0	13.0
5	(3, 7)	18.0	21.0	21.0	19.0
6	(4, 8)	18.0	21.0	21.0	19.0
7	(5, 9)	18.0	21.0	21.0	19.0
8	(6, 10)	18.0	21.0	21.0	10.0
9	(7, 11)	18.0	21.0	21.0	10.0
10		18.0	17.0	17.0	
11		18.0	17.0	17.0	

External dipole antenna, peak gain = 10.5dBi

AP8163 US Domain 2.4 GHz External Panel Antenna Maximum Conducted Transmit Power Settings

The following is an AP8163 transmit power table (US domain) per external panel antenna in the 2.4 GHz band:

20 MHZ CHANNEL	40 MHZ CHANNEL	LEGACY DSSS RATES (1, 2, 5.5, 11 MBPS)	LEGACY OFDM RATES (6,9,12,18,24,36,48,54 MBPS)	802.11n HT20 RATES (MCS 0 MCS 15)	802.11n HT40 RATES (MCS 0 MCS15)
1		12.0	13.0	13.0	
2		17.0	17.0	17.0	
3	(1, 5)	17.0	17.0	17.0	10.0
4	(2, 6)	17.0	17.0	17.0	10.0
5	(3, 7)	17.0	17.0	17.0	14.0
6	(4, 8)	17.0	17.0	17.0	14.0
7	(5, 9)	17.0	17.0	17.0	14.0
8	(6, 10)	17.0	17.0	17.0	6.0
9	(7, 11)	17.0	17.0	17.0	6.0
10		17.0	17.0	17.0	
11		16.0	15.0	15.0	

External panel antenna, peak gain = 15dBi

AP8163 US Domain 2.4 GHz External AP8163-USB Radio Maximum Conducted Transmit Power Settings

The following is an AP8163 transmit power table (US domain) per USB 3rd radio (2TX mode) in the 2.4 GHz band:

20 MHZ CHANNEL	40 MHZ CHANNEL	LEGACY DSSS RATES (1, 2, 5.5, 11 MBPS)	LEGACY OFDM RATES (6,9,12,18,24,36,48,54 MBPS)	802.11n HT20 RATES (MCS 0 MCS 15)	802.11n HT40 RATES (MCS 0 MCS15)
1		20.0	13.0	13.0	
2		20.0	13.0	13.0	
3	(1, 5)	20.0	16.0	16.0	15.0
4	(2, 6)	20.0	16.0	16.0	15.0
5	(3, 7)	20.0	16.0	16.0	14.0
6	(4, 8)	20.0	16.0	16.0	14.0
7	(5, 9)	20.0	16.0	16.0	14.0
8	(6, 10)	20.0	16.0	16.0	14.0
9	(7, 11)	20.0	16.0	16.0	14.0
10		20.0	18.0	18.0	
11		20.0	18.0	18.0	

External AP8163-USB radio , peak gain = 5dBi

AP8163 US Domain 2.4 GHz Dual-Polarized Antenna Maximum Conducted Transmit Power Settings

The following is an AP8163 transmit power table (US domain) per dual-polarized antenna in the 2.4 GHz band:

20 MHZ CHANNEL	40 MHZ CHANNEL	LEGACY DSSS RATES (1, 2, 5.5, 11 MBPS)	LEGACY OFDM RATES (6,9,12,18,24,36,48,54 MBPS)	802.11n HT20 RATES (MCS 0 MCS 15)	802.11n HT40 RATES (MCS 0 MCS15)
1		15.0	13.0	13.0	
2		16.0	19.0	19.0	
3	(1, 5)	16.0	19.0	19.0	11.0
4	(2, 6)	16.0	19.0	19.0	15.0
5	(3, 7)	16.0	19.0	19.0	15.0
6	(4, 8)	16.0	19.0	19.0	15.0
7	(5, 9)	16.0	19.0	19.0	15.0
8	(6, 10)	16.0	19.0	19.0	15.0
9	(7, 11)	16.0	19.0	19.0	8.0
10		16.0	19.0	19.0	
11		15.0	14.0	14.0	

Dual-polarized antenna, peak gain = 9.5dBi

AP8163 US Regulatory Domain 5 GHz Band

AP8163 US Domain 5 GHz External Dipole Antenna Model

The following is an AP8163 transmit power table (US domain) per external dipole antenna in the 5 GHz band:

20 MHZ CHANNEL	40 MHZ CHANNEL	LEGACY OFDM RATES (6,9,12,18,24,36,48,54 MBPS)	802.11n HT20 RATES (MCS 0 MCS 15)	802.11n HT40 RATES (MCS 0 MCS 15)
36		8.0	8.0	
38	(36, 40)	8.0	8.0	8.0
40		8.0	8.0	
44		8.0	8.0	
46	(44, 48)	8.0	8.0	9.0
48		8.0	8.0	
52		15.0	16.0	
54	(52, 56)	15.0	15.0	16.0

20 MHZ CHANNEL	40 MHZ CHANNEL	LEGACY OFDM RATES (6,9,12,18,24,36,48,54 MBPS)	802.11n HT20 RATES (MCS 0 MCS 15)	802.11n HT40 RATES (MCS 0 MCS 15)
56		15.0	15.0	
60		15.0	15.0	
62	(60, 64)	15.0	15.0	15.0
64		15.0	15.0	
100		15.0	15.0	
102	(100, 104)	15.0	15.0	11.5
104		15.0	15.0	
108		15.0	15.0	
110		15.0	15.0	15.0
112		15.0	15.0	
116		15.0	15.0	
118	(116, 120)	15.0	15.0	15.0
120		15.0	15.0	
124		15.0	15.0	
126	(124, 128)	15.0	15.0	16.0
128		15.0	15.0	
132		15.0	15.0	
134	(132, 136)	15.0	15.0	16.0
136		15.0	15.0	
140		14.0	14.0	
149		20.0	20.0	
151	(149, 153)	20.0	20.0	20.0
153		20.0	20.0	
157		20.0	20.0	
159	(157, 161)	20.0	20.0	20.0
161		20.0	20.0	
165		20.0	20.0	

External dipole antenna, peak gain = 10.5dBi

AP8163 US Domain 5 GHz External Panel Antenna Model

The following is an AP8163 transmit power table (US domain) per external panel antenna in the 5 GHz band:

20 MHZ CHANNEL	40 MHZ CHANNEL	LEGACY OFDM RATES (6,9,12,18,24,36,48,54 MBPS)	802.11n HT20 RATES (MCS 0 MCS 15)	802.11n HT40 RATES (MCS 0 MCS 15)
36		12.0	12.0	
38	(36, 40)	12.0	12.0	12.0
40		12.0	12.0	
44		12.0	12.0	
46	(44, 48)	12.0	12.0	12.0
48		12.0	12.0	
52		19.0	19.0	
54	(52, 56)	19.0	19.0	19.0
56		19.0	19.0	
60		19.0	19.0	
62	(60, 64)	19.0	19.0	19.0
64		19.0	19.0	
100		19.0	19.0	
102	(100, 104)	19.0	19.0	19.0
104		19.0	19.0	
108		19.0	19.0	
110		19.0	19.0	19.0
112		19.0	19.0	
116		19.0	19.0	
118	(116, 120)	19.0	19.0	19.0
120		19.0	19.0	
124		19.0	19.0	
126	(124, 128)	19.0	19.0	19.0
128		19.0	19.0	
132		19.0	19.0	
134	(132, 136)	19.0	19.0	19.0
136		19.0	19.0	
140		19.0	19.0	
149		20.0	20.0	
151	(149, 153)	20.0	20.0	20.0
153		20.0	20.0	
157		20.0	20.0	
159	(157, 161)	20.0	20.0	20.0

20 MHZ CHANNEL	40 MHZ CHANNEL	LEGACY OFDM RATES (6,9,12,18,24,36,48,54 MBPS)	802.11n HT20 RATES (MCS 0 MCS 15)	802.11n HT40 RATES (MCS 0 MCS 15)
161		20.0	20.0	
165		20.0	20.0	

External panel antenna, peak gain = 6Bi

AP8163 US Domain 5 GHz External AP8163-USB Radio Maximum Conducted Transmit Power Settings

The following is an AP8163 transmit power table (US domain) per USB 3rd radio (2TX mode) in the 5 GHz band:

20 MHZ CHANNEL	40 MHZ CHANNEL	LEGACY OFDM RATES (6,9,12,18,24,36,48,54 MBPS)	802.11n HT20 RATES (MCS 0 MCS 15)	802.11n HT40 RATES (MCS 0 MCS 15)
36		11.0	11.0	
38	(36, 40)	11.0	11.0	11.0
40		11.0	11.0	
44		11.0	11.0	
46	(44, 48)	11.0	11.0	11.0
48		11.0	11.0	
52		18.0	18.0	
54	(52, 56)	18.0	18.0	18.0
56		18.0	18.0	
60		18.0	18.0	
62	(60, 64)	18.0	18.0	18.0
64		18.0	18.0	
100		12.0	12.0	
102	(100, 104)	12.0	12.0	12.0
104		19.0	19.0	
108		19.0	19.0	
110		19.0	19.0	19.0
112		19.0	19.0	
116		19.0	19.0	
118	(116, 120)	19.0	19.0	19.0
120		19.0	19.0	
124		19.0	19.0	
126	(124, 128)	19.0	19.0	19.0

20 MHZ CHANNEL	40 MHZ CHANNEL	LEGACY OFDM RATES (6,9,12,18,24,36,48,54 MBPS)	802.11n HT20 RATES (MCS 0 MCS 15)	802.11n HT40 RATES (MCS 0 MCS 15)
128		19.0	19.0	
132		19.0	19.0	
134	(132, 136)	19.0	19.0	19.0
136		19.0	19.0	
140		12.0	12.0	
142	(142, 144)	12.0	12.0	12.0
144		12.0	12.0	
149		20.0	20.0	
151	(149, 153)	20.0	20.0	20.0
153		20.0	20.0	
157		20.0	20.0	
159	(157, 161)	20.0	20.0	20.0
161		20.0	20.0	
165		20.0	20.0	

External AP8163-USB radio, peak gain = 8dBi

AP8163 US Domain 5 GHz External Dual-Polarized Antenna Maximum Conducted Transmit Power Settings

The following is an AP8163 transmit power table (US domain) per external dual-polarized antenna in the 5 GHz band:

20 MHZ CHANNEL	40 MHZ CHANNEL	LEGACY OFDM RATES (6,9,12,18,24,36,48,54 MBPS)	802.11n HT20 RATES (MCS 0 MCS 15)	802.11n HT40 RATES (MCS 0 MCS 15)
36		11.0	11.0	
38	(36, 40)	11.0	11.0	7.0
40		11.0	11.0	
44		11.0	11.0	
46	(44, 48)	11.0	11.0	11.0
48		11.0	11.0	
52		16.0	16.0	
54	(52, 56)	16.0	16.0	11.0
56		16.0	16.0	
60		16.0	16.0	
62	(60, 64)	16.0	16.0	7.0

20 MHZ CHANNEL	40 MHZ CHANNEL	LEGACY OFDM RATES (6,9,12,18,24,36,48,54 MBPS)	802.11n HT20 RATES (MCS 0 MCS 15)	802.11n HT40 RATES (MCS 0 MCS 15)
64		12.0	12.0	
100		13.0	13.0	
102	(100, 104)	17.0	17.0	5.0
104		17.0	17.0	
108		17.0	17.0	
110		17.0	17.0	13.0
112		17.0	17.0	
116		17.0	17.0	
118	(116, 120)	17.0	17.0	13.0
120		17.0	17.0	
124		17.0	17.0	
126	(124, 128)	17.0	17.0	13.0
128		17.0	17.0	
132		17.0	17.0	
134	(132, 136)	17.0	17.0	12.0
136		17.0	17.0	
140		11.0	11.0	
142	(142, 144)	20.0	20.0	12.0
144		20.0	20.0	
149		20.0	20.0	
151	(149, 153)	20.0	20.0	20.0
153		20.0	20.0	
157		20.0	20.0	
159	(157, 161)	20.0	20.0	20.0
161		20.0	20.0	
165		20.0	20.0	

External dual-polarized antenna peak gain = 9.2dBi

AP8163 EU Regulatory Domain 2.4 GHz Band

AP8163 EU Domain 2.4 GHz External Dipole Antenna Model

The following is an AP8163 transmit power table (EU domain) per external dipole antenna in the 2.4 GHz band:

20 MHZ CHANNEL	40 MHZ CHANNEL	LEGACY DSSS RATES (1, 2, 5.5, 11 MBPS)	LEGACY OFDM RATES (6,9,12,18,24,36,48,54 MBPS)	802.11n HT20 RATES (MCS 0 MCS 15)	802.11n HT40 RATES (MCS 0 MCS15)
1		4.5	4.5	4.5	
2		4.5	4.5	4.5	
3	(1, 5)	4.5	4.5	4.5	4.5
4	(2, 6)	4.5	4.5	4.5	4.5
5	(3, 7)	4.5	4.5	4.5	4.5
6	(4, 8)	4.5	4.5	4.5	4.5
7	(5, 9)	4.5	4.5	4.5	4.5
8	(6, 10)	4.5	4.5	4.5	4.5
9	(7, 11)	4.5	4.5	4.5	4.5
10	(8, 12)	4.5	4.5	4.5	4.5
11	(9, 13)	4.5	4.5	4.5	4.5
12					
13					
14					

External dipole antenna, peak gain = 10.5dBi

AP8163 EU Domain 2.4 GHz External Panel Antenna Model

The following is an AP8163 transmit power table (EU domain) per external panel antenna in the 2.4 GHz band:

20 MHZ CHANNEL	40 MHZ CHANNEL	LEGACY DSSS RATES (1, 2, 5.5, 11 MBPS)	LEGACY OFDM RATES (6,9,12,18,24,36,48,54 MBPS)	802.11n HT20 RATES (MCS 0 MCS 15)	802.11n HT40 RATES (MCS 0 MCS15)
1		6.0	6.0	7.0	
2		6.0	6.0	6.0	
3	(1, 5)	6.0	6.0	6.0	6.0
4	(2, 6)	6.0	6.0	6.0	6.0
5	(3, 7)	6.0	6.0	6.0	6.0
6	(4, 8)	6.0	6.0	6.0	6.0
7	(5, 9)	6.0	6.0	6.0	6.0
8	(6, 10)	6.0	6.0	6.0	6.0
9	(7, 11)	6.0	6.0	6.0	6.0
10	(8, 12)	6.0	6.0	6.0	6.0

20 MHZ CHANNEL	40 MHZ CHANNEL	LEGACY DSSS RATES (1, 2, 5.5, 11 MBPS)	LEGACY OFDM RATES (6,9,12,18,24,36,48,54 MBPS)	802.11n HT20 RATES (MCS 0 MCS 15)	802.11n HT40 RATES (MCS 0 MCS15)
11	(9, 13)	6.0	6.0	6.0	6.0
12					
13					
14					

External panel antenna, peak gain = 9dBi

AP8163 EU Domain 2.4 GHz External AP8163-USB Radio Maximum Conducted Transmit Power Settings

The following is an AP8163 transmit power table (EU domain) per USB 3rd radio (2TX mode) in the 2.4 GHz band:

20 MHZ CHANNEL	40 MHZ CHANNEL	LEGACY DSSS RATES (1, 2, 5.5, 11 MBPS)	LEGACY OFDM RATES (6,9,12,18,24,36,48,54 MBPS)	802.11n HT20 RATES (MCS 0 MCS 15)	802.11n HT40 RATES (MCS 0 MCS15)
1		12.0	12.0	12.0	
2		12.0	12.0	12.0	
3	(1, 5)	12.0	12.0	12.0	15.0
4	(2, 6)	12.0	12.0	12.0	12.0
5	(3, 7)	12.0	12.0	12.0	12.0
6	(4, 8)	12.0	12.0	12.0	12.0
7	(5, 9)	12.0	12.0	12.0	12.0
8	(6, 10)	12.0	12.0	12.0	12.0
9	(7, 11)	12.0	12.0	12.0	12.0
10	(9, 12)	12.0	12.0	12.0	12.0
11	(10, 13)	12.0	12.0	12.0	12.0
12					
13					
14					

External AP8163-USB radio, peak gain = 5dBi

AP8163 EU Domain 2.4 GHz Dual-Polarization Antenna Model

The following is an AP8163 transmit power table (EU domain) per dual-polarization antenna in the 2.4 GHz band:

20 MHZ CHANNEL	40 MHZ CHANNEL	LEGACY DSSS RATES (1, 2, 5.5, 11 MBPS)	LEGACY OFDM RATES (6,9,12,18,24,36,48,54 MBPS)	802.11n HT20 RATES (MCS 0 MCS 15)	802.11n HT40 RATES (MCS 0 MCS15)
1		5.5	5.5	7.0	
2		5.5	5.5	5.5	
3	(1, 5)	5.5	5.5	5.5	5.5
4	(2, 6)	5.5	5.5	5.5	5.5
5	(3, 7)	5.5	5.5	5.5	5.5
6	(4, 8)	5.5	5.5	5.5	5.5
7	(5, 9)	5.5	5.5	5.5	5.5
8	(6, 10)	5.5	5.5	5.5	5.5
9	(7, 11)	5.5	5.5	5.5	5.5
10	(8, 12)	5.5	5.5	5.5	5.5
11	(9, 13)	5.5	5.5	5.5	5.5
12					
13					
14					

Dual-polarization antenna, peak gain = 9.5dBi

AP8163 EU Regulatory Domain 5 GHz Band

AP8163 EU Domain 5 GHz External Dipole Antenna Model

The following is an AP8163 transmit power table (EU domain) per external dipole antenna in the 5 GHz band:

20 MHZ CHANNEL	40 MHZ CHANNEL	LEGACY OFDM RATES (6,9,12,18,24,36,48,54 MBPS)	802.11n HT20 RATES (MCS 0 MCS 15)	802.11n HT40 RATES (MCS 0 MCS 15)
36		7.5	7.5	
38	(36, 40)	7.5	7.5	7.5
40		7.5	7.5	
44		7.5	7.5	
46	(44, 48)	7.5	7.5	7.5
48		7.5	7.5	
52		7.5	7.5	
54	(52, 56)	7.5	7.5	7.5
56		7.5	7.5	

20 MHZ CHANNEL	40 MHZ CHANNEL	LEGACY OFDM RATES (6,9,12,18,24,36,48,54 MBPS)	802.11n HT20 RATES (MCS 0 MCS 15)	802.11n HT40 RATES (MCS 0 MCS 15)
60		7.5	7.5	
62	(60, 64)	7.5	7.5	7.5
64		7.5	7.5	
100		14.5	14.5	
102	(100, 104)	14.5	14.5	14.5
104		14.5	14.5	
108		14.5	14.5	
110		14.5	14.5	14.5
112	(108, 112)	14.5	14.5	
116		14.5	14.5	
118	(116, 120)	14.5	14.5	14.5
120		14.5	14.5	
124		14.5	14.5	
126	(124, 128)	14.5	14.5	14.5
128		14.5	14.5	
132		14.5	14.5	
134	(132, 136)	14.5	14.5	14.5
136		14.5	14.5	
140		14.5	14.5	
149				
151	(149, 153)			
153				
157				
159	(157, 161)			
161				
165				

External dipole antenna, peak gain = 10.5dBi

AP8163 EU Domain 5 GHz External Panel Antenna Model

The following is an AP8163 transmit power table (EU domain) per external panel antenna in the 5 GHz band:

20 MHZ CHANNEL	40 MHZ CHANNEL	LEGACY OFDM RATES (6,9,12,18,24,36,48,54 MBPS)	802.11n HT20 RATES (MCS 0 MCS 15)	802.11n HT40 RATES (MCS 0 MCS 15)
36		4.0	4.0	
38	(36, 40)	4.0	4.0	4.0
40		4.0	4.0	
44		4.0	4.0	
46	(44, 48)	4.0	4.0	4.0
48		4.0	4.0	
52		4.0	4.0	
54	(52, 56)	4.0	4.0	4.0
56		4.0	4.0	
60		4.0	4.0	
62	(60, 64)	4.0	4.0	4.0
64		4.0	4.0	
100		11.0	11.0	
102	(100, 104)	11.0	11.0	11.0
104		11.0	11.0	
108		11.0	11.0	
110		11.0	11.0	11.0
112	(108, 112)	11.0	11.0	
116		11.0	11.0	
118	(116, 120)	11.0	11.0	11.0
120		11.0	11.0	
124		11.0	11.0	
126	(124, 128)	11.0	11.0	11.0
128		11.0	11.0	
132		11.0	11.0	
134	(132, 136)	11.0	11.0	11.0
136		11.0	11.0	
140		11.0	11.0	
149				
151	(149, 153)			
153				
157				
159	(157, 161)			

20 MHZ CHANNEL	40 MHZ CHANNEL	LEGACY OFDM RATES (6,9,12,18,24,36,48,54 MBPS)	802.11n HT20 RATES (MCS 0 MCS 15)	802.11n HT40 RATES (MCS 0 MCS 15)
161				
165				

External panel antenna, peak gain = 14dBi

AP8163 EU Domain 5 GHz External AP8163-USB Radio Maximum Conducted Transmit Power Settings

The following is an AP8163 transmit power table (EU domain) per USB 3rd radio (2TX mode) in the 5 GHz band:

20 MHZ CHANNEL	40 MHZ CHANNEL	LEGACY OFDM RATES (6,9,12,18,24,36,48,54 MBPS)	802.11n HT20 RATES (MCS 0 MCS 15)	802.11n HT40 RATES (MCS 0 MCS 15)
36		11.0	11.0	
38	(36, 40)	11.0	11.0	11.0
40		11.0	11.0	
44		11.0	11.0	
46	(44, 48)	11.0	11.0	11.0
48		11.0	11.0	
52		18.0	18.0	
54	(52, 56)	18.0	18.0	18.0
56		18.0	18.0	
60		18.0	18.0	
62	(60, 64)	18.0	18.0	18.0
64		18.0	18.0	
100		12.0	12.0	
102	(100, 104)	12.0	12.0	12.0
104		19.0	19.0	
108		19.0	19.0	
110		19.0	19.0	19.0
112		19.0	19.0	
116		19.0	19.0	
118	(116, 120)	19.0	19.0	19.0
120		19.0	19.0	
124		19.0	19.0	
126	(124, 128)	19.0	19.0	19.0

20 MHZ CHANNEL	40 MHZ CHANNEL	LEGACY OFDM RATES (6,9,12,18,24,36,48,54 MBPS)	802.11n HT20 RATES (MCS 0 MCS 15)	802.11n HT40 RATES (MCS 0 MCS 15)
128		19.0	19.0	
132		19.0	19.0	
134	(132, 136)	19.0	19.0	19.0
136		19.0	19.0	
140		12.0	12.0	
142	(142, 144)			
144				
149				
151	(149, 153)			
153				
157				
159	(157, 161)			
161				
165				

External AP8163-USB radio, peak gain = 8dBi

AP8163 EU Domain 5 GHz Dual-Polarization Antenna Maximum Conducted Transmit Power Settings

The following is an AP8163 transmit power table (EU domain) per dual-polarization antenna in the 5 GHz band:

20 MHZ CHANNEL	40 MHZ CHANNEL	LEGACY OFDM RATES (6,9,12,18,24,36,48,54 MBPS)	802.11n HT20 RATES (MCS 0 MCS 15)	802.11n HT40 RATES (MCS 0 MCS 15)
36		9.0	9.0	
38	(36, 40)	9.0	9.0	9.0
40		9.0	9.0	
44		9.0	9.0	
46	(44, 48)	9.0	9.0	9.0
48		9.0	9.0	
52		9.0	9.0	
54	(52, 56)	9.0	9.0	9.0
56		9.0	9.0	
60		9.0	9.0	
62	(60, 64)	9.0	9.0	9.0

20 MHZ CHANNEL	40 MHZ CHANNEL	LEGACY OFDM RATES (6,9,12,18,24,36,48,54 MBPS)	802.11n HT20 RATES (MCS 0 MCS 15)	802.11n HT40 RATES (MCS 0 MCS 15)
64		9.0	9.0	
100		12.0	12.0	
102	(100, 104)	12.0	12.0	12.0
104		12.0	12.0	
108		12.0	12.0	
110		12.0	12.0	12.0
112		12.0	12.0	
116		12.0	12.0	
118	(116, 120)	12.0	12.0	12.0
120		12.0	12.0	
124		12.0	12.0	
126	(124, 128)	12.0	12.0	12.0
128		12.0	12.0	
132		12.0	12.0	
134	(132, 136)	12.0	12.0	12.0
136		12.0	12.0	
140		12.0	12.0	
142	(142, 144)			
144				
149				
151	(149, 153)			
153				
157				
159	(157, 161)			
161				
165				

Dual-polarization antenna, peak gain = 9.2dBi

20 AP8232 Regulatory Domains

AP8232 US Regulatory Domain 2.4 GHz Band
 AP8232 US Regulatory Domain 5 GHz Band
 AP8232 EU Regulatory Domain 2.4 GHz Band
 AP8232 EU Regulatory Domain 5 GHz Band
 AP8232 Japan Regulatory Domain 2.4 GHz Band
 AP8232 Japan Regulatory Domain 5 GHz Band

AP8232 US Regulatory Domain 2.4 GHz Band

AP8232 US Domain 2.4 GHz External Dipole Antenna Maximum Conducted Transmit Power Settings

The following is a transmit power table (US domain) per external dipole antenna in the 2.4 GHz band:

20 MHZ CHANNEL	40 MHZ CHANNEL	LEGACY DSSS RATES (1, 2, 5.5, 11 MBPS)	LEGACY OFDM RATES (6,9,12,18,24,36,48,54 MBPS)	802.11n HT20 RATES (MCS 0 MCS 15)	802.11n HT40 RATES (MCS 0 MCS15)
1		17.0	17.0	16.0	
2		17.0	17.0	17.0	
3	(1, 5)	18.0	21.0	21.0	13.0
4	(2, 6)	18.0	21.0	21.0	13.0
5	(3, 7)	18.0	21.0	21.0	19.0
6	(4, 8)	18.0	21.0	21.0	19.0
7	(5, 9)	18.0	21.0	21.0	19.0
8	(6, 10)	18.0	21.0	21.0	10.0
9	(7, 11)	18.0	21.0	21.0	10.0
10		18.0	17.0	17.0	
11		18.0	17.0	17.0	

External dipole antenna, peak gain = 10.5dBi

AP8232 US Domain 2.4 GHz External Panel Antenna Maximum Conducted Transmit Power Settings

The following is a transmit power table (US domain) per external panel antenna in the 2.4 GHz band:

20 MHZ CHANNEL	40 MHZ CHANNEL	LEGACY DSSS RATES (1, 2, 5.5, 11 MBPS)	LEGACY OFDM RATES (6,9,12,18,24,36,48,54 MBPS)	802.11n HT20 RATES (MCS 0 MCS 15)	802.11n HT40 RATES (MCS 0 MCS15)
1		12.0	13.0	13.0	
2		17.0	17.0	17.0	
3	(1, 5)	17.0	17.0	17.0	10.0
4	(2, 6)	17.0	17.0	17.0	10.0
5	(3, 7)	17.0	17.0	17.0	14.0
6	(4, 8)	17.0	17.0	17.0	14.0
7	(5, 9)	17.0	17.0	17.0	14.0
8	(6, 10)	17.0	17.0	17.0	6.0
9	(7, 11)	17.0	17.0	17.0	6.0
10		17.0	17.0	17.0	
11		16.0	15.0	15.0	

External Panel antenna, peak gain = 15dBi

AP8232 US Domain 2.4 GHz External Yagi Antenna Maximum Conducted Transmit Power Settings

The following is a transmit power table (US domain) per external yagi antenna in the 2.4 GHz band:

20 MHZ CHANNEL	40 MHZ CHANNEL	LEGACY DSSS RATES (1, 2, 5.5, 11 MBPS)	LEGACY OFDM RATES (6,9,12,18,24,36,48,54 MBPS)	802.11n HT20 RATES (MCS 0 MCS 15)	802.11n HT40 RATES (MCS 0 MCS15)
1		8.0	9.0	9.0	
2		8.0	13.0	13.0	
3	(1, 5)	17.0	13.0	13.0	9.0
4	(2, 6)	17.0	13.0	13.0	9.0
5	(3, 7)	17.0	13.0	13.0	12.0
6	(4, 8)	17.0	13.0	13.0	12.0
7	(5, 9)	17.0	13.0	13.0	12.0
8	(6, 10)	17.0	13.0	13.0	6.0
9	(7, 11)	17.0	13.0	13.0	6.0
10		6.0	13.0	13.0	
11		6.0	13.0	13.0	

External yagi antenna, peak gain = 14.0dBi

AP8232 US Domain 2.4 GHz External Patch Antenna Maximum Conducted Transmit Power Settings

The following is a transmit power table (US domain) per external patch antenna in the 2.4 GHz band:

20 MHZ CHANNEL	40 MHZ CHANNEL	LEGACY DSSS RATES (1, 2, 5.5, 11 MBPS)	LEGACY OFDM RATES (6,9,12,18,24,36,48,54 MBPS)	802.11n HT20 RATES (MCS 0 MCS 15)	802.11n HT40 RATES (MCS 0 MCS15)
1		20.0	17.0	17.0	
2		23.0	23.0	23.0	
3	(1, 5)	23.0	23.0	23.0	13.0
4	(2, 6)	23.0	23.0	23.0	13.0
5	(3, 7)	23.0	23.0	23.0	18.0
6	(4, 8)	23.0	23.0	23.0	18.0
7	(5, 9)	23.0	23.0	23.0	18.0
8	(6, 10)	23.0	23.0	23.0	14.0
9	(7, 11)	23.0	23.0	23.0	14.0
10		23.0	23.0	23.0	
11		19.0	17.0	17.0	

External patch antenna, peak gain = 4dBi

AP8232 US Domain 2.4 GHz Facade Antenna Maximum Conducted Transmit Power Settings

The following is a transmit power table (US domain) per internal facade antenna in the 2.4 GHz band:

20 MHZ CHANNEL	40 MHZ CHANNEL	LEGACY DSSS RATES (1, 2, 5.5, 11 MBPS)	LEGACY OFDM RATES (6,9,12,18,24,36,48,54 MBPS)	802.11n HT20 RATES (MCS 0 MCS 15)	802.11n HT40 RATES (MCS 0 MCS15)
1		20.0	18.0	18.0	
2		23.0	23.0	23.0	
3	(1, 5)	23.0	23.0	23.0	14.0
4	(2, 6)	23.0	23.0	23.0	18.0
5	(3, 7)	23.0	23.0	23.0	18.0
6	(4, 8)	23.0	23.0	23.0	18.0
7	(5, 9)	23.0	23.0	23.0	18.0
8	(6, 10)	23.0	23.0	23.0	18.0
9	(7, 11)	23.0	23.0	23.0	14.0
10		23.0	23.0	23.0	
11		20.0	19.0	19.0	

Facade antenna, peak gain = 3.5dBi

AP8232 US Regulatory Domain 5 GHz Band

AP8232 US Domain 5 GHz External Dipole Antenna Model

The following is a transmit power table (US domain) per external dipole antenna in the 5 GHz band:

20 MHZ CHANNEL	40 MHZ CHANNEL	80 MHZ CHANNELS	LEGACY OFDM RATES (6,9,12,18,24,36,48,54 MBPS)	802.11n HT20 RATES (MCS 0 MCS 15)	802.11n HT40 RATES (MCS 0 MCS 15)	802.11n HT80 RATES (MCS 0 MCS 15)
36			8.0	10.5		
38	(36, 40)		7.0	10.5	11.0	
40			7.0	10.5		
42		(36, 40, 44, 48)	7.0	10.5		10.5
44			7.0	10.5		
46	(44, 48)		7.0	10.5	11.0	
48			7.0	10.5		
52			13.0	13.0		
54	(52, 56)		13.0	13.0	15.0	
56			13.0	13.0		
58		(52, 56, 60, 64)	13.0	13.0		10.5
60			13.0	13.0		
62	(60, 64)		13.0	13.0	15.0	
64			13.0	13.0		
100			13.0	13.0		
102	(100, 104)		13.0	13.0	13.0	
104			13.0	13.0		
106		(100, 104, 108, 112)	13.0	13.0		7.5
108			13.0	13.0		
110			13.0	13.0	13.0	
112			13.0	13.0		
114			13.0	13.0		
116			13.0	13.0		
118	(116, 120)		13.0	13.0	13.0	
120			13.0	13.0		

20 MHZ CHANNEL	40 MHZ CHANNEL	80 MHZ CHANNELS	LEGACY OFDM RATES (6,9,12,18,24,36,48,54 MBPS)	802.11n HT20 RATES (MCS 0 MCS 15)	802.11n HT40 RATES (MCS 0 MCS 15)	802.11n HT80 RATES (MCS 0 MCS 15)
122		(116, 120, 124, 128)	13.0	13.0		
124			13.0	13.0		
126	(124, 128)		13.0	13.0		
128			13.0	13.0		
130			13.0	13.0		
132			13.0	13.0		
134	(132, 136)		13.0	13.0	13.0	
136			13.0	13.0		
138			13.0	13.0		
140			8.5	8.5		
142			8.5	8.5	8.5	
144			8.5	8.5		
149			20.0	20.0		
151	(149, 153)		20.0	20.0	20.0	
153			20.0	20.0		
155		(149, 153, 157, 161)	20.0	20.0		20.0
157			20.0	20.0		
159	(157, 161)		20.0	20.0	20.0	
161			20.0	20.0		
165			20.0	20.0		

External dipole antenna, peak gain = 10.5dBi

AP8232 US Domain 5 GHz External Panel Antenna Model

The following is a transmit power table (US domain) per external panel antenna in the 5 GHz band:

20 MHZ CHANNEL	40 MHZ CHANNEL	80 MHZ CHANNELS	LEGACY OFDM RATES (6,9,12,18,24,36,48,54 MBPS)	802.11n HT20 RATES (MCS 0 MCS 15)	802.11n HT40 RATES (MCS 0 MCS 15)	802.11n HT80 RATES (MCS 0 MCS 15)
36			6.0	6.0		
38	(36, 40)		6.0	6.0	10.0	
40			6.0	6.0		

20 MHZ CHANNEL	40 MHZ CHANNEL	80 MHZ CHANNELS	LEGACY OFDM RATES (6,9,12,18,24,36,48,54 MBPS)	802.11n HT20 RATES (MCS 0 MCS 15)	802.11n HT40 RATES (MCS 0 MCS 15)	802.11n HT80 RATES (MCS 0 MCS 15)
42		(36, 40, 44, 48)	6.0	6.0		6.0
44			6.0	6.0		
46	(44, 48)		6.0	6.0	10.0	
48			6.0	6.0		
52			9.0	12.0		
54	(52, 56)		9.0	12.0	13.5	
56			9.0	12.0		
58		(52, 56, 60, 64)	9.0	12.0		6.0
60			9.0	12.0		
62	(60, 64)		5.0	8.0	11.5	
64			5.0	8.0		
100			5.0	8.0		
102	(100, 104)		9.0	12.0	11.5	
104			9.0	12.0		
106		(100, 104, 108, 112)	9.0	12.0		3.5
108			9.0	12.0		
110			9.0	12.0	11.5	
112			9.0	12.0		
114			9.0	12.0		
116			9.0	12.0		
118	(116, 120)		9.0	12.0	11.5	
120			9.0	12.0		
122		(116, 120, 124, 128)	9.0	12.0		
124			9.0	12.0		
126	(124, 128)		9.0	12.0	11.5	
128			9.0	12.0		
130			9.0	12.0		
132			9.0	12.0		
134	(132, 136)		9.0	12.0	11.5	
136			9.0	12.0		
138			3.5	6.5		

20 MHZ CHANNEL	40 MHZ CHANNEL	80 MHZ CHANNELS	LEGACY OFDM RATES (6,9,12,18,24,36,48,54 MBPS)	802.11n HT20 RATES (MCS 0 MCS 15)	802.11n HT40 RATES (MCS 0 MCS 15)	802.11n HT80RATES (MCS 0 MCS 15)
140			3.5	6.5		
142			3.5	6.5	11.5	
144			3.5	6.5		
149			20.0	20.0		
151	(149, 153)		20.0	20.0	20.0	
153			20.0	20.0		
155		(149, 153, 157, 161)	20.0	20.0		20.0
157			20.0	20.0		
159	(157, 161)		20.0	20.0	20.0	
161			20.0	20.0		
165			20.0	20.0		

External panel antenna, peak gain = 12dBi

AP8232 US Domain 5 GHz External Yagi Antenna Model

The following is a transmit power table (US domain) per external yagi antenna in the 5 GHz band:

20 MHZ CHANNEL	40 MHZ CHANNEL	80 MHZ CHANNELS	LEGACY OFDM RATES (6,9,12,18,24,36,48,54 MBPS)	802.11n HT20 RATES (MCS 0 MCS 15)	802.11n HT40 RATES (MCS 0 MCS 15)	802.11n HT80RATES (MCS 0 MCS 15)
36			7.5	10.5		
38	(36, 40)		7.5	10.5	11.5	
40			7.5	10.5		
42		(36, 40, 44, 48)	7.5	10.5		7.0
44			7.5	10.5		
46	(44, 48)		7.5	10.5	11.5	
48			7.5	10.5		
52			11.5	14.5		
54	(52, 56)		11.5	14.5	13.0	
56			8.5	11.5		
58		(52, 56, 60, 64)	11.5	14.5		4.0
60			11.5	14.5		

20 MHZ CHANNEL	40 MHZ CHANNEL	80 MHZ CHANNELS	LEGACY OFDM RATES (6,9,12,18,24,36,48,54 MBPS)	802.11n HT20 RATES (MCS 0 MCS 15)	802.11n HT40 RATES (MCS 0 MCS 15)	802.11n HT80 RATES (MCS 0 MCS 15)
62	(60, 64)		6.0	9.0	10.0	
64			6.0	9.0		
100			10.0	13.0		
102	(100, 104)		10.0	13.0	14.0	
104			10.0	13.0		
106		(100, 104, 108, 112)	10.0	13.0		4.0
108			10.0	13.0		
110			10.0	13.0	14.0	
112			10.0	13.0		
114			10.0	13.0		
116			10.0	13.0		
118	(116, 120)		10.0	13.0	14.0	
120			10.0	13.0		
122		(116, 120, 124, 128)	10.0	13.0		
124			10.0	13.0		
126	(124, 128)		10.0	13.0	14.0	
128			10.0	13.0		
130			10.0	13.0		
132			10.0	13.0		
134	(132, 136)		10.0	13.0	14.0	
136			10.0	13.0		
138			10.0	13.0		
140			6.5	9.5		
142			6.5	9.5	13.0	
144			6.5	9.5		
149			20.0	20.0		
151	(149, 153)		20.0	20.0	20.0	
153			20.0	20.0		
155		(149, 153, 157, 161)	20.0	20.0		20.0
157			20.0	20.0		
159	(157, 161)		20.0	20.0	20.0	

20 MHZ CHANNEL	40 MHZ CHANNEL	80 MHZ CHANNELS	LEGACY OFDM RATES (6,9,12,18,24,36,48,54 MBPS)	802.11n HT20 RATES (MCS 0 MCS 15)	802.11n HT40 RATES (MCS 0 MCS 15)	802.11n HT80 RATES (MCS 0 MCS 15)
161			20.0	20.0		
165			20.0	20.0		

Panel antenna, peak gain = 10.5dBi

AP8232 US Domain 5 GHz External Patch Antenna Model

The following is a transmit power table (US domain) per external patch antenna in the 5 GHz band:

20 MHZ CHANNEL	40 MHZ CHANNEL	80 MHZ CHANNELS	LEGACY OFDM RATES (6,9,12,18,24,36,48,54 MBPS)	802.11n HT20 RATES (MCS 0 MCS 15)	802.11n HT40 RATES (MCS 0 MCS 15)	802.11n HT80 RATES (MCS 0 MCS 15)
36			10.0	13.0		
38	(36, 40)		10.0	13.0	13.5	
40			10.0	13.0		
42		(36, 40, 44, 48)	10.0	13.0		13.0
44			10.0	13.0		
46	(44, 48)		10.0	13.0	13.5	
48			10.0	13.0		
52			13.0	16.0		
54	(52, 56)		13.0	16.0	16.0	
56			13.0	16.0		
58		(52, 56, 60, 64)	13.0	16.0		13.5
60			13.0	16.0		
62	(60, 64)		13.0	16.0	14.0	
64			9.0	12.0		
100			11.5	12.0		
102	(100, 104)		11.5	12.0	15.0	
104			11.5	15.0		
106		(100, 104, 108, 112)	12.0	15.0		12.0
108			12.0	15.0		
110			12.0	15.0	16.0	
112			12.0	15.0		

20 MHZ CHANNEL	40 MHZ CHANNEL	80 MHZ CHANNELS	LEGACY OFDM RATES (6,9,12,18,24,36,48,54 MBPS)	802.11n HT20 RATES (MCS 0 MCS 15)	802.11n HT40 RATES (MCS 0 MCS 15)	802.11n HT80RATES (MCS 0 MCS 15)
114			12.0	15.0		
116			12.0	15.0		
118	(116, 120)		12.0	15.0	16.0	
120			12.0	15.0		
122		(116, 120, 124, 128)	12.0	15.0		
124			12.0	15.0		
126	(124, 128)		12.0	15.0	16.0	
128			12.0	15.0		
130			12.0	15.0		
132			12.0	15.0		
134	(132, 136)		12.0	15.0	16.0	
136			12.0	15.0		
138			12.0	15.0		
140			9.0	12.0		
142			9.0	12.0	12.0	
144			9.0	12.0		
149			20.0	20.0		
151	(149, 153)		20.0	20.0	20.0	
153			20.0	20.0		
155		(149, 153, 157, 161)	20.0	20.0		20.0
157			20.0	20.0		
159	(157, 161)		20.0	20.0	20.0	
161			20.0	20.0		
165			20.0	20.0		

External patch antenna, peak gain = 3.8dBi

AP8232 US Domain 5 GHz Facade Antenna Model

The following is a transmit power table (US domain) per external facade antenna in the 5 GHz band:

20 MHZ CHANNEL	40 MHZ CHANNEL	80 MHZ CHANNELS	LEGACY OFDM RATES (6,9,12,18,24,36,48,54 MBPS)	802.11n HT20 RATES (MCS 0 MCS 15)	802.11n HT40 RATES (MCS 0 MCS 15)	802.11n HT80 RATES (MCS 0 MCS 15)
36			10.0	13.0		
38	(36, 40)		10.0	13.0	13.0	
40			10.0	13.0		
42		(36, 40, 44, 48)	10.0	13.0		13.0
44			10.0	13.0		
46	(44, 48)		10.0	13.0	13.0	
48			10.0	13.0		
52			11.0	14.0		
54	(52, 56)		11.0	14.0	16.0	
56			11.0	14.0		
58		(52, 56, 60, 64)	11.0	14.0		13.5
60			11.0	14.0		
62	(60, 64)		11.0	14.0	16.0	
64			11.0	14.0		
100			11.0	14.0		
102	(100, 104)		11.0	14.0	16.0	
104			11.0	14.0		
106		(100, 104, 108, 112)	11.0	14.0		12.0
108			11.0	14.0		
110			11.0	14.0	16.0	
112			11.0	14.0		
114			11.0	14.0		
116			11.0	14.0		
118	(116, 120)		11.0	14.0	16.0	
120			11.0	14.0		
122		(116, 120, 124, 128)	11.0	14.0		
124			11.0	14.0		
126	(124, 128)		11.0	14.0	16.0	
128			11.0	14.0		
130			11.0	14.0		
132			11.0	14.0		

20 MHZ CHANNEL	40 MHZ CHANNEL	80 MHZ CHANNELS	LEGACY OFDM RATES (6,9,12,18,24,36,48,54 MBPS)	802.11n HT20 RATES (MCS 0 MCS 15)	802.11n HT40 RATES (MCS 0 MCS 15)	802.11n HT80 RATES (MCS 0 MCS 15)
134	(132, 136)		11.0	14.0	13.0	
136			11.0	14.0		
138			11.0	14.0		
140			11.0	14.0		
142			11.0	14.0	14.45	
144			11.0	14.0		
149			20.0	20.0		
151	(149, 153)		20.0	20.0	20.0	
153			20.0	20.0		
155		(149, 153, 157, 161)	20.0	20.0		20.0
157			20.0	20.0		
159	(157, 161)		20.0	20.0	20.0	
161			20.0	20.0		
165			20.0	20.0		

Facade antenna, peak gain = 4.0dBi

AP8232 EU Regulatory Domain 2.4 GHz Band

AP8232 EU Domain 2.4 GHz External Dipole Antenna Model

The following is a transmit power table (EU domain) per external dipole antenna in the 2.4 GHz band:

20 MHZ CHANNEL	40 MHZ CHANNEL	LEGACY DSSS RATES (1, 2, 5.5, 11 MBPS)	LEGACY OFDM RATES (6,9,12,18,24,36,48,54 MBPS)	802.11n HT20 RATES (MCS 0 MCS 15)	802.11n HT40 RATES (MCS 0 MCS 15)
1		4.5	4.5	4.5	
2		4.5	4.5	4.5	
3	(1, 5)	4.5	4.5	4.5	4.5
4	(2, 6)	4.5	4.5	4.5	4.5
5	(3, 7)	4.5	4.5	4.5	4.5
6	(4, 8)	4.5	4.5	4.5	4.5
7	(5, 9)	4.5	4.5	4.5	4.5
8	(6, 10)	4.5	4.5	4.5	4.5

20 MHZ CHANNEL	40 MHZ CHANNEL	LEGACY DSSS RATES (1, 2, 5.5, 11 MBPS)	LEGACY OFDM RATES (6,9,12,18,24,36,48,54 MBPS)	802.11n HT20 RATES (MCS 0 MCS 15)	802.11n HT40 RATES (MCS 0 MCS15)
9	(7, 11)	4.5	4.5	4.5	4.5
10	(8, 12)	4.5	4.5	4.5	4.5
11	(9, 13)	4.5	4.5	4.5	4.5
12		4.5	4.5	4.5	
13		4.5	4.5	4.5	
14					

External dipole antenna, peak gain = 10.5dBi

AP8232 EU Domain 2.4 GHz External Panel Antenna Model

The following is a transmit power table (EU domain) per external panel antenna in the 2.4 GHz band:

20 MHZ CHANNEL	40 MHZ CHANNEL	LEGACY DSSS RATES (1, 2, 5.5, 11 MBPS)	LEGACY OFDM RATES (6,9,12,18,24,36,48,54 MBPS)	802.11n HT20 RATES (MCS 0 MCS 15)	802.11n HT40 RATES (MCS 0 MCS15)
1		4.0	4.0	4.0	
2		4.0	4.0	4.0	
3	(1, 5)	4.0	4.0	4.0	4.0
4	(2, 6)	4.0	4.0	4.0	4.0
5	(3, 7)	4.0	4.0	4.0	4.0
6	(4, 8)	4.0	4.0	4.0	4.0
7	(5, 9)	4.0	4.0	4.0	4.0
8	(6, 10)	4.0	4.0	4.0	4.0
9	(7, 11)	4.0	4.0	4.0	4.0
10	(8, 12)	4.0	4.0	4.0	4.0
11	(9, 13)	4.0	4.0	4.0	4.0
12		4.0	4.0	4.0	
13		4.0	4.0	4.0	
14					

External panel antenna, peak gain = 11dBi

AP8232 EU Domain 2.4 GHz External Patch Antenna Model

The following is a transmit power table (EU domain) per external patch antenna in the 2.4 GHz band:

20 MHZ CHANNEL	40 MHZ CHANNEL	LEGACY DSSS RATES (1, 2, 5.5, 11 MBPS)	LEGACY OFDM RATES (6,9,12,18,24,36,48,54 MBPS)	802.11n HT20 RATES (MCS 0 MCS 15)	802.11n HT40 RATES (MCS 0 MCS15)
1		11.0	11.0	11.0	
2		11.0	11.0	11.0	
3	(1, 5)	11.0	11.0	11.0	11.0
4	(2, 6)	11.0	11.0	11.0	11.0
5	(3, 7)	11.0	11.0	11.0	11.0
6	(4, 8)	11.0	11.0	11.0	11.0
7	(5, 9)	11.0	11.0	11.0	11.0
8	(6, 10)	11.0	11.0	11.0	11.0
9	(7, 11)	11.0	11.0	11.0	11.0
10		11.0	11.0	11.0	
11		11.0	11.0	11.0	
12					
13					
14					

External patch antenna, peak gain = 4dBi

AP8232 EU Domain 2.4 GHz Facade Antenna Model

The following is a transmit power table (EU domain) per internal facade antenna in the 2.4 GHz band:

20 MHZ CHANNEL	40 MHZ CHANNEL	LEGACY DSSS RATES (1, 2, 5.5, 11 MBPS)	LEGACY OFDM RATES (6,9,12,18,24,36,48,54 MBPS)	802.11n HT20 RATES (MCS 0 MCS 15)	802.11n HT40 RATES (MCS 0 MCS15)
1		11.5	11.5	11.5	
2		11.5	11.5	11.5	
3	(1, 5)	11.5	11.5	11.5	11.5
4	(2, 6)	11.5	11.5	11.5	11.5
5	(3, 7)	11.5	11.5	11.5	11.5
6	(4, 8)	11.5	11.5	11.5	11.5
7	(5, 9)	11.5	11.5	11.5	11.5
8	(6, 10)	11.5	11.5	11.5	11.5
9	(7, 11)	11.5	11.5	11.5	11.5
10		11.5	11.5	11.5	
11		11.5	11.5	11.5	

20 MHZ CHANNEL	40 MHZ CHANNEL	LEGACY DSSS RATES (1, 2, 5.5, 11 MBPS)	LEGACY OFDM RATES (6,9,12,18,24,36,48,54 MBPS)	802.11n HT20 RATES (MCS 0 MCS 15)	802.11n HT40 RATES (MCS 0 MCS15)
12					
13					
14					

Facade antenna, peak gain = 3.5dBi

AP8232 EU Regulatory Domain 5 GHz Band

AP8232 EU Domain 5 GHz External Dipole Antenna Model

The following is a transmit power table (EU domain) per external dipole antenna in the 5 GHz band:

20 MHZ CHANNEL	40 MHZ CHANNEL	80 MHZ CHANNELS	LEGACY OFDM RATES (6,9,12,18,24,36,48,54 MBPS)	802.11n HT20 RATES (MCS 0 MCS 15)	802.11n HT40 RATES (MCS 0 MCS 15)	802.11n HT80 RATES (MCS 0 MCS 15)
36			7.5	7.5		
38	(36, 40)		7.5	7.5	7.5	
40			7.5	7.5		
42		(36, 40, 44, 48)	7.5	7.5		7.5
44			7.5	7.5		
46	(44, 48)		7.5	7.5	7.5	
48			7.5	7.5		
52			4.5	4.5		
54	(52, 56)		4.5	4.5	4.5	
56			4.5	4.5		
58		(52, 56, 60, 64)	4.5	4.5		4.5
60			4.5	4.5		
62	(60, 64)		4.5	4.5	4.5	
64			4.5	4.5		
100			11.5	11.5		
102	(100, 104)		11.5	11.5	11.5	
104			11.5	11.5		
106		(100, 104, 108, 112)	11.5	11.5		11.5

20 MHZ CHANNEL	40 MHZ CHANNEL	80 MHZ CHANNELS	LEGACY OFDM RATES (6,9,12,18,24,36,48,54 MBPS)	802.11n HT20 RATES (MCS 0 MCS 15)	802.11n HT40 RATES (MCS 0 MCS 15)	802.11n HT80 RATES (MCS 0 MCS 15)
108			11.5	11.5		
110			11.5	11.5	11.5	
112			11.5	11.5		
114			11.5	11.5		
116			11.5	11.5		
118	(116, 120)		11.5	11.5	11.5	
120			11.5	11.5		
122		(116, 120, 124, 128)	11.5	11.5		11.5
124			11.5	11.5		
126	(124, 128)		11.5	11.5		
128			11.5	11.5		
130			11.5	11.5		
132			11.5	11.5		
134	(132, 136)		11.5	11.5	11.5	
136			11.5	11.5		
138			11.5	11.5		
140			11.5	11.5		
142			11.5	11.5	11.5	
144			11.5	11.5		
149						
151	(149, 153)					
153						
155		(149, 153, 157, 161)				
157						
159	(157, 161)					
161						
165						

External dipole antenna, peak gain = 10.5dBi

AP8232 EU Domain 5 GHz External Panel Antenna Model

The following is a transmit power table (EU domain) per external panel antenna in the 5 GHz band:

20 MHZ CHANNEL	40 MHZ CHANNEL	80 MHZ CHANNELS	LEGACY OFDM RATES (6,9,12,18,24,36,48,54 MBPS)	802.11n HT20 RATES (MCS 0 MCS 15)	802.11n HT40 RATES (MCS 0 MCS 15)	802.11n HT80 RATES (MCS 0 MCS 15)
36			4.0	4.0		
38	(36, 40)		4.0	4.0	4.0	
40			4.0	4.0		
42		(36, 40, 44, 48)	4.0	4.0		4.0
44			4.0	4.0		
46	(44, 48)		4.0	4.0	4.0	
48			4.0	4.0		
52			1.0	1.0		
54	(52, 56)		1.0	1.0	1.0	1.0
56			1.0	1.0		
58		(52, 56, 60, 64)	1.0	1.0		1.0
60			1.0	1.0		
62	(60, 64)		1.0	1.0	1.0	
64			1.0	1.0		
100			8.0	8.0		
102	(100, 104)		8.0	8.0	8.0	
104			8.0	8.0		
106		(100, 104, 108, 112)	8.0	8.0		8.0
108			8.0	8.0		
110			8.0	8.0	8.0	
112			8.0	8.0		
114			8.0	8.0		
116			8.0	8.0		
118	(116, 120)		8.0	8.0	8.0	
120			8.0	8.0		
122		(116, 120, 124, 128)	8.0	8.0		8.0
124			8.0	8.0		
126	(124, 128)		8.0	8.0	8.0	
128			8.0	8.0		
130			8.0	8.0		
132			8.0	8.0		

20 MHZ CHANNEL	40 MHZ CHANNEL	80 MHZ CHANNELS	LEGACY OFDM RATES (6,9,12,18,24,36,48,54 MBPS)	802.11n HT20 RATES (MCS 0 MCS 15)	802.11n HT40 RATES (MCS 0 MCS 15)	802.11n HT80 RATES (MCS 0 MCS 15)
134	(132, 136)		8.0	8.0	8.0	
136			8.0	8.0		
138			8.0	8.0		
140			8.0	8.0		
142			8.0	8.0	8.0	
144			8.0	8.0		
149						
151	(149, 153)					
153						
155		(149, 153, 157, 161)				
157						
159	(157, 161)					
161						
165						

External panel antenna, peak gain = 14dBi

AP8232 EU Domain 5 GHz External Yagi Antenna Model

The following is a transmit power table (EU domain) per external yagi antenna in the 5 GHz band:

20 MHZ CHANNEL	40 MHZ CHANNEL	80 MHZ CHANNELS	LEGACY OFDM RATES (6,9,12,18,24,36,48,54 MBPS)	802.11n HT20 RATES (MCS 0 MCS 15)	802.11n HT40 RATES (MCS 0 MCS 15)	802.11n HT80 RATES (MCS 0 MCS 15)
36			7.5	7.5		
38	(36, 40)		7.5	7.5	7.5	
40			7.5	7.5		
42		(36, 40, 44, 48)	7.5	7.5		7.5
44			7.5	7.5		
46	(44, 48)		7.5	7.5	7.5	
48			7.5	7.5		
52			4.5	4.5		
54	(52, 56)		4.5	4.5	4.5	
56			4.5	4.5		

20 MHZ CHANNEL	40 MHZ CHANNEL	80 MHZ CHANNELS	LEGACY OFDM RATES (6,9,12,18,24,36,48,54 MBPS)	802.11n HT20 RATES (MCS 0 MCS 15)	802.11n HT40 RATES (MCS 0 MCS 15)	802.11n HT80 RATES (MCS 0 MCS 15)
58		(52, 56, 60, 64)	4.5	4.5		4.5
60			4.5	4.5		
62	(60, 64)		4.5	4.5	4.5	
64			4.5	4.5		
100			11.5	11.5		
102	(100, 104)		11.5	11.5	11.5	
104			11.5	11.5		
106		(100, 104, 108, 112)	11.5	11.5		11.5
108			11.5	11.5		
110			11.5	11.5	11.5	
112			11.5	11.5		
114			11.5	11.5		
116			11.5	11.5		
118	(116, 120)		11.5	11.5	11.5	
120			11.5	11.5		
122		(116, 120, 124, 128)	11.5	11.5		11.5
124			11.5	11.5		
126	(124, 128)		11.5	11.5	11.5	
128			11.5	11.5		
130			11.5	11.5		
132			11.5	11.5		
134	(132, 136)		11.5	11.5	11.5	
136			11.5	11.5		
138			11.5	11.5		
140			11.5	11.5		
142			11.5	11.5	11.5	
144			11.5	11.5		
149						
151	(149, 153)					
153						
155		(149, 153, 157, 161)				

20 MHZ CHANNEL	40 MHZ CHANNEL	80 MHZ CHANNELS	LEGACY OFDM RATES (6,9,12,18,24,36,48,54 MBPS)	802.11n HT20 RATES (MCS 0 MCS 15)	802.11n HT40 RATES (MCS 0 MCS 15)	802.11n HT80 RATES (MCS 0 MCS 15)
157						
159	(157, 161)					
161						
165						

External yagi antenna, peak gain = 10.5dBi

AP8232 EU Domain 5 GHz External Patch Antenna Model

The following is a transmit power table (EU domain) per external patch antenna in the 5 GHz band:

20 MHZ CHANNEL	40 MHZ CHANNEL	80 MHZ CHANNELS	LEGACY OFDM RATES (6,9,12,18,24,36,48,54 MBPS)	802.11n HT20 RATES (MCS 0 MCS 15)	802.11n HT40 RATES (MCS 0 MCS 15)	802.11n HT80 RATES (MCS 0 MCS 15)
36			14.5	14.5		
38	(36, 40)		14.5	14.5	14.5	
40			14.5	14.5		
42		(36, 40, 44, 48)	14.5	14.5		14.5
44			14.5	14.5		
46	(44, 48)		14.5	14.5	14.5	
48			14.5	14.5		
52			11.5	11.5		
54	(52, 56)		11.5	11.5	11.5	
56			11.5	11.5		
58		(52, 56, 60, 64)	11.5	11.5		11.5
60			11.5	11.5		
62	(60, 64)		11.5	11.5	11.5	
64			11.5	11.5		
100			18.0	18.0		
102	(100, 104)		18.0	18.0	18.0	
104			18.0	18.0		
106		(100, 104, 108, 112)	18.0	18.0		18.0
108			18.0	18.0		

20 MHZ CHANNEL	40 MHZ CHANNEL	80 MHZ CHANNELS	LEGACY OFDM RATES (6,9,12,18,24,36,48,54 MBPS)	802.11n HT20 RATES (MCS 0 MCS 15)	802.11n HT40 RATES (MCS 0 MCS 15)	802.11n HT80 RATES (MCS 0 MCS 15)
110			18.0	18.0	18.0	
112			18.0	18.0		
114			18.0	18.0		
116			18.0	18.0		
118	(116, 120)		18.0	18.0	18.0	
120			18.0	18.0		
122		(116, 120, 124, 128)	18.0	18.0		18.0
124			18.0	18.0		
126	(124, 128)		18.0	18.0	18.0	
128			18.0	18.0		
130			18.0	18.0		
132			18.0	18.0		
134	(132, 136)		18.0	18.0	18.0	
136			18.0	18.0		
138			18.0	18.0		
140			18.0	18.0		
142			18.0	18.0	18.0	
144			18.0	18.0		
149			18.0	18.0		
151	(149, 153)					
153						
155		(149, 153, 157, 161)				
157						
159	(157, 161)					
161						
165						

External patch antenna, peak gain = 3.8dBi

AP8232 EU Domain 5 GHz Facade Antenna Model

The following is a transmit power table (EU domain) per external facade antenna in the 5 GHz band:

20 MHZ CHANNEL	40 MHZ CHANNEL	80 MHZ CHANNELS	LEGACY OFDM RATES (6,9,12,18,24,36,48,54 MBPS)	802.11n HT20 RATES (MCS 0 MCS 15)	802.11n HT40 RATES (MCS 0 MCS 15)	802.11n HT80 RATES (MCS 0 MCS 15)
36			14.5	14.5		
38	(36, 40)		14.5	14.5	14.5	
40			14.5	14.5		
42		(36, 40, 44, 48)	14.5	14.5		14.5
44			14.5	14.5		
46	(44, 48)		14.5	14.5	14.5	
48			14.5	14.5		
52			11.5	11.5		
54	(52, 56)		11.5	11.5	11.5	
56			11.5	11.5		
58		(52, 56, 60, 64)	11.5	11.5		11.5
60			11.5	11.5		
62	(60, 64)		11.5	11.5	11.5	
64			11.5	11.5		
100			18.0	18.0		
102	(100, 104)		18.0	18.0	18.0	
104			18.0	18.0		
106		(100, 104, 108, 112)	18.0	18.0		18.0
108			18.0	18.0		
110			18.0	18.0	18.0	
112			18.0	18.0		
114			18.0	18.0		
116			18.0	18.0		
118	(116, 120)		18.0	18.0	18.0	
120			18.0	18.0		
122		(116, 120, 124, 128)	18.0	18.0		18.0
124			18.0	18.0		
126	(124, 128)		18.0	18.0	18.0	
128			18.0	18.0		
130			18.0	18.0		
132			18.0	18.0		

20 MHZ CHANNEL	40 MHZ CHANNEL	80 MHZ CHANNELS	LEGACY OFDM RATES (6,9,12,18,24,36,48,54 MBPS)	802.11n HT20 RATES (MCS 0 MCS 15)	802.11n HT40 RATES (MCS 0 MCS 15)	802.11n HT80 RATES (MCS 0 MCS 15)
134	(132, 136)		18.0	18.0	18.0	
136			18.0	18.0		
138			18.0	18.0		
140			18.0	18.0		
142			18.0	18.0	18.0	
144			18.0	18.0		
149						
151	(149, 153)					
153						
155		(149, 153, 157, 161)				
157						
159	(157, 161)					
161						
165						

Facade antenna, peak gain = 4dBi

AP8232 Japan Regulatory Domain 2.4 GHz Band

AP8232 Japan Domain 2.4 GHz External Dipole Antenna Model

The following is a transmit power table (Japanese domain) per external dipole antenna in the 2.4 GHz band:

20 MHZ CHANNEL	40 MHZ CHANNEL	LEGACY DSSS RATES (1, 2, 5.5, 11 MBPS)	LEGACY OFDM RATES (6,9,12,18,24,36,48,54 MBPS)	802.11n HT20 RATES (MCS 0 MCS 15)	802.11n HT40 RATES (MCS 0 MCS 15)
1		8.0	9.0	4.5	
2		8.0	9.0	9.0	
3	(1, 5)	8.0	9.0	9.0	9.0
4	(2, 6)	8.0	9.0	9.0	9.0
5	(3, 7)	8.0	9.0	9.0	9.0
6	(4, 8)	8.0	9.0	9.0	9.0
7	(5, 9)	8.0	9.0	9.0	9.0
8	(6, 10)	8.0	9.0	9.0	9.0

20 MHZ CHANNEL	40 MHZ CHANNEL	LEGACY DSSS RATES (1, 2, 5.5, 11 MBPS)	LEGACY OFDM RATES (6,9,12,18,24,36,48,54 MBPS)	802.11n HT20 RATES (MCS 0 MCS 15)	802.11n HT40 RATES (MCS 0 MCS15)
9	(7, 11)	8.0	9.0	9.0	9.0
10	(8, 12)	8.0	9.0	9.0	9.0
11	(9, 13)	8.0	9.0	9.0	9.0
12		8.0	9.0	9.0	
13		8.0	9.0	9.0	
14					

External dipole antenna, peak gain = 10.5dBi

AP8232 Japan Domain 2.4 GHz External Panel Antenna Model

The following is a transmit power table (Japanese domain) per external panel antenna in the 2.4 GHz band:

20 MHZ CHANNEL	40 MHZ CHANNEL	LEGACY DSSS RATES (1, 2, 5.5, 11 MBPS)	LEGACY OFDM RATES (6,9,12,18,24,36,48,54 MBPS)	802.11n HT20 RATES (MCS 0 MCS 15)	802.11n HT40 RATES (MCS 0 MCS15)
1		13.0	14.0	14.0	
2		13.0	14.0	14.0	
3	(1, 5)	13.0	14.0	14.0	14.0
4	(2, 6)	13.0	14.0	14.0	14.0
5	(3, 7)	13.0	14.0	14.0	14.0
6	(4, 8)	13.0	14.0	14.0	14.0
7	(5, 9)	13.0	14.0	14.0	14.0
8	(6, 10)	13.0	14.0	14.0	14.0
9	(7, 11)	13.0	14.0	14.0	14.0
10	(8, 12)	13.0	14.0	14.0	14.0
11	(9, 13)	13.0	14.0	14.0	14.0
12		13.0	14.0	14.0	
13		13.0	14.0	14.0	
14					

External panel antenna, peak gain = 15dBi

AP8232 Japan Domain 2.4 GHz External Yagi Antenna Model

The following is a transmit power table (Japanese domain) per external patch antenna in the 2.4 GHz band:

20 MHZ CHANNEL	40 MHZ CHANNEL	LEGACY DSSS RATES (1, 2, 5.5, 11 MBPS)	LEGACY OFDM RATES (6,9,12,18,24,36,48,54 MBPS)	802.11n HT20 RATES (MCS 0 MCS 15)	802.11n HT40 RATES (MCS 0 MCS15)
1		14.0	15.0	15.0	
2		14.0	15.0	15.0	
3	(1, 5)	14.0	15.0	15.0	15.0
4	(2, 6)	14.0	15.0	15.0	15.0
5	(3, 7)	14.0	15.0	15.0	15.0
6	(4, 8)	14.0	15.0	15.0	15.0
7	(5, 9)	14.0	15.0	15.0	15.0
8	(6, 10)	14.0	15.0	15.0	15.0
9	(7, 11)	14.0	15.0	15.0	15.0
10		14.0	15.0	15.0	
11		14.0	15.0	15.0	
12					
13					
14					

External patch antenna, peak gain = 14.5dBi

AP8232 Japan Domain 2.4 GHz External Patch Antenna Model

The following is a transmit power table (Japanese domain) per external patch antenna in the 2.4 GHz band:

20 MHZ CHANNEL	40 MHZ CHANNEL	LEGACY DSSS RATES (1, 2, 5.5, 11 MBPS)	LEGACY OFDM RATES (6,9,12,18,24,36,48,54 MBPS)	802.11n HT20 RATES (MCS 0 MCS 15)	802.11n HT40 RATES (MCS 0 MCS15)
1		14.0	15.0	15.0	
2		14.0	15.0	15.0	
3	(1, 5)	14.0	15.0	15.0	15.0
4	(2, 6)	14.0	15.0	15.0	15.0
5	(3, 7)	14.0	15.0	15.0	15.0
6	(4, 8)	14.0	15.0	15.0	15.0
7	(5, 9)	14.0	15.0	15.0	15.0

20 MHZ CHANNEL	40 MHZ CHANNEL	LEGACY DSSS RATES (1, 2, 5.5, 11 MBPS)	LEGACY OFDM RATES (6,9,12,18,24,36,48,54 MBPS)	802.11n HT20 RATES (MCS 0 MCS 15)	802.11n HT40 RATES (MCS 0 MCS15)
8	(6, 10)	14.0	15.0	15.0	15.0
9	(7, 11)	14.0	15.0	15.0	15.0
10		14.0	15.0	15.0	
11		14.0	15.0	15.0	
12					
13					
14					

External patch antenna, peak gain = 4dBi

AP8232 Japan Domain 2.4 GHz Facade Antenna Model

The following is a transmit power table (Japanese domain) per internal facade antenna in the 2.4 GHz band:

20 MHZ CHANNEL	40 MHZ CHANNEL	LEGACY DSSS RATES (1, 2, 5.5, 11 MBPS)	LEGACY OFDM RATES (6,9,12,18,24,36,48,54 MBPS)	802.11n HT20 RATES (MCS 0 MCS 15)	802.11n HT40 RATES (MCS 0 MCS15)
1		15.0	15.0	15.0	
2		15.0	15.0	15.0	
3	(1, 5)	15.0	15.0	15.0	15.0
4	(2, 6)	15.0	15.0	15.0	15.0
5	(3, 7)	15.0	15.0	15.0	15.0
6	(4, 8)	15.0	15.0	15.0	15.0
7	(5, 9)	15.0	15.0	15.0	15.0
8	(6, 10)	15.0	15.0	15.0	15.0
9	(7, 11)	15.0	15.0	15.0	15.0
10		15.0	15.0	15.0	
11		15.0	15.0	15.0	
12					
13					
14					

Facade antenna, peak gain = 3.5dBi

AP8232 Japan Regulatory Domain 5 GHz Band

AP8232 Japan Domain 5 GHz External Dipole Antenna Model

The following is a transmit power table (Japanese domain) per external dipole antenna in the 5 GHz band:

20 MHZ CHANNEL	40 MHZ CHANNEL	80 MHZ CHANNELS	LEGACY OFDM RATES (6,9,12,18,24,36,48,54 MBPS)	802.11n HT20 RATES (MCS 0 MCS 15)	802.11n HT40 RATES (MCS 0 MCS 15)	802.11n HT80 RATES (MCS 0 MCS 15)
36			7.0	7.0		
38	(36, 40)		7.0	7.0	7.0	
40			7.0	7.0		
42		(36, 40, 44, 48)	7.0	7.0		7.0
44			7.0	7.0		
46	(44, 48)		7.0	7.0	7.0	
48			7.0	7.0		
52			7.0	7.0		
54	(52, 56)		7.0	7.0	7.0	
56			7.0	7.0		
58		(52, 56, 60, 64)	7.0	7.0		7.0
60			7.0	7.0		
62	(60, 64)		7.0	7.0	7.0	
64			7.0	7.0		
100			14.0	14.0		
102	(100, 104)		14.0	14.0	14.0	
104			14.0	14.0		
106		(100, 104, 108, 112)	14.0	14.0		14.0
108			14.0	14.0		
110			14.0	14.0	14.0	
112			14.0	14.0		
114			14.0	14.0		
116			14.0	14.0		
118	(116, 120)		14.0	14.0	14.0	
120			14.0	14.0		
122		(116, 120, 124, 128)	14.0	14.0		14.0
124			14.0	14.0		
126	(124, 128)		14.0	14.0		

20 MHZ CHANNEL	40 MHZ CHANNEL	80 MHZ CHANNELS	LEGACY OFDM RATES (6,9,12,18,24,36,48,54 MBPS)	802.11n HT20 RATES (MCS 0 MCS 15)	802.11n HT40 RATES (MCS 0 MCS 15)	802.11n HT80 RATES (MCS 0 MCS 15)
128			14.0	14.0		
130			14.0	14.0		
132			14.0	14.0		
134	(132, 136)		14.0	14.0	14.0	
136			14.0	14.0		
138			14.0	14.0		
140			14.0	14.0		
142			14.0	14.0	14.0	
144			14.0	14.0		
149						
151	(149, 153)					
153						
155		(149, 153, 157, 161)				
157						
159	(157, 161)					
161						
165						

External dipole antenna, peak gain = 10.5dBi

AP8232 Japan Domain 5 GHz External Panel Antenna Model

The following is a transmit power table (Japanese domain) per external panel antenna in the 5 GHz band:

20 MHZ CHANNEL	40 MHZ CHANNEL	80 MHZ CHANNELS	LEGACY OFDM RATES (6,9,12,18,24,36,48,54 MBPS)	802.11n HT20 RATES (MCS 0 MCS 15)	802.11n HT40 RATES (MCS 0 MCS 15)	802.11n HT80 RATES (MCS 0 MCS 15)
36			3.0	3.0		
38	(36, 40)		3.0	3.0	3.0	
40			3.0	3.0		
42		(36, 40, 44, 48)	3.0	3.0		3.0
44			3.0	3.0		
46	(44, 48)		3.0	3.0	3.0	

20 MHZ CHANNEL	40 MHZ CHANNEL	80 MHZ CHANNELS	LEGACY OFDM RATES (6,9,12,18,24,36,48,54 MBPS)	802.11n HT20 RATES (MCS 0 MCS 15)	802.11n HT40 RATES (MCS 0 MCS 15)	802.11n HT80 RATES (MCS 0 MCS 15)
48			3.0	3.0		
52			3.0	3.0		
54	(52, 56)		3.0	3.0	3.0	3.0
56			3.0	3.0		
58		(52, 56, 60, 64)	3.0	3.0		3.0
60			3.0	3.0		
62	(60, 64)		3.0	3.0	3.0	
64			3.0	3.0		
100			10.0	10.0		
102	(100, 104)		10.0	10.0	10.0	
104			10.0	10.0		
106		(100, 104, 108, 112)	10.0	10.0		10.0
108			10.0	10.0		
110			10.0	10.0	10.0	
112			10.0	10.0		
114			10.0	10.0		
116			10.0	10.0		
118	(116, 120)		10.0	10.0	10.0	
120			10.0	10.0		
122		(116, 120, 124, 128)	10.0	10.0		10.0
124			10.0	10.0		
126	(124, 128)		10.0	10.0	10.0	
128			10.0	10.0		
130			10.0	10.0		
132			10.0	10.0		
134	(132, 136)		10.0	10.0	10.0	
136			10.0	10.0		
138			10.0	10.0		
140			10.0	10.0		
142			10.0	10.0	10.0	
144			10.0	10.0		
149						

20 MHZ CHANNEL	40 MHZ CHANNEL	80 MHZ CHANNELS	LEGACY OFDM RATES (6,9,12,18,24,36,48,54 MBPS)	802.11n HT20 RATES (MCS 0 MCS 15)	802.11n HT40 RATES (MCS 0 MCS 15)	802.11n HT80 RATES (MCS 0 MCS 15)
151	(149, 153)					
153						
155		(149, 153, 157, 161)				
157						
159	(157, 161)					
161						
165						

External panel antenna, peak gain = 14dBi

AP8232 Japan Domain 5 GHz External Yagi Antenna Model

The following is a transmit power table (Japanese domain) per external yagi antenna in the 5 GHz band:

20 MHZ CHANNEL	40 MHZ CHANNEL	80 MHZ CHANNELS	LEGACY OFDM RATES (6,9,12,18,24,36,48,54 MBPS)	802.11n HT20 RATES (MCS 0 MCS 15)	802.11n HT40 RATES (MCS 0 MCS 15)	802.11n HT80 RATES (MCS 0 MCS 15)
36			7.0	7.0		
38	(36, 40)		7.0	7.0	7.0	
40			7.0	7.0		
42		(36, 40, 44, 48)	7.0	7.0		7.0
44			7.0	7.0		
46	(44, 48)		7.0	7.0	7.0	
48			7.0	7.0		
52			7.0	7.0		
54	(52, 56)		7.0	7.0	7.0	
56			7.0	7.0		
58		(52, 56, 60, 64)	7.0	7.0		7.0
60			7.0	7.0		
62	(60, 64)		7.0	7.0	7.0	
64			7.0	7.0		
100			14.0	14.0		
102	(100, 104)		14.0	14.0	14.0	

20 MHZ CHANNEL	40 MHZ CHANNEL	80 MHZ CHANNELS	LEGACY OFDM RATES (6,9,12,18,24,36,48,54 MBPS)	802.11n HT20 RATES (MCS 0 MCS 15)	802.11n HT40 RATES (MCS 0 MCS 15)	802.11n HT80 RATES (MCS 0 MCS 15)
104			14.0	14.0		
106		(100, 104, 108, 112)	14.0	14.0		14.0
108			14.0	14.0		
110			14.0	14.0	14.0	
112			14.0	14.0		
114			14.0	14.0		
116			14.0	14.0		
118	(116, 120)		14.0	14.0	14.0	
120			14.0	14.0		
122		(116, 120, 124, 128)	14.0	14.0		14.0
124			14.0	14.0		
126	(124, 128)		14.0	14.0	14.0	
128			14.0	14.0		
130			14.0	14.0		
132			14.0	14.0		
134	(132, 136)		14.0	14.0	14.0	
136			14.0	14.0		
138			14.0	14.0		
140			14.0	14.0		
142			14.0	14.0	14.0	
144			14.0	14.0		
149						
151	(149, 153)					
153						
155		(149, 153, 157, 161)				
157						
159	(157, 161)					
161						
165						

External yagi antenna, peak gain = 10.5dBi

AP8232 Japan Domain 5 GHz External Patch Antenna Model

The following is a transmit power table (Japanese domain) per external patch antenna in the 5 GHz band:

20 MHZ CHANNEL	40 MHZ CHANNEL	80 MHZ CHANNELS	LEGACY OFDM RATES (6,9,12,18,24,36,48,54 MBPS)	802.11n HT20 RATES (MCS 0 MCS 15)	802.11n HT40 RATES (MCS 0 MCS 15)	802.11n HT80 RATES (MCS 0 MCS 15)
36			13.0	13.0		
38	(36, 40)		13.0	13.0	13.0	
40			13.0	13.0		
42		(36, 40, 44, 48)	13.0	13.0		13.0
44			13.0	13.0		
46	(44, 48)		13.0	13.0	13.0	
48			13.0	13.0		
52			13.0	13.0		
54	(52, 56)		13.0	13.0	13.0	
56			13.0	13.0		
58		(52, 56, 60, 64)	13.0	13.0		13.0
60			13.0	13.0		
62	(60, 64)		13.0	13.0	13.0	
64			13.0	13.0		
100			20.0	20.0		
102	(100, 104)		20.0	20.0	20.0	
104			20.0	20.0		
106		(100, 104, 108, 112)	20.0	20.0		20.0
108			20.0	20.0		
110			20.0	20.0	20.0	
112			20.0	20.0		
114			20.0	20.0		
116			20.0	20.0		
118	(116, 120)		20.0	20.0	20.0	
120			20.0	20.0		
122		(116, 120, 124, 128)	20.0	20.0		20.0
124			20.0	20.0		
126	(124, 128)		20.0	20.0	20.0	

20 MHZ CHANNEL	40 MHZ CHANNEL	80 MHZ CHANNELS	LEGACY OFDM RATES (6,9,12,18,24,36,48,54 MBPS)	802.11n HT20 RATES (MCS 0 MCS 15)	802.11n HT40 RATES (MCS 0 MCS 15)	802.11n HT80 RATES (MCS 0 MCS 15)
128			20.0	20.0		
130			20.0	20.0		
132			20.0	20.0		
134	(132, 136)		20.0	20.0	20.0	
136			20.0	20.0		
138			20.0	20.0		
140			20.0	20.0		
142			20.0	20.0	20.0	
144			20.0	20.0		
149			20.0	20.0		
151	(149, 153)					
153						
155		(149, 153, 157, 161)				
157						
159	(157, 161)					
161						
165						

External patch antenna, peak gain = 3.8dBi

AP8232 Japan Domain 5 GHz Facade Antenna Model

The following is a transmit power table (Japanese domain) per external facade antenna in the 5 GHz band:

20 MHZ CHANNEL	40 MHZ CHANNEL	80 MHZ CHANNELS	LEGACY OFDM RATES (6,9,12,18,24,36,48,54 MBPS)	802.11n HT20 RATES (MCS 0 MCS 15)	802.11n HT40 RATES (MCS 0 MCS 15)	802.11n HT80 RATES (MCS 0 MCS 15)
36			13.0	13.0		
38	(36, 40)		13.0	13.0	13.0	
40			13.0	13.0		
42		(36, 40, 44, 48)	13.0	13.0		13.0
44			13.0	13.0		
46	(44, 48)		13.0	13.0	13.0	

20 MHZ CHANNEL	40 MHZ CHANNEL	80 MHZ CHANNELS	LEGACY OFDM RATES (6,9,12,18,24,36,48,54 MBPS)	802.11n HT20 RATES (MCS 0 MCS 15)	802.11n HT40 RATES (MCS 0 MCS 15)	802.11n HT80 RATES (MCS 0 MCS 15)
48			13.0	13.0		
52			13.0	13.0		
54	(52, 56)		13.0	13.0	13.0	
56			13.0	13.0		
58		(52, 56, 60, 64)	13.0	13.0		13.0
60			13.0	13.0		
62	(60, 64)		13.0	13.0	13.0	
64			13.0	13.0		
100			20.0	20.0		
102	(100, 104)		20.0	20.0	20.0	
104			20.0	20.0		
106		(100, 104, 108, 112)	20.0	20.0		20.0
108			20.0	20.0		
110			20.0	20.0	20.0	
112			20.0	20.0		
114			20.0	20.0		
116			20.0	20.0		
118	(116, 120)		20.0	20.0	20.0	
120			20.0	20.0		
122		(116, 120, 124, 128)	20.0	20.0		20.0
124			20.0	20.0		
126	(124, 128)		20.0	20.0	20.0	
128			20.0	20.0		
130			20.0	20.0		
132			20.0	20.0		
134	(132, 136)		20.0	20.0	20.0	
136			20.0	20.0		
138			20.0	20.0		
140			20.0	20.0		
142			20.0	20.0	20.0	
144			20.0	20.0		
149						

20 MHZ CHANNEL	40 MHZ CHANNEL	80 MHZ CHANNELS	LEGACY OFDM RATES (6,9,12,18,24,36,48,54 MBPS)	802.11n HT20 RATES (MCS 0 MCS 15)	802.11n HT40 RATES (MCS 0 MCS 15)	802.11n HT80 RATES (MCS 0 MCS 15)
151	(149, 153)					
153						
155		(149, 153, 157, 161)				
157						
159	(157, 161)					
161						
165						

Facade antenna, peak gain = 4dBi

21 AP8222 Regulatory Domains

AP8222 US Regulatory Domain 2.4 GHz Band
 AP8222 US Regulatory Domain 5 GHz Band
 AP8222 EU Regulatory Domain 2.4 GHz Band
 AP8222 EU Regulatory Domain 5 GHz Band
 AP8222 Japan Regulatory Domain 2.4 GHz Band
 AP8222 Japan Regulatory Domain 5 GHz Band

AP8222 US Regulatory Domain 2.4 GHz Band

AP8222 US Domain 2.4 GHz Internal Antenna Maximum Conducted Transmit Power Settings

The following is a transmit power table (US domain) per internal antenna in the 2.4 GHz band:

20 MHZ CHANNEL	40 MHZ CHANNEL	LEGACY DSSS RATES (1, 2, 5.5, 11 MBPS)	LEGACY OFDM RATES (6,9,12,18,24,36,48,54 MBPS)	802.11n HT20 RATES (MCS 0 MCS 15)	802.11n HT40 RATES (MCS 0 MCS15)
1		22.5	18.5	15.0	
2		22.0	18.5	15.0	
3	(1, 5)	22.0	23.0	15.0	11.0
4	(2, 6)	22.0	23.0	15.0	11.0
5	(3, 7)	22.0	23.0	15.0	15.0
6	(4, 8)	22.0	23.0	15.0	15.0
7	(5, 9)	22.0	23.0	15.0	15.0
8	(6, 10)	22.0	23.0	15.0	12.0
9	(7, 11)	22.0	23.0	15.0	12.0
10		22.0	17.5	15.0	
11		22.0	17.5	14.0	

Internal antenna, peak gain = 4.3dBi

AP8222 US Regulatory Domain 5 GHz Band

AP8222 US Domain 5 GHz Internal Antenna Model

The following is a transmit power table (US domain) per internal antenna (3x3 mode) in the 5 GHz band:

20 MHZ CHANNEL	40 MHZ CHANNEL	80 MHZ CHANNELS	LEGACY OFDM RATES (6,9,12,18,24,36,48,54 MBPS)	802.11n HT20 RATES (MCS 0 MCS 15)	802.11n HT40 RATES (MCS 0 MCS 15)	802.11n HT80 RATES (MCS 0 MCS 15)
36			9.0	13.0		
38	(36, 40)		9.0	13.0	13.0	
40			9.0	13.0		
42		(36, 40, 44, 48)	9.0	13.0		13.0
44			9.0	13.0		
46	(44, 48)		9.0	13.0	13.0	
48			9.0	13.0		
52			17.0	17.0		
54	(52, 56)		17.0	17.0	17.0	
56			17.0	17.0		
58		(52, 56, 60, 64)	17.0	17.0		12.0
60			17.0	17.0		
62	(60, 64)		17.0	17.0	15.0	
64			17.0	17.0		
100			9.0	13.0		
102	(100, 104)		9.0	13.0	15.5	
104			9.0	13.0		
106		(100, 104, 108, 112)	17.0	17.0		9.0
108			17.0	17.0		
110			17.0	17.0	17.0	
112			17.0	17.0		
114			17.0	17.0		
116			17.0	17.0		
118	(116, 120)		17.0	17.0	17.0	
120			17.0	17.0		
122		(116, 120, 124, 128)	17.0	17.0		
124			17.0	17.0		
126	(124, 128)		17.0	17.0	17.0	

20 MHZ CHANNEL	40 MHZ CHANNEL	80 MHZ CHANNELS	LEGACY OFDM RATES (6,9,12,18,24,36,48,54 MBPS)	802.11n HT20 RATES (MCS 0 MCS 15)	802.11n HT40 RATES (MCS 0 MCS 15)	802.11n HT80 RATES (MCS 0 MCS 15)
128			17.0	17.0		
130			17.0	17.0		
132			17.0	17.0		
134	(132, 136)		17.0	17.0	17.0	
136			17.0	17.0		
138			17.0	17.0		
140			9.0	13.0		
142			9.0	13.0	17.0	
144			9.0	13.0		
149			20.0	20.0		
151	(149, 153)		20.0	20.0	20.0	
153			20.0	20.0		
155		(149, 153, 157, 161)	20.0	20.0		20.0
157			20.0	20.0		
159	(157, 161)		20.0	20.0	20.0	
161			20.0	20.0		
165			20.0	20.0		

External dipole antenna, peak gain = 5.3dBi

AP8222 EU Regulatory Domain 2.4 GHz Band

AP8222 EU Domain 2.4 GHz Internal Antenna Maximum Conducted Transmit Power Settings

The following is a transmit power table (EU domain) per internal antenna in the 2.4 GHz band:

20 MHZ CHANNEL	40 MHZ CHANNEL	LEGACY DSSS RATES (1, 2, 5.5, 11 MBPS)	LEGACY OFDM RATES (6,9,12,18,24,36,48,54 MBPS)	802.11n HT20 RATES (MCS 0 MCS 15)	802.11n HT40 RATES (MCS 0 MCS 15)
1		11.0	11.0	11.0	
2		11.0	11.0	11.0	
3	(1, 5)	11.0	11.0	11.0	11.0
4	(2, 6)	11.0	11.0	11.0	11.0
5	(3, 7)	11.0	11.0	11.0	11.0

20 MHZ CHANNEL	40 MHZ CHANNEL	LEGACY DSSS RATES (1, 2, 5.5, 11 MBPS)	LEGACY OFDM RATES (6,9,12,18,24,36,48,54 MBPS)	802.11n HT20 RATES (MCS 0 MCS 15)	802.11n HT40 RATES (MCS 0 MCS15)
6	(4, 8)	11.0	11.0	11.0	11.0
7	(5, 9)	11.0	11.0	11.0	11.0
8	(6, 10)	11.0	11.0	11.0	11.0
9	(7, 11)	11.0	11.0	11.0	11.0
10		11.0	11.0	11.0	11.0
11		11.0	11.0	11.0	11.0
12		11.0	11.0	11.0	
13		11.0	11.0	11.0	
14					

Internal antenna, peak gain = 4.3dBi

AP8222 EU Regulatory Domain 5 GHz Band

AP8222 EU Domain 5 GHz Internal Antenna Model

The following is a transmit power table (EU domain) per internal antenna (3x3 mode) in the 5 GHz band:

20 MHZ CHANNEL	40 MHZ CHANNEL	80 MHZ CHANNELS	LEGACY OFDM RATES (6,9,12,18,24,36,48,54 MBPS)	802.11n HT20 RATES (MCS 0 MCS 15)	802.11n HT40 RATES (MCS 0 MCS 15)	802.11n HT80RATES (MCS 0 MCS 15)
36			12.0	12.0		
38	(36, 40)		12.0	12.0	12.0	
40			12.0	12.0		
42		(36, 40, 44, 48)	12.0	12.0		12.0
44			12.0	12.0		
46	(44, 48)		12.0	12.0	12.0	
48			12.0	12.0		
52			10.0	10.0		
54	(52, 56)		10.0	10.0	10.0	
56			10.0	10.0		
58		(52, 56, 60, 64)	10.0	10.0		10.0
60			10.0	10.0		

20 MHZ CHANNEL	40 MHZ CHANNEL	80 MHZ CHANNELS	LEGACY OFDM RATES (6,9,12,18,24,36,48,54 MBPS)	802.11n HT20 RATES (MCS 0 MCS 15)	802.11n HT40 RATES (MCS 0 MCS 15)	802.11n HT80 RATES (MCS 0 MCS 15)
62	(60, 64)		10.0	10.0	10.0	
64			10.0	10.0		
100			17.0	17.0		
102	(100, 104)		17.0	17.0	17.0	
104			17.0	17.0		
106		(100, 104, 108, 112)	17.0	17.0		17.0
108			17.0	17.0		
110			17.0	17.0		
112			17.0	17.0		
114			17.0	17.0		
116			17.0	17.0		
118	(116, 120)		17.0	17.0	17.0	
120			17.0	17.0		
122		(116, 120, 124, 128)	17.0	17.0		17.0
124			17.0	17.0		
126	(124, 128)		17.0	17.0	17.0	
128			17.0	17.0		
130			17.0	17.0		
132			17.0	17.0		
134	(132, 136)		17.0	17.0	17.0	
136			17.0	17.0		
138			17.0	17.0		
140			17.0	17.0		
142			17.0	17.0	17.0	
144			17.0	17.0		
149						
151	(149, 153)					
153						
155		(149, 153, 157, 161)				
157						
159	(157, 161)					

20 MHZ CHANNEL	40 MHZ CHANNEL	80 MHZ CHANNELS	LEGACY OFDM RATES (6,9,12,18,24,36,48,54 MBPS)	802.11n HT20 RATES (MCS 0 MCS 15)	802.11n HT40 RATES (MCS 0 MCS 15)	802.11n HT80 RATES (MCS 0 MCS 15)
161						
165						

External dipole antenna, peak gain = 5.3dBi

AP8222 Japan Regulatory Domain 2.4 GHz Band

AP8222 Japan Domain 2.4 GHz Internal Antenna Maximum Conducted Transmit Power Settings

The following is a transmit power table (Japanese domain) per internal antenna in the 2.4 GHz band:

20 MHZ CHANNEL	40 MHZ CHANNEL	LEGACY DSSS RATES (1, 2, 5.5, 11 MBPS)	LEGACY OFDM RATES (6,9,12,18,24,36,48,54 MBPS)	802.11n HT20 RATES (MCS 0 MCS 15)	802.11n HT40 RATES (MCS 0 MCS 15)
1		13.0	16.0	16.0	
2		13.0	16.0	16.0	
3	(1, 5)	13.0	16.0	16.0	15.0
4	(2, 6)	13.0	16.0	16.0	15.0
5	(3, 7)	13.0	16.0	16.0	15.0
6	(4, 8)	13.0	16.0	16.0	15.0
7	(5, 9)	13.0	16.0	16.0	15.0
8	(6, 10)	13.0	16.0	16.0	15.0
9	(7, 11)	13.0	16.0	16.0	15.0
10		13.0	16.0	16.0	15.0
11		13.0	16.0	16.0	15.0
12		13.0	16.0	16.0	
13		13.0	16.0	16.0	
14					

Internal antenna, peak gain = 4.3dBi

AP8222 Japan Regulatory Domain 5 GHz Band

AP8222 Japan Domain 5 GHz Internal Antenna Model

The following is a transmit power table (Japanese domain) per internal antenna (3x3 mode) in the 5 GHz band:

20 MHZ CHANNEL	40 MHZ CHANNEL	80 MHZ CHANNELS	LEGACY OFDM RATES (6,9,12,18,24,36,48,54 MBPS)	802.11n HT20 RATES (MCS 0 MCS 15)	802.11n HT40 RATES (MCS 0 MCS 15)	802.11n HT80 RATES (MCS 0 MCS 15)
36			13.0	13.0		
38	(36, 40)		13.0	13.0	13.0	
40			13.0	13.0		
42		(36, 40, 44, 48)	13.0	13.0		13.0
44			13.0	13.0		
46	(44, 48)		13.0	13.0	13.0	
48			13.0	13.0		
52			13.0	13.0		
54	(52, 56)		13.0	13.0	13.0	
56			13.0	13.0		
58		(52, 56, 60, 64)	13.0	13.0		13.0
60			13.0	13.0		
62	(60, 64)		13.0	13.0	13.0	
64			13.0	13.0		
100			20.0	20.0		
102	(100, 104)		20.0	20.0	20.0	
104			20.0	20.0		
106		(100, 104, 108, 112)	20.0	20.0		20.0
108			20.0	20.0		
110			20.0	20.0		
112			20.0	20.0		
114			20.0	20.0		
116			20.0	20.0		
118	(116, 120)		20.0	20.0	20.0	
120			20.0	20.0		
122		(116, 120, 124, 128)	20.0	20.0		20.0
124			20.0	20.0		
126	(124, 128)		20.0	20.0	20.0	

20 MHZ CHANNEL	40 MHZ CHANNEL	80 MHZ CHANNELS	LEGACY OFDM RATES (6,9,12,18,24,36,48,54 MBPS)	802.11n HT20 RATES (MCS 0 MCS 15)	802.11n HT40 RATES (MCS 0 MCS 15)	802.11n HT80 RATES (MCS 0 MCS 15)
128			20.0	20.0		
130			20.0	20.0		
132			20.0	20.0		
134	(132, 136)		20.0	20.0	20.0	
136			20.0	20.0		
138			20.0	20.0		
140			20.0	20.0		
142			20.0	20.0	20.0	
144			20.0	20.0		
149						
151	(149, 153)					
153						
155		(149, 153, 157, 161)				
157						
159	(157, 161)					
161						
165						

External dipole antenna, peak gain = 5.3dBi

22 AP7532 Regulatory Domains

AP7532 US Regulatory Domain 2.4 GHz Band
 AP7532 US Regulatory Domain 5 GHz Band
 AP7532 EU Regulatory Domain 2.4 GHz Band
 AP7532 EU Regulatory Domain 5 GHz Band
 AP7532 Japan Regulatory Domain 2.4 GHz Band
 AP7532 Japan Regulatory Domain 5 GHz Band
 AP7532 NCC Domain

AP7532 US Regulatory Domain 2.4 GHz Band

AP7532 US Domain 2.4 GHz External Dipole Antenna Maximum Conducted Transmit Power Settings

The following is a transmit power table (US domain) per external dipole antenna in the 2.4 GHz band:

20 MHZ CHANNEL	40 MHZ CHANNEL	LEGACY DSSS RATES (1TX)	LEGACY OFDM RATES (1TX)	802.11n HT20 RATES/TURBO QAM (3TX)	802.11n HT40 RATES/TURBO QAM (3TX)
1		20.0	16.0	16.0	
2		20.0	20.0	20.0	
3	(1, 5)	20.0	20.0	20.0	13.0
4	(2, 6)	20.0	20.0	20.0	16.0
5	(3, 7)	20.0	20.0	20.0	16.0
6	(4, 8)	20.0	20.0	20.0	16.0
7	(5, 9)	20.0	20.0	20.0	16.0
8	(6, 10)	20.0	20.0	20.0	16.0
9	(7, 11)	20.0	20.0	20.0	15.0
10		20.0	20.0	20.0	
11		20.0	16.0	16.0	

External dipole antenna, peak gain = 3.17dBi

AP7532 US Domain 2.4 GHz External Panel Antenna Maximum Conducted Transmit Power Settings

The following is a transmit power table (US domain) per external panel antenna in the 2.4 GHz band:

20 MHZ CHANNEL	40 MHZ CHANNEL	LEGACY DSSS RATES (1TX)	LEGACY OFDM RATES (1TX)	802.11n HT20 RATES/TURBO QAM (3TX)	802.11n HT40 RATES/TURBO QAM (3TX)
1		19.0	15.0	15.0	
2		20.0	20.0	20.0	
3	(1, 5)	20.0	20.0	20.0	13.0
4	(2, 6)	20.0	20.0	20.0	14.0
5	(3, 7)	20.0	20.0	20.0	14.0
6	(4, 8)	20.0	20.0	20.0	14.0
7	(5, 9)	20.0	20.0	20.0	14.0
8	(6, 10)	20.0	20.0	20.0	14.0
9	(7, 11)	20.0	20.0	20.0	12.0
10		20.0	20.0	20.0	
11		19.0	16.0	15.0	

**Note**

The use of this panel antenna requires 1ft cable between the AP and the antenna element. If the antenna gain is 4.8dB or less, the cable is not required.

External Panel antenna, peak gain = 5.5dBi

AP7532 US Domain 2.4 GHz Internal Antenna Maximum Conducted Transmit Power Settings

The following is a transmit power table (US domain) per internal antenna in the 2.4 GHz band:

20 MHZ CHANNEL	40 MHZ CHANNEL	LEGACY DSSS RATES (1TX)	LEGACY OFDM RATES (1TX)	802.11n HT20 RATES/TURBO QAM (3TX)	802.11n HT40 RATES/TURBO QAM (3TX)
1		20.0	15.0	14.0	
2		19.0	20.0	19.0	
3	(1, 5)	19.0	20.0	19.0	10.0
4	(2, 6)	19.0	20.0	19.0	15.0
5	(3, 7)	19.0	20.0	19.0	15.0
6	(4, 8)	19.0	20.0	19.0	15.0
7	(5, 9)	19.0	20.0	19.0	15.0
8	(6, 10)	19.0	20.0	19.0	15.0
9	(7, 11)	19.0	20.0	19.0	13.0
10		19.0	20.0	19.0	
11		18.0	17.0	18.0	

Internal antenna, peak gain = 4.13dBi

AP7532 US Domain 2.4 GHz Polarized-Panel Antenna Maximum Conducted Transmit Power Settings

The following is a transmit power table (US domain) per polarized-panel antenna in the 2.4 GHz band:

20 MHZ CHANNEL	40 MHZ CHANNEL	LEGACY DSSS RATES (1TX)	LEGACY OFDM RATES (1TX)	802.11n HT20 RATES/TURBO QAM (3TX)	802.11n HT40 RATES/TURBO QAM (3TX)
1		20.0	16.0	13.0	
2		20.0	20.0	20.0	
3	(1, 5)	20.0	20.0	20.0	12.0
4	(2, 6)	20.0	20.0	20.0	14.0
5	(3, 7)	20.0	20.0	20.0	14.0
6	(4, 8)	20.0	20.0	20.0	14.0
7	(5, 9)	20.0	20.0	20.0	14.0
8	(6, 10)	20.0	20.0	20.0	14.0
9	(7, 11)	20.0	20.0	20.0	12.0
10		20.0	20.0	20.0	
11		20.0	17.0	12.0	

Polarized-panel antenna, peak gain = 6dBi

AP7532 US Domain 2.4 GHz Patch Antenna Maximum Conducted Transmit Power Settings

The following is a transmit power table (US domain) per patch antenna in the 2.4 GHz band:

20 MHZ CHANNEL	40 MHZ CHANNEL	LEGACY DSSS RATES (1TX)	LEGACY OFDM RATES (1TX)	802.11n HT20 RATES/TURBO QAM (3TX)	802.11n HT40 RATES/TURBO QAM (3TX)
1		20.0	17.0	14.0	
2		20.0	20.0	20.0	
3	(1, 5)	20.0	20.0	20.0	13.0
4	(2, 6)	20.0	20.0	20.0	14.0
5	(3, 7)	20.0	20.0	20.0	14.0
6	(4, 8)	20.0	20.0	20.0	14.0
7	(5, 9)	20.0	20.0	20.0	14.0
8	(6, 10)	20.0	20.0	20.0	14.0
9	(7, 11)	20.0	20.0	20.0	13.0

20 MHZ CHANNEL	40 MHZ CHANNEL	LEGACY DSSS RATES (1TX)	LEGACY OFDM RATES (1TX)	802.11n HT20 RATES/TURBO QAM (3TX)	802.11n HT40 RATES/TURBO QAM (3TX)
10		20.0	20.0	20.0	
11		20.0	17.0	15.0	

Internal antenna, peak gain = 5dBi

AP7532 US Regulatory Domain 5 GHz Band

AP7532 US Domain 5 GHz External Dipole Antenna Model

The following is a transmit power table (US domain) per external dipole antenna in the 5 GHz band:

20 MHZ CHANNEL	40 MHZ CHANNEL	80 MHZ CHANNELS	LEGACY OFDM RATES (1TX)	802.11n HT20 RATES (3TX)	802.11n HT40 RATES (3TX)	802.11n HT80 RATES (3TX)
36			19.0	17.0		
38	(36, 40)		20.0	16.0	17.0	
40			20.0	16.0		
42		(36, 40, 44, 48)	20.0	16.0		12.0
44			20.0	16.0		
46	(44, 48)		20.0	16.0	17.0	
48			20.0	16.0		
52			19.0	18.0		
54	(52, 56)		19.0	18.0	20.0	
56			20.0	18.0		
58		(52, 56, 60, 64)	20.0	18.0		12.0
60			20.0	18.0		
62	(60, 64)		20.0	18.0	20.0	
64			19.0	17.0		
100			18.0	17.0		
102	(100, 104)		20.0	18.0	15.0	
104			20.0	18.0		
106		(100, 104, 108, 112)	20.0	18.0		15.0
108			20.0	18.0		
110			20.0	18.0	18.0	
112			20.0	18.0		

20 MHZ CHANNEL	40 MHZ CHANNEL	80 MHZ CHANNELS	LEGACY OFDM RATES (1TX)	802.11n HT20 RATES (3TX)	802.11n HT40 RATES (3TX)	802.11n HT80 RATES (3TX)
114			20.0	18.0		
116			20.0	18.0		
118	(116, 120)		20.0	18.0	18.0	
120			20.0	18.0		
122		(116, 120, 124, 128)	20.0	18.0		20.0
124			20.0	18.0		
126	(124, 128)		20.0	18.0	18.0	
128			20.0	18.0		
130			20.0	18.0		
132			20.0	18.0		
134	(132, 136)		20.0	18.0	17.0	
136			20.0	18.0		
138			20.0	18.0		
140			16.0	16.0		
142			16.0	16.0	20.0	
144			20.0	18.0		
149			16.0	16.0		
151	(149, 153)		20.0	16.0	13.0	
153			20.0	16.0		
155		(149, 153, 157, 161)	20.0	16.0		12.0
157			20.0	16.0		
159	(157, 161)		20.0	16.0	15.0	
161			20.0	16.0		
165			17.0	16.0		

External dipole antenna, peak gain = 5dBi

AP7532 US Domain 5 GHz External Panel Antenna Model

The following is a transmit power table (US domain) per external panel antenna in the 5 GHz band:

20 MHZ CHANNEL	40 MHZ CHANNEL	80 MHZ CHANNELS	LEGACY OFDM RATES (1TX)	802.11n HT20 RATES (3TX)	802.11n HT40 RATES (3TX)	802.11n HT80 RATES (3TX)
36			19.0	18.0		
38	(36, 40)		20.0	20.0	17.0	

20 MHZ CHANNEL	40 MHZ CHANNEL	80 MHZ CHANNELS	LEGACY OFDM RATES (1TX)	802.11n HT20 RATES (3TX)	802.11n HT40 RATES (3TX)	802.11n HT80 RATES (3TX)
40			20.0	20.0		
42		(36, 40, 44, 48)	20.0	20.0		14.0
44			20.0	20.0		
46	(44, 48)		20.0	16.0	17.0	
48			20.0	16.0		
52			20.0	18.0		
54	(52, 56)		20.0	18.0	18.0	
56			20.0	17.0		
58		(52, 56, 60, 64)	20.0	17.0		15.0
60			20.0	17.0		
62	(60, 64)		20.0	17.0	18.0	
64			19.0	16.0		
100			19.0	16.0		
102	(100, 104)		20.0	17.0	18.0	
104			20.0	18.0		
106		(100, 104, 108, 112)	20.0	18.0		15.0
108			20.0	18.0		
110			20.0	18.0	18.0	
112			20.0	18.0		
114			20.0	18.0		
116			20.0	18.0		
118	(116, 120)		20.0	18.0	18.0	
120			20.0	18.0		
122		(116, 120, 124, 128)	20.0	18.0		19.0
124			20.0	18.0		
126	(124, 128)		20.0	18.0	18.0	
128			20.0	18.0		
130			20.0	18.0		
132			20.0	18.0		
134	(132, 136)		20.0	18.0	18.0	
136			20.0	18.0		
138			20.0	18.0		

20 MHZ CHANNEL	40 MHZ CHANNEL	80 MHZ CHANNELS	LEGACY OFDM RATES (1TX)	802.11n HT20 RATES (3TX)	802.11n HT40 RATES (3TX)	802.11n HT80 RATES (3TX)
140			18.0	15.0		
142			18.0	15.0	19.0	
144			20.0	18.0		
149			18.0	15.0		
151	(149, 153)		20.0	20.0	15.0	
153			20.0	20.0		
155		(149, 153, 157, 161)	20.0	20.0		15.0
157			20.0	20.0		
159	(157, 161)		20.0	20.0	15.0	
161			20.0	20.0		
165			19.0	16.0		

**Note**

The use of this panel antenna requires 1ft cable between the AP and the antenna element. If the antenna gain is 4.8dB or less, the cable is not required.

External panel antenna, peak gain = 6dBi

AP7532 US Domain 5 GHz Internal Antenna Model

The following is a transmit power table (US domain) per internal antenna in the 5 GHz band:

20 MHZ CHANNEL	40 MHZ CHANNEL	80 MHZ CHANNELS	LEGACY OFDM RATES (1TX)	802.11n HT20 RATES (3TX)	802.11n HT40 RATES (3TX)	802.11n HT80 RATES (3TX)
36			19.0	17.0		
38	(36, 40)		20.0	16.0	17.0	
40			20.0	16.0		
42		(36, 40, 44, 48)	20.0	16.0		12.0
44			20.0	16.0		
46	(44, 48)		20.0	16.0	17.0	
48			20.0	16.0		
52			20.0	14.0		
54	(52, 56)		20.0	14.0	17.0	
56			20.0	14.0		
58		(52, 56, 60, 64)	20.0	14.0		12.0

20 MHZ CHANNEL	40 MHZ CHANNEL	80 MHZ CHANNELS	LEGACY OFDM RATES (1TX)	802.11n HT20 RATES (3TX)	802.11n HT40 RATES (3TX)	802.11n HT80 RATES (3TX)
60			20.0	14.0		
62	(60, 64)		20.0	14.0	17.0	
64			18.0	14.0		
100			17.0	14.0		
102	(100, 104)		20.0	14.0	13.0	
104			20.0	14.0		
106		(100, 104, 108, 112)	20.0	14.0		13.0
108			20.0	14.0		
110			20.0	14.0	15.0	
112			20.0	14.0		
114			20.0	14.0		
116			20.0	14.0		
118	(116, 120)		20.0	14.0	15.0	
120			20.0	14.0		
122		(116, 120, 124, 128)	20.0	14.0		18.0
124			20.0	14.0		
126	(124, 128)		20.0	14.0	15.0	
128			20.0	14.0		
130			20.0	14.0		
132			20.0	14.0		
134	(132, 136)		20.0	14.0	15.0	
136			20.0	14.0		
138			20.0	14.0		
140			16.0	15.0		
142			16.0	15.0	18.0	
144			20.0	15.0		
149			16.0	16.0		
151	(149, 153)		20.0	16.0	13.0	
153			20.0	16.0		
155		(149, 153, 157, 161)	20.0	16.0		12.0
157			20.0	16.0		
159	(157, 161)		20.0	16.0	15.0	

20 MHZ CHANNEL	40 MHZ CHANNEL	80 MHZ CHANNELS	LEGACY OFDM RATES (1TX)	802.11n HT20 RATES (3TX)	802.11n HT40 RATES (3TX)	802.11n HT80 RATES (3TX)
161			20.0	16.0		
165			17.0	16.0		

Internal antenna, peak gain = 5.92dBi

AP7532 US Domain 5 GHz Polarized-Panel Antenna Model

The following is a transmit power table (US domain) per polarized-panel antenna in the 5 GHz band:

20 MHZ CHANNEL	40 MHZ CHANNEL	80 MHZ CHANNELS	LEGACY OFDM RATES (1TX)	802.11n HT20 RATES (3TX)	802.11n HT40 RATES (3TX)	802.11n HT80 RATES (3TX)
36			19.0	19.0		
38	(36, 40)		20.0	20.0	16.0	
40			20.0	20.0		
42		(36, 40, 44, 48)	20.0	20.0		11.0
44			20.0	20.0		
46	(44, 48)		20.0	20.0	20.0	
48			20.0	20.0		
52			20.0	14.0		
54	(52, 56)		20.0	14.0	16.0	
56			20.0	14.0		
58		(52, 56, 60, 64)	20.0	14.0		10.0
60			20.0	14.0		
62	(60, 64)		20.0	14.0	16.0	
64			20.0	14.0		
100			20.0	14.0		
102	(100, 104)		20.0	14.0	15.0	
104			20.0	14.0		
106		(100, 104, 108, 112)	20.0	14.0		15.0
108			20.0	14.0		
110			20.0	14.0	16.0	
112			20.0	14.0		
114			20.0	14.0		
116			20.0	14.0		
118	(116, 120)		20.0	14.0	16.0	

20 MHZ CHANNEL	40 MHZ CHANNEL	80 MHZ CHANNELS	LEGACY OFDM RATES (1TX)	802.11n HT20 RATES (3TX)	802.11n HT40 RATES (3TX)	802.11n HT80 RATES (3TX)
120			20.0	14.0		
122		(116, 120, 124, 128)	20.0	14.0		18.0
124			20.0	14.0		
126	(124, 128)		20.0	14.0	16.0	
128			20.0	14.0		
130			20.0	14.0		
132			20.0	14.0		
134	(132, 136)		20.0	14.0	16.0	
136			20.0	14.0		
138			20.0	14.0		
140			20.0	16.0		
142			20.0	16.0	18.0	
144			20.0	16.0		
149			17.0	17.0		
151	(149, 153)		20.0	20.0	15.0	
153			20.0	20.0		
155		(149, 153, 157, 161)	20.0	20.0		15.0
157			20.0	20.0		
159	(157, 161)		20.0	20.0	17.0	
161			20.0	20.0		
165			18.0	18.0		

Polarized-panel antenna, peak gain = 10.7dBi

AP7532 US Domain 5 GHz Patch Antenna Model

The following is a transmit power table (US domain) per patch antenna in the 5 GHz band:

20 MHZ CHANNEL	40 MHZ CHANNEL	80 MHZ CHANNELS	LEGACY OFDM RATES (1TX)	802.11n HT20 RATES (3TX)	802.11n HT40 RATES (3TX)	802.11n HT80 RATES (3TX)
36			20.0	20.0		
38	(36, 40)		20.0	20.0	18.0	
40			20.0	20.0		
42		(36, 40, 44, 48)	20.0	20.0		17.0
44			20.0	20.0		

20 MHZ CHANNEL	40 MHZ CHANNEL	80 MHZ CHANNELS	LEGACY OFDM RATES (1TX)	802.11n HT20 RATES (3TX)	802.11n HT40 RATES (3TX)	802.11n HT80 RATES (3TX)
46	(44, 48)		20.0	20.0	20.0	
48			20.0	20.0		
52			20.0	17.0		
54	(52, 56)		20.0	17.0	20.0	
56			20.0	17.0		
58		(52, 56, 60, 64)	20.0	17.0		16.0
60			20.0	17.0		
62	(60, 64)		20.0	17.0	20.0	
64			20.0	17.0		
100			20.0	17.0		
102	(100, 104)		20.0	17.0	18.0	
104			20.0	17.0		
106		(100, 104, 108, 112)	20.0	17.0		16.0
108			20.0	17.0		
110			20.0	17.0	20.0	
112			20.0	17.0		
114			20.0	17.0		
116			20.0	17.0		
118	(116, 120)		20.0	17.0	20.0	
120			20.0	17.0		
122		(116, 120, 124, 128)	20.0	17.0		20.0
124			20.0	17.0		
126	(124, 128)		20.0	17.0	20.0	
128			20.0	17.0		
130			20.0	17.0		
132			20.0	17.0		
134	(132, 136)		20.0	17.0	20.0	
136			20.0	17.0		
138			20.0	17.0		
140			20.0	17.0		
142			20.0	17.0	18.0	
144			20.0	16.0		
149			19.0	17.0		

20 MHZ CHANNEL	40 MHZ CHANNEL	80 MHZ CHANNELS	LEGACY OFDM RATES (1TX)	802.11n HT20 RATES (3TX)	802.11n HT40 RATES (3TX)	802.11n HT80 RATES (3TX)
151	(149, 153)		20.0	20.0	17.0	
153			20.0	20.0		
155		(149, 153, 157, 161)	20.0	20.0		16.0
157			20.0	20.0		
159	(157, 161)		20.0	20.0	18.0	
161			20.0	20.0		
165			20.0	19.0		

Patch antenna, peak gain = 5.4dBi

AP7532 EU Regulatory Domain 2.4 GHz Band

AP7532 EU Domain 2.4 GHz External Dipole Antenna Model

The following is a transmit power table (EU domain) per external dipole antenna in the 2.4 GHz band:

20 MHZ CHANNEL	40 MHZ CHANNEL	LEGACY DSSS RATES (1TX)	LEGACY OFDM RATES (1TX)	802.11n HT20 RATES/TURBO QAM (3TX)	802.11n HT40 RATES/TURBO QAM (3TX)
1		16.0	16.0	11.0	
2		16.0	16.0	11.0	
3	(1, 5)	16.0	16.0	11.0	11.0
4	(2, 6)	16.0	16.0	11.0	11.0
5	(3, 7)	16.0	16.0	11.0	11.0
6	(4, 8)	16.0	16.0	11.0	11.0
7	(5, 9)	16.0	16.0	11.0	11.0
8	(6, 10)	16.0	16.0	11.0	11.0
9	(7, 11)	16.0	16.0	11.0	11.0
10	(8, 12)	16.0	16.0	11.0	11.0
11	(9, 13)	16.0	16.0	11.0	11.0
12		16.0	16.0	11.0	
13		16.0	16.0	11.0	
14					

External dipole antenna, peak gain = 5.3dBi

AP7532 EU Domain 2.4 GHz External Panel and Polarized-Panel Antenna Models

The following is a transmit power table (EU domain) per external panel and polarized-panel antennas in the 2.4 GHz band:



Note

The use of a panel antenna requires 1ft cable between the AP and the antenna element. If the antenna gain is 5.1dB or less, the cable is not required.

20 MHZ CHANNEL	40 MHZ CHANNEL	LEGACY DSSS RATES (1TX)	LEGACY OFDM RATES (1TX)	802.11n HT20 RATES/TURBO QAM (3TX)	802.11n HT40 RATES/TURBO QAM (3TX)
1		15.0	15.0	10.0	
2		15.0	15.0	10.0	
3	(1, 5)	15.0	15.0	10.0	10.0
4	(2, 6)	15.0	15.0	10.0	10.0
5	(3, 7)	15.0	15.0	10.0	10.0
6	(4, 8)	15.0	15.0	10.0	10.0
7	(5, 9)	15.0	15.0	10.0	10.0
8	(6, 10)	15.0	15.0	10.0	10.0
9	(7, 11)	15.0	15.0	10.0	10.0
10	(8, 12)	15.0	15.0	10.0	10.0
11	(9, 13)	15.0	15.0	10.0	10.0
12		15.0	15.0	10.0	
13		15.0	15.0	10.0	
14					

External panel antenna, peak gain = 6dBi

AP7532 EU Domain 2.4 GHz Internal Antenna Model

The following is a transmit power table (EU domain) per internal antenna in the 2.4 GHz band:

20 MHZ CHANNEL	40 MHZ CHANNEL	LEGACY DSSS RATES (1TX)	LEGACY OFDM RATES (1TX)	802.11n HT20 RATES/TURBO QAM (3TX)	802.11n HT40 RATES/TURBO QAM (3TX)
1		17.0	17.0	12.0	
2		17.0	17.0	12.0	
3	(1, 5)	17.0	17.0	12.0	12.0
4	(2, 6)	17.0	17.0	12.0	12.0
5	(3, 7)	17.0	17.0	12.0	12.0
6	(4, 8)	17.0	17.0	12.0	12.0

20 MHZ CHANNEL	40 MHZ CHANNEL	LEGACY DSSS RATES (1TX)	LEGACY OFDM RATES (1TX)	802.11n HT20 RATES/TURBO QAM (3TX)	802.11n HT40 RATES/TURBO QAM (3TX)
7	(5, 9)	17.0	17.0	12.0	12.0
8	(6, 10)	17.0	17.0	12.0	12.0
9	(7, 11)	17.0	17.0	12.0	12.0
10		17.0	17.0	12.0	12.0
11		17.0	17.0	12.0	12.0
12		17.0	17.0	12.0	12.0
13		17.0	17.0	12.0	12.0
14					

Internal antenna, peak gain = 4.13dBi

AP7532 EU Domain 2.4 GHz Patch Antenna Model

The following is a transmit power table (EU domain) per patch antenna in the 2.4 GHz band:

20 MHZ CHANNEL	40 MHZ CHANNEL	LEGACY DSSS RATES (1TX)	LEGACY OFDM RATES (1TX)	802.11n HT20 RATES/TURBO QAM (3TX)	802.11n HT40 RATES/TURBO QAM (3TX)
1		16.0	16.0	11.0	
2		16.0	16.0	11.0	
3	(1, 5)	16.0	16.0	11.0	11.0
4	(2, 6)	16.0	16.0	11.0	11.0
5	(3, 7)	16.0	16.0	11.0	11.0
6	(4, 8)	16.0	16.0	11.0	11.0
7	(5, 9)	16.0	16.0	11.0	11.0
8	(6, 10)	16.0	16.0	11.0	11.0
9	(7, 11)	16.0	16.0	11.0	11.0
10		16.0	16.0	11.0	11.0
11		16.0	16.0	11.0	11.0
12		16.0	16.0	11.0	11.0
13		16.0	16.0	11.0	11.0
14					

Internal antenna, peak gain = 5dBi

AP7532 EU Regulatory Domain 5 GHz Band

AP7532 EU Domain 5 GHz External Dipole Antenna Model

The following is a transmit power table (EU domain) per external dipole antenna in the 5 GHz band:

20 MHZ CHANNEL	40 MHZ CHANNEL	80 MHZ CHANNELS	LEGACY OFDM RATES (1TX)	802.11n HT20 RATES (3TX)	802.11n HT40 RATES (3TX)	802.11n HT80 RATES (3TX)
36			19.0	14.0		
38	(36, 40)		19.0	14.0	14.0	
40			19.0	14.0		
42		(36, 40, 44, 48)	19.0	14.0		14.0
44			19.0	14.0		
46	(44, 48)		19.0	14.0	14.0	
48			19.0	14.0		
52			19.0	14.0		
54	(52, 56)		19.0	14.0	14.0	
56			19.0	14.0		
58		(52, 56, 60, 64)	19.0	14.0		14.0
60			19.0	14.0		
62	(60, 64)		19.0	14.0	14.0	
64			19.0	14.0		
100			20.0	20.0		
102	(100, 104)		20.0	20.0	20.0	
104			20.0	20.0		
106		(100, 104, 108, 112)	20.0	20.0		20.0
108			20.0	20.0		
110			20.0	20.0	20.0	
112			20.0	20.0		
114			20.0	20.0		
116			20.0	20.0		
118	(116, 120)		20.0	20.0	20.0	
120			20.0	20.0		
122		(116, 120, 124, 128)	20.0	20.0		20.0
124			20.0	20.0		
126	(124, 128)		20.0	20.0		
128			20.0	20.0		
130			20.0	20.0		

20 MHZ CHANNEL	40 MHZ CHANNEL	80 MHZ CHANNELS	LEGACY OFDM RATES (1TX)	802.11n HT20 RATES (3TX)	802.11n HT40 RATES (3TX)	802.11n HT80 RATES (3TX)
132			20.0	20.0		
134	(132, 136)		20.0	20.0	20.0	
136			20.0	20.0		
138			20.0	20.0		
140			20.0	20.0		
142			20.0	20.0	20.0	
144			20.0	20.0		
149						
151	(149, 153)					
153						
155		(149, 153, 157, 161)				
157						
159	(157, 161)					
161						
165						

External dipole antenna, peak gain = 7.3dBi

AP7532 EU Domain 5 GHz External Panel and Polarized-Panel Antenna Models

The following is a transmit power table (EU domain) per external panel and polarized-panel antennas in the 5 GHz band:

20 MHZ CHANNEL	40 MHZ CHANNEL	80 MHZ CHANNELS	LEGACY OFDM RATES (1TX)	802.11n HT20 RATES (3TX)	802.11n HT40 RATES (3TX)	802.11n HT80 RATES (3TX)
36			20.0	15.0		
38	(36, 40)		20.0	15.0	15.0	
40			20.0	15.0		
42		(36, 40, 44, 48)	20.0	15.0		15.0
44			20.0	15.0		
46	(44, 48)		20.0	15.0	15.0	
48			20.0	15.0		
52			20.0	15.0		
54	(52, 56)		20.0	15.0	15.0	
56			20.0	15.0		

20 MHZ CHANNEL	40 MHZ CHANNEL	80 MHZ CHANNELS	LEGACY OFDM RATES (1TX)	802.11n HT20 RATES (3TX)	802.11n HT40 RATES (3TX)	802.11n HT80 RATES (3TX)
58		(52, 56, 60, 64)	20.0	15.0		15.0
60			20.0	15.0		
62	(60, 64)		20.0	15.0	15.0	
64			20.0	15.0		
100			20.0	20.0		
102	(100, 104)		20.0	20.0	20.0	
104			20.0	20.0		
106		(100, 104, 108, 112)	20.0	20.0		20.0
108			20.0	20.0		
110			20.0	20.0	20.0	
112			20.0	20.0		
114			20.0	20.0		
116			20.0	20.0		
118	(116, 120)		20.0	20.0	20.0	
120			20.0	20.0		
122		(116, 120, 124, 128)	20.0	20.0		20.0
124			20.0	20.0		
126	(124, 128)		20.0	20.0	20.0	
128			20.0	20.0		
130			20.0	20.0		
132			20.0	20.0		
134	(132, 136)		20.0	20.0	20.0	
136			20.0	20.0		
138			20.0	20.0		
140			20.0	20.0		
142			20.0	20.0	20.0	
144			20.0	20.0		
149						
151	(149, 153)					
153						
155		(149, 153, 157, 161)				
157						

20 MHZ CHANNEL	40 MHZ CHANNEL	80 MHZ CHANNELS	LEGACY OFDM RATES (1TX)	802.11n HT20 RATES (3TX)	802.11n HT40 RATES (3TX)	802.11n HT80 RATES (3TX)
159	(157, 161)					
161						
165						

**Note**

The use of a panel antenna requires 1ft cable between the AP and the antenna element. If the antenna gain is 5.1dB or less, the cable is not required.

External panel antenna, peak gain = 6dBi

AP7532 EU Domain 5 GHz Internal Antenna Model

The following is a transmit power table (EU domain) per internal antenna in the 5 GHz band:

20 MHZ CHANNEL	40 MHZ CHANNEL	80 MHZ CHANNELS	LEGACY OFDM RATES (1TX)	802.11n HT20 RATES (3TX)	802.11n HT40 RATES (3TX)	802.11n HT80 RATES (3TX)
36			20.0	16.0		
38	(36, 40)		20.0	16.0	16.0	
40			20.0	16.0		
42		(36, 40, 44, 48)	20.0	16.0		16.0
44			20.0	16.0		
46	(44, 48)		20.0	16.0	16.0	
48			20.0	16.0		
52			20.0	16.0		
54	(52, 56)		20.0	16.0	16.0	
56			20.0	16.0		
58		(52, 56, 60, 64)	20.0	16.0		16.0
60			20.0	16.0		
62	(60, 64)		20.0	16.0	16.0	
64			20.0	16.0		
100			20.0	20.0		
102	(100, 104)		20.0	20.0	20.0	
104			20.0	20.0		
106		(100, 104, 108, 112)	20.0	20.0		20.0
108			20.0	20.0		

20 MHZ CHANNEL	40 MHZ CHANNEL	80 MHZ CHANNELS	LEGACY OFDM RATES (1TX)	802.11n HT20 RATES (3TX)	802.11n HT40 RATES (3TX)	802.11n HT80 RATES (3TX)
110			20.0	20.0	20.0	
112			20.0	20.0		
114			20.0	20.0		
116			20.0	20.0		
118	(116, 120)		20.0	20.0	20.0	
120			20.0	20.0		
122		(116, 120, 124, 128)	20.0	20.0		20.0
124			20.0	20.0		
126	(124, 128)		20.0	20.0	20.0	
128			20.0	20.0		
130			20.0	20.0		
132			20.0	20.0		
134	(132, 136)		20.0	20.0	20.0	
136			20.0	20.0		
138			20.0	20.0		
140			20.0	20.0		
142			20.0	20.0	20.0	
144			20.0	20.0		
149						
151	(149, 153)					
153						
155		(149, 153, 157, 161)				
157						
159	(157, 161)					
161						
165						

Internal antenna, peak gain = 5.92dBi

AP7532 EU Domain 5 GHz Patch Antenna Model

The following is a transmit power table (EU domain) per patch antenna in the 5 GHz band:

20 MHZ CHANNEL	40 MHZ CHANNEL	80 MHZ CHANNELS	LEGACY OFDM RATES (1TX)	802.11n HT20 RATES (3TX)	802.11n HT40 RATES (3TX)	802.11n HT80 RATES (3TX)
36			20.0	16.0		
38	(36, 40)		20.0	16.0	16.0	
40			20.0	16.0		
42		(36, 40, 44, 48)	20.0	16.0		16.0
44			20.0	16.0		
46	(44, 48)		20.0	16.0	16.0	
48			20.0	16.0		
52			20.0	16.0		
54	(52, 56)		20.0	16.0	16.0	
56			20.0	16.0		
58		(52, 56, 60, 64)	20.0	16.0		16.0
60			20.0	16.0		
62	(60, 64)		20.0	16.0	16.0	
64			20.0	16.0		
100			20.0	20.0		
102	(100, 104)		20.0	20.0	20.0	
104			20.0	20.0		
106		(100, 104, 108, 112)	20.0	20.0		20.0
108			20.0	20.0		
110			20.0	20.0	20.0	
112			20.0	20.0		
114			20.0	20.0		
116			20.0	20.0		
118	(116, 120)		20.0	20.0	20.0	
120			20.0	20.0		
122		(116, 120, 124, 128)	20.0	20.0		20.0
124			20.0	20.0		
126	(124, 128)		20.0	20.0	20.0	
128			20.0	20.0		
130			20.0	20.0		
132			20.0	20.0		
134	(132, 136)		20.0	20.0	20.0	

20 MHZ CHANNEL	40 MHZ CHANNEL	80 MHZ CHANNELS	LEGACY OFDM RATES (1TX)	802.11n HT20 RATES (3TX)	802.11n HT40 RATES (3TX)	802.11n HT80 RATES (3TX)
136			20.0	20.0		
138			20.0	20.0		
140			20.0	20.0		
142			20.0	20.0	20.0	
144			20.0	20.0		
149						
151	(149, 153)					
153						
155		(149, 153, 157, 161)				
157						
159	(157, 161)					
161						
165						

Internal antenna, peak gain = 5.4dBi

AP7532 Japan Regulatory Domain 2.4 GHz Band

AP7532 Japan Domain 2.4 GHz External Dipole Antenna Model

The following is a transmit power table (Japan domain) per external dipole antenna in the 2.4 GHz band:

20 MHZ CHANNEL	40 MHZ CHANNEL	LEGACY DSSS RATES (1TX)	LEGACY OFDM RATES (1TX)	802.11n HT20 RATES/TURBO QAM (3TX)	802.11n HT40 RATES/TURBO QAM (3TX)
1		20.0	20.0	18.0	
2		20.0	20.0	18.0	
3	(1, 5)	20.0	20.0	18.0	18.0
4	(2, 6)	20.0	20.0	18.0	18.0
5	(3, 7)	20.0	20.0	18.0	18.0
6	(4, 8)	20.0	20.0	18.0	18.0
7	(5, 9)	20.0	20.0	18.0	18.0
8	(6, 10)	20.0	20.0	18.0	18.0
9	(7, 11)	20.0	20.0	18.0	18.0
10	(8, 12)	20.0	20.0	18.0	18.0

20 MHZ CHANNEL	40 MHZ CHANNEL	LEGACY DSSS RATES (1TX)	LEGACY OFDM RATES (1TX)	802.11n HT20 RATES/TURBO QAM (3TX)	802.11n HT40 RATES/TURBO QAM (3TX)
11	(9, 13)	20.0	20.0	18.0	18.0
12		20.0	20.0	18.0	
13		20.0	20.0	18.0	

External dipole antenna, peak gain = 3.17dBi

AP7532 Japan Domain 2.4 GHz External Panel Antenna Model

The following is a transmit power table (Japan domain) per external panel antenna in the 2.4 GHz band:



Note

The use of this panel antenna requires 1ft cable between the AP and the antenna element. If the antenna gain is 5.1dB or less, the cable is not required.

20 MHZ CHANNEL	40 MHZ CHANNEL	LEGACY DSSS RATES (1TX)	LEGACY OFDM RATES (1TX)	802.11n HT20 RATES/TURBO QAM (3TX)	802.11n HT40 RATES/TURBO QAM (3TX)
1		16.0	16.0	11.0	
2		16.0	16.0	11.0	
3	(1, 5)	16.0	16.0	11.0	11.0
4	(2, 6)	16.0	16.0	11.0	11.0
5	(3, 7)	16.0	16.0	11.0	11.0
6	(4, 8)	16.0	16.0	11.0	11.0
7	(5, 9)	16.0	16.0	11.0	11.0
8	(6, 10)	16.0	16.0	11.0	11.0
9	(7, 11)	16.0	16.0	11.0	11.0
10	(8, 12)	16.0	16.0	11.0	11.0
11	(9, 13)	16.0	16.0	11.0	11.0
12		16.0	16.0	11.0	
13		16.0	16.0	11.0	

External panel antenna, peak gain = 5.5dBi

AP7532 Japan Domain 2.4 GHz Internal Antenna Model

The following is a transmit power table (Japan domain) per internal antenna in the 2.4 GHz band:

20 MHZ CHANNEL	40 MHZ CHANNEL	LEGACY DSSS RATES (1TX)	LEGACY OFDM RATES (1TX)	802.11n HT20 RATES/TURBO QAM (3TX)	802.11n HT40 RATES/TURBO QAM (3TX)
1		18.0	20.0	16.0	
2		18.0	20.0	16.0	
3	(1, 5)	18.0	20.0	16.0	16.0
4	(2, 6)	18.0	20.0	16.0	16.0
5	(3, 7)	18.0	20.0	16.0	16.0
6	(4, 8)	18.0	20.0	16.0	16.0
7	(5, 9)	18.0	20.0	16.0	16.0
8	(6, 10)	18.0	20.0	16.0	16.0
9	(7, 11)	18.0	20.0	16.0	16.0
10		18.0	20.0	16.0	16.0
11		18.0	20.0	16.0	16.0
12		18.0	20.0	16.0	
13		18.0	20.0	16.0	

Internal antenna, peak gain = 4.13dBi

AP7532 Japan Regulatory Domain 5 GHz Band

AP7532 Japan Domain 5 GHz External Dipole Antenna Model

The following is a transmit power table (Japan domain) per external dipole antenna in the 5 GHz band:

20 MHZ CHANNEL	40 MHZ CHANNEL	80 MHZ CHANNELS	LEGACY OFDM RATES (1TX)	802.11n HT20 RATES (3TX)	802.11n HT40 RATES (3TX)	802.11n HT80 RATES (3TX)
36			20.0	16.0		
38	(36, 40)		20.0	16.0	16.0	
40			20.0	16.0		
42		(36, 40, 44, 48)	20.0	16.0		16.0
44			20.0	16.0		
46	(44, 48)		20.0	16.0	16.0	
48			20.0	16.0		
52			20.0	16.0		
54	(52, 56)		20.0	16.0	16.0	
56			20.0	16.0		
58		(52, 56, 60, 64)	20.0	16.0		16.0

20 MHZ CHANNEL	40 MHZ CHANNEL	80 MHZ CHANNELS	LEGACY OFDM RATES (1TX)	802.11n HT20 RATES (3TX)	802.11n HT40 RATES (3TX)	802.11n HT80 RATES (3TX)
60			20.0	16.0		
62	(60, 64)		20.0	16.0	16.0	
64			20.0	16.0		
100			20.0	20.0		
102	(100, 104)		20.0	20.0	20.0	
104			20.0	20.0		
106		(100, 104, 108, 112)	20.0	20.0		20.0
108			20.0	20.0		
110			20.0	20.0	20.0	
112			20.0	20.0		
114			20.0	20.0		
116			20.0	20.0		
118	(116, 120)		20.0	20.0	20.0	
120			20.0	20.0		
122		(116, 120, 124, 128)	20.0	20.0		20.0
124			20.0	20.0		
126	(124, 128)		20.0	20.0		
128			20.0	20.0		
130			20.0	20.0		
132			20.0	20.0		
134	(132, 136)		20.0	20.0	20.0	
136			20.0	20.0		
138			20.0	20.0		
140			20.0	20.0		
142			20.0	20.0	20.0	
144			20.0	20.0		

External dipole antenna, peak gain = 5dBi

AP7532 Japan Domain 5 GHz External Panel Antenna Model

The following is a transmit power table (Japan domain) per external panel antenna in the 5 GHz band:



Note

The use of this panel antenna requires 1ft cable between the AP and the antenna element. If the antenna gain is 5.1dB or less, the cable is not required.

20 MHZ CHANNEL	40 MHZ CHANNEL	80 MHZ CHANNELS	LEGACY OFDM RATES (1TX)	802.11n HT20 RATES (3TX)	802.11n HT40 RATES (3TX)	802.11n HT80 RATES (3TX)
36			20.0	15.0		
38	(36, 40)		20.0	15.0	15.0	
40			20.0	15.0		
42		(36, 40, 44, 48)	20.0	15.0		15.0
44			20.0	15.0		
46	(44, 48)		20.0	15.0	15.0	
48			20.0	15.0		
52			20.0	15.0		
54	(52, 56)		20.0	15.0	15.0	
56			20.0	15.0		
58		(52, 56, 60, 64)	20.0	15.0		15.0
60			20.0	15.0		
62	(60, 64)		20.0	15.0	15.0	
64			20.0	15.0		
100			20.0	20.0		
102	(100, 104)		20.0	20.0	20.0	
104			20.0	20.0		
106		(100, 104, 108, 112)	20.0	20.0		20.0
108			20.0	20.0		
110			20.0	20.0	20.0	
112			20.0	20.0		
114			20.0	20.0		
116			20.0	20.0		
118	(116, 120)		20.0	20.0	20.0	
120			20.0	20.0		
122		(116, 120, 124, 128)	20.0	20.0		20.0
124			20.0	20.0		
126	(124, 128)		20.0	20.0	20.0	
128			20.0	20.0		
130			20.0	20.0		
132			20.0	20.0		
134	(132, 136)		20.0	20.0	20.0	

20 MHZ CHANNEL	40 MHZ CHANNEL	80 MHZ CHANNELS	LEGACY OFDM RATES (1TX)	802.11n HT20 RATES (3TX)	802.11n HT40 RATES (3TX)	802.11n HT80 RATES (3TX)
136			20.0	20.0		
138			20.0	20.0		
140			20.0	20.0		
142			20.0	20.0	20.0	
144			20.0	20.0		

External panel antenna, peak gain = 6dBi

AP7532 Japan Domain 5 GHz Internal Antenna Model

The following is a transmit power table (Japan domain) per internal antenna in the 5 GHz band:

20 MHZ CHANNEL	40 MHZ CHANNEL	80 MHZ CHANNELS	LEGACY OFDM RATES (1TX)	802.11n HT20 RATES (3TX)	802.11n HT40 RATES (3TX)	802.11n HT80 RATES (3TX)
36			17.0	12.0		
38	(36, 40)		17.0	12.0	12.0	
40			17.0	12.0		
42		(36, 40, 44, 48)	17.0	12.0		12.0
44			17.0	12.0		
46	(44, 48)		17.0	12.0	12.0	
48			17.0	12.0		
52			17.0	12.0		
54	(52, 56)		17.0	12.0	12.0	
56			17.0	12.0		
58		(52, 56, 60, 64)	17.0	12.0		12.0
60			17.0	12.0		
62	(60, 64)		17.0	12.0	12.0	
64			17.0	12.0		
100			20.0	19.0		
102	(100, 104)		20.0	19.0	19.0	
104			20.0	19.0		
106		(100, 104, 108, 112)	20.0	19.0		19.0
108			20.0	19.0		
110			20.0	19.0	19.0	
112			20.0	19.0		

20 MHZ CHANNEL	40 MHZ CHANNEL	80 MHZ CHANNELS	LEGACY OFDM RATES (1TX)	802.11n HT20 RATES (3TX)	802.11n HT40 RATES (3TX)	802.11n HT80 RATES (3TX)
114			20.0	19.0		
116			20.0	19.0		
118	(116, 120)		20.0	19.0	19.0	
120			20.0	19.0		
122		(116, 120, 124, 128)	20.0	19.0		19.0
124			20.0	19.0		
126	(124, 128)		20.0	19.0	19.0	
128			20.0	19.0		
130			20.0	19.0		
132			20.0	19.0		
134	(132, 136)		20.0	19.0	19.0	
136			20.0	19.0		
138			20.0	19.0		
140			20.0	19.0		
142			20.0	19.0	19.0	
144			20.0	19.0		

Internal antenna, peak gain = 5.92dBi

AP7532 NCC Domain

Refer to the following for an AP7532 antenna power table for the NCC domain.

2.4 GHz 2412 to 2462 MHz

	Antenna Gain (dBi)	Type	Max Conducted Power Settings (dBm)
ML-2452-APA2-01	3.7	Dipole	21
ML-2452-HPA5-036	3	Dipole	21
ML-2452-PNA5-01R	4.8	Panel	21

5.2 GHz 5250 to 5350 MHz

	Antenna Gain (dBi)	Type	Max Conducted Power Settings (dBm)
ML-2452-APA2-01	4.85	Dipole	15
ML-2452-HPA5-036	5	Dipole	15
ML-2452-PNA5-01R	5.1	Panel	15

5470 to 5725 MHz

	Antenna Gain (dBi)	Type	Max Conducted Power Settings (dBm)
ML-2452-APA2-01	4.85	Dipole	20
ML-2452-HPA5-036	5	Dipole	20
ML-2452-PNA5-01R	5.1	Panel	20

5725 to 5850 MHz

	Antenna Gain (dBi)	Type	Max Conducted Power Settings (dBm)
ML-2452-APA2-01	4.85	Dipole	20
ML-2452-HPA5-036	5	Dipole	20
ML-2452-PNA5-01R	5.1	Panel	20

23 AP7522 Regulatory Domains

AP7522 US Regulatory Domain 2.4 GHz Band
 AP7522 US Regulatory Domain 5 GHz Band
 AP7522 EU Regulatory Domain 2.4 GHz Band
 AP7522 EU Regulatory Domain 5 GHz Band
 AP7522 Japan Regulatory Domain 2.4 GHz Band
 AP7522 Japan Regulatory Domain 5 GHz Band
 AP7522 NCC Domain

AP7522 US Regulatory Domain 2.4 GHz Band

AP7522 US Domain 2.4 GHz External Dipole Antenna Maximum Conducted Transmit Power Settings

The following is a transmit power table (US domain) per external dipole antenna in the 2.4 GHz band:

20 MHZ CHANNEL	40 MHZ CHANNEL	LEGACY DSSS RATES (1TX)	LEGACY OFDM RATES (1TX)	802.11n HT20 RATES/TURBO QAM (2TX)	802.11n HT40 RATES/TURBO QAM (2TX)
1		19.0	15.0	14.0	
2		20.0	20.0	20.0	
3	(1, 5)	20.0	20.0	20.0	11.0
4	(2, 6)	20.0	20.0	20.0	14.0
5	(3, 7)	20.0	20.0	20.0	14.0
6	(4, 8)	20.0	20.0	20.0	14.0
7	(5, 9)	20.0	20.0	20.0	14.0
8	(6, 10)	20.0	20.0	20.0	14.0
9	(7, 11)	20.0	20.0	20.0	13.0
10		20.0	20.0	20.0	
11		19.0	15.0	15.0	

External dipole antenna, peak gain = 5.3dBi

AP7522 US Domain 2.4 GHz External Panel Antenna Maximum Conducted Transmit Power Settings

The following is a transmit power table (US domain) per external panel antenna in the 2.4 GHz band:



Note

The use of this panel antenna requires 1ft cable between the AP and the antenna element. If the antenna gain is 4.8 dB or less, the cable is not required.

20 MHZ CHANNEL	40 MHZ CHANNEL	LEGACY DSSS RATES (1TX)	LEGACY OFDM RATES (1TX)	802.11n HT20 RATES/TURBO QAM (2TX)	802.11n HT40 RATES/TURBO QAM (2TX)
1		20.0	15.0	15.0	
2		20.0	20.0	20.0	
3	(1, 5)	20.0	20.0	20.0	13.0
4	(2, 6)	20.0	20.0	20.0	14.0
5	(3, 7)	20.0	20.0	20.0	14.0
6	(4, 8)	20.0	20.0	20.0	14.0
7	(5, 9)	20.0	20.0	20.0	14.0
8	(6, 10)	20.0	20.0	20.0	14.0
9	(7, 11)	20.0	20.0	20.0	13.0
10		20.0	20.0	20.0	
11		20.0	16.0	16.0	

External panel antenna, peak gain = 5.5dBi

AP7522 US Domain 2.4 GHz Internal Antenna Maximum Conducted Transmit Power Settings

The following is a transmit power table (US domain) per internal antenna in the 2.4 GHz band:

20 MHZ CHANNEL	40 MHZ CHANNEL	LEGACY DSSS RATES (1TX)	LEGACY OFDM RATES (1TX)	802.11n HT20 RATES/TURBO QAM (2TX)	802.11n HT40 RATES/TURBO QAM (2TX)
1		20.0	15.0	15.0	
2		20.0	20.0	20.0	
3	(1, 5)	20.0	20.0	20.0	14.0
4	(2, 6)	20.0	20.0	20.0	15.0
5	(3, 7)	20.0	20.0	20.0	15.0
6	(4, 8)	20.0	20.0	20.0	15.0
7	(5, 9)	20.0	20.0	20.0	15.0
8	(6, 10)	20.0	20.0	20.0	15.0
9	(7, 11)	20.0	20.0	20.0	15.0

20 MHZ CHANNEL	40 MHZ CHANNEL	LEGACY DSSS RATES (1TX)	LEGACY OFDM RATES (1TX)	802.11n HT20 RATES/TURBO QAM (2TX)	802.11n HT40 RATES/TURBO QAM (2TX)
10		20.0	20.0	20.0	
11		20.0	17.0	15.0	

Internal antenna, peak gain = 4.13dBi

AP7522 US Domain 2.4 GHz Polarized-Panel Antenna Maximum Conducted Transmit Power Settings

The following is a transmit power table (US domain) per polarized-panel antenna in the 2.4 GHz band:

20 MHZ CHANNEL	40 MHZ CHANNEL	LEGACY DSSS RATES (1TX)	LEGACY OFDM RATES (1TX)	802.11n HT20 RATES/TURBO QAM (2TX)	802.11n HT40 RATES/TURBO QAM (2TX)
1		20.0	16.0	16.0	
2		20.0	20.0	20.0	
3	(1, 5)	20.0	20.0	20.0	14.0
4	(2, 6)	20.0	20.0	20.0	15.0
5	(3, 7)	20.0	20.0	20.0	15.0
6	(4, 8)	20.0	20.0	20.0	15.0
7	(5, 9)	20.0	20.0	20.0	15.0
8	(6, 10)	20.0	20.0	20.0	15.0
9	(7, 11)	20.0	20.0	20.0	13.0
10		20.0	20.0	20.0	
11		20.0	17.0	13.0	

Polarized-panel antenna, peak gain = 11dBi

AP7522 US Domain 2.4 GHz Patch Antenna Maximum Conducted Transmit Power Settings

The following is a transmit power table (US domain) per patch antenna in the 2.4 GHz band:

20 MHZ CHANNEL	40 MHZ CHANNEL	LEGACY DSSS RATES (1TX)	LEGACY OFDM RATES (1TX)	802.11n HT20 RATES/TURBO QAM (2TX)	802.11n HT40 RATES/TURBO QAM (2TX)
1		20.0	17.0	15.0	
2		20.0	20.0	20.0	
3	(1, 5)	20.0	20.0	20.0	13.0
4	(2, 6)	20.0	20.0	20.0	15.0

20 MHZ CHANNEL	40 MHZ CHANNEL	LEGACY DSSS RATES (1TX)	LEGACY OFDM RATES (1TX)	802.11n HT20 RATES/TURBO QAM (2TX)	802.11n HT40 RATES/TURBO QAM (2TX)
5	(3, 7)	20.0	20.0	20.0	15.0
6	(4, 8)	20.0	20.0	20.0	15.0
7	(5, 9)	20.0	20.0	20.0	15.0
8	(6, 10)	20.0	20.0	20.0	15.0
9	(7, 11)	20.0	20.0	20.0	14.0
10		20.0	20.0	20.0	
11		20.0	17.0	15.0	

Internal antenna, peak gain = 5.5dBi

AP7522 US Regulatory Domain 5 GHz Band

AP7522 US Domain 5 GHz External Dipole Antenna Model

The following is a transmit power table (US domain) per external dipole antenna in the 5 GHz band:

20 MHZ CHANNEL	40 MHZ CHANNEL	80 MHZ CHANNELS	LEGACY OFDM RATES (1TX)	802.11n HT20 RATES (2TX)	802.11n HT40 RATES (2TX)	802.11n HT80 RATES (2TX)
36			20.0	19.0		
38	(36, 40)		20.0	19.0	17.0	
40			20.0	19.0		
42		(36, 40, 44, 48)	20.0	19.0		17.0
44			20.0	19.0		
46	(44, 48)		20.0	19.0	20.0	
48			20.0	19.0		
52			19.0	19.0		
54	(52, 56)		19.0	19.0	20.0	
56			19.0	19.0		
58		(52, 56, 60, 64)	19.0	19.0		14.0
60			19.0	19.0		
62	(60, 64)		19.0	19.0	20.0	
64			19.0	19.0		
100			18.0	18.0		
102	(100, 104)		20.0	20.0	15.0	
104			20.0	20.0		

20 MHZ CHANNEL	40 MHZ CHANNEL	80 MHZ CHANNELS	LEGACY OFDM RATES (1TX)	802.11n HT20 RATES (2TX)	802.11n HT40 RATES (2TX)	802.11n HT80 RATES (2TX)
106		(100, 104, 108, 112)	20.0	20.0		15.0
108			20.0	20.0		
110			20.0	20.0	20.0	
112			20.0	20.0		
114			20.0	20.0		
116			20.0	20.0		
118	(116, 120)		20.0	20.0	20.0	
120			20.0	20.0		
122		(116, 120, 124, 128)	20.0	20.0		20.0
124			20.0	20.0		
126	(124, 128)		20.0	20.0	20.0	
128			20.0	20.0		
130			20.0	20.0		
132			20.0	20.0		
134	(132, 136)		20.0	20.0	18.0	
136			20.0	20.0		
138			20.0	20.0		
140			16.0	16.0		
142			16.0	16.0	20.0	
144			20.0	20.0		
149			16.0	17.0		
151	(149, 153)		20.0	20.0	15.0	
153			20.0	20.0		
155		(149, 153, 157, 161)	20.0	20.0		15.0
157			20.0	20.0		
159	(157, 161)		20.0	20.0	16.0	
161			20.0	20.0		
165			17.0	17.0		

External dipole antenna, peak gain = 7.3dBi

External Panel Antenna Model

The following is a transmit power table (US domain) per external panel antenna in the 5 GHz band:



Note

The use of this panel antenna requires 1ft cable between the AP and the antenna element. If the antenna gain is 4.8 dB or less, the cable is not required.

20 MHZ CHANNEL	40 MHZ CHANNEL	80 MHZ CHANNELS	LEGACY OFDM RATES (ITX)	802.11n HT20 RATES (2TX)	802.11n HT40 RATES (2TX)	802.11n HT80 RATES (2TX)
36			19.0	19.0		
38	(36, 40)		20.0	20.0	15.0	
40			20.0	20.0		
42		(36, 40, 44, 48)	20.0	20.0		16.0
44			20.0	20.0		
46	(44, 48)		20.0	20.0	20.0	
48			20.0	20.0		
52			19.0	20.0		
54	(52, 56)		19.0	20.0	20.0	
56			20.0	20.0		
58		(52, 56, 60, 64)	20.0	20.0		13.0
60			20.0	20.0		
62	(60, 64)		20.0	20.0	20.0	
64			19.0	19.0		
100			19.0	18.0		
102	(100, 104)		20.0	20.0	15.0	
104			20.0	20.0		
106		(100, 104, 108, 112)	20.0	20.0		16.0
108			20.0	20.0		
110			20.0	20.0	19.0	
112			20.0	20.0		
114			20.0	20.0		
116			20.0	20.0		
118	(116, 120)		20.0	20.0	19.0	
120			20.0	20.0		
122		(116, 120, 124, 128)	20.0	20.0		20.0
124			20.0	20.0		

20 MHZ CHANNEL	40 MHZ CHANNEL	80 MHZ CHANNELS	LEGACY OFDM RATES (1TX)	802.11n HT20 RATES (2TX)	802.11n HT40 RATES (2TX)	802.11n HT80 RATES (2TX)
126	(124, 128)		20.0	20.0	19.0	
128			20.0	20.0		
130			20.0	20.0		
132			20.0	20.0		
134	(132, 136)		20.0	20.0	18.0	
136			20.0	20.0		
138			20.0	20.0		
140			16.0	16.0		
142			16.0	16.0	20.0	
144			20.0	20.0		
149			18.0	16.0		
151	(149, 153)		20.0	20.0	15.0	
153			20.0	20.0		
155		(149, 153, 157, 161)	20.0	20.0		16.0
157			20.0	20.0		
159	(157, 161)		20.0	20.0	16.0	
161			20.0	20.0		
165			19.0	16.0		

External panel antenna, peak gain = 6dBi

AP7522 US Domain 5 GHz Internal Antenna Model

The following is a transmit power table (US domain) per internal antenna in the 5 GHz band:

20 MHZ CHANNEL	40 MHZ CHANNEL	80 MHZ CHANNELS	LEGACY OFDM RATES (1TX)	802.11n HT20 RATES (2TX)	802.11n HT40 RATES (2TX)	802.11n HT80 RATES (2TX)
36			19.0	18.0		
38	(36, 40)		20.0	19.0	15.0	
40			20.0	19.0		
42		(36, 40, 44, 48)	20.0	19.0		14.0
44			20.0	19.0		
46	(44, 48)		20.0	19.0	20.0	
48			20.0	19.0		
52			20.0	17.0		

20 MHZ CHANNEL	40 MHZ CHANNEL	80 MHZ CHANNELS	LEGACY OFDM RATES (1TX)	802.11n HT20 RATES (2TX)	802.11n HT40 RATES (2TX)	802.11n HT80 RATES (2TX)
54	(52, 56)		20.0	17.0	20.0	
56			20.0	17.0		
58		(52, 56, 60, 64)	20.0	17.0		13.0
60			20.0	17.0		
62	(60, 64)		20.0	17.0	20.0	
64			18.0	17.0		
100			20.0	17.0		
102	(100, 104)		20.0	17.0	13.0	
104			20.0	17.0		
106		(100, 104, 108, 112)	20.0	17.0		14.0
108			20.0	17.0		
110			20.0	17.0	18.0	
112			20.0	17.0		
114			20.0	17.0		
116			20.0	17.0		
118	(116, 120)		20.0	17.0	18.0	
120			20.0	17.0		
122		(116, 120, 124, 128)	20.0	17.0		19.0
124			20.0	17.0		
126	(124, 128)		20.0	17.0	18.0	
128			20.0	17.0		
130			20.0	17.0		
132			20.0	17.0		
134	(132, 136)		20.0	17.0	17.0	
136			20.0	17.0		
138			20.0	17.0		
140			16.0	16.0		
142			16.0	16.0	18.0	
144			20.0	18.0		
149			16.0	15.0		
151	(149, 153)		20.0	17.0	13.0	
153			20.0	17.0		

20 MHZ CHANNEL	40 MHZ CHANNEL	80 MHZ CHANNELS	LEGACY OFDM RATES (1TX)	802.11n HT20 RATES (2TX)	802.11n HT40 RATES (2TX)	802.11n HT80 RATES (2TX)
155		(149, 153, 157, 161)	20.0	17.0		10.0
157			20.0	17.0		
159	(157, 161)		20.0	17.0	15.0	
161			20.0	17.0		
165			17.0	17.0		

Internal antenna, peak gain = 5.92dBi

AP7522 US Domain 5 GHz Polarized-Panel Antenna Model

The following is a transmit power table (US domain) per polarized-panel antenna in the 5 GHz band:

20 MHZ CHANNEL	40 MHZ CHANNEL	80 MHZ CHANNELS	LEGACY OFDM RATES (1TX)	802.11n HT20 RATES (2TX)	802.11n HT40 RATES (2TX)	802.11n HT80 RATES (2TX)
36			19.0	19.0		
38	(36, 40)		20.0	20.0	18.0	
40			20.0	20.0		
42		(36, 40, 44, 48)	20.0	20.0		17.0
44			20.0	20.0		
46	(44, 48)		20.0	20.0	20.0	
48			20.0	20.0		
52			20.0	17.0		
54	(52, 56)		20.0	17.0	17.0	
56			20.0	17.0		
58		(52, 56, 60, 64)	20.0	17.0		14.0
60			20.0	17.0		
62	(60, 64)		20.0	17.0	17.0	
64			18.0	17.0		
100			18.0	17.0		
102	(100, 104)		20.0	17.0	16.0	
104			20.0	17.0		
106		(100, 104, 108, 112)	20.0	17.0		15.0
108			20.0	17.0		
110			20.0	17.0	17.0	

20 MHZ CHANNEL	40 MHZ CHANNEL	80 MHZ CHANNELS	LEGACY OFDM RATES (1TX)	802.11n HT20 RATES (2TX)	802.11n HT40 RATES (2TX)	802.11n HT80 RATES (2TX)
112			20.0	17.0		
114			20.0	17.0		
116			20.0	17.0		
118	(116, 120)		20.0	17.0	17.0	
120			20.0	17.0		
122		(116, 120, 124, 128)	20.0	17.0		20.0
124			20.0	17.0		
126	(124, 128)		20.0	17.0	17.0	
128			20.0	17.0		
130			20.0	17.0		
132			20.0	17.0		
134	(132, 136)		20.0	17.0	17.0	
136			20.0	17.0		
138			20.0	17.0		
140			16.0	17.0		
142			16.0	17.0	20.0	
144			20.0	17.0		
149			17.0	17.0		
151	(149, 153)		20.0	20.0	15.0	
153			20.0	20.0		
155		(149, 153, 157, 161)	20.0	20.0		15.0
157			20.0	20.0		
159	(157, 161)		20.0	20.0	19.0	
161			20.0	20.0		
165			18.0	17.0		

Polarized-panel antenna, peak gain = 10.7dBi

AP7522 US Domain 5 GHz Patch Antenna Model

The following is a transmit power table (US domain) per patch antenna in the 5 GHz band:

20 MHZ CHANNEL	40 MHZ CHANNEL	80 MHZ CHANNELS	LEGACY OFDM RATES (1TX)	802.11n HT20 RATES (2TX)	802.11n HT40 RATES (2TX)	802.11n HT80 RATES (2TX)
36			20.0	20.0		
38	(36, 40)		20.0	20.0	19.0	
40			20.0	20.0		
42		(36, 40, 44, 48)	20.0	20.0		18.0
44			20.0	20.0		
46	(44, 48)		20.0	20.0	20.0	
48			20.0	20.0		
52			20.0	20.0		
54	(52, 56)		20.0	20.0	20.0	
56			20.0	20.0		
58		(52, 56, 60, 64)	20.0	20.0		18.0
60			20.0	20.0		
62	(60, 64)		20.0	20.0	20.0	
64			18.0	20.0		
100			18.0	20.0		
102	(100, 104)		20.0	20.0	18.0	
104			20.0	20.0		
106		(100, 104, 108, 112)	20.0	20.0		18.0
108			20.0	20.0		
110			20.0	20.0	20.0	
112			20.0	20.0		
114			20.0	20.0		
116			20.0	20.0		
118	(116, 120)		20.0	20.0	20.0	
120			20.0	20.0		
122		(116, 120, 124, 128)	20.0	20.0		20.0
124			20.0	20.0		
126	(124, 128)		20.0	20.0	20.0	
128			20.0	20.0		
130			20.0	20.0		
132			20.0	20.0		
134	(132, 136)		20.0	20.0	18.0	

20 MHZ CHANNEL	40 MHZ CHANNEL	80 MHZ CHANNELS	LEGACY OFDM RATES (1TX)	802.11n HT20 RATES (2TX)	802.11n HT40 RATES (2TX)	802.11n HT80 RATES (2TX)
136			20.0	20.0		
138			20.0	20.0		
140			16.0	20.0		
142			16.0	20.0	20.0	
144			20.0	20.0		
149			19.0	16.0		
151	(149, 153)		20.0	20.0	17.0	
153			20.0	20.0		
155		(149, 153, 157, 161)	20.0	20.0		18.0
157			20.0	20.0		
159	(157, 161)		20.0	20.0	20.0	
161			20.0	20.0		
165			20.0	17.0		

Patch antenna, peak gain = 5.4dBi

AP7522 EU Regulatory Domain 2.4 GHz Band

AP7522 EU Domain 2.4 GHz External Dipole Antenna Maximum Conducted Transmit Power Settings

The following is a transmit power table (EU domain) per external dipole antenna in the 2.4 GHz band:

20 MHZ CHANNEL	40 MHZ CHANNEL	LEGACY DSSS RATES (1TX)	LEGACY OFDM RATES (1TX)	802.11n HT20 RATES/TURBO QAM (2TX)	802.11n HT40 RATES/TURBO QAM (2TX)
1		16.0	16.0	13.0	
2		16.0	16.0	13.0	
3	(1, 5)	16.0	16.0	13.0	13.0
4	(2, 6)	16.0	16.0	13.0	13.0
5	(3, 7)	16.0	16.0	13.0	13.0
6	(4, 8)	16.0	16.0	13.0	13.0
7	(5, 9)	16.0	16.0	13.0	13.0
8	(6, 10)	16.0	16.0	13.0	13.0
9	(7, 11)	16.0	16.0	13.0	13.0
10		16.0	16.0	13.0	13.0
11		16.0	16.0	13.0	13.0

20 MHZ CHANNEL	40 MHZ CHANNEL	LEGACY DSSS RATES (1TX)	LEGACY OFDM RATES (1TX)	802.11n HT20 RATES/TURBO QAM (2TX)	802.11n HT40 RATES/TURBO QAM (2TX)
12		16.0	16.0	13.0	13.0
13		16.0	16.0	13.0	
14					

Dipole antenna, peak gain = 5.3dBi

AP7522 EU Domain 2.4 GHz External Panel and Polarized-Panel Antenna Maximum Conducted Transmit Power Settings

The following is a transmit power table (EU domain) per external panel or polarized panel antenna in the 2.4 GHz band:



Note

The use of a panel antenna requires 1ft cable between the AP and the antenna element. If the antenna gain is 5.1 dB or less, the cable is not required.

20 MHZ CHANNEL	40 MHZ CHANNEL	LEGACY DSSS RATES (1TX)	LEGACY OFDM RATES (1TX)	802.11n HT20 RATES/TURBO QAM (2TX)	802.11n HT40 RATES/TURBO QAM (2TX)
1		15.0	15.0	12.0	
2		15.0	15.0	12.0	
3	(1, 5)	15.0	15.0	12.0	12.0
4	(2, 6)	15.0	15.0	12.0	12.0
5	(3, 7)	15.0	15.0	12.0	12.0
6	(4, 8)	15.0	15.0	12.0	12.0
7	(5, 9)	15.0	15.0	12.0	12.0
8	(6, 10)	15.0	15.0	12.0	12.0
9	(7, 11)	15.0	15.0	12.0	12.0
10		15.0	15.0	12.0	12.0
11		15.0	15.0	12.0	12.0
12		15.0	15.0	12.0	12.0
13		15.0	15.0	12.0	
14					

External panel and polarized-panel antenna, peak gain = 6dBi

AP7522 EU Domain 2.4 GHz Internal Antenna Maximum Conducted Transmit Power Settings

The following is a transmit power table (EU domain) per internal antenna in the 2.4 GHz band:

20 MHZ CHANNEL	40 MHZ CHANNEL	LEGACY DSSS RATES (1TX)	LEGACY OFDM RATES (1TX)	802.11n HT20 RATES/TURBO QAM (2TX)	802.11n HT40 RATES/TURBO QAM (2TX)
1		17.0	17.0	14.0	
2		17.0	17.0	14.0	
3	(1, 5)	17.0	17.0	14.0	14.0
4	(2, 6)	17.0	17.0	14.0	14.0
5	(3, 7)	17.0	17.0	14.0	14.0
6	(4, 8)	17.0	17.0	14.0	14.0
7	(5, 9)	17.0	17.0	14.0	14.0
8	(6, 10)	17.0	17.0	14.0	14.0
9	(7, 11)	17.0	17.0	14.0	14.0
10		17.0	17.0	14.0	14.0
11		17.0	17.0	14.0	14.0
12		17.0	17.0	14.0	14.0
13		17.0	17.0	14.0	
14					

Internal antenna, peak gain = 4.13dBi

AP7522 EU Domain 2.4 GHz Patch Antenna Maximum Conducted Transmit Power Settings

The following is a transmit power table (EU domain) per patch antenna in the 2.4 GHz band:

20 MHZ CHANNEL	40 MHZ CHANNEL	LEGACY DSSS RATES (1TX)	LEGACY OFDM RATES (1TX)	802.11n HT20 RATES/TURBO QAM (2TX)	802.11n HT40 RATES/TURBO QAM (2TX)
1		16.0	16.0	13.0	
2		16.0	16.0	13.0	
3	(1, 5)	16.0	16.0	13.0	13.0
4	(2, 6)	16.0	16.0	13.0	13.0
5	(3, 7)	16.0	16.0	13.0	13.0
6	(4, 8)	16.0	16.0	13.0	13.0
7	(5, 9)	16.0	16.0	13.0	13.0
8	(6, 10)	16.0	16.0	13.0	13.0
9	(7, 11)	16.0	16.0	13.0	13.0
10		16.0	16.0	13.0	13.0
11		16.0	16.0	13.0	13.0
12		16.0	16.0	13.0	13.0

20 MHZ CHANNEL	40 MHZ CHANNEL	LEGACY DSSS RATES (1TX)	LEGACY OFDM RATES (1TX)	802.11n HT20 RATES/TURBO QAM (2TX)	802.11n HT40 RATES/TURBO QAM (2TX)
13		16.0	16.0	13.0	
14					

Internal antenna, peak gain = 5dBi

AP7522 EU Regulatory Domain 5 GHz Band

AP7522 EU Domain 5 GHz External Dipole Antenna Model

The following is a transmit power table (EU domain) per external dipole antenna in the 5 GHz band:

20 MHZ CHANNEL	40 MHZ CHANNEL	80 MHZ CHANNELS	LEGACY OFDM RATES (1TX)	802.11n HT20 RATES (2TX)	802.11n HT40 RATES (2TX)	802.11n HT80 RATES (2TX)
36			19.0	16.0		
38	(36, 40)		19.0	16.0	16.0	
40			19.0	16.0		
42		(36, 40, 44, 48)	19.0	16.0		16.0
44			19.0	16.0		
46	(44, 48)		19.0	16.0	16.0	
48			19.0	16.0		
52			19.0	16.0		
54	(52, 56)		19.0	16.0	16.0	
56			19.0	16.0		
58		(52, 56, 60, 64)	19.0	16.0		16.0
60			19.0	16.0		
62	(60, 64)		19.0	16.0	16.0	
64			19.0	16.0		
100			20.0	20.0		
102	(100, 104)		20.0	20.0	20.0	
104			20.0	20.0		
106		(100, 104, 108, 112)	20.0	20.0		20.0
108			20.0	20.0		
110			20.0	20.0		
112			20.0	20.0		

20 MHZ CHANNEL	40 MHZ CHANNEL	80 MHZ CHANNELS	LEGACY OFDM RATES (1TX)	802.11n HT20 RATES (2TX)	802.11n HT40 RATES (2TX)	802.11n HT80 RATES (2TX)
114			20.0	20.0		
116			20.0	20.0		
118	(116, 120)		20.0	20.0	20.0	
120			20.0	20.0		
122		(116, 120, 124, 128)	20.0	20.0		20.0
124			20.0	20.0		
126	(124, 128)		20.0	20.0	20.0	
128			20.0	20.0		
130			20.0	20.0		
132			20.0	20.0		
134	(132, 136)		20.0	20.0	20.0	
136			20.0	20.0		
138			20.0	20.0		
140			20.0	20.0		
142			20.0	20.0	20.0	
144			20.0	20.0		
149						
151	(149, 153)					
153						
155		(149, 153, 157, 161)				
157						
159	(157, 161)					
161						
165						

External dipole antenna, peak gain = 7.3dBi

AP7522 EU Domain 5 GHz External Panel and Polarized-Panel Antenna Models

The following is a transmit power table (EU domain) per external panel or polarized-panel antenna in the 5 GHz band:



Note

The use of a panel antenna requires 1ft cable between the AP and the antenna element. If the antenna gain is 5.1 dB or less, the cable is not required.

20 MHZ CHANNEL	40 MHZ CHANNEL	80 MHZ CHANNELS	LEGACY OFDM RATES (1TX)	802.11n HT20 RATES (2TX)	802.11n HT40 RATES (2TX)	802.11n HT80 RATES (2TX)
36			20.0	17.0		
38	(36, 40)		20.0	17.0	17.0	
40			20.0	17.0		
42		(36, 40, 44, 48)	20.0	17.0		17.0
44			20.0	17.0		
46	(44, 48)		20.0	17.0	17.0	
48			20.0	17.0		
52			20.0	17.0		
54	(52, 56)		20.0	17.0	17.0	
56			20.0	17.0		
58		(52, 56, 60, 64)	20.0	17.0		17.0
60			20.0	17.0		
62	(60, 64)		20.0	17.0	17.0	
64			20.0	17.0		
100			20.0	20.0		
102	(100, 104)		20.0	20.0	20.0	
104			20.0	20.0		
106		(100, 104, 108, 112)	20.0	20.0		20.0
108			20.0	20.0		
110			20.0	20.0		
112			20.0	20.0		
114			20.0	20.0		
116			20.0	20.0		
118	(116, 120)		20.0	20.0	20.0	
120			20.0	20.0		
122		(116, 120, 124, 128)	20.0	20.0		20.0
124			20.0	20.0		
126	(124, 128)		20.0	20.0	20.0	
128			20.0	20.0		
130			20.0	20.0		
132			20.0	20.0		
134	(132, 136)		20.0	20.0	20.0	

20 MHZ CHANNEL	40 MHZ CHANNEL	80 MHZ CHANNELS	LEGACY OFDM RATES (1TX)	802.11n HT20 RATES (2TX)	802.11n HT40 RATES (2TX)	802.11n HT80 RATES (2TX)
136			20.0	20.0		
138			20.0	20.0		
140			20.0	20.0		
142			20.0	20.0	20.0	
144			20.0	20.0		
149						
151	(149, 153)					
153						
155		(149, 153, 157, 161)				
157						
159	(157, 161)					
161						
165						

External panel and polarized-panel antenna, peak gain = 6dBi

AP7522 EU Domain 5 GHz Internal Antenna Model

The following is a transmit power table (EU domain) per internal antenna in the 5 GHz band:

20 MHZ CHANNEL	40 MHZ CHANNEL	80 MHZ CHANNELS	LEGACY OFDM RATES (1TX)	802.11n HT20 RATES (2TX)	802.11n HT40 RATES (2TX)	802.11n HT80 RATES (2TX)
36			20.0	18.0		
38	(36, 40)		20.0	18.0	18.0	
40			20.0	18.0		
42		(36, 40, 44, 48)	20.0	18.0		18.0
44			20.0	18.0		
46	(44, 48)		20.0	18.0	18.0	
48			20.0	18.0		
52			20.0	18.0		
54	(52, 56)		20.0	18.0	18.0	
56			20.0	18.0		
58		(52, 56, 60, 64)	20.0	18.0		18.0
60			20.0	18.0		
62	(60, 64)		20.0	18.0	18.0	

20 MHZ CHANNEL	40 MHZ CHANNEL	80 MHZ CHANNELS	LEGACY OFDM RATES (1TX)	802.11n HT20 RATES (2TX)	802.11n HT40 RATES (2TX)	802.11n HT80 RATES (2TX)
64			20.0	18.0		
100			20.0	20.0		
102	(100, 104)		20.0	20.0	20.0	
104			20.0	20.0		
106		(100, 104, 108, 112)	20.0	20.0		20.0
108			20.0	20.0		
110			20.0	20.0		
112			20.0	20.0		
114			20.0	20.0		
116			20.0	20.0		
118	(116, 120)		20.0	20.0	20.0	
120			20.0	20.0		
122		(116, 120, 124, 128)	20.0	20.0		20.0
124			20.0	20.0		
126	(124, 128)		20.0	20.0	20.0	
128			20.0	20.0		
130			20.0	20.0		
132			20.0	20.0		
134	(132, 136)		20.0	20.0	20.0	
136			20.0	20.0		
138			20.0	20.0		
140			20.0	20.0		
142			20.0	20.0	20.0	
144			20.0	20.0		
149						
151	(149, 153)					
153						
155		(149, 153, 157, 161)				
157						
159	(157, 161)					
161						
165						

Internal antenna, peak gain = 5.92dBi

AP7522 EU Domain 5 GHz Patch Antenna Model

The following is a transmit power table (EU domain) per patch antenna in the 5 GHz band:

20 MHZ CHANNEL	40 MHZ CHANNEL	80 MHZ CHANNELS	LEGACY OFDM RATES (1TX)	802.11n HT20 RATES (2TX)	802.11n HT40 RATES (2TX)	802.11n HT80 RATES (2TX)
36			20.0	18.0		
38	(36, 40)		20.0	18.0	18.0	
40			20.0	18.0		
42		(36, 40, 44, 48)	20.0	18.0		18.0
44			20.0	18.0		
46	(44, 48)		20.0	18.0	18.0	
48			20.0	18.0		
52			20.0	18.0		
54	(52, 56)		20.0	18.0	18.0	
56			20.0	18.0		
58		(52, 56, 60, 64)	20.0	18.0		18.0
60			20.0	18.0		
62	(60, 64)		20.0	18.0	18.0	
64			20.0	18.0		
100			20.0	20.0		
102	(100, 104)		20.0	20.0	20.0	
104			20.0	20.0		
106		(100, 104, 108, 112)	20.0	20.0		20.0
108			20.0	20.0		
110			20.0	20.0		
112			20.0	20.0		
114			20.0	20.0		
116			20.0	20.0		
118	(116, 120)		20.0	20.0	20.0	
120			20.0	20.0		
122		(116, 120, 124, 128)	20.0	20.0		20.0
124			20.0	20.0		
126	(124, 128)		20.0	20.0	20.0	

20 MHZ CHANNEL	40 MHZ CHANNEL	80 MHZ CHANNELS	LEGACY OFDM RATES (1TX)	802.11n HT20 RATES (2TX)	802.11n HT40 RATES (2TX)	802.11n HT80 RATES (2TX)
128			20.0	20.0		
130			20.0	20.0		
132			20.0	20.0		
134	(132, 136)		20.0	20.0	20.0	
136			20.0	20.0		
138			20.0	20.0		
140			20.0	20.0		
142			20.0	20.0	20.0	
144			20.0	20.0		
149						
151	(149, 153)					
153						
155		(149, 153, 157, 161)				
157						
159	(157, 161)					
161						
165						

Patch antenna, peak gain = 5.4dBi

AP7522 Japan Regulatory Domain 2.4 GHz Band

AP7522 Japan Domain 2.4 GHz External Dipole Antenna Maximum Conducted Transmit Power Settings

The following is a transmit power table (Japan domain) per external dipole antenna in the 2.4 GHz band:

20 MHZ CHANNEL	40 MHZ CHANNEL	LEGACY DSSS RATES (1TX)	LEGACY OFDM RATES (1TX)	802.11n HT20 RATES/TURBO QAM (2TX)	802.11n HT40 RATES/TURBO QAM (2TX)
1		20.0	20.0	20.0	
2		20.0	20.0	20.0	
3	(1, 5)	20.0	20.0	20.0	20.0
4	(2, 6)	20.0	20.0	20.0	20.0
5	(3, 7)	20.0	20.0	20.0	20.0
6	(4, 8)	20.0	20.0	20.0	20.0

20 MHZ CHANNEL	40 MHZ CHANNEL	LEGACY DSSS RATES (1TX)	LEGACY OFDM RATES (1TX)	802.11n HT20 RATES/TURBO QAM (2TX)	802.11n HT40 RATES/TURBO QAM (2TX)
7	(5, 9)	20.0	20.0	20.0	20.0
8	(6, 10)	20.0	20.0	20.0	20.0
9	(7, 11)	20.0	20.0	20.0	20.0
10		20.0	20.0	20.0	20.0
11		20.0	20.0	20.0	20.0
12		20.0	20.0	20.0	20.0
13		20.0	20.0	20.0	20.0

Dipole antenna, peak gain = 3.17dBi

AP7522 Japan Domain 2.4 GHz External Panel Antenna Maximum Conducted Transmit Power Settings

The following is a transmit power table (Japan domain) per external panel antenna in the 2.4 GHz band:



Note

The use of this panel antenna requires 1ft cable between the AP and the antenna element. If the antenna gain is 5.1 dB or less, the cable is not required.

20 MHZ CHANNEL	40 MHZ CHANNEL	LEGACY DSSS RATES (1TX)	LEGACY OFDM RATES (1TX)	802.11n HT20 RATES/TURBO QAM (2TX)	802.11n HT40 RATES/TURBO QAM (2TX)
1		20.0	20.0	20.0	
2		20.0	20.0	20.0	
3	(1, 5)	20.0	20.0	20.0	20.0
4	(2, 6)	20.0	20.0	20.0	20.0
5	(3, 7)	20.0	20.0	20.0	20.0
6	(4, 8)	20.0	20.0	20.0	20.0
7	(5, 9)	20.0	20.0	20.0	20.0
8	(6, 10)	20.0	20.0	20.0	20.0
9	(7, 11)	20.0	20.0	20.0	20.0
10		20.0	20.0	20.0	20.0
11		20.0	20.0	20.0	20.0
12		20.0	20.0	20.0	20.0
13		20.0	20.0	20.0	20.0

Panel antenna, peak gain = 5.5dBi

AP7522 Japan Domain 2.4 GHz Internal Antenna Maximum Conducted Transmit Power Settings

The following is a transmit power table (Japan domain) per internal antenna in the 2.4 GHz band:

20 MHZ CHANNEL	40 MHZ CHANNEL	LEGACY DSSS RATES (1TX)	LEGACY OFDM RATES (1TX)	802.11n HT20 RATES/TURBO QAM (2TX)	802.11n HT40 RATES/TURBO QAM (2TX)
1		18.0	20.0	18.0	
2		18.0	20.0	18.0	
3	(1, 5)	18.0	20.0	18.0	18.0
4	(2, 6)	18.0	20.0	18.0	18.0
5	(3, 7)	18.0	20.0	18.0	18.0
6	(4, 8)	18.0	20.0	18.0	18.0
7	(5, 9)	18.0	20.0	18.0	18.0
8	(6, 10)	18.0	20.0	18.0	18.0
9	(7, 11)	18.0	20.0	18.0	18.0
10		18.0	20.0	18.0	18.0
11		18.0	20.0	18.0	18.0
12		18.0	20.0	18.0	
13		18.0	20.0	18.0	

Internal antenna, peak gain = 4.13dBi

AP7522 Japan Regulatory Domain 5 GHz Band

AP7522 Japan Domain 5 GHz External Dipole Antenna Model

The following is a transmit power table (Japan domain) per external dipole antenna in the 5 GHz band:

20 MHZ CHANNEL	40 MHZ CHANNEL	80 MHZ CHANNELS	LEGACY OFDM RATES (1TX)	802.11n HT20 RATES (2TX)	802.11n HT40 RATES (2TX)	802.11n HT80 RATES (2TX)
36			20.0	18.0		
38	(36, 40)		20.0	18.0	18.0	
40			20.0	18.0		
42		(36, 40, 44, 48)	20.0	18.0		18.0
44			20.0	18.0		
46	(44, 48)		20.0	18.0	18.0	
48			20.0	18.0		
52			20.0	18.0		

20 MHZ CHANNEL	40 MHZ CHANNEL	80 MHZ CHANNELS	LEGACY OFDM RATES (1TX)	802.11n HT20 RATES (2TX)	802.11n HT40 RATES (2TX)	802.11n HT80 RATES (2TX)
54	(52, 56)		20.0	18.0	18.0	
56			20.0	18.0		
58		(52, 56, 60, 64)	20.0	18.0		18.0
60			20.0	18.0		
62	(60, 64)		20.0	18.0	18.0	
64			20.0	18.0		
100			20.0	20.0		
102	(100, 104)		20.0	18.0	20.0	
104			20.0	20.0		
106		(100, 104, 108, 112)	20.0	20.0		20.0
108			20.0	20.0		
110			20.0	20.0		
112			20.0	20.0		
114			20.0	20.0		
116			20.0	20.0		
118	(116, 120)		20.0	20.0	20.0	
120			20.0	20.0		
122		(116, 120, 124, 128)	20.0	20.0		20.0
124			20.0	20.0		
126	(124, 128)		20.0	20.0	20.0	
128			20.0	20.0		
130			20.0	20.0		
132			20.0	20.0		
134	(132, 136)		20.0	20.0	20.0	
136			20.0	20.0		
138			20.0	20.0		
140			20.0	20.0		
142			20.0	20.0	20.0	
144			20.0	20.0		

External dipole antenna, peak gain = 5dBi

AP7522 Japan Domain 5 GHz External Panel Antenna Model

The following is a transmit power table (Japan domain) per external panel antenna in the 5 GHz band:



Note

The use of this panel antenna requires 1ft cable between the AP and the antenna element. If the antenna gain is 5.1 dB or less, the cable is not required.

20 MHZ CHANNEL	40 MHZ CHANNEL	80 MHZ CHANNELS	LEGACY OFDM RATES (ITX)	802.11n HT20 RATES (2TX)	802.11n HT40 RATES (2TX)	802.11n HT80 RATES (2TX)
36			20.0	17.0		
38	(36, 40)		20.0	17.0	17.0	
40			20.0	17.0		
42		(36, 40, 44, 48)	20.0	17.0		17.0
44			20.0	17.0		
46	(44, 48)		20.0	17.0	17.0	
48			20.0	17.0		
52			20.0	17.0		
54	(52, 56)		20.0	17.0	17.0	
56			20.0	17.0		
58		(52, 56, 60, 64)	20.0	17.0		17.0
60			20.0	17.0		
62	(60, 64)		20.0	17.0	17.0	
64			20.0	17.0		
100			20.0	20.0		
102	(100, 104)		20.0	17.0	20.0	
104			20.0	20.0		
106		(100, 104, 108, 112)	20.0	20.0		20.0
108			20.0	20.0		
110			20.0	20.0		
112			20.0	20.0		
114			20.0	20.0		
116			20.0	20.0		
118	(116, 120)		20.0	20.0	20.0	
120			20.0	20.0		
122		(116, 120, 124, 128)	20.0	20.0		20.0
124			20.0	20.0		

20 MHZ CHANNEL	40 MHZ CHANNEL	80 MHZ CHANNELS	LEGACY OFDM RATES (1TX)	802.11n HT20 RATES (2TX)	802.11n HT40 RATES (2TX)	802.11n HT80 RATES (2TX)
126	(124, 128)		20.0	20.0	20.0	
128			20.0	20.0		
130			20.0	20.0		
132			20.0	20.0		
134	(132, 136)		20.0	20.0	20.0	
136			20.0	20.0		
138			20.0	20.0		
140			20.0	20.0		
142			20.0	20.0	20.0	
144			20.0	20.0		

External dipole antenna, peak gain = 6dBi

AP7522 Japan Domain 5 GHz Internal Antenna Model

The following is a transmit power table (Japan domain) per internal antenna in the 5 GHz band:

20 MHZ CHANNEL	40 MHZ CHANNEL	80 MHZ CHANNELS	LEGACY OFDM RATES (1TX)	802.11n HT20 RATES (2TX)	802.11n HT40 RATES (2TX)	802.11n HT80 RATES (2TX)
36			17.0	14.0		
38	(36, 40)		17.0	14.0	14.0	
40			17.0	14.0		
42		(36, 40, 44, 48)	17.0	14.0		14.0
44			17.0	14.0		
46	(44, 48)		17.0	14.0	14.0	
48			17.0	14.0		
52			17.0	14.0		
54	(52, 56)		17.0	14.0	14.0	
56			17.0	14.0		
58		(52, 56, 60, 64)	17.0	14.0		14.0
60			17.0	14.0		
62	(60, 64)		17.0	14.0	14.0	
64			17.0	14.0		
100			20.0	20.0		
102	(100, 104)		17.0	14.0	20.0	

20 MHZ CHANNEL	40 MHZ CHANNEL	80 MHZ CHANNELS	LEGACY OFDM RATES (1TX)	802.11n HT20 RATES (2TX)	802.11n HT40 RATES (2TX)	802.11n HT80 RATES (2TX)
104			20.0	20.0		
106		(100, 104, 108, 112)	20.0	20.0		20.0
108			20.0	20.0		
110			20.0	20.0		
112			20.0	20.0		
114			20.0	20.0		
116			20.0	20.0		
118	(116, 120)		20.0	20.0	20.0	
120			20.0	20.0		
122		(116, 120, 124, 128)	20.0	20.0		20.0
124			20.0	20.0		
126	(124, 128)		20.0	20.0	20.0	
128			20.0	20.0		
130			20.0	20.0		
132			20.0	20.0		
134	(132, 136)		20.0	20.0	20.0	
136			20.0	20.0		
138			20.0	20.0		
140			20.0	20.0		
142			20.0	20.0	20.0	
144			20.0	20.0		

Internal antenna, peak gain = 5.92dBi

AP7522 NCC Domain

Refer to the following for an AP7522 antenna power table for the NCC domain.

2.4 GHz 2412 to 2462 MHz

	Antenna Gain (dBi)	Type	Max Conducted Power Settings (dBm)
ML-2452-APA2-01	3.17	Dipole	21
ML-2452-HPA5-036	3	Dipole	21
ML-2452-PNA5-01R	4.8	Panel	21

5.2 GHz 5250 to 5350 MHz

	Antenna Gain (dBi)	Type	Max Conducted Power Settings (dBm)
ML-2452-APA2-01	4.85	Dipole	15
ML-2452-HPA5-036	5	Dipole	15
ML-2452-PNA5-01R	5.1	Panel	15

5470 to 5725 MHz

	Antenna Gain (dBi)	Type	Max Conducted Power Settings (dBm)
ML-2452-APA2-01	4.85	Dipole	20
ML-2452-HPA5-036	5	Dipole	20
ML-2452-PNA5-01R	5.1	Panel	20

5725 to 5850 MHz

	Antenna Gain (dBi)	Type	Max Conducted Power Settings (dBm)
ML-2452-APA2-01	4.85	Dipole	21
ML-2452-HPA5-036	5	Dipole	21
ML-2452-PNA5-01R	5.1	Panel	21

24 AP7502 Regulatory Domains

AP7502 US Regulatory Domain 2.4 GHz Band
AP7502 US Regulatory Domain 5 GHz Band
AP 7502 EU Regulatory Domain 2.4 GHz Band
AP7502 EU Regulatory Domain 5 GHz Band
AP 7502 Japan Regulatory Domain 2.4 GHz Band
AP7502 Japan Regulatory Domain 5 GHz Band
AP7502 NCC Regulatory Domain 2.4 GHz Band
AP7502 NCC Regulatory Domain 5 GHz Band

AP7502 US Regulatory Domain 2.4 GHz Band

AP7502 US Domain 2.4 GHz Internal Antenna Maximum Conducted Transmit Power Settings

The following is a transmit power table (US domain) per internal antenna in the 2.4 GHz band:

20 MHZ CHANNEL	40 MHZ CHANNEL	LEGACY DSSS RATES (2TX)	LEGACY OFDM RATES (2TX)	802.11n HT20 RATES/TURBO QAM (2TX)	802.11n HT40 RATES/TURBO QAM (2TX)
1		18.0	11.5	9.5	
2		18.0	18.0	18.0	
3	(1, 5)	18.0	18.0	18.0	8.0
4	(2, 6)	18.0	18.0	18.0	11.0
5	(3, 7)	18.0	18.0	18.0	11.0
6	(4, 8)	18.0	18.0	18.0	11.0
7	(5, 9)	18.0	18.0	18.0	11.0
8	(6, 10)	18.0	18.0	18.0	11.0
9	(7, 11)	18.0	18.0	18.0	7.5
10		18.0	18.0	18.0	
11		18.0	9.5	9.5	

AP7502 US Regulatory Domain 5 GHz Band

AP7502 US Domain 5 GHz Internal Antenna Model

The following is a transmit power table (US domain) per internal antenna in the 5 GHz band:

20 MHZ CHANNEL	40 MHZ CHANNEL	80 MHZ CHANNELS	LEGACY OFDM RATES (2TX)	802.11n HT20 RATES (2TX)	802.11n HT40 RATES (2TX)	802.11n HT80 RATES (2TX)
36			13.5	12.5		
38	(36, 40)				7.0	
40			16.0	16.0		
42		(36, 40, 44, 48)				5.5
44			16.0	16.0		
46	(44, 48)				16.0	
48			16.0	16.0		
52			16.0	16.0		
54	(52, 56)				15.0	
56			16.0	16.0		
58		(52, 56, 60, 64)				7.0
60			16.0	16.0		
62	(60, 64)				9.5	
64			15.0	15.0		
100			16.0	15.0		
102	(100, 104)				8.5	
104			16.0	16.0		
106		(100, 104, 108, 112)				6.5
108			16.0	16.0		
110					15.0	
112			16.0	16.0		
114						
116			16.0	16.0		
118	(116, 120)					
120						
122		(116, 120, 124, 128)				
124						
126	(124, 128)					
128						
130						

20 MHZ CHANNEL	40 MHZ CHANNEL	80 MHZ CHANNELS	LEGACY OFDM RATES (2TX)	802.11n HT20 RATES (2TX)	802.11n HT40 RATES (2TX)	802.11n HT80 RATES (2TX)
132			16.0	16.0		
134	(132, 136)				15.0	
136			16.0	16.0		
138						
140			16.0	16.0		
142						
144						
149			14.0	14.0		
151	(149, 153)				9.5	
153			16.0	16.0		
155		(149, 153, 157, 161)				7.5
157			16.0	16.0		
159	(157, 161)				15.0	
161			16.0	16.0		
165			15.0	15.0		

AP 7502 EU Regulatory Domain 2.4 GHz Band

AP7502 EU Domain 2.4 GHz Internal Antenna Maximum Conducted Transmit Power Settings

The following is a transmit power table (EU domain) per internal antenna in the 2.4 GHz band:

20 MHZ CHANNEL	40 MHZ CHANNEL	LEGACY DSSS RATES (2TX)	LEGACY OFDM RATES (2TX)	802.11n HT20 RATES/TURBO QAM (2TX)	802.11n HT40 RATES/TURBO QAM (2TX)
1		16.5	18.0	18.0	
2		16.5	18.0	18.0	
3	(1, 5)	16.5	18.0	18.0	18.0
4	(2, 6)	16.5	18.0	18.0	18.0
5	(3, 7)	16.5	18.0	18.0	18.0
6	(4, 8)	16.5	18.0	18.0	18.0
7	(5, 9)	16.5	18.0	18.0	18.0
8	(6, 10)	16.5	18.0	18.0	18.0
9	(7, 11)	16.5	18.0	18.0	18.0
10		16.5	18.0	18.0	18.0

20 MHZ CHANNEL	40 MHZ CHANNEL	LEGACY DSSS RATES (2TX)	LEGACY OFDM RATES (2TX)	802.11n HT20 RATES/TURBO QAM (2TX)	802.11n HT40 RATES/TURBO QAM (2TX)
11		16.5	18.0	18.0	18.0
12		16.5	18.0	18.0	18.0
13		17.0	18.5	18.5	
14					

AP7502 EU Regulatory Domain 5 GHz Band

AP7502 EU Domain 5 GHz Internal Antenna Model

The following is a transmit power table (EU domain) per internal antenna in the 5 GHz band:

20 MHZ CHANNEL	40 MHZ CHANNEL	80 MHZ CHANNELS	LEGACY OFDM RATES (2TX)	802.11n HT20 RATES (2TX)	802.11n HT40 RATES (2TX)	802.11n HT80 RATES (2TX)
36			14.0	14.0		
38	(36, 40)				14.0	
40			15.0	15.0		
42		(36, 40, 44, 48)				14.5
44			15.0	15.0		
46	(44, 48)				15.0	
48			14.0	14.0		
52			11.5	11.5		
54	(52, 56)				12.0	
56			11.5	11.5		
58		(52, 56, 60, 64)				12.5
60			11.5	11.5		
62	(60, 64)				12.0	
64			11.0	11.5		
100			18.0	18.0		
102	(100, 104)				14.5	
104			18.0	18.0		
106		(100, 104, 108, 112)				14.0
108			18.0	18.0		
110					14.5	

20 MHZ CHANNEL	40 MHZ CHANNEL	80 MHZ CHANNES	LEGACY OFDM RATES (2TX)	802.11n HT20 RATES (2TX)	802.11n HT40 RATES (2TX)	802.11n HT80 RATES (2TX)
112			18.0	18.0		
114						
116			18.0	18.0		
118	(116, 120)				14.5	
120			18.0	18.0		
122		(116, 120, 124, 128)				14.0
124			18.0	18.0		
126	(124, 128)				15.0	
128			18.0	18.0		
130						
132			18.0	18.0		
134	(132, 136)				15.0	
136			18.0	18.0		
138						
140			18.0	18.0		
142						
144						
149						
151	(149, 153)					
153						
155		(149, 153, 157, 161)				
157						
159	(157, 161)					
161						
165						

AP 7502 Japan Regulatory Domain 2.4 GHz Band

AP7502 Japan Domain 2.4 GHz Internal Antenna Maximum Conducted Transmit Power Settings

The following is a transmit power table (Japan domain) per internal antenna in the 2.4 GHz band:

20 MHZ CHANNEL	40 MHZ CHANNEL	LEGACY DSSS RATES (2TX)	LEGACY OFDM RATES (2TX)	802.11n HT20 RATES/TURBO QAM (2TX)	802.11n HT40 RATES/TURBO QAM (2TX)
1		13.0	17.0	14.0	
2		13.0	17.0	14.0	
3	(1, 5)	13.0	17.0	14.0	14.0
4	(2, 6)	13.0	17.0	14.0	14.0
5	(3, 7)	13.0	17.0	14.0	14.0
6	(4, 8)	13.0	17.0	14.0	14.0
7	(5, 9)	13.0	17.0	14.0	14.0
8	(6, 10)	13.0	17.0	14.0	14.0
9	(7, 11)	13.0	17.0	14.0	14.0
10		13.0	17.0	14.0	14.0
11		13.0	17.0	14.0	14.0
12		13.0	17.0	14.0	14.0
13		13.0	17.0	14.0	
14					

AP7502 Japan Regulatory Domain 5 GHz Band

AP7502 Japan Domain 5 GHz Internal Antenna Model

The following is a transmit power table (Japan domain) per internal antenna in the 5 GHz band:

20 MHZ CHANNEL	40 MHZ CHANNEL	80 MHZ CHANNELS	LEGACY OFDM RATES (2TX)	802.11n HT20 RATES (2TX)	802.11n HT40 RATES (2TX)	802.11n HT80 RATES (2TX)
36			14.0	11.0		
38	(36, 40)				11.0	
40			14.0	11.0		
42		(36, 40, 44, 48)				12.0
44			14.0	11.0		
46	(44, 48)				11.0	
48			14.0	11.0		
52			14.0	11.0		
54	(52, 56)				11.0	
56			14.0	11.0		
58		(52, 56, 60, 64)				12.0

20 MHZ CHANNEL	40 MHZ CHANNEL	80 MHZ CHANNELS	LEGACY OFDM RATES (2TX)	802.11n HT20 RATES (2TX)	802.11n HT40 RATES (2TX)	802.11n HT80 RATES (2TX)
60			14.0	11.0		
62	(60, 64)				11.0	
64			14.0	11.0		
100			18,0	18,0		
102	(100, 104)				17.0	
104			18,0	18,0		
106		(100, 104, 108, 112)				17.0
108			18,0	18,0		
110					17.0	
112			18,0	18,0		
114						
116			18,0	18,0		
118	(116, 120)				17.0	
120			18,0	18,0		
122		(116, 120, 124, 128)				17.0
124			18,0	18,0		
126	(124, 128)				17.0	
128			18,0	18,0		
130						
132			18,0	18,0		
134	(132, 136)				17.0	
136			18,0	18,0		
138						
140			18,0	18,0		
142						
144						
149						
151	(149, 153)					
153						
155		(149, 153, 157, 161)				
157						
159	(157, 161)					

20 MHZ CHANNEL	40 MHZ CHANNEL	80 MHZ CHANNELS	LEGACY OFDM RATES (2TX)	802.11n HT20 RATES (2TX)	802.11n HT40 RATES (2TX)	802.11n HT80 RATES (2TX)
161						
165						

AP7502 NCC Regulatory Domain 2.4 GHz Band

AP7502 NCC Domain 2.4 GHz Internal Antenna Maximum Conducted Transmit Power Settings

The following is a transmit power table (NCC domain) per internal antenna in the 2.4 GHz band:

20 MHZ CHANNEL	40 MHZ CHANNEL	LEGACY DSSS RATES (2TX)	LEGACY OFDM RATES (2TX)	802.11n HT20 RATES/TURBO QAM (2TX)	802.11n HT40 RATES/TURBO QAM (2TX)
1		18.0	11.5	9.5	
2		18.0	18.0	18.0	
3	(1, 5)	18.0	18.0	18.0	8.0
4	(2, 6)	18.0	18.0	18.0	11.0
5	(3, 7)	18.0	18.0	18.0	11.0
6	(4, 8)	18.0	18.0	18.0	11.0
7	(5, 9)	18.0	18.0	18.0	11.0
8	(6, 10)	18.0	18.0	18.0	11.0
9	(7, 11)	18.0	18.0	18.0	7.5
10		18.0	18.0	18.0	
11		18.0	9.5	9.5	

AP7502 NCC Regulatory Domain 5 GHz Band

AP7502 NCC Domain 5 GHz Internal Antenna Model

The following is a transmit power table (NCC domain) per internal antenna in the 5 GHz band:

20 MHZ CHANNEL	40 MHZ CHANNEL	80 MHZ CHANNELS	LEGACY OFDM RATES (2TX)	802.11n HT20 RATES (2TX)	802.11n HT40 RATES (2TX)	802.11n HT80 RATES (2TX)
36						
38	(36, 40)					
40						

20 MHZ CHANNEL	40 MHZ CHANNEL	80 MHZ CHANNELS	LEGACY OFDM RATES (2TX)	802.11n HT20 RATES (2TX)	802.11n HT40 RATES (2TX)	802.11n HT80 RATES (2TX)
42		(36, 40, 44, 48)				
44						
46	(44, 48)					
48						
52						
54	(52, 56)					
56			10.0	10.0		
58		(52, 56, 60, 64)				
60			10.0	10.0		
62	(60, 64)				9.5	
64			9.5	9.5		
100			16.0	15.0		
102	(100, 104)				8.5	
104			16.0	16.0		
106		(100, 104, 108, 112)				6.5
108			16.0	16.0		
110					16.0	
112			16.0	16.0		
114						
116			16.0	16.0		
118	(116, 120)					
120						
122		(116, 120, 124, 128)				
124						
126	(124, 128)					
128						
130						
132			16.0	16.0		
134	(132, 136)				15.0	
136			16.0	16.0		
138						
140			16.0	13.5		

20 MHZ CHANNEL	40 MHZ CHANNEL	80 MHZ CHANNELS	LEGACY OFDM RATES (2TX)	802.11n HT20 RATES (2TX)	802.11n HT40 RATES (2TX)	802.11n HT80 RATES (2TX)
142						
144						
149			16.0	16.0		
151	(149, 153)				15.0	
153			16.0	16.0		
155		(149, 153, 157, 161)				14.0
157			16.0	16.0		
159	(157, 161)				15.0	
161			16.0	16.0		
165			16.0	16.0		

25 AP7562 Regulatory Domains

AP7562 US Regulatory Domain 2.4 GHz Band
 AP7562 US Regulatory Domain 5 GHz Band
 AP7562 EU Regulatory Domain 2.4 GHz Band
 AP7562 EU Regulatory Domain 5 GHz Band
 AP7562 Japan Regulatory Domain 2.4 GHz Band
 AP7562 Japan Regulatory Domain 5 GHz Band
 AP7562 NCC Domain

AP7562 US Regulatory Domain 2.4 GHz Band

AP7562 US Domain 2.4 GHz Dipole Antenna Maximum Conducted Transmit Power Setting

The following is a transmit power table (US domain) per internal antenna in the 2.4 GHz band:

20 MHZ CHANNEL	40 MHZ CHANNEL	LEGACY DSSS RATES (1TX)	LEGACY OFDM RATES (1TX)	802.11n HT20 RATES/TURBO QAM (3TX)	802.11n HT40 RATES/TURBO QAM (3TX)
1		20.0	15.0	11.0	
2		21.0	20.0	20.0	
3	(1, 5)	21.0	20.0	20.0	10.0
4	(2, 6)	21.0	20.0	20.0	14.0
5	(3, 7)	21.0	20.0	20.0	14.0
6	(4, 8)	21.0	20.0	20.0	14.0
7	(5, 9)	21.0	20.0	20.0	14.0
8	(6, 10)	21.0	20.0	20.0	14.0
9	(7, 11)	21.0	20.0	20.0	14.0
10		21.0	20.0	20.0	
11		21.0	16.0	15.0	

Dipole antenna, peak gain = 5.3dBi

AP7562 US Domain 2.4 GHz Panel Antenna Maximum Conducted Transmit Power Settings

The following is a transmit power table (US domain) per panel antenna in the 2.4 GHz band:

20 MHZ CHANNEL	40 MHZ CHANNEL	LEGACY DSSS RATES (1TX)	LEGACY OFDM RATES (1TX)	802.11n HT20 RATES/TURBO QAM (3TX)	802.11n HT40 RATES/TURBO QAM (3TX)
1		20.0	16.0	14.0	
2		21.0	21.0	20.0	
3	(1, 5)	21.0	21.0	20.0	13.0
4	(2, 6)	21.0	21.0	20.0	14.0
5	(3, 7)	21.0	21.0	20.0	14.0
6	(4, 8)	21.0	21.0	20.0	14.0
7	(5, 9)	21.0	21.0	20.0	14.0
8	(6, 10)	21.0	21.0	20.0	14.0
9	(7, 11)	21.0	21.0	20.0	12.0
10		21.0	21.0	20.0	
11		20.0	16.0	18.0	

Panel antenna, peak gain = 6.5 dBi

AP7562 US Domain 2.4 GHz Polarized-Panel Antenna Maximum Conducted Transmit Power Settings

The following is a transmit power table (US domain) per polarized-panel antenna in the 2.4 GHz band:

20 MHZ CHANNEL	40 MHZ CHANNEL	LEGACY DSSS RATES (1TX)	LEGACY OFDM RATES (1TX)	802.11n HT20 RATES/TURBO QAM (3TX)	802.11n HT40 RATES/TURBO QAM (3TX)
1		20.0	16.0	13.0	
2		21.0	20.0	18.0	
3	(1, 5)	21.0	20.0	18.0	12.0
4	(2, 6)	21.0	20.0	18.0	14.0
5	(3, 7)	21.0	20.0	18.0	14.0
6	(4, 8)	21.0	20.0	18.0	14.0
7	(5, 9)	21.0	20.0	18.0	14.0
8	(6, 10)	21.0	20.0	18.0	14.0
9	(7, 11)	21.0	20.0	18.0	12.0
10		21.0	20.0	18.0	
11		20.0	17.0	14.0	

Polarized-panel antenna, peak gain = 9.5 dBi

AP7562 US Domain 2.4 GHz Facade Antenna Maximum Conducted Transmit Power Settings

The following is a transmit power table (US domain) per facade antenna in the 2.4 GHz band:

20 MHZ CHANNEL	40 MHZ CHANNEL	LEGACY DSSS RATES (1TX)	LEGACY OFDM RATES (1TX)	802.11n HT20 RATES/TURBO QAM (3TX)	802.11n HT40 RATES/TURBO QAM (3TX)
1		21.0	16.0	12.0	
2		21.0	21.0	21.0	
3	(1, 5)	21.0	21.0	21.0	11.0
4	(2, 6)	21.0	21.0	21.0	15.0
5	(3, 7)	21.0	21.0	21.0	15.0
6	(4, 8)	21.0	21.0	21.0	15.0
7	(5, 9)	21.0	21.0	21.0	15.0
8	(6, 10)	21.0	21.0	21.0	15.0
9	(7, 11)	21.0	21.0	21.0	15.0
10		21.0	21.0	21.0	
11		21.0	17.0	16.0	

Facade antenna, peak gain = 4.8 dBi

AP7562 US Regulatory Domain 5 GHz Band

AP7562 US Domain 5 GHz Dipole Antenna Model

The following is a transmit power table (US domain) per dipole antenna in the 5 GHz band:

20 MHZ CHANNEL	40 MHZ CHANNEL	80 MHZ CHANNELS	LEGACY OFDM RATES (1TX)	802.11n HT20 RATES (3TX)	802.11n HT40 RATES (3TX)	802.11n HT80 RATES (3TX)
36			16.0	12.0		
38	(36, 40)		16.0	12.0	12.0	
40			16.0	12.0		
42		(36, 40, 44, 48)	16.0	12.0		12.0
44			16.0	12.0		
46	(44, 48)		16.0	12.0	12.0	
48			16.0	12.0		
52			20.0	14.0		
54	(52, 56)		20.0	14.0	17.0	
56			20.0	14.0		

20 MHZ CHANNEL	40 MHZ CHANNEL	80 MHZ CHANNELS	LEGACY OFDM RATES (1TX)	802.11n HT20 RATES (3TX)	802.11n HT40 RATES (3TX)	802.11n HT80 RATES (3TX)
58		(52, 56, 60, 64)	20.0	14.0		9.0
60			20.0	14.0		
62	(60, 64)		20.0	14.0	17.0	
64			19.0	14.0		
100			18.0	14.0		
102	(100, 104)		20.0	14.0	13.0	
104			20.0	14.0		
106		(100, 104, 108, 112)	20.0	14.0		11.0
108			20.0	14.0		
110			20.0	14.0	15.0	
112			20.0	14.0		
114			20.0	14.0		
116			20.0	14.0		
118	(116, 120)		20.0	14.0	15.0	
120			20.0	14.0		
122		(116, 120, 124, 128)	20.0	14.0		19.0
124			20.0	14.0		
126	(124, 128)		20.0	14.0	15.0	
128			20.0	14.0		
130			20.0	14.0		
132			20.0	14.0		
134	(132, 136)		20.0	14.0	16.0	
136			20.0	14.0		
138			20.0	14.0		
140			18.0	14.0		
142			18.0	14.0	17.0	
144			20.0	14.0		
149			17.0	17.0		
151	(149, 153)		20.0	20.0	15.0	
153			20.0	20.0		
155		(149, 153, 157, 161)	20.0	20.0		15.0
157			20.0	20.0		

20 MHZ CHANNEL	40 MHZ CHANNEL	80 MHZ CHANNELS	LEGACY OFDM RATES (1TX)	802.11n HT20 RATES (3TX)	802.11n HT40 RATES (3TX)	802.11n HT80 RATES (3TX)
159	(157, 161)		20.0	20.0	18.0	
161			20.0	20.0		
165			18.0	17.0		

Dipole antenna, peak gain = 7.3 dBi

For indoor placement, the power can be set as high as 20dBm

AP7562 US Domain 5 GHz Panel Antenna Model

The following is a transmit power table (US domain) per panel antenna in the 5 GHz band:

20 MHZ CHANNEL	40 MHZ CHANNEL	80 MHZ CHANNELS	LEGACY OFDM RATES (1TX)	802.11n HT20 RATES (3TX)	802.11n HT40 RATES (3TX)	802.11n HT80 RATES (3TX)
36			20.0	19.0		
38	(36, 40)		20.0	20.0	16.0	
40			20.0	20.0		
42		(36, 40, 44, 48)	20.0	20.0		14.0
44			20.0	20.0		
46	(44, 48)		20.0	20.0	20.0	
48			20.0	20.0		
52			20.0	16.0		
54	(52, 56)		20.0	16.0	18.0	
56			20.0	16.0		
58		(52, 56, 60, 64)	20.0	16.0		11.0
60			20.0	16.0		
62	(60, 64)		20.0	16.0	18.0	
64			19.0	16.0		
100			18.0	16.0		
102	(100, 104)		20.0	16.0	14.0	
104			20.0	16.0		
106		(100, 104, 108, 112)	20.0	16.0		11.0
108			20.0	16.0		
110			20.0	16.0	19.0	
112			20.0	16.0		

20 MHZ CHANNEL	40 MHZ CHANNEL	80 MHZ CHANNELS	LEGACY OFDM RATES (1TX)	802.11n HT20 RATES (3TX)	802.11n HT40 RATES (3TX)	802.11n HT80 RATES (3TX)
114			20.0	16.0		
116			20.0	16.0		
118	(116, 120)		20.0	16.0	19.0	
120			20.0	16.0		
122		(116, 120, 124, 128)	20.0	16.0		19.0
124			20.0	16.0		
126	(124, 128)		20.0	16.0	19.0	
128			20.0	16.0		
130			20.0	16.0		
132			20.0	16.0		
134	(132, 136)		20.0	16.0	17.0	
136			20.0	16.0		
138			20.0	16.0		
140			18.0	16.0		
142			18.0	16.0	19.0	
144			20.0	16.0		
149			17.0	15.0		
151	(149, 153)		20.0	20.0	14.0	
153			20.0	20.0		
155		(149, 153, 157, 161)	20.0	20.0		15.0
157			20.0	20.0		
159	(157, 161)		20.0	20.0	15.0	
161			20.0	20.0		
165			18.0	16.0		

Panel antenna, peak gain = 6 dBi

AP7562 US Domain 5 GHz Polarized-Panel Antenna Model

The following is a transmit power table (US domain) per polarized-panel antenna in the 5 GHz band:

20 MHZ CHANNEL	40 MHZ CHANNEL	80 MHZ CHANNELS	LEGACY OFDM RATES (1TX)	802.11n HT20 RATES (3TX)	802.11n HT40 RATES (3TX)	802.11n HT80 RATES (3TX)
36			19.0	18.0		
38	(36, 40)		20.0	20.0	15.0	

20 MHZ CHANNEL	40 MHZ CHANNEL	80 MHZ CHANNELS	LEGACY OFDM RATES (1TX)	802.11n HT20 RATES (3TX)	802.11n HT40 RATES (3TX)	802.11n HT80 RATES (3TX)
40			20.0	20.0		
42		(36, 40, 44, 48)	20.0	20.0		11.0
44			20.0	20.0		
46	(44, 48)		20.0	20.0	19.0	
48			20.0	20.0		
52			20.0	17.0		
54	(52, 56)		20.0	17.0	18.0	
56			20.0	17.0		
58		(52, 56, 60, 64)	20.0	17.0		11.0
60			20.0	17.0		
62	(60, 64)		20.0	17.0	18.0	
64			19.0	17.0		
100			18.0	17.0		
102	(100, 104)		20.0	17.0	14.0	
104			20.0	17.0		
106		(100, 104, 108, 112)	20.0	17.0		12.0
108			20.0	17.0		
110			20.0	17.0	18.0	
112			20.0	17.0		
114			20.0	17.0		
116			20.0	17.0		
118	(116, 120)		20.0	17.0	18.0	
120			20.0	17.0		
122		(116, 120, 124, 128)	20.0	17.0		18.0
124			20.0	17.0		
126	(124, 128)		20.0	17.0	18.0	
128			20.0	17.0		
130			20.0	17.0		
132			20.0	17.0		
134	(132, 136)		20.0	17.0	17.0	
136			20.0	17.0		
138			20.0	17.0		

20 MHZ CHANNEL	40 MHZ CHANNEL	80 MHZ CHANNELS	LEGACY OFDM RATES (1TX)	802.11n HT20 RATES (3TX)	802.11n HT40 RATES (3TX)	802.11n HT80 RATES (3TX)
140			17.0	15.0		
142			17.0	15.0	17.0	
144			20.0	17.0		
149			16.0	15.0		
151	(149, 153)		20.0	20.0	13.0	
153			20.0	20.0		
155		(149, 153, 157, 161)	20.0	20.0		12.0
157			20.0	20.0		
159	(157, 161)		20.0	20.0	15.0	
161			20.0	20.0		
165			17.0	16.0		

Polarized-panel antenna, peak gain = 9.2 dBi

AP7562 US Domain 5 GHz Facade Antenna Model

The following is a transmit power table (US domain) per facade antenna in the 5 GHz band:

20 MHZ CHANNEL	40 MHZ CHANNEL	80 MHZ CHANNELS	LEGACY OFDM RATES (1TX)	802.11n HT20 RATES (3TX)	802.11n HT40 RATES (3TX)	802.11n HT80 RATES (3TX)
36			19.0	18.0		
38	(36, 40)		20.0	20.0	15.0	
40			20.0	20.0		
42		(36, 40, 44, 48)	20.0	20.0		11.0
44			20.0	20.0		
46	(44, 48)		20.0	20.0	19.0	
48			20.0	20.0		
52			20.0	17.0		
54	(52, 56)		20.0	17.0	18.0	
56			20.0	17.0		
58		(52, 56, 60, 64)	20.0	17.0		11.0
60			20.0	17.0		
62	(60, 64)		20.0	17.0	18.0	
64			19.0	17.0		
100			18.0	17.0		

20 MHZ CHANNEL	40 MHZ CHANNEL	80 MHZ CHANNELS	LEGACY OFDM RATES (1TX)	802.11n HT20 RATES (3TX)	802.11n HT40 RATES (3TX)	802.11n HT80 RATES (3TX)
102	(100, 104)		20.0	17.0	14.0	
104			20.0	17.0		
106		(100, 104, 108, 112)	20.0	17.0		12.0
108			20.0	17.0		
110			20.0	17.0	18.0	
112			20.0	17.0		
114			20.0	17.0		
116			20.0	17.0		
118	(116, 120)		20.0	17.0	18.0	
120			20.0	17.0		
122		(116, 120, 124, 128)	20.0	17.0		18.0
124			20.0	17.0		
126	(124, 128)		20.0	17.0	18.0	
128			20.0	17.0		
130			20.0	17.0		
132			20.0	17.0		
134	(132, 136)		20.0	17.0	17.0	
136			20.0	17.0		
138			20.0	17.0		
140			17.0	15.0		
142			17.0	15.0	17.0	
144			20.0	17.0		
149			16.0	15.0		
151	(149, 153)		20.0	20.0	13.0	
153			20.0	20.0		
155		(149, 153, 157, 161)	20.0	20.0		12.0
157			20.0	20.0		
159	(157, 161)		20.0	20.0	15.0	
161			20.0	20.0		
165			17.0	16.0		

Facade antenna, peak gain = 6.4 dBi

AP7562 EU Regulatory Domain 2.4 GHz Band

AP7562 EU Domain 2.4 GHz Dipole Antenna Maximum Conducted Transmit Power Settings

The following is a transmit power table (EU domain) per dipole antenna in the 2.4 GHz band:

20 MHZ CHANNEL	40 MHZ CHANNEL	LEGACY DSSS RATES (1TX)	LEGACY OFDM RATES (1TX)	802.11n HT20 RATES/TURBO QAM (3TX)	802.11n HT40 RATES/TURBO QAM (3TX)
1		8.5	9.5	4.5	
2		8.5	9.5	4.5	
3	(1, 5)	8.5	9.5	4.5	4.5
4	(2, 6)	8.5	9.5	4.5	4.5
5	(3, 7)	8.5	9.5	4.5	4.5
6	(4, 8)	8.5	9.5	4.5	4.5
7	(5, 9)	8.5	9.5	4.5	4.5
8	(6, 10)	8.5	9.5	4.5	4.5
9	(7, 11)	8.5	9.5	4.5	4.5
10		8.5	9.5	4.5	4.5
11		8.5	9.5	4.5	4.5
12		8.5	9.5	4.5	
13		8.5	9.5	4.5	

Dipole antenna, peak gain = 10.5 dBi

AP7562 EU Domain 2.4 GHz Panel Antenna Maximum Conducted Transmit Power Settings

The following is a transmit power table (EU domain) per panel antenna in the 2.4 GHz band:

20 MHZ CHANNEL	40 MHZ CHANNEL	LEGACY DSSS RATES (1TX)	LEGACY OFDM RATES (1TX)	802.11n HT20 RATES/TURBO QAM (3TX)	802.11n HT40 RATES/TURBO QAM (3TX)
1		11.0	12.0	7.0	
2		11.0	12.0	7.0	
3	(1, 5)	11.0	12.0	7.0	7.0
4	(2, 6)	11.0	12.0	7.0	7.0
5	(3, 7)	11.0	12.0	7.0	7.0
6	(4, 8)	11.0	12.0	7.0	7.0
7	(5, 9)	11.0	12.0	7.0	7.0

20 MHZ CHANNEL	40 MHZ CHANNEL	LEGACY DSSS RATES (1TX)	LEGACY OFDM RATES (1TX)	802.11n HT20 RATES/TURBO QAM (3TX)	802.11n HT40 RATES/TURBO QAM (3TX)
8	(6, 10)	11.0	12.0	7.0	7.0
9	(7, 11)	11.0	12.0	7.0	7.0
10		11.0	12.0	7.0	7.0
11		11.0	12.0	7.0	7.0
12		11.0	12.0	7.0	7.0
13		11.0	12.0	7.0	7.0

Panel antenna, peak gain = 8 dBi

AP7562 EU Domain 2.4 GHz Polarized-Panel Antenna Maximum Conducted Transmit Power Settings

The following is a transmit power table (EU domain) per polarized panel antenna in the 2.4 GHz band:

20 MHZ CHANNEL	40 MHZ CHANNEL	LEGACY DSSS RATES (1TX)	LEGACY OFDM RATES (1TX)	802.11n HT20 RATES/TURBO QAM (3TX)	802.11n HT40 RATES/TURBO QAM (3TX)
1		9.5	10.5	5.5	
2		9.5	10.5	5.5	
3	(1, 5)	9.5	10.5	5.5	5.5
4	(2, 6)	9.5	10.5	5.5	5.5
5	(3, 7)	9.5	10.5	5.5	5.5
6	(4, 8)	9.5	10.5	5.5	5.5
7	(5, 9)	9.5	10.5	5.5	5.5
8	(6, 10)	9.5	10.5	5.5	5.5
9	(7, 11)	9.5	10.5	5.5	5.5
10		9.5	10.5	5.5	5.5
11		9.5	10.5	5.5	5.5
12		9.5	10.5	5.5	5.5
13		9.5	10.5	5.5	5.5

Polarized panel antenna, peak gain = 9.5 dBi

AP7562 EU Regulatory Domain 5 GHz Band

AP7562 EU Domain 5 GHz Dipole Antenna Model

The following is a transmit power table (EU domain) per dipole antenna in the 5 GHz band:

20 MHZ CHANNEL	40 MHZ CHANNEL	80 MHZ CHANNELS	LEGACY OFDM RATES (1TX)	802.11n HT20 RATES (3TX)	802.11n HT40 RATES (3TX)	802.11n HT80 RATES (3TX)
36			12.5	7.5		
38	(36, 40)		12.5	7.5	7.5	
40			12.5	7.5		
42		(36, 40, 44, 48)	12.5	7.5		7.5
44			12.5	7.5		
46	(44, 48)		12.5	7.5	7.5	
48			12.5	7.5		
52			12.5	7.5		
54	(52, 56)		12.5	7.5	7.5	
56			12.5	7.5		
58		(52, 56, 60, 64)	12.5	7.5		7.5
60			12.5	7.5		
62	(60, 64)		12.5	7.5	7.5	
64			12.5	7.5		
100			19.5	14.5		
102	(100, 104)		19.5	14.5	14.5	
104			19.5	14.5		
106		(100, 104, 108, 112)	19.5	14.5		14.5
108			19.5	14.5		
110			19.5	14.5	14.5	
112			19.5	14.5		
114			19.5	14.5		
116			19.5	14.5		
118	(116, 120)		19.5	14.5	14.5	
120			19.5	14.5		
122		(116, 120, 124, 128)	19.5	14.5		14.5
124			19.5	14.5		
126	(124, 128)		19.5	14.5	14.5	
128			19.5	14.5		
130			19.5	14.5		
132			19.5	14.5		
134	(132, 136)		19.5	14.5	14.5	

20 MHZ CHANNEL	40 MHZ CHANNEL	80 MHZ CHANNELS	LEGACY OFDM RATES (1TX)	802.11n HT20 RATES (3TX)	802.11n HT40 RATES (3TX)	802.11n HT80 RATES (3TX)
136			19.5	14.5		
138			19.5	14.5		
140			19.5	14.5		
142			19.5	14.5	14.5	
144			19.5	14.5		

Dipole antenna, peak gain = 10.5 dBi

AP7562 EU Domain 5 GHz Panel Antenna Model

The following is a transmit power table (EU domain) per panel antenna in the 5 GHz band:

20 MHZ CHANNEL	40 MHZ CHANNEL	80 MHZ CHANNELS	LEGACY OFDM RATES (1TX)	802.11n HT20 RATES (3TX)	802.11n HT40 RATES (3TX)	802.11n HT80 RATES (3TX)
36			11.0	6.0		
38	(36, 40)		11.0	6.0	6.0	
40			11.0	6.0		
42		(36, 40, 44, 48)	11.0	6.0		6.0
44			11.0	6.0		
46	(44, 48)		11.0	6.0	6.0	
48			11.0	6.0		
52			11.0	6.0		
54	(52, 56)		11.0	6.0	6.0	
56			11.0	6.0		
58		(52, 56, 60, 64)	11.0	6.0		6.0
60			11.0	6.0		
62	(60, 64)		11.0	6.0	6.0	
64			11.0	6.0		
100			18.0	13.0		
102	(100, 104)		19.5	13.0	13.0	
104			18.0	13.0		
106		(100, 104, 108, 112)	18.0	13.0		13.0
108			18.0	13.0		
110			18.0	13.0	13.0	
112			18.0	13.0		

20 MHZ CHANNEL	40 MHZ CHANNEL	80 MHZ CHANNELS	LEGACY OFDM RATES (1TX)	802.11n HT20 RATES (3TX)	802.11n HT40 RATES (3TX)	802.11n HT80 RATES (3TX)
114			18.0	13.0		
116			18.0	13.0		
118	(116, 120)		18.0	13.0	13.0	
120			18.0	13.0		
122		(116, 120, 124, 128)	18.0	13.0		13.0
124			18.0	13.0		
126	(124, 128)		18.0	13.0	13.0	
128			18.0	13.0		
130			18.0	13.0		
132			18.0	13.0		
134	(132, 136)		18.0	13.0	13.0	
136			18.0	13.0		
138			18.0	13.0		
140			18.0	13.0		
142			18.0	13.0	13.0	
144			18.0	13.0		

Panel antenna, peak gain = 12 dBi

AP7562 EU Domain 5 GHz Polarized-Panel Antenna Model

The following is a transmit power table (EU domain) per polarized-panel antenna in the 5 GHz band:

20 MHZ CHANNEL	40 MHZ CHANNEL	80 MHZ CHANNELS	LEGACY OFDM RATES (1TX)	802.11n HT20 RATES (3TX)	802.11n HT40 RATES (3TX)	802.11n HT80 RATES (3TX)
36			13.5	9.0		
38	(36, 40)		13.5	9.0	9.0	
40			13.5	9.0		
42		(36, 40, 44, 48)	13.5	9.0		9.0
44			13.5	9.0		
46	(44, 48)		13.5	9.0	9.0	
48			13.5	9.0		
52			13.5	9.0		
54	(52, 56)		13.5	9.0	9.0	
56			13.5	9.0		

20 MHZ CHANNEL	40 MHZ CHANNEL	80 MHZ CHANNELS	LEGACY OFDM RATES (1TX)	802.11n HT20 RATES (3TX)	802.11n HT40 RATES (3TX)	802.11n HT80 RATES (3TX)
58		(52, 56, 60, 64)	13.5	9.0		9.0
60			13.5	9.0		
62	(60, 64)		13.5	9.0	9.0	
64			13.5	9.0		
100			20.0	16.0		
102	(100, 104)		20.0	16.0	16.0	
104			20.0	16.0		
106		(100, 104, 108, 112)	20.0	16.0		16.0
108			20.0	16.0		
110			20.0	16.0	16.0	
112			20.0	16.0		
114			20.0	16.0		
116			20.0	16.0		
118	(116, 120)		20.0	16.0	16.0	
120			20.0	16.0		
122		(116, 120, 124, 128)	20.0	16.0		16.0
124			20.0	16.0		
126	(124, 128)		20.0	16.0	16.0	
128			20.0	16.0		
130			20.0	16.0		
132			20.0	16.0		
134	(132, 136)		20.0	16.0	16.0	
136			20.0	16.0		
138			20.0	16.0		
140			20.0	16.0		
142			20.0	16.0	16.0	
144			20.0	16.0		

Polarized panel antenna, peak gain = 9.2dBi

AP7562 Japan Regulatory Domain 2.4 GHz Band

AP7562 Japan Domain 2.4 GHz Dipole Antenna Maximum Conducted Transmit Power Settings

The following is a transmit power table (Japan domain) per dipole antenna in the 2.4 GHz band:

20 MHZ CHANNEL	40 MHZ CHANNEL	LEGACY DSSS RATES (1TX)	LEGACY OFDM RATES (1TX)	802.11n HT20 RATES/TURBO QAM (3TX)	802.11n HT40 RATES/TURBO QAM (3TX)
1		12.0	14.0	11.0	
2		12.0	14.0	11.0	
3	(1, 5)	12.0	14.0	11.0	11.0
4	(2, 6)	12.0	14.0	11.0	11.0
5	(3, 7)	12.0	14.0	11.0	11.0
6	(4, 8)	12.0	14.0	11.0	11.0
7	(5, 9)	12.0	14.0	11.0	11.0
8	(6, 10)	12.0	14.0	11.0	11.0
9	(7, 11)	12.0	14.0	11.0	11.0
10		12.0	14.0	11.0	11.0
11		12.0	14.0	11.0	11.0
12		12.0	14.0	11.0	
13		12.0	14.0	11.0	

Dipole antenna, peak gain = 10.5 dBi

AP7562 Japan Domain 2.4 GHz Panel Antenna Maximum Conducted Transmit Power Settings

The following is a transmit power table (Japan domain) per panel antenna in the 2.4 GHz band:

20 MHZ CHANNEL	40 MHZ CHANNEL	LEGACY DSSS RATES (1TX)	LEGACY OFDM RATES (1TX)	802.11n HT20 RATES/TURBO QAM (3TX)	802.11n HT40 RATES/TURBO QAM (3TX)
1		18.0	20.0	19.0	
2		18.0	20.0	19.0	
3	(1, 5)	18.0	20.0	19.0	19.0
4	(2, 6)	18.0	20.0	19.0	19.0
5	(3, 7)	18.0	20.0	19.0	19.0
6	(4, 8)	18.0	20.0	19.0	19.0
7	(5, 9)	18.0	20.0	19.0	19.0
8	(6, 10)	18.0	20.0	19.0	19.0
9	(7, 11)	18.0	20.0	19.0	19.0
10		18.0	20.0	19.0	19.0

20 MHZ CHANNEL	40 MHZ CHANNEL	LEGACY DSSS RATES (1TX)	LEGACY OFDM RATES (1TX)	802.11n HT20 RATES/TURBO QAM (3TX)	802.11n HT40 RATES/TURBO QAM (3TX)
11		18.0	20.0	19.0	19.0
12		18.0	20.0	19.0	
13		18.0	20.0	19.0	

Panel antenna, peak gain = 8 dBi

AP7562 Japan Domain 2.4 GHz Polarized-Panel Antenna Maximum Conducted Transmit Power Settings

The following is a transmit power table (Japan domain) per polarized panel antenna in the 2.4 GHz band:

20 MHZ CHANNEL	40 MHZ CHANNEL	LEGACY DSSS RATES (1TX)	LEGACY OFDM RATES (1TX)	802.11n HT20 RATES/TURBO QAM (3TX)	802.11n HT40 RATES/TURBO QAM (3TX)
1		16.0	20.0	17.0	
2		16.0	20.0	17.0	
3	(1, 5)	16.0	20.0	17.0	17.0
4	(2, 6)	16.0	20.0	17.0	17.0
5	(3, 7)	16.0	20.0	17.0	17.0
6	(4, 8)	16.0	20.0	17.0	17.0
7	(5, 9)	16.0	20.0	17.0	17.0
8	(6, 10)	16.0	20.0	17.0	17.0
9	(7, 11)	16.0	20.0	17.0	17.0
10		16.0	20.0	17.0	17.0
11		16.0	20.0	17.0	17.0
12		16.0	20.0	17.0	
13		16.0	20.0	17.0	

Polarized panel antenna, peak gain = 9.7 dBi

AP7562 Japan Regulatory Domain 5 GHz Band

AP7562 Japan Domain 5 GHz Dipole Antenna Model

The following is a transmit power table (Japan domain) per dipole antenna in the 5 GHz band:

20 MHZ CHANNEL	40 MHZ CHANNEL	80 MHZ CHANNELS	LEGACY OFDM RATES (1TX)	802.11n HT20 RATES (3TX)	802.11n HT40 RATES (3TX)	802.11n HT80 RATES (3TX)
36			13.0	8.0		
38	(36, 40)		13.0	8.0	8.0	
40			13.0	8.0		
42		(36, 40, 44, 48)	13.0	8.0		8.0
44			13.0	8.0		
46	(44, 48)		13.0	8.0	8.0	
48			13.0	8.0		
52			13.0	8.0		
54	(52, 56)		13.0	8.0	8.0	
56			13.0	8.0		
58		(52, 56, 60, 64)	13.0	8.0		8.0
60			13.0	8.0		
62	(60, 64)		13.0	8.0	7.5	
64			13.0	8.0		
100			20.0	15.0		
102	(100, 104)		20.0	15.0	15.0	
104			20.0	15.0		
106		(100, 104, 108, 112)	20.0	15.0		15.0
108			20.0	15.0		
110			20.0	15.0	15.0	
112			20.0	15.0		
114			20.0	15.0		
116			20.0	15.0		
118	(116, 120)		20.0	15.0	15.0	
120			20.0	15.0		
122		(116, 120, 124, 128)	20.0	15.0		15.0
124			20.0	15.0		
126	(124, 128)		20.0	15.0	14.5	
128			20.0	15.0		
130			20.0	15.0		
132			20.0	15.0		
134	(132, 136)		20.0	15.0	15.0	

20 MHZ CHANNEL	40 MHZ CHANNEL	80 MHZ CHANNELS	LEGACY OFDM RATES (1TX)	802.11n HT20 RATES (3TX)	802.11n HT40 RATES (3TX)	802.11n HT80 RATES (3TX)
136			20.0	15.0		
138			20.0	15.0		
140			20.0	15.0		
142			20.0	15.0		
144			20.0	15.0		

Dipole antenna, peak gain = 10.5 dBi

AP7562 Japan Domain 5 GHz Panel Antenna Model

The following is a transmit power table (Japan domain) per panel antenna in the 5 GHz band:

20 MHZ CHANNEL	40 MHZ CHANNEL	80 MHZ CHANNELS	LEGACY OFDM RATES (1TX)	802.11n HT20 RATES (3TX)	802.11n HT40 RATES (3TX)	802.11n HT80 RATES (3TX)
36			11.0	6.0		
38	(36, 40)		11.0	6.0	6.0	
40			11.0	6.0		
42		(36, 40, 44, 48)	11.0	6.0		6.0
44			11.0	6.0		
46	(44, 48)		11.0	6.0	6.0	
48			11.0	6.0		
52			11.0	6.0		
54	(52, 56)		11.0	6.0	6.0	
56			11.0	6.0		
58		(52, 56, 60, 64)	11.0	6.0		6.0
60			11.0	6.0		
62	(60, 64)		11.0	6.0	6.0	
64			11.0	6.0		
100			18.0	13.0		
102	(100, 104)		18.0	13.0	13.0	
104			18.0	13.0		
106		(100, 104, 108, 112)	18.0	13.0		13.0
108			18.0	13.0		
110			18.0	13.0	13.0	
112			18.0	13.0		

20 MHZ CHANNEL	40 MHZ CHANNEL	80 MHZ CHANNELS	LEGACY OFDM RATES (1TX)	802.11n HT20 RATES (3TX)	802.11n HT40 RATES (3TX)	802.11n HT80 RATES (3TX)
114			18.0	13.0		
116			18.0	13.0		
118	(116, 120)		18.0	13.0	13.0	
120			18.0	13.0		
122		(116, 120, 124, 128)	18.0	13.0		13.0
124			18.0	13.0		
126	(124, 128)		18.0	13.0	13.0	
128			18.0	13.0		
130			18.0	13.0		
132			18.0	13.0		
134	(132, 136)		18.0	13.0	13.0	
136			18.0	13.0		
138			18.0	13.0		
140			18.0	13.0		
142			18.0	13.0		
144			18.0	13.0		

Panel antenna, peak gain = 12 dBi

AP7562 Japan Domain 5 GHz Polarized-Panel Antenna Model

The following is a transmit power table (Japan domain) per polarized-panel antenna in the 5 GHz band:

20 MHZ CHANNEL	40 MHZ CHANNEL	80 MHZ CHANNELS	LEGACY OFDM RATES (1TX)	802.11n HT20 RATES (3TX)	802.11n HT40 RATES (3TX)	802.11n HT80 RATES (3TX)
36			14.0	9.0		
38	(36, 40)		14.0	9.0	9.0	
40			14.0	9.0		
42		(36, 40, 44, 48)	14.0	9.0		9.0
44			14.0	9.0		
46	(44, 48)		14.0	9.0	9.0	
48			14.0	9.0		
52			14.0	9.0		
54	(52, 56)		14.0	9.0	9.0	
56			14.0	9.0		

20 MHZ CHANNEL	40 MHZ CHANNEL	80 MHZ CHANNELS	LEGACY OFDM RATES (1TX)	802.11n HT20 RATES (3TX)	802.11n HT40 RATES (3TX)	802.11n HT80 RATES (3TX)
58		(52, 56, 60, 64)	14.0	9.0		9.0
60			14.0	9.0		
62	(60, 64)		14.0	9.0	9.0	
64			14.0	9.0		
100			20.0	16.0		
102	(100, 104)		20.0	16.0	16.0	
104			20.0	16.0		
106		(100, 104, 108, 112)	20.0	16.0		16.0
108			20.0	16.0		
110			20.0	16.0	16.0	
112			20.0	16.0		
114			20.0	16.0		
116			20.0	16.0		
118	(116, 120)		20.0	16.0	16.0	
120			20.0	16.0		
122		(116, 120, 124, 128)	20.0	16.0		16.0
124			20.0	16.0		
126	(124, 128)		20.0	16.0	16.0	
128			20.0	16.0		
130			20.0	16.0		
132			20.0	16.0		
134	(132, 136)		20.0	16.0	16.0	
136			20.0	16.0		
138			20.0	16.0		
140			20.0	16.0		
142			20.0	16.0		
144			20.0	16.0		

Polarized panel antenna, peak gain = 9.2dBi

AP7562 NCC Domain

Refer to the following for an AP7562 antenna power table for the NCC domain.

2.4 GHz 2412 to 2462 MHz

	Antenna Gain (dBi)	Type	Max Conducted Power Settings (dBm)
ML-2499-FHPA5-01R	5.3	Dipole	20
ML-2499-HPA4-01	4.5	Dipole	20
ML-2452-HPA6-01	5.3	Dipole	20
ML-2452-HPA G4A6-01	4	Dipole	20
ML-2452-HPA 6x6-036	4	Dipole	20
ML-2499-5PNL-72-N	6.5	Panel	20
ML-2452-PNL3M3-1	9.5	Dual-polarized	20
ML-2452-PNA5-01R	5.5	Panel	20

5.2 GHz 5250 to 5350 MHz

	Antenna Gain (dBi)	Type	Max Conducted Power Settings (dBm)
ML-5299-HPA5-01	5.6	Dipole	20
ML-2452-HPA6-01	6.1	Dipole	20
ML-2452-HPA G4A6-01	7.3	Dipole	20
ML-2452-HPA 6x6-036	6	Dipole	20
ML-2452-PNL3M3-1	9.2	Dual-polarized	20
ML-2452-PNA5-01R	6	Panel	20

5470 to 5725 MHz

	Antenna Gain (dBi)	Type	Max Conducted Power Settings (dBm)
ML-5299-HPA5-01	5.6	Dipole	20
ML-2452-HPA6-01	6.1	Dipole	20
ML-2452-HPA G4A6-01	7.3	Dipole	20
ML-2452-HPA 6x6-036	6	Dipole	20
ML-2452-PNL3M3-1	9.2	Dual-polarized	20
ML-2452-PNA5-01R	6	Panel	20

5725 to 5850 MHz

	Antenna Gain (dBi)	Type	Max Conducted Power Settings (dBm)
ML-5299-HPA5-01	5.6	Dipole	20
ML-2452-HPA6-01	6.1	Dipole	20
ML-2452-HPA G4A6-01	7.3	Dipole	20
ML-2452-HPA 6x6-036	6	Dipole	20
ML-2452-PNL3M3-1	9.2	Dual-polarized	20
ML-2452-PNA5-01R	6	Panel	20

26 AP8432 Regulatory Domains

AP8432 US Regulatory Domain 2.4 GHz Band
AP8432 US Regulatory Domain 5 GHz Band
AP8432 EU Regulatory Domain 2.4 GHz Band
AP8432 EU Regulatory Domain 5 GHz Band

AP8432 US Regulatory Domain 2.4 GHz Band

AP8432 US Domain 2.4 GHz Internal Antenna Maximum Conducted Transmit Power Settings

The following is a transmit power table (US domain) per internal antenna in the 2.4 GHz band:

20 MHZ CHANNEL	40 MHZ CHANNEL	LEGACY DSSS RATES (1TX)	LEGACY OFDM RATES (1TX)	802.11n HT20 RATES/TURBO QAM (3TX)	802.11n HT40 RATES/TURBO QAM (3TX)
1		21.0	18.0	16.0	
2		21.0	21.0	20.0	
3	(1, 5)	21.0	21.0	20.0	14.0
4	(2, 6)	21.0	21.0	20.0	15.0
5	(3, 7)	21.0	21.0	20.0	15.0
6	(4, 8)	21.0	21.0	20.0	15.0
7	(5, 9)	21.0	21.0	20.0	15.0
8	(6, 10)	21.0	21.0	20.0	15.0
9	(7, 11)	21.0	21.0	20.0	14.0
10		21.0	21.0	20.0	
11		21.0	17.0	16.0	

Internal antenna, peak gain = 4.4 dBi

AP8432 US Regulatory Domain 5 GHz Band

AP8432 US Domain 5 GHz Internal Antenna Model

The following is a transmit power table (US domain) per internal antenna in the 5 GHz band:

20 MHZ CHANNEL	40 MHZ CHANNEL	80 MHZ CHANNELS	LEGACY OFDM RATES (1TX)	802.11n HT20 RATES (4TX)	802.11n HT40 RATES (4TX)	802.11n HT80 RATES (4TX)
36			20.0	19.0		
38	(36, 40)		20.0	19.0	17.0	
40			20.0	19.0		
42		(36, 40, 44, 48)	20.0	19.0		17.0
44			20.0	19.0		
46	(44, 48)		20.0	19.0	19.0	
48			20.0	20.0		
52			20.0	13.0		
54	(52, 56)		20.0	13.0	17.0	
56			20.0	14.0		
58		(52, 56, 60, 64)	20.0	14.0		11.0
60			20.0	14.0		
62	(60, 64)		20.0	14.0	13.0	
64			20.0	14.0		
100			20.0	13.0		
102	(100, 104)		20.0	14.0	16.0	
104			20.0	13.0		
106		(100, 104, 108, 112)	20.0	13.0		11.0
108			20.0	13.0		
110			20.0	13.0	16.0	
112			20.0	13.0		
114			20.0	13.0		
116			20.0	13.0		
118	(116, 120)		20.0	13.0	17.0	
120			20.0	13.0		
122		(116, 120, 124, 128)	20.0	13.0		11.0
124			20.0	13.0		
126	(124, 128)		20.0	13.0	17.0	
128			20.0	13.0		
130			20.0	13.0		
132			20.0	13.0		
134	(132, 136)		20.0	13.0	17.0	

20 MHZ CHANNEL	40 MHZ CHANNEL	80 MHZ CHANNELS	LEGACY OFDM RATES (1TX)	802.11n HT20 RATES (4TX)	802.11n HT40 RATES (4TX)	802.11n HT80 RATES (4TX)
136			20.0	13.0		
138			20.0	13.0		
140			19.0	13.0		
142			19.0	13.0	17.0	
144			19.0	5.0		
149			20.0	16.0		
151	(149, 153)		20.0	20.0	14.0	
153			20.0	20.0		
155		(149, 153, 157, 161)	20.0	20.0		12.0
157			20.0	20.0		
159	(157, 161)		20.0	20.0	16.0	
161			20.0	20.0		
165			18.0	18.0		

Internal antenna, peak gain = 6.8 dBi

AP8432 EU Regulatory Domain 2.4 GHz Band

AP8432 EU Domain 2.4 GHz Internal Antenna Maximum Conducted Transmit Power Settings

The following is a transmit power table (EU domain) per internal antenna in the 2.4 GHz band:

20 MHZ CHANNEL	40 MHZ CHANNEL	LEGACY DSSS RATES (1TX)	LEGACY OFDM RATES (1TX)	802.11n HT20 RATES/TURBO QAM (3TX)	802.11n HT40 RATES/TURBO QAM (3TX)
1		15.5	15.5	10.5	
2		15.5	15.5	10.5	
3	(1, 5)	15.5	15.5	10.5	10.5
4	(2, 6)	15.5	15.5	10.5	10.5
5	(3, 7)	15.5	15.5	10.5	10.5
6	(4, 8)	15.5	15.5	10.5	10.5
7	(5, 9)	15.5	15.5	10.5	10.5
8	(6, 10)	15.5	15.5	10.5	10.5
9	(7, 11)	15.5	15.5	10.5	10.5
10		15.5	15.5	10.5	10.5
11		15.5	15.5	10.5	10.5

20 MHZ CHANNEL	40 MHZ CHANNEL	LEGACY DSSS RATES (1TX)	LEGACY OFDM RATES (1TX)	802.11n HT20 RATES/TURBO QAM (3TX)	802.11n HT40 RATES/TURBO QAM (3TX)
12		15.5	15.5	10.5	
13		15.5	15.5	10.5	

Dipole antenna, peak gain = 4.4 dBi

AP8432 EU Regulatory Domain 5 GHz Band

AP8432 EU Domain 5 GHz Internal Antenna Model

The following is a transmit power table (EU domain) per internal antenna in the 5 GHz band:

20 MHZ CHANNEL	40 MHZ CHANNEL	80 MHZ CHANNELS	LEGACY OFDM RATES (1TX)	802.11n HT20 RATES (4TX)	802.11n HT40 RATES (4TX)	802.11n HT80 RATES (4TX)
36			16.0	10.0		
38	(36, 40)		16.0	10.0	10.0	
40			16.0	10.0		
42		(36, 40, 44, 48)	16.0	10.0		10.0
44			16.0	10.0		
46	(44, 48)		16.0	10.0	10.0	
48			16.0	10.0		
52			16.0	10.0		
54	(52, 56)		16.0	10.0	10.0	
56			16.0	10.0		
58		(52, 56, 60, 64)	16.0	10.0		10.0
60			16.0	10.0		
62	(60, 64)		16.0	10.0	10.0	
64			16.0	10.0		
100			20.0	17.0		
102	(100, 104)		20.0	17.0	17.0	
104			20.0	17.0		
106		(100, 104, 108, 112)	20.0	17.0		17.0
108			20.0	17.0		
110			20.0	17.0	17.0	
112			20.0	17.0		

20 MHZ CHANNEL	40 MHZ CHANNEL	80 MHZ CHANNELS	LEGACY OFDM RATES (1TX)	802.11n HT20 RATES (4TX)	802.11n HT40 RATES (4TX)	802.11n HT80 RATES (4TX)
114			20.0	17.0		
116			20.0	17.0		
118	(116, 120)		20.0	17.0	17.0	
120			20.0	17.0		
122		(116, 120, 124, 128)	20.0	17.0		17.0
124			20.0	17.0		
126	(124, 128)		20.0	17.0	17.0	
128			20.0	17.0		
130			20.0	17.0		
132			20.0	17.0		
134	(132, 136)		20.0	17.0	17.0	
136			20.0	17.0		
138			20.0	17.0		17.0
140			20.0	17.0		
142			20.0	17.0	17.0	
144			20.0	17.0		

Dipole antenna, peak gain = 6.8 dBi

27 AP8533 Regulatory Domains

AP8533 US Regulatory Domain 2.4 GHz Band
 AP8533 US Regulatory Domain 5 GHz Band
 EU Regulatory Domain 2.4 GHz Band
 AP8533 EU Regulatory Domain 5 GHz Band

AP8533 US Regulatory Domain 2.4 GHz Band

AP8533 US Domain 2.4 GHz Internal Antenna Maximum Conducted Transmit Power Settings

The following is a transmit power table (US domain) per internal antenna in the 2.4 GHz band:

20 MHZ CHANNEL	40 MHZ CHANNEL	LEGACY DSSS RATES (1TX)	LEGACY OFDM RATES (1TX)	802.11n HT20 RATES/TURBO QAM (4TX)	802.11n HT40 RATES/TURBO QAM (4TX)
1		21.0	16.0	16.0	
2		21.0	20.0	19.0	
3	(1, 5)	21.0	20.0	19.0	14.0
4	(2, 6)	21.0	20.0	19.0	14.0
5	(3, 7)	21.0	20.0	19.0	14.0
6	(4, 8)	21.0	20.0	19.0	14.0
7	(5, 9)	21.0	20.0	19.0	14.0
8	(6, 10)	21.0	20.0	19.0	14.0
9	(7, 11)	21.0	20.0	19.0	13.0
10		21.0	20.0	19.0	
11		21.0	17.0	16.0	

Internal antenna, peak gain = 5.2 dBi

AP8533 US Domain 2.4 GHz Dipole Antenna Maximum Conducted Transmit Power Settings

The following is a transmit power table (US domain) per internal antenna in the 2.4 GHz band:

20 MHZ CHANNEL	40 MHZ CHANNEL	LEGACY DSSS RATES (1TX)	LEGACY OFDM RATES (1TX)	802.11n HT20 RATES/TURBO QAM (4TX)	802.11n HT40 RATES/TURBO QAM (4TX)
1		21.0	17.0	15.0	
2		21.0	20.0	19.0	
3	(1, 5)	21.0	20.0	19.0	14.0
4	(2, 6)	21.0	20.0	19.0	14.0
5	(3, 7)	21.0	20.0	19.0	14.0
6	(4, 8)	21.0	20.0	19.0	14.0
7	(5, 9)	21.0	20.0	19.0	14.0
8	(6, 10)	21.0	20.0	19.0	14.0
9	(7, 11)	21.0	20.0	19.0	13.0
10		21.0	20.0	19.0	
11		21.0	17.0	14.0	

Dipole antenna, peak gain = 5.3 dBi

AP8533 US Domain 2.4 GHz Panel Antenna Maximum Conducted Transmit Power Settings

The following is a transmit power table (US domain) per panel antenna in the 2.4 GHz band:

20 MHZ CHANNEL	40 MHZ CHANNEL	LEGACY DSSS RATES (1TX)	LEGACY OFDM RATES (1TX)	802.11n HT20 RATES/TURBO QAM (4TX)	802.11n HT40 RATES/TURBO QAM (4TX)
1		21.0	16.0	15.0	
2		21.0	20.0	19.0	
3	(1, 5)	21.0	20.0	19.0	13.0
4	(2, 6)	21.0	20.0	19.0	13.0
5	(3, 7)	21.0	20.0	19.0	13.0
6	(4, 8)	21.0	20.0	19.0	13.0
7	(5, 9)	21.0	20.0	19.0	13.0
8	(6, 10)	21.0	20.0	19.0	13.0
9	(7, 11)	21.0	20.0	19.0	12.0
10		21.0	20.0	19.0	
11		21.0	17.0	15.0	

Panel antenna, peak gain = 5.5 dBi

AP8533 US Domain 2.4 GHz Polarized-Panel Antenna Maximum Conducted Transmit Power Settings

The following is a transmit power table (US domain) per polarized-panel antenna in the 2.4 GHz band:

20 MHZ CHANNEL	40 MHZ CHANNEL	LEGACY DSSS RATES (1TX)	LEGACY OFDM RATES (1TX)	802.11n HT20 RATES/TURBO QAM (4TX)	802.11n HT40 RATES/TURBO QAM (4TX)
1		21.0	18.0	16.0	
2		21.0	20.0	19.0	
3	(1, 5)	21.0	20.0	19.0	14.0
4	(2, 6)	21.0	20.0	19.0	14.0
5	(3, 7)	21.0	20.0	19.0	14.0
6	(4, 8)	21.0	20.0	19.0	14.0
7	(5, 9)	21.0	20.0	19.0	14.0
8	(6, 10)	21.0	20.0	19.0	14.0
9	(7, 11)	21.0	20.0	19.0	13.0
10		21.0	20.0	19.0	
11		21.0	18.0	16.0	

Polarized-panel antenna, peak gain = 6.92 dBi

AP8533 External Bluetooth Antenna Options

The maximum transmit power for the Bluetooth radio is 6dBm. The antenna gain information is as follows:

Internal Antenna Gain (dBi)	External Antenna Gain (dBi)
7.7	Any 2.4GHz antenna in the Zebra portfolio, up to 11dBi, is compatible with this radio

AP8533 US Regulatory Domain 5 GHz Band

AP8533 US Domain 5 GHz Internal Antenna Model

The following is a transmit power table (US domain) per internal antenna in the 5 GHz band:

20 MHZ CHANNEL	40 MHZ CHANNEL	80 MHZ CHANNELS	LEGACY OFDM RATES (1TX)	802.11n HT20 RATES (4TX)	802.11n HT40 RATES (4TX)	802.11n HT80 RATES (4TX)
36			20.0	19.0		
38	(36, 40)		20.0	19.0	17.0	
40			20.0	19.0		

20 MHZ CHANNEL	40 MHZ CHANNEL	80 MHZ CHANNELS	LEGACY OFDM RATES (1TX)	802.11n HT20 RATES (4TX)	802.11n HT40 RATES (4TX)	802.11n HT80 RATES (4TX)
42		(36, 40, 44, 48)	20.0	19.0		17.0
44			20.0	19.0		
46	(44, 48)		20.0	19.0	19.0	
48			20.0	20.0		
52			20.0	13.0		
54	(52, 56)		20.0	13.0	17.0	
56			20.0	14.0		
58		(52, 56, 60, 64)	20.0	14.0		11.0
60			20.0	14.0		
62	(60, 64)		20.0	14.0	13.0	
64			20.0	14.0		
100			20.0	13.0		
102	(100, 104)		20.0	14.0	16.0	
104			20.0	13.0		
106		(100, 104, 108, 112)	20.0	13.0		11.0
108			20.0	13.0		
110			20.0	13.0	16.0	
112			20.0	13.0		
114			20.0	13.0		
116			20.0	13.0		
118	(116, 120)		20.0	13.0	17.0	
120			20.0	13.0		
122		(116, 120, 124, 128)	20.0	13.0		11.0
124			20.0	13.0		
126	(124, 128)		20.0	13.0	17.0	
128			20.0	13.0		
130			20.0	13.0		
132			20.0	13.0		
134	(132, 136)		20.0	13.0	17.0	
136			20.0	13.0		
138			20.0	13.0		
140			19.0	13.0		

20 MHZ CHANNEL	40 MHZ CHANNEL	80 MHZ CHANNELS	LEGACY OFDM RATES (1TX)	802.11n HT20 RATES (4TX)	802.11n HT40 RATES (4TX)	802.11n HT80 RATES (4TX)
142			19.0	13.0	17.0	
144			19.0	5.0		
149			20.0	16.0		
151	(149, 153)		20.0	20.0	14.0	
153			20.0	20.0		
155		(149, 153, 157, 161)	20.0	20.0		12.0
157			20.0	20.0		
159	(157, 161)		20.0	20.0	16.0	
161			20.0	20.0		
165			20.0	18.0		

Internal antenna, peak gain = 6.8 dBi

AP8533 US Domain 5 GHz Dipole Antenna Model

The following is a transmit power table (US domain) per dipole antenna in the 5 GHz band:

20 MHZ CHANNEL	40 MHZ CHANNEL	80 MHZ CHANNELS	LEGACY OFDM RATES (1TX)	802.11n HT20 RATES (4TX)	802.11n HT40 RATES (4TX)	802.11n HT80 RATES (4TX)
36			20.0	19.0		
38	(36, 40)		20.0	19.0	19.0	
40			20.0	19.0		
42		(36, 40, 44, 48)	20.0	19.0		17.0
44			20.0	19.0		
46	(44, 48)		20.0	19.0	19.0	
48			20.0	19.0		
52			20.0	15.0		
54	(52, 56)		20.0	15.0	18.0	
56			20.0	15.0		
58		(52, 56, 60, 64)	20.0	15.0		13.0
60			20.0	15.0		
62	(60, 64)		20.0	15.0	14.0	
64			20.0	16.0		
100			20.0	15.0		
102	(100, 104)		20.0	15.0	17.0	

20 MHZ CHANNEL	40 MHZ CHANNEL	80 MHZ CHANNELS	LEGACY OFDM RATES (1TX)	802.11n HT20 RATES (4TX)	802.11n HT40 RATES (4TX)	802.11n HT80 RATES (4TX)
104			20.0	15.0		
106		(100, 104, 108, 112)	20.0	15.0		14.0
108			20.0	15.0		
110			20.0	15.0	17.0	
112			20.0	15.0		
114			20.0	15.0		
116			20.0	15.0		
118	(116, 120)		20.0	15.0	17.0	
120			20.0	15.0		
122		(116, 120, 124, 128)	20.0	15.0		14.0
124			20.0	15.0		
126	(124, 128)		20.0	15.0	17.0	
128			20.0	15.0		
130			20.0	15.0		
132			20.0	15.0		
134	(132, 136)		20.0	15.0	17.0	
136			20.0	15.0		
138			20.0	15.0		
140			20.0	15.0		
142			20.0	15.0	17.0	
144			20.0	15.0		
149			20.0	18.0		
151	(149, 153)		20.0	20.0	14.0	
153			20.0	20.0		
155		(149, 153, 157, 161)	20.0	20.0		14.0
157			20.0	20.0		
159	(157, 161)		20.0	20.0	18.0	
161			20.0	20.0		
165			20.0	20.0		

Dipole antenna, peak gain = 7.3 dBi

AP8533 US Domain 5 GHz Panel Antenna Model

The following is a transmit power table (US domain) per panel antenna in the 5 GHz band:

20 MHZ CHANNEL	40 MHZ CHANNEL	80 MHZ CHANNELS	LEGACY OFDM RATES (1TX)	802.11n HT20 RATES (4TX)	802.11n HT40 RATES (4TX)	802.11n HT80 RATES (4TX)
36			20.0	19.0		
38	(36, 40)		20.0	19.0	19.0	
40			20.0	19.0		
42		(36, 40, 44, 48)	20.0	19.0		18.0
44			20.0	19.0		
46	(44, 48)		20.0	19.0	19.0	
48			20.0	20.0		
52			20.0	15.0		
54	(52, 56)		20.0	15.0	19.0	
56			20.0	16.0		
58		(52, 56, 60, 64)	20.0	16.0		12.0
60			20.0	16.0		
62	(60, 64)		20.0	16.0	13.0	
64			20.0	16.0		
100			20.0	15.0		
102	(100, 104)		20.0	16.0	18.0	
104			20.0	15.0		
106		(100, 104, 108, 112)	20.0	15.0		10.0
108			20.0	15.0		
110			20.0	15.0	18.0	
112			20.0	15.0		
114			20.0	15.0		
116			20.0	15.0		
118	(116, 120)		20.0	15.0	18.0	
120			20.0	15.0		
122		(116, 120, 124, 128)	20.0	15.0		10.0
124			20.0	15.0		
126	(124, 128)		20.0	15.0	18.0	
128			20.0	15.0		
130			20.0	15.0		

20 MHZ CHANNEL	40 MHZ CHANNEL	80 MHZ CHANNELS	LEGACY OFDM RATES (ITX)	802.11n HT20 RATES (4TX)	802.11n HT40 RATES (4TX)	802.11n HT80 RATES (4TX)
132			20.0	15.0		
134	(132, 136)		20.0	15.0	18.0	
136			20.0	15.0		
138			20.0	15.0		
140			20.0	15.0		
142			20.0	15.0	18.0	
144			20.0	15.0		
149			20.0	18.0		
151	(149, 153)		20.0	20.0	15.0	
153			20.0	20.0		
155		(149, 153, 157, 161)	20.0	20.0		15.0
157			20.0	20.0		
159	(157, 161)		20.0	20.0	18.0	
161			20.0	20.0		
165			20.0	19.0		

Panel antenna, peak gain = 6 dBi

AP8533 US Domain 5 GHz Polarized-Panel Antenna Model

The following is a transmit power table (US domain) per polarized-panel antenna in the 5 GHz band:

20 MHZ CHANNEL	40 MHZ CHANNEL	80 MHZ CHANNELS	LEGACY OFDM RATES (ITX)	802.11n HT20 RATES (4TX)	802.11n HT40 RATES (4TX)	802.11n HT80 RATES (4TX)
36			20.0	19.0		
38	(36, 40)		20.0	19.0	19.0	
40			20.0	19.0		
42		(36, 40, 44, 48)	20.0	19.0		17.0
44			20.0	19.0		
46	(44, 48)		20.0	19.0	19.0	
48			20.0	20.0		
52			20.0	19.0		
54	(52, 56)		20.0	19.0	20.0	
56			20.0	20.0		
58		(52, 56, 60, 64)	20.0	20.0		15.0

20 MHZ CHANNEL	40 MHZ CHANNEL	80 MHZ CHANNELS	LEGACY OFDM RATES (1TX)	802.11n HT20 RATES (4TX)	802.11n HT40 RATES (4TX)	802.11n HT80 RATES (4TX)
60			20.0	20.0		
62	(60, 64)		20.0	20.0	16.0	
64			20.0	19.0		
100			20.0	20.0		
102	(100, 104)		20.0	20.0	17.0	
104			20.0	20.0		
106		(100, 104, 108, 112)	20.0	20.0		15.0
108			20.0	20.0		
110			20.0	20.0	19.0	
112			20.0	20.0		
114			20.0	20.0		
116			20.0	20.0		
118	(116, 120)		20.0	20.0	19.0	
120			20.0	20.0		
122		(116, 120, 124, 128)	20.0	20.0		15.0
124			20.0	20.0		
126	(124, 128)		20.0	20.0	19.0	
128			20.0	20.0		
130			20.0	20.0		
132			20.0	20.0		
134	(132, 136)		20.0	20.0	19.0	
136			20.0	20.0		
138			20.0	20.0		
140			20.0	19.0		
142			20.0	19.0	19.0	
144			20.0	19.0		
149			20.0	19.0		
151	(149, 153)		20.0	20.0	14.0	
153			20.0	20.0		
155		(149, 153, 157, 161)	20.0	20.0		14.0
157			20.0	20.0		
159	(157, 161)		20.0	20.0	18.0	

20 MHZ CHANNEL	40 MHZ CHANNEL	80 MHZ CHANNELS	LEGACY OFDM RATES (1TX)	802.11n HT20 RATES (4TX)	802.11n HT40 RATES (4TX)	802.11n HT80 RATES (4TX)
161			20.0	20.0		
165			20.0	20.0		

Polarized-panel antenna, peak gain = 7.23 dBi

EU Regulatory Domain 2.4 GHz Band

AP8533 EU Domain 2.4 GHz Internal Antenna Maximum Conducted Transmit Power Settings

The following is a transmit power table (EU domain) per internal antenna in the 2.4 GHz band:

20 MHZ CHANNEL	40 MHZ CHANNEL	LEGACY DSSS RATES (1TX)	LEGACY OFDM RATES (1TX)	802.11n HT20 RATES/TURBO QAM (4TX)	802.11n HT40 RATES/TURBO QAM (4TX)
1		15.0	15.0	9.0	
2		15.0	15.0	9.0	
3	(1, 5)	15.0	15.0	9.0	9.0
4	(2, 6)	15.0	15.0	9.0	9.0
5	(3, 7)	15.0	15.0	9.0	9.0
6	(4, 8)	15.0	15.0	9.0	9.0
7	(5, 9)	15.0	15.0	9.0	9.0
8	(6, 10)	15.0	15.0	9.0	9.0
9	(7, 11)	15.0	15.0	9.0	9.0
10		15.0	15.0	9.0	9.0
11		15.0	15.0	9.0	9.0
12		15.0	15.0	9.0	
13		15.0	15.0	9.0	

Internal antenna, peak gain = 5.2 dBi

AP8533 EU Domain 2.4 GHz Dipole Antenna Maximum Conducted Transmit Power Settings

The following is a transmit power table (EU domain) per dipole antenna in the 2.4 GHz band:

20 MHZ CHANNEL	40 MHZ CHANNEL	LEGACY DSSS RATES (1TX)	LEGACY OFDM RATES (1TX)	802.11n HT20 RATES/TURBO QAM (4TX)	802.11n HT40 RATES/TURBO QAM (4TX)
1		16.0	16.0	10.0	
2		16.0	16.0	10.0	
3	(1, 5)	16.0	16.0	10.0	10.0
4	(2, 6)	16.0	16.0	10.0	10.0
5	(3, 7)	16.0	16.0	10.0	10.0
6	(4, 8)	16.0	16.0	10.0	10.0
7	(5, 9)	16.0	16.0	10.0	10.0
8	(6, 10)	16.0	16.0	10.0	10.0
9	(7, 11)	16.0	16.0	10.0	10.0
10		16.0	16.0	10.0	10.0
11		16.0	16.0	10.0	10.0
12		16.0	16.0	10.0	
13		16.0	16.0	10.0	

Dipole antenna, peak gain = 5.3 dBi

AP8533 EU Domain 2.4 GHz Panel or Polarized-Panel Maximum Conducted Transmit Power Settings

The following is a transmit power table (EU domain) per panel or polarized-panel antenna in the 2.4 GHz band:

20 MHZ CHANNEL	40 MHZ CHANNEL	LEGACY DSSS RATES (1TX)	LEGACY OFDM RATES (1TX)	802.11n HT20 RATES/TURBO QAM (4TX)	802.11n HT40 RATES/TURBO QAM (4TX)
1		15.0	15.0	9.0	
2		15.0	15.0	9.0	
3	(1, 5)	15.0	15.0	9.0	9.0
4	(2, 6)	15.0	15.0	9.0	9.0
5	(3, 7)	15.0	15.0	9.0	9.0
6	(4, 8)	15.0	15.0	9.0	9.0
7	(5, 9)	15.0	15.0	9.0	9.0
8	(6, 10)	15.0	15.0	9.0	9.0
9	(7, 11)	15.0	15.0	9.0	9.0
10		15.0	15.0	9.0	9.0
11		15.0	15.0	9.0	9.0

20 MHZ CHANNEL	40 MHZ CHANNEL	LEGACY DSSS RATES (1TX)	LEGACY OFDM RATES (1TX)	802.11n HT20 RATES/TURBO QAM (4TX)	802.11n HT40 RATES/TURBO QAM (4TX)
12		15.0	15.0	9.0	
13		15.0	15.0	9.0	

Panel or polarized-panel antenna, peak gain = 6 dBi

AP8533 EU Domain 2.4 GHz Patch Antenna Maximum Conducted Transmit Power Settings

The following is a transmit power table (EU domain) per patch antenna in the 2.4 GHz band:

20 MHZ CHANNEL	40 MHZ CHANNEL	LEGACY DSSS RATES (1TX)	LEGACY OFDM RATES (1TX)	802.11n HT20 RATES/TURBO QAM (4TX)	802.11n HT40 RATES/TURBO QAM (4TX)
1		15.0	15.0	9.0	
2		15.0	15.0	9.0	
3	(1, 5)	15.0	15.0	9.0	9.0
4	(2, 6)	15.0	15.0	9.0	9.0
5	(3, 7)	15.0	15.0	9.0	9.0
6	(4, 8)	15.0	15.0	9.0	9.0
7	(5, 9)	15.0	15.0	9.0	9.0
8	(6, 10)	15.0	15.0	9.0	9.0
9	(7, 11)	15.0	15.0	9.0	9.0
10		15.0	15.0	9.0	9.0
11		15.0	15.0	9.0	9.0
12		15.0	15.0	9.0	
13		15.0	15.0	9.0	

Patch antenna, peak gain = 5.9 dBi

AP8533 EU Domain 2.4 GHz External Bluetooth Antenna Options

The maximum transmit power for the Bluetooth radio is 6dBm. The antenna gain information is as follows:

Internal Antenna Gain (dBi)	External Antenna Gain (dBi)
7.7	Any 2.4GHz antenna in the Zebra portfolio, up to 11dBi, is compatible with this radio

AP8533 EU Regulatory Domain 5 GHz Band

AP8533 EU Domain 5 GHz Internal Antenna Model

The following is a transmit power table (EU domain) per internal antenna in the 5 GHz band:

20 MHZ CHANNEL	40 MHZ CHANNEL	80 MHZ CHANNELS	LEGACY OFDM RATES (1TX)	802.11n HT20 RATES (4TX)	802.11n HT40 RATES (4TX)	802.11n HT80 RATES (4TX)
36			16.0	10.0		
38	(36, 40)		16.0	10.0	10.0	
40			16.0	10.0		
42		(36, 40, 44, 48)	16.0	10.0		10.0
44			16.0	10.0		
46	(44, 48)		16.0	10.0	10.0	
48			16.0	10.0		
52			16.0	10.0		
54	(52, 56)		16.0	10.0	10.0	
56			16.0	10.0		
58		(52, 56, 60, 64)	16.0	10.0		10.0
60			16.0	10.0		
62	(60, 64)		16.0	10.0	10.0	
64			16.0	10.0		
100			20.0	17.0		
102	(100, 104)		20.0	17.0	17.0	
104			20.0	17.0		
106		(100, 104, 108, 112)	20.0	17.0		17.0
108			20.0	17.0		
110			20.0	17.0	17.0	
112			20.0	17.0		
114			20.0	17.0		
116			20.0	17.0		
118	(116, 120)		20.0	17.0	17.0	
120			20.0	17.0		
122		(116, 120, 124, 128)	20.0	17.0		17.0
124			20.0	17.0		

20 MHZ CHANNEL	40 MHZ CHANNEL	80 MHZ CHANNELS	LEGACY OFDM RATES (1TX)	802.11n HT20 RATES (4TX)	802.11n HT40 RATES (4TX)	802.11n HT80 RATES (4TX)
126	(124, 128)		20.0	17.0	17.0	
128			20.0	17.0		
130			20.0	17.0		
132			20.0	17.0		
134	(132, 136)		20.0	17.0	17.0	
136			20.0	17.0		
138			20.0	17.0		
140			20.0	17.0		
142			20.0	17.0	17.0	
144			20.0	17.0		

Internal antenna, peak gain = 6.8 dBi

AP8533 EU Domain 5 GHz Dipole Antenna Model

The following is a transmit power table (EU domain) per dipole antenna in the 5 GHz band:

20 MHZ CHANNEL	40 MHZ CHANNEL	80 MHZ CHANNELS	LEGACY OFDM RATES (1TX)	802.11n HT20 RATES (4TX)	802.11n HT40 RATES (4TX)	802.11n HT80 RATES (4TX)
36			18.0	12.0		
38	(36, 40)		18.0	12.0	12.0	
40			18.0	12.0		
42		(36, 40, 44, 48)	18.0	12.0		12.0
44			18.0	12.0		
46	(44, 48)		18.0	12.0	12.0	
48			18.0	12.0		
52			18.0	12.0		
54	(52, 56)		18.0	12.0	12.0	
56			18.0	12.0		
58		(52, 56, 60, 64)	18.0	12.0		12.0
60			18.0	12.0		
62	(60, 64)		18.0	12.0	12.0	
64			18.0	12.0		
100			20.0	19.0		
102	(100, 104)		20.0	19.0	19.0	

20 MHZ CHANNEL	40 MHZ CHANNEL	80 MHZ CHANNELS	LEGACY OFDM RATES (1TX)	802.11n HT20 RATES (4TX)	802.11n HT40 RATES (4TX)	802.11n HT80 RATES (4TX)
104			20.0	19.0		
106		(100, 104, 108, 112)	20.0	19.0		19.0
108			20.0	19.0		
110			20.0	19.0	19.0	
112			20.0	19.0		
114			20.0	19.0		
116			20.0	19.0		
118	(116, 120)		20.0	19.0	19.0	
120			20.0	19.0		
122		(116, 120, 124, 128)	20.0	19.0		19.0
124			20.0	19.0		
126	(124, 128)		20.0	19.0	19.0	
128			20.0	19.0		
130			20.0	19.0		
132			20.0	19.0		
134	(132, 136)		20.0	19.0	19.0	
136			20.0	19.0		
138			20.0	19.0		
140			20.0	19.0		
142			20.0	19.0	19.0	
144			20.0	19.0		

Dipole antenna, peak gain = 8 dBi

AP8533 EU Domain 5 GHz Panel or Polarized-Panel Antenna Model

The following is a transmit power table (EU domain) per panel or polarized-panel antenna in the 5 GHz band:

20 MHZ CHANNEL	40 MHZ CHANNEL	80 MHZ CHANNELS	LEGACY OFDM RATES (1TX)	802.11n HT20 RATES (4TX)	802.11n HT40 RATES (4TX)	802.11n HT80 RATES (4TX)
36			16.0	10.0		
38	(36, 40)		16.0	10.0	10.0	
40			16.0	10.0		
42		(36, 40, 44, 48)	16.0	10.0		10.0

20 MHZ CHANNEL	40 MHZ CHANNEL	80 MHZ CHANNELS	LEGACY OFDM RATES (1TX)	802.11n HT20 RATES (4TX)	802.11n HT40 RATES (4TX)	802.11n HT80 RATES (4TX)
44			16.0	10.0		
46	(44, 48)		16.0	10.0	10.0	
48			16.0	10.0		
52			16.0	10.0		
54	(52, 56)		16.0	10.0	10.0	
56			16.0	10.0		
58		(52, 56, 60, 64)	16.0	10.0		10.0
60			16.0	10.0		
62	(60, 64)		16.0	10.0	10.0	
64			16.0	10.0		
100			20.0	17.0		
102	(100, 104)		20.0	17.0	17.0	
104			20.0	17.0		
106		(100, 104, 108, 112)	20.0	17.0		17.0
108			20.0	17.0		
110			20.0	17.0	17.0	
112			20.0	17.0		
114			20.0	17.0		
116			20.0	17.0		
118	(116, 120)		20.0	17.0	17.0	
120			20.0	17.0		
122		(116, 120, 124, 128)	20.0	17.0		17.0
124			20.0	17.0		
126	(124, 128)		20.0	17.0	17.0	
128			20.0	17.0		
130			20.0	17.0		
132			20.0	17.0		
134	(132, 136)		20.0	17.0	17.0	
136			20.0	17.0		
138			20.0	17.0		
140			20.0	17.0		
142			20.0	17.0	17.0	
144			20.0	17.0		

Panel or polarized panel-antenna, peak gain = 10 dBi

AP8533 EU Domain 5 GHz Patch Antenna Model

The following is a transmit power table (EU domain) per patch antenna in the 5 GHz band:

20 MHZ CHANNEL	40 MHZ CHANNEL	80 MHZ CHANNELS	LEGACY OFDM RATES (1TX)	802.11n HT20 RATES (4TX)	802.11n HT40 RATES (4TX)	802.11n HT80 RATES (4TX)
36			17.0	11.0		
38	(36, 40)		17.0	11.0	11.0	
40			17.0	11.0		
42		(36, 40, 44, 48)	17.0	11.0		11.0
44			17.0	11.0		
46	(44, 48)		17.0	11.0	11.0	
48			17.0	11.0		
52			17.0	11.0		
54	(52, 56)		17.0	11.0	11.0	
56			17.0	11.0		
58		(52, 56, 60, 64)	17.0	11.0		11.0
60			17.0	11.0		
62	(60, 64)		17.0	11.0	11.0	
64			17.0	11.0		
100			20.0	18.0		
102	(100, 104)		20.0	18.0	18.0	
104			20.0	18.0		
106		(100, 104, 108, 112)	20.0	18.0		18.0
108			20.0	18.0		
110			20.0	18.0	18.0	
112			20.0	18.0		
114			20.0	18.0		
116			20.0	18.0		
118	(116, 120)		20.0	18.0	18.0	
120			20.0	18.0		
122		(116, 120, 124, 128)	20.0	18.0		18.0
124			20.0	18.0		
126	(124, 128)		20.0	18.0	18.0	

20 MHZ CHANNEL	40 MHZ CHANNEL	80 MHZ CHANNELS	LEGACY OFDM RATES (1TX)	802.11n HT20 RATES (4TX)	802.11n HT40 RATES (4TX)	802.11n HT80 RATES (4TX)
128			20.0	18.0		
130			20.0	18.0		
132			20.0	18.0		
134	(132, 136)		20.0	18.0	18.0	
136			20.0	18.0		
138			20.0	18.0		
140			20.0	18.0		
142			20.0	18.0	18.0	
144			20.0	18.0		

Patch antenna, peak gain = 9.2 dBi

Glossary

ad hoc mode

An 802.11 networking framework in which devices or stations communicate directly with each other, without the use of an AP.

ARP

Address Resolution Protocol is part of the TCP/IP suite used to dynamically associate a device's physical address (MAC address) with its logical address (IP address). The system broadcasts an ARP request, containing the IP address, and the device with that IP address sends back its MAC address so that traffic can be transmitted.

ATM

Asynchronous Transmission Mode is a start/stop transmission in which each character is preceded by a start signal and followed by one or more stop signals. A variable time interval can exist between characters. ATM is the preferred technology for the transfer of images.

BSS

Basic Service Set is a wireless topology consisting of one access point connected to a wired network and a set of wireless devices. Also called an infrastructure network. See also *IBSS (Independent Basic Service Set)*.

Chalet

Chalet is a web-based user interface for setting up and viewing information about a switch, removing the need to enter common commands individually in the CLI.

CHAP

Challenge-Handshake Authentication Protocol is one of the two main authentication protocols used to verify a user's name and password for PPP Internet connections. CHAP is more secure because it performs a three-way handshake during the initial link establishment between the home and remote machines. It can also repeat the authentication anytime after the link has been established.

CLI

Command Line Interface. The CLI provides an environment to issue commands to monitor and manage switches and wireless appliances.

Data Center Connect

DCC, formerly known as DCM (Data Center Manager), is a data center fabric management and automation tool that improves the efficiency of managing a large virtual and physical network. DCC provides an integrated view of the server, storage, and networking operations, removing the need to use multiple tools and management systems. DCC automates VM assignment, allocates appropriate network resources, and applies individual policies to various data objects in the switching fabric (reducing VM sprawl). Learn more about DCC at <http://www.extremenetworks.com/product/data-center-connect/>.

DoS attack

Denial of Service attacks occur when a critical network or computing resource is overwhelmed so that legitimate requests for service cannot succeed. In its simplest form, a DoS attack is indistinguishable

from normal heavy traffic. ExtremeXOS software has configurable parameters that allow you to defeat DoS attacks.

DSSS

Direct-Sequence Spread Spectrum is a transmission technology used in Local Area Wireless Network (LAWN) transmissions where a data signal at the sending station is combined with a higher data rate bit sequence, or chipping code, that divides the user data according to a spreading ratio. The chipping code is a redundant bit pattern for each bit that is transmitted, which increases the signal's resistance to interference. If one or more bits in the pattern are damaged during transmission, the original data can be recovered due to the redundancy of the transmission. (Compare with [*FHSS \(Frequency-Hopping Spread Spectrum\)*](#).)

EAP-TLS/EAP-TTLS

EAP-TLS Extensible Authentication Protocol - Transport Layer Security. A general protocol for authentication that also supports multiple authentication methods, such as token cards, Kerberos, one-time passwords, certificates, public key authentication and smart cards.

IEEE 802.1x specifies how EAP should be encapsulated in LAN frames.

In wireless communications using EAP, a user requests connection to a WLAN through an access point, which then requests the identity of the user and transmits that identity to an authentication server such as RADIUS. The server asks the access point for proof of identity, which the access point gets from the user and then sends back to the server to complete the authentication.

EAP-TLS provides for certificate-based and mutual authentication of the client and the network. It relies on client-side and server-side certificates to perform authentication and can be used to dynamically generate user-based and session-based WEP keys.

EAP-TTLS (Tunneled Transport Layer Security) is an extension of EAP-TLS to provide certificate-based, mutual authentication of the client and network through an encrypted tunnel, as well as to generate dynamic, per-user, per-session WEP keys. Unlike EAP-TLS, EAP-TTLS requires only server-side certificates.

(See also [*PEAP \(Protected Extensible Authentication Protocol\)*](#).)

ESRP

Extreme Standby Router Protocol is an Extreme Networks-proprietary protocol that provides redundant Layer 2 and routing services to users.

Extreme Access Control

EAC, formerly NAC™, featuring both physical and virtual appliances, is a pre- and post-connect solution for wired and wireless LAN and VPN users. Using Identity and Access appliances and/or Identity and Access Virtual Appliance with the [*XMC \(Extreme Management Center\)*](#) software, you can ensure only the right users have access to the right information from the right place at the right time. EAC is tightly integrated with the Intrusion Prevention System (IPS) and Security Information and Event Manager (SIEM) to deliver best-in-class post-connect access control. Learn more about EAC at <http://www.extremenetworks.com/product/extreme-access-control/>.

Extreme Application Analytics

EAA, formerly Purview™, is a network powered application analytics and optimization solution that captures and analyzes context-based application traffic to deliver meaningful intelligence about applications, users, locations, and devices. EAA provides data to show how applications are being used.

This can be used to better understand customer behavior on the network, identify the level of user engagement, and assure business application delivery to optimize the user experience. The software also provides visibility into network and application performance allowing IT to pinpoint and resolve performance issues in the infrastructure whether they are caused by the network, application, or server. Learn more about EAA at <http://www.extremenetworks.com/product/extremeanalytics/>.

Extreme Management Center

Extreme Management Center (XMC), formerly Netsight™, is a web-based control interface that provides centralized visibility into your network. XMC reaches beyond ports, VLANs, and SSIDs and provides detailed control of individual users, applications, and protocols. When coupled with wireless and Identity & Access Management products, XMC becomes the central location for monitoring and managing all the components in the infrastructure. Learn more about XMC at <http://www.extremenetworks.com/product/management-center/>.

ExtremeCloud

ExtremeCloud is a cloud-based network management Software as a Service (SaaS) tool. ExtremeCloud allows you to manage users, wired and wireless devices, and applications on corporate and guest networks. You can control the user experience with smarter edges – including managing QoS, call admission control, secure access policies, rate limiting, multicast, filtering, and traffic forwarding, all from an intuitive web interface. Learn more about ExtremeCloud at <http://www.extremenetworks.com/product/extremecloud/>.

ExtremeSwitching

ExtremeSwitching is the family of products comprising different switch types: **Modular** (X8 and 8000 series [formerly BlackDiamond] and S and K series switches); **Stackable** (X-series and A, B, C, and 7100 series switches); **Standalone** (SSA, X430, and D, 200, 800, and ISW series); and **Mobile Backhaul** (E4G). Learn more about ExtremeSwitching at <http://www.extremenetworks.com/products/switching-routing/>.

ExtremeWireless

ExtremeWireless products and solutions offer high-density WiFi access, connecting your organization with employees, partners, and customers everywhere they go. The family of wireless products and solutions includes APs, wireless appliances, and software. Learn more about ExtremeWireless at <http://www.extremenetworks.com/products/wireless/>.

ExtremeXOS

ExtremeXOS, a modular switch operating system, is designed from the ground up to meet the needs of large cloud and private data centers, service providers, converged enterprise edge networks, and everything in between. Based on a resilient architecture and protocols, ExtremeXOS supports network virtualization and standards-based SDN capabilities like VXLAN gateway, OpenFlow, and OpenStack Cloud orchestration. ExtremeXOS also supports comprehensive role-based policy. Learn more about ExtremeXOS at <http://www.extremenetworks.com/product/extremexos-network-operating-system/>.

FHSS

Frequency-Hopping Spread Spectrum is a transmission technology used in Local Area Wireless Network (LAWN) transmissions where the data signal is modulated with a narrowband carrier signal that 'hops' in a random but predictable sequence from frequency to frequency as a function of time over a wide band of frequencies. This technique reduces interference. If synchronized properly, a single logical channel is maintained. (Compare with *DSSS (Direct-Sequence Spread Spectrum)*.)

IBSS

An IBSS is the 802.11 term for an ad hoc network. See [ad hoc mode](#).

MIC

Message Integrity Check (or Code), also called 'Michael', is part of WPA and TKIP. The MIC is an additional 8-byte code inserted before the standard 4-byte ICV appended in by standard WEP to the 802.11 message. This greatly increases the difficulty in carrying out forgery attacks.

Both integrity check mechanisms are calculated by the receiver and compared against the values sent by the sender in the frame. If the values match, there is assurance that the message has not been tampered with.

netmask

A netmask is a string of 0s and 1s that mask, or screen out, the network part of an IP address, so that only the host computer part of the address remains. A frequently-used netmask is 255.255.255.0, used for a Class C subnet (one with up to 255 host computers). The ".0" in the netmask allows the specific host computer address to be visible.

PEAP

Protected Extensible Authentication Protocol is an IETF draft standard to authenticate wireless LAN clients without requiring them to have certificates. In PEAP authentication, first the user authenticates the authentication server, then the authentication server authenticates the user. If the first phase is successful, the user is then authenticated over the SSL tunnel created in phase one using EAP-Generic Token Card (EAP-GTC) or Microsoft Challenged Handshake Protocol Version 2 (MSCHAP V2). (See also [EAP-TLS/EAP-TTLS](#).)

SSL

Secure Socket Layer is a protocol for transmitting private documents using the Internet. SSL works by using a public key to encrypt data that is transferred over the SSL connection. SSL uses the public-and-private key encryption system, which includes the use of a digital certificate. SSL is used for other applications than SSH, for example, OpenFlow.

syslog

A protocol used for the transmission of event notification messages across networks, originally developed on the University of California Berkeley Software Distribution (BSD) TCP/IP system implementations, and now embedded in many other operating systems and networked devices. A device generates a messages, a relay receives and forwards the messages, and a collector (a syslog server) receives the messages without relaying them.

syslog uses the UDP as its underlying transport layer mechanism. The UDP port that has been assigned to syslog is 514. (RFC 3164)

Index

C

Conventions
 notice icons 8
 text 8

D

documentation
 feedback 9
Documentation location 10

F

features
 platform-specific 8

O

Open Source Declaration 10

P

platform dependence 8

S

support 9

T

technical support
 contacting 9