



# ExtremeRouting SLX 9740 Hardware Installation Guide

9036696-01 Rev AH  
February 2024



Copyright © 2023 Extreme Networks, Inc. All rights reserved.

## Legal Notice

Extreme Networks, Inc. reserves the right to make changes in specifications and other information contained in this document and its website without prior notice. The reader should in all cases consult representatives of Extreme Networks to determine whether any such changes have been made.

The hardware, firmware, software or any specifications described or referred to in this document are subject to change without notice.

## Trademarks

Extreme Networks and the Extreme Networks logo are trademarks or registered trademarks of Extreme Networks, Inc. in the United States and/or other countries.

All other names (including any product names) mentioned in this document are the property of their respective owners and may be trademarks or registered trademarks of their respective companies/owners.

For additional information on Extreme Networks trademarks, see: [www.extremenetworks.com/company/legal/trademarks](https://www.extremenetworks.com/company/legal/trademarks)

## Open Source Declarations

Some software files have been licensed under certain open source or third-party licenses.

End-user license agreements and open source declarations can be found at: <https://www.extremenetworks.com/support/policies/open-source-declaration/>



# Table of Contents

---

Preface.....	vi
Text Conventions.....	vi
Documentation and Training.....	vii
Getting Help.....	viii
Subscribe to Product Announcements.....	viii
Providing Feedback.....	ix
<b>About this Document.....</b>	<b>10</b>
What is new in this document.....	10
Supported hardware and software.....	10
SLX 9740 Router License Option.....	10
<b>Device Overview.....</b>	<b>13</b>
ExtremeRouting SLX 9740 Product Introduction.....	13
Hardware features.....	13
Device management options.....	15
<b>Power Supplies.....</b>	<b>17</b>
Precautions specific to power supplies.....	17
Power Supplies for Use with Your Device.....	17
1600 W AC Power Supplies.....	18
1600 W DC Power Supply.....	18
<b>Preparing for the Installation.....</b>	<b>19</b>
Preparing for the Installation.....	19
Safety precautions.....	20
General precautions.....	20
ESD precautions.....	21
Power precautions.....	22
Lifting precautions.....	22
Laser precautions.....	23
Shipping carton contents.....	23
Operating Environment Requirements.....	23
Meeting Building and Electrical Codes.....	23
Setting up the Wiring Closet.....	24
Controlling the Temperature.....	25
Controlling the Humidity Level.....	26
Protecting Your System from ESD (Electrostatic Discharge).....	26
Rack Specifications and Recommendations.....	26
Mechanical Recommendations for the Rack.....	26
Grounding the Rack.....	27
Providing Adequate Space for the Rack.....	27
Securing the Rack.....	27
Meeting Power Requirements.....	28

Power Supply Requirements.....	28
Requirements for Power Cords.....	28
UPS (Uninterruptible Power Supply) Requirements.....	29
Following Applicable Industry Standards.....	30
<b>Installing Your Device.....</b>	<b>31</b>
Installing Your Device.....	31
Safety Considerations for Installing Switches.....	32
What You Will Need for the Installation.....	32
Attaching the Switch to a Rack.....	33
Attaching the Device to a Four-Post Rack.....	33
Attaching the Device to a Two-Post Rack.....	39
Installing Optional Components.....	44
Pluggable Transceiver Modules.....	44
Optical Cables.....	44
Breakout cables .....	44
Installing Internal Power Supplies.....	45
Installing a 1600 W Internal AC Power Supply.....	46
Installing a 1600 W Internal DC Power Supply.....	49
Powering up the Device.....	52
Connecting Network Interface Cables.....	53
<b>Activating and Verifying the Switch.....</b>	<b>54</b>
Establishing a serial connection .....	54
Configuring the Switch for Use.....	56
<b>Transceivers and Cables.....</b>	<b>57</b>
Supported transceivers and cables.....	57
Time and items required.....	57
Precautions specific to transceivers and cables.....	58
Cleaning the fiber-optic connectors.....	58
Managing cables.....	59
Installing a QSFP28 transceiver.....	59
Replacing a QSFP28 transceiver.....	61
Breakout cables.....	62
Verifying transceiver operation.....	63
<b>Monitoring the Device.....</b>	<b>64</b>
Monitoring Overview.....	64
LED activity interpretation.....	64
LED indicators .....	65
RJ-45 Management Port LEDs.....	66
QSFP28 Port LEDs.....	67
1600 W AC Power Supply LEDs.....	69
1600 W DC Power Supply LEDs.....	69
<b>Removing and Replacing Components .....</b>	<b>70</b>
Replacing Internal Power Supplies.....	70
Removing the Device from the Rack.....	70
<b>Fan Assemblies.....</b>	<b>74</b>
Fan assembly overview.....	74
Precautions specific to fan assemblies.....	75

Identifying the airflow direction.....	76
Replacing Fan Modules.....	77
Changing Airflow Direction.....	78
<b>ExtremeRouting SLX 9740 Technical Specifications.....</b>	<b>81</b>
SLX 9740 Software Specifications.....	81
Weights and Physical Dimensions.....	83
Acoustic Specifications .....	85
Power Options.....	86
Mean Time Between Failures (MTBF).....	86
CPU, Memory.....	86
Standards.....	87
Environmental Data.....	89
1600 W Power Supplies Technical Specifications.....	89
Power Cord Requirements for AC-Powered Switches and AC Power Supplies.....	91
<b>Safety and Regulatory Information.....</b>	<b>93</b>
Safety and Regulatory Information.....	93
Considerations Before Installing.....	93
General Safety Precautions.....	94
Maintenance Safety.....	94
Cable Routing for LAN Systems.....	95
Installing Power Supply Units and Connecting Power.....	96
Selecting Power Supply Cords.....	97
Battery Notice.....	97
<b>Regulatory Statements.....</b>	<b>99</b>
CE statement.....	99
China ROHS.....	99
BSMI statement (Taiwan).....	100
Canadian requirements.....	100
China CCC statement.....	101
Australia (RCM).....	101
Federal Communications Commission (FCC) Notice.....	101
Germany statement.....	102
KCC statement (Republic of Korea).....	102
Japan (VCCI Class A).....	102
Japan power cord .....	103
<b>Cautions and Danger Notices.....</b>	<b>104</b>
Cautions.....	104
General cautions.....	104
Danger Notices.....	111
General dangers.....	111



# Preface

---

Read the following topics to learn about:

- The meanings of text formats used in this document.
- Where you can find additional information and help.
- How to reach us with questions and comments.






## Text Conventions

---

Unless otherwise noted, information in this document applies to all supported environments for the products in question. Exceptions, like command keywords associated with a specific software version, are identified in the text.

When a feature, function, or operation pertains to a specific hardware product, the product name is used. When features, functions, and operations are the same across an entire product family, such as ExtremeSwitching switches or SLX routers, the product is referred to as *the switch* or *the router*.

**Table 1: Notes and warnings**

Icon	Notice type	Alerts you to...
	Tip	Helpful tips and notices for using the product
	Note	Useful information or instructions
	Important	Important features or instructions
	Caution	Risk of personal injury, system damage, or loss of data
	Warning	Risk of severe personal injury

**Table 2: Text**

Convention	Description
screen displays	This typeface indicates command syntax, or represents information as it is displayed on the screen.
The words <i>enter</i> and <i>type</i>	When you see the word <i>enter</i> in this guide, you must type something, and then press the Return or Enter key. Do not press the Return or Enter key when an instruction simply says <i>type</i> .
<b>Key names</b>	Key names are written in boldface, for example <b>Ctrl</b> or <b>Esc</b> . If you must press two or more keys simultaneously, the key names are linked with a plus sign (+). Example: Press <b>Ctrl+Alt+Del</b>
<i>Words in italicized type</i>	Italics emphasize a point or denote new terms at the place where they are defined in the text. Italics are also used when referring to publication titles.
<b>NEW!</b>	New information. In a PDF, this is searchable text.

**Table 3: Command syntax**

Convention	Description
<b>bold text</b>	Bold text indicates command names, keywords, and command options.
<i>italic text</i>	Italic text indicates variable content.
[ ]	Syntax components displayed within square brackets are optional. Default responses to system prompts are enclosed in square brackets.
{ <b>x</b>   <b>y</b>   <b>z</b> }	A choice of required parameters is enclosed in curly brackets separated by vertical bars. You must select one of the options.
<b>x</b>   <b>y</b>	A vertical bar separates mutually exclusive elements.
< >	Nonprinting characters, such as passwords, are enclosed in angle brackets.
...	Repeat the previous element, for example, <i>member [member...]</i> .
\	In command examples, the backslash indicates a “soft” line break. When a backslash separates two lines of a command input, enter the entire command at the prompt without the backslash.

## Documentation and Training

Find Extreme Networks product information at the following locations:

[Current Product Documentation](#)

[Release Notes](#)

[Hardware and software compatibility](#) for Extreme Networks products

[Extreme Optics Compatibility](#)

[Other resources](#) such as white papers, data sheets, and case studies

Extreme Networks offers product training courses, both online and in person, as well as specialized certifications. For details, visit [www.extremenetworks.com/education/](http://www.extremenetworks.com/education/).

## Getting Help

---

If you require assistance, contact Extreme Networks using one of the following methods:

### Extreme Portal

Search the GTAC (Global Technical Assistance Center) knowledge base; manage support cases and service contracts; download software; and obtain product licensing, training, and certifications.

### The Hub

A forum for Extreme Networks customers to connect with one another, answer questions, and share ideas and feedback. This community is monitored by Extreme Networks employees, but is not intended to replace specific guidance from GTAC.

### Call GTAC

For immediate support: (800) 998 2408 (toll-free in U.S. and Canada) or 1 (408) 579 2826. For the support phone number in your country, visit: [www.extremenetworks.com/support/contact](http://www.extremenetworks.com/support/contact)

Before contacting Extreme Networks for technical support, have the following information ready:

- Your Extreme Networks service contract number, or serial numbers for all involved Extreme Networks products
- A description of the failure
- A description of any actions already taken to resolve the problem
- A description of your network environment (such as layout, cable type, other relevant environmental information)
- Network load at the time of trouble (if known)
- The device history (for example, if you have returned the device before, or if this is a recurring problem)
- Any related RMA (Return Material Authorization) numbers

## Subscribe to Product Announcements

You can subscribe to email notifications for product and software release announcements, Field Notices, and Vulnerability Notices.

1. Go to [The Hub](#).
2. In the list of categories, expand the **Product Announcements** list.



3. Select a product for which you would like to receive notifications.
4. Select **Subscribe**.
5. To select additional products, return to the **Product Announcements** list and repeat steps 3 and 4.

You can modify your product selections or unsubscribe at any time.

---

## Providing Feedback

---

The Information Development team at Extreme Networks has made every effort to ensure the accuracy and completeness of this document. We are always striving to improve our documentation and help you work better, so we want to hear from you. We welcome all feedback, but we especially want to know about:

- Content errors, or confusing or conflicting information.
- Improvements that would help you find relevant information in the document.
- Broken links or usability issues.

If you would like to provide feedback, you can do so in three ways:

- In a web browser, select the feedback icon and complete the online feedback form.
- Access the feedback form at <https://www.extremenetworks.com/documentation-feedback/>.
- Email us at [documentation@extremenetworks.com](mailto:documentation@extremenetworks.com).

Provide the publication title, part number, and as much detail as possible, including the topic heading and page number if applicable, as well as your suggestions for improvement.



# About this Document

---

[What is new in this document](#) on page 10

[Supported hardware and software](#) on page 10

## What is new in this document

---

This is a new document.

## Supported hardware and software

---

The following table describes the ExtremeRouting SLX 9740 models:

**Table 4: SLX 9740 Switch Router Models**

Part number	Description	Introduced OS	Currently supported
SLX9740-40C, 9740-40C	Extreme SLX9740-40C switch router. Base unit with 40x100GE/40GE capable QSFP28 ports, 2 unpopulated power supply slots, 6 unpopulated fan slots	SLX-OS 20.2.1	Yes
SLX9740-40C-AC-F	Extreme SLX9740-40C-AC-F switch router. Base with 40x100GE/40GE capable QSFP28 ports, 2 AC power supplies, 6 fan modules.	SLX-OS 20.2.1	Yes
SLX9740-80C, 9740-80C	Extreme SLX9740-80C switch router. Base unit with 80x100GE/40GE capable QSFP28 ports, 4 unpopulated power supply slots, 4 unpopulated fan slots.	SLX-OS 20.2.1	Yes
SLX9740-80C-AC-F	Extreme SLX9740-80C-AC-F switch router. Base with 80x100GE/40GE capable QSFP28 ports, 4 AC power supplies, 4 fan modules.	SLX-OS 20.2.1	Yes

The following table lists the SLX 9740 supported power supplies FRU:

**Table 5: Supported SLX 9740 Power Supplies**

Part number	Description	Introduced OS	Currently supported
XN-ACPWR-1600W-F	SLX 9740 Fixed AC 1600W Power Supply Front to Back. Power cords not included.	SLX-OS 20.2.1	Yes
XN-ACPWR-1600W-R	SLX 9740 Fixed AC 1600W Power Supply Back to Front. Power cords not included.	SLX-OS 20.2.1	Yes
XN-DCPWR-1600W-F	SLX Fixed DC 1600W Power Supply Front to Back airflow. Power cords not included.	SLX-OS 20.2.1	Yes

The following table lists the SLX 9740 power specifications:

**Table 6: Supported SLX 9740 Power Specifications**

Part number	Description	Introduced OS	Currently supported
9740-40C, SLX9740-40C	AC Input: 100-120VAC, 50/60Hz, 7A Max (for PSU FSG059 for each PS)	SLX-OS 20.2.1	Yes
	AC Input: 200-240VAC, 50/60Hz, 4A Max (for PSU FSG059 and FSE023) or +/- 48vdc, 15A Max (for PSU FSK010) for each PSU		
9740-80C, SLX9740-80C	AC Input: 100-120VAC, 50/60Hz, 7A Max (for PSU FSG059 for each PSU)	SLX-OS 20.2.1	Yes
	AC Input: 200-240VAC, 50/60Hz, 4A Max (for PSU FSG059 and FSE023) or +/- 48vdc, 15A Max (for PSU FSK010) for each PSU, minimum *2		

The following table lists the SLX 9740 switch routers supported fan assemblies:

**Table 7: Supported SLX 9740 Fan Assemblies for all models**

Part number	Description	Introduced OS	Currently supported
XN-FAN-003-F	SLX 9740 FAN Front to Back airflow for SLX9740-40C	SLX-OS 20.2.1	Yes
XN-FAN-003-R	SLX 9740 FAN Back to Front airflow for SLX9740-40C	SLX-OS 20.2.1	Yes
XN-FAN-004-F	SLX 9740 FAN Front to Back airflow for SLX9740-80C	SLX-OS 20.2.1	Yes
XN-FAN-004-R	SLX 9740 FAN Back to Front airflow for SLX9740-80C	SLX-OS 20.2.1	Yes

The following table lists the SLX 9740 switch routers supported rack mount kit:

**Table 8: Supported SLX 9740 Router Rack Mount Kit**

Part number	Description
XN-2P-RKMT299	2 post Rail kit for SLX9740-40C
XN-2P-RKMT300	2 Post Rail Kit for SLX9740-80C
XN-4P-RKMT301	4 Post Rail Kit for SLX9740-80C
XN-4P-RKMT302	4 Post Rail Kit for SLX9740-40C

## SLX 9740 Router License Option

**Table 9: SLX 9740 Router License Option**

Part number	Description
SLX9740-ADV-LIC-P	Extreme SLX 9740-40C and SLX 9740-80C Advanced Feature License for BGP-EVPN and Integrated Application Hosting

For information about licensing option for SLX-OS support for SLX 9740 switch routers, reference *Extreme SLX-OS Software Licensing Guide*.



# Device Overview

---

[ExtremeRouting SLX 9740 Product Introduction](#) on page 13

[Hardware features](#) on page 13

[Device management options](#) on page 15

## ExtremeRouting SLX 9740 Product Introduction

---

The SLX 9740 are high density, fixed form factor switch routers with 80 x 100 GbE or 40 x 100 GbE ports to deliver the scale and performance needed to address the explosive growth in network bandwidth, devices and services.

This platform provides carrier-class advanced features that leverage proven Extreme Networks routing, MPLS, Carrier Ethernet, and VXLAN overlay technology, deployed in the most demanding service providers, internet exchange points (IXPs) and large enterprise data centers.

## Hardware features

---

The SLX 9740 switch routers run on the SLX-OS operating system.

The SLX 9740 switch routers comes in the following base models:

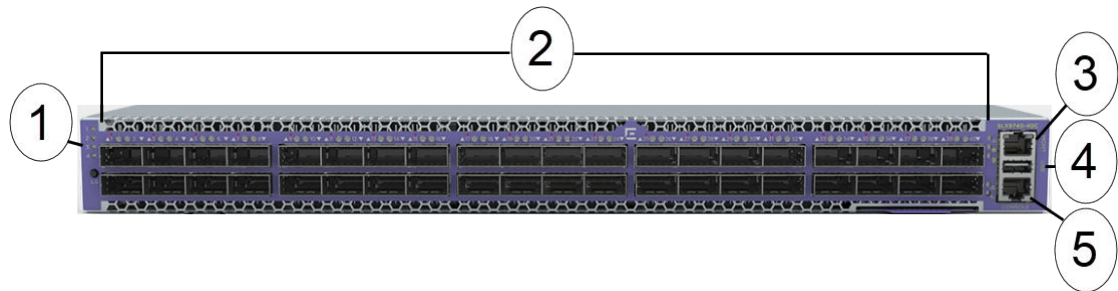
- SLX9740-40C, 9740-40C:
  - 40 100GE/40GE QSFP28 ports
  - RJ45 out-of-band 10/100/1000BASE-T management Ethernet port.
  - RJ45 serial console port used to connect a terminal and perform local management.
  - USB port for access to external storage.
  - Two power supply bays for 1600 W AC or DC power supplies
  - Six bays for replaceable fan modules.
- SLX9740-80C, 9740-80C:
  - 80 100GE/40GE QSFP28 ports
  - RJ45 out-of-band 10/100/1000BASE-T management Ethernet port.
  - RJ45 serial console port used to connect a terminal and perform local management.
  - USB port for access to external storage.
  - Four power supply bays for 1600 W AC or DC power supplies
  - Four bays for replaceable fan modules.

The SLX9740-40C-AC-F switch router includes:

- 40 100GE/40GE QSFP28 ports
- RJ45 out-of-band 10/100/1000BASE-T management Ethernet port.
- RJ45 serial console port used to connect a terminal and perform local management.
- USB port for access to external storage.
- Two 1600 W AC power supplies
- Six replaceable fan modules

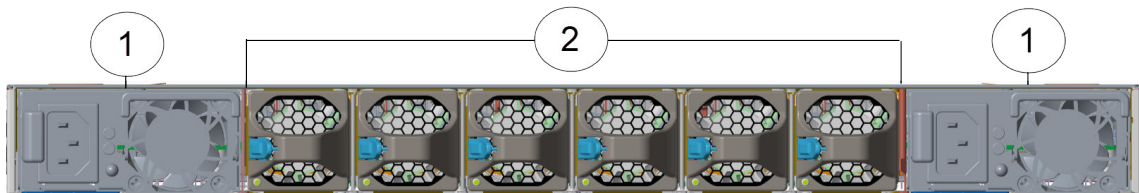
The SLX9740-80C-AC-F switch router includes:

- 80 100GE/40GE QSFP28 ports
- RJ45 out-of-band 10/100/1000BASE-T management Ethernet port.
- RJ45 serial console port used to connect a terminal and perform local management.
- USB port for access to external storage.
- Four 1600 W AC power supplies
- Four replaceable fan modules



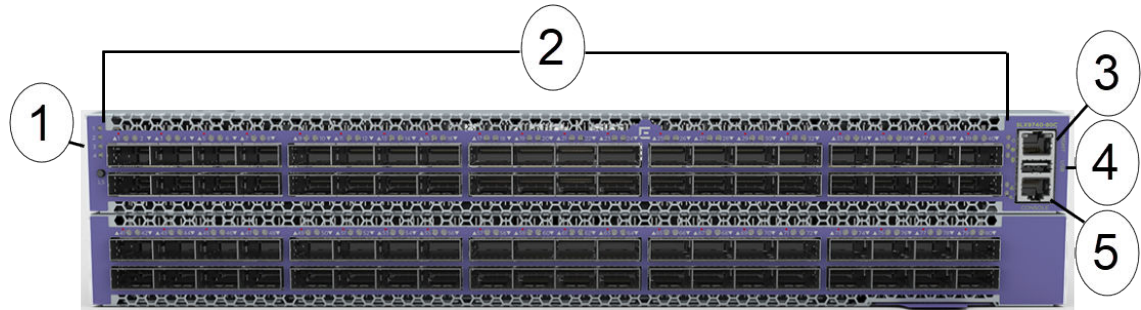
**Figure 1: SLX9740-40C Front Panel**

1 = LEDs	4 = USB port
2 = 100GE/40GE QSFP28 ports	5 = Console port
3 = Management port	



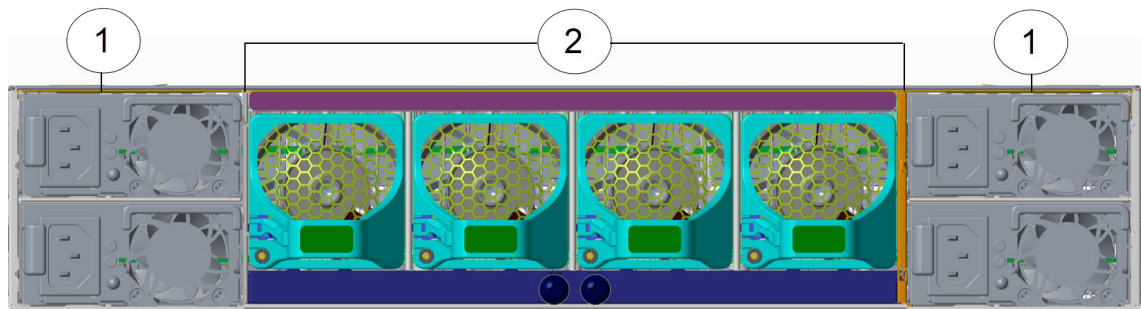
**Figure 2: SLX9740-40C Rear Panel**

1 = Power supplies	2 = Fan modules
--------------------	-----------------



**Figure 3: SLX9740-80C Front Panel**

1 = LEDs	4 = USB port
2 = 100GE/40GE QSFP28 ports	5 = Console port
3 = Management port	



**Figure 4: SLX9740-80C Rear Panel**

1 = Power supplies	2 = Fan modules
--------------------	-----------------

For more device details, refer to [ExtremeRouting SLX 9740 Technical Specifications](#) on page 81.

## Device management options

You can use the management functions built into the device to monitor the port status, physical status, and other information to help you analyze device performance and to accelerate system debugging. The device automatically performs a power-on self-test (POST) each time it is turned on.

You can manage the device using any of the management options listed in the following table.

**Table 10: Management options for the device**

Management tool	Out-of-band support	In-band support	Reference documents
Command line interface (CLI)	Ethernet or serial connection	N/A	<i>Extreme SLX-OS Management Configuration Guide</i>
REST or NETCONF/ YANG APIs.	Ethernet connection	Yes	<i>Extreme SLX-OS Management Configuration Guide</i>
Standard SNMP applications	Ethernet or serial connection	N/A	<i>Extreme SLX-OS Management Configuration Guide</i>





# Power Supplies

---

[Precautions specific to power supplies](#) on page 17

[Power Supplies for Use with Your Device](#) on page 17

## Precautions specific to power supplies

---



### Warning

Make sure that the power source circuits are properly grounded, then use the power cord supplied with the device to connect it to the power source.



### Warning

If the installation requires a different power cord than the one supplied with the device, make sure you use a power cord displaying the mark of the safety agency that defines the regulations for power cords in your country. The mark is your assurance that the power cord can be used safely with the device.



### Caution

Disassembling any part of the power supply and fan assembly voids the warranty and regulatory certifications. There are no user-serviceable parts inside the power supply and fan assembly.



### Caution

Ensure that the airflow direction of the power supply unit matches that of the installed fan tray. The power supplies and fan trays are clearly labeled with either a green arrow with an "E", or an orange arrow with an "I."



### Caution

If you do not install a module or a power supply in a slot, you must keep the slot filler panel in place. If you run the chassis with an uncovered slot, the system will overheat.

## Power Supplies for Use with Your Device

---

Each SLX 9740 switch router runs with two or four replaceable internal power supply units that provide all of the power needed for the device to operate. You can remove one power supply without interrupting the device's operation.

For more information, see the following topics.

- [1600 W AC Power Supplies](#) on page 18
- [1600 W DC Power Supply](#) on page 18

## 1600 W AC Power Supplies

Two 1600 W AC power supply options, with front-to-back or back-to-front airflow, are provided for the SLX 9740 switch routers.

- 1600W AC power supply - front-to-back airflow (part no. XN-ACPWR-1600W-F)
- 1600W AC power supply - back-to-front airflow (part no. XN-ACPWR-1600W-R)



### Note

AC power input cords are not provided with AC power supplies. You can order an appropriate cord from Extreme Networks or from your local supplier. The power cord must meet the requirements listed in [Power Cord Requirements for AC-Powered Switches and AC Power Supplies](#) on page 91

For information on installing or replacing an AC power supply, see [Installing a 1600 W Internal AC Power Supply](#) on page 46.

LEDs on the 1600 W AC power supply provide information on the unit's operational status. See [1600 W AC Power Supply LEDs](#) on page 69 for details.

## 1600 W DC Power Supply

One 1600 W DC power supply option, with front-to-back, is provided for the SLX 9740 switch routers.

- 1600W DC power supply - front-to-back airflow (part no. XN-DCPWR-1600W-F)

For information on installing or replacing a DC power supply, see [Installing a 1600 W Internal DC Power Supply](#) on page 49.

LEDs on the 1600 W DC power supply provide information on the unit's operational status. See [1600 W DC Power Supply LEDs](#) on page 69 for details.



# Preparing for the Installation

---

- [Preparing for the Installation](#) on page 19
- [Safety precautions](#) on page 20
- [Shipping carton contents](#) on page 23
- [Operating Environment Requirements](#) on page 23
- [Rack Specifications and Recommendations](#) on page 26
- [Meeting Power Requirements](#) on page 28
- [Following Applicable Industry Standards](#) on page 30

## Preparing for the Installation

---

Before you install your Extreme Networks equipment, careful planning can help ensure that it is used effectively and help prepare you for future growth.

Only qualified service personnel should install, maintain, or remove a device, chassis, or its components. Qualified service personnel have had appropriate technical training and experience that is necessary to be aware of the hazards to which they are exposed when performing a task and of measures to minimize the danger to themselves or other people.



### Note

Before installing or removing any components of the system, and before carrying out any maintenance procedures, read the safety information in [Safety and Regulatory Information](#) on page 93.

The information in this chapter is intended for the system administrator, network equipment technician, network manager, or facilities manager responsible for installing and managing the network hardware. The chapter assumes a working knowledge of local area network (LAN) operations, and a familiarity with communications protocols that are used on interconnected LANs.

This chapter covers the following aspects of site preparation:

1. [Operating Environment Requirements](#) on page 23  
Verify that your site meets all environmental and safety requirements.
2. [Rack Specifications and Recommendations](#) on page 26  
Ensure that mounting racks are safe and appropriate for the equipment.
3. [Managing cables](#) on page 59

Understand the different cabling options and select the ones that best address your needs.

4. [Meeting Power Requirements](#) on page 28

Ensure that power supplies are safe and appropriate for the equipment.

For details about the equipment's power requirements, see the [Power Supplies for Use with Your Device](#) on page 17.

5. [Following Applicable Industry Standards](#) on page 30

Understand the applicable standards and ensure that they are being followed.

## Safety precautions

---

When using this product, observe all danger, caution, and attention notices in this manual. The safety notices are accompanied by symbols that represent the severity of the safety condition.

Refer to Cautions and Danger Notices at the end of this guide for translations of safety notices for this product.

## General precautions

**Warning**

The procedures in this manual are for qualified service personnel.

**Warning**

Before beginning the installation, see the precautions in “Power precautions.”

**Warning**

Be careful not to accidentally insert your fingers into the fan tray while removing it from the chassis. The fan may still be spinning at a high speed.

**Caution**

Changes or modifications made to this device that are not expressly approved by the party responsible for compliance could void the user's authority to operate the equipment.

**Caution**

Disassembling any part of the power supply and fan assembly voids the warranty and regulatory certifications. There are no user-serviceable parts inside the power supply and fan assembly.

**Caution**

Make sure the airflow around the front, and back of the device is not restricted.

**Caution**

Ensure that the airflow direction of the power supply unit matches that of the installed fan tray. The power supplies and fan trays are clearly labeled with either a green arrow with an "E", or an orange arrow with an "I."

**Caution**

To protect the serial port from damage, keep the cover on the port when not in use.

**Caution**

Never leave tools inside the chassis.

**Caution**

If you do not install a module or a power supply in a slot, you must keep the slot filler panel in place. If you run the chassis with an uncovered slot, the system will overheat.

**Caution**

Use the screws specified in the procedure. Using longer screws can damage the device.

**Caution**

Do not install the device in an environment where the operating ambient temperature might exceed 50°C (122°F).

**Warning**

Batteries used for RTC/NVRAM backup are not located in operator-access areas. There is a risk of explosion if a battery is replaced by an incorrect type. Dispose of used components with batteries according to local ordinance and regulations.

## ESD precautions

**Warning**

For safety reasons, the ESD wrist strap should contain a series 1 megaohm resistor.

**Caution**

Static electricity can damage the chassis and other electronic devices. To avoid damage, keep static-sensitive devices in their static-protective packages until you are ready to install them.

**Caution**

Before plugging a cable into any port, be sure to discharge the voltage stored on the cable by touching the electrical contacts to ground surface.

## Power precautions

**Warning**

If the installation requires a different power cord than the one supplied with the device, make sure you use a power cord displaying the mark of the safety agency that defines the regulations for power cords in your country. The mark is your assurance that the power cord can be used safely with the device.

**Warning**

Disconnect the power cord from all power sources to completely remove power from the device.

**Warning**

This device might have more than one power cord. To reduce the risk of electric shock, disconnect all power cords before servicing.

**Warning**

To avoid high voltage shock, do not open the device while the power is on.

**Caution**

Use a separate branch circuit for each power cord, which provides redundancy in case one of the circuits fails.

**Caution**

Ensure that the device does not overload the power circuits, wiring, and over-current protection. To determine the possibility of overloading the supply circuits, add the ampere (amp) ratings of all devices installed on the same circuit as the device. Compare this total with the rating limit for the circuit. The maximum ampere ratings are usually printed on the devices near the input power connectors.

## Lifting precautions

**Warning**

Use safe lifting practices when moving the product.

**Warning**

Mount the devices you install in a rack as low as possible. Place the heaviest device at the bottom and progressively place lighter devices above.

**Warning**

Make sure the rack housing the device is adequately secured to prevent it from becoming unstable or falling over.

**Caution**

To prevent damage to the chassis and components, never attempt to lift the chassis using the fan or power supply handles. These handles were not designed to support the weight of the chassis.

## Laser precautions

**Warning**

All fiber-optic interfaces use Class 1 lasers.

**Warning**

Laser Radiation. Do Not View Directly with Optical Instruments. Class 1M Laser Products.

**Warning**

Use only optical transceivers that are qualified by Extreme Networks, Inc. and comply with the FDA Class 1 radiation performance requirements defined in 21 CFR Subchapter I, and with IEC 60825 and EN60825. Optical products that do not comply with these standards might emit light that is hazardous to the eyes.

## Shipping carton contents

When unpacking the device, verify that the contents of the shipping carton is complete. Save the shipping carton and packaging in the event you need to return the shipment.

- The SLX 9740 switch router comes with the following items:
  - XN-4P-RKMT301 or XN-4P-RKMT302 four-post rack mount kit
  - Accessory box (4-post rack ears, mounting screws)
  - SLX 9740 Switches Quick Reference

## Operating Environment Requirements

Verify that your site meets all environmental and safety requirements.

Virtually all areas of the United States are regulated by building codes and standards. During the early planning stages of installing or modifying your network, it is important that you develop a thorough understanding of the regulations that pertain to your location and industry.

## Meeting Building and Electrical Codes

Building and electrical codes vary depending on your location. Comply with all code specifications when planning your site and installing cable. This section lists resources for obtaining additional information.

For information about major building codes, consult the following organization:

International Code Council (ICC)  
5203 Leesburg Pike  
Falls Church, VA 22041 USA  
[www.iccsafe.org](http://www.iccsafe.org)

The organizations who are the authorities on electrical codes are listed in the table *Authorities on Electrical codes* below.

**Table 11: Authorities on Electrical Codes**

Organization	Address	Web Site URL
National Electrical Code (NEC) Classification (USA only) Recognized authority on safe electrical wiring. Federal, state, and local governments use NEC standards to establish their own laws, ordinances, and codes on wiring specifications. The NEC classification is published by the National Fire Protection Association (NFPA).	NFPA 1 Batterymarch Park Quincy, MA 02169 USA	<a href="http://www.nfpa.org">www.nfpa.org</a>
Underwriters' Laboratory (UL) Independent research and testing laboratory. UL evaluates the performance and capability of electrical wiring and equipment to determine whether they meet certain safety standards when properly used. Acceptance is usually indicated by the words "UL Approved" or "UL Listed."	UL 333 Pfingsten Road Northbrook, IL 60062 USA	<a href="http://www.ul.com">www.ul.com</a>
National Electrical Manufacturing Association (NEMA) (USA only) Organization of electrical product manufacturers. Members develop consensus standards for cables, wiring, and electrical components.	NEMA 1300 N. 17th Street Rosslyn, VA 22209 USA	<a href="http://www.nema.org">www.nema.org</a>
Electronic Components Industry Association (ECIA) Trade association that develops technical standards, disseminates marketing data, and maintains contact with government agencies in matters relating to the electronics industry.	ECIA 111 Alderman Drive Suite 400 Alpharetta, GA 30005 USA	<a href="http://www.ecianow.org">www.ecianow.org</a>
Federal Communications Commission (FCC) (USA only) Commission that regulates all interstate and foreign electrical communication systems that originate in the United States according to the Communications Act of 1934. The FCC regulates all U.S. telephone and cable systems.	FCC 445 12th Street S.W. Washington, DC 20554 USA	<a href="http://www.fcc.gov">www.fcc.gov</a>

## Setting up the Wiring Closet

Be aware of the following recommendations for your wiring closet:

- Make sure that your system is easily accessible for installation and service. See [Rack Specifications and Recommendations](#) on page 26 for more information.
- Use appropriate AC or DC power, power distribution, and grounding for your specific installation.



- Use a vinyl floor covering in your wiring closet. (Concrete floors accumulate dust, and carpets can cause static electricity.)
- Prevent unauthorized access to wiring closets by providing door locks. Install the equipment in a secured, enclosed, and restricted access location, ensuring that only qualified service personnel have access to the equipment.
- Provide adequate overhead lighting for easy maintenance.
- Be sure that each wiring closet has a suitable ground. All equipment racks and equipment installed in the closet should be grounded.
- Be sure that all system environmental requirements are met, such as ambient temperature and humidity.

**Note**

We recommend that you consult an electrical contractor for commercial building and wiring specifications.

## Controlling the Temperature

Extreme Networks equipment generates a significant amount of heat. It is essential that you provide a temperature-controlled environment for both performance and safety.

Install the equipment only in a temperature- and humidity-controlled indoor area that is free of airborne materials that can conduct electricity. Too much humidity can cause a fire. Too little humidity can produce electrical shock and fire.

Observe these additional thermal recommendations for the location where you plan to install your equipment:

- Ensure that the ventilation in the wiring closet is adequate to maintain a temperature no higher than 40°C (104°F). (Some configurations support higher operating temperatures. See Environmental Data in "Technical Specifications" for details.)
- Install a reliable air conditioning and ventilation system.
- Keep the ventilation in the wiring closet running during non-business hours; otherwise, the equipment can overheat.
- Maintain a storage temperature between -40°C (-40°F) and 70°C (158°F).

When internal system temperatures exceed the thermal shutdown temperature limit (typically about 20°C higher than normal system operating temperatures), the system's power supplies are turned off and the switch shuts down. The system remains in the OFF state until the system has sufficient time to cool and the internal thermal sensor measures a temperature lower than the maximum specified ambient temperature, at which time the system restarts automatically.

Alternately, you can restart the system immediately by removing and then restoring all line power to the system.

Safeguards are built into all Extreme Networks switches and power supply units to minimize the risk of fire.

## Controlling the Humidity Level

To maximize equipment life, keep operating humidity between 50% and 70% relative humidity (non-condensing) during typical operation.

The equipment can operate between 5% and 95% relative humidity (non-condensing) for short intervals.

## Protecting Your System from ESD (Electrostatic Discharge)

Your system must be protected from static electricity or ESD. Take the following measures to ensure optimum system performance:

- Remove materials that can cause electrostatic generation (such as synthetic resins) from the wiring closet.  
Check the appropriateness of floor mats and flooring.
- Connect metal chassis, conduit, and other metals to ground using dedicated grounding lines.
- Use electrostatically safe equipment.

If you are working with pluggable interface modules, wear an ESD-preventive wrist strap and connect the metal end to a grounded equipment rack or other source of ground.

## Rack Specifications and Recommendations

Racks should conform to conventional standards.

In the United States, use EIA Standard RS-310C: Racks, Panels, and Associated Equipment. In countries other than the United States, use IEC Standard 297. In addition, verify that your rack meets the basic mechanical, space, and earthquake requirements that are described in this section.

## Mechanical Recommendations for the Rack

Use equipment racks that meet the following mechanical recommendations:

- Use an open style, 19-inch rack to facilitate easy maintenance and to provide proper ventilation.
- Use a rack made of steel or aluminum.
- The rack should use the universal mounting rail hole pattern that is identified in EIC Standard 297.
- The rack should have designated earth grounding connections (typically on the base).
- The rack must meet earthquake safety requirements equal to that of the installed chassis.
- The mounting holes should be flush with the rails to accommodate the chassis.
- The rack should support approximately 276 kg (600 lb).

## Grounding the Rack

The rack must be properly grounded.

Use a rack grounding kit and a ground conductor that is carried back to earth or to another suitable building ground.

At a minimum, follow these guidelines to ground equipment racks to the earth ground:

- CAD weld appropriate wire terminals to building I-beams or earth ground rods.
- For a DC-powered switch, use a minimum 14 AWG stranded copper wire for grounding.

AC-powered switches do not need separate chassis grounding.

- Position the earth ground as close to the equipment rack as possible to maintain the shortest wiring distance possible.
- Use a ground impedance tester or micro-ohm meter to test the quality of earth ground connection at the chassis. This will ensure good grounding between the chassis, rack, and earth ground.



### Note

Because building codes vary worldwide, Extreme Networks strongly recommends that you consult an electrical contractor to ensure proper equipment grounding for your specific installation.

## Providing Adequate Space for the Rack

Provide enough space in front of and behind the switch so that you can service it easily.

Allow a minimum of 48 inches (122 cm) in front of the rack and 30 inches (76 cm) behind the rack. When using a relay (two-post) rack, provide a minimum of 24 inches (61 cm) of space behind the mounted equipment. Extra room on each side is optional.



### Warning

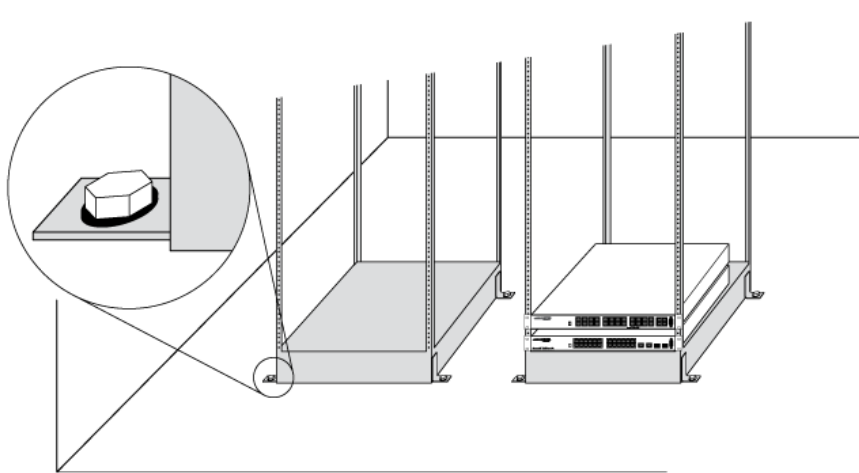
Extreme Networks switches do not have a switch for turning power to the unit on and off. For systems using an AC power supply, power to the switch is disconnected by removing the wall plug from the electrical outlet.

Be sure that cables and other equipment do not block the switch's air intake or outflow.

Depending on other conditions in the equipment room, it may be possible to install the switches closer to each other; consult your Extreme Networks Customer Support representative for guidance.

## Securing the Rack

The rack should be attached to the wiring closet floor with 9.5 mm (3/8 in) lag screws or equivalent hardware. The floor under the rack should be level within 5 mm (3/16 in). Use a floor-leveling cement compound if necessary or bolt the racks to the floor as shown.



**Figure 5: Properly Secured Rack**

Brace open equipment racks if the channel thickness is less than 6.4 mm (1/4 in).

## Meeting Power Requirements

Observe the following requirements and precautions for powering your hardware.

### Power Supply Requirements

Follow these recommendations when you plan power supply connections for your equipment:

- Place the equipment in an area that accommodates the power consumption and component heat dissipation specifications.
- Be sure that your power supply meets the site DC power or AC power requirements of the network equipment.
- When you connect power to installed equipment, do not make this connection through an extension cord or power strip.
- If your switch includes more than one power supply, connect each power supply to a different, independent power source.

If a power source fails, it will affect only the switch power supply to which it is connected. If all switch power supplies are connected to a single power source, the entire switch is vulnerable to a power source failure.

- In regions that are susceptible to electrical storms, we recommend that you plug your system into a surge suppressor.

For detailed power specifications for your equipment, see [ExtremeRouting SLX 9740 Technical Specifications](#) on page 81.

### Requirements for Power Cords

Most ExtremeSwitching devices do not ship with power cords. Visit [www.extremenetworks.com/product/powercords/](http://www.extremenetworks.com/product/powercords/) for information on selecting and

purchasing the correct power cords for use with specific Extreme Networks equipment. The web page provides specifications for power cords in each country so that you can purchase cords locally.

## UPS (Uninterruptible Power Supply) Requirements

A UPS (uninterruptible power supply) is a device that sits between a power supply (such as a wall outlet) and a device (such as a switch) to prevent outages, sags, surges, and bad harmonics from adversely affecting the performance of the device.

A UPS traditionally can perform the following functions:

- Absorb relatively small power surges.
- Smooth out noisy power sources.
- Continue to provide power to equipment during line sags.
- Provide power for a period of time after a blackout has occurred.

In addition, some UPS devices or UPS-plus-software combinations provide the following functions:

- Automatically shut down equipment during long power outages.
- Monitor and log power supply status.
- Display the voltage (current draw) of the equipment.
- Restart equipment after a long power outage.
- Display the voltage currently on the line.
- Provide alarms on certain error conditions.
- Provide short-circuit protection.

### *Selecting a UPS*

To determine UPS requirements for your switch, answer these questions:

- What are the amperage requirements?
- What is the longest potential time period that the UPS would be required to supply backup power?
- Where will the UPS be installed?
- What is the maximum transition time that the installation will allow? (See [Providing a Suitable UPS Transition Time](#) on page 30 .)



#### **Note**

We recommend that you use a UPS that provides online protection.

### *Calculating Volt-Amperage Requirements*

To determine the size of UPS that you need:

1. Locate the voltage and amperage requirements for each piece of equipment. These numbers are usually found on a sticker on the back or bottom of your equipment.

2. Multiply the numbers together to get Volt-Amperes (VA):

$VA = \text{Volts} \times \text{Amperes}$

3. Add the VA from all the pieces of equipment together to find the total VA requirement.

To determine the minimum volt-ampere requirements for your UPS, we recommend that you add 30% to the total.

#### *Providing a Suitable UPS Transition Time*

*UPS transition time* is the time required for the UPS to change from providing AC power derived from the utility (or mains) supply to providing AC power derived from the battery backup. UPS transition time is sometimes called *UPS transfer time*.

UPS transition times vary between UPS models and implementations, but shorter transition times are preferred. For Extreme Networks stacking products, we recommend a UPS transition time of 20 milliseconds or less to ensure optimum performance and minimize service interruptions.

For high-availability and fault-tolerant installations in which the switches use redundant power supply units (PSUs), we recommend that each PSU in a switch be connected to a different UPS and that each UPS be powered by an independent AC supply. This will prevent service interruptions when a power source is lost, or when a UPS unit fails. (Note that a single, appropriately sized UPS can power PSUs in multiple switches. The recommendation is simply that for any given switch, the two PSUs should be connected to different UPS units.)

## Following Applicable Industry Standards

---

Always follow applicable industry standards.

For more information, see the following ANSI/TIA/EIA standards:

- ANSI/TIA/EIA-568-A—the six subsystems of a structured cabling system
- ANSI/TIA/EIA-569-A—design considerations
- ANSI/TIA/EIA-606—cabling system administration
- ANSI/TIA/EIA-607—commercial building grounding and bonding requirements

You can access these standards at: [www.ansi.org](http://www.ansi.org) or [www.tiaonline.org](http://www.tiaonline.org).



# Installing Your Device

---

- [Installing Your Device](#) on page 31
- [Safety Considerations for Installing Switches](#) on page 32
- [What You Will Need for the Installation](#) on page 32
- [Attaching the Switch to a Rack](#) on page 33
- [Installing Optional Components](#) on page 44
- [Installing Internal Power Supplies](#) on page 45
- [Powering up the Device](#) on page 52
- [Connecting Network Interface Cables](#) on page 53

## Installing Your Device

---

Before you attempt to install or remove an Extreme Networks switch or router, read the precautions in [Safety Considerations for Installing Switches](#) on page 32.

Extreme Networks switch routers fit into standard 19-inch equipment racks.

A four-post rack-mounting kit is provided with the device. A two-post kit can be ordered separately.

The installation process includes the following tasks:

1. Prepare to install the device.  
See [What You Will Need for the Installation](#) on page 32.
2. Install the device in the rack.  
See [Attaching the Switch to a Rack](#) on page 33.
3. Install optional components: optical transceivers and cables.  
See the instructions in [Installing Optional Components](#) on page 44.
4. If your device does not come with an installed internal power supply, install one or two power supplies.  
See [Installing Internal Power Supplies](#) on page 45.



### Note

Be aware of whether the power supply you are installing is AC-powered or a DC-powered. The installation instructions are different depending upon what type of power is used.

5. Power up the device.  
See [Powering up the Device](#) on page 52.

6. Connect network interface cables.

See [Connecting Network Interface Cables](#) on page 53.

7. Perform initial network connection and configuration.

See [Establishing a serial connection](#) on page 54 and [Configuring the Switch for Use](#) on page 56.

---

## Safety Considerations for Installing Switches

---

Read the information in this chapter thoroughly before you attempt to install or remove an Extreme Networks switch.

Ensure that proper ESD (electrostatic discharge) controls are in use before switch maintenance is performed. This includes but is not limited to wrist straps that are grounded to the switch housing and earth grounds.



### Warning

Connect the chassis ground wire **before** you connect any DC power cables. Disconnect the ground wire **after** you disconnect all DC power cables.

Take care to load the equipment rack so that it is not top-heavy. Start installing equipment at the bottom of the rack and work up.

Do not cover vents that would restrict airflow.



### Note

See [Safety and Regulatory Information](#) on page 93 for additional safety information.

See [ExtremeRouting SLX 9740 Technical Specifications](#) on page 81 for additional information regarding regulatory compliance certifications.

---

## What You Will Need for the Installation

---

Ensure that you have followed the guidance in [Preparing for the Installation](#) on page 19 and ensure that you have the appropriate people and tools on hand.

Installing Extreme Networks switch routers is easiest when there are two people to maneuver the device and attach mounting hardware.

Provide enough space in front of and behind the switch so that you can service it easily. Allow a minimum of 122 cm (48 in) in front of the rack and 76 cm (30 in) behind the rack.

If your device has internal power supplies, make sure they have the same airflow direction as the fans in the device.

Check *SLX 9740 Switch Router Quick Reference* to see what hardware is provided in the device packaging. Most Extreme Networks switches come with the following hardware:

- Two rack mounting brackets (ears) adaptable for either a front-mount or mid-mount installation.



- Two long mounting brackets (rails) or slider kits for mounting in a four-post installation.
- Screws for attaching mounting hardware to the switch housing.

You need the following additional tools and equipment. These are not provided with your device:

- Screwdriver for securing the rack mounting screws.
- #2 Phillips screwdriver to attach bracket screws that are provided with the device. We recommend using a magnetic screwdriver.
- AC power cord. For devices with removable AC power supplies, a separate power cord is needed for each installed power supply. The cord must meet the requirements listed in [Power Cord Requirements for AC-Powered Switches and AC Power Supplies](#) on page 91.
- ESD-preventive wrist strap for installing optional ports at the back of the device.
- Grounding lugs.

## Attaching the Switch to a Rack

---

To attach a switch to a four-post or two-post rack, follow the steps in the appropriate section:

- [Attaching the Device to a Four-Post Rack](#) on page 33
- [Attaching the Device to a Two-Post Rack](#) on page 39



### Note

- When you install Extreme Networks switches, we recommend that you have two people to maneuver the switch and the mounting hardware.
- Take care to load the rack so that it is not top-heavy. Start installing equipment at the bottom and work up.

After the switch is attached to the rack, refer to [Removing the Device from the Rack](#) on page 70 if you need to remove it.

## Attaching the Device to a Four-Post Rack

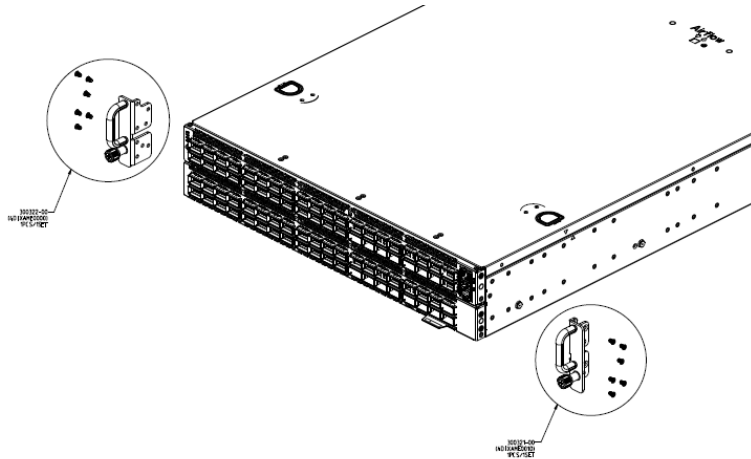
A four-post rack-mounting kit (XN-4P-RKMT301 for SLX9740-80C or XN-4P-RKMT302 for SLX9740-40C) is included in the box with your switch router. The kit contains an instruction sheet, along with the following components:

- Two slider assemblies including inner rail (member) or intermediate rail (member), and outer rail (member).
- Two front mounting ears with black thumb screws in the middle (for SLX9740-40C), or a black thumb screw and handle (for SLX9740-80C). These pieces attach directly to both sides of the device housing.
- Mounting ears - Black rack ears with a thumb screw in the middle (2 count).
- Black mounting ear screws (6 count for front two rack ears of SLX9740-40C and 12 count for front two rack ears of SLX9740-80C).

- Grounding screws - M4 screws to install the lug cables (not provided) to the rack on SLX9740-40c (4 count).
- Rail screws - M4 screws to secure the inner rail to the device (2 count).

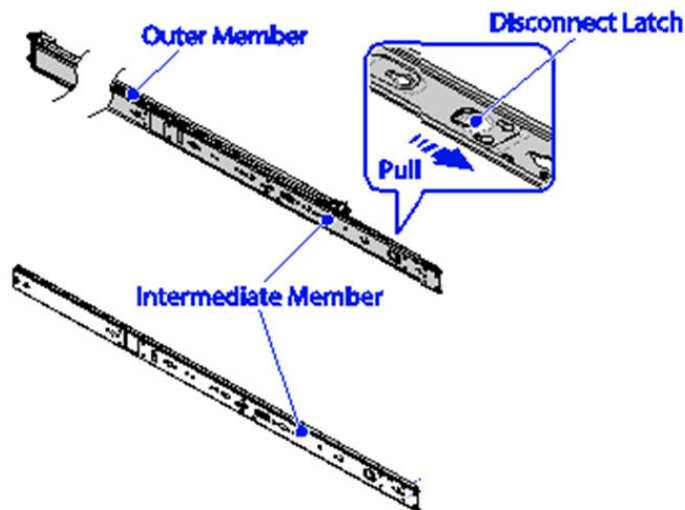
To attach your device to a four-post rack, follow these steps:

1. On the sides of the device, screw on the mounting ears. For SLX9740-80C, screw the mounting ears to the top of the switch/router, aligned with ports 1-40.



**Figure 6: Mounting ears**

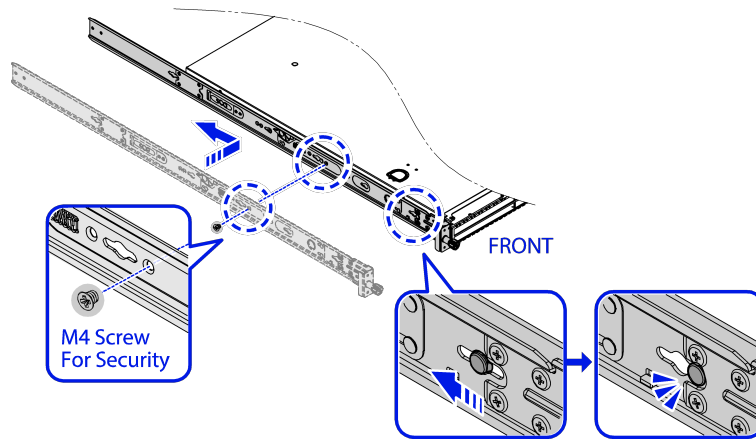
2. Pull the inner rail out until it is fully extended, then push the disconnect latch forward to release the inner rail from the middle rail and remove the inner rail.



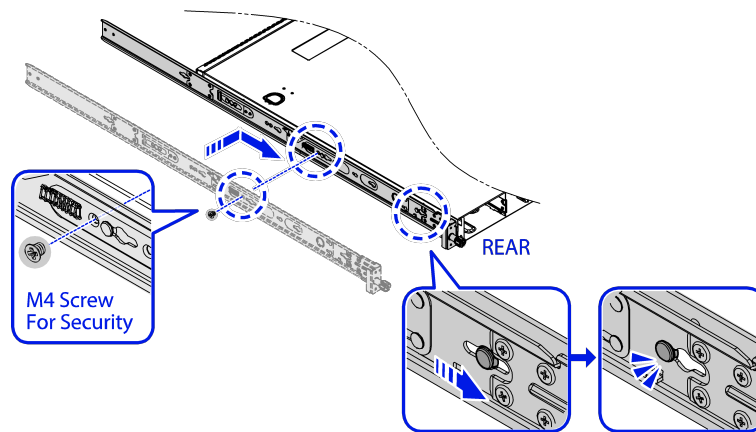
**Figure 7: Remove inner rail**

3. Align the hooks on the device with the holes in the inner rail, and then slide the inner rail backward until it is locked in place.

- Secure the inner rail to the device with one M4 rail screw per side. Repeat this step to install another inner rail.



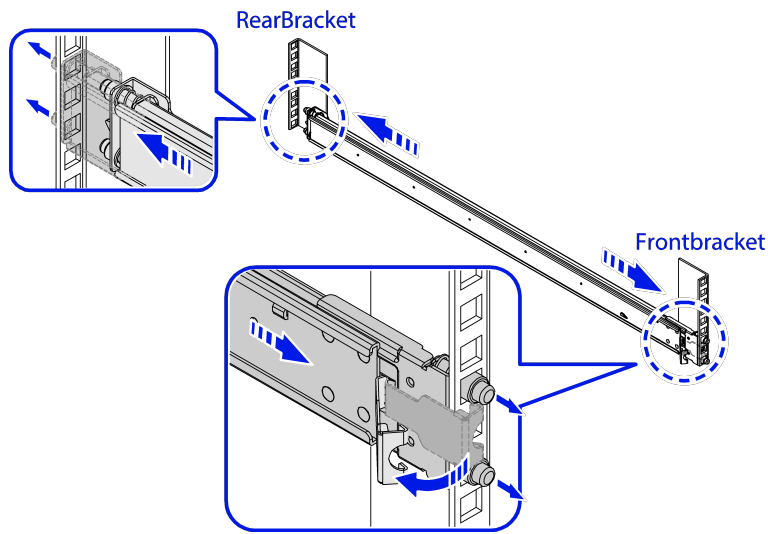
**Figure 8: Outer rail installation - front**



**Figure 9: Outer rail installation - rear**

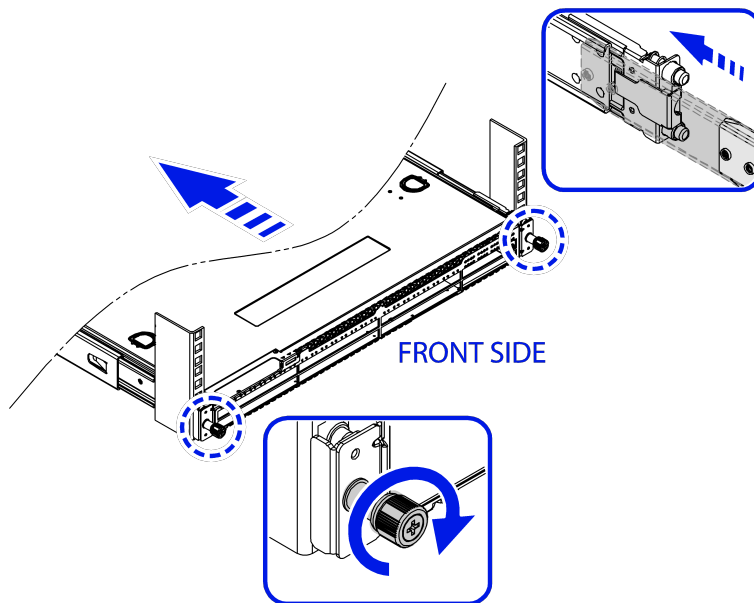
- For the front brackets, pull the latch and install the outer rail by aligning the hooks with the front rack holes. Then release the latch to lock the hooks into place.

6. For the rear brackets, align and push the rail firmly into the rear rack until it clicks into place. Make sure the L-shaped bracket is facing inward.

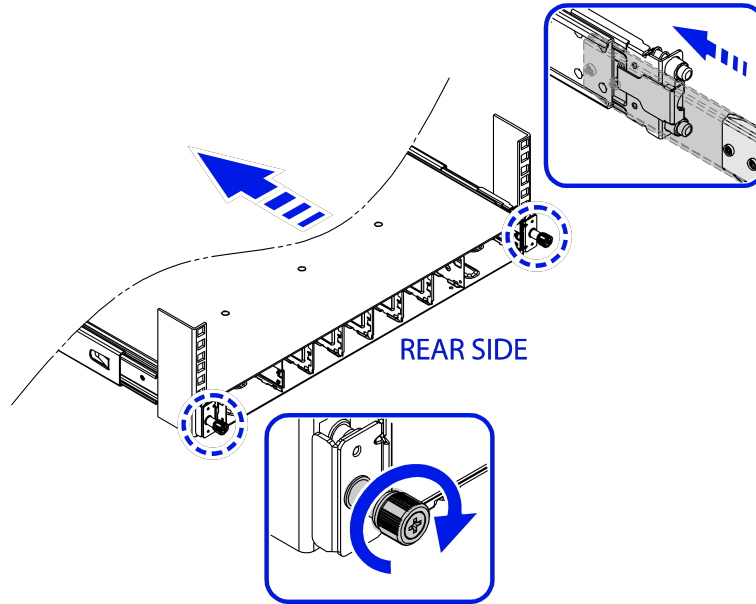


**Figure 10: Install outer rail**

7. Slide the inner rails on the device into the middle rails and push the device all the way to the rear of the rack.

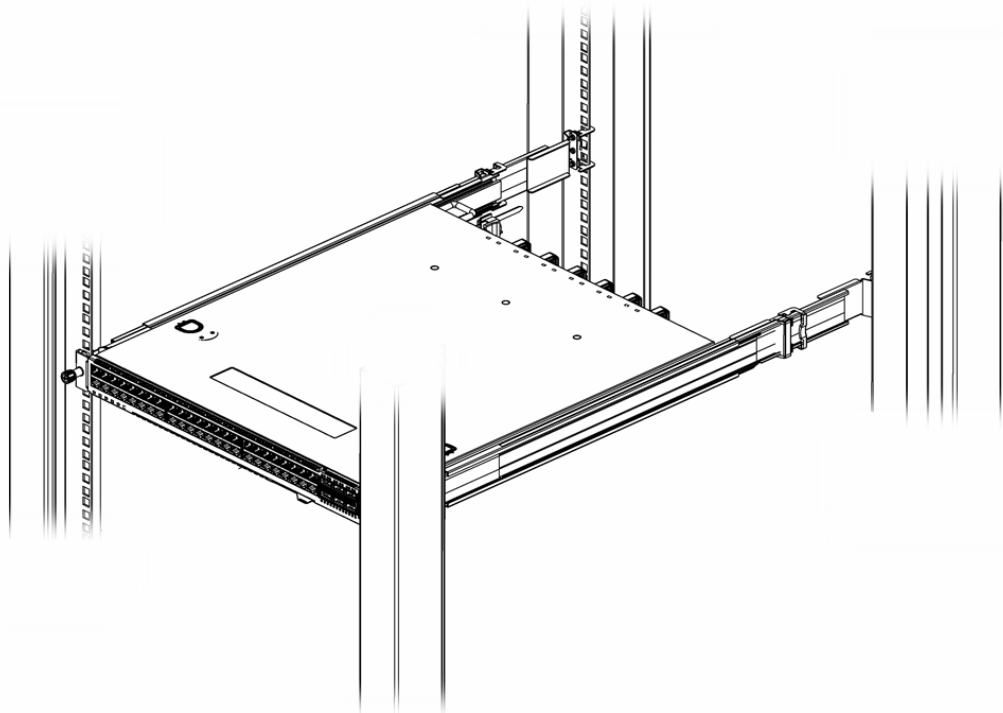


**Figure 11: Securing rails - front**



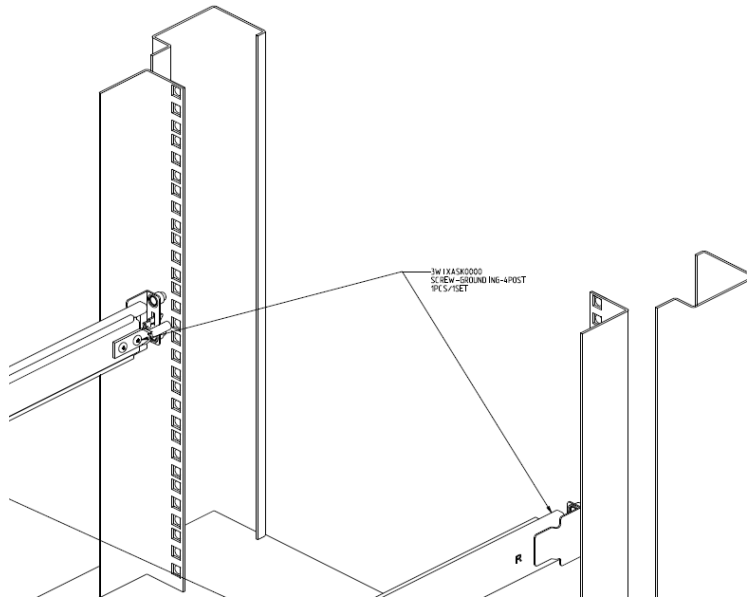
**Figure 12: Securing rails - rear**

8. Screw the mounting ear thumbscrews into the rack rails to hand tightness.  
The completed assembly is shown in the Figure *Completed Installation: Switch Router in 4-Post Rack*.



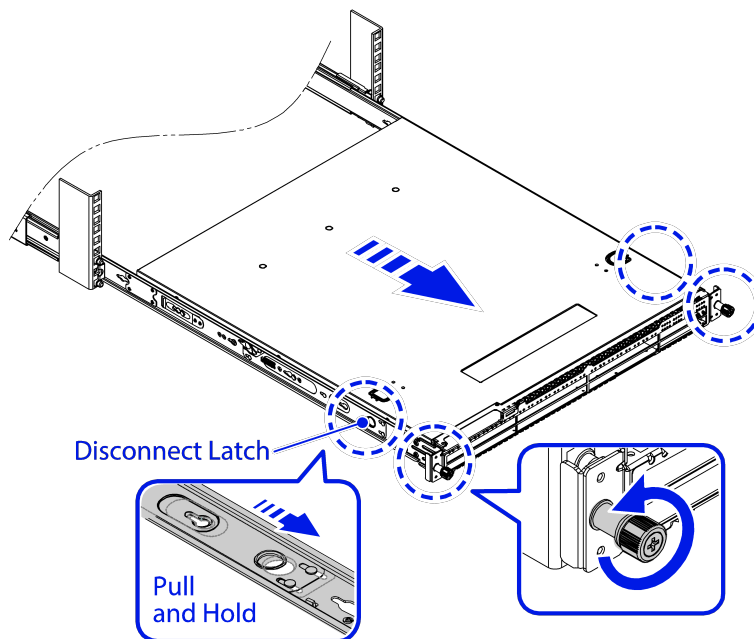
**Figure 13: Completed Installation: Switch Router in 4-Post Rack**

9. Install the ground lug cables to the rack using the four screws provided.



**Figure 14: 4-post grounding location**

10. Verify that the device is leveled and is firmly attached to the rack.
11. Push the disconnect latch to release the device when removing the device after it is fully extended.



**Figure 15: Disconnect latch for removal**

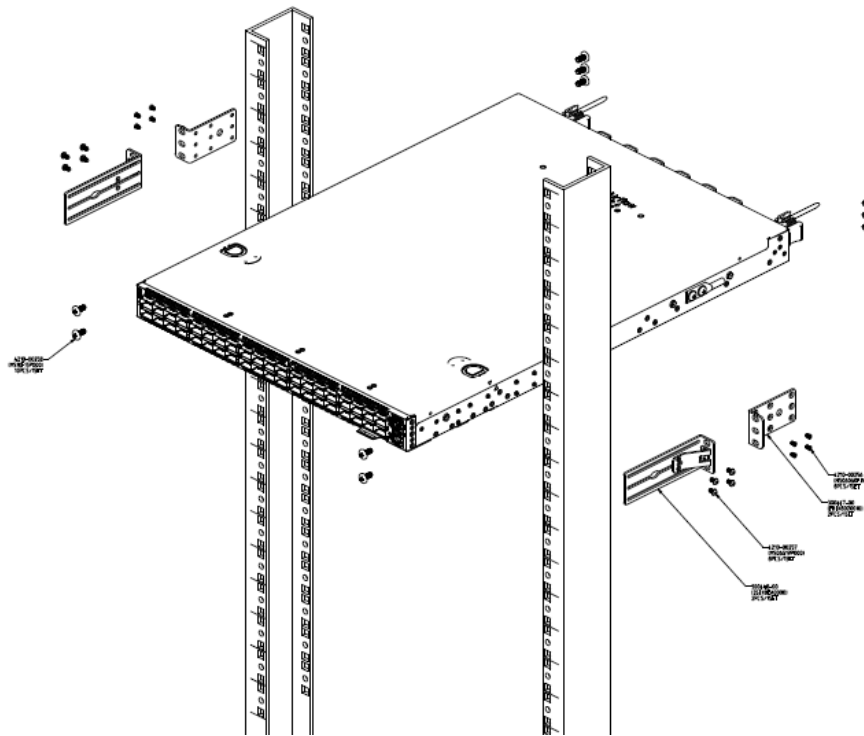
If your device comes with installed AC power supplies, skip to [Powering up the Device](#) on page 52 .

If your device does not have an installed power supply, install one or two power supplies using the instructions in [Installing a 1600 W Internal AC Power Supply](#) on page 46.

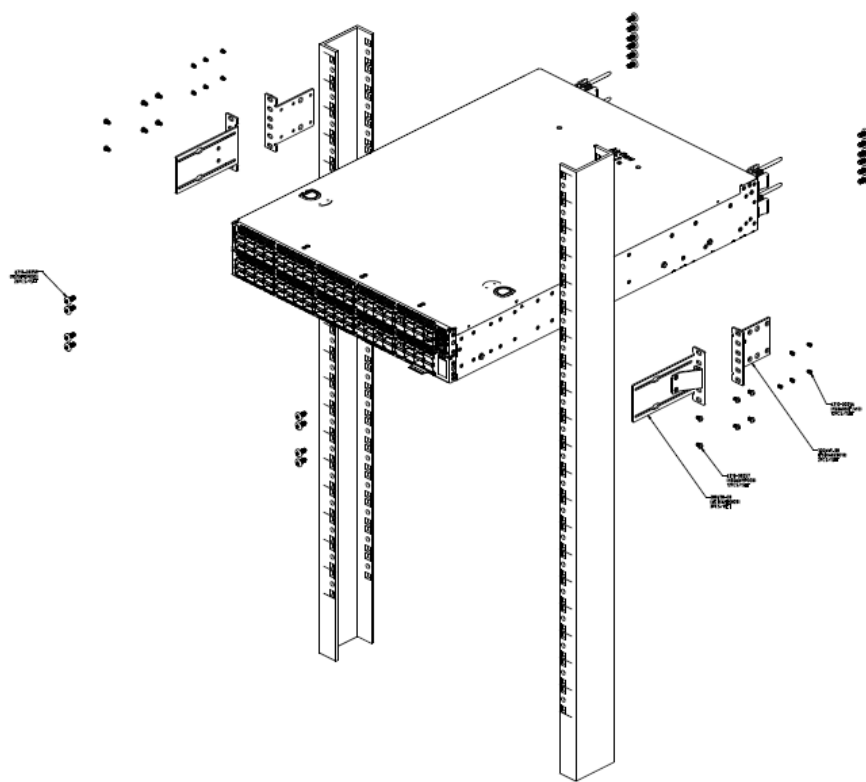
## Attaching the Device to a Two-Post Rack

You can attach your switch router to a two-post rack in mid-mount configuration.

Brackets for a two-post mount are not included in the box with your device. However, they can be ordered separately using part numbers XN-2P-RKMT299 or XN-2P-RKMT300.



**Figure 16: SLX9740-40C 2-post rack components**

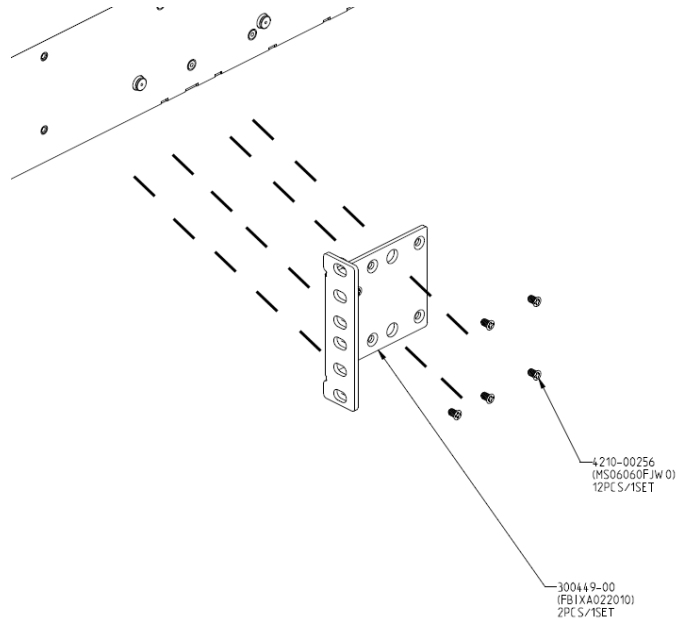


**Figure 17: SLX9740-80C 2-post rack components**



To attach your device to a two-post rack, follow these steps:

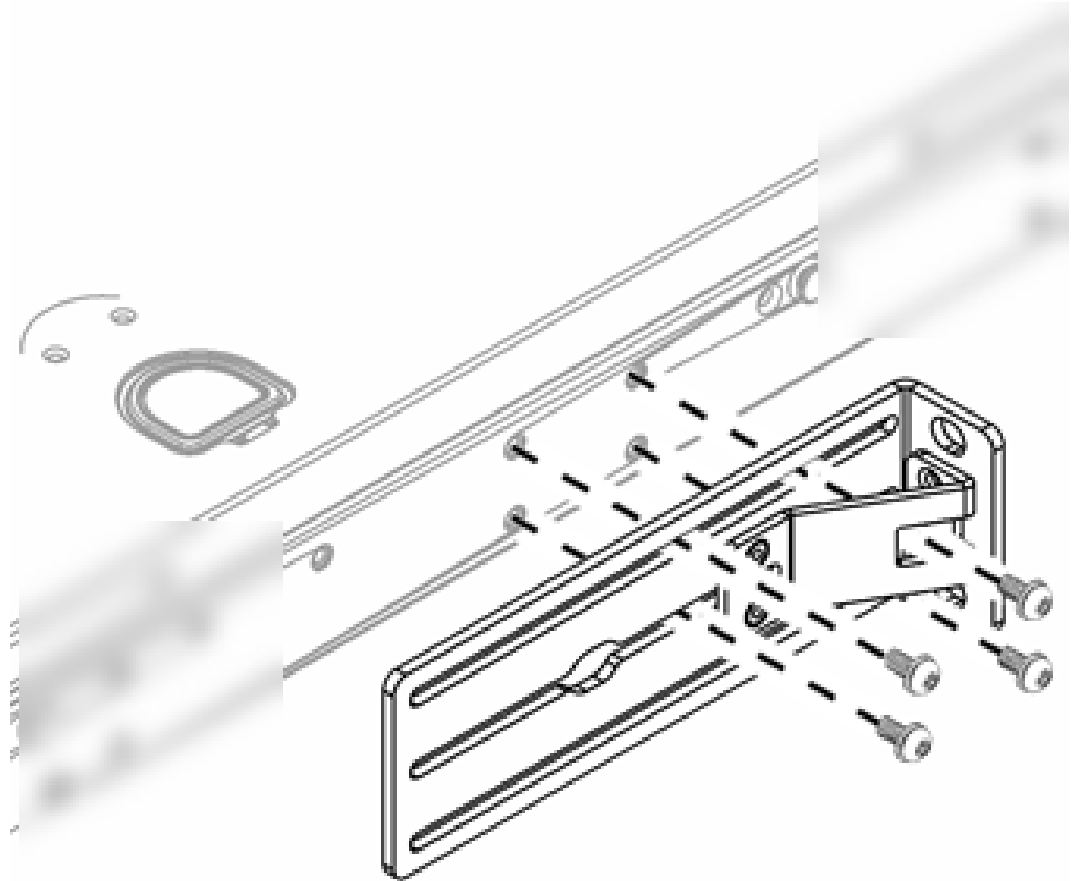
1. On one side of the device, attach one of the short mounting brackets to the switch router housing.
  - a. Position the bracket so that the flange (ear) is positioned slightly more than halfway between the front and back of the device, as shown in figure below:  
*Attaching a Short Mounting Bracket (Ear): Middle of Switch Router.*



**Figure 18: Attaching a Short Mounting Bracket (Ear): Middle of Switch Router**

- b. Use six small mounting screws (provided) to attach the bracket to the device.
2. Attach the other short mounting bracket to the other side of the switch router housing, as you did in step 2.

3. Attach a long mounting bracket to one side of the switch router housing and to the rack post.
  - a. Position the long bracket over the holes between the front and the middle of the device. Orient it so that its flange (ear) rests against the rack post. See the diagram below: *Attaching a Long Mounting Bracket: Middle of Switch Router.*

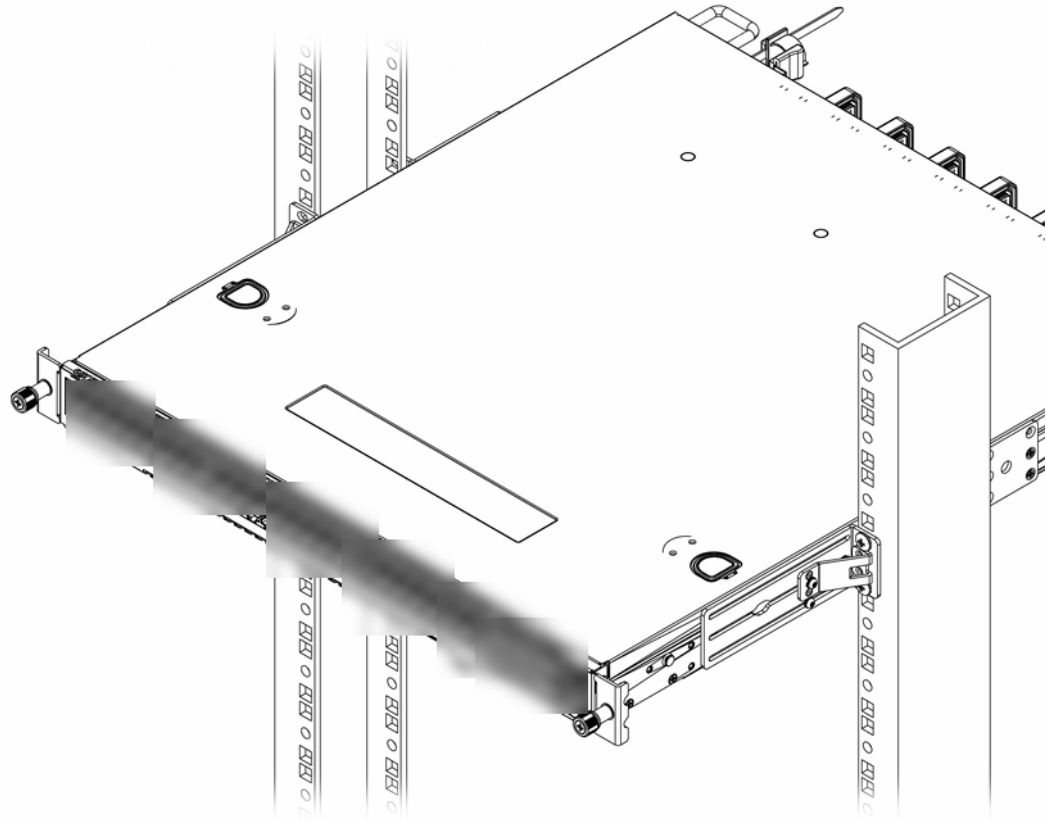


**Figure 19: Attaching a Long Mounting Bracket: Middle of Switch Router**

- b. Use six small mounting screws (provided) to attach the bracket to the device.
    - c. Secure the long bracket to the rack post.  
(Rack-mounting screws are not provided.)
  4. Repeat step 3 to attach the other long bracket on the other side of the device.
  5. Tilting the device slightly, lift it into the rack so that the mounting brackets align with the rack posts.  
If the device cannot be tilted (because other equipment is mounted directly above and below), remove one or both short mounting brackets from the device. Lift the device into position, secure the flanges (ears) on the long brackets to the rack posts, and then reattach the short brackets.

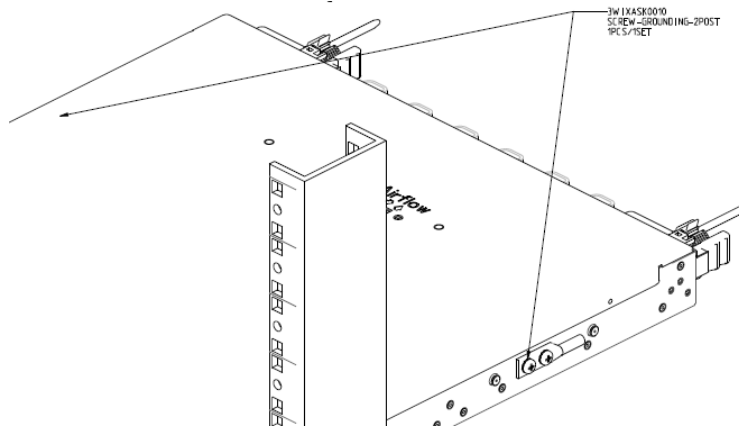
- Secure the flanges (ears) on both sides of the device to the rack posts, using screws that are appropriate for the rack.  
(Rack-mounting screws are not provided.)

The completed installation is shown in the diagrams below: *Two-Post Mid-Mount: Complete.*



**Figure 20: Two-Post Mid-Mount: Complete**

- For SLX9740-40C, install the ground lug cables to the rack using an M6 screw and the four screws provided (grounding screws for 2-post installation shipped with the switch in separate bag).



**Figure 21: SLX9740-40C grounding location**

- Verify that the device is level and is firmly attached to the rack.

If your device comes with installed AC power supplies, skip to the topic: [Powering up the Device](#) on page 52.

If your device does not have an installed power supply, install one or two power supplies using the instructions in [Installing Internal Power Supplies](#) on page 45.

## Installing Optional Components

After the device is secured to the rack, install optional components.

The SLX 9740 switch routers support the use of pluggable transceivers and cables in the QSFP+ and QSFP28 formats.

For a list of the optical components supported with SLX 9740 switch routers, see [Extreme Optics](#) website.

### Pluggable Transceiver Modules

Extreme Networks offers several optical transceiver modules for transmitting and receiving data over optical fiber rather than through electrical wires.

### Optical Cables

Direct-attach copper and fiber cables provide connections between unpopulated QSFP+ and QSFP28 ports.

### Breakout cables

The copper breakout cables are terminated with optical connectors and are available in 1m, 3m, 5m, or greater lengths. No additional connectors or cabling are required

when using the copper breakout. When using the fiber breakout cables, additional 10Gb optics are required.

The SLX 9740 groups ports together for breakout configuration. The port groups are called Port Macros (PM). Each PM consists of four contiguous ports. There are 9 PMs in the SLX 9740-40C and 18 PMs in the SLX 9740-80C. PM numbering begins with 0. PM0 has ports 0/1-0/4, PM1 has ports 0/5-0/8, PM2 has ports 0/9-0/12, and so on.

Only the odd ports can be split to 4x10Gb or 4x25Gb using the breakout cables: 0/1, 0/3, 0/9, 0/11, 0/13, 0/15, 0/17, 0/19, 0/21, 0/23, 0/25, 0/27, 0/29, 0/31, 0/33, 0/35, 0/37, 0/39, 0/41, 0/43, 0/49, 0/51, 0/53, 0/55, 0/57, 0/59, 0/61, 0/63, 0/65, 0/67, 0/69, 0/71, 0/73, 0/75, 0/77, and 0/79. Breaking out these ports using the breakout cables results in 72 interfaces for the SLX 9740-40C and 144 interfaces for the SLX 9740-80C.

Ports 5-8 and 45-48 cannot be broken up and are supported only in 100Gb. For any PM, 40Gb and 10Gb ports cannot coexist with 25Gb ports. The following configurations are not supported:

PM Configuration	Examples
If any port is configured as a 40Gb port or a 4x10Gb breakout port, a 4x25Gb breakout port cannot be configured unless the 40Gb ports are removed as part of the breakout operation.	<ul style="list-style-type: none"> <li>If 0/3 or 0/4 is a 40Gb port, 0/1 cannot be configured as a 4x25Gb breakout port.</li> <li>If 0/1 is a 4x10Gb breakout port, 0/3 cannot be configured as a 4x25Gb breakout port.</li> <li>If 0/3 is 4x10Gb breakout, 0/1 cannot be configured as a 4x25Gb breakout port.</li> <li>If 0/1 or 0/2 is 40Gb port, 0/1 can be configured as a 4x25Gb breakout port because 0/1 and 0/2 are removed.</li> <li>If 0/3 or 0/4 is 40Gb port, 0/3 can be configured as a 4x25Gb breakout port because 0/3 and 0/4 are removed.</li> </ul>
If a 4x25Gb breakout port is configured, no 40Gb or 4x10Gb ports can be configured.	<ul style="list-style-type: none"> <li>If 0/1 is configured as 4x25G breakout, 0/3 or 0/4 cannot be configured as a 40Gb port.</li> <li>If 0/1 is configured as 4x25Gb breakout, 0/3 cannot be configured as a 4x10Gb breakout port.</li> <li>If 0/3 is configured as 4x25Gb breakout port, 0/1 or 0/2 cannot be configured as a 40Gb port.</li> <li>If 0/3 is configured as a 4x25Gb breakout port, 0/1 cannot be configured as a 4x10Gb breakout port.</li> </ul>

## Installing Internal Power Supplies

If your device does not come with an installed internal power supply, you can install one or two power supplies.

The SLX 9740 switch routers supports 1600 W power supply units using either AC or DC power.

Follow the instructions in the following sections to install the appropriate power supply and connect power to the switch.

- [Installing a 1600 W Internal AC Power Supply](#) on page 46
- [Installing a 1600 W Internal DC Power Supply](#) on page 49

## Installing a 1600 W Internal AC Power Supply

To install a 1600 W AC power supply in a switch, follow these instructions.

All installed power supplies must have the same airflow direction (front-to-back or back-to-front) and must match the airflow direction of the installed fan modules.



### Warning

To prevent an electrical hazard, make sure that the AC power cord is not connected to the power supply before you install the power supply in the power supply bay.

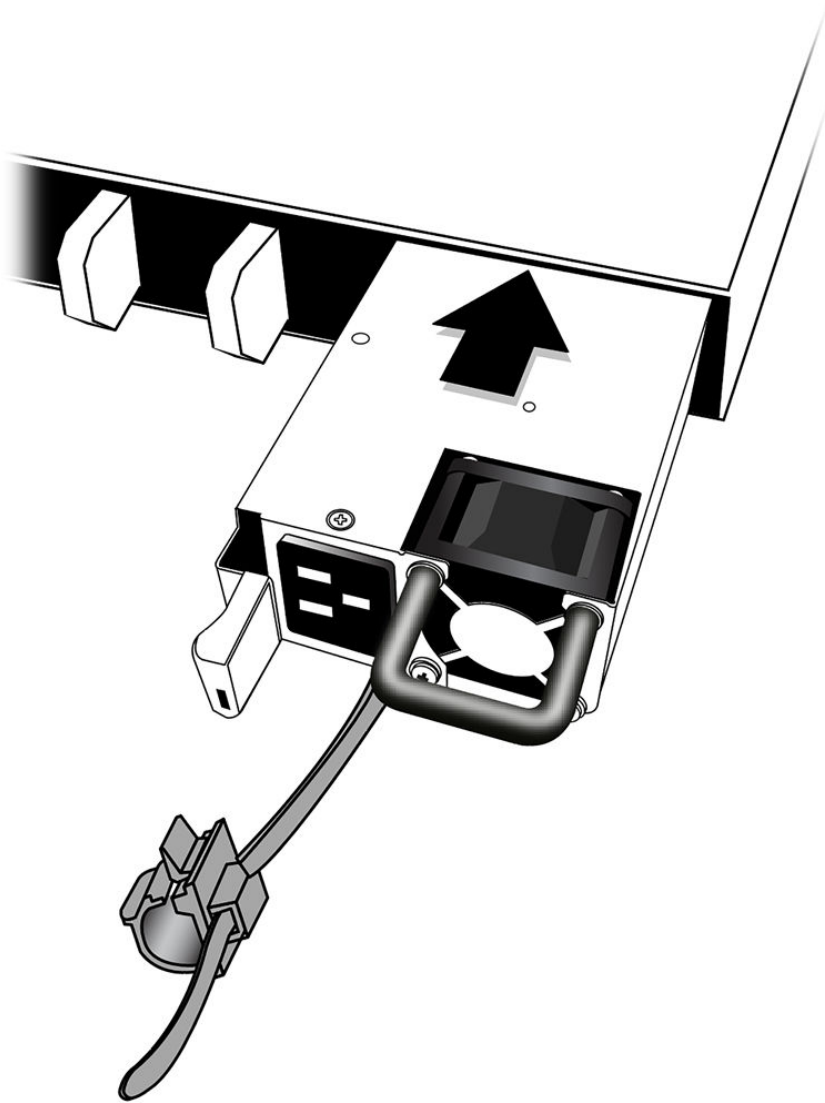


### Warning

Make sure that the AC power supply circuit is not overloaded. Use proper over-current protection, such as a circuit-breaker, to prevent over-current conditions.

1. If necessary, remove a blank panel from the back of the switch.
2. Verify that the new power supply is right side up.
3. Verify that the new power supply's airflow direction (front-to-back or back-to-front) is compatible with the other installed power supply (if any) and with the installed fan modules.

- Carefully slide the power supply all the way into the power supply bay:



**Figure 22: Installing a 1600 W AC Power Supply**

- Push the power supply in until the latch snaps into place.  
Do not slam the power supply into the switch.



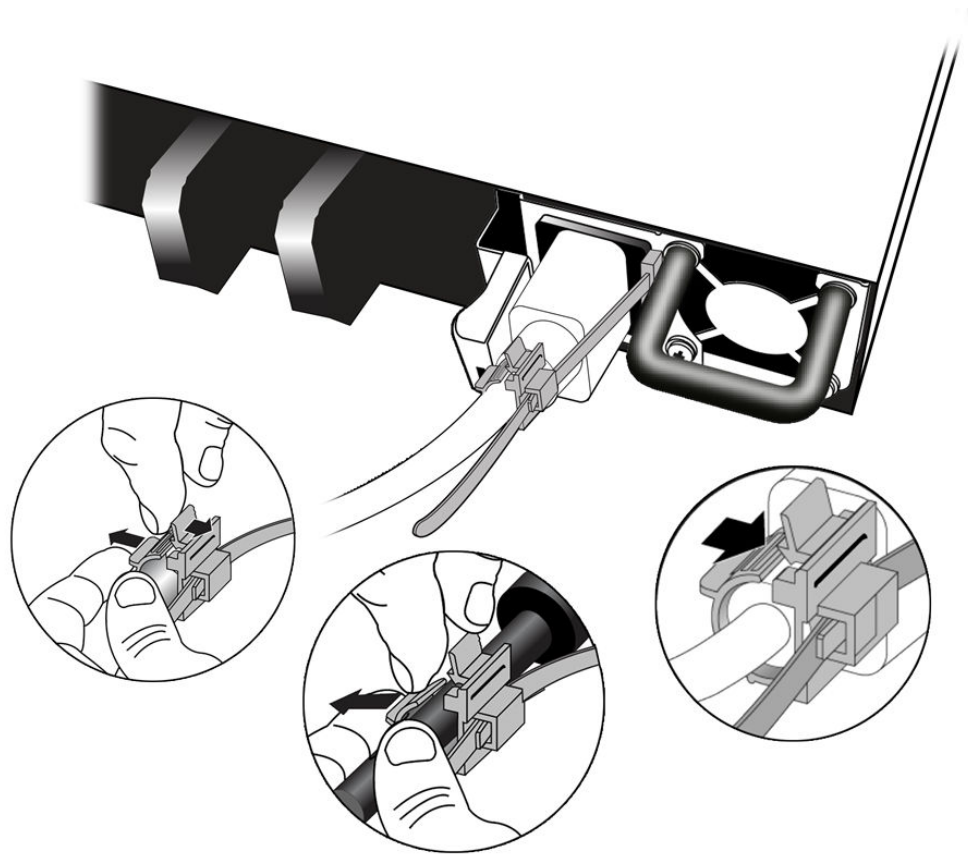
**Note**

If power supplies are not installed in both power supply bays, be sure to install a cover over the unoccupied bay. Unoccupied bays must always be covered to maintain proper system ventilation and EMI levels.

- Connect the AC power cord.
  - If necessary, slide the plastic cord retainer farther away from the back of the switch.
  - Connect the AC power cord to the input connector.

- c. Open the clip and slip it over the barrel of the connector.

The diagram below - *Power Supply with Power Cord and Retainer Attached* shows the power supply with the power cord and retainer in place.



**Figure 23: Power Supply with Power Cord and Retainer Attached**

- d. Snap the clip firmly around the connector.
7. Connect the other end of the power cord to an AC power outlet.



**Warning**

Always make sure that the source outlet is properly grounded before plugging the AC power cord into the AC power supply.

To install a second power supply, repeat this procedure.

When you are finished, follow the steps in [Powering up the Device](#) on page 52.



## Installing a 1600 W Internal DC Power Supply



### Caution

Make sure that the DC power supply circuit is not overloaded. Use proper overcurrent protection, such as a circuit breaker, to prevent overcurrent conditions. You may use up to a 30-Amp breaker.

To install a 1600 W DC power supply in a switch, perform the following tasks in the order listed:

1. Make sure you have the tools and materials you need.  
See [Required Tools and Materials for Installing a 1600 W DC Power Supply](#) on page 49.
2. Prepare the ground cable by stripping off the insulation.  
See [Preparing the Cables for a 1600 W DC Power Supply](#) on page 49.
3. Insert the power supply into the switch.  
See [Installing a 1600 W DC Power Supply](#) on page 50.
4. Connect the ground wire.  
See [Connecting the Ground Wire to a 1600 W DC Power Supply](#) on page 51.
5. Connect the power supply to the DC source voltage.  
See [Connecting a 1600 W DC Power Supply to the Source Voltage](#) on page 52.
6. Energize the DC circuit.

### *Required Tools and Materials for Installing a 1600 W DC Power Supply*

You need the following tools and materials to install or remove a 1600 W DC power supply in an SLX 9740 switch.

- A #6 AWG copper cable for grounding the power supply and a DC power input cable, which is provided, to connect the power supply to the DC power source. The ground connection is green or green with a yellow stripe.
- Connection hardware appropriate to the installation site:
  - Hardware for connecting the power wires to the DC source
  - Hardware for connecting the ground wire to the site grounding point
- Stripping tool
- #1 cross-head (Phillips) screwdriver
- ESD-preventive wrist strap
- Thermal protective gloves (for removal of a warm power supply)

### *Preparing the Cables for a 1600 W DC Power Supply*

You will need two cable wires for each installed DC power supply: one DC power input cable, which is provided, and a grounding cable. We recommend that each cable have differently colored insulation, as described in [Required Tools and Materials for Installing a 1600 W DC Power Supply](#) on page 49.

To prepare the cable wires, follow these steps:

1. If necessary, on each cable wire, strip 6 mm (0.25 inch) of insulation from one end.

2. Repeat step 1 for the other cable wire.

### Installing a 1600 W DC Power Supply

Before installing a 1600 W DC power supply (part no. XN-DCPWR-1600W-F):

- Verify that the airflow direction for the power supply is the same as the airflow direction of the installed fan modules in the switch.

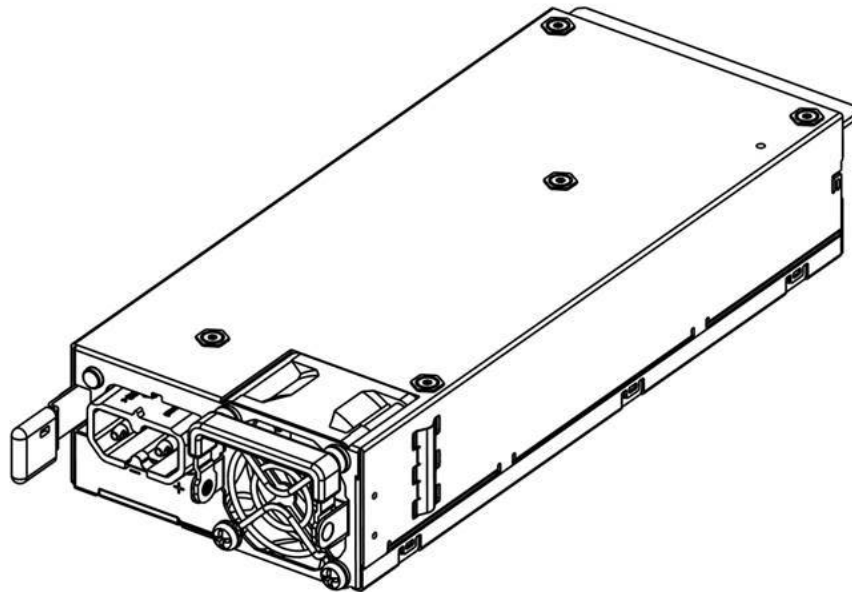
To install the power supply, follow these steps:



#### Caution

The handle on the power supply is not designed to be used to lift or carry the power supply or the switch to which it is attached.

1. Attach an ESD-preventive wrist strap to your bare wrist and connect the metal end to an appropriate ground point on the rack.
2. If necessary, remove a blank panel from the rear of the switch.
3. Verify that the power supply is right side up (label on the bottom).



4. Carefully slide the power supply all the way into the power supply bay.
5. Push the power supply in until the latch snaps into place.



#### Caution

Do not slam the power supply into the switch.

6. To install a second power supply, repeat the procedure.

When you are finished, connect the ground wire to each power supply. See [Connecting the Ground Wire to a 1600 W DC Power Supply](#) on page 51.

### Connecting the Ground Wire to a 1600 W DC Power Supply

Follow these steps to connect the ground wire to a 1600 W DC power supply.



#### Warning

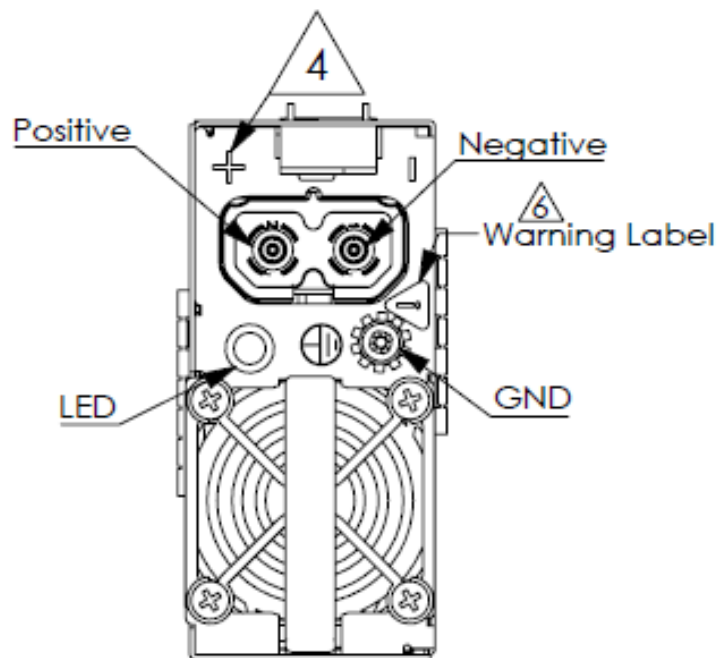
Be sure to connect the chassis ground wire before you connect any power cables.




#### Warning

Be sure to disconnect the ground wire after you disconnect all power cables.

1. Verify that the DC circuit is de-energized.
2. Attach an ESD-preventive wrist strap to your bare wrist and connect metal end to an appropriate ground point on the rack.
3. Connect the ground wire to the grounding point on the power supply, labeled GND in the following figure:



**Figure 24: Front view of 1600 W DC PSU**

Directly beneath the grounding point, you will see the international symbol for earth ground –  – on the body of the switch.

- a. Attach mm ring lug to the 6 AWG ground wire.
- b. Secure the ring lug with a 5mm hex socket and tighten.
- c. Gently tug the ground wire to make sure it is fastened securely.
4. Connect the other end of the wire to a known reliable earth ground point at your site.

When you have connected the ground wire, connect the power supply to the power source using the provided DC power input cable. Follow the instructions in [Connecting a 1600 W DC Power Supply to the Source Voltage](#) on page 52.

#### *Connecting a 1600 W DC Power Supply to the Source Voltage*

One 1600 W DC power supply is available: model XN-DCPWR-1600W-F (front-to-back airflow). It can connect to a -48 V power source.

The DC power connection at your facility must be made by a qualified electrician, following these instructions.



#### **Warning**

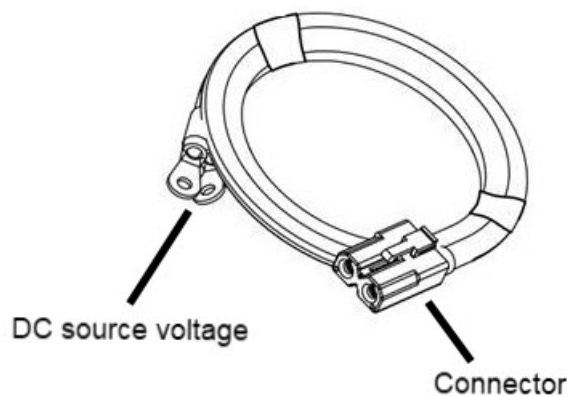
Always make sure that the DC circuit is de-energized before connecting or disconnecting the DC power cables on the DC power supply.



#### **Caution**

Provide proper connection and strain relief on the DC power cables in accordance with all local and national electrical codes.

1. Verify that the DC circuit is de-energized.
2. Attach an ESD-preventive wrist strap to your bare wrist and connect the metal end to an appropriate ground point on the rack.
3. Plug the connector that contains the **negative** (V+DC) and **positive** (V-DC) wires to the power supply.



4. Connect the cables to the DC source voltage, using hardware appropriate to the installation site and following local and national electrical codes.

Power up to the switch, following the steps in [Powering up the Device](#) on page 52.

Leave the ESD strap permanently connected to the rack, so that the strap is always available when you need to handle ESD-sensitive components.

## Powering up the Device

An AC power cord is not included with the AC power supply. You can purchase AC power cords for use in the US and Canada from Extreme networks or from your local

supplier. The cord must meet the requirements listed in [Power Cord Requirements for AC-Powered Switches and AC Power Supplies](#) on page 91

To power up an Extreme Networks device, do the following.

1. For devices that are connected to AC power, connect the power cord to the AC power input socket on the switch (or power supply) and to an AC power outlet.
2. For devices that are connected to DC power, do the following:
  - a. Verify that the DC circuit is de-energized.
  - b. Verify that the ground wire is connected to the grounding lug on the rear of the device.

The grounding lug is identified by the international symbol for earth ground:



- c. Verify that the DC power input cables are properly connected to the DC power supplies at the rear of the device.
  - d. Energize the circuit.
3. When power is connected, verify that the PSU LED turns green.

When the PSU LED has turned green, follow the instructions in [Connecting Network Interface Cables](#) on page 53.

If the PSU and RPS LEDs do not turn green, refer to the *LEDs* topic for your device model (in [Monitoring Overview](#) on page 64) for troubleshooting information.

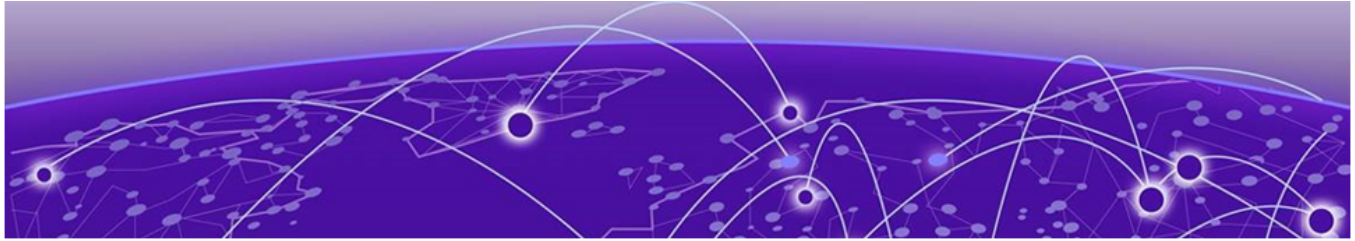
## Connecting Network Interface Cables

Use the appropriate type of cable to connect the ports of your switch to another switch or router.

Cable Type	Maximum Distance
CAT5E	55 meters
CAT6	55 meters
CAT6A	100 meters

Working carefully, one port at a time, do the following:

1. Verify that you have identified the correct cable for the port.
2. Use an alcohol wipe or other appropriate cleaning agent to clean the cable connectors; make sure they are free of dust, oil, and other contaminants.
3. If you are using optical fiber cable, align the transmit (Tx) and receive (Rx) connectors with the correct corresponding connectors on the switch or the I/O module.
4. Press the cable connectors into their mating connectors on the switch or I/O module until the cable connector is firmly seated.
5. Repeat step 1 through step 5 for the remaining cables on this or other switches or I/O modules.
6. Dress and secure the cable bundle to provide appropriate strain relief and protection against bends and kinks.



# Activating and Verifying the Switch

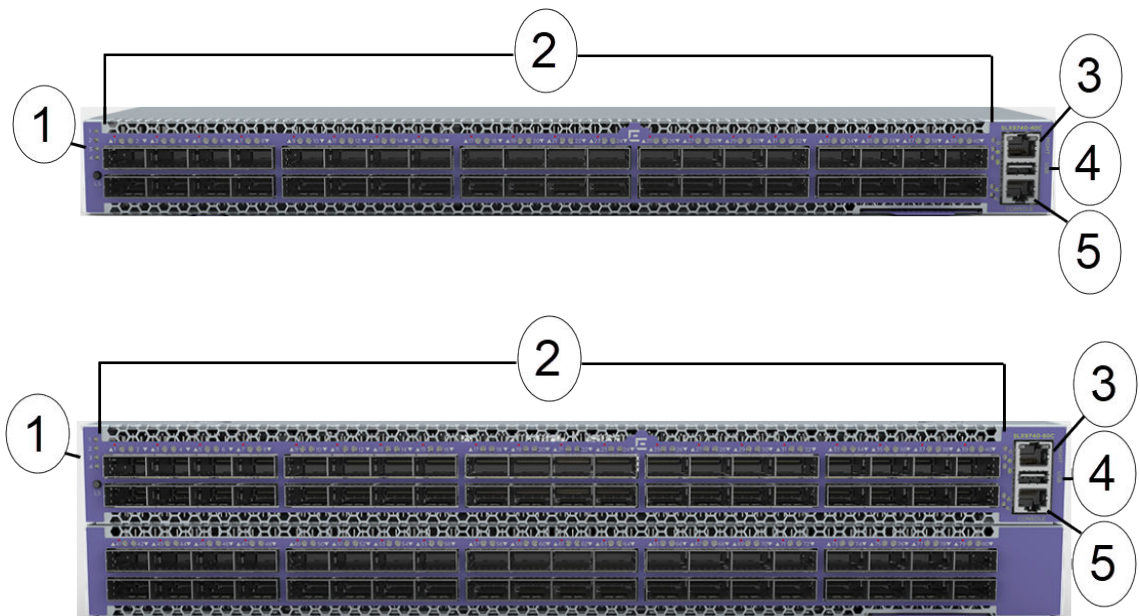
[Establishing a serial connection](#) on page 54

[Configuring the Switch for Use](#) on page 56

## Establishing a serial connection

To establish a serial connection to the console port on the device, complete the following steps.

1. Verify that the device is powered on by verifying that all power LED indicators on the management and interface ports, power supply and fan modules display a steady green light.
2. Connect the RJ-45 serial cable provided with the device to the console port of the device. Shown below are the Port-side views of both SLX 9740 Switch models:



**Figure 25: Port-side view of the SLX 9740 Switches**

1 = LEDs	4 = USB port
2 = 100GE/40GE QSFP28 ports	5 = Console port

3 = Management port



**Note**

The console or serial port is intended primarily for the initial setting of the IP address.

3. Access the device using a terminal emulator application (such as HyperTerminal in a Windows environment or Tip in a LINUX environment).
4. Disable any serial communication programs running on the workstation (such as synchronization programs).
5. Open a terminal emulator application (such as HyperTerminal on a PC, or TERM, Tip, or Kermit in a LINUX environment), and configure the application as follows:
  - In a Windows environment:

Parameter	Value
Bits per second	115200
Data bits	8
Parity	None
Stop bits	1
Flow control	None



**Note**

Flow control is not supported on the serial consoles when attached to remote terminal servers and must be disabled to ensure proper operation.

- In a LINUX environment, enter the following string at the prompt:

```
tip /dev/ttyb -115200
```

If ttyb is already in use, use ttya instead and enter the following string at the prompt:

```
tip /dev/ttya -115200
```

When the terminal emulator application stops reporting information, press **Enter**. You receive the following login prompt:

```
SLX login:
```

6. Follow the steps to log into the switch and initial configuration steps in [Configuring the Switch for Use](#) on page 56.

## Configuring the Switch for Use

---

To perform the initial login and complete the initial configuration tasks, follow these steps from the management console.

1. Log in to the console using *admin* as the default login name and *password* as the default password.

As login to the device occurs, you are prompted to change the device passwords.

```
Please change passwords for switch default accounts now.  
Use Control-C to exit or press 'Enter' key to proceed.
```

2. Press **Enter** to step through a procedure to change the passwords as shown in the following example. To skip modifying the password, press **Ctrl+C**.

```
Warning: Access to the Root and Factory accounts may be  
required for proper support of the switch. Please ensure the Root  
and Factory passwords are documented in a secure location. Recovery of  
a lost Root or Factory password will result in fabric downtime.  
  
for user - admin  
Changing password for admin  
Enter old password:  
Enter new password:  
Re-type new password:  
passwd: all authentication tokens updated successfully
```

Passwords can be 8 through 40 characters long. They must begin with an alphabetic character. They can include numeric characters, the period (.), and the underscore (\_) only. Passwords are case-sensitive, and they are not displayed when you enter them on the command line. For more information on passwords, refer to *Extreme SLX-OS Security Configuration Guide* for the SLX 9740 device.

The switch is ready for use.

To configure other switch features, see *Extreme SLX-OS Layer 2 Switching Configuration Guide*.





# Transceivers and Cables

---

- [Supported transceivers and cables](#) on page 57
- [Time and items required](#) on page 57
- [Precautions specific to transceivers and cables](#) on page 58
- [Cleaning the fiber-optic connectors](#) on page 58
- [Managing cables](#) on page 59
- [Installing a QSFP28 transceiver](#) on page 59
- [Replacing a QSFP28 transceiver](#) on page 61
- [Breakout cables](#) on page 62
- [Verifying transceiver operation](#) on page 63

## Supported transceivers and cables

---

SLX 9740 switch routers require QSFP28 optics for 100GbE connectivity, and 40GbE-to-10GbE breakouts for 10GbE connectivity.

For current information about transceivers and cables that is supported by this device, refer to *Extreme Ethernet Optics Family Datasheet* on <https://cloud.kapostcontent.net/pub/a070d154-d6f1-400b-b2f0-3d039ae2f604/data-center-ethernet-optics-data-sheet> and to the current *SLX-OS20.2.1 for ExtremeRouting SLX 9740 Release Notes*.

## Time and items required

---

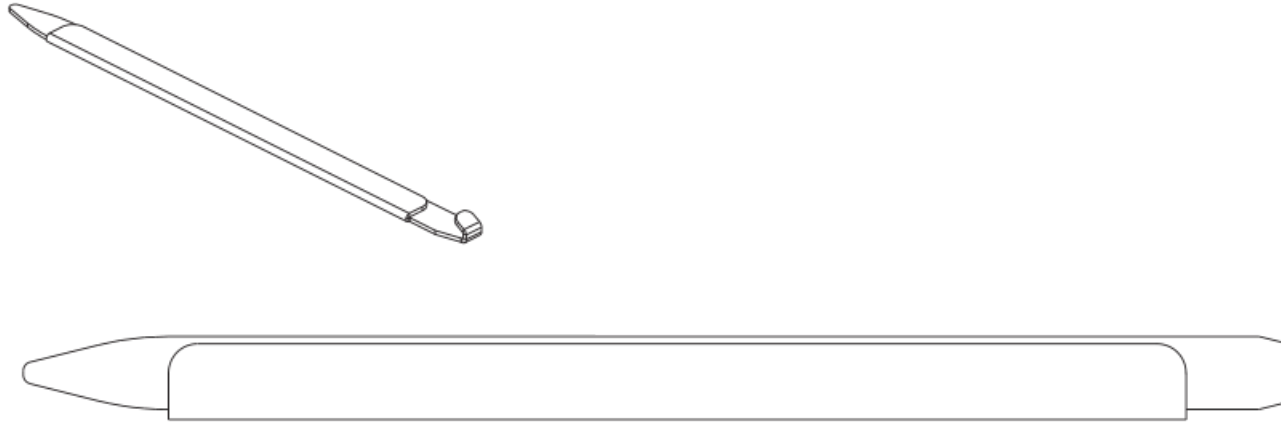
The installation or replacement procedure for one transceiver takes less than 5 minutes. Ensure that the following items are available:

- Required number of compatible power cables
- Required number of supported Extreme-branded transceivers
- Required number of compatible fiber-optic cables
- Optical transceiver extraction tool (for 10 Gbps transceiver only)



### Note

Most Extreme devices come with a transceiver extraction tool and holster. The extraction tool is designed to remove transceivers from modules where the space is limited.



**Figure 26: Optical transceiver extraction tool**

## Precautions specific to transceivers and cables

---



**Warning**

All fiber-optic interfaces use Class 1 lasers.



**Warning**

Use only optical transceivers that are qualified by Extreme Networks, Inc. and comply with the FDA Class 1 radiation performance requirements defined in 21 CFR Subchapter I, and with IEC 60825 and EN60825. Optical products that do not comply with these standards might emit light that is hazardous to the eyes.



**Caution**

Do not use the port cover tabs to lift the module. They are not designed to support the weight of the module, which can fall and be damaged.



**Caution**

Before plugging a cable into any port, be sure to discharge the voltage stored on the cable by touching the electrical contacts to ground surface.

## Cleaning the fiber-optic connectors

---

To avoid problems with the connection between the fiber-optic transceiver (SFP+, QSFP, or QSFP28) and the fiber cable connectors, Extreme strongly recommends cleaning both connectors each time you disconnect and reconnect them. Dust can accumulate on the connectors and cause problems such as reducing the optic launch power.

To clean the fiber cable connectors, Extreme recommends using a fiber-optic reel-type cleaner. When not using an SFP+ or QSFP connector, make sure to keep the protective covering in place.

## Managing cables

---

The minimum radius that a 50 micron cable can be bent under full tensile load is 5.1 cm (2 in.). For a cable under no tensile load, that minimum is 3.0 cm (1.2 in.). Cables can be organized and managed in a variety of ways, for example, using cable channels on the sides of the rack or patch panels to minimize cable management. Following is a list of additional recommendations:

- Plan for rack space required for cable management before installing the device.
- Leave at least 1 m (3.28 ft) of slack for each port cable. This provides room to remove and replace the device, allows for inadvertent movement of the rack, and helps prevent the cables from being bent to less than the minimum bend radius.
- For easier maintenance, label the fiber-optic cables and record the devices to which they are connected.
- Keep LEDs visible by routing port cables and other cables away from the LEDs.
- Do not route the cables in front of air vents.
- Use Velcro ® type straps to secure and organize fiber-optic cables.
- Route the cables away from LEDs to keep them visible.
- Use the cable management comb that attaches to the chassis for simple cable management. The comb can be installed without service disruption.

**Caution**

Before plugging a cable into any port, be sure to discharge the voltage stored on the cable by touching the electrical contacts to ground surface.

**Note**

Do not use tie wraps with optical cables because they are easily overtightened and can damage the optic fibers.

## Installing a QSFP28 transceiver

---

While non-Extreme optics are supported, Extreme-qualified transceivers are recommended. The port might not become operational or it may have a higher error rate using unqualified transceivers.

The following additional notes apply to the QSFP28 transceivers:

- While non-Extreme optics are supported, Extreme-qualified transceivers are recommended.  
If using 40GbE-to-10GbE breakouts, each QSFP28 transceiver contains four individual 10 GbE ports. Be aware that any problems with one port could affect all four ports in the quad if the QSFP28 must be replaced.
- Some QSFP28 transceivers have an integrated cable attached. You do not need to install a separate cable.

To insert an QSFP28 transceiver and cable, complete the following steps.

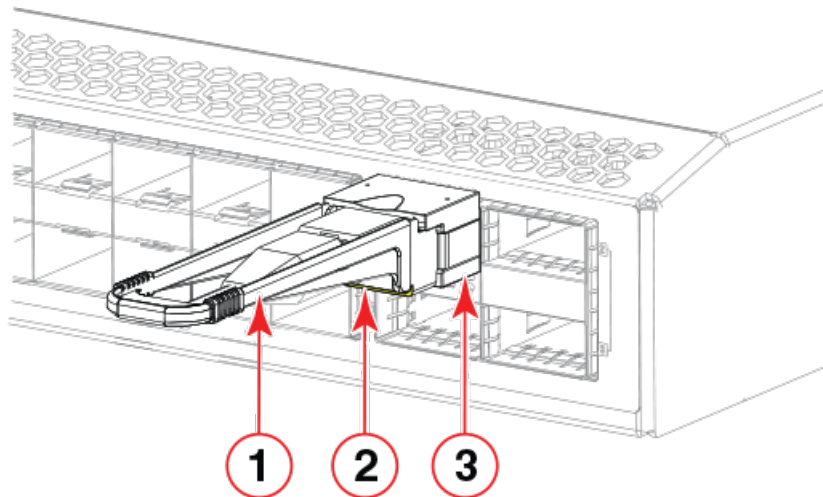
1. Push the transceiver into the port using the pull tab. Transceivers are keyed so that they can only be inserted with the correct orientation. If a transceiver does not slide

in easily, ensure that it is correctly oriented. Push the correctly oriented transceiver into the port until it is firmly seated and the latching mechanism clicks.



**Note**

Always use the transceiver pull tab to insert or remove the QSFP28 transceivers, as the transceiver might be hot.



- a. Pull tab
- b. QSFP28 cable
- c. QSFP28 transceiver

**Figure 27: Installing a QSFP28 transceiver into the interface module port**

After insertion, the LEDs have the following status:

- Off - no link
  - On - link, no traffic
  - Rapid flash - link with traffic
  - Slow flash (one second on, one second off) - beaconing feature
2. Position the cable so that the key (the ridge on one side of the cable connector) is aligned with the slot in the transceiver. Insert the cable into the transceiver until the latching mechanism clicks.



**Note**

If your transceiver has an integrated cable, you do not need to install a cable.



**Note**

Cables are keyed so that they can be inserted in only one way. If a cable does not slide in easily, ensure that it is correctly oriented. Do not insert any unsupported cable intended for another type of transceiver into a regular QSFP28 transceiver. You may damage the cable as well as the transceiver.

3. Organize cables to avoid covering LEDs and air vents so that LCs can be removed. Refer to [Managing cables](#) on page 59 for more information.

## Replacing a QSFP28 transceiver

Complete the following steps to remove and then install a new QSFP28 transceiver.

1. Remove any cables that are inserted into the transceiver.

**Note**

If your transceiver has an integrated cable, you cannot remove the cable.

2. Grasp the transceiver pull tab and gently pull the transceiver straight out from the port.

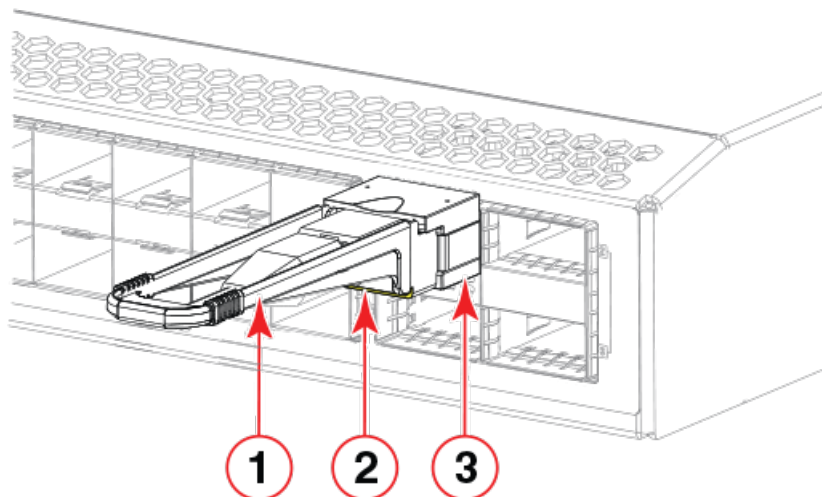
**Note**

Grasp the pull tab near the body of the transceiver to reduce the chances of bending the pull tab. As the transceiver may be hot, always use the pull tab and avoid touching the transceiver body.

3. To insert the replacement transceiver, use the pull tab to carefully push the transceiver into the port. Transceivers are keyed so that they can only be inserted with the correct orientation. If a transceiver does not slide in easily, ensure that it is correctly oriented. Gently push the correctly oriented QSFP28 transceiver until the latching mechanism clicks.

**Note**

The following figure uses a generic interface module. Your interface module might look different.



- a. Pull tab
- b. QSFP28 cable connector
- c. QSFP28 transceiver

**Figure 28: Replacing a QSFP28 optical transceiver into blade port**

- Position a cable so that the key (the ridge on one side of the cable connector) is aligned with the slot in the transceiver. Insert the cable into the transceiver until the latching mechanism clicks.

**Note**

If your transceiver has an integrated cable attached, you will not install a cable.

When both ends of the cable are inserted and the link is fully established, the LED displays steady green.

**Note**

Cables are keyed so that they can be inserted in only one way. If a cable does not slide in easily, ensure that it is correctly oriented.

- Organize cables to avoid covering LEDs and air vents. Refer to [Managing cables](#) on page 59 for more information.

## Breakout cables

The copper breakout cables are terminated with optical connectors and are available in 1m, 3m, 5m, and greater lengths. No additional connectors or cabling are required when using the copper breakout. When using the fiber breakout cables, additional 10Gb optics are required.

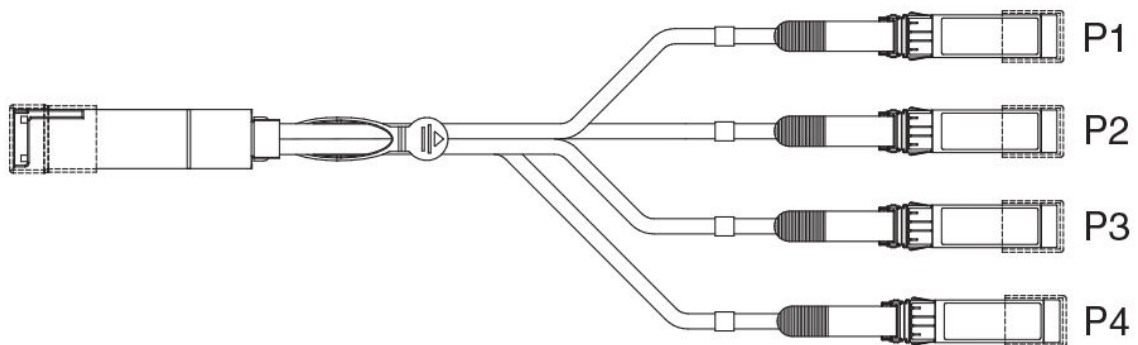
For the SLX 9740 switch router interfaces 0/25 to 0/36 support up to 48 10GbE or 48 25GbE ports in breakout mode by using the following optics:

For 4 x 10GbE breakout:

- 4 SFP+ 40GbE-to-10GbE copper breakout cables in 1m, 3m, or 5m or greater lengths.
- 40G-QSFP-SR4-INT (with fiber breakout cables and additional 10GbE optics).
- 40G-QSFP-ESR4 (with fiber breakout cables and additional 10GbE optics).

For 4x 25GbE breakout:

- 100G-QSFP-4SFP-P-XXX



**Figure 29: QSFP+ to 4 SFP+ (4 x 10 GbE) direct-attach copper breakout cable**

## Verifying transceiver operation

---

To verify operation of a transceiver, view the LEDs on the transceiver. To find the LED locations on the interface modules, refer to [LED activity interpretation](#) on page 64. After you have connected and configured the ports for Ethernet connectivity and connected the cable to another active port, the LED becomes solid green. When traffic is detected on the port, the light becomes blinking green.

You can also enter the **show interface status** and **show ip interface brief** commands to verify proper transceiver operation.



# Monitoring the Device

---

- [Monitoring Overview](#) on page 64
- [LED activity interpretation](#) on page 64
- [LED indicators](#) on page 65
- [RJ-45 Management Port LEDs](#) on page 66
- [QSFP28 Port LEDs](#) on page 67
- [1600 W AC Power Supply LEDs](#) on page 69
- [1600 W DC Power Supply LEDs](#) on page 69

## Monitoring Overview

---

The Extreme device is engineered for reliability and requires no routine operational steps or maintenance. You can monitor the device by paying attention to the following information:

- The LEDs showing the status of system components
- A description of the operations that the device performs when you power it on

The following commands can be especially helpful in monitoring the health status of various device components. For details about these commands, refer to *Extreme SLX-OS Monitoring Configuration Guide* for the SLX 9740 device.

- **show chassis**
- **show system**
- **show slots**
- **show linecard**
- **show environment fan**
- **show environment power**
- **show environment sensor**
- **show environment temp**

## LED activity interpretation

---

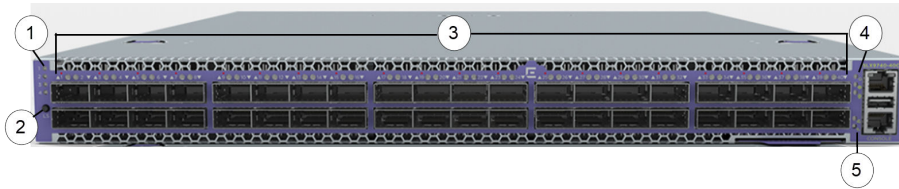
The SLX 9740 switch router has the following LEDs on the front panel:

- One power single-color status LED (green)
- One status bicolor status LED (green and amber)



- One fan bicolor status LED (green and amber)
- One PSU bicolor status LED (green and amber)

The figure below shows the LEDs on the SLX 9740 switch router front panel.



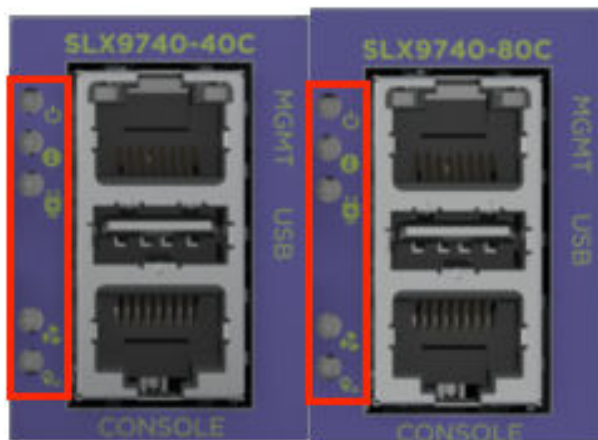
**Figure 30: SLX 9740 switch router LEDs**

1 = Power LED	2 = Locator LED
3 = Status Port LEDs	4 = Management port LEDs
5 = Console port LEDs	

## LED indicators

The SLX 9740 switch router LED indicators are as follows:

- The Power/Status LEDs are visible to the front panel
- The Ethernet LEDs are integrated with the RJ45 connector
- The Power supply LEDs are integrated with the PSU
- The 10G and 100G Port LEDs are surface mount types. They are visible to the front panel



**Figure 31: SLX 9740 System LEDs**

The following table shows the LED indications on the SLX 9740 switch router:

**Table 12: SLX 9740 device LED Indications**

LED Function/state	Meaning	Possible cause
<b><i>Power</i></b>		
Off	No power	Some Power rails are dropping below specification
Green	Valid power. All monitored voltages are nominal	
<b><i>Status (bicolor)</i></b>		
Blinking Amber-Green	Attention	TBD by SW
Amber	Fault/ initial state	This LED shall be lit during the reboot
Green	Board is operational	
<b><i>Power Supply Output Status (On PSU)</i></b>		
Off	No Power	
Green Blinking	Stand-By	Standby output enabled with no power supply warning or fault detected
Green Steady	Power GOOD	Main output and standby output enabled with no power supply warning or fault detected
Amber Blinking	Warning	Power supply warning detected as per PMBus STATUS_X reporting bytes
Amber Steady	FAULT	Power supply fault detected as per PMBus STATUS_X reporting bytes
<b><i>Fan Status LED (On Fan FRU)</i></b>		
Off (no light)	No Power	
Green Steady	Fan operates per specification (Normal)	
Amber Steady	Fan needs attention/ replacement	

## RJ-45 Management Port LEDs

The 1 Gb RJ-45 Management port includes two LEDs that are both amber and green. The LEDs are located on each side of the RJ-45 port. The LED on the left side is labeled Speed and the LED on the right side is labeled Link/Activity. The SLX 9740 models include one management port on the front panel. The following table describes the meaning of the colors and states for the LEDs.



**Figure 32: RJ45 Management Port LEDs**

**Table 13: 10/100/1000Base-T RJ-45 Management Port LEDs**

LED	Color/State	Description
Speed	Off	The port is operating at 10 Mbps.
	Amber	The port is operating at 1 Gbps.
	Green	The port is operating at 100 Mbps.
Link/Activity	Off	No link.
	Green	The port has established a link. There is no data activity.
	Blinking green	The port has established a link and there is data activity.

## QSFP28 Port LEDs

Each port has one LED to indicate channel status. A channel selector switch enables you to display the status of individual channels. The selected channel is indicated in the display. The following table describes the states for the LED.



QSFP28 Channel	Description
0 (Default) - Port and all channels/lanes	(Default) Indicate the state of the port (all 4 lanes)
1	Indicates the link state and speed on Lane 1
2	Indicates the link state and speed on Lane 2
3	Indicates the link state and speed on Lane 3
4	Indicates the link state and speed on Lane 4

The port/channel LED indications are listed below.



LED	State	Description
Link/Activity	Off	No link or fault. Port is either administratively disabled or enabled but no transceiver is installed
	White (solid)	Link at 100G
	White (fast blinking)	Activity at 100G
	Yellow (solid)	Link at 50G
	Yellow (fast blinking)	Activity at 50G
	Blue (solid)	Link at 40G
	Blue (fast blinking)	Activity at 40G
	Amber (solid)	Link at 25G
	Amber (fast blinking)	Activity at 25G
	Green (solid)	Link at 10G
	Green (fast blinking)	Activity at 10G
	Red (solid)	Fault detected

## 1600 W AC Power Supply LEDs

The following tables describe the meanings of the LEDs on the 1600 W AC power supply (part number XN-ACPWR-1600W-F or XN-ACPWR-1600W-R).

The LEDs are located on the end of the power supply unit, arranged vertically to the left of the power cord receptacle.

**Table 14: 1600 W AC Power Supply LED Status Indications**

Label and Color	Description	State	Meaning
! Amber	Fault Indicator	On (Solid)	PSU fault
		Off	No PSU fault
DC (Green)	DC output Good	On (solid)	DC output OK
		Off or Blinking	DC output fail
AC (Green)	AC input Good	On	AC input OK
		Off	AC input fail

## 1600 W DC Power Supply LEDs

The following tables describe the meanings of the LEDs on the 1600 W DC power supply (part number XN-DCPWR-1600W-F).

The LEDs are located on the end of the power supply unit, arranged vertically to the left of the terminal block.

**Table 15: 1600 W DC Power Supply LED Status Indications**

Label and Color	Description	State	Meaning
! Amber	Fault Indicator	On (Solid)	PSU fault
		Off	No PSU fault
OUT OK (Green)	DC output Good	On (solid)	DC output OK
		Off or Blinking	DC output fail
IN OK (Green)	DC input Good "IN OK"	On	DC input OK
		Off	DC input fail



# Removing and Replacing Components

---

[Replacing Internal Power Supplies](#) on page 70

[Removing the Device from the Rack](#) on page 70

## Replacing Internal Power Supplies

---

You can replace internal power supplies as needed while the switch is operating ("hot swapping").

All installed power supplies must have the same airflow direction (front-to-back or back-to-front) and must also match the airflow direction of the fan modules.

To replace one or both AC internal power supplies in an SLX 9740 switch, follow the steps in [Installing a 1600 W Internal AC Power Supply](#) on page 46.

To replace one or both DC internal power supplies in an SLX 9740 switch, follow the steps in [Installing a 1600 W Internal DC Power Supply](#) on page 49.

## Removing the Device from the Rack

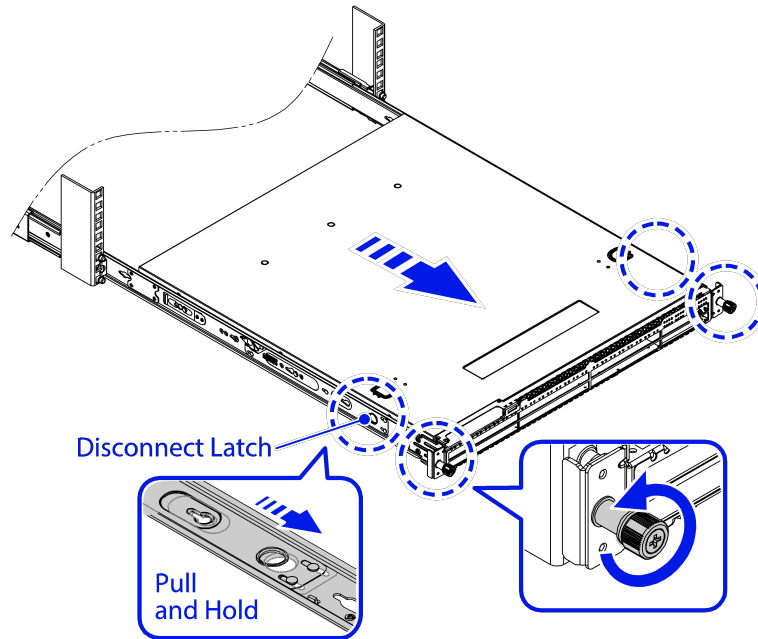
---

To remove or reposition a device after you have mounted it in a rack, follow these steps.

These procedures assume that you have attached the device to the rack as described in one of the following topics:

- [Attaching the Device to a Four-Post Rack](#) on page 33
  - [Attaching the Device to a Two-Post Rack](#) on page 39
1. Disconnect the device from its power source or sources.
  2. Remove all cables and transceivers.

3. To remove a device from a four-post rack, do the following:
  - a. Push the disconnect latch to release the device after it is fully extended.

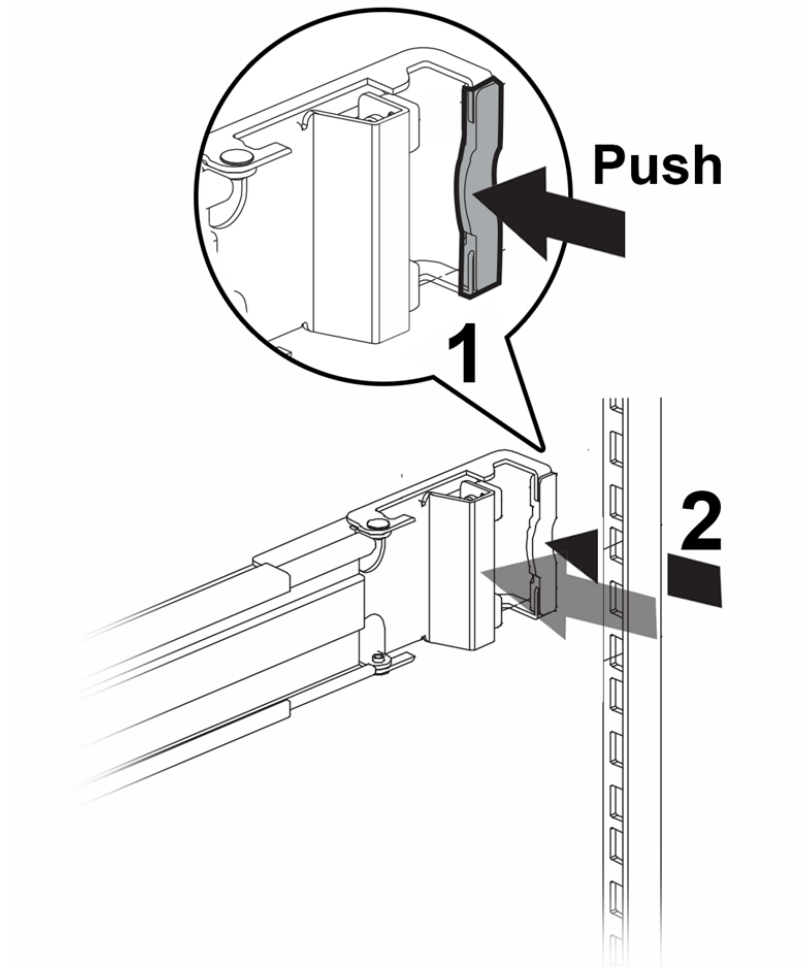


**Figure 33: Disconnect latch for removal**

- b. Disengage the retainers that are connecting the mounting brackets with the sliding rails on both sides.
    - c. Carefully slide the device out of the slider assembly and place it on a flat surface. You can leave the slider assemblies in place. If you want to remove them, continue with the next step.

- d. On one of the slider assemblies, push the rear clamp until it separates from the rear rack post.

See the diagram below - *Removing the Slider Assembly: Rear Rack Post*.

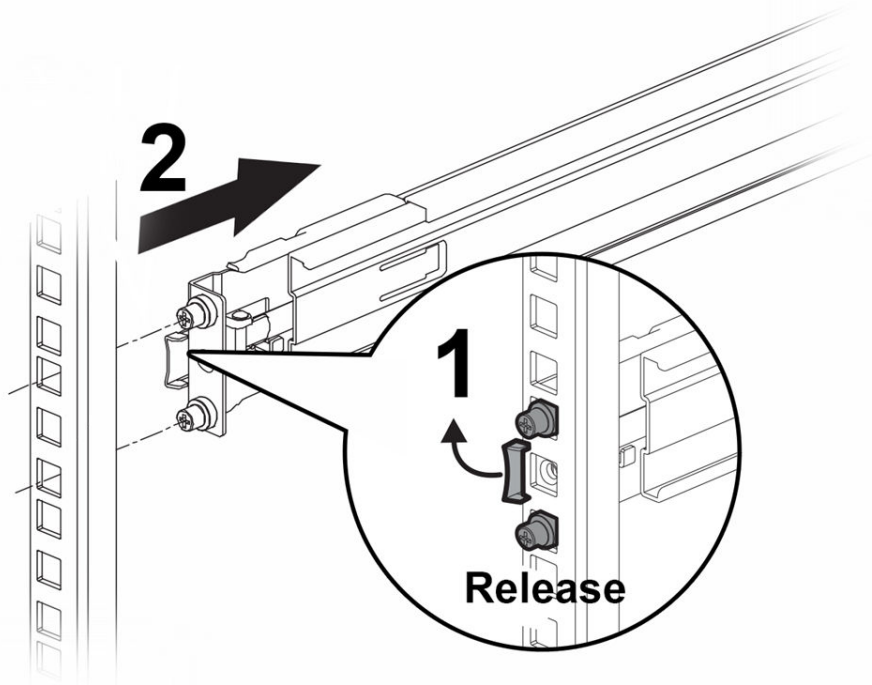


**Figure 34: Removing the Slider Assembly: Rear Rack Post**



- e. Release the tab that holds the front of the slider assembly to the front rack post, and pull the pegs out.

See the diagram below - *Removing the Slider Assembly: Front Rack Post*.



**Figure 35: Removing the Slider Assembly: Front Rack Post**

- f. Repeat steps "d" and step "e" to remove the second slider assembly.
4. To remove a device from a two-post rack, do the following:
    - a. Carefully supporting the weight of the device, unscrew the mounting brackets from the rack.
    - b. Tilt the device so that the brackets are clear of the rack posts, and carefully lift it out of the rack.

If the device cannot be tilted (because other equipment is mounted directly above and below), remove one or two mounting brackets from the device and then slide the device out.

If you plan to use the device again later, we recommend storing it with the mounting brackets attached.



# Fan Assemblies

---

- [Fan assembly overview](#) on page 74
- [Precautions specific to fan assemblies](#) on page 75
- [Identifying the airflow direction](#) on page 76
- [Replacing Fan Modules](#) on page 77
- [Changing Airflow Direction](#) on page 78

## Fan assembly overview

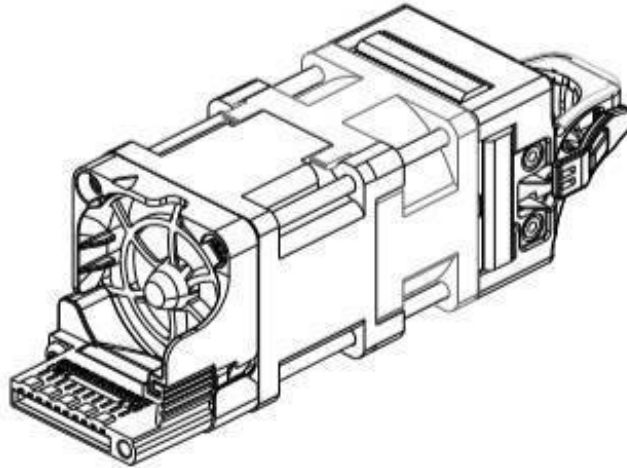
---

The ExtremeRouting SLX 9740 switch router includes four to six redundant, hot-swappable fan units.

The fan assemblies in the SLX 9740 switch router chassis can be removed and replaced without special tools. The device can continue operating during the replacement.

The device supports the following types of fan assemblies:

- Fan assembly with nonport-side air exhaust. This unit moves the air from the port-side to the nonport-side of the device.
- Fan assembly supply with nonport-side air intake. This unit moves the air from the nonport-side to the port-side of the device.



**Figure 36: Fan assembly**

## Precautions specific to fan assemblies



### Warning

Be careful not to accidentally insert your fingers into the fan tray while removing it from the chassis. The fan may still be spinning at a high speed.



### Caution

Disassembling any part of the power supply and fan assembly voids the warranty and regulatory certifications. There are no user-serviceable parts inside the power supply and fan assembly.



### Caution

Ensure that the airflow direction of the power supply unit matches that of the installed fan tray. The power supplies and fan trays are clearly labeled with either a green arrow with an "E", or an orange arrow with an "I."




### Caution

If you do not install a module or a power supply in a slot, you must keep the slot filler panel in place. If you run the chassis with an uncovered slot, the system will overheat.


## Identifying the airflow direction

The power supply and fan assemblies are identified by the following airflow directions:

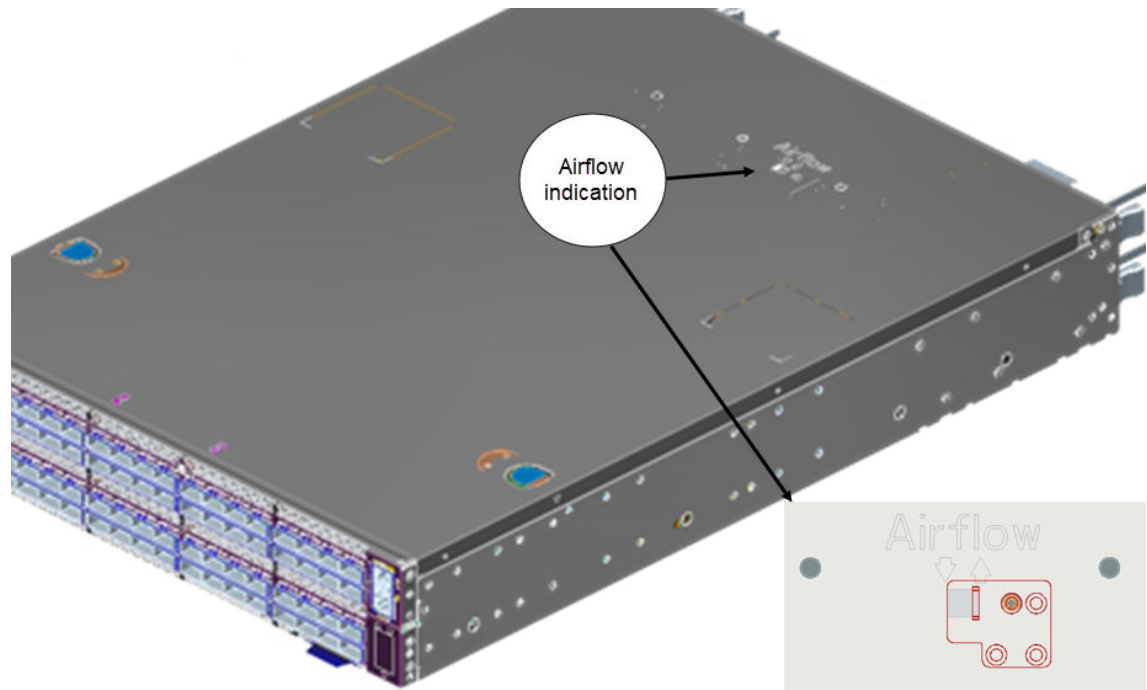
- **Intake power supply and fan assembly with an orange "I" label or without any label:** Pulls air from the nonport-side of the switch and exhausts it out the port side.

	<ul style="list-style-type: none"> <li>◦ Nonport-side air intake</li> <li>◦ Port-side air exhaust</li> <li>◦ Back-to-front (nonport-side to port-side) airflow</li> <li>◦ Part numbers ending with -R</li> </ul>
---	--

- **Exhaust power supply and fan assembly with a green "E" label:** Pulls air from the port side of the switch and exhausts it out the nonport-side.

	<ul style="list-style-type: none"> <li>◦ Nonport-side air exhaust</li> <li>◦ Port-side air intake</li> <li>◦ Front-to-back (port-side to nonport-side) airflow</li> <li>◦ Part numbers ending with -F</li> </ul>
---	--

- You can check the top view of the switch to ensure proper groove alignment:



**Figure 37: Airflow groove alignment (front-to-back shown)**

## Replacing Fan Modules

---

Before you begin, have the replacement fan module on hand so that you can complete the replacement promptly. The switch can overheat if left without adequate cooling for an extended time.

You can replace fan modules as needed while the switch is operating ("hot swapping").

All installed fan modules must blow air in the same direction and must match the airflow direction of the installed power supplies.

- If the switch's fan tray has a **blue** tab, the airflow is front-to-back. Use a fan module labeled **Air Out**.
- If the switch's fan tray has a **green** tab, the airflow is back-to-front. Use a fan module labeled **Air In**.



### Note

The operating-system software cannot display the airflow direction.

1. Gently pull the tab (labeled **Air Out** or **Air In**) on the end of the fan module.  
The fan module is held in place by spring clips. As you pull, the clips will disengage and the fan will stop.
2. Slide the fan module out of the switch and set it aside.
3. Verify that the airflow direction on the replacement fan module matches that of the installed fan modules.

Fans with front-to-back airflow have red tabs and are labeled **Air Out**.

Fans with back-to-front airflow have blue tabs and are labeled **Air In**.

4. Carefully slide the replacement fan module into the switch.



### Note

Do not force the installation. If the fan assembly does not slide in easily, ensure that it is correctly oriented before continuing.

Push until the fan module snaps into place. The fan will automatically start to operate.

When a fan assembly is installed in a slot, the power LED on the fan assembly should turn on green to confirm that the fan assembly is correctly installed and running. Refer to [LED indicators](#) on page 65.

## Changing Airflow Direction

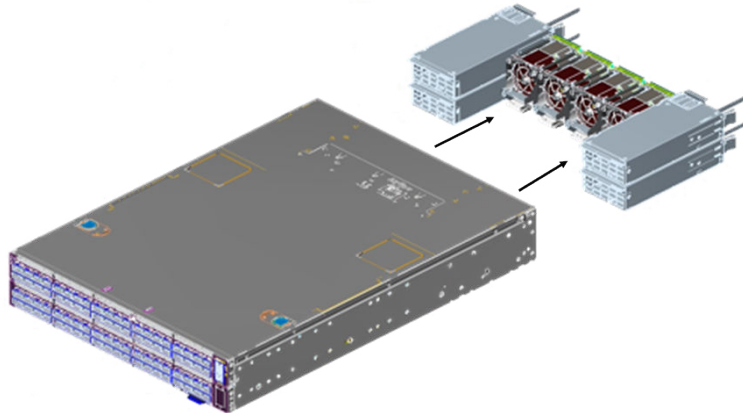
All installed fan modules must blow air in the same direction and must match the airflow direction of the installed power supplies.



### Note

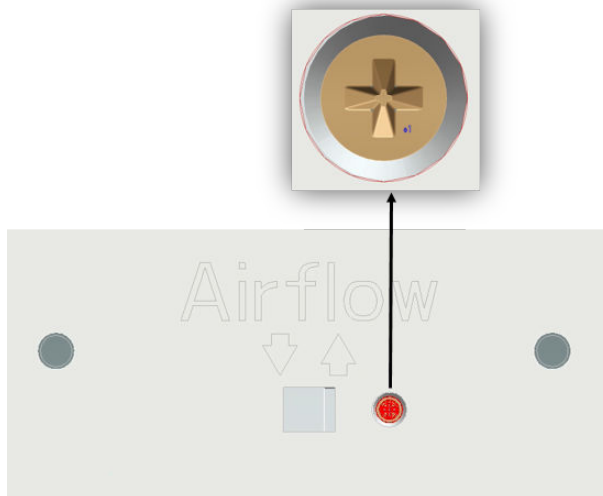
The operating-system software cannot display the airflow direction.

1. Remove the four PSUs and four fan modules by removing the two captive retaining screws and sliding all components out of the switch:



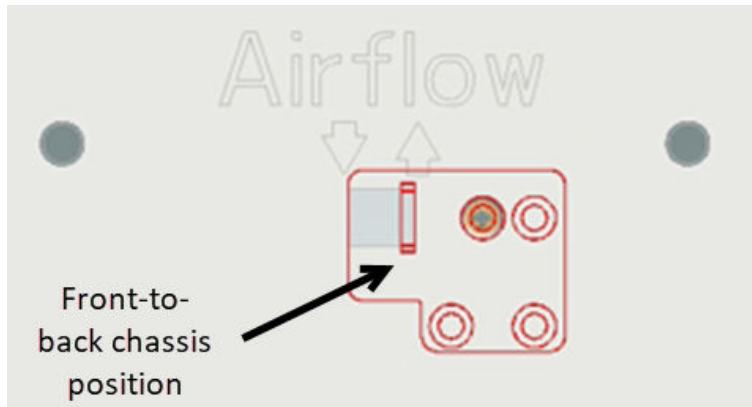
**Figure 38: Remove PSUs and fan modules**

2. Use a Phillips #1 screwdriver to loosen the chassis screw:

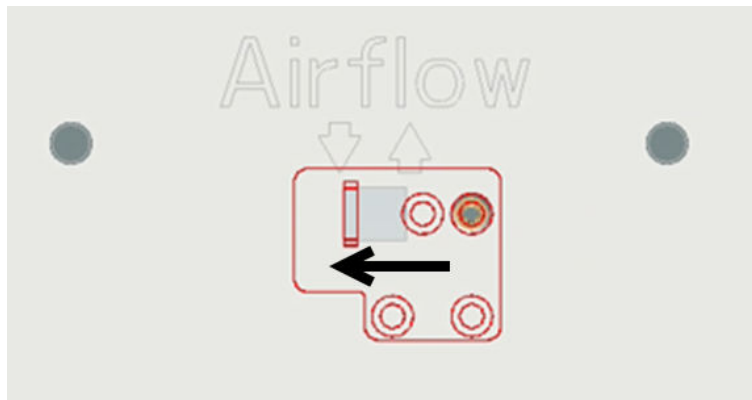


**Figure 39: Chassis switch screw front-to-back airflow**

- Use a flathead screwdriver to change the chassis switch. The following figure is an example of changing front-to-back airflow to back-to-front airflow:



**Figure 40: Front-to-back airflow chassis position**



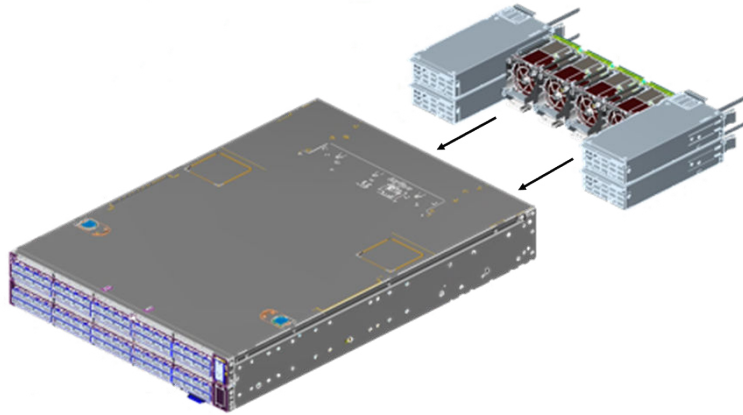
**Figure 41: Back-to-front airflow chassis position**

- Use a Phillips #1 screwdriver to tighten the chassis screw:



**Figure 42: Chassis screw back-to-front position**

5. Carefully slide the PSUs and fan modules back into the switch:



**Figure 43: Remove PSUs and fan modules**

6. Tighten the two captive retaining screws to secure the components.





# ExtremeRouting SLX 9740 Technical Specifications

[1600 W Power Supplies Technical Specifications](#) on page 89

[Power Cord Requirements for AC-Powered Switches and AC Power Supplies](#) on page 91

The ExtremeRouting SLX 9740 switch routers include the following models:

Part number	Description
SLX9740-40C, 9740-40C	SLX9740-40C, 9740-40C switch router with two unpopulated power supply slots and six unpopulated fan slots. Supports 40x100GE/40GE QSFP28 ports.
SLX9740-40C-AC-F	SLX9740-40C-AC-F switch router AC with front-to-back airflow. Supports 40x100GE/40GE QSFP28 ports with dual power supplies, six fans.
SLX9740-80C, 9740-80C	SLX9740-80C, 9740-80C switch router with four unpopulated power supply slots and four unpopulated fan slots. Supports 80x100GE/40GE QSFP28 ports.
SLX9740-80C-AC-F	SLX9740-80C-AC-F switch router AC with front-to-back airflow. Supports 80x100GE/40GE QSFP28 ports with quad power supplies, four fans.

## SLX 9740 Software Specifications

**Table 16: SLX 9740 Software Specifications**

Software Specifications	Description
Connector options	<ul style="list-style-type: none"> <li>• 40 100 GbE/40GbE ports for 9740-40C</li> <li>• 80 100 GbE/40GbE ports for 9740-80C</li> <li>• 72 (18x4) 10/25 GbE ports for 9740-40C</li> <li>• 144 (36x4) 10/25 GbE ports for 9740-80C</li> <li>• Out-of-band Ethernet management: 10/100/1000 Mbps RJ-45</li> <li>• Console management: RJ45 serial port</li> <li>• Storage: USB port, standard-A plug</li> </ul>
Maximum MAC addresses	600K (default profile) 190K (route profile)

**Table 16: SLX 9740 Software Specifications (continued)**

Software Specifications	Description
Switch fabric capacity (data rate, full duplex)	4.0 Tbps in each direction (front panel ports, 40x100Gbps) for 9740-40C 8.0 Tbps in each direction (front panel port, 80x100Gbps) for 9740-80C
Maximum VLANs	4,096
Maximum ACLs (IPv4/IPv6/L2)	2,000
Maximum members in a standard LAG	64
Maximum number of MCT switches	2
Maximum number of Bridge Domains	4096
Maximum IPv4 unicast routes	128,000
Maximum IPv6 unicast routes	10,000
Maximum IPv4 host routes	47,000
Maximum IPv6 host routes	33,000
Maximum jumbo frame size	9,216 bytes
QoS priority queues (per port)	8
IEEE Compliance	<ul style="list-style-type: none"> <li>• IEEE 802.1D Spanning Tree Protocol</li> <li>• IEEE 802.1s Multiple Spanning Tree</li> <li>• IEEE 802.1w Rapid Reconfiguration of Spanning Tree Protocol</li> <li>• IEEE 802.3 Ethernet</li> <li>• IEEE 802.3ad Link Aggregation with LACP</li> <li>• IEEE 802.3ab 1000BASE-T</li> <li>• IEEE 802.3z 1000BASE-X</li> <li>• IEEE 802.3ba / 80 2.3bm 40 GBASE-X and 100 GBASE-X</li> <li>• IEEE 802.1Q VLAN Tagging</li> <li>• IEEE 802.1p Class of Service Prioritization and Tagging</li> <li>• IEEE 802.1v VLAN Classification by Protocol and Port</li> <li>• IEEE 802.1AB Link Layer Discovery Protocol (LLDP)</li> <li>• IEEE 802.3x Flow Control (Pause Frames)</li> <li>• IEEE 802.3ae 10 GBASE-X</li> <li>• IEEE 802.3 10 GBASE-T (up to 100 m using Cat6a cabling or better)</li> <li>• IEEE 802.3bj</li> <li>• IEEE 802.3by</li> </ul>

## Weights and Physical Dimensions

**Table 17: SLX 9740 Switch Router Unpackaged Dimensions**

SLX9740-40C	Height: 4.31 cm (1.7 in) Width: 45.00 cm (17.72 in) Length (base model): 64.00 cm (25.2 in) Length (40C-AC-F model): 67.00 cm (26.38 in)
SLX9740-80C	Height: 8.66 cm (3.41 in) Width: 45.00 cm (17.72 in) Length (base model): 64.00 cm (25.2 in) Length (80C-AC-F model): 67.00 cm (26.38 in)
XN-FAN-003-F: Fan unit, front-to-back or XN-FAN-003-R: Fan Unit back-to-front	Height: 4.01 cm (1.58 in.) Width: 4.01 cm (1.58 in.) Length: 13.99 cm (5.51 in.)
XN-FAN-004-F: Fan unit, front-to-back or XN-FAN-004-R: Fan Unit back-to-front	Height: 5.99 cm (2.36 in.) Width: 4.01 cm (2.36 in.) Length: 15.49 cm (6.1 in.)
Four-post rack mount kit (included with switch)	Height: 5.00 cm (1.97 in) Width: 7.01 cm (2.76 in) Length: 72.00 cm (28.35 in)
XN-2P-RKMT299 - Two-post rack mount kit for SLX9740-40C (separately orderable)	Height: 4.2 cm (1.65 in) Width: 2.4 cm (0.93 in) Length: 12.5 cm (4.92 in)
XN-2P-RKMT300 - Two-post rack mount kit for SLX9740-80C (separately orderable)	Height: 8.99 cm (3.54 in) Width: 10.16 cm (4.00 in) Length: 13.00 cm (5.12 in)

**Table 18: SLX 9740 Switch Router Unpackaged Weight**

SLX9740-40C	10.55 kg (23.28 lb)
SLX9740-80C	20.61 kg (45.45 lb)
SLX9740-40C switch router with two AC PSUs (-F and -R models)	13.62 kg (30.04 lb)
SLX9740-80C switch router with four AC PSUs (-F and -R models)	26.48 kg (58.40 lb)
SLX9740-40C fan unit, front-to-back or back-to-front	0.12 kg (0.28 lb)
SLX9740-80C fan unit, front-to-back or back-to-front	0.31 kg (0.70 lb)
SLX9740-40C four-post rack mount kit (included with switch)	2.83 kg (6.26 lb)

**Table 18: SLX 9740 Switch Router Unpackaged Weight (continued)**

SLX9740-80C four-post rack mount kit (included with switch)	2.95 kg (6.52 lb)
XN-2P-RKMT299 - Two-post rack mount kit for SLX9740-40C (separately orderable)	0.45 kg (0.99 lb)
XN-2P-RKMT300 - Two-post rack mount kit for SLX9740-80C (separately orderable)	0.70 kg (1.54 lb)

**Table 19: SLX 9740 Switch Router Packaged Dimensions**

SLX9740-40C switch router	Height: 19.20 cm (7.56 in) Width: 59.30 cm (23.35 in) Length: 97.99 cm (38.58 in)
SLX9740-80C switch router	Height: 24.00 cm (9.45 in) Width: 59.30 cm (23.35 in) Length: 97.99 cm (38.58 in)
SLX9740-40C fan unit, front-to-back or back-to-front	Height: 6.50 cm (2.56 in) Width: 10.59 cm (4.17 in) Length: 22.60 cm (8.90 in)
SLX9740-80C fan unit, front-to-back or back-to-front	Height: 9.60 cm (3.78 in) Width: 10.31 cm (4.06 in) Length: 22.48 cm (8.46 in)
Four-post rack mount kit (included with either switch)	Height: 7.01 cm (2.76 in) Width: 10.99 cm (4.33 in) Length: 83.99 cm (33.07 in)
XN-2P-RKMT299 - Two-post rack mount kit for SLX9740-40C (separately orderable)	Height: 24.00 cm (9.45 in) Width: 20.60 cm (8.11 in) Length: 22.09 cm (8.70 in)
XN-2P-RKMT300 - Two-post rack mount kit for SLX9740-80C (separately orderable)	Height: 6.50 cm (2.56 in) Width: 10.59 cm (4.17 in) Length: 22.60 cm (8.90 in)

**Table 20: SLX 9740 Switch Router Packaged Weight**

SLX9740-40C switch router with no PSUs	17.18 kg (37.89 lb)
SLX9740-40C switch router with two AC PSUs (-F and -R models)	20.20 kg (44.59 lb)
SLX9740-80C switch router with no PSUs	29.08 kg (64.12 lb)
SLX9740-40C switch router with two AC PSUs (-F and -R models)	34.89 kg (76.94 lb)
SLX9740-40C fan unit, front-to-back or back-to-front	0.25 kg (0.56 lb)
SLX9740-80C fan unit, front-to-back or back-to-front	0.54 kg (1.21 lb)

**Table 20: SLX 9740 Switch Router Packaged Weight (continued)**

SLX9740-40C four-post rack mount kit (included with switch)	3.11 kg (6.87 lb)
SLX9740-80C four-post rack mount kit (included with switch)	3.23 kg (7.14 lb)
XN-2P-RKMT299 - Two-post rack mount kit for SLX9740-40C (separately orderable)	3.20 kg (7.05 lb)
XN-2P-RKMT300 - Two-post rack mount kit for SLX9740-80C (separately orderable)	0.82 kg (1.81 lb)

## Acoustic Specifications

**Table 21: Acoustic Specifications**

Device Model	Bystander Sound Pressure (at 27°C)	Declared Sound Power (at 27°C)
SLX9740-40C-AC-F (SLX 9740-40C with front-to-back airflow)	55 dB(A)	7.5 bels
SLX9740-40C-AC-R (SLX 9740-40C with back-to-front airflow)	59.4 dB(A)	7.9 bels
SLX9740-80C-AC-F (SLX 9740-80C with front-to-back airflow)	59.5 dB(A)	7.8 bels
SLX9740-80C-AC-R (SLX 9740-80C with back-to-front airflow)	66.7 dB(A)	8.5 bels

## Power Options

**Table 22: SLX 9740 Switch Router Power Options**

SLX 9740 Switch Router	<p><b>1600 W AC power supply:</b>  Part # XN-ACPWR-1600W-F (front-to-back):  AC Input: 100-120/200-240 VAC, 50/60 Hz  Part # XN-ACPWR-1600W-R (back-to-front):  AC Input: 200-240 VAC, 50/60 Hz  7A max. for PSU FSG059 for each PSU for SLX9740-40C  4A max. for PSU FSG059 and FSE023 for each PSU for SLX9740-40C; for SLX9740-80C, min. 2 PSUs provided.  PSU Input Socket: IEC 320 C14  Power cord input plug: IEC 320 C13</p> <p><b>1600 W DC power supply:</b>  Part # XN-DCPWR-1600W-F (front-to-back)  DC Input: +/- 48VDC 15A Max (for PSU FSK010) for each PSU for SLX9740-40c  +/- 48VDC 15A Max (for PSU FSK010) for each PSU, min. x2 for SLX9740-80C</p>
------------------------	---

## Mean Time Between Failures (MTBF)

**Table 23: SLX 9740 Mean Time Between Failures (MTBF)**

Device Model	Mean Time Between Failures
SLX9740-40C-AC-F	189,747 hrs @ 25°C
SLX9740-80C-AC-F	131,836 hrs @ 25°C
SLX9740-40C-DC-F	189,747 hrs @ 25°C

## CPU, Memory

**Table 24: CPU, Memory**

Both models
2.2GHz 64-bit CPU
2 x 16 Gb DDR4 SO-DIMM memory, 128 Gb SSD
16MB BIOS SPI Flash Memory
8 GB Deep Buffer for each BCM88690 MAC ASIC

## Standards

**Table 25: Safety Standards**

North American Safety of ITE	<ul style="list-style-type: none"> <li>UL 62368-1 (US)</li> <li>UL 60950-1 (US)</li> <li>CAN/CSA 22.2 #62368-1-14, Canada</li> <li>CAN/CSA 22.2 #60950-1-07, Canada</li> <li>Complies with FCC 21 CFR Chapter 1, Sub-chapter J in accordance with FDA &amp; CDRH requirements (US Laser Safety)</li> <li>CDRH Letter of Approval (US FDA Approval)</li> </ul>
European Safety of ITE	<ul style="list-style-type: none"> <li>EN 62368-1</li> <li>EN 60950-1</li> <li>EN 60825-1 Class 2 (Lasers Safety)</li> <li>2014/35/EU Low Voltage Directive</li> </ul>
International Safety of ITE	<ul style="list-style-type: none"> <li>AS/NZS 60950-1 (Australia /New Zealand)</li> <li>CB Report &amp; Certificate per IEC 60950-1 + National Differences</li> <li>CB Report &amp; Certificate IEC 62368-1</li> </ul>

**Table 26: EMI/EMC Standards**

North America EMC for ITE	<ul style="list-style-type: none"> <li>FCC 47 CFR part 15 Class A (USA)</li> <li>ICES-003 Class A (Canada)</li> </ul>
European EMC standards	<ul style="list-style-type: none"> <li>EN 55032 Class A</li> <li>EN 55024</li> <li>EN 55011</li> <li>EN 61000-3-2 (Harmonics)</li> <li>EN 61000-3-3 (Flicker)</li> <li>EN 300 386 (EMC Telecommunications)</li> <li>2014/30/EU EMC Directive</li> </ul>

**Table 26: EMI/EMC Standards (continued)**

International EMC certifications	<p>IEC 61000-4-2/EN 61000-4-2 Electrostatic Discharge, 8kV Contact, 16kV Air, Criteria B</p> <p>IEC 61000-4-3/EN 61000-4-3 Radiated Immunity 10V/m, Criteria A</p> <p>IEC 61000-4-4/EN 61000 -4-4 Transient Burst, 2kV, Criteria B</p> <p>IEC 61000-4-5/EN 61000-4-5 Surge, 1kV L-L, 2kV L-G, Level 3 Criteria B</p> <p>IEC 61000-4-6/EN 61000-4-6 Conducted Immunity, 0.15-80 Mhz, 10Vrms, 80%AM (1kHz) Criteria A</p> <p>IEC/EN 61000-4-11 Power Dips &amp; Interruptions, &gt;30%, 25 periods, Criteria C</p> <p>CISPER 32 Class A (International Emissions)</p> <p>CISPER 24 Class A (International Immunity)</p> <p>CISPER 11:2009 ED 5.0 Group 1, Class A</p> <p>AS/NZS CISPER 32</p>
Country-specific	<p>VCCI Class A (Japan)</p> <p>ACMA RCM (Australia)</p> <p>CCC Mark (China)</p> <p>KCC Mark, EMC Approval (Korea)</p> <p>BSMI (Taiwan)</p> <p>ANATEL (Brazil)</p> <p>NoM (Mexico)</p> <p>EAC mark (Russiam Belarus, Kazhakstan)</p> <p>NRCS (South Africa)</p>

**Table 27: Telecom Standards**

<p>EN/ETSI 300 386:2008 (EMC Telecommunications)</p> <p>EN/ETSI 300 019 (Environmental for Telecommunications)</p> <p>MEF9 and MEF14 certified for EPL, EVPL, and ELAN</p>
--

**Table 28: IEEE 802.3 Media Access Standards**

<p>IEEE 802.3ab 1000BASE-T</p> <p>IEEE 802.3z 1000BASE-X</p> <p>IEEE 802.3ae 10GBASE-X</p> <p>IEEE 802.3ba 40GBASE-X</p>
--



## Environmental Data

**Table 29: Environmental Data**

Environmental standards	EN/ETSI 300 019-2-1 v2.1.2 (2000 - 2009) - Class 1.2 Storage EN/ETSI 300 019-2-2 v2.1.2 (1999 - 09) - Class 2.3 Transportation EN/ETSI 300 019-2-3 v2.1.2 (2003 - 04) - Class 3.1e Operational EN/ETSI 300 753 (1997-10) - Acoustic Noise ASTM D3580 Random Vibration Unpackaged 1.5G
Temperature range	<ul style="list-style-type: none"> <li>• Front-to-back airflow: 0°C to 40°C (32°F to 104°F) up to 1800m (6,000 ft)</li> <li>• Back-to-front airflow: 0°C to 25°C (32°F to 77°F) up to 1800m (6,000 ft)</li> </ul>
Other operating conditions	Humidity: 5% to 90% relative humidity, non-condensing Altitude: 0 to 4,500 meters (14,763 feet) Storage temperature: -25°C to 55°C (-13°F to 131°F) Operational shock (half sine): 30 m/s <sup>2</sup> (3 G), 11 ms, 60 shocks Operational random vibration: 3 to 500 Hz at 1.5 G rms
Storage & transportation conditions (packaged)	Transportation temperature: -40°C to 70°C (-40°F to 158°F) Humidity: 5% to 95% relative humidity, non-condensing Packaged shock (half sine): 180 m/s <sup>2</sup> (18 G), 6 ms, 600 shocks Packaged sine vibration: 5 to 62 Hz at velocity 5 mm/s, 62 to 500 Hz at 0.2 G Packaged random vibration: 5 to 20 Hz at 1.0 ASD w/-3 dB/oct. from 20 to 200 Hz 14 drops minimum on sides and corners at 42 in (<15 kg box)

## 1600 W Power Supplies Technical Specifications

Three 1600 W power supply units are available for use with SLX 9740 switch routers:

- 1600W AC power supply - front-to-back airflow (part no. XN-ACPWR-1600W-F)
- 1600W AC power supply - back-to-front airflow (part no. XN-ACPWR-1600W-R)
- 1600W DC power supply - front-to-back airflow (part no. XN-DCPWR-1600W-F)

**Table 30: 1600 W Power Supplies: Unpackaged Dimensions**

1600 W power supply – AC front-to-back or back-to-front airflow	Height: 4.01 cm (1.58 in) Width: 8.63 cm (3.4 in) Depth: 24.00 cm (9.45 in)
1600 W power supply – DC front-to-back airflow	Height: 4.01 cm (1.58 in) Width: 8.63 cm (3.4 in) Depth: 25.50 cm (10.04 in)

**Table 31: 1600 W Power Supplies: Unpackaged Weight**

1600 W power supplies – all models, front-to-back and back-to-front airflow	1.15 kg (2.53 lb)
---	-------------------

**Table 32: 1600 W Power Supplies: Packaged Dimensions**

1600 W power supplies – all models, front-to-back and back-to-front airflow	Height: 6.50 cm (2.56 in) Width: 21.48 cm (8.46 in) Depth: 40.00 cm (15.75 in)
---	--

**Table 33: 1600 W Power Supplies: Packaged Weight**

1600 W power supplies – all models, front-to-back and back-to-front airflow	1.50 kg (3.31 lb)
---	-------------------

**Table 34: Power Specifications (AC Power Supplies)**

Voltage input range	90 to 264 V ~
Nominal input ratings	For FSG059: AC 100-120V~, 50/60Hz, 13A max.; 200-240V ~, 50/60Hz, 10A max. For FSE023: 200-240V~, 50/60Hz, 10A max.
Nominal input current at full loads	10 A at 90 V ~ (low-line) 3.7 A at 230 V ~ (high-line)
Line frequency range	47 to 63 Hz
Maximum inrush current	35 A
Output	For FSG059: +12V/133A (for input 200-240VAC or 240VDC), +12V/83A (for input 100-120VAC), +12Vsb/2.5A. Total output power not to exceed 1600W (200-240VAC or 240Vdc). Total output power not to exceed 1000W (100-120VAC). For FSG023: +12V/133A, +12Vsb/2.5A. Total output power not to exceed 1600W.

**Table 34: Power Specifications (AC Power Supplies) (continued)**

Power supply input socket	IEC 320 C14
Power cord input plug	IEC 320 C13
Power cord wall plug	Refer to <a href="#">Power Cord Requirements for AC-Powered Switches and AC Power Supplies</a> on page 91
Power supply cord gauge	16 AWG (1.0 mm <sup>2</sup> ) over 6 feet
Efficiency	Low Line: 88% at 50% load and 86% at 100% load High Line: 90% at 50% and 100% loads

**Table 35: Power Specifications (DC Power Supplies)**

Nominal input	-48 to -60 VDC
DC Voltage input range	+/-39VDC to +/-72VDC, 50A max.
Inrush Current	21 A peak
Maximum wire size	14 AWG (1.5 mm <sup>2</sup> copper stranded).
DC Output	+12.2V/131A, +12Vsb/2.5A
Power (W)	1600 W

**Table 36: Environmental Specifications**

Operating temperature (front-to-back airflow)	0°C to 45°C (normal operation)
Operating temperature (back-to-front airflow)	0°C to 45°C (normal operation)
Storage temperature	-40°C to 70°C
Operating humidity	5% to 95% relative humidity, non-condensing
Operational shock	30 m/s <sup>2</sup> (3 G)

## Power Cord Requirements for AC-Powered Switches and AC Power Supplies

An AC power cord is not included with the AC power supply.

Power cords used with AC-powered switches or AC power supplies must meet the following requirements:

- The power cord must be agency-certified for the country of use.
- The power cord must have an IEC320-C13 connector for connection to the switch or power supply.

- The power cord must have an appropriately rated and approved wall plug applicable to the country of installation.
- For cords up to 6 feet (2 m) long, the wire size must be 18 AWG (.75 mm<sup>2</sup>) minimum; over 6 feet, the minimum wire size is 16 AWG (1.0 mm<sup>2</sup>).

For details about obtaining AC power cords for use in your country, refer to <http://www.extremenetworks.com/product/powercords/>.



# Safety and Regulatory Information

---

[Safety and Regulatory Information](#) on page 93

## Safety and Regulatory Information

---



### Warning

Read the following safety information thoroughly before installing Extreme Networks products. Failure to follow this safety information can lead to personal injury or damage to the equipment.

Only trained and qualified service personnel (as defined in IEC 60950-1 and AS/NZS 3260) should install, replace, or perform service to Extreme Networks switches and their components. Qualified personnel have read all related installation manuals, have the technical training and experience necessary to be aware of the hazards to which they are exposed in performing a task, and are aware of measures to minimize the danger to themselves or other persons.

If you are located in the United States, install the system in accordance with the U.S. National Electrical Code (NEC).

## Considerations Before Installing

Consider the following items before you install equipment.

- For equipment designed to operate in a typical Telco environment that is environmentally controlled, choose a site that has the following characteristics:
  - Temperature-controlled and humidity-controlled, such that the maximum ambient room temperature shall not exceed 45°C (113°F).
  - Clean and free from airborne materials that can conduct electricity.
  - Well ventilated and away from sources of heat including direct sunlight.
  - Away from sources of vibration or physical shock.
  - Isolated from strong electromagnetic fields produced by electrical devices.
- For equipment designed to be installed in environments that are not environmentally controlled, such as outdoor enclosures, see the product data sheet or for environmental conditions, temperature, and humidity.
- Establish at least 3 inches clearance on all sides for effective ventilation. Do not obstruct the air intake vent on the front, side, or rear ventilation grills. Locate the system away from heat sources.

- Make sure that your equipment is placed in an area that accommodates the power consumption and component heat dissipation specifications.
- Make sure that your power supplies meet the site DC power or AC power requirements of all the network equipment.
- Racks for Extreme Networks equipment must be permanently attached to the floor. Failure to stabilize the rack can cause the rack to tip over when the equipment is removed for servicing.
- Do not operate the system unless all modules, faceplates, front covers, and rear covers are in place. Blank faceplates and cover panels are required for the following functions:
  - Preventing exposure to hazardous voltages and currents inside the equipment
  - Containing electromagnetic interference (EMI) that might disrupt other equipment
  - Directing the flow of cooling air through the equipment
- Ultimate disposal of this product should be handled according to all national laws and regulations.

## General Safety Precautions

Follow these guidelines:

- Do not try to lift objects that you think are too heavy for you.
- When you install equipment in a rack, load heavier devices in the lower half of the rack first to avoid making the rack top-heavy.
- Use only tools and equipment that are in perfect condition. Do not use equipment with visible damage.
- Route cables in a manner that prevents possible damage to the cables and avoids causing accidents, such as tripping.
- Do not place a monitor or other objects on top of the equipment. The chassis cover is not designed to support weight.
- To reduce the risk of fire, use only #26 AWG or larger telecommunications line cord. Use only copper conductors.
- Do not work on the system or connect or disconnect cables during periods of lightning activity.
- This equipment must be grounded. Never defeat the ground conductor or operate the equipment in the absence of a suitably installed ground conductor.

## Maintenance Safety

When you perform maintenance procedures on Extreme Networks equipment, follow these recommendations:

- Use only authorized accessories or components approved for use with this system. Failure to follow these instructions may damage the equipment or violate required safety and regulations.
- This system contains no customer serviceable components. Do not attempt to repair a chassis, power supply, module, or other component. In the event of failure, return

the defective unit to Extreme Networks for repair or replacement, unless otherwise instructed by an Extreme Networks representative.

- To remove power from the system, you must unplug all power cords from wall outlets. The power cord is the disconnect device to the main power source.
- Disconnect all power cords before working near power supplies, unless otherwise instructed by a product-specific maintenance procedure.
- Replace a power cord immediately if it shows any signs of damage.
- When you work with optical devices, power supplies, or other modular accessories, put on an ESD-preventive wrist strap to reduce the risk of electronic damage to the equipment. Connect the other end of the strap to an appropriate grounding point on the equipment rack or to an ESD jack on the chassis if one is provided. Leave the ESD-preventive wrist strap permanently attached to the equipment rack or chassis so that it is always available when you need to handle components that are sensitive to ESD.
- Install all cables in a manner that avoids strain. Use tie wraps or other strain relief devices.

## Cable Routing for LAN Systems

Extreme Networks equipment meets the requirements for LAN system equipment.

LAN systems are designed for intra-building installations; that is, cable runs between devices must be in the same building as the connected units, except under the conditions listed in the next paragraph.

As allowed in the USA by the National Electrical Code (NEC), this equipment can be connected between buildings if any one of the following conditions is true:

- Cable runs between buildings are less than 140 feet long.
- Cable runs between buildings are directly buried.
- Cable runs between buildings are in an underground conduit, where a continuous metallic cable shield or a continuous metallic conduit containing the cable is bonded to each building grounding electrode system.



### Caution

Failure to follow these requirements for cable routing conditions may expose the user to electrical shock and expose the unit to damage that can cause errors.

**Warning**

The Ethernet ports of the equipment and its sub-assemblies are suitable only for intra-building connections (within the same building) or for connections to unexposed wiring or cabling. (See the conditions listed above.) The Ethernet ports of this equipment or its sub-assemblies must not be metalically connected to interfaces that connect to the outside plant (OSP) or its wiring. Ethernet interfaces are designed for use only as intra-building interfaces (described as Type 2 or Type 4 ports in GR-1089-CORE, Issue 6) and require isolation from the exposed OSP wiring. The addition of Primary Protectors is not sufficient protection to connect these interfaces metalically to OSP wiring. This warning does not apply to T1/E1 ports because T1/E1 ports have built-in isolation and surge protection that allows them to be connected to OSP wiring.

## Installing Power Supply Units and Connecting Power

For the ratings and power input requirements of each power supply unit, see "Technical Specifications" or the data sheet for the power supply at [www.extremenetworks.com](http://www.extremenetworks.com).

**Warning**

Be sure to satisfy the requirements listed in this section when you install Extreme Networks power supplies or connect power.

When you install any power supply:

- Do not use excessive force when you insert a power supply into the bay.
- Do not attempt to open the power supply enclosure for any reason; the power supply does not contain user-serviceable parts. In the event of failure, return the defective power supply to Extreme Networks for repair or replacement.
- Do not put your hand into an open power supply bay when a power supply is not present.
- Before you work on equipment that is connected to power lines, remove all jewelry, including watches. Metal objects heat up when they are connected to power and ground and can cause serious burns or weld the metal object to the terminals.
- An electrical arc can occur when you connect or disconnect the power with power applied. This could cause an explosion in hazardous area installations. Be sure that power is removed from the device.
- When you install or replace equipment, always make the ground connection first and disconnect the ground connection last.

When you install DC power supplies or connect DC power:

- Extreme Networks DC power supplies do not have switches for turning the unit on and off. Make sure that the DC circuit is de-energized before connecting or disconnecting the DC power cord at the DC input power socket.



- Connect the system or power supply only to a DC power source that complies with the safety extra-low voltage (SELV) requirements in IEC 60950-based safety standards.

**Note**

Because building codes vary worldwide, Extreme Networks strongly recommends that you consult an electrical contractor to ensure proper equipment grounding and power distribution for your specific installation and country.

**Warning**

Extreme Networks power supplies do not have switches for turning the unit on and off. Disconnect all power cords to remove power from the device. Make sure that these connections are easily accessible.

Extreme Networks alimentations n'ont pas de contact pour mettre l'appareil sous et hors tension. Débranchez tous les cordons d'alimentation pour couper l'alimentation de l'appareil. Assurez-vous que ces connexions sont facilement accessibles.

## Selecting Power Supply Cords

You can purchase a power cord for your product and for your specific country from your local Extreme Networks Channel Account Manager or Sales Manager, or you can purchase a cord from your local supplier. Requirements for the power cord are listed in the Technical Specifications for your product.

To locate a Sales Manager or Partner in your region, visit [www.extremenetworks.com/partners/where-to-buy](http://www.extremenetworks.com/partners/where-to-buy).

**Note**

This equipment is not intended to be directly powered by power distribution systems where phase-phase voltages exceed 240 VAC (2P+PE), such as those used in Norway, France, and other countries. For these applications it is recommended that a transformer be used to step down the voltage to < 240 VAC from phase-phase, or that you make a connection to a (P+N+PE) power distribution where voltages do not exceed 240 VAC.

All installations should confirm that the product is reliably grounded according to the country's local electrical codes.

## Battery Notice



**Warning:** This product contains a battery used to maintain product information. If the battery should need replacement it must be replaced by Service Personnel. Please contact Technical Support for assistance.

Risk of explosion if battery is replaced by an incorrect type. Dispose of expended battery in accordance with local disposal regulations.



**Attention:** Ce produit renferme une pile servant à conserver les renseignements sur le produit. Le cas échéant, faites remplacer la pile par le personnel du service de réparation. Veuillez communiquer avec l'assistance technique pour du soutien.

Il y a risque d'explosion si la pile est remplacée par un type de pile incorrect. Éliminez les piles usées en conformité aux règlements locaux d'élimination des piles.



# Regulatory Statements

---

- [CE statement](#) on page 99
- [China ROHS](#) on page 99
- [BSMI statement \(Taiwan\)](#) on page 100
- [Canadian requirements](#) on page 100
- [China CCC statement](#) on page 101
- [Australia \(RCM\)](#) on page 101
- [Federal Communications Commission \(FCC\) Notice](#) on page 101
- [Germany statement](#) on page 102
- [KCC statement \(Republic of Korea\)](#) on page 102
- [Japan \(VCCI Class A\)](#) on page 102
- [Japan power cord](#) on page 103

## CE statement

---



### Important

This is a Class A product. In a domestic environment, this product might cause radio interference, and the user might be required to take corrective measures.

The standards compliance label on this device contains the CE mark which indicates that this system conforms to the provisions of the following European Council directives, laws, and standards:

- Electromagnetic Compatibility (EMC) Directive 2014/30/EU
- Low Voltage Directive (LVD) 2014/35/EU
- EN 55032/EN 55024 (European Immunity Requirements)
  - EN61000-3-2/IEIDA (European and Japanese Harmonics Spec)
  - EN61000-3-3

## China ROHS

---

Refer to the latest revision of the China ROHS document (P/N 53-1000428-xx) which ships with the product.

## BSMI statement (Taiwan)

---

警告使用者：

此為甲類資訊技術設備，於居住環境中使用時，可能會造成射頻擾動，在此種情況下，使用者會被要求採取某些適當的對策。

Warning:

This is Class A product. In a domestic environment this product may cause radio interference in which case the user may be required to take adequate measures.

## Canadian requirements

---

This Class A digital apparatus meets all requirements of the Canadian Interference-Causing Equipment Regulations, ICES-003 Class A.

Cet appareil numérique de la classe A est conforme à la norme NMB-003 du Canada.



device must accept any interference received, including interference that may cause undesired operation.



#### Note

This equipment has been tested and found to comply with the limits for a class A digital device, pursuant to Part 15 of the FCC rules. These limits are designed to provide reasonable protection against harmful interference when the equipment is operated in a commercial environment. This equipment uses, generates, and can radiate radio frequency energy and if not installed in accordance with the operator's manual, may cause harmful interference to radio communications. Operation of this equipment in a residential area is likely to cause interference in which case the user will be required to correct the interference at his own expense.

**WARNING:** Changes or modifications made to this device which are not expressly approved by the party responsible for compliance could void the user's authority to operate the equipment.

## Germany statement

---

Machine noise information regulation - 3. GPSGV, the highest sound pressure level value is 70.0 dB(A) in accordance with EN ISO 7779.

Maschinenlärminformations-Verordnung - 3. GPSGV, der höchste Schalldruckpegel beträgt 70.0 dB(A) gemäss EN ISO 7779.

## KCC statement (Republic of Korea)

---

A급 기기 (업무용 방송통신기기): 이 기기는 업무용(A급)으로 전자파적합등록을 한 기기이오니 판매자 또는 사용자는 이 점을 주의하시기 바라며, 가정외의 지역에서 사용하는 것을 목적으로 합니다.

Class A device (Broadcasting Communication Device for Office Use): This device obtained EMC registration for office use (Class A), and may be used in places other than home. Sellers and/or users need to take note of this.

## Japan (VCCI Class A)

---



#### Warning

This is a Class A product based on the standard of the VCCI Council. If this equipment is used in a domestic environment, radio interference may occur, in which case the user may be required to take corrective actions.

この装置は、クラスA情報技術装置です。この装置を家庭環境で使用すると電波妨害を引き起こすことがあります。この場合には使用者が適切な対策を講ずるよう要求されることがあります。

VCCI-A

## Japan power cord

---



**注意** - 添付の電源コードを他の装置や用途に  
使用しない

添付の電源コードは本装置に接続し、使用する  
ことを目的として設計され、その安全性が確認  
されているものです。決して他の装置や用途に  
使用しないでください。火災や感電の原因とな  
る恐れがあります。

*English translation of above statement*

ATTENTION: Never use the power cord packed with your equipment for other products.



# Cautions and Danger Notices

---

[Cautions](#) on page 104

[Danger Notices](#) on page 111

## Cautions

---

A Caution statement alerts you to situations that can be potentially hazardous to you or cause damage to hardware, firmware, software, or data.

Ein Vorsichtinweis warnt Sie vor potenziellen Personengefahren oder Beschädigung der Hardware, Firmware, Software oder auch vor einem möglichen Datenverlust

Un message de mise en garde vous alerte sur des situations pouvant présenter un risque potentiel de dommages corporels ou de dommages matériels, logiciels ou de perte de données.

Un mensaje de precaución le alerta de situaciones que pueden resultar peligrosas para usted o causar daños en el hardware, el firmware, el software o los datos.



## General cautions



### Caution

Changes or modifications made to this device that are not expressly approved by the party responsible for compliance could void the user's authority to operate the equipment.

VORSICHT	Falls dieses Gerät verändert oder modifiziert wird, ohne die ausdrückliche Genehmigung der für die Einhaltung der Anforderungen verantwortlichen Partei einzuholen, kann dem Benutzer der weitere Betrieb des Gerätes untersagt werden.
MISE EN GARDE	Les éventuelles modifications apportées à cet équipement sans avoir été expressément approuvées par la partie responsable d'en évaluer la conformité sont susceptibles d'annuler le droit de l'utilisateur à utiliser cet équipement.
PRECAUCIÓN	Si se realizan cambios o modificaciones en este dispositivo sin la autorización expresa de la parte responsable del cumplimiento de las normas, la licencia del usuario para operar este equipo puede quedar anulada.



### Caution

Disassembling any part of the power supply and fan assembly voids the warranty and regulatory certifications. There are no user-serviceable parts inside the power supply and fan assembly.

VORSICHT	Das Zerlegen von Netzteilen oder Lüftereinheiten macht die Garantie und die gesetzlichen Zertifizierungen ungültig. Die Netzteile und Lüftereinheiten enthalten keine Teile, die vom Benutzer gewartet werden können.
MISE EN GARDE	Le démontage d'une pièce du bloc d'alimentation ou du ventilateur annule la garantie et les certificats de conformité. Aucune pièce du bloc de l'alimentation ou du ventilateur ne peut être réparée par l'utilisateur.
PRECAUCIÓN	Si se desmonta cualquier pieza del módulo de fuente de alimentación y ventiladores, la garantía y las certificaciones normativas quedan

	anuladas. En el interior del módulo de fuente de alimentación y ventiladores no hay piezas que pueda reparar el usuario.
--	--

**Caution**

Make sure the airflow around the front, and back of the device is not restricted.

VORSICHT	Stellen Sie sicher, dass an der Vorderseite, den Seiten und an der Rückseite der Luftstrom nicht behindert wird.
MISE EN GARDE	Vérifiez que rien ne restreint la circulation d'air devant, derrière et sur les côtés du dispositif et qu'elle peut se faire librement.
PRECAUCIÓN	Asegúrese de que el flujo de aire en las inmediaciones de las partes anterior, laterales y posterior del instrumento no esté restringido.

**Caution**

Ensure that the airflow direction of the power supply unit matches that of the installed fan tray. The power supplies and fan trays are clearly labeled with either a green arrow with an "E", or an orange arrow with an "I."

VORSICHT	Vergewissern Sie sich, dass die Luftstromrichtung des Netzteils der eingebauten Lüftereinheit entspricht. Die Netzteile und Lüftereinheiten sind eindeutig mit einem grünen Pfeil und dem Buchstaben "E" oder einem orangefarbenen Pfeil mit dem Buchstaben "I" gekennzeichnet.
MISE EN GARDE	Veillez à ce que le sens de circulation de l'air du bloc d'alimentation corresponde à celui du tiroir de ventilation installé. Les blocs d'alimentation et les tiroirs de ventilation sont étiquetés d'une flèche verte avec un "E" ou d'une flèche orange avec un "I".
PRECAUCIÓN	Asegúrese de que la dirección del flujo de aire de la unidad de alimentación se corresponda con la de la bandeja del ventilador instalada. Los dispositivos de alimentación y las bandejas del ventilador están etiquetadas claramente con una flecha verde y una "E" o con una flecha naranja y una "I".

**Caution**

To protect the serial port from damage, keep the cover on the port when not in use.

VORSICHT	Um den seriellen Anschluss vor Beschädigungen zu schützen, sollten Sie die Abdeckung am Anschluss belassen, wenn er nicht verwendet wird.
MISE EN GARDE	Mettre le bouchon de protection sur le port série lorsqu'il ne sert pas pour éviter de l'endommager.
PRECAUCIÓN	Para evitar que se dañe el puerto serie, mantenga la cubierta colocada sobre el puerto cuando no lo utilice.

**Caution**

Never leave tools inside the chassis.

	Lassen Sie keine Werkzeuge im Chassis zurück.
--	---

VORSICHT	
MISE EN GARDE	Ne laissez jamais d'outils à l'intérieur du châssis
PRECAUCIÓN	No deje nunca herramientas en el interior del chasis.

**Caution**

If you do not install a module or a power supply in a slot, you must keep the slot filler panel in place. If you run the chassis with an uncovered slot, the system will overheat.

VORSICHT	Falls kein Modul oder Netzteil im Steckplatz installiert wird, muss die Steckplatztafel angebracht werden. Wenn ein Steckplatz nicht abgedeckt wird, läuft das System heiß.
MISE EN GARDE	Si vous n'installez pas de module ou de bloc d'alimentation dans un slot, vous devez laisser le panneau du slot en place. Si vous faites fonctionner le châssis avec un slot découvert, le système surchauffera.
PRECAUCIÓN	Si no instala un módulo o un fuente de alimentación en la ranura, deberá mantener el panel de ranuras en su lugar. Si pone en

	funcionamiento el chasis con una ranura descubierta, el sistema sufrirá sobrecalentamiento.
--	---

**Caution**

Use the screws specified in the procedure. Using longer screws can damage the device.

VORSICHT	Verwenden Sie die in der Anleitung aufgeführten Schrauben. Mit längeren Schrauben wird das Gerät möglicherweise beschädigt.
MISE EN GARDE	Utilisez les vis mentionnées dans les instructions. L'utilisation de vis plus longues peut endommager l'appareil.
PRECAUCIÓN	Utilice los tornillos especificados en el procedimiento. Si utiliza tornillos de mayor longitud, podría dañar el dispositivo.

**Caution**

Do not install the device in an environment where the operating ambient temperature might exceed 50°C (122°F).

VORSICHT	Das Gerät darf nicht in einer Umgebung mit einer Umgebungsbetriebstemperatur von über 50°C (122°F) installiert werden.
MISE EN GARDE	N'installez pas le dispositif dans un environnement où la température d'exploitation ambiante risque de dépasser 50°C (122°F).
PRECAUCIÓN	No instale el instrumento en un entorno en el que la temperatura ambiente de operación pueda exceder los 50°C (122°F).

**Caution**

The device must be turned off and disconnected from the fabric during this procedure.

VORSICHT	Bei diesem Verfahren muss das Gerät ausgeschaltet und von der Fabric getrennt sein.
MISE EN GARDE	Au cours de cette procédure, l'appareil doit être éteint et déconnecté du réseau.
PRECAUCIÓN	El dispositivo debe estar apagado y desconectado del fabric durante este procedimiento.

**Caution**

All devices with DC power supplies are intended for installation in restricted access areas only. A restricted access area is a location where access can be gained only by trained service personnel through the use of a special tool, lock and key, or other means of security, and is controlled by the authority responsible for the location.

VORSICHT	Alle Geräte mit DC-Netzteil sind nur für die Installation in Bereichen mit beschränktem Zugang gedacht. Ein Bereich mit beschränktem Zugang ist ein Ort, zu dem nur ausgebildetes
----------	---

	Wartungspersonal mit Spezialwerkzeug, Schloss und Schlüssel oder anderen Sicherheitsvorrichtungen Zugang hat. Dieser Zugang wird von für den Bereich zuständigen Personen überwacht.
MISE EN GARDE	Tous les équipements dotés de sources d'alimentation C.C. sont destinés à être installés uniquement dans des zones à accès réglementé. Une zone à accès réglementé est une zone dont l'accès n'est possible qu'au personnel de service qualifié utilisant un verrou, une clé ou un outil spécial, ou d'autres moyens de sécurité, et qui est contrôlée par les autorités responsables du site.
PRECAUCIÓN	Todos los dispositivos con fuentes de alimentación de corriente continua (CC) han sido diseñados únicamente para su instalación en áreas restringidas/ zonas de acceso restringido. Se entiende como área de acceso restringido un lugar al que solo puede acceder personal de servicio mediante el uso de una herramienta especial, llave y cerrojo u otro medio de seguridad similar, y que esté controlado por la autoridad responsable de esa ubicación.

**Caution**

Static electricity can damage the chassis and other electronic devices. To avoid damage, keep static-sensitive devices in their static-protective packages until you are ready to install them.

VORSICHT	Statische Elektrizität kann das System und andere elektronische Geräte beschädigen. Um Schäden zu vermeiden, entnehmen Sie elektrostatisch empfindliche Geräte erst aus deren antistatischer Schutzhülle, wenn Sie bereit für den Einbau sind.
MISE EN GARDE	L'électricité statique peut endommager le châssis et les autres appareils électroniques. Pour éviter tout dommage, conservez les appareils sensibles à l'électricité statique dans leur emballage protecteur tant qu'ils n'ont pas été installés.
PRECAUCIÓN	La electricidad estática puede dañar el chasis y otros dispositivos electrónicos. A fin de impedir que se produzcan daños, conserve los

	dispositivos susceptibles de dañarse con la electricidad estática dentro de los paquetes protectores hasta que esté listo para instalarlos.
--	---

**Caution**

Use a separate branch circuit for each power cord, which provides redundancy in case one of the circuits fails.

VORSICHT	Es empfiehlt sich die Installation eines separaten Stromkreisweiges für jede Elektroschnur als Redundanz im Fall des Ausfalls eines Stromkreises.
MISE EN GARDE	Utilisez un circuit de dérivation différent pour chaque cordon d'alimentation ainsi, il y aura un circuit redondant en cas de panne d'un des circuits.
PRECAUCIÓN	Use un circuito derivado separado para cada cordón de alimentación, con lo que se proporcionará redundancia en caso de que uno de los circuitos falle.

**Caution**

Ensure that the device does not overload the power circuits, wiring, and over-current protection. To determine the possibility of overloading the supply circuits, add the ampere (amp) ratings of all devices installed on the same circuit as the device. Compare this total with the rating limit for the circuit. The maximum ampere ratings are usually printed on the devices near the input power connectors.

VORSICHT	Stromkreise, Verdrahtung und Überlastschutz dürfen nicht durch das Gerät überbelastet werden. Addieren Sie die Nennstromleistung (in Ampere) aller Geräte, die am selben Stromkreis wie das Gerät installiert sind. Somit können Sie feststellen, ob die Gefahr einer Überbelastung der Versorgungsstromkreise vorliegt. Vergleichen Sie diese Summe mit der Nennstromgrenze des Stromkreises. Die Höchstnennströme (in Ampere) stehen normalerweise auf der Geräterückseite neben den Eingangstromanschlüssen.
MISE EN GARDE	Assurez-vous que le dispositif ne risque pas de surcharger les circuits d'alimentation, le câblage et la protection de surintensité. Pour déterminer le risque de surcharge des circuits d'alimentation, additionnez l'intensité nominale (ampères) de tous les dispositifs installés sur le même circuit que le dispositif en question. Comparez alors ce total avec la limite de charge du circuit. L'intensité nominale maximum en ampères est généralement imprimée sur chaque dispositif près des connecteurs d'entrée d'alimentation.
PRECAUCIÓN	Verifique que el instrumento no sobrecargue los circuitos de corriente, el cableado y la protección para sobrecargas. Para determinar la posibilidad de sobrecarga en los circuitos de suministros, añada las capacidades nominales de corriente (amp) de todos los instrumentos instalados en el mismo circuito que el instrumento. Compare esta suma con el límite nominal para el circuito. Las capacidades nominales de

	corriente máximas están generalmente impresas en los instrumentos, cerca de los conectores de corriente de entrada.
--	---

**Caution**

Before plugging a cable into any port, be sure to discharge the voltage stored on the cable by touching the electrical contacts to ground surface.

VORSICHT	Bevor Sie ein Kabel in einen Anschluss einstecken, entladen Sie jegliche im Kabel vorhandene elektrische Spannung, indem Sie mit den elektrischen Kontakten eine geerdete Oberfläche berühren.
MISE EN GARDE	Avant de brancher un câble à un port, assurez-vous de décharger la tension du câble en reliant les contacts électriques à la terre.
PRECAUCIÓN	Antes de conectar un cable en cualquier puerto, asegúrese de descargar la tensión acumulada en el cable tocando la superficie de conexión a tierra con los contactos eléctricos.

**Caution**

To prevent damage to the chassis and components, never attempt to lift the chassis using the fan or power supply handles. These handles were not designed to support the weight of the chassis.

VORSICHT	Alle Geräte mit Wechselstromquellen sind nur zur Installation in Sperrbereichen bestimmt. Ein Sperrbereich ist ein Ort, zu dem nur Wartungspersonal mit einem Spezialwerkzeug, Schloss und Schlüssel oder einer anderen Schutzvorrichtung Zugang hat.
MISE EN GARDE	Pour éviter d'endommager le châssis et les composants, ne jamais tenter de soulever le châssis par les poignées du ventilateur ou de l'alimentation. Ces poignées n'ont pas été conçues pour supporter le poids du châssis.
PRECAUCIÓN	Para prevenir daños al chasis y a los componentes, nunca intente levantar el chasis usando las asas de la fuente de alimentación o del ventilador. Tales asas no han sido diseñadas para soportar el peso del chasis.

## Danger Notices

A Danger statement indicates conditions or situations that can be potentially lethal or extremely hazardous to you. Safety labels are also attached directly to products to warn of these conditions or situations.

Ein Gefahrenhinweis warnt vor Bedingungen oder Situationen die tödlich sein können oder Sie extrem gefährden können. Sicherheitsetiketten sind direkt auf den jeweiligen Produkten angebracht um vor diesen Bedingungen und Situationen zu warnen.

Un énoncé de danger indique des conditions ou des situations potentiellement mortelles ou extrêmement dangereuses. Des étiquettes de sécurité sont posées directement sur le produit et vous avertissent de ces conditions ou situations.

Una advertencia de peligro indica condiciones o situaciones que pueden resultar potencialmente letales o extremadamente peligrosas. También habrá etiquetas

de seguridad pegadas directamente sobre los productos para advertir de estas condiciones o situaciones.



## General dangers



### Warning

The procedures in this manual are for qualified service personnel.

GEFAHR	Die Vorgehensweisen in diesem Handbuch sind für qualifiziertes Servicepersonal bestimmt.
DANGER	Les procédures décrites dans ce manuel doivent être effectuées par un personnel de maintenance qualifié.
PELIGRO	Los procedimientos de este manual deben llevarlos a cabo técnicos cualificados.



### Warning

Batteries used for RTC/NVRAM backup are not located in operator-access areas. There is a risk of explosion if a battery is replaced by an incorrect type. Dispose of used components with batteries according to local ordinance and regulations.

GEFAHR	Die für die RTC/NVRAM-Sicherung verwendeten Batterien, befinden sich nicht in für den Bediener zugänglichen Bereichen. Bei Ersetzen der Batterie durch einen falschen Typ besteht Explosionsgefahr. Entsorgen Sie gebrauchte Komponenten mit Batterien gemäß den lokalen Auflagen und Vorschriften.
DANGER	Les batteries utilisées pour la sauvegarde de l'horloge et de la mémoire ne sont pas remplaçables par l'opérateur. Il y a risque d'explosion si la batterie est remplacée par une d'un type incompatible. Jetez/recyclez les batteries conformément aux normes locales.
PELIGRO	Las baterías usadas para respaldo de RTC/NVRAM no se encuentran en áreas de acceso del operador. Existe riesgo de explosión si una batería

	es remplazada por un tipo incorrecto. Deshágase de los componentes usados con las baterías según las políticas y regulaciones locales.
--	--

**Warning**

To avoid high voltage shock, do not open the device while the power is on.

GEFAHR	Das eingeschaltete Gerät darf nicht geöffnet werden, da andernfalls das Risiko eines Stromschlags mit Hochspannung besteht.
DANGER	Afin d'éviter tout choc électrique, n'ouvrez pas l'appareil lorsqu'il est sous tension.
PELIGRO	Para evitar una descarga de alto voltaje, no abra el dispositivo mientras esté encendido.

**Warning**

Make sure the rack housing the device is adequately secured to prevent it from becoming unstable or falling over.

GEFAHR	Stellen Sie sicher, dass das Gestell für die Unterbringung des Geräts auf angemessene Weise gesichert ist, so dass das Gestell oder der Schrank nicht wackeln oder umfallen kann.
DANGER	Vérifiez que le bâti abritant le dispositif est bien fixé afin qu'il ne devienne pas instable ou qu'il ne risque pas de tomber.
PELIGRO	Verifique que el bastidor que alberga el instrumento está asegurado correctamente para evitar que pueda hacerse inestable o que caiga.

**Warning**

Make sure that the power source circuits are properly grounded, then use the power cord supplied with the device to connect it to the power source.

GEFAHR	Stellen Sie sicher, dass die Stromkreise ordnungsgemäß geerdet sind. Benutzen Sie dann das mit dem Gerät gelieferte Stromkabel, um es an die Stromquelle anzuschließen.
DANGER	Vérifiez que les circuits de sources d'alimentation sont bien mis à la terre, puis utilisez le cordon d'alimentation fourni avec le dispositif pour le connecter à la source d'alimentation.
PELIGRO	Verifique que circuitos de la fuente de corriente están conectados a tierra correctamente; luego use el cordón de potencia suministrado con el instrumento para conectarlo a la fuente de corriente

**Warning**

Before beginning the installation, see the precautions in "Power precautions."

GEFAHR	Vor der Installation siehe Vorsichtsmaßnahmen unter "Power Precautions" (Vorsichtsmaßnahmen in Bezug auf elektrische Ablagen).
DANGER	Avant de commencer l'installation, consultez les précautions décrites dans "Power Precautions" (Précautions quant à l'alimentation).
PELIGRO	Antes de comenzar la instalación, consulte las precauciones en la sección "Power Precautions" (Precauciones sobre corriente).

**Warning**

Be careful not to accidentally insert your fingers into the fan tray while removing it from the chassis. The fan may still be spinning at a high speed.

PELIGRO	Radiacion de Laser. No vea directamente con Instrumentos Opticos. Clase 1M de Productos de Laser.
警告	レーザ放射 光学器具で直接ビームを見ないこと クラス 1 M レーザ製品

**Warning**

Use only optical transceivers that are qualified by Extreme Networks, Inc. and comply with the FDA Class 1 radiation performance requirements defined in 21 CFR Subchapter I, and with IEC 60825 and EN60825. Optical products that do not comply with these standards might emit light that is hazardous to the eyes.

GEFAHR	Verwenden Sie nur optische Transceiver, die von Extreme Networks, Inc. zugelassen sind und die die Anforderungen gemäß FDA Class 1 Radiation Performance Standards in 21 CFR, Unterkapitel I, sowie IEC 60825 und EN60825 erfüllen. Optische Produkte, die diese Normen nicht erfüllen, können Strahlen aussenden, die für das menschliche Auge gefährlich sind.
DANGER	Utilisez uniquement des émetteurs-récepteurs optiques certifiés par Extreme Networks, Inc. et conformes aux exigences sur la puissance de rayonnement de catégorie 1 de la FDA définies au sous-chapitre 21 CFR I et à les normes IEC 60825 et EN60825. Les produits optiques non-conformes à ces normes sont susceptibles d'émettre une lumière dangereuse pour les yeux.
PELIGRO	Utilice sólo transceptores ópticos aprobados por Extreme Networks, Inc. y que cumplan con las normas IEC 60825 y EN60825, y con los estándares de rendimiento Clase 1 de FDA definidos en el subcapítulo I de 21 CFR. Los productos ópticos que no cumplan con estos estándares pueden emitir luz dañina para los ojos.