



ExtremeWireless™ 802.11ax Wi-Fi 6E Outdoor AP5050D Access Point

Installation Guide

9037683-01 Rev AC
March 2024



Copyright © 2024 Extreme Networks, Inc. All rights reserved.

Legal Notice

Extreme Networks, Inc. reserves the right to make changes in specifications and other information contained in this document and its website without prior notice. The reader should in all cases consult representatives of Extreme Networks to determine whether any such changes have been made.

The hardware, firmware, software or any specifications described or referred to in this document are subject to change without notice.

Trademarks

Extreme Networks and the Extreme Networks logo are trademarks or registered trademarks of Extreme Networks, Inc. in the United States and/or other countries.

All other names (including any product names) mentioned in this document are the property of their respective owners and may be trademarks or registered trademarks of their respective companies/owners.

For additional information on Extreme Networks trademarks, see: www.extremenetworks.com/company/legal/trademarks

Open Source Declarations

Some software files have been licensed under certain open source or third-party licenses.

End-user license agreements and open source declarations can be found at: <https://www.extremenetworks.com/support/policies/open-source-declaration/>



Table of Contents

Preface.....	5
Text Conventions.....	5
Documentation and Training.....	6
Help and Support.....	7
Subscribe to Product Announcements.....	7
Send Feedback.....	8
AP5050D Overview.....	9
New in this Guide.....	9
January, 2024.....	9
October, 2023.....	10
March, 2023 Revisions.....	10
AP5050D Features.....	11
Power Profile.....	12
Micro USB Console Port Information.....	13
Supported Accessories.....	13
AP5050D Status LED Activity Description.....	14
IQ Engine Status LED Activity.....	15
ExtremeCloud IQ Controller Status LED Activity.....	15
AP5050D Purchase Order Information.....	15
AP5050D Order Information.....	15
KT-147407-02 Bracket Order Information.....	16
KT-150173-01 Extension Arm Order Information.....	17
MBO-ART03 Bracket Order Information.....	17
Install the Access Point.....	18
Installation Do's and Don'ts.....	19
Installation Don'ts.....	20
Installation Do's.....	20
Access Point Bracket Usage and Mounting Options.....	21
Install the Access Point on a Wall.....	22
Install the Access Point on a Wall or Flat Surface Using the KT-147407-02 Bracket Parts.....	23
Install the Access Point Using KT-147407-02 Bracket Parts and KT-150173-01 Extension Arm.....	26
Install the Access Point Using KT-150173-01 Extension Arm.....	27
Install the Access Point on a Wall With the MBO-ART03 Bracket.....	29
Install the Access Point on a Wall Using MBO-ART02 Articulating Mounting Bracket.....	30
Install the Access Point on a Wall Using ACC-MBO-KT-AX Adapter and MBO- ART03 Articulating Mounting Bracket.....	32
Install the Access Point on a Pole.....	32

Install the Access Point on a Pole Using KT-147407-02 Bracket Parts.....	33
Install the Access Point on a Pole with the MBO-ART03 and KT-147407-02 Brackets.....	36
Install the Access Point on a Pole Using KT-147407-02 Bracket Parts and KT-150173-01 Extension Arm.....	37
Install the Access Point on a Pole Using MBO-ART02 Articulating Mounting Bracket and POLE01 Bracket.....	40
Install the Access Point on a Unistrut Structure Using the MBO-ART03 Bracket.....	42
Install the Plastic Service Panel on the Access Point.....	44
Secure the Access Point after Installation.....	46
Power or Pressure Washing Guidelines.....	47
Ground the Access Point.....	48
Connect the ETH1 or ETH0 Cable through the Service Panel Base.....	49
Connect the ETH1 or ETH0 Cable to the Access Point.....	52
Regulatory and Compliance Information.....	55
Safety Guidelines.....	55
Professional Installation Instruction.....	56
Installation personnel.....	56
Instructions d'installation professionnelle.....	56
FCC Notice (Part 15 - Class B).....	56
FCC Radiation Exposure Statement.....	57
Industry Canada Notice.....	58
Mexico Compliance Statement.....	59
Brazil Agência Nacional De Telecomunicações (Anatel) Statement.....	60
Taiwan Regulatory Statement.....	60
Thailand Regulatory Statement.....	61
MPE.....	61
United Kingdom (UK) and European Union (EU) Radiation Warning Statement.....	62
Extreme Networks UK Address.....	63
Extreme Networks EU Importer Address.....	63
European Waste Electrical and Electronic Equipment (WEEE) Notice.....	63
Declaration of Conformity in Languages of the European Community.....	63
Index.....	66



Preface

Read the following topics to learn about:

- The meanings of text formats used in this document.
- Where you can find additional information and help.
- How to reach us with questions and comments.

Text Conventions

Unless otherwise noted, information in this document applies to all supported environments for the products in question. Exceptions, like command keywords associated with a specific software version, are identified in the text.

When a feature, function, or operation pertains to a specific hardware product, the product name is used. When features, functions, and operations are the same across an entire product family, such as ExtremeSwitching switches or SLX routers, the product is referred to as *the switch* or *the router*.

Table 1: Notes and warnings





Icon	Notice type	Alerts you to...
	Tip	Helpful tips and notices for using the product
	Note	Useful information or instructions
	Important	Important features or instructions
	Caution	Risk of personal injury, system damage, or loss of data
	Warning	Risk of severe personal injury

Table 2: Text

Convention	Description
screen displays	This typeface indicates command syntax, or represents information as it is displayed on the screen.
The words <i>enter</i> and <i>type</i>	When you see the word <i>enter</i> in this guide, you must type something, and then press the Return or Enter key. Do not press the Return or Enter key when an instruction simply says <i>type</i> .
Key names	Key names are written in boldface, for example Ctrl or Esc . If you must press two or more keys simultaneously, the key names are linked with a plus sign (+). Example: Press Ctrl+Alt+Del
<i>Words in italicized type</i>	Italics emphasize a point or denote new terms at the place where they are defined in the text. Italics are also used when referring to publication titles.
NEW!	New information. In a PDF, this is searchable text.

Table 3: Command syntax

Convention	Description
bold text	Bold text indicates command names, keywords, and command options.
<i>italic text</i>	Italic text indicates variable content.
[]	Syntax components displayed within square brackets are optional. Default responses to system prompts are enclosed in square brackets.
{ x y z }	A choice of required parameters is enclosed in curly brackets separated by vertical bars. You must select one of the options.
x y	A vertical bar separates mutually exclusive elements.
< >	Nonprinting characters, such as passwords, are enclosed in angle brackets.
...	Repeat the previous element, for example, <i>member [member...]</i> .
\	In command examples, the backslash indicates a “soft” line break. When a backslash separates two lines of a command input, enter the entire command at the prompt without the backslash.

Documentation and Training

Find Extreme Networks product information at the following locations:

[Current Product Documentation](#)

[Release Notes](#)

[Hardware and software compatibility](#) for Extreme Networks products

[Extreme Optics Compatibility](#)

[Other resources](#) such as white papers, data sheets, and case studies

Extreme Networks offers product training courses, both online and in person, as well as specialized certifications. For details, visit www.extremenetworks.com/education/.

Help and Support

If you require assistance, contact Extreme Networks using one of the following methods:

Extreme Portal

Search the GTAC (Global Technical Assistance Center) knowledge base; manage support cases and service contracts; download software; and obtain product licensing, training, and certifications.

The Hub

A forum for Extreme Networks customers to connect with one another, answer questions, and share ideas and feedback. This community is monitored by Extreme Networks employees, but is not intended to replace specific guidance from GTAC.

Call GTAC

For immediate support: (800) 998 2408 (toll-free in U.S. and Canada) or 1 (408) 579 2826. For the support phone number in your country, visit: www.extremenetworks.com/support/contact

Before contacting Extreme Networks for technical support, have the following information ready:

- Your Extreme Networks service contract number, or serial numbers for all involved Extreme Networks products
- A description of the failure
- A description of any actions already taken to resolve the problem
- A description of your network environment (such as layout, cable type, other relevant environmental information)
- Network load at the time of trouble (if known)
- The device history (for example, if you have returned the device before, or if this is a recurring problem)
- Any related RMA (Return Material Authorization) numbers

Subscribe to Product Announcements

You can subscribe to email notifications for product and software release announcements, Field Notices, and Vulnerability Notices.

1. Go to [The Hub](#).
2. In the list of categories, expand the **Product Announcements** list.

3. Select a product for which you would like to receive notifications.
4. Select **Subscribe**.
5. To select additional products, return to the **Product Announcements** list and repeat steps 3 and 4.

You can modify your product selections or unsubscribe at any time.

Send Feedback

The Information Development team at Extreme Networks has made every effort to ensure that this document is accurate, complete, and easy to use. We strive to improve our documentation to help you in your work, so we want to hear from you. We welcome all feedback, but we especially want to know about:

- Content errors, or confusing or conflicting information.
- Improvements that would help you find relevant information.
- Broken links or usability issues.

To send feedback, do either of the following:

- Access the feedback form at <https://www.extremenetworks.com/documentation-feedback/>.
- Email us at documentation@extremenetworks.com.

Provide the publication title, part number, and as much detail as possible, including the topic heading and page number if applicable, as well as your suggestions for improvement.



AP5050D Overview

[New in this Guide](#) on page 9

[AP5050D Features](#) on page 11

[Power Profile](#) on page 12

[Micro USB Console Port Information](#) on page 13

[Supported Accessories](#) on page 13

[AP5050D Status LED Activity Description](#) on page 14

[AP5050D Purchase Order Information](#) on page 15

The AP5050D access point is a cloud-ready, stadium-optimized Wi-Fi 6E outdoor access point. It is rated 802.11ax with a directional antenna and it supports high density of users and devices.

It can be installed on a wall or mounted to a pole.

For a list of supported accessories, see [Supported Accessories](#) on page 13.



Note

The AP5050D has a 6 GHz radio. But the radio is disabled until the Automated Frequency Coordination (AFC) regulations are ratified. The ratification varies by region. The access point is for outdoor deployment only at initial release.

New in this Guide

The following sections shows the recent documentation revisions for this guide. Use this information to locate the latest updates.

January, 2024

Table 4: New and revised information

Section	Description
Industry Canada	Updated for WiFi 6E in Canada.
FCC Notice (Part 15 - Class B)	Updated for WiFi 6E in Canada.

October, 2023

Table 5: New and revised information

Section	Description
Install the Access Point on a Pole Using KT-147407-02 Bracket Parts	Updated graphic to show drainage holes on side of AP.
Install the Access Point on a Pole Using KT-147407-02 Bracket Parts and KT-150173-01 Extension Arm	Updated graphic to show drainage holes on side of AP.
Brazil Regulatory Statement	Updated for Compliance.
Mexico Regulatory Statement	
Taiwan Regulatory Statement	
Thailand Regulatory Statement	
Installation Do's and Don'ts	Updated torque specifications for gland caps.
Connect the ETH1 or ETH0 Cable through the Service Panel Base	
Install the Access Point on a Unistrut Structure Using the MBO-ART03 Bracket	

March, 2023 Revisions

Table 6: New and revised information

Section	Description
MBO-ART03 Bracket Order Information	MBO-ART03 order information.
Access Point Bracket Usage and Mounting Options	The ART03 bracket replaces the ART02 bracket. It is an articulating mounting bracket with the following features: <ul style="list-style-type: none"> Adjustable 7.5", 9", and 10.5" extension with 2-axis +/-80 degree in 10 degree increments
Install the Access Point on a Wall	You can use the ACC-MBO-KT-AX Adapter and MBO-ART03 Articulating Mounting Bracket when you install your access point on an outside wall.
Install the Access Point on a Unistrut Structure	You can use the MBO-ART03 with a unistrut structure.
Install the Access Point on a Pole	You can use the KT-147407-02 and MBO-ART03 when you install your access point on an outside pole.
Install the Access Point on a Wall Using ACC-MBO-KT-AX Adapter	Use the MBO-ART03 articulating mounting bracket with the ACC-MBO-KT-AX Adapter for wall installations.

AP5050D Features

The following list shows the AP5050D hardware features. Use this information to further your understanding of the AP5050D technical specifications and features.

- Radios:
 - Tri-radio design 2.4 GHz (4x4:4), 5 GHz (4x4:4) and 6 GHz (4x4:4)

**Note**

The 6 GHz radio is disabled until Automated Frequency Coordination (AFC) regulations are ratified. The access point is for outdoor deployment only at initial release.

- One IoT Radio (BLE/802.15.4)
- Two Ethernet ports (ETH0 and ETH1):
 - ETH0 is 1 x 100/1000/2500/5000 Mbps auto-negotiation Ethernet port, RJ45 (Power over Ethernet - PoE)
 - ETH1 is 1 x 100/1000/2500 Mbps auto-negotiation Ethernet port, RJ45 (PSE)
- Dimensions: 11.3 in. x 18.8 in. x 2.9 in. (288 mm x 478 mm x 75 mm)
- One dual LED

For LED activity description, see [AP5050D Status LED Activity Description](#) on page 14.

- 3 mm diameter safety hanger provision
- Power: PoE 802.3at and 802.3bt: PSE enabled with 4x4x4
- For complete power profile information, refer to the AP5050U [power profile](#).
- Antenna:
 - Two software selectable internal antennas (30 degree and 70 degree directional antennas)
- Temperature:
 - -40°C to +60°C (-40°F to +140°F) operating temperature
 - -40 °C to +70 °C (-40 °F to +158 °F) storage temperature
- Enclosure: Plastic top enclosure and aluminum bottom
- One micro USB console port for troubleshooting or debugging issues

You can order a micro USB console adapter for your access point using the part number ACC-WIFI-MICRO-USB.

Consult the following illustration for information on the AP5050D side ports. For more information, see the [Universal Wireless AP5050U and AP5050D data sheet](#).

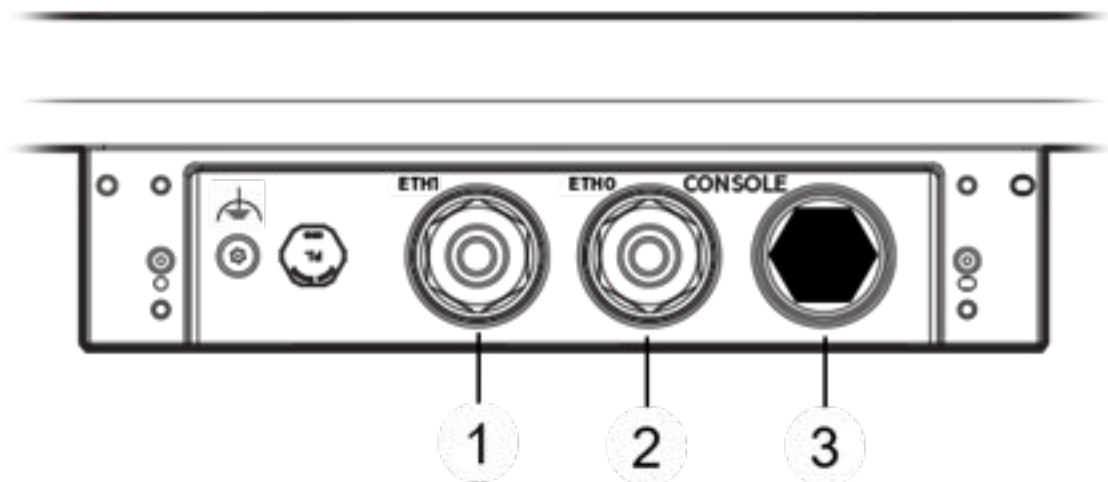

Figure 1: AP5050D Side Ports

Table 7: AP5050D Side Ports Descriptions

Callout	Description
1	Eth1 is 2.5/1GE/100 with PoE power sourcing equipment (PSE) 15.4W when 802.3bt on Eth0
2	Eth0 is 5/2.5/1GE with Power over Ethernet (PoE)
3	Console port for troubleshooting

Power Profile

The following table shows the power profile for the AP5050D. Use this information when you plan your deployment.

Table 8: AP5050D Power Profile

	AT profile	BT profile
2.4G RF	18dBm, 4x4	18dBm, 4x4
5G RF	18dBm, 4x4	18dBm, 4x4
6G RF	18dBm, 4x4	18dBm, 4x4
BLE	Yes	Yes
2nd Ethernet port	Yes	Yes
PSE (15.4W)	No	Yes

Micro USB Console Port Information

Use the console port to make a serial connection between your management system and the access point. You can order a micro USB console adapter for your access point using the part number ACC-WIFI-MICRO-USB.



Note

When you connect to the Micro USB console port, the management station from which you connect to the device must have a VT100 emulation program, such as TeraTerm Pro (a free terminal emulator) or Hilgraeve HyperTerminal (provided with Windows operating systems from XP forward).

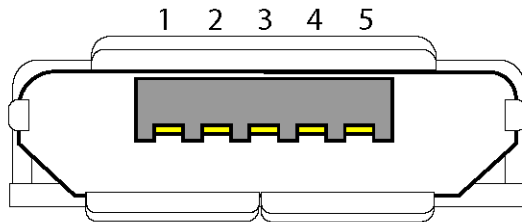

Figure 2: Micro-B model Console Port Pin Information

Table 9: Micro-B USB Pin Information

Pin number	Pin name and description
1	NC
2	RxD (input to access point)
3	TxD (output to terminal)
4	Signal (GND)
5	Signal (GND)

Supported Accessories

The table below lists the accessories available for your access point. For additional information, see [802.11ax and Cloud Access Points Accessories](#).



Note

The Hardware Kit ships with the AP5050D.

Table 10: Available Accessories

Accessory	Description	Comment
ACC-CAT6-LAN-GSKT	A black gasket.	For use with a CAT6 and CAT6A LAN cables.
ACC-WIFI-MICRO-USB	Micro USB cable	Used for troubleshooting issues.

Table 10: Available Accessories (continued)

Accessory	Description	Comment
KT-147407-02	A stainless steel mounting kit for mounting access points outdoors.	For use on all outdoor access points though some outdoor access points require an adaptor bracket.
KT-150173-01	A 12-inch extension arm for pole and wall mounting. You must use KT-147407-02 for pole mounting.	Use this arm when a standoff distance is required. It provides a minimum standoff distance of twelve inches and helps avoid interference with the antennas. For use on all outdoor access points though some outdoor access points require an adaptor bracket.
MBO-ART03	An outdoor access point (OAP) mounting bracket having +/-80 degree tilt on 2-axis and an adjustable 7.5", 9" or 10.5" extension capability.	Use this bracket for wall mounts and Unistrut brackets; it can also be used for mounting on a pole with the pole section from KT-147407-02.
MBO-ART02 Note: The MBO-ART02 wall mount bracket is End of Sale (EOS) as of January, 2023. It is replaced by the MBO-ART03 bracket.	A wall mounting bracket with +/- 80-degree that can be adjusted in 20-degree increments. It also has a 2-axis tilt and 10 -inch extension.	Use this bracket for outdoor use.
30520 The 30520 wireless mounting kit is End of Sale (EOS).	WS-MBO-POLE01. A pole mounting bracket.	Use this bracket with MBO-ART02 for pole mounting the MBO-ART02.

AP5050D Status LED Activity Description

The access point has one status light on top of the chassis. The status light conveys operational states for system power, firmware updates, Ethernet and wireless interface activity, and major alarms.

IQ Engine Status LED Activity

The following list shows the operational information for IQ Engine:

- Dark: Power is Off.
- Solid white: The device power is on and the access point is ready to use. The device has successfully established a Control And Provisioning of Wireless Access Points (CAPWAP) connection to ExtremeCloud IQ and is operating normally.
- Slow-blinking white: The device has a CAPWAP connection to ExtremeCloud IQ, but is operating on 802.3at power instead of 802.3bt power.
- Solid amber: The device power is on and the access point is in boot up mode, or is running without a CAPWAP connection.
- Slow-blinking amber: The device has no CAPWAP connection to ExtremeCloud IQ, and is operating on 802.3at power instead of 802.3bt power.
- Fast-blinking amber: The device is updating its IQ Engine firmware.

ExtremeCloud IQ Controller Status LED Activity

The following list shows the ExtremeWireless WING status:

- Dark: The LED power is off or the LED has been de-activated.
- Solid white: The device is booting or already taken over by the controller.
- Slow-blinking white: The device is in the process of being taken over by the controller or has failed to be taken over by the controller.
- Flashing fading white: Configuration pushes down to access point from controller helping an user to locate the access point location using visual inspection.
- Solid amber: The access point is upgrading its firmware.
- Fast-blinking amber: The access point is acquiring DHCP IP.

AP5050D Purchase Order Information

Use this information to order your access point and accessories.

AP5050D Order Information

The AP5050D access point is sold by itself, and you must order the mounting brackets and accessories separately for wall, or pole installations.

The ordering details are described in the following table.

Table 11: AP5050D Part Number

Part number	Description
AP5050D-WW	Outdoor tri-radio WiFi 6E access point (4x4:4), 2.4 GHz, 5GHz, 6GHz, and multirate port, internal directional antennas. Domain: World SKU

KT-147407-02 Bracket Order Information

You can install the access point to a wall using the KT-147407-02 bracket parts (+/-15 degree, 1-axis) or the MBO-ART02 (20 degree increments +/-80 degrees, 10 inch extension).

You can install the access point to a pole using:

- KT-147407-02 bracket parts (+/-15 degree, 1-axis), or
- MBO-ART03 (10 degree increments +/-80 degree on 2-axis, variable 7.5", 9" or 10.5 inch extension) with the KT 147407-02 bracket, or
- MBO-ART02 (20 degree increments +/-80 degree, 10 inch extension) with the WS-MBO-POLE01 (#30520) bracket.

You can attach the access point to a wall using the MBO-ART02 bracket. However, if you are using the MBO-ART02 bracket to attach the access point to a pole, you must use the WS-MBO-POLE01 bracket. You cannot attach the access point directly to a pole using the WS-MBO-POLE01 bracket.



Note

The WS-MBO-POLE01 bracket is End of Sale (EOS) as of January, 2023.
The MBO-ART02 wall mount bracket is End of Sale (EOS) as of January, 2023. It is replaced by the MBO-ART03 bracket.

The ordering details are described in the following table.

Table 12: KT-147407-02 Purchase Information

Part number	Box contents
KT-147407-02 Note: The cable clamps must be provided if KT-147407-02 is to be used for pole mounting.	The KT-147407-02 bracket comes with three bracket parts: <ul style="list-style-type: none"> • Flat part with holes on the metal surface • 1-axis tilt part • Boxed pole part with step edges
	Six hex-head M6 stainless-steel screws
	Two hex-head M12 stainless-steel screws
	Two hex M12 stainless-steel nuts
	One URL card

The KT-147407-02 bracket kit can be used with KT-150173-01 extension arm for adding +/-15 degree tilt to wall or pole installations.



Note

You must purchase the KT-150173-01 extension arm separately. But only 1 KT-147407-02 needs to be ordered per KT-150173-01 as one KT-147407-02 provides +/-15 degree tilting, pole mounting capability, or both tilting and pole mounting.

KT-150173-01 Extension Arm Order Information

The contents of the KT-150173-01 extension arm are described in the following table.

Table 13: KT-150173-01 Extension Arm Purchase Information

Part number	Box contents
KT-150173-01	One KT-150173-01 12 in. extension arm
	Two hex-head M12 stainless-steel screws
	Two hex M12 stainless-steel nuts
	One URL card



Note

You must provide the required M6 hex-head screws and nuts for flat surface installation.

MBO-ART03 Bracket Order Information

The ordering details are described in the following table.

Table 14: MBO-ART03 Bracket Purchase Information

Part number	Box contents
MBO-ART03	MBO-ART03: Adjustable 7 to 10 inch mounting bracket with +/- 80 degree 2-axis (in 10 degree increments) angular adjustment.
	Four stainless-steel M8 screws
	Two M6 long hex head screws and hex nuts with lock washer.
	One URL card



Install the Access Point

[Installation Do's and Don'ts](#) on page 19

[Access Point Bracket Usage and Mounting Options](#) on page 21

[Install the Access Point on a Wall](#) on page 22

[Install the Access Point on a Pole](#) on page 32

[Install the Access Point on a Unistrut Structure Using the MBO-ART03 Bracket](#) on page 42

[Install the Plastic Service Panel on the Access Point](#) on page 44

[Secure the Access Point after Installation](#) on page 46

[Power or Pressure Washing Guidelines](#) on page 47

About This Task

The AP5050D access point can be installed on a wall or to a pole. The [AP5050D Purchase Order Information](#) on page 15 gives you more details about choosing the right access point bracket for your installation needs.



Note

The access point ships with two black gaskets in the box for use with Category 6 (CAT 6) Ethernet cables with a cable diameter from 6.0mm to 9.2mm. This includes shielded and unshielded twisted-pair (UTP) Cat 6 and 6A cables. Store these gaskets in a safe place if you do not use them right away.

The access point has light-gray gaskets pre-installed in the access point glands. The light-gray gasket handles all CAT 5 and CAT 5E cables, with a cable diameter range from 4.5mm to 6.0mm.

Procedure

1. Review the [purchase order information](#).
2. Visually inspect the access point and any other bracket and optional accessories you have ordered for physical damage.
If there is any damage, contact [Extreme Networks Support](#).
3. Review the [safety guidelines](#).
4. Be familiar with the information in the installation guide, in particular the [installation do's and don'ts](#).

Installation Do's and Don'ts

Learn about various do's and don'ts for each installation option before installing the access point.

The following diagram shows the AP5050D gland body components. Be familiar with each component before you install the access point.

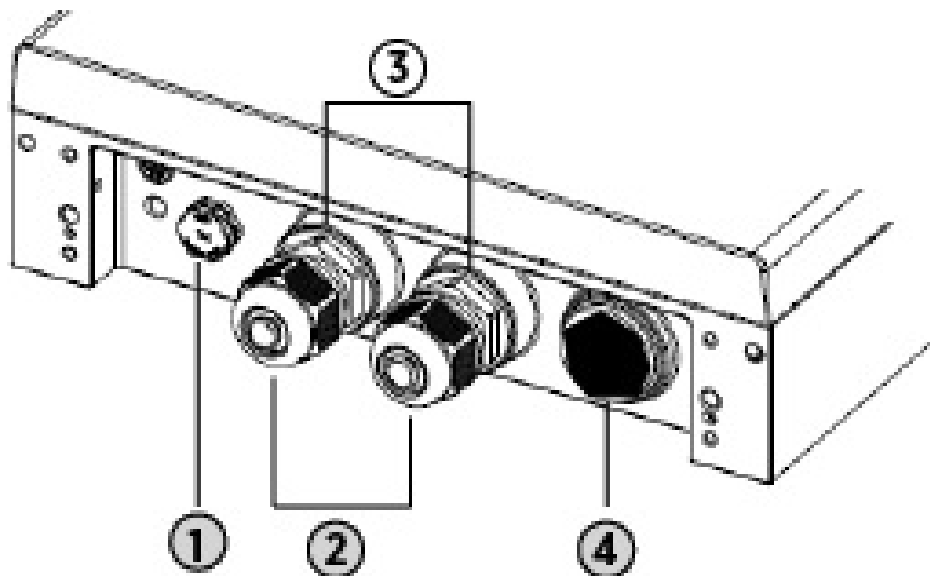

Figure 3: AP5050D Gland Body

Table 15: Gland Body Features

Callout	Description
1	Vent - do not loosen the vent. Note: Do NOT remove the vent or it's protective cap.
2	Gland cap hex - remove only as needed to attach a LAN cable. Tighten to 12 inch-lbs

Table 15: Gland Body Features (continued)

Callout	Description
3	Gland body hex Note: Do not loosen or unscrew the gland body hex.
4	Console cap hex - retighten to 15 in-lbs.

Installation Don'ts

Keep the following items in mind as you install your access point.

- Do **NOT** install the access point side with the user input/output facing upward or angled upward, toward the sky.
- Do **NOT** install the access point or open the console cap when precipitation is falling or is about to fall.
- Do **NOT** remove the gland body. If the gland body is accidentally loosened, it must be torqued immediately to 30 in-lbs.



Important

The gland body keeps water from entering the access point.



Note

The access point ships with two black gaskets in the box for use with Category 6 (CAT 6) Ethernet cables with a cable diameter from 6.0mm to 9.2mm. This includes shielded and unshielded twisted-pair (UTP) Cat 6 and 6A cables. Store these gaskets in a safe place if you do not use them right away.

The access point has light-gray gaskets pre-installed in the access point glands. The light-gray gasket handles all CAT 5 and CAT 5E cables, with a cable diameter range from 4.5mm to 6.0mm.

- Do **NOT** let moisture, dirt, pollen, or any other debris enter the glands or the console.
- Do **NOT** get a pressure washer nozzle closer than 24 inches to the glands, console cap, or vent.

Installation Do's:

Orientation:

- The access point can be mounted in almost any orientation.



Note

The only mounting orientation restriction is with the access point glands. The best practice is to have the glands on the downward side to maximize water draining away from the glands.

- The side with the glands can be horizontal, facing down (ideal position), or anything in-between.

User I/O:

- Only the gland caps must be removed to install the ETH0 or ETH1 LAN RJ45 cable. Torque the gland caps to 12 in-lbs.
- The LAN cables must have a minimum radius of 1-in. and a 3-in. minimum drip loop. The drip loop allows gravity to carry moisture away from the glands.
- The console cap must be removed to install the console LAN RJ45 cable. Torque the console cap to 15 in-lbs.
- If used, torque the ground screw to a minimum of 12 in-lbs.

Power or Pressure Washers:

- The best practice is to keep a minimum distance of 24 inches between the pressure washer nozzle and the access point.
- Ensure that the maximum water pressure does not exceed 4000 psi.
- Fifteen degrees (15 degrees) is the narrowest nozzle that can be used for pressure washing.

Access Point Bracket Usage and Mounting Options

The AP5050D access point can be mounted on a wall, or to a pole, which are described in the following table.

**Warning**

When installing the access point on a wall or to a pole, the cable glands must face down.

Table 16: AP5050D Mounting Bracket Usage

Mounting bracket and part number	Unistrut install	Wall install	Pole install	Notes
KT-147407-02 bracket; comes with three bracket parts	No	Yes	Yes	For attaching to a wall or a flat surface, use the bracket part that has two holes. For attaching to a pole, attach the KT-147407-02 pole part on top of the 1-axis tilt part
KT-150173-01; extension arm	No	Yes. For +/-15 degree tilt: attach the KT-150173-01 extension arm to the 1-axis KT-147407-02 tilt part.	Yes, when paired with the KT-147407-02 bracket.	None

Table 16: AP5050D Mounting Bracket Usage (continued)

Mounting bracket and part number	Unistrut install	Wall install	Pole install	Notes
MBO-ART03	Yes	Yes	Yes, when paired with the KT-147407-02 bracket.	Adjustable 7.5", 9", and 10.5" extension with 2-axis +/-80 degree (in 10 degree increments) articulating mounting bracket. For wall installations, the wall must be strong enough to support the access point during inclement weather
MBO-ART02 The MBO-ART02 wall mount bracket is End of Sale (EOS) as of January, 2023. It is replaced by the MBO-ART03 bracket.	No	Yes	Yes, when paired with the 30520 (WS-MBO-POLE01) bracket.	The articulating mounting bracket is paired with the POLE01 bracket for pole installations. For wall installations, the wall must be strong enough to support the access point during inclement weather
30520 (WS-MBO-POLE01 bracket) The 30520 wireless mounting kit is End of Sale (EOS).	No	No	Yes (must be used with the MBO-ART02 bracket)	If the pole diameter is <= 1.0 in. (25.4 mm), use small cable clamp. If the pole diameter is between 5.0 in. - 7.0 in. (178.0 mm), use large cable clamp. For any other pole diameter, provide your own stainless steel cable clamp. The band must be 0.5 in. (12.7 mm) wide The POLE01 bracket can be used only when paired with the MBO-ART02 bracket

Install the Access Point on a Wall

Before You Begin

The access point can be attached to a wall or flat surface with:

- KT-147407-02 (+/-15 degree tilt)
- KT-150173-01 (12 inch rigid extension)

- KT-147407-02 plus KT-150173-01 (12 inch extension plus +/-15 degree tilt)
- MBO-ART03 (7.5", 9" or 10.5" extension plus 2 axis +/-80 degree tilt)

**Note**

The MBO-ART02 wall mount bracket is End of Sale (EOS) as of January, 2023. It is replaced by the MBO-ART03 bracket.

The following hardware is required when installing the access point on a flat surface using the KT-147407-02 bracket:

- One access point
- Flat part of the KT-147407-02 bracket with two holes on the metal surface.
- 1-axis tilt bracket.
- KT-150173-01 extension arm and associated M12 hardware. (optional)
- Six M6 screws for KT-147407-02 bracket, and bracket to AP, assembly.
- Four M6 size hex-head screws for attachment of the bracket to the wall.
- Screw-in anchors if the access point is being mounted on a wood wall or a concrete surface.

**Note**

The M6 hex-head screws and screw-in anchors must be provided by the installer.

If you install the access point to the wall using the ART03 bracket, use the following hardware:

- One access point
- MBO-ART03 articulating mounting bracket
- Four M6 hex-head screws
 - Two M6 hex-head screws to attach the bracket to the access point
 - Two M6 hex-head screws to attach the bracket to the wall or a flat surface.

**Note**

The cable glands should face down when you install the access point on a wall.

Install the Access Point on a Wall or Flat Surface Using the KT-147407-02 Bracket Parts

Before You Begin

Obtain the following items:

- Flat part of the KT-147407-02 bracket
- 1-axis tilt part of the KT-147407-02 bracket
- One access point
- Six M6 screws
- Four M6 headsized screws

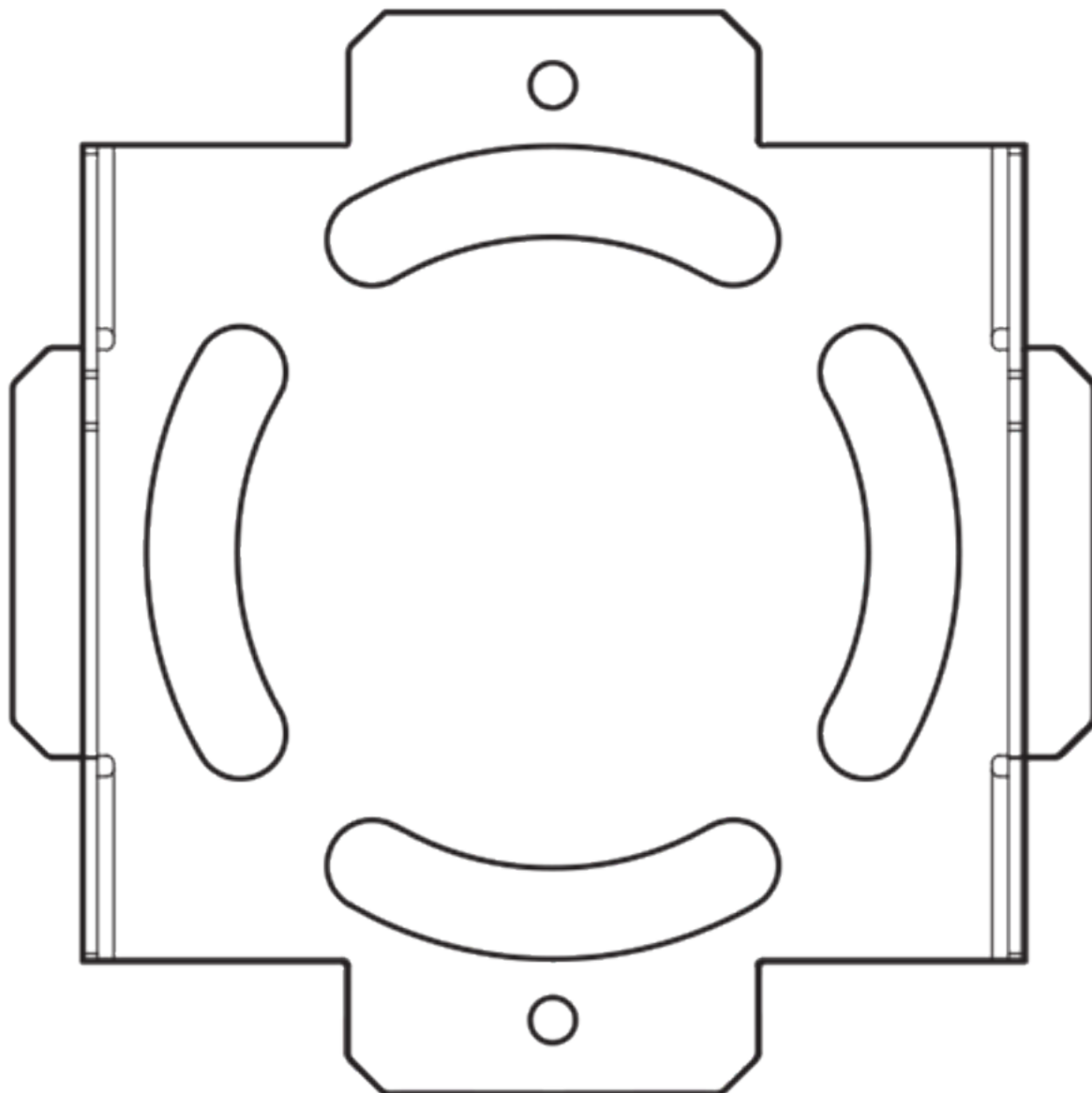

Figure 4: Flat Part of the KT-147407-02 Bracket

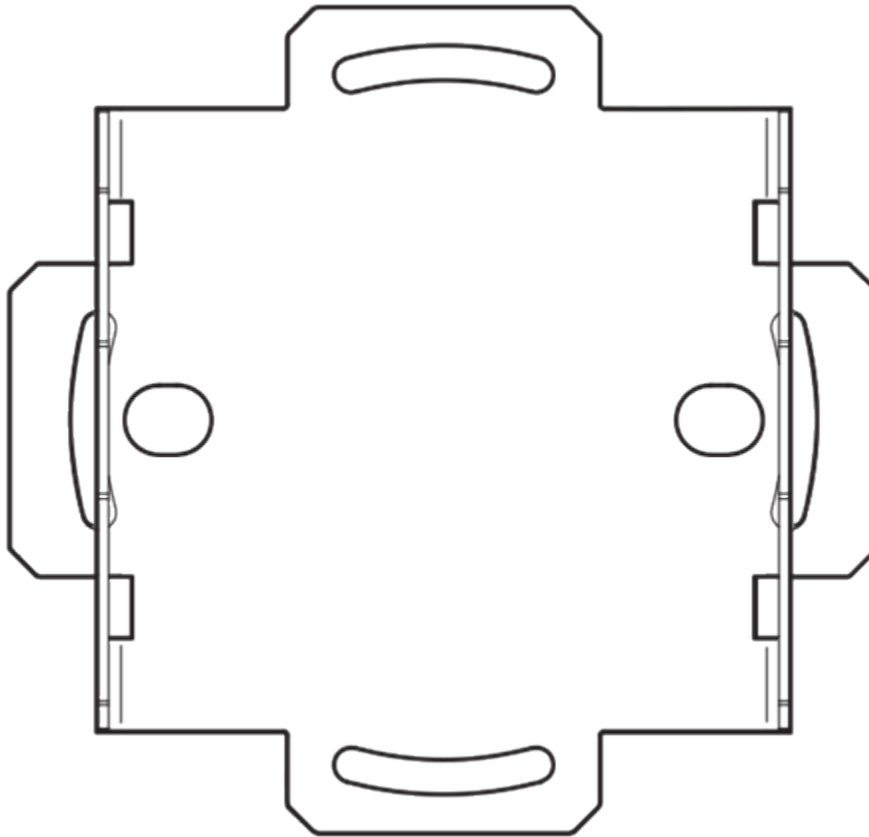

Figure 5: 1-axis Tilt Bracket

About This Task

Use the following information when you install the access point on a wall or flat surface with the KT-147407-02 bracket.

Procedure

1. Attach the flat part of the KT-147407-02 bracket to the access point using two M6 screws.
2. Using the 1-axis tilt bracket as a template, mark and drill four holes on a wall or on a flat surface.
3. Attach the 1-axis tilt bracket to a wall or flat surface using four M6 headsize screws.
4. Align the 1-axis tilt bracket part inside the flat part of the KT-147407-02 bracket, and attach the flat bracket to the 1-axis tilt bracket using four M6 screws.
5. Tilt the access point to a desired angle and tighten the four M6 screws to a torque of 45 in-lbs.

The tilt bracket has +15 degrees to -15 degrees of tilt.

Install the Access Point Using KT-147407-02 Bracket Parts and KT-150173-01 Extension Arm

Before You Begin

The hardware required for installation:

- Flat part of the KT-147407-02 bracket
- 1-axis tilt part of the KT-147407-02 bracket
- KT-150173-01 extension arm
- One access point

About This Task

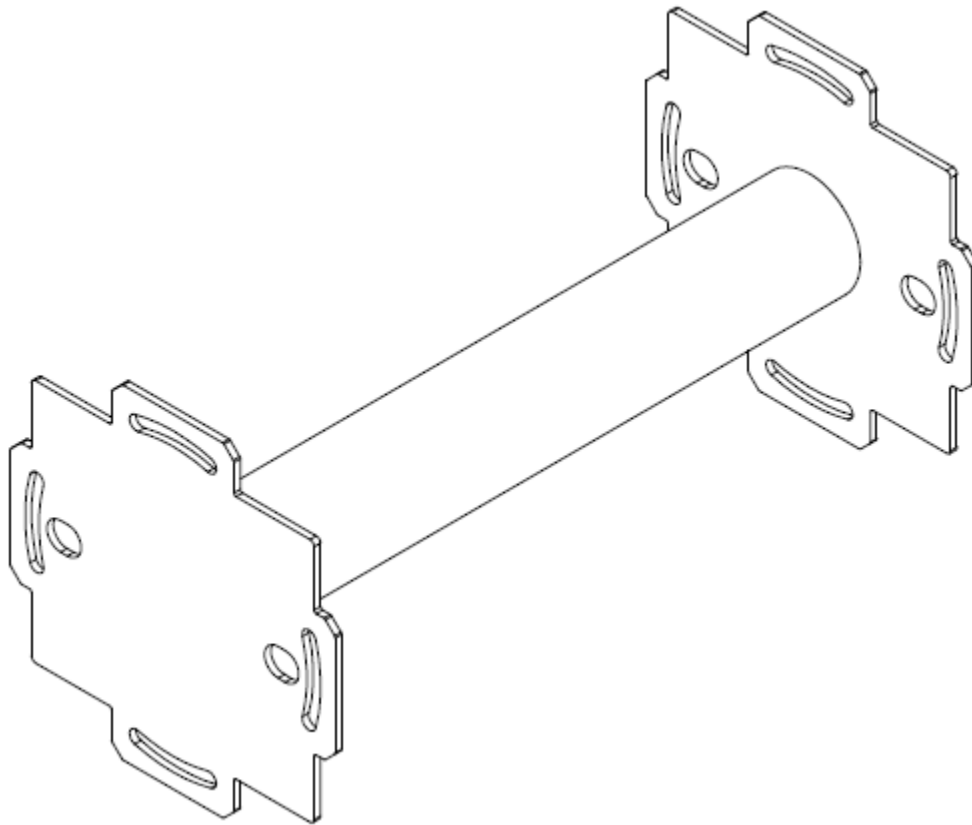

Figure 6: KT-150173-01 Extension Arm

The KT-150173-01 extension arm is used in combination with the wall and pole bracket parts of the KT-147407-02 bracket.

Procedure

1. Attach the flat part of the KT-147407-02 bracket to the access point using two M6 screws.
2. Using the KT-150173-01 extension arm as a template, mark and drill four hole centers on a flat surface.

The holes must be within the circular cuts in the end of the flange.

3. Place the flat part of the KT-147407-02 bracket inside the 1-axis tilt bracket, and attach the 1-axis tilt bracket to the flat bracket using four M6 screws.
4. Attach one end of the KT-150173-01 extension arm to the 1-axis tilt bracket using two hex-head M12 stainless-steel screws and two hex-head M12 stainless-steel nuts through the two large circular holes on the KT-150173-01 extension arm.
5. Attach the KT-150173-01 extension arm, that now has the access point mounted on the other end, to a flat surface using four M6 size hex-head screws.

Use screw-in anchors with the four M6 hex-head screws when you mount the bracket on a wood surface and use concrete anchors for concrete surface.

Install the Access Point Using KT-150173-01 Extension Arm

Before You Begin

Obtain the following hardware:

- KT-150173-01 extension arm
- Four M6 screws
- Four M6 hex-head screws
- One access point

About This Task

Install your access point with an extension arm if a standoff distance—but no tilt—is required. The KT-150173-01 extension arm provides a minimum standoff distance of twelve inches and helps avoid interference with the antennas.

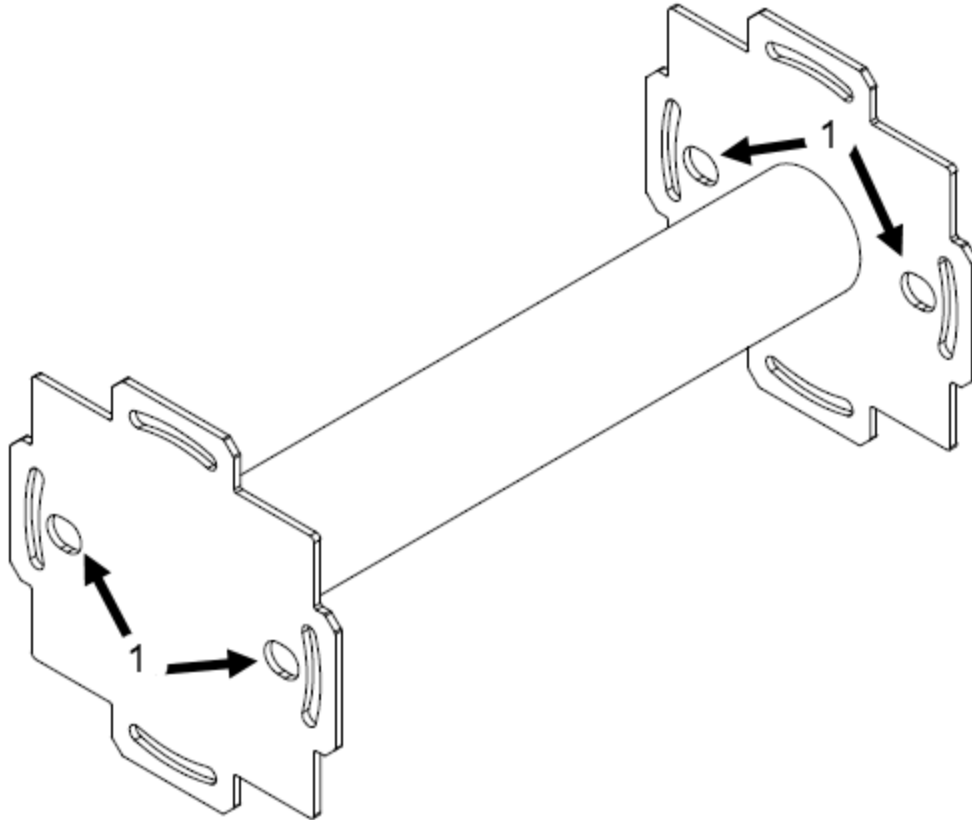

Figure 7: KT-1501730-01 Extension Arm Attachment Holes

Callout	Description
1	Extension arm attachment holes

Procedure

1. Using the KT-150173-01 extension arm as a template, mark and drill four hole centers on a flat surface.
The holes must be within the circular cuts in the end of the flange. See the diagram above.
2. Attach one end of the KT-150173-01 extension arm to the access point using four M6 screws.
3. Attach the other end of the KT-150173-01 extension arm to the wall using four M6 hex-head screws.
Use screw-in anchors with the four M6 hex-head screws when you mount the bracket on a wood surface and use concrete anchors for concrete surface.

Install the Access Point on a Wall With the MBO-ART03 Bracket

Before You Begin

Obtain the items in the following table.

Table 17: Hardware requirements for MBO-ART03 articulating mounting bracket wall installation

Quantity	Item
1	Access point
1	MBO-ART03 articulating mounting bracket
6	M6 hex-head screws Two M6 hex-head screws for attaching the bracket and the access point. Four M6 hex-head screws for attaching the bracket to the wall.
2	Long M6 hex screws and nuts to lock each axis.

You also need a torque wrench and tool that matches the nuts for the M6 hex screws.

About This Task

Install the access point to a wall so it is secure and your customers can easily access your wireless network.

Procedure

1. Mark and drill four holes on the wall.
It is recommended that you use one of the bracket ends as a template. You can remove the end from the bracket.
2. Adjust the arm length.
The arm is set to a 7.5-inch extension. To increase it to a 9-inch extension, you move 1 pivot and lock screw to the outside holes on 1 bracket. To increase the extension to 10.5-inches, move both pivot and lock scerw pairs to the outside holes on each bracket
3. Attach the bracket to the access point with the M6 hex-head screws.
4. Align the bracket mounting holes with the holes on the wall.
5. Attach the bracket to the wall with the M6 hex-head screws.
6. Insert the locking bolts into the bracket and arm locking hole.
7. Attach the nuts and torque to 45 inch-pounds.
8. Tighten the pivot screws and nuts to 60 inch-pounds.

Install the Access Point on a Wall Using MBO-ART02 Articulating Mounting Bracket

Before You Begin



Note

The MBO-ART02 wall mount bracket is End of Sale (EOS) as of January, 2023. It is replaced by the MBO-ART03 bracket.

Obtain the items listed in the following table.

Table 18: Hardware Requirements for MBO-ART02 Articulating Mounting Bracket Wall Installation

Quantity	Item
1	Access point
1	MBO-ART02 articulating mounting bracket
4	M6 hex-head screws Two M6 hex-head screws to attach the MBO-ART02 to the access point. Four M6 hex-head screws to attach the MBO-ART02 bracket to the wall.

About This Task

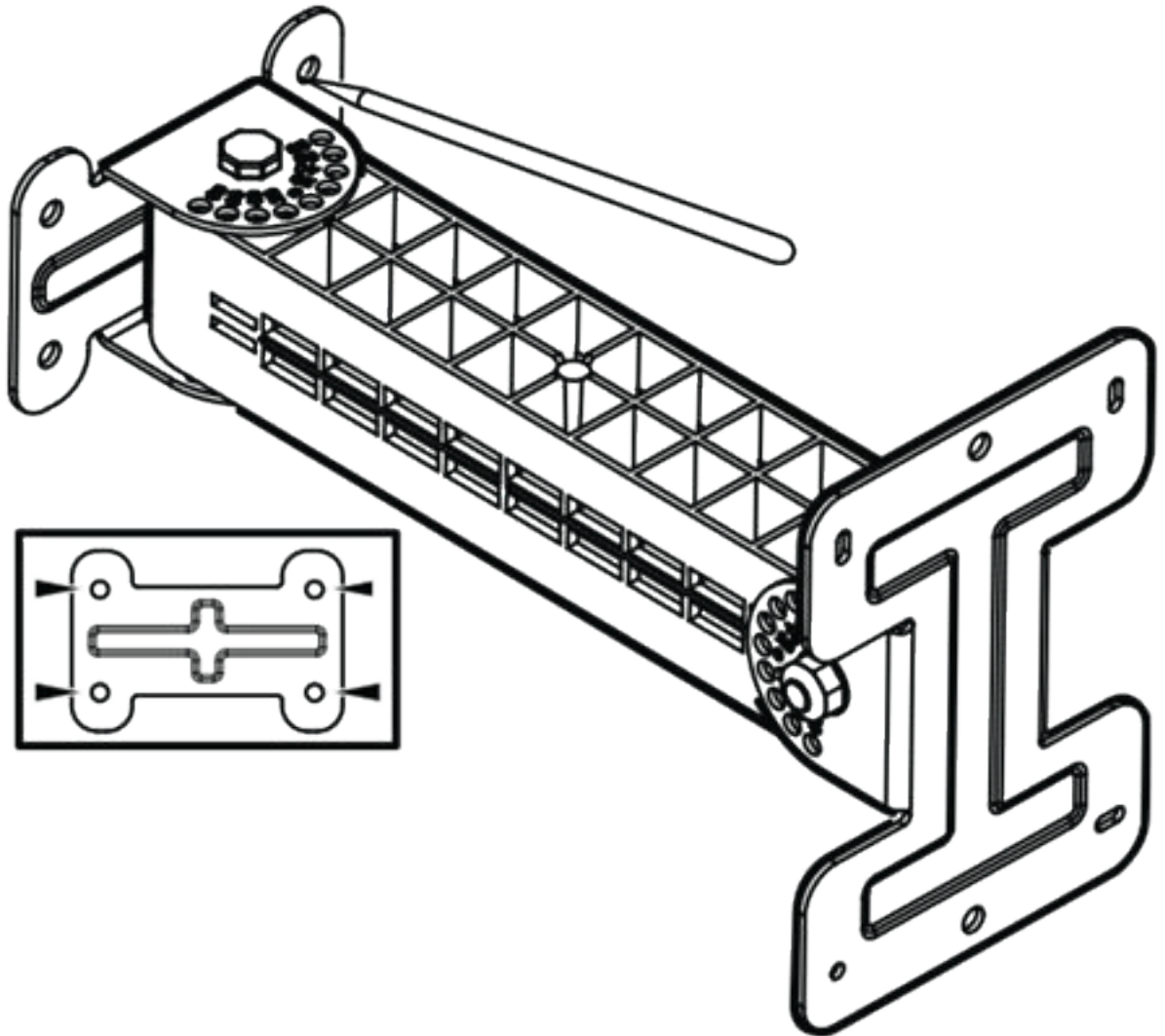

Figure 8: MBO-ART02 Bracket Template for Attachment Holes

The MBO-ART02 bracket is for outdoor use when you require a bracket with +/- 80-degree that can be adjusted in 20-degree increments. It also has a 2-axis tilt and 10-inch extension.

Procedure

1. Using of the MBO-ART02 articulating mounting bracket's end as a template, mark and drill two holes on the wall.
2. Align the mounting holes on the MBO-ART02 articulating mounting bracket against the holes on the wall and attach the bracket using four M6 hex-head screws.
3. Attach the MBO-ART02 to the access point using two M6 hex-head screws.

Install the Access Point on a Wall Using ACC-MBO-KT-AX Adapter and MBO-ART03 Articulating Mounting Bracket

Use the MBO-ART03 articulating mounting bracket with the ACC-MBO-KT-AX Adapter for wall installations.

About This Task



Note

This task only applies to the AP460C, AP460G, AP460S6C and AP460S12C.

The following hardware is required for outdoor access point wall installation using the -MBO adapter and MBO-ART03 articulating mounting bracket:

- One outdoor access point
- One ACC-MBO-KT-AX adapter
- Two M5 hex bolts
- One MBO-ART03 articulating mounting bracket
- Four M6 hex-head screws

In addition, you need a torque wrench, a drill and a carpenter's pencil or a pen.

Attach the access point to a wall using the -MBO adapter with the MBO-ART03 articulating mounting bracket.



Note

When using the MBO-ART03 articulating mounting bracket, set the maximum downward tilt to less than 20 degrees to prevent water ingress.

Procedure

1. Attach the ACC-MBO-KT-AX adapter to the access point using the two M5 bolts.
2. Torque the M5 bolts to 25 in-lbs.
3. Use the MBO-ART03 articulating mounting bracket as a template, mark and drill two holes on the wall.
4. Attach the larger face plate end of the MBO-ART03 mounting bracket to the ACC-MBO-KT-AX adapter using two M6 hex-head screws.
5. Align the mounting holes on the ART03 bracket against the holes on the wall.
6. Attach the ART03 bracket to the wall using two M6 hex-head screws.

Install the Access Point on a Pole

Before You Begin

The access point is used with the KT-147407-02 bracket parts and KT-150173-01 extension arm for pole installation. The access point is mounted on a pole by attaching:

1. All three parts of the KT-147407-02 bracket.
2. The KT-150173-01 extension arm with all the KT-147407-02 bracket parts.
3. The pole bracket part of the KT-147407-02 bracket.
4. The KT-150173-01 extension arm with the pole part of the KT-147407-02 bracket.

The following hardware is required to install the access point on a pole:

- All parts of the KT-147407-02 bracket
- Six M6 screws
- Two hex-head M12 stainless-steel screws
- Two hex-heads M12 stainless-steel nuts
- 0.5 in. wide stainless-steel cable clamps
- KT-150173-01 extension arm

**Note**

You must provide M6 hex-head screws and screw-in anchors.

**Note**

The cable glands must face down when you install the access point on a pole.

Install the Access Point on a Pole Using KT-147407-02 Bracket Parts

Before You Begin

The following hardware is required for pole installation using KT-147407-02 bracket parts:

- All parts of the KT-147407-02 bracket
- Four M6 screws
- Two hex-head M12 stainless-steel screws
- Two hex-head M12 stainless-steel nuts
- Two 0.5 in. wide stainless-steel cable clamps
- One access point

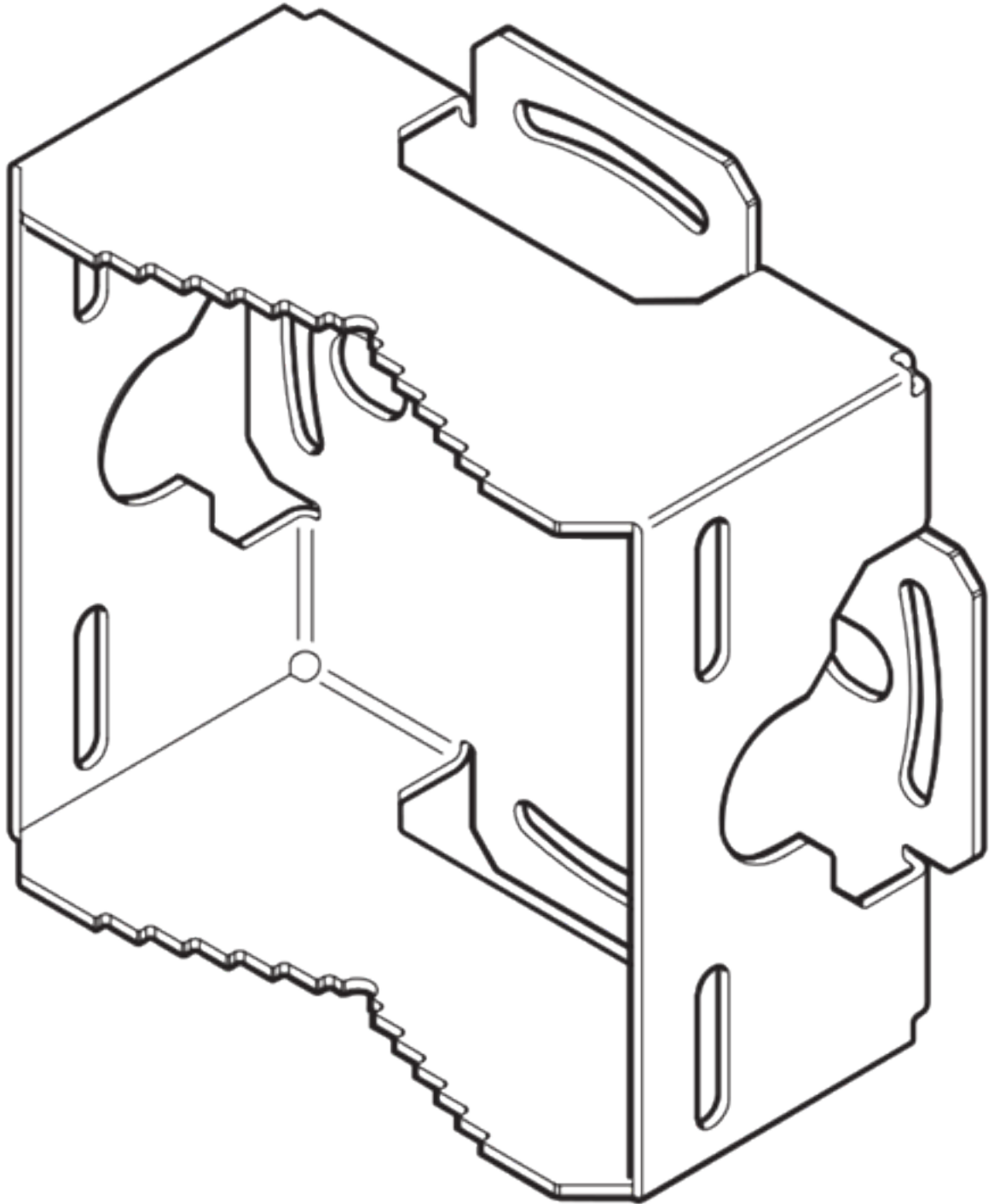

Figure 9: Pole part of the KT-147407-02 bracket

About This Task

Use the following information to install the Access Point on a pole with the KT-147407-02 Bracket.

Procedure

1. Attach the KT-147407-02 flat part and 1-axis tilt part to the access point.
For instructions on how to attach the bracket parts, see [Install the Access Point Using KT-147407-02 Bracket Parts and KT-150173-01 Extension Arm](#) on page 26.
2. Attach the KT-147407-02 pole part to the 1-axis tilt bracket using two M12 bolts through the large bracket holes on the 1-axis tilt bracket and the pole bracket.
3. Fasten the bolts using two M12 hex nuts.

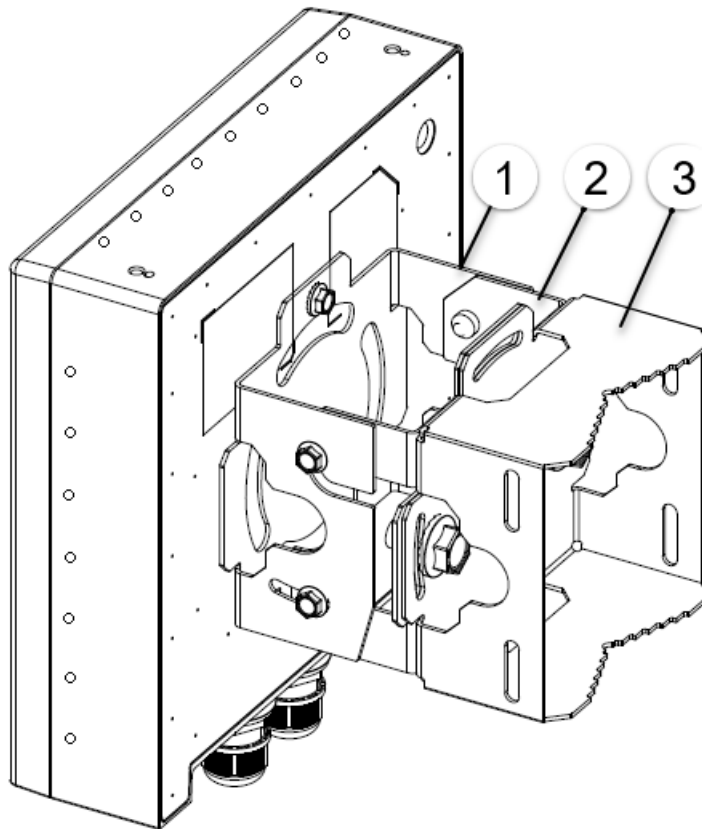

Figure 10: AP5050U access point with KT-147407-02 bracket parts

Callout	Description
1	Flat part of the KT-147407-02 bracket, with two holes on the metal surface
2	1-axis tilt bracket, with large holes on the surface
3	Pole bracket

4. Insert the stainless-steel cable clamp through the long slots on the pole bracket.
5. Position the cable clamps on the pole bracket around a pole and attach the pole bracket
6. Insert the ends of the cable clamps around the pole and tighten the clamp screws to a torque of 11 in-lbs.

Install the Access Point on a Pole with the MBO-ART03 and KT-147407-02 Brackets

Before You Begin

The following hardware is required to install your access point to a pole with the MBO-ART03 and KT-147407-02 brackets.

Table 19: Hardware Requirements

Quantity	Item
1	Access point.
1	KT-147407-02 bracket.
1	MBO-ART03 articulating mounting bracket.
2	M6 hex-head screws to attach the MBO-ART03 to the access point.
2	M6 screws with nuts and washers to attach KT-147407-02 to the MBO-ART03.
2	Long M6 Hex hex screws and nuts for providing an angular lock for each axis.
2	Cable clamps with a band of 0.5 in. (12.7 mm). Cable clamps must be purchased separately as they are not included.
1	Torque wrench with sockets.
1	Flat head screwdriver.

About This Task

You can install your access point to a pole if you do not want to drill into a concrete wall. With a pole, the access point coverage area can be greater because a pole is often higher than a wall.

Procedure

1. Attach the KT-147407-02 to the MBO-ART03 with two M6 screws, nuts, and washers.
2. Attach both cable clamps to the KT-147407-02 bracket.
You open the cable clamp by inserting the head of the flathead screwdriver into the retaining screw and turning the screw counterclockwise. Then insert the nonclamp end into the KT-147407-02 through the holes.
3. Attach the two brackets to the pole.
4. Tighten the cable clamp screw around the pole by turning the screws clockwise with a flathead screwdriver.
5. Attach the access point to the MBO-ART03 with two M6 hex-head screws.
6. Adjust the two pivot points until you are satisfied.
7. Insert the locking bolts into the bracket and arm locking hole.
8. Attach the nuts and torque to 45 inch-pounds.
9. Tighten the pivot screws and nuts to 60 inch-pounds.
10. Attach the safety hanger strap as per the local code.

11. Adjust the LAN cable so the access point glands have a drip loop in each cable.
The LAN cable must be located on the lower side for AP460i/e, AP560i, AP560h, AP5050D and AP5050U

Install the Access Point on a Pole Using KT-147407-02 Bracket Parts and KT-150173-01 Extension Arm

Before You Begin

The following hardware is required for pole installation using KT-147407-02 bracket parts and KT-150173-01 extension arm:

- All parts of the KT-147407-02 bracket
- KT-150173-01 extension arm
- Six M6 screws
- Four hex-head M12 stainless-steel screws
- Four hex-head M12 stainless-steel nuts
- Two 0.5" wide stainless-steel cable clamps
- One access point

About This Task

Install the access point on a pole with all three KT-147407-02 bracket parts and KT-150173-01 extension arm

Procedure

1. Attach the flat part and the 1-axis tilt part of the KT-147407-02 bracket to the access point.
For instructions on how to attach the bracket parts, see [Install the Access Point Using KT-147407-02 Bracket Parts and KT-150173-01 Extension Arm](#) on page 26.
2. Align the circular holes on one end of the KT-150173-01 extension arm against the large holes on the 1-axis tilt bracket.
3. Attach the KT-150173-01 extension arm to the 1-axis tilt bracket by using two hex-head M12 stainless-steel screws and two hex-head M12 stainless-steel nuts.

4. Attach the KT-147407-02 pole part to the other end of the KT-150173-01 extension arm using two M12 screws and M12 hex-nuts.

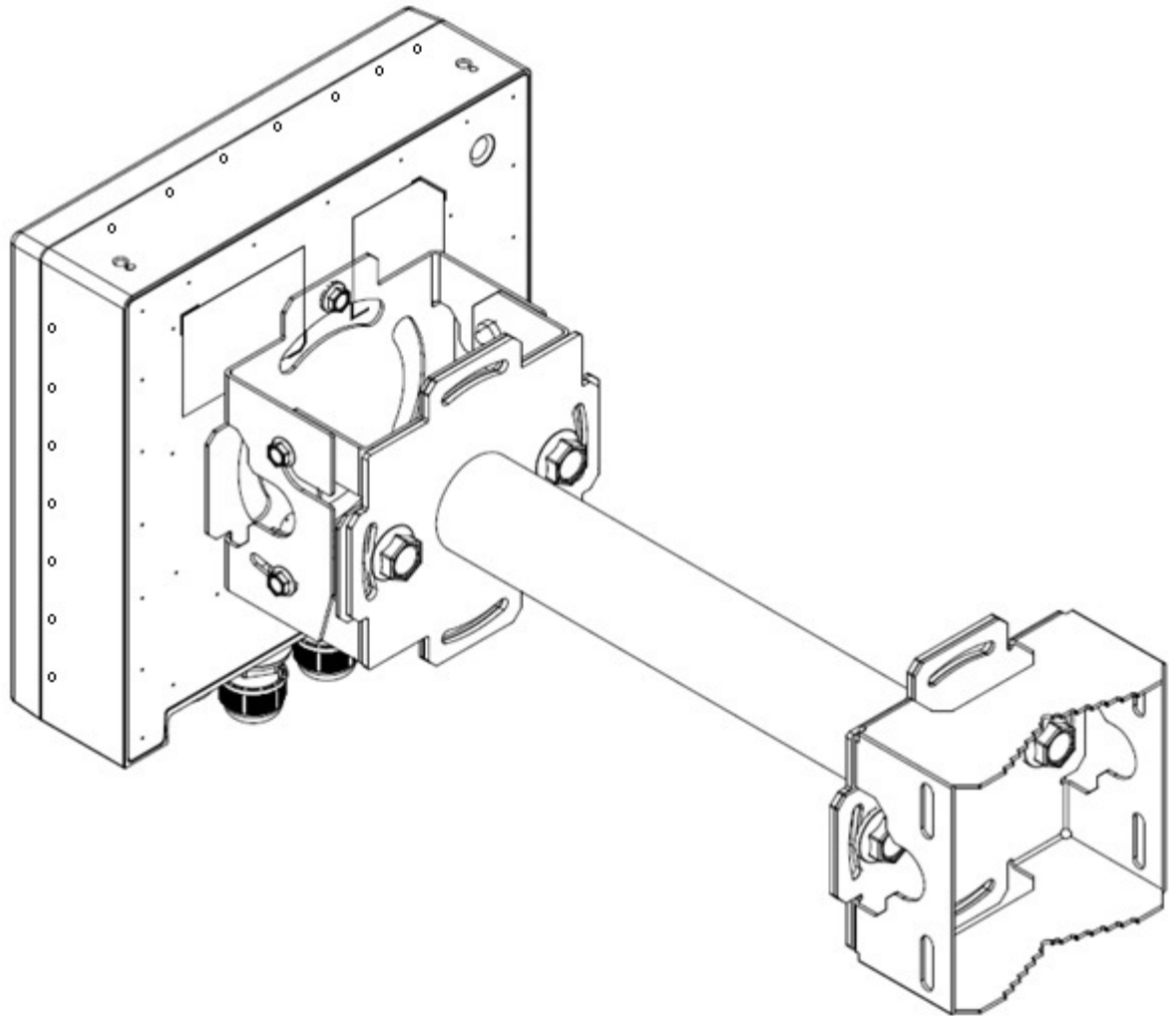

Figure 11: Attaching the KT-150173-01 extension arm to the 1-axis tilt part of the KT-147407-02 bracket

5. Insert 0.5 in. stainless-steel cable clamps through the KT-147407-02 pole part long slots.
6. Position the cable clamps around a pole and attach the pole bracket to a pole.
7. Insert the ends of the cable clamps around the pole and tighten the clamp screws to a torque of 11 in-lbs.

Mount the Access Point to a Pole using the Pole Part of the KT-147407-02 Bracket

Before You Begin

The following hardware is required for pole installation using KT-147407-02 pole bracket part to the access point:

- Pole part of the KT-147407-02 bracket
- Four M6 screws

- Two 0.5 in. wide stainless-steel cable clamps
- One access point

About This Task

The pole part of the KT-147407-02 bracket is attached to the access point for pole installation. To mount the access point to a pole using the KT-147407-02 pole bracket part:

Procedure

1. Attach the pole part of the KT-147407-02 bracket to the access point using four M6 screws.
Align the four hinges of the pole part of the KT-147407-02 bracket against the holes on the access point to attach the M6 screws.
2. Attach the pole bracket to a pole by following steps 5, 6, and 7 in [Install the Access Point Using KT-147407-02 Bracket Parts and KT-150173-01 Extension Arm](#) on page 26.

Mount the Access Point to a Pole using the Pole Part of the KT-147407-02 Bracket and the KT-150173-01 Extension Arm

Before You Begin

The following hardware is required for pole installation using KT-147407-02 pole bracket part and the KT-150173-01 extension arm:

- Pole part of the KT-147407-02 bracket
- KT-150173-01 extension arm
- Four M6 screws
- Two hex-head M12 stainless-steel screws
- Two hex-head M12 stainless-steel nuts
- Two 0.5 in. wide stainless-steel cable clamps
- One access point

About This Task

The extension arm is used with the pole part of the KT-147407-02 bracket on the access point for pole installation. To mount the access point to a pole using the KT-147407-02 pole bracket part and the KT-150173-01 extension arm:

Procedure

1. Attach the KT-150173-01 extension arm to the access point using two M6 screws.
2. Attach the pole bracket part of the KT-147407-02 bracket to the other end of the KT-150173-01 bracket using two hex-head M12 stainless-steel screws and two hex-head M12 stainless-steel nuts.
3. Attach the pole bracket to a pole by following steps 5, 6, and 7 in [Install the Access Point Using KT-147407-02 Bracket Parts and KT-150173-01 Extension Arm](#) on page 26.

Install the Access Point on a Pole Using MBO-ART02 Articulating Mounting Bracket and POLE01 Bracket

About This Task



Note

The MBO-ART02 wall mount bracket is End of Sale (EOS) as of January, 2023. It is replaced by the MBO-ART03 bracket.

The WS-MBO-POLE01 bracket is End of Sale (EOS) as of January, 2023.

For more information, see [End of Sale and End Service Life](#).

Attach the access point to a pole using the WS-MBO-POLE01 bracket on MBO-ART02 articulating mounting bracket.

Table 20: Hardware requirements for pole installation

Quantity	Item
1	Access point
1	MBO-ART02 articulating mounting bracket
2	M6 hex-head screws to attach the MBO-ART02 to the access point
1	WS-MBO-POLE01 bracket
4	M3 screws with nuts and washers to attach the WS-MBO-POLE01 bracket to the MBO-ART02 articulating mounting bracket
2	Cable clamps



Note

You must provide stainless-steel cable clamps. The band must be 0.5 in. (12.7 mm) wide.

Procedure

1. Attach the MBO-ART02 articulating mounting bracket to the access point using two M6 hex-head screws.

2. Attach the WS-MBO-POLE01 bracket to the MBO-ART02 articulating mounting bracket using four M3 screws, nuts, and washers.

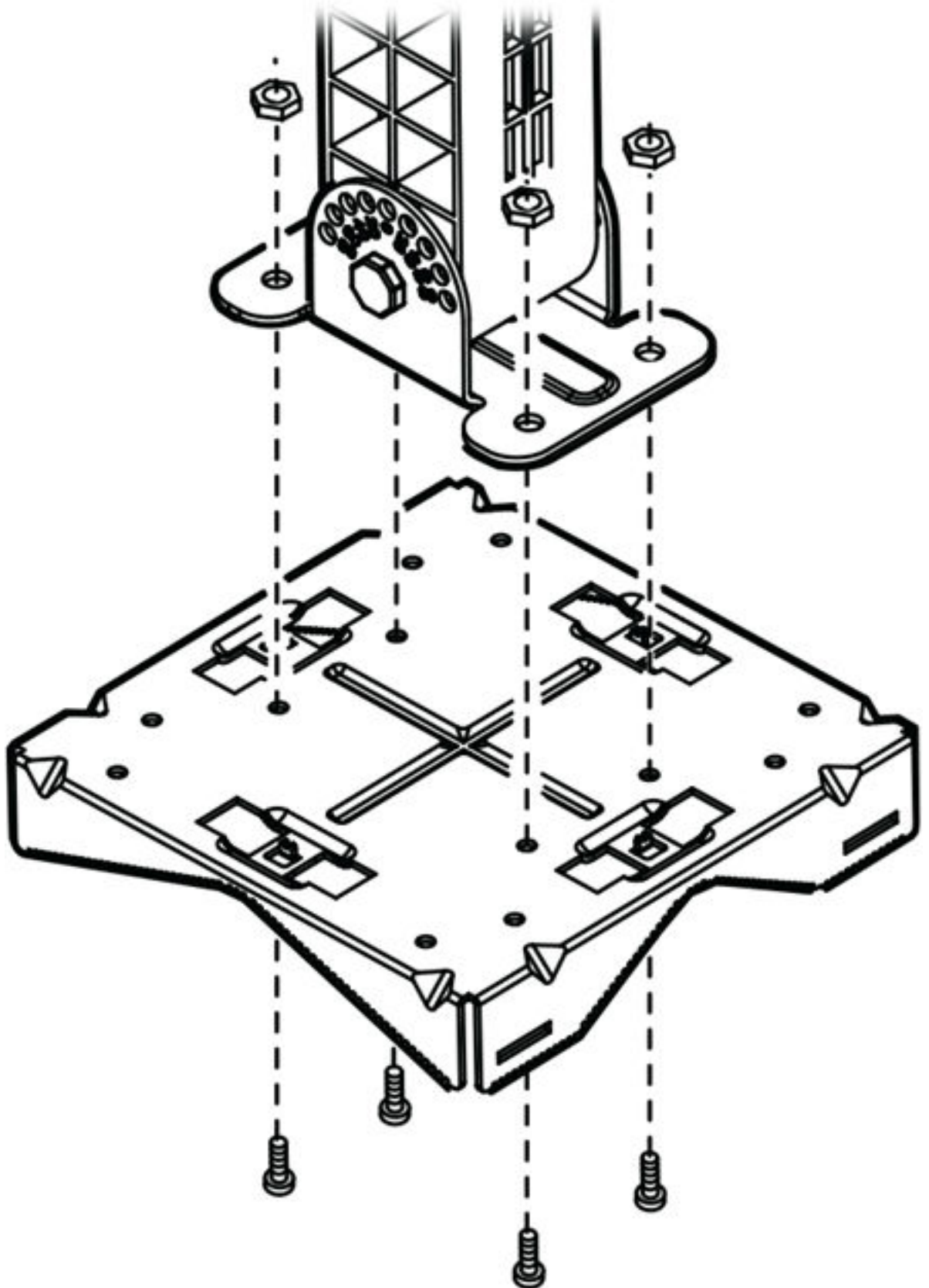

3. Attach both the cable clamps to the WS-MBO-POLE01 bracket.
Open the cable clamp by turning a flat bladed screwdriver counterclockwise. Then insert the non-clamp end into the pole bracket through the holes.
4. Put the metal band around the pole and attach the WS-MBO-POLE01 bracket to the pole.
5. Tighten the cable clamp screw clockwise, tightening the band around the pole.

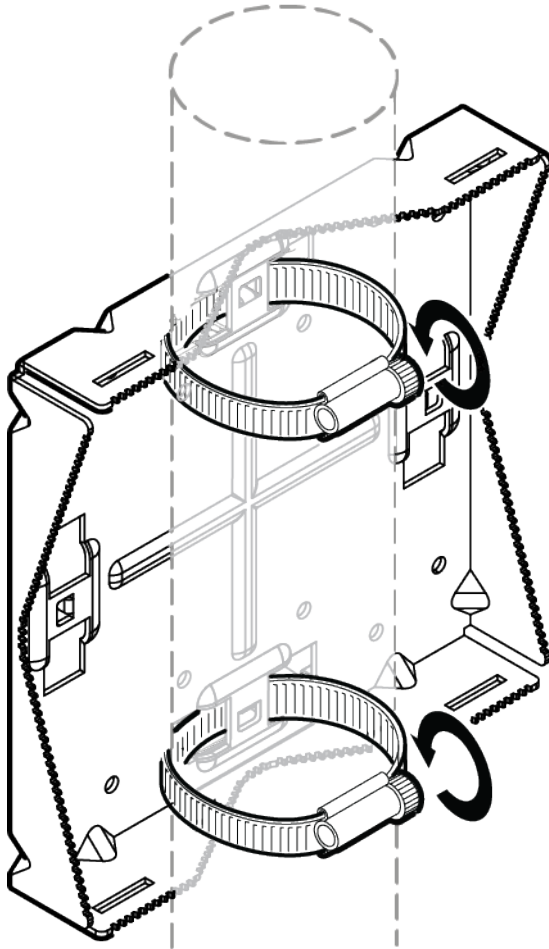

Figure 12: Tightening the cable clamps on the POLE01 bracket

Install the Access Point on a Unistrut Structure Using the MBO-ART03 Bracket

Before You Begin

The following hardware is required to install the MBO-ART03 bracket on a Unistrut structure:

- One MBO-ART03 bracket

The MBO-ART03 bracket ships with the following hardware:

- Two long screws
- Four short screws

- Four nuts

**Note**

For Unistrut installations, discard two of the short screws and nuts. Provide two M12 stainless steel bolts, hex nuts, and split washers.

About This Task

The MBO-ART03 bracket has +/- 80-degree (in 10-degree increments) 2-axis tilt and variable 7 inches to 10 inches extension. The bracket comes installed with M6 pivot screws.

It can be used on a wall, unistrut bracket or pole.

On the MBO-ART03 bracket's flat surface, there are three large holes for interfacing with the Unistrut metal frame. There are two smaller holes for M6 bolts for mounting to the KT brackets or a wall also. Each metal bracket on either end of the ART03 bracket has two bent sections with two pivot holes and serrated lock positions.

The length on the bent sections can be adjusted, if desired. Move the pivot points to increase the MBO-ART03 bracket's extension lengths to 7.5 in. to 9.0 in., or 10.5 in.

To adjust the MBO-ART03 bracket's extension:

1. Remove the pivot screw and nut.
2. Move the MBO-ART03 bracket arm's center hole to the other pivot hole on the bracket.
3. Insert the pivot screw through the bracket and the arm.
4. Attach the pivot nut to the screw.

Use a crescent wrench or a 13 mm tool to tighten the pivot screws and nuts.

5. Torque the screws and nuts to finger tightness.

Adjust the MBO-ART03 bracket's angular position

1. The horizontal and vertical adjustments can be made in 10 degree increments.

The increments are marked on the MBO-ART03 bracket.

**Note**

The access point glands should point downward to prevent water entry.

2. Rotate the arm to the desired position.
3. When the lock screw hole lines up with the appropriate serrated screw hole, insert the long M6 screw and fasten with a hex nut.
4. Torque the lock screws and nuts to 45 inch-lbs.
5. Torque the pivot screws and nuts to 60 inch-lbs.

The left to right adjustment can be made to any angle, with the access point having at least 1 in. clearance from another object.

**Tip**

The best practice is to make the vertical adjustment before attaching the access point to the MBO-ART03 bracket.

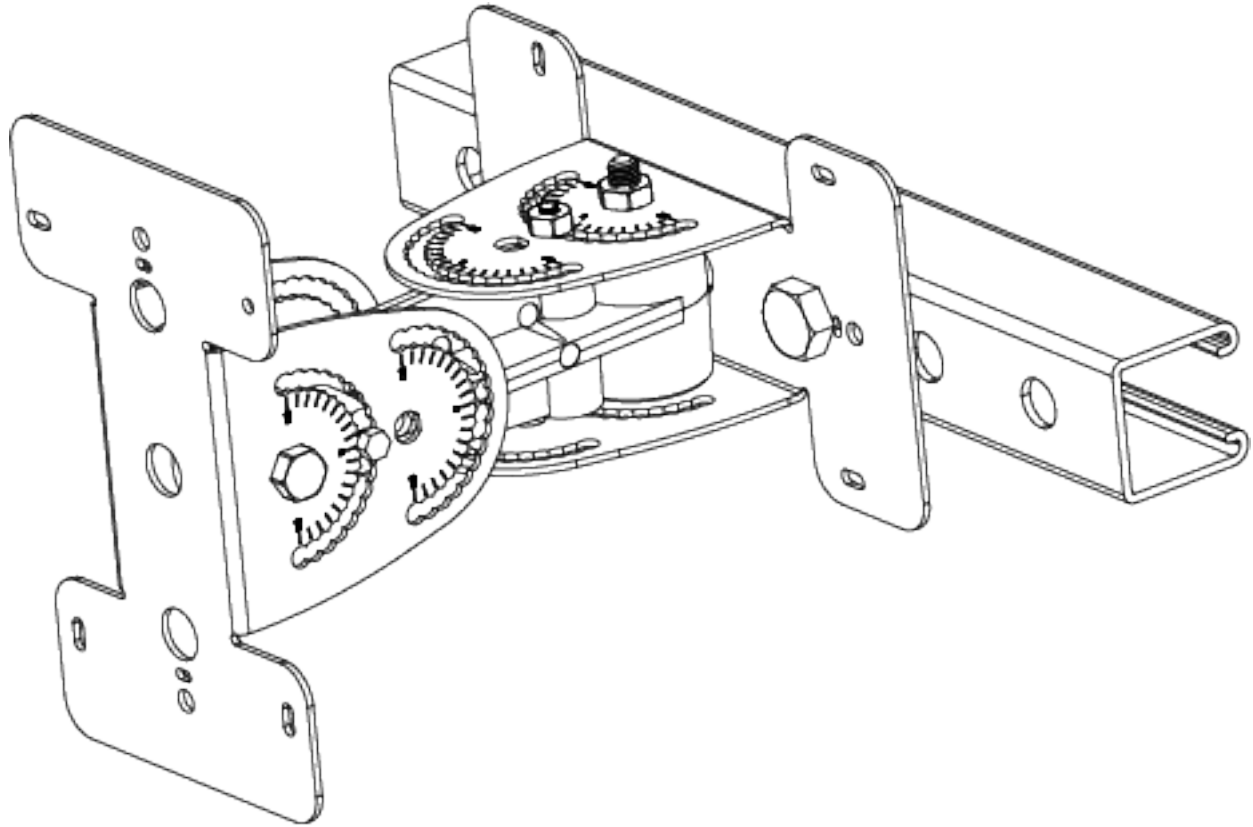

Figure 13: MBO-ART03 bracket angular adjustments

Install the Plastic Service Panel on the Access Point

About This Task

A service panel must be installed when the access point is installed under-bench or on a riser.

When a service panel is installed on an access point that is mounted on a riser, the service panel bottom must be closed. Keeping the service panel bottom open will enable debris to fill up, that can shorten the life of the service panel.

**Note**

The service panel bottom opening must be closed and glued in place when not needed. The openings can be covered with at least 0.050 inches thick plastic or metal coverings.

**Tip**

The best practice is to use one part clear super glue and two parts epoxy to hold the service panel cover in place. This helps provide some resistance during pressure washing.

**Note**

When installing the access point flat against a surface in a location that uses ice melt, the best practice is to apply an anti-seize material to the screws before attaching them to the access point metal base.

Procedure

1. Attach the plastic service panel base to the access point using four, 75 mm service panel shoulder screws.

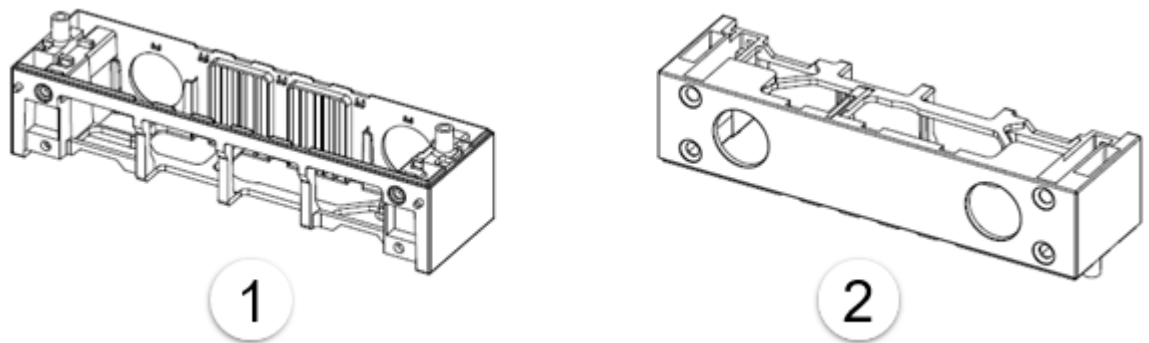

Figure 14: Plastic service panel base views

Callout	Description
1	Plastic service panel base
2	Side view of plastic service panel base

2. Torque the screws to 13 in-lbs.

- Place the service panel top over the service panel base and lock it into place using the captive screw.



Figure 15: Plastic service panel top captive screw

Callout	Description
1	Plastic service panel top captive screw

- Torque the screws to 4 1/2 in-lbs.

Secure the Access Point after Installation

Details about installing a security cable on the access point after installation.

Before You Begin

The following hardware must be supplied by the user for safety cable installation:

- A 3 mm diameter security cable
- Lock to secure the ends of the security cable

About This Task

You can secure the access point to the mounting environment using a 3 mm diameter safety cable. The safety cable is used to enhance the physical security of the access point after installation.

Procedure

- Insert the safety cable through the security cable hole on the metal base of the access point.

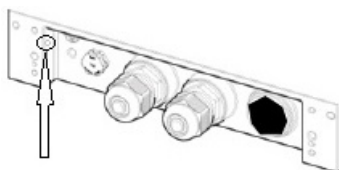

Figure 16: Security cable hole on the access point

- Push the cable through the security hole until you see it come out on the other side of the metal base.

3. Insert a lock through the looped ends of the cable and lock it in place.

Power or Pressure Washing Guidelines

Details about how to safely pressure wash the surface around the access point.

Before You Begin

Ensure that your pressure washing equipment fulfills the following specifications:

- Pressure washer Pounds per Square Inch (PSI) must be less than 4000.
- Do not use a nozzle with less than 15-degree washer tip.
- The pressure washing nozzle must be at least 24 in. away from the access point.

Cleaning solution specifications:

- Use only commercially available cleaning agents and solvents to clean the access point.
- Use only commercially available ice-melt products.



Warning

Do not use cleaning agents, solvents, and ice-melt products that are flammable, contain polycarbonate or rubber dissolving ingredients, uses refined petrochemical materials, and any other materials that can damage a concrete surface.



Note

Do not use the power washing equipment near power lines.



Note

Wear safety goggles with complete eye protection when using the power washing equipment.

About This Task

You can pressure wash the access point and the surface under a seat or a slope around the access point to remove dirt and debris.



Tip

The best practice is to follow the pressure washing guidelines for longevity of the access point parts.

Procedure

1. Use a prescribed pressure washing nozzle to wash the access point and the surface around it
2. Keep the pressure washing nozzle at least 24 in. away from the access point.



Ground the Access Point

Learn how to safely ground the access point.

About This Task

Ground the outdoor access point for outdoor installations. A ground terminal is provided for lightning protection. Ground connection is not required for under seat or indoor deployments. The ground connector on the access point is not a protective earth ground. To add ground connection to the access point: Attach the ring terminal to the ground wire. Insert the ring terminal on the ground screw. Thread the ground screw into the access point hole below the ground symbol.

To add ground connection to the access point:

Procedure

1. Attach the ring terminal to the ground wire.
2. Insert the ring terminal on the ground screw.
3. Thread the ground screw into the access point hole below the ground symbol.

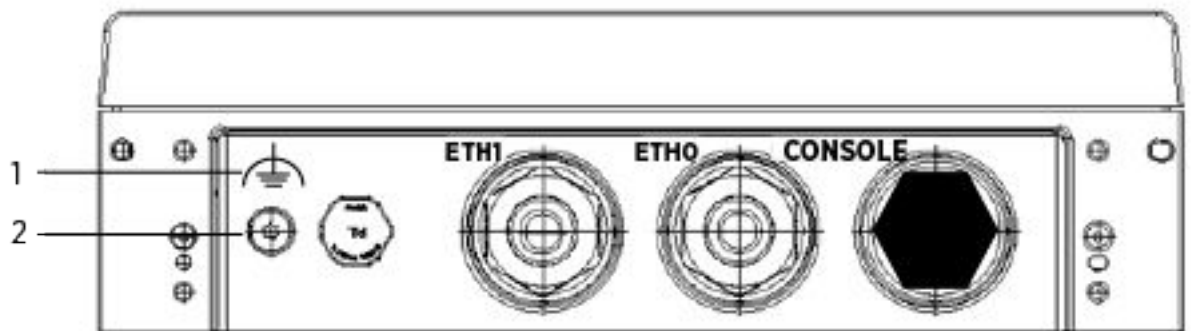

Figure 17: Ground port hole

Callout	Description
1	Ground symbol
2	Ground screw hole

4. Tighten the ground screw to 12 in-lbs.



Connect the ETH1 or ETH0 Cable through the Service Panel Base

The ETH1 or ETH0 cable can be connected through the front or the rear hole on the side of the service panel base

About This Task

The ETH1 or ETH0 cable is connected through the side or bottom holes on the service panel base.

The following hardware is required to attach the ETH1 or ETH0 cable through a hole on the service panel base:

- ETH1 or ETH0 cable
- One blank conduit cover to cover the front hole on the side of the service panel base
- One 3/4 in. or 1/2 in. conduit cover, depending on the circumference of the ETH1 or ETH0 conduit
- Service panel base
- Service panel top
- ACC-CAT6-LAN-GSKT
- RJ-45 Plugs
- Four flat head long M4 screws to hold the service panel to the access point

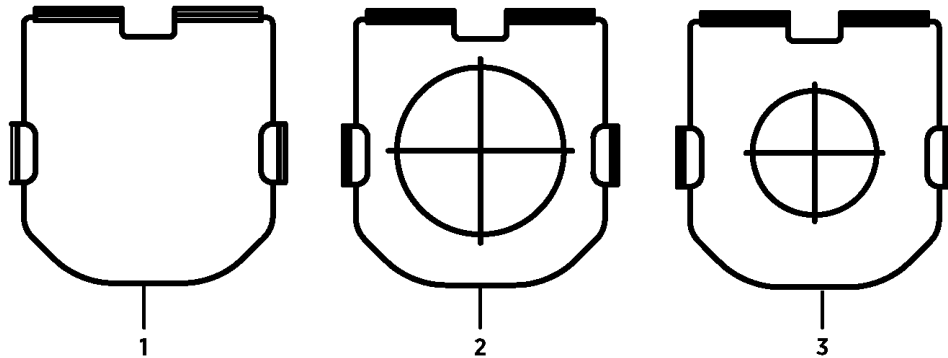

Figure 18: Metal conduit covers

Callout	Description
1	Blank conduit cover to cover the front hole on the side of the service panel base
2	$\frac{3}{4}$ in. conduit cover
3	$\frac{1}{2}$ in. conduit cover

Procedure

1. Using the blank conduit cover, cover the front hole of the service panel base
2. Attach either the $\frac{1}{2}$ in. conduit cover or the $\frac{3}{4}$ in. conduit cover to the rear hole of the service panel base.
3. Bring in the ETH1 or ETH0 cable, and the ground wire through the rear side hole of the service panel base.
4. Loosely align the service panel base next to the metal sloping bracket, thereby leaving enough space to attach the ETH1 or ETH0 cable to the access point.
5. Attach the ground wire to the access point.
6. Remove the gland caps, plastic cage, and the gasket from the ETH0 port.



Note

Put the removed parts onto the LAN cable to be attached to the access point later.

7. Connect the ETH0 LAN cable through the ETH0 gland port until it clicks into place in the GE1 port.

If there is a ETH1 connection, insert the cable through the ETH1 gland until it locks into place in to the GE2 port.

8. Torque the gland cap to 12-in lbs.
9. Fold and arrange the ETH0 cable into the gap of the metal sloping bracket and the service panel base.

The ETH0 cable must not be bent sharply and must have 1 in. bend radius.



Connect the ETH1 or ETH0 Cable to the Access Point

Learn how to connect the ETH1 or ETH0 cable to a conduit hole on the metal sloping bracket.

About This Task

The following hardware is required to attach the ETH1 or ETH0 cable through a conduit hole:

- ETH1 or ETH0 cable
- Two blank conduit covers to cover the front and the rear holes on the side of the service panel base

Callout	Description
1	Large conduit hole on the metal sloping bracket

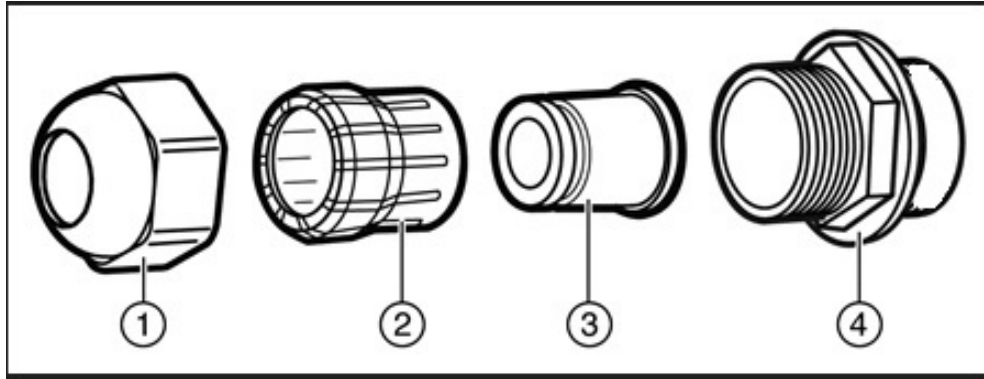

Figure 19: Cable Glands

Table 21: Cable Gland Descriptions

Number	Item	Description
1	Gland cap	Compresses the gland gasket and provides a water seal around the LAN cable when you insert a LAN cable into the access point. This part is removeable.
2	Gland cage	The gland cap pushes against the gland cage and compresses the LAN cable gasket. This part is removeable. Note that the cage has a slit for fitting the cage around the gasket. The non-separated end goes against the flat edge of the gasket.
3	Gland LAN cable gasket	The gasket has a slit for fitting the gasket around the LAN cable. It compresses around the cable and against the gland body so there is an IP67 or water seal around the cable. This gasket is removeable. Note: The acces point ships with two types of LAN cable gaskets - gray gaskets and black gaskets: <ul style="list-style-type: none"> • If the LAN cable is CAT5 or CAT5E then use the gray LAN cable gasket that is on the gland • If the LAN cable is CAT6 or CAT6A then use the black LAN cable gaskets that shipped in the bag marked ACC-CAT6-LAN-GSKT.
4	Gland body	Provides a IP67 or water seal to the access point. Note: Do not touch the gland body as you can damage it.

Procedure

1. Bring in the ETH1 or ETH0 cable through the conduit hole.
2. Remove the gland cap, plastic cage, and the gasket from the ETH1 port.



Note

Put the removed parts onto the LAN cable to be attached to the access point later.

3. Connect the ETH0 LAN cable through the ETH0 port until it clicks into place.
If there is a ETH1 connection, insert the cable through the ETH1 gland until it locks into place into the ETH1 port.
4. Torque the gland cap to 12-in lbs.
5. Fold and arrange the ETH0 cable into the gap of the metal sloping bracket and the service panel base.
6. Snap-on the Service Panel cover
7. Tighten the single screw on the service panel cover - do not strip the screw.



Regulatory and Compliance Information

- [Safety Guidelines](#) on page 55
- [Professional Installation Instruction](#) on page 56
- [FCC Notice \(Part 15 - Class B\)](#) on page 56
- [FCC Radiation Exposure Statement](#) on page 57
- [Industry Canada Notice](#) on page 58
- [Mexico Compliance Statement](#) on page 59
- [Brazil Agência Nacional De Telecomunicações \(Anatel\) Statement](#) on page 60
- [Taiwan Regulatory Statement](#) on page 60
- [Thailand Regulatory Statement](#) on page 61
- [United Kingdom \(UK\) and European Union \(EU\) Radiation Warning Statement](#) on page 62
- [Extreme Networks UK Address](#) on page 63
- [Extreme Networks EU Importer Address](#) on page 63
- [European Waste Electrical and Electronic Equipment \(WEEE\) Notice](#) on page 63
- [Declaration of Conformity in Languages of the European Community](#) on page 63

Learn about safety guidelines, compliance notices, and regulatory information pertaining to various countries in which the device can be used.

Safety Guidelines

The following safety guidelines are intended to protect your personal safety and prevent damage to the equipment.



Important

Only qualified personnel must perform installation procedures. Within the context of the safety notes in this documentation, qualified persons are defined as persons who are authorized to commission grounding, label devices, systems, and circuits in accordance with established safety practices and standards. A qualified person understands the requirements and risks involved with installing outdoor electrical equipment in accordance with national codes.

Professional Installation Instruction

Installation personnel

This product is designed for specific application and needs to be installed by a qualified personnel who has RF and related rule knowledge. The general user shall not attempt to install or change the setting.

Instructions d'installation professionnelle

Installation

Ce produit est destiné à un usage spécifique et doit être installé par un personnel qualifié maîtrisant les radiofréquences et les règles s'y rapportant. L'installation et les réglages ne doivent pas être modifiés par l'utilisateur final.

Procédure d'installation

Consulter le manuel d'utilisation.



Warning

Avertissement: Choisir avec soin la position d'installation et s'assurer que la puissance de sortie ne dépasse pas les limites en vigueur. La violation de cette règle peut conduire à de sérieuses pénalités fédérales.

FCC Notice (Part 15 - Class B)

This device complies with Part 15 of the FCC rules. Operation is subject to the following two conditions: (1) this device may not cause harmful interference, and (2) this

device must accept any interference received, including interference that may cause undesired operation.

**Note**

This equipment has been tested and found to comply with the limits for a class B digital device, pursuant to Part 15 of the FCC rules. These limits are designed to provide reasonable protection against harmful interference when the equipment is operated in a commercial environment. This equipment uses, generates, and can radiate radio frequency energy and if not installed in accordance with the operator's manual, may cause harmful interference to radio communications. However, there is no guarantee that interference will not occur in a particular installation. If this equipment does cause harmful interference to radio or television reception, which can be determined by turning the equipment off and on, the user is encouraged to try to correct the interference by one of the following measures:

- Reorient or relocate the antenna of the receiving devices.
- Increase the separation between this equipment and receiving equipment.
- Connect this equipment into an outlet on a circuit different from that to which the receiving equipment is connected.
- Consult the dealer or an experienced radio or TV technician for help.

**Warning**

Changes or modifications made to this device which are not expressly approved by the party responsible for compliance could void the user's authority to operate the equipment.

For 5925-6425 MHz and 6525-6875 MHz transmitter operation in Standard power access point mode:

1. The operation of this device is prohibited on oil platforms, cars, trains, boats, and aircraft.
2. Operation of transmitters in the 5.925-7.125 GHz band is prohibited for control of or communications with unmanned aircraft systems.

FCC Radiation Exposure Statement

This transmitter must not be co-located or operating in conjunction with any other antenna or transmitter.

This device meets all the other requirements specified in Part 15C, Section 247 and Section 15.407 of the FCC Rules.

**Warning**

FCC Radiation Exposure Statement: This equipment complies with FCC radiation exposure limits set forth for an uncontrolled environment. This device has been tested and meets applicable limits for Radio Frequency (RF) exposure.

This device was tested with a separation distance of 51 cm. Always keep the device away from your body to ensure exposure levels remain at or below the tested levels.

Industry Canada Notice

This device contains licence-exempt transmitter(s)/receiver(s) that comply with Innovation, Science and Economic Development Canada's licence-exempt RSS(s). Operation is subject to the following two conditions:

- This device may not cause interference.
- This device must accept any interference, including interference that may cause undesired operation of the device.

Cet appareil contient des émetteurs / récepteurs exempts de licence qui sont conformes au (x) RSS (s) exemptés de licence d'Innovation, Sciences et Développement économique Canada. L'opération est soumise aux deux conditions suivantes:

- Cet appareil ne doit pas provoquer d'interférences.
- Cet appareil doit accepter toute interférence, y compris les interférences susceptibles de provoquer un fonctionnement indésirable de l'appareil.

For product available in the USA/Canada market, only channel 1~11 can be operated. Selection of other channels is not possible.

Pour les produits disponibles aux États-Unis / Canada du marché, seul le canal 1 à 11 peuvent être exploités. Sélection d'autres canaux n'est pas possible.

The device for operation in the band 5150–5250 MHz is only for indoor use to reduce the potential for harmful interference to co-channel mobile satellite systems.

les dispositifs fonctionnant dans la bande 5150-5250 MHz sont réservés uniquement pour une utilisation à l'intérieur afin de réduire les risques de brouillage préjudiciable aux systèmes de satellites mobiles utilisant les mêmes canaux.

**Warning**

This EUT is compliance with SAR for general population/uncontrolled exposure limits in IC RSS-102 and had been tested in accordance with the measurement methods and procedures specified in IEEE 1528.

**Warning**

IC Déclaration d'exposition aux radiations: Cet EUT est conforme au SAR pour les limites d'exposition de la population générale / non contrôlée dans IC RSS-102 et a été testé conformément aux méthodes et procédures de mesure spécifiées dans IEEE 1528.

**Warning**

IC Radiation Exposure Statement: This device has been tested and meets applicable limits for Radio Frequency (RF) exposure. This device was tested with a separation distance of 31 mm. Always keep the device away from your body to ensure exposure levels remain at or below the tested levels.

**Warning**

Cet appareil a été testé et respecte les limites applicables en matière d'exposition aux radiofréquences (RF). Cet appareil a été testé avec une distance de séparation de 25 mm. Gardez toujours l'appareil éloigné de votre corps pour vous assurer que les niveaux d'exposition restent égaux ou inférieurs aux niveaux testés.

Standard power access points subject to following conditions:

1. Operation on oil platforms, automobiles, trains, maritime vessels, and aircraft shall be prohibited.
2. The antenna height shall be determined by the install[er] or operator of the standard-power access point or fixed client device, or by automatic means. This information shall be stored internally in the device. Provision of accurate device information is mandatory.

Points d'accès à l'alimentation standard soumis aux conditions suivantes:

1. L'exploitation sur les plates-formes pétrolières, les automobiles, les trains, les navires maritimes et les avions est interdite.
2. La hauteur de l'antenne doit être déterminée par l'installateur ou l'opérateur du point d'accès à puissance standard ou de l'appareil client fixe, ou par des moyens automatiques. Ces informations doivent être stockées en interne dans l'appareil. La fourniture d'informations précises sur l'appareil est obligatoire.

Mexico Compliance Statement

La operación de este equipo está sujeta a las siguientes dos condiciones

1. es posible que este equipo o dispositivo no cause interferencia perjudicial y
2. este equipo o dispositivo debe aceptar cualquier interferencia, incluyendo la que pueda causar su operación no deseada.

The operation of this equipment is subject to the following two conditions:

1. it is possible that this equipment or device does not cause disruptive interference and

2. this equipment or device must accept any interference, including interference that may cause undesired operation.

Brazil Agência Nacional De Telecomunicações (Anatel) Statement

Este produto está homologado pela Anatel, de acordo com os procedimentos regulamentados e atende aos requisitos técnicos aplicados.

Este equipamento não tem direito à proteção contra interferência prejudicial e não pode causar interferência em sistemas devidamente autorizados. Para maiores informações, consulte o site da Anatel – www.anatel.gov.br

Taiwan Regulatory Statement

臺灣

低功率電波輻射性電機管理辦法

第十二條

經型式認證合格之低功率射頻電機，非經許可，公司、商號或使用者均不得擅自變更頻率、加大功率或變更原設計之特性及功能。

第十四條

低功率射頻電機之使用不得影響飛航安全及干擾合法通信；經發現有干擾現象時，應立即停用，並改善至無干擾時方得繼續使用。

前項合法通信，指依電信規定作業之無線電通信。

低功率射頻電機須忍受合法通信或工業、科學及醫療用電波輻射性電機設備之干擾。

無線接入點 (專業安裝)

1. 「本公司於說明書中提供所有必要資訊以指導使用者/安裝者正確的安裝及操作」警語。

並於該中文使用說明書及器材上標示

2. 「本器材須經專業工程人員安裝及設定，始得設置使用，且不得直接販售給一般消費者」警語。

「不致造成違反低功率電波輻射性電機管理法之所有控制、調整及開關之使用方法」。

「對任何可能造成違反管理法規定之調整予以警告，或建議由具有發射機維修專長之技術人員執行或由其直接監督及負責」。

「對任何可能造成違反管理法之零件(晶體、半導體等)置換之警告」。

「電磁波曝露量MPE標準值 $1\text{mW}/\text{cm}^2$ ，本產品使用時建議應距離人體：35 cm」。



Thailand Regulatory Statement

เครื่องโทรคมนาคมและอุปกรณ์นี้ มีความสอดคล้องตามมาตรฐานหรือข้อกำหนดทางเทคนิคของ กสทช.

MPE

เครื่องวิทยุคมนาคมนี้มีระดับการแผ่คลื่นแม่เหล็กไฟฟ้าสอดคล้องตามมาตรฐานความปลอดภัยต่อสุขภาพของมนุษย์

หากการใช้เครื่องวิทยุคมนาคมที่คณะกรรมการกิจการโทรคมนาคมแห่งชาติประกาศกำหนด



United Kingdom (UK) and European Union (EU) Radiation Warning Statement

The device is restricted to indoor use only when operating in the 5150 MHz to 5350 MHz frequency range.

The device is restricted to indoor use only when operating in the 5150 MHz to 5350 MHz frequency range.

	AT	BE	BG	HR	CY	CZ	DK
	EE	FI	FR	DE	EL	HU	IE
	IT	LV	LT	LU	MT	NL	PL
	PT	RO	SK	SI	ES	SE	UK (NI)

The frequency and the maximum transmitted power in EU and UK are listed below:

AP5050D EU	AP5050D UK
2400-2483.5MHz: 19.99 dBm	2400-2483.5MHz: 19.99 dBm
2400-2483.5MHz(LE): 6.59 dBm	2400-2483.5MHz(LE): 6.59 dBm
2400-2483.5MHz (802.15.4): 6.89 dBm	2400-2483.5MHz (802.15.4): 6.89 dBm
5150-5250MHz: 22.94 dBm	5150-5250MHz: 22.94 dBm
5250-5350MHz: 22.97 dBm	5250-5350MHz: 22.97 dBm
5470-5725MHz: 28.28 dBm	5470-5725MHz: 28.28 dBm
5725-5850MHz(EN 300 440): 13.96 dBm	5725-5850MHz: 22.98 dBm

**Warning**

This equipment complies with EU/UK radiation exposure limits set forth for an uncontrolled environment. This equipment should be installed and operated with a minimum distance of 21 cm between the radiator and your body.

Extreme Networks UK Address

Extreme Networks, UK Ltd.

250 Longwater Avenue Green Park

1st Floor

Reading, UK

Extreme Networks EU Importer Address

Extreme Networks, Ireland Ops Ltd.

Rineanna House Shannon Industrial Estate

Shannon, V14CA36 Ireland

European Waste Electrical and Electronic Equipment (WEEE) Notice

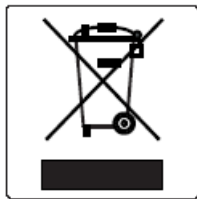

In accordance with Directive 2012/19/EU of the European Parliament on waste electrical and electronic equipment (WEEE):

1. The symbol above indicates that separate collection of electrical and electronic equipment is required.
2. When this product has reached the end of its serviceable life, it cannot be disposed of as unsorted municipal waste. It must be collected and treated separately.
3. It has been determined by the European Parliament that there are potential negative effects on the environment and human health as a result of the presence of hazardous substances in electrical and electronic equipment.
4. It is the user's responsibility to utilize the available collection system to ensure WEEE is properly treated.

For information about the available collection system, please contact Extreme Environmental Compliance at Green@extremenetworks.com.

Declaration of Conformity in Languages of the European Community

English	Hereby, Extreme Networks declares that the radio equipment type (AP5050D) is in compliance with Radio Equipment Regulations 2017 and Directive 2014/53/EU. For full text of the EU Declaration of Conformity, contact Extreme Regulatory Compliance at compliancerequest@extremenetworks.com
Finnish	Valmistaja Extreme Networks vakuuttaa täten että Radio LAN device (AP5050D) tyyppinen laite on Radiolaitteiden määräykset 2017 ja direktiivin 2014/53/EU oleellisten vaatimusten ja sitä koskevien direktiivin muiden ehtojen mukainen. EU-vaatimusten mukaisuusvaatimuksen täydellisestä tekstistä ota yhteyttä äärimmäisiin säädösten noudattamiseen osoitteessa compliancerequest@extremenetworks.com
Dutch	Hierbij verklaart Extreme Networks dat het toestel Radio LAN device (AP5050D) in overeenstemming is met de essentiële eisen en de andere relevante bepalingen van Regelgeving radioapparatuur 2017 en richtlijn 2014/53/EU. Neem voor de volledige tekst van de EU-conformiteitsverklaring u contact opnemen met extreme regelgeving op compliancerequest@extremenetworks.com
French	Par la présente Extreme Networks déclare que l'appareil Radio LAN device AP5050D est conforme aux exigences essentielles et aux autres dispositions pertinentes de la Règlement sur les équipements radio 2017 et directive 2014/53/EU. Pour obtenir le texte intégral du processus de Déclaration de la conformité de l'UE, veuillez contacter la conformité réglementaire extrême à l'adresse suivante: compliancerequest@extremenetworks.com
Swedish	Härmed intygar Extreme Networks att radioutrustningstypen (AP5050D) överensstämmer med de väsentliga egenskapskrav och övriga relevanta bestämmelser som framgår av Radioutrustningsföreskrifter 2017 och direktiv 2014/53/ EU. För fullständig text av EU-försäkran om överensstämmelse, kontakta Extreme regelefterlevnad på compliancerequest@extremenetworks.com
Danish	Undertegnede Extreme Networks erklærer herved, at følgende udstyr Radio LAN device (AP5050D) overholder de væsentlige krav og øvrige relevante krav i Radioudstyrsforskrifter 2017 og direktiv 2014/53/EU. For den fulde ordlyd af EU-overensstemmelseserklæringen bedes du kontakte Extreme Regulatory Compliance på compliancerequest@extremenetworks.com
German	Hiermit erkläre Extreme Networks die Übereinstimmung des "WLAN Wireless Controller bzw. Access Points" (AP5050D) mit den grundlegenden Anforderungen und den anderen relevanten Festlegungen der Funkgeräteverordnung 2017 und Richtlinie 2014/53/EU. Für den vollständigen Wortlaut der EU-Konformitätserklärung wenden Sie sich bitte an extreme Regulatory Compliance unter compliancerequest@extremenetworks.com
Greek	ΜΕ ΤΗΝ ΠΑΡΟΥΣΑ Extreme Networks ΔΗΛΩΝΕΙ ΟΤΙ Radio LAN device (AP5050D) ΣΥΜΜΟΡΦΩΝΕΤΑΙ ΠΡΟΣ ΤΙΣ ΟΥΣΙΩΔΕΙΣ ΑΠΑΙΤΗΣΕΙΣ ΚΑΙ ΤΙΣ ΛΟΙΠΕΣ ΣΧΕΤΙΚΕΣ ΔΙΑΤΑΞΕΙΣ ΤΗΣ ΟΔΗΓΙΑΣ 2014/53/EU. Για το πλήρες κείμενο της δήλωσης συμμόρφωσης ΕΕ, παρακαλούμε επικοινωνήστε με την ακραία κανονιστική συμμόρφωση στο compliancerequest@extremenetworks.com

Icelandic	Extreme Networks lýsir hér með yfir að þessi bunadur, Radio LAN device (AP5050D), uppfyllir allar grunnkröfur, sem gerðar eru í R&TTE tilskipun 2017 καα ESB nr 2014/53/EU. Fyrir fullan texta í ESB yfirlýsingu um samræmi, vinsamlegast hafðu samband við Extreme Reglufylgni á compliancerequest@extremenetworks.com
Italian	Con la presente Extreme Networks dichiara che questo Radio LAN device (AP5050D) è conforme ai requisiti essenziali ed alle altre disposizioni pertinenti stabilite dalla direttiva 2014/53/EU. Per il testo integrale della Dichiarazione di conformità dell'UE, contattare Extreme Regulatory Compliance presso compliancerequest@extremenetworks.com
Spanish	Por medio de la presente Extreme Networks declara que el Radio LAN device (AP5050D) cumple con los requisitos esenciales y cualesquiera otras disposiciones aplicables o exigibles de la Regolamenti sulle apparecchiature radio 2017 e Directiva 2014/53/EU. Para obtener el texto completo de la Declaración de conformidad de la UE, póngase en contacto con Extreme Regulatory Compliance en compliancerequest@extremenetworks.com
Portuguese	Extreme Networks declara que este Radio LAN device (AP5050D) está conforme com os requisitos essenciais e outras disposições da Regulamentos de Equipamentos de Rádio 2017 e Directiva 2014/53/EU. Para o texto integral da declaração de conformidade da UE, contacte a conformidade regulamentar extrema em compliancerequest@extremenetworks.com
Malti	Hawnhekk, Extreme Networks, jiddikjara li dan Radio LAN device (AP5050D) jikkonforma mal-htigijiet essenzjali u ma provvedimenti oħrajn rilevanti li hemm fid-Regolamenti tal-2017 dwar it-Tagħmir tar-Radju u Dirrettiva 2014/53/EU. Għat-test sħiħ tad-dikjarazzjoni ta ' konformità tal-UE, jekk jogħġbok ikkuntattja lill-konformità regolatorja compliancerequest@extremenetworks.com



Index

A

- ACC-MBO-KT-AX adapter wall install with MBO-ART03 bracket 32
- access point features 11
- access point LED status 14, 15
- access point overview 9
- announcements 7
- AP5050D access point overview 9
- AP5050D features 11
- AP5050D supported accessories 13

B

- Brazil compliance statement 60

C

- connect the ETH1 or ETH0 cable
 - ETH0 cable 49
 - ETH1 cable 49
- console port 13
- conventions
 - notice icons 5
 - text 5

D

- do's and don'ts 19, 20
- documentation
 - feedback 8
 - location 6

E

- ETH0 conduit bracket connection 52
- ETH1 conduit bracket connection 52
- EU importer address 63
- EU radiation warning 62

F

- feedback 8

G

- ground connection
 - ground screw 48
 - ground screw hole
 - lightning protection 48

I

- industry Canada notice 58
- installation process
 - box contents 18
 - how-to-install the access point 18
 - purchase order information 18
 - safety guidelines 18

K

- KT-147407-02 bracket
 - mount on a pole with MBO-Art03 bracket 36
- KT-150173-01 extension arm installation 27

L

- LED activity 14, 15
- LED status activity 14, 15

M

- MBO-Art03 bracket
 - mount on a pole with KT-147407-02 bracket 36
- MBO-ART03 Unistrut install 42
- Mexico compliance statement 59
- Mount on a pole
 - with the MBO-ART03 and KT-147407-02 36
- Mount on a wall
 - with the the MBO-ART03 29
- mounting bracket
 - AP5050D mounting bracket 21
- mounting options
 - AP5050D mounting options 21

N

- New in this Guide 9, 10
- notices 5

O

- order information KT-150173-01 extension arm order information
 - AP5050D order information 15–17
 - KT-147407-02 order information 15–17

P

- pole installation
 - ART02 on POLE01 bracket 40
 - KT-147407-02 bracket parts 33
 - MBO-Art03 and and KT-147407-02 brackets 36
- pole installation using KT-150173-01 extension arm 37
- power profile 12
- pressure wash
 - nozzle information 47
 - safety guidelines 47
- product announcements 7
- professional install 56

R

- radiation exposure statement 57

S

- safety guidelines 55
- secure the access point
 - safety cable installation 46
- service panels installation 44
- support, *see* technical support

T

- Taiwan Regulatory Statement 60
- technical support
 - contacting 7
- Thailand Regulatory Statement 61

U

- UK address 63
- UK radiation warning 62

W

- wall install
 - ART02 articulating mounting bracket install 30
 - ART03 articulating mounting bracket install 29
- wall installation
 - wall install using KT-147407-02 and KT-150173-01 extension arm 26
- Wall installation
 - wall installation using KT-147407-02 bracket 23
- warnings 5
- WS-MBO-POLE01 bracket 36