

ExtremeCloudTM Appliance E3120

Installation Guide



Copyright © 2019 Extreme Networks, Inc. All rights reserved.

Legal Notice

Extreme Networks, Inc. reserves the right to make changes in specifications and other information contained in this document and its website without prior notice. The reader should in all cases consult representatives of Extreme Networks to determine whether any such changes have been made.

The hardware, firmware, software or any specifications described or referred to in this document are subject to change without notice.

Trademarks

Extreme Networks and the Extreme Networks logo are trademarks or registered trademarks of Extreme Networks, Inc. in the United States and/or other countries.

All other names (including any product names) mentioned in this document are the property of their respective owners and may be trademarks or registered trademarks of their respective companies/owners.

For additional information on Extreme Networks trademarks, please see:

www.extremenetworks.com/company/legal/trademarks

Open Source Declarations

Some software files have been licensed under certain open source or third-party licenses. End-user license agreements and open source declarations can be found at:

www.extremenetworks.com/support/policies/software-licensing

Table of Contents

Preface	4
Conventions.....	4
Providing Feedback to Us.....	5
Getting Help.....	5
Documentation and Training.....	6
Chapter 1: Overview	7
E3120 Control Panels.....	7
Hard Drive LED Indicator Patterns.....	9
Chapter 2: Hardware Installation	11
Verifying the Box Contents.....	11
Attaching the Front Bezel.....	12
Power Supply Options.....	12
Connecting to a Power Source.....	16
Chapter 3: Initial Network Connection and Configuration	18
Configuring the Management Interface via Console Port.....	18
Configuring the Management Interface via the Management Port.....	19
Connecting the Data Ports.....	19
Chapter 4: Specifications	22
Chapter 5: Regulatory Information	23
Regulatory Compliance Information.....	23
Federal Communications Commission (FCC) Notice.....	23
Industry Canada, Class A.....	23
CE Notice.....	24
Japan (VCCI) - Voluntary Control Council for Interference Class A ITE.....	24
BSMI EMC Statement - Taiwan.....	24
Supplement to Product Instructions.....	25
Hazardous Substances.....	25
European Waste Electrical and Electronic Equipment (WEEE) Notice.....	26
Index	27

Preface

This section discusses the conventions used in this guide, ways to provide feedback, additional help, and other Extreme Networks® publications.

Conventions

This section discusses the conventions used in this guide.

Text Conventions

The following tables list text conventions that are used throughout this guide.

Table 1: Notice Icons





Icon	Notice Type	Alerts you to...
	General Notice	Helpful tips and notices for using the product.
	Note	Important features or instructions.
	Caution	Risk of personal injury, system damage, or loss of data.
	Warning	Risk of severe personal injury.
<i>New!</i>	New Content	Displayed next to new content. This is searchable text within the PDF.

Table 2: Text Conventions

Convention	Description
<code>Screen displays</code>	This typeface indicates command syntax, or represents information as it appears on the screen.
The words enter and type	When you see the word “enter” in this guide, you must type something, and then press the Return or Enter key. Do not press the Return or Enter key when an instruction simply says “type.”
[Key] names	Key names are written with brackets, such as [Return] or [Esc] . If you must press two or more keys simultaneously, the key names are linked with a plus sign (+). Example: Press [Ctrl]+[Alt]+[Del]
<i>Words in italicized type</i>	Italics emphasize a point or denote new terms at the place where they are defined in the text. Italics are also used when referring to publication titles.

Providing Feedback to Us

Quality is our first concern at Extreme Networks, and we have made every effort to ensure the accuracy and completeness of this document. We are always striving to improve our documentation and help you work better, so we want to hear from you! We welcome all feedback but especially want to know about:

- Content errors or confusing or conflicting information.
- Ideas for improvements to our documentation so you can find the information you need faster.
- Broken links or usability issues.

If you would like to provide feedback to the Extreme Networks Information Development team, you can do so in two ways:

- Use our short online feedback form at <https://www.extremenetworks.com/documentation-feedback/>.
- Email us at documentation@extremenetworks.com.

Please provide the publication title, part number, and as much detail as possible, including the topic heading and page number if applicable, as well as your suggestions for improvement.

Getting Help

If you require assistance, contact Extreme Networks using one of the following methods:

- | | |
|-----------------------|--|
| Extreme Portal | Search the GTAC (Global Technical Assistance Center) knowledge base, manage support cases and service contracts, download software, and obtain product licensing, training, and certifications. |
| The Hub | A forum for Extreme Networks customers to connect with one another, answer questions, and share ideas and feedback. This community is monitored by Extreme Networks employees, but is not intended to replace specific guidance from GTAC. |
| Call GTAC | For immediate support: 1-800-998-2408 (toll-free in U.S. and Canada) or +1 408-579-2826. For the support phone number in your country, visit: www.extremenetworks.com/support/contact |

Before contacting Extreme Networks for technical support, have the following information ready:

- Your Extreme Networks service contract number and/or serial numbers for all involved Extreme Networks products
- A description of the failure
- A description of any action(s) already taken to resolve the problem
- A description of your network environment (such as layout, cable type, other relevant environmental information)
- Network load at the time of trouble (if known)
- The device history (for example, if you have returned the device before, or if this is a recurring problem)
- Any related RMA (Return Material Authorization) numbers

Subscribing to Service Notifications

You can subscribe to email notifications for product and software release announcements, Vulnerability Notices, and Service Notifications.

- 1 Go to www.extremenetworks.com/support/service-notification-form.
- 2 Complete the form with your information (all fields are required).
- 3 Select the products for which you would like to receive notifications.

**Note**

You can modify your product selections or unsubscribe at any time.

- 4 Click **Submit**.

Documentation and Training

To find Extreme Networks product guides, visit our documentation pages at:

Current Product Documentation	www.extremenetworks.com/documentation/
Archived Documentation (for earlier versions and legacy products)	www.extremenetworks.com/support/documentation-archives/
Release Notes	www.extremenetworks.com/support/release-notes
Hardware/Software Compatibility Matrices	https://www.extremenetworks.com/support/compatibility-matrices/
White papers, data sheets, case studies, and other product resources	https://www.extremenetworks.com/resources/

Training

Extreme Networks offers product training courses, both online and in person, as well as specialized certifications. For more information, visit www.extremenetworks.com/education/.

1 Overview

E3120 Control Panels Hard Drive LED Indicator Patterns

E3120 appliance is a high-end ExtremeCloud Appliance that supports five thousand standalone devices, fifty thousand users, and provides availability for up to ten thousand devices and hundred thousand users, with any client distribution between appliances.



Attention

Only qualified personnel should perform installation procedures.



Caution

To minimize Electrostatic Discharge (ESD) to the devices, you must wear an antistatic wrist strap while performing the following procedures.

E3120 Control Panels

E3120 front panel layout



Label	Description
1	Hard disk drive bays
2	Front video connector
3	USB 2.0 or 3.0 ports



Note

For USB key storage only: Although the appliance has five USB connectors (two on the front panel and three on the back panel), only one USB connector can be in use at any given time.

E3120 back panel layout

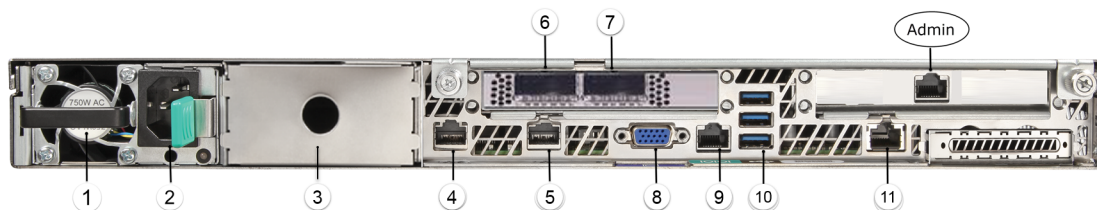

Label	Description
1	Power supply module #1
2	Retention strap receiver hole
3	Power supply module #2 bay for redundant power supply
4	Port 1 (Data Port 1) 1/10GbE, RJ45
5	Port 2 (Data Port 2) 1/10GbE, RJ45
6	Port 3 (Data Port 3) 1/10/25/40GbE, QSFP28
7	Port 4 (Data Port 4) 1/10/25/40GbE, QSFP28
8	Video connector
9	RJ45 Serial-A Port
10	USB 3.0 ports
11	RMM4 NIC port (not used, plugged)
Admin	Management port; 1GbE, RJ45

E3120 front control panel

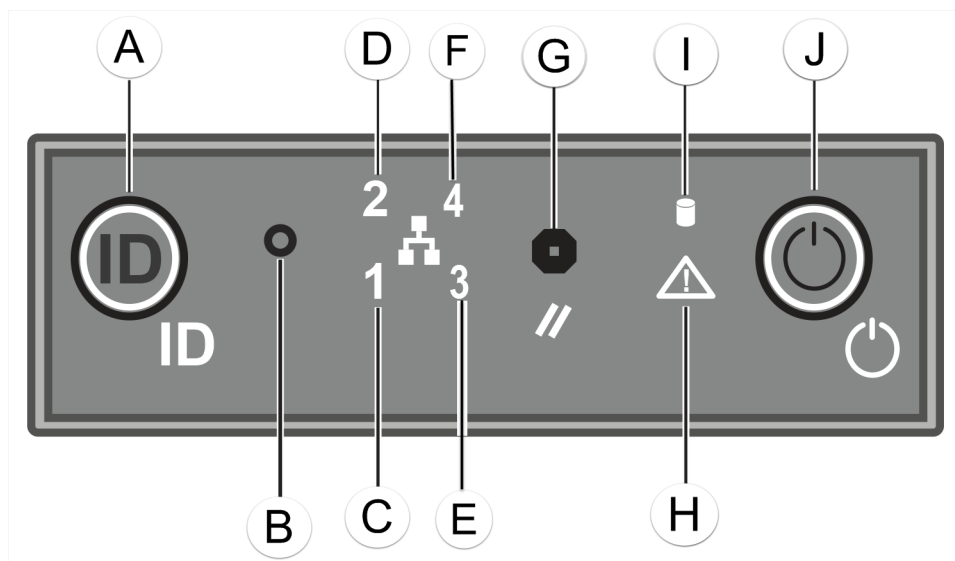

Label	Description
A	System ID button with integrated LED
B	NMI button
C	Data Port 1 activity LED
D	Data Port 2 activity LED
E	Not used
F	Not used
G	System cold reset button
H	Drive activity LED
I	System status LED
J	Power button with integrated LED

Hard Drive LED Indicator Patterns

The hard drive has one LED indicator visible from the front of the system — a green LED for disk activity (see [Front Control Panel](#)).

The system status LED is a bi-color indicator that shows the current health of the server, which is described in the following table:

Table 3: System LED patterns

LED Pattern	System Status	Description
Solid green	Ok	Indicates that the system is normally running without any errors.
1 Hz blinking green	Issues with the system	Indicates that: <ul style="list-style-type: none"> • There might be redundancy loss in the power supply or fan. • The non-critical threshold has crossed due to temperature, input power to power supply, voltage, output current for main power rail from power supply, and process thermal control sensors. • Power supply failure may have occurred while redundant power supply was present. • There is a fault in the hard drive. • The appliance is unable to use all of the installed memory. • The battery has failed.
1 Hz blinking amber	Fatal or unrecoverable system hardware failure	Amber color means there has been a fatal error in the system. System failure is caused when: <ul style="list-style-type: none"> • Critical threshold is crossed. • Minimum number of fans to cool the system is not present or the fans have failed. • The required number of power supply is not present in the system.

2 Hardware Installation

Verifying the Box Contents
Attaching the Front Bezel
Power Supply Options
Connecting to a Power Source

To prepare for Hardware Installation of E3120:

- 1 Match the model number on the purchase order with the model number in the packing list and on the E3120 appliance.

Table 4: E3120 product information

Part number	Description
30139	E3120 Appliance. Expandable management for up to 5000 access points.

- 2 Verify that the contents of the box include the E3120 appliance and that the included hardware matches the [package contents](#).
- 3 Review the Safety Guidelines.

Verifying the Box Contents

Before you install the E3120 appliance, make sure that you have all the necessary parts.

- 1 Verify that the box contains the following items:

Table 5: E3120 box contents

Quantity	Item
1	E3120 Quick Reference
1	E3120 appliance
2	Shipping lock screws
1	AC power cord bracket and retention strap kit
1	Rail mounting kit

Table 5: E3120 box contents (continued)

Quantity	Item
1	Front panel bezel
1	Rail kit installation instruction sheet

**Note**

The power cord needs to be purchased separately for the respective deployment country. It can be ordered at <https://www.extremenetworks.com/powercords>.

- 2 Perform a visual inspection of the appliance for any physical damage. Contact [Extreme Networks Support Portal](#) if there is any damage.

Attaching the Front Bezel

The appliance comes with an optional front panel bezel, which can be attached to the front of the chassis by snapping it on the rack handles. A key lock allows you to lock the bezel in place to restrict access to the controls on the front panel. You can monitor the system status indicators with the bezel in place.

- 1 Lock the right end of the front bezel to the rack handle (see label "A").
- 2 Push the front bezel until the left end clicks into place (see label "B").

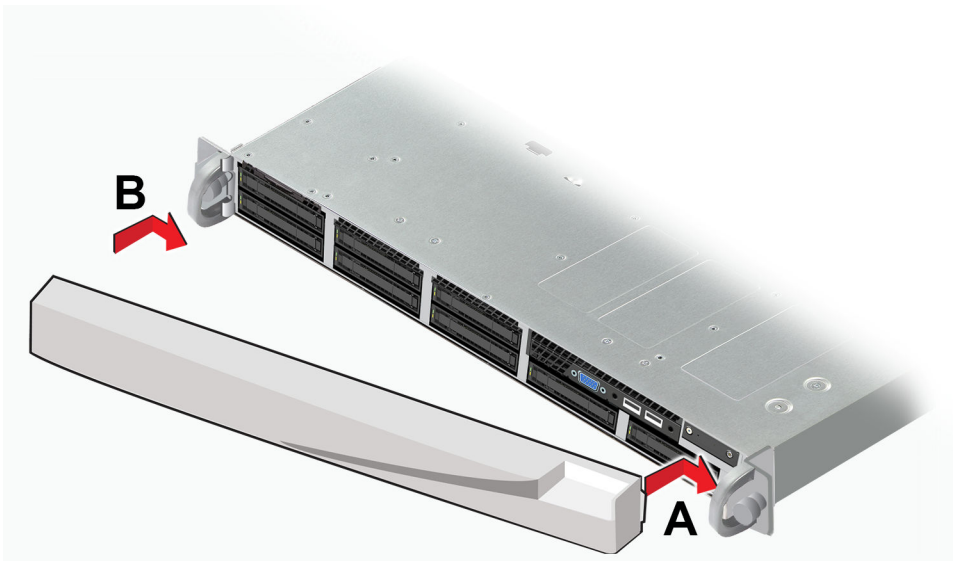
**Figure 1: Attaching the front bezel**

- 3 Lock the bezel, if needed.

Power Supply Options

You have the option to install, remove, and replace a power supply on the E3120 appliance. The E3120 appliance ships with one power supply and it comes installed. Additional redundant power supplies can be purchased separately (ordering part number, 30527 WS-PSI-1100W-01).

Each power supply has a single bi-color LED to indicate power supply status. The LED indicator patterns are described in the following table.

Table 6: Power supply status LED indicator patterns

Power supply condition	LED pattern
Output On and OK	Green
No AC power to all power supplies	Off
AC present/ Only 12VSB On (PS Off) or PS in cold redundant state	1 Hz blinking green
AC power cord unplugged or AC power lost, with a second PS in parallel still with AC input power	Amber
Power supply warning events where PS continues to operate - high temperature, high power, high current, and slow fan	1 Hz blinking amber
Power supply critical event causing a shutdown, failure, OCP, OVP, and fan fail	Amber
Power supply firmware update	2 Hz blinking green

Installing a Redundant Power Supply

To install a power supply module:

- 1 If the power supply insert is installed, remove the insert from the chassis power supply module #2 bay.
- 2 Insert the power supply module into the power supply bay.

- 3 Push the power supply module into the bay until it locks into place.

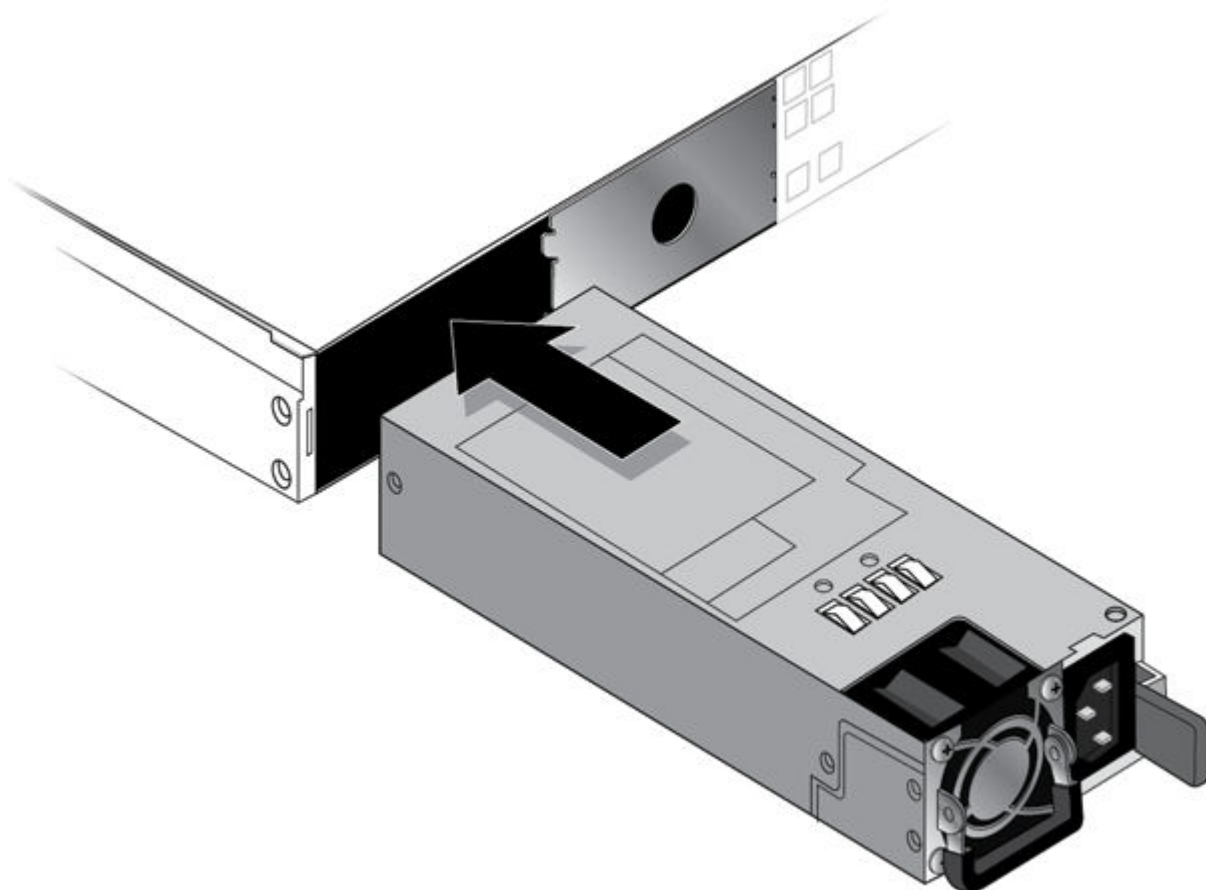

Figure 2: Installing a power supply module

- 4 [Connect the unit to a power source.](#)

Removing a Power Supply

To remove a power supply module:

- 1 Detach the power supply cord from the power supply module that needs to be removed.

- 2 Pull the power supply module using the handle, while pushing the latching tab outward to disengage the power supply module from the unit.

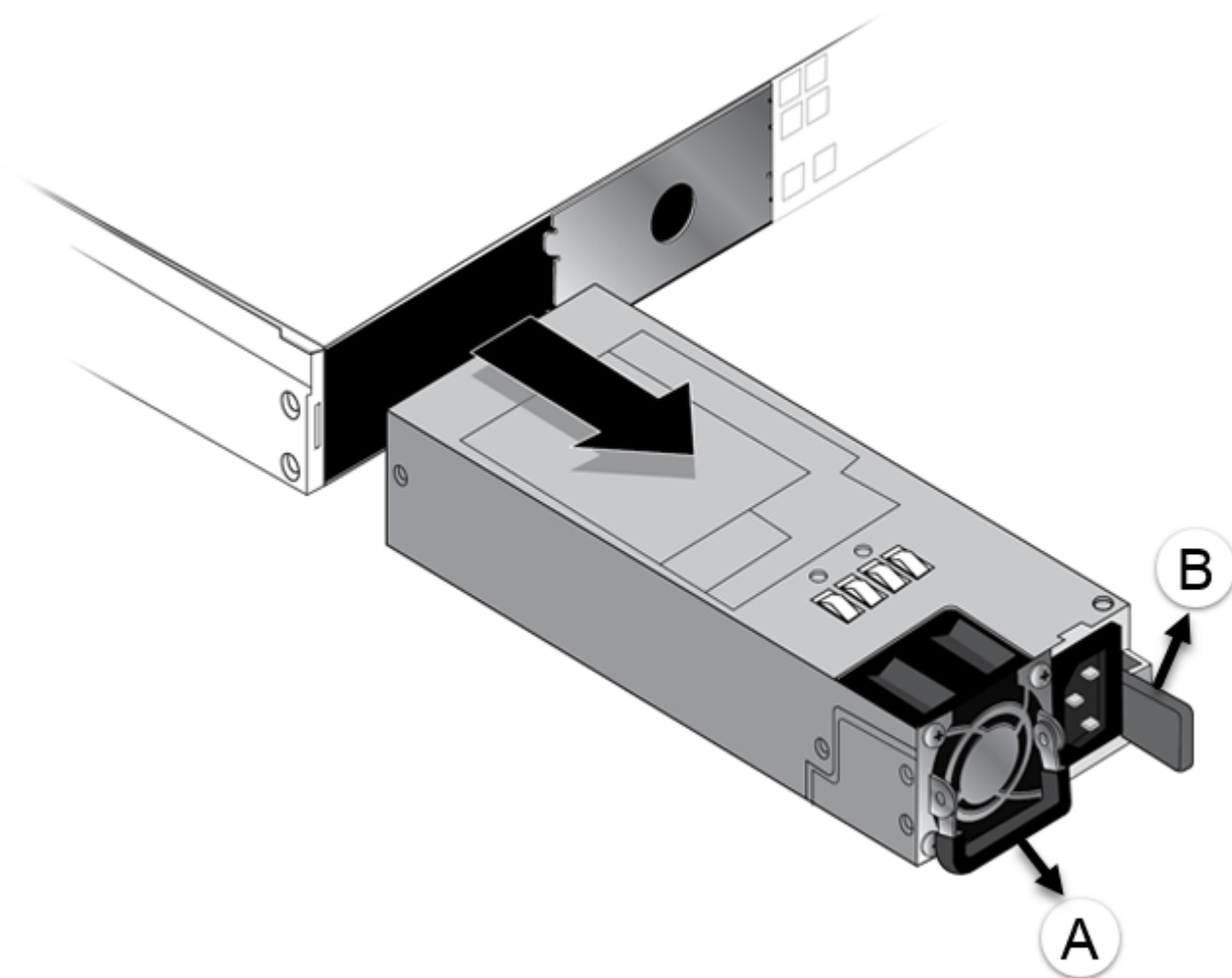

Figure 3: Removing a power supply module

Label	Description
A	Handle
B	Latching tab

Replacing a Power Supply

To replace a power supply:

- 1 Detach the power supply cord from the power supply module that needs to be removed:
 - 1 Release the slider strap on the power supply cord by pushing down the slider tab.
 - 2 Pull the slider strap over the power supply cord.
 - 3 Remove the power cord from the power supply module.

- 2 Pull out the power supply module using the handle, while pushing the green latch on the power supply module outward to remove the power supply module.

**Note**

The appliance requires one power supply to operate the system normally. Remove and replace only one power supply module at a time in a system that is powered on.

- 3 Refer to [Installing a Redundant Power Supply](#) on page 13 to install the replacement power supply module into the power supply bay.

Connecting to a Power Source

Locate the power cord retention strap from the AC power cord bracket and cable clamp kit.

To connect the E3120 unit to a power source:

- 1 Attach the power cord to the power supply module:
 - 1 Insert the locking tab end of the retention strap into the receiver hole of the power supply unit, located to the right of Power Supply #1.
 - 2 Adjust the slider of the retention strap by pushing up the locking tab on the bottom of the slider.
 - 3 If you are using another power cord to create an optional redundant power supply, connect the two AC power cords to power supplies #1 and #2. These two power supplies combine and create an optional redundant power supply.
 - 4 Lock the retention strap to the power cord by pulling the slider strap over the power cord.

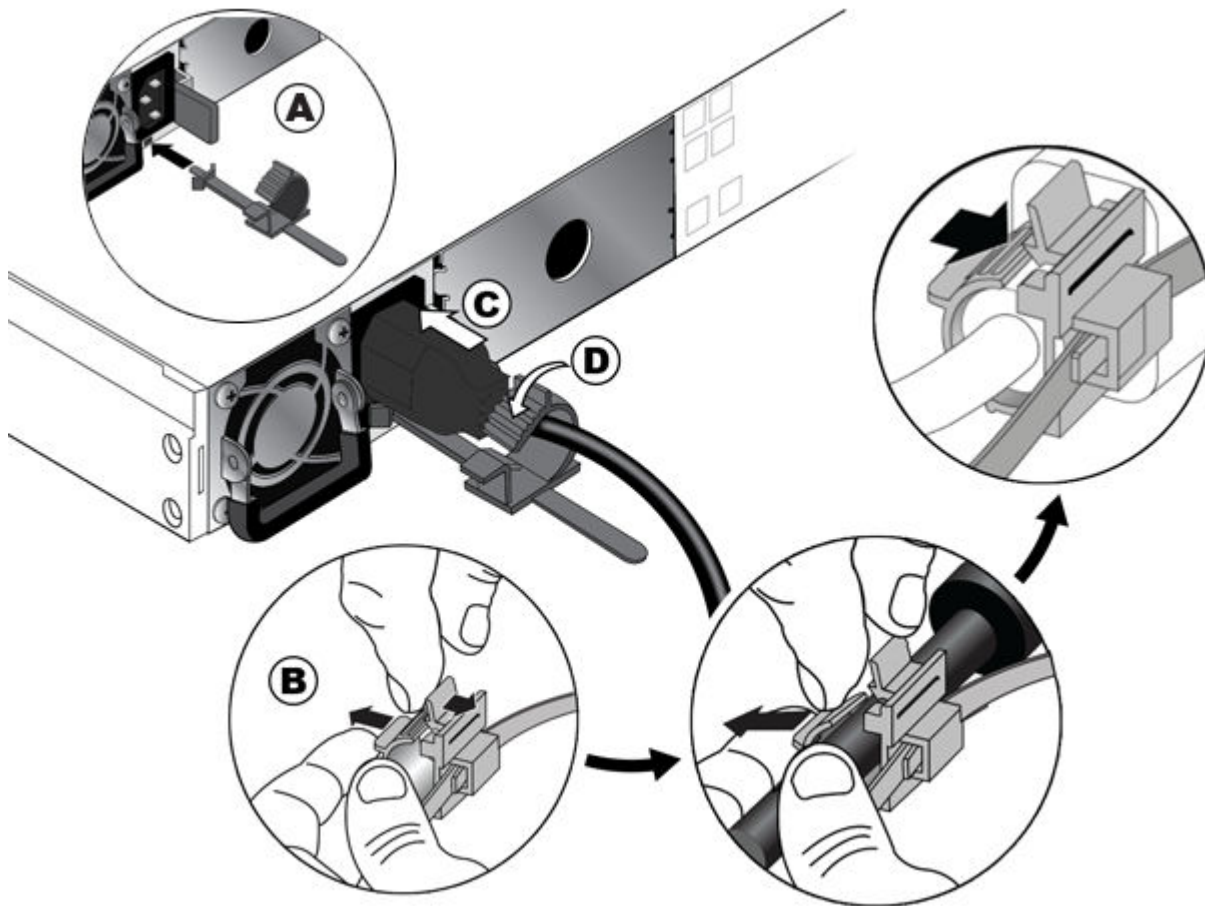

Figure 4: Attaching the power cord to the appliance

- 2 Plug the other end of the power cords into grounded electrical outlets or to separate power sources, such as an uninterruptible power supply (UPS) or a power distribution unit (PDU).
- 3 Using the power button on the [front control panel](#), turn on the appliance.



Note

The power button must be pressed to turn it on. The appliance is on only when the power button LED is on.

3 Initial Network Connection and Configuration

Configuring the Management Interface via Console Port
Configuring the Management Interface via the Management Port
Connecting the Data Ports

Configuring the Management Interface via Console Port

The E3120 must be upgraded to the latest ExtremeCloud Appliance firmware before installing the appliance on the network.

- 1 Connect the laptop to the E3120 console port. If the laptop does not support RS232 interface, then obtain a 'USB to RS232' converter cable, which then connects to the RJ45- DB9F cable.
- 2 Using PuTTY, TeraTerm, or another terminal emulator, connect to the serial port connection.

Be sure that your serial connection is set properly:

- 115200 baud
 - 8 data bits
 - 1 stop bit
 - Parity none
 - Flow control none
- 3 Using the console session, perform the following:
 - At the password prompt, enter user as: `admin`
 - For the initial password, enter: `abc123`
 - Press **ENTER**.
 - 4 Read the configuration script paragraph carefully. The configuration script will walk you through configuring the following:
 - Admin Password
 - Host Attributes Settings
 - Time Settings
 - SNMP Settings
 - Data Plane Settings
 - 5 At the end of each session, enter `Yes` to move to the next session. If you enter `No`, the session configuration options are repeated.
 - 6 Press **ENTER**.
 - 7 The **Appliance Post Installation Configuration Menu** pops up after the last session is applied. Enter `A` to apply settings and exit or other number for repeating the setup.

- 8 Connect to a port on which management access was enabled during the CLI Wizard Setup.
- 9 Open a web browser, and in the browser address bar, type: `https://Your_Mgmt_Ipaddress:5825`.
The ExtremeCloud Appliance's logon screen is displayed.
- 10 On the logon screen, enter the credentials that were created when setting up the installation wizard.

**Note**

An installation wizard is available to help configure the E3120 for new deployments. Refer to the ExtremeCloud Appliance User Guide on the [Extreme Networks Documentation Site](#) for more information.

Configuring the Management Interface via the Management Port

You can retain the default IP address of the appliance's management interface if you do not intend to connect the appliance to your enterprise network. If you do intend to connect the appliance to your network, follow these steps:

**Note**

The E3120 must be upgraded to the latest ExtremeCloud Appliance firmware before installing the appliance on the network.

- 1 Connect a laptop to the management port of the appliance.
- 2 Configure the Ethernet port of the laptop with a statically assigned unused IP address in the `192.168.10.0/24` subnet.
- 3 Open a web browser and, in the browser address bar, type `https://192.168.10.1:5825` (`192.168.10.1` is the default IP address on the appliance management port).
The ExtremeCloud Appliance logon screen is displayed.
- 4 Log on, as follows:
 - User name: `admin`
 - Password: `abc123`
 - Click **Login**.
- 5 To configure the E3120 appliance for new deployments, complete the installation.
- 6 Disconnect your laptop from the management port of the appliance.
- 7 Connect the appliance's management port to the enterprise Ethernet LAN.
- 8 Log on to Extreme Networks.

**Note**

The system is now visible to the enterprise network. Refer to the ExtremeCloud Appliance User Guide on the [Extreme Networks Documentation Site](#) for more information.

Connecting the Data Ports

Data Ports 1 and 2 are 1/10 GbE RJ45 ports. To connect to the data ports, start by connecting the twisted pair cabling:

- 1 Ensure that the device to be connected at the other end of the segment is powered on.
- 2 Connect the twisted pair segment to the appliance by inserting the RJ45 connector on the twisted pair segment into the desired RJ45 port.
- 3 Verify that a link exists by checking that the Activity Link LED is on (solid green or blinking green). If the Activity Link LED is off, perform the following steps until it is on:
 - 1 Verify that the cabling being used is Category 5 or better, with an impedance between 85 and 111 ohms and a maximum length of 100 meters (328 feet).
 - 2 Verify that the device at the other end of the twisted pair segment is turned on and is properly connected to the segment.
 - 3 Verify that the RJ45 connectors on the twisted pair segment have the proper pinouts, and check the cable for continuity.
- 4 If a link is not established, contact [Extreme Networks Support](#).

Data ports 3 and 4 provide QSFP28 ports that can support 40Gbps transceivers, as well as 1, 10, and 25 Gbps transceivers through special adapters. Refer to the [datasheet](#) for a list of pluggable transceivers supported for the E3120.

Installing a Transceiver or an Adapter:

To install a transceiver or adapter:

- 1 With an antistatic wrist strap attached to your wrist, remove the transceiver from its packaging. If there is a protective dust cover on the transceiver connector, do not remove it at this time.
- 2 Hold the transceiver so that the connector will seat properly.
- 3 Carefully align the transceiver with the port slot.
- 4 Push the transceiver into the port slot until it clicks and locks into place.

Connecting Cables to Transceiver Ports

To connect cables to transceiver ports:

- 1 Remove the protective covers from the transceiver and from the connectors on each end of the cable.
- 2 Insert the cable connector into the transceiver connector until it clicks into place.
- 3 Plug the other end of the cable into the appropriate port on the other device. Some fiber-optic cables may be terminated at the other end with two separate connectors, one for each fiber-optic strand. In this case, ensure that the transmit fiber-optic strand from the appliance is connected to the receive port of the other device, and the receive fiber-optic strand on the appliance is connected to the transmit port of the other device.
- 4 If a transceiver port is unused, install a dust cover.



Warning

Fiber-optic transceivers use Class 1 lasers. Do not use optical instruments to view the laser output. The use of optical instruments to view laser output increases eye hazard. When viewing the output optical port, power must be removed from the network adapter.

Port LED Patterns

RJ45 Port LEDs (Management Port)

LED Type	LED Pattern	Status Indication
Network Speed (Left)	Off	10 Mbps
	Green	100 Mbps
	Amber	1000 Mbps (1 Gbps)
Link Activity (Right)	Off	No link
	Solid Green	Active link
	Blinking Green	Data traffic activity

Port LEDs (Data Ports 1 and 2)

LED Type	LED Pattern	Status Indication
Network Speed (Right)	Solid Amber	1000 Mbps (1 Gbps)
	Solid Green	10000 Mbps (10 Gbps)
Link Activity (Left)	Off	No link
	Solid Green	Active link
	Blinking Green	Data traffic activity

QSFP28 Port LEDs (Data Ports 3 and 4)

LED Color and State	Description/Status Indication
Off	Physical link has not been established
Solid Yellow	Active physical link
Blinking Amber	4Hz
	Problem with the physical link
Solid Green	Valid logical (data activity) link with no active traffic
Blinking Green	Valid logical link with active traffic (data activity)

4 Specifications

Physical Specifications

Dimensions	<ul style="list-style-type: none">• Length: 31.25"• Width: 17.25"• Height: 1.7"
------------	---

Environmental Specifications

Operating Temperature	+5°C to +40°C (+32°F to +104°F)
Relative Humidity	0% to 95% (non-condensing)

5 Regulatory Information

Regulatory Compliance Information
Federal Communications Commission (FCC) Notice
Industry Canada, Class A
CE Notice
Japan (VCCI) - Voluntary Control Council for Interference Class A ITE
BSMI EMC Statement - Taiwan
Supplement to Product Instructions
Hazardous Substances
European Waste Electrical and Electronic Equipment (WEEE) Notice

Regulatory Compliance Information

For complete regulatory compliance and safety information, refer to the document [Intel® Server Products Product Safety and Regulatory Compliance](#).

Federal Communications Commission (FCC) Notice

This product has been tested and found to comply with the limits for a class A digital device, pursuant to Part 15 of the FCC rules. These limits are designed to provide reasonable protection against harmful interference when the equipment is operated in a commercial environment. This product uses, generates, and can radiate radio frequency energy and if not installed and used in accordance with the manufacturer's instruction manual, may cause harmful interference to radio communications. Operation of this product in a residential area is likely to cause harmful interference, in which case you will be required to correct the interference at your own expense.

This device complies with Part 15 of the FCC rules. Operation is subject to the following two conditions: (1) this device may not cause harmful interference, and (2) this device must accept any interference received, including interference that may cause undesired operation. Any changes or modifications not expressly approved by the grantee of this device could void the user's authority to operate the equipment. The customer is responsible for ensuring compliance of the modified product.

Intel Corporation 5200 N.E. Elam Young Parkway Hillsboro, OR 97124-6497

Phone: 1-800-628-8686

Industry Canada, Class A

This Class A digital apparatus complies with Canadian ICES-003. This digital apparatus does not exceed the Class A limits for radio noise emissions from digital apparatus set out in the interference-causing equipment standard entitled "Digital Apparatus," ICES-003 of the Canadian Department of Communications.

Cet appareil numérique respecte les limites bruits radioélectriques applicables aux appareils numériques de Classe A prescrites dans la norme sur le matériel brouilleur: "Appareils Numériques", NMB-003 édictée par le Ministre Canadian des Communications.

CE Notice

This product has been determined to be in compliance with 2006/95/EC (Low Voltage Directive), 2004/108/EC (EMC Directive).

Japan (VCCI) - Voluntary Control Council for Interference Class A ITE

This is a class A product based on the standard of the Voluntary Control Council for Interference by Information Technology Equipment (VCCI). If this equipment is used in a domestic environment, radio disturbance may arise. When such trouble occurs, the user may be required to take corrective actions.

この装置は、情報処理装置等電波障害自主規制協議会（VCCI）の基準に基づくクラスA情報技術装置です。この装置を家庭環境で使用すると電波妨害を引き起こすことがあります。この場合には使用者が適切な対策を講ずるよう要求されることがあります。

BSMI EMC Statement - Taiwan

This is a class A product. In a domestic environment this product may cause radio interference in which case the user may be required to take adequate measures.

警告使用者：

這是甲類的資訊產品，在居住的環境中使用時，可能會造成射頻干擾，在這種情況下，使用者會被要求採取某些適當的對策。

Supplement to Product Instructions

产品说明书附件 Supplement to Product Instructions

部件名称 (Parts)	有毒有害物质或元素 (Hazardous Substance)					
	铅 (Pb)	汞 (Hg)	镉 (Cd)	六价铬 (Cr ⁶⁺)	多溴联苯 (PBB)	多溴二苯醚 (PBDE)
金属部件 (Metal Parts)	×	○	○	×	○	○
电路模块 (Circuit Modules)	×	○	○	×	○	○
电缆及电缆组件 (Cables & Cable Assemblies)	×	○	○	×	○	○
塑料和聚合物部件 (Plastic and Polymeric parts)	○	○	○	○	○	×
电路开关 (Circuit Breakers)	○	○	×	×	○	○

○： 表示该有毒有害物质在该部件所有均质材料中的含量均在 SJ/T 11363-2006 标准规定的限量要求以下。
Indicates that the concentration of the hazardous substance in all homogeneous materials in the parts is below the relevant threshold of the SJ/T 11363-2006 standard.

×： 表示该有毒有害物质至少在该部件的某一均质材料中的含量超出SJ/T 11363-2006 标准规定的限量要求。
Indicates that the concentration of the hazardous substance of at least one of all homogeneous materials in the parts is above the relevant threshold of the SJ/T 11363-2006 standard.

对销售之日的所售产品, 本表显示, 凯创供应链的电子产品信息产品可能包含这些物质。注意: 在所售产品中可能会也可能不会含有所有所列的部件。
This table shows where these substances may be found in the supply chain of Extreme electronic information products, as of the date of sale of the enclosed product. Note that some of the component types listed above may or may not be a part of the enclosed product.

除非另外特别的标注, 此标志为针对所涉及产品的环保使用期标志。某些零部件会有一个不同的环保使用期(例如, 电池单元模块)贴在其产品上。此环保使用期限只适用于产品是在产品手册中所规定的条件下工作。
The Environmentally Friendly Use Period (EFUP) for all enclosed products and their parts are per the symbol shown here, unless otherwise marked. Certain parts may have a different EFUP (for example, battery modules) and so are marked to reflect such. The Environmentally Friendly Use Period is valid only when the product is operated under the conditions defined in the product manual.



Hazardous Substances

This product complies with the requirements of Directive 2011/65/EU of the European Parliament and of the Council of 8 June 2011 on the restriction of the use of certain hazardous substances in electrical and electronic equipment.

European Waste Electrical and Electronic Equipment (WEEE) Notice

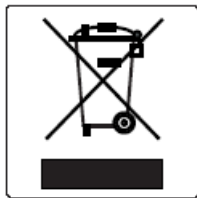

In accordance with Directive 2012/19/EU of the European Parliament on waste electrical and electronic equipment (WEEE):

- 1 The symbol above indicates that separate collection of electrical and electronic equipment is required.
- 2 When this product has reached the end of its serviceable life, it cannot be disposed of as unsorted municipal waste. It must be collected and treated separately.
- 3 It has been determined by the European Parliament that there are potential negative effects on the environment and human health as a result of the presence of hazardous substances in electrical and electronic equipment.
- 4 It is the users' responsibility to utilize the available collection system to ensure WEEE is properly treated.

For information about the available collection system, please contact Extreme Environmental Compliance at Green@extremenetworks.com.

Index

B

Box Contents 11

C

conventions
notice icons 4
text 4

D

Data Ports, Connecting the Data Ports 19
documentation
feedback 5
location 6

E

E3120 Configuration, Initial Network Connection, Initial Configuration, Configuration, Network Connection 18
E3120 Configuration, Management Interface Configuration, Configuration via Management Port 19
E3120 Control Panels, Control Panel, Front Control Panel, Back Control Panel, Layout, Front Panel Layout, Back Panel Layout 7, 8
E3120 Front Bezel, Attaching the Front Bezel, Installation Procedure 12
E3120 Interface, Management Interface, Console Port, E3120 Console Port, Management Interface Configuration, E3120 Configuration 18
E3120 Overview, Overview, Overview of E3120 Controller 7
E3120 Ports, Port LEDs, E3120 LEDs, LED Patterns 21
E3120 Power Source, Power Source, Power Connection 16
E3120 Power Supply, Power Supply Options 12
E3120 Specifications, Product Specifications, Physical Specifications, Environmental Specifications 22

F

FCC Notice, Federal Communications Commission, Regulatory Information 23

H

Hardware Installation 11

I

Industry Canada Notice 23

L

LEDs, LED Patterns, LED Indicator Patterns 9

O

Open Source Declaration 6

R

Redundant Power Supply, Power Supply Module, Installing a Power Supply, Redundant Power Supply Installation 13
Regulatory Information, Compliance Information, Regulatory & Compliance 23
Regulatory Information, Hazardous Substances 25
Regulatory Statement, BSMI Statement, EMC Statement, BSMI EMC Statement 24
Removing a Power Supply 14
Replacing a Power Supply, E3120 Power Supply, Replace a Power Supply 15

S

support, see technical support

T

technical support
contacting 5